

1A Low Dropout Positive Voltage Regulator

GENERAL DESCRIPTION

The XB1117 series is 1A Bi-polar transistor LDO voltage regulator. Output voltage of the XB1117P series is fixed to 1.8V, 2.5V, 3.3V, and 5.0V. The XB1117K series output voltage is adjustable by the external resistors. Please refer to the absolute maximum ratings for the difference between the rated input voltage of the XB1117P50 ($V_{OUT}=5.0V$) and XB1117P18, 25, 31, K12B. With the dropout voltage 1.2V (TYP.), output current can be generated up to 1A. The built-in overcurrent circuit and thermal protection circuit start to operate when either one of output put current reaches the current limit level or junction temperature reaches the temperature limit. The XB1117 series provide stable line and load regulation by using an input capacitor and an output capacitor (10 μ F, tantalum). Package is available in SOT-223.

APPLICATIONS

- Highly efficient linear regulators
- 5V ~ 3.3V DC / DC converter
- Battery charger
- Local power supply inside equipment
- Battery powered equipment

FEATURES

- | | |
|--------------------------|---|
| Maximum Output Current | : 1A |
| Output Voltages | : 1.8V, 2.5V, 3.3V, 5.0V, ADJ |
| Output Voltage Accuracy | : $\pm 1\%$ |
| Low Dropout Voltage | : 1.2V @ $I_{OUT}=1A$ |
| Line Regulation (TYP.) | : 0.04% (ADJ) |
| Load Regulation (TYP.) | : 0.1% (ADJ) |
| Adjust Pin Current | : Less than 120 μ A (ADJ) |
| Protection Circuit | : Over-current protection
Thermal protection |
| Package | : SOT-223 |
| Environmentally Friendly | : EU RoHS Compliant, Pb Free |

TYPICAL APPLICATION CIRCUIT

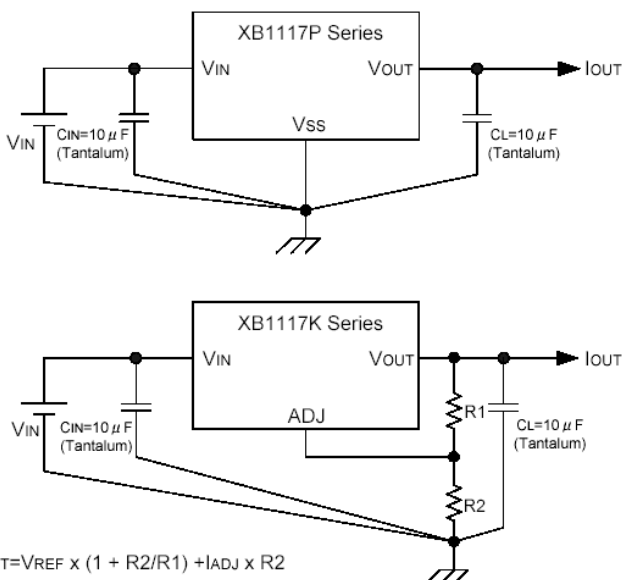

$$V_{OUT} = V_{REF} \times (1 + R2/R1) + I_{ADJ} \times R2$$

TYPICAL PERFORMANCE CHARACTERISTICS

Reference Voltage vs. Ambient Temperature

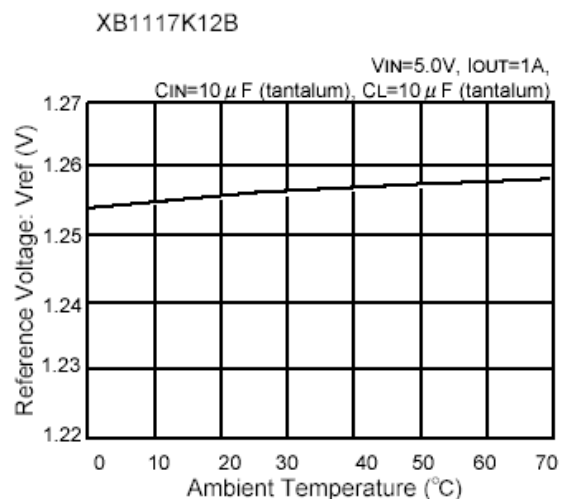

PIN CONFIGURATION

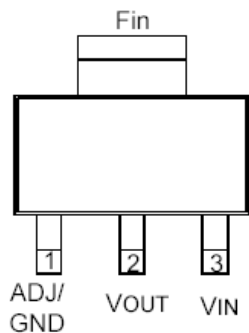

SOT-223
(TOP VIEW)

PIN ASSIGNMENT

PIN NUMBER	PIN NAME	FUNCTIONS
1	ADJ/GND	ADJ/Ground
2	VOUT	Output
3	VIN	Input

* The electrical potential of the package fin is the same as the VOUT pin.

PRODUCT CLASSIFICATION

Ordering Information

XB1117 - ^(*)

DESIGNATOR	DESCRIPTION	SYMBOL	DESCRIPTION
	Type of Regulators	P	Fixed VOUT type
		K	Adjustable VOUT type
	Output Voltage & Accuracy	181	Fixed VOUT 1.80V (± 1%)
		251	Fixed VOUT 2.50V (± 1%)
		331	Fixed VOUT 3.30V (± 1%)
		501	Fixed VOUT 5.00V (± 1%)
		12B	Adjustable VOUT 1.25V (± 1%)
-	Packages Taping Type ^(*)	FR-G	SOT-223

^(*) The "-G" suffix indicates that the products are Halogen and Antimony free as well as being fully RoHS compliant.

^(*) The device orientation is fixed in its embossed tape pocket. For reverse orientation, please contact your local Torex sales office or representative. (Standard orientation: R- , Reverse orientation: L-)

BLOCK DIAGRAM

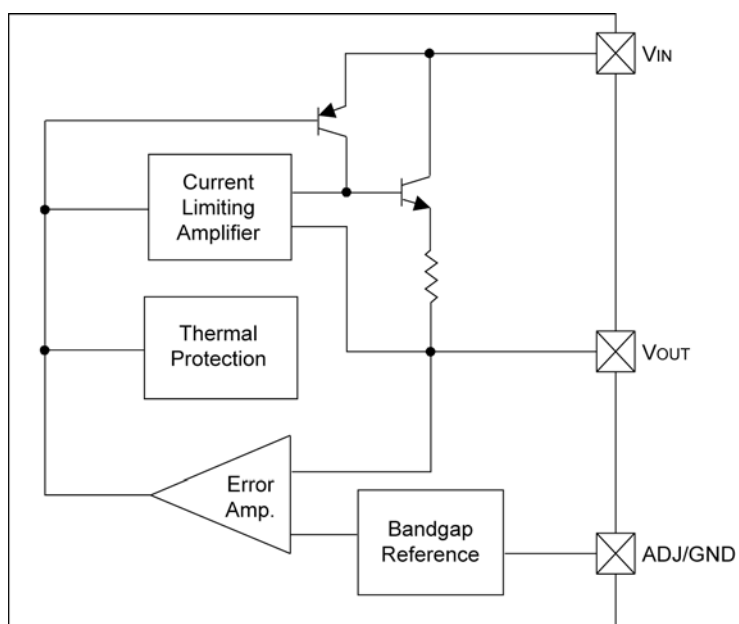

ABSOLUTE MAXIMUM RATINGS

XB1117P501

PARAMETER	SYMBOL	RATINGS	UNITS
Input Voltage	V _{IN}	10.0	V
Thermal Resistance (Junction to Case)	J _C	15	/W
Thermal Resistance (Junction to Ambient)	J _A	160	
Power Dissipation (T=100)	P _D	625	mW
Operating Temperature Range	T _{opr}	0 ~ + 70	
Operating Junction Temperature Range	T _j	0 ~ + 125	
Storage Temperature Range	T _{stg}	- 65 ~ + 150	
Lead Temperature	T _{lead}	260	

*Stress above the listed absolute maximum rating may cause permanent damage to the device.

** The rated values of the XB1117P18 / 25 / 30 (V_{OUT}=1.8V, 2.5V and 3.0V) and XB1117K type are different from that of the XB1117P50 (V_{OUT}=5.0V).

ELECTRICAL CHARACTERISTICS

XB1117P501

T_a=25

PARAMETER	SYMBOL	CONDITIONS	MIN.	TYP.	MAX.	UNITS	
Output Voltage	V _{OUT}	V _{IN} =7.0V I _{OUT} =0A	4.950	5.000	5.050	V	
		*Over Temp.	4.900	5.000	5.100		
Line Regulation	V _{OUT1}	7.0V V _{IN} 9.0V I _{OUT} =0A	*Over Temp.	-	1	6	mV
Load Regulation	V _{OUT2}	V _{IN} =7.0V 0A I _{OUT} 1.0A	*Over Temp.	-	5.0	15.2	
Dropout Voltage	V _{dif}	V _{OUT} = ± 1% 0A I _{OUT} 1.0A	-	1.2	1.4	V	
		*Over Temp.	-	1.3	-		
Current Limit	I _{LIM}	7.0V V _{IN} 10.0V	*Over Temp.	1.0	1.5	-	A
Supply Current	I _{SS}	V _{IN} =7.0V 0A I _{OUT} 1.0A	*Over Temp.	-	6	13	mA
Temperature Coefficient	T _C	7.0V V _{IN} 10.0V 0A I _{OUT} 1.0A	-	50	-	ppm/	
Temperature Stability	T _S	V _{IN} =7.0V I _{OUT} =100mA	*Over Temp.	-	0.5	-	%

*Over Temp. = Over Temperature (0 ~ + 70)

ABSOLUTE MAXIMUM RATINGS

XB1117P181, P251, P331, K12B

PARAMETER	SYMBOL	RATINGS	UNITS
Input Voltage	V _{IN}	7.0	V
Thermal Resistance (Junction to Case)	J _C	15	/W
Thermal Resistance (Junction to Ambient)	J _A	160	
Power Dissipation (T=100)	P _D	625	mW
Operating Temperature Range	T _{OPR}	0 ~ 70	
Operating Temperature Range	T _J	0 ~ 125	
Storage Temperature Range	T _{STG}	-65 ~ 150	
Lead Temperature	T _{LEAD}	260	

*Stress above the listed absolute maximum rating may cause permanent damage to the device.

ELECTRICAL CHARACTERISTICS

XB1117P181

 T_J=25

PARAMETER	SYMBOL	CONDITIONS	MIN.	TYP.	MAX.	UNITS
Output Voltage	V _{OUT}	V _{IN} =5.0V I _{OUT} =0A *Over Temp.	1.782	1.800	1.818	V
Line Regulation	V _{OUT1}	4.75V V _{IN} 7.0V I _{OUT} = 0A	-	1.0	5.5	mV
Load Regulation	V _{OUT2}	V _{IN} =5.0V 0A I _{OUT} 1.0A *Over Temp.	-	1.80 3.70	18.2 22.0	mV
Dropout Voltage	V _{dif}	V _{OUT} = ± 1% 0A I _{OUT} 1.0A *Over Temp.	-	1.2 1.3	1.4 -	V
Current Limit	I _{LIM}	4.75V V _{IN} 7.0V *Over Temp.	1.0	1.5	-	A
Supply Current	I _{SS}	V _{IN} =5.0V 0A I _{OUT} 1.0A *Over Temp.	-	6	13	mA
Temperature Coefficient	T _C	4.75V V _{IN} 7.0V 0A I _{OUT} 1.0A	-	50	-	ppm/
Temperature Stability	T _S	V _{IN} =5.0V I _{OUT} =100mA *Over Temp.	-	0.5	-	%

*Over Temp. = Over Temperature (0 ~ + 70)

XB1117P251

 T_J=25

PARAMETER	SYMBOL	CONDITIONS	STANDARD VALUE			UNITS
			MIN.	TYP.	MAX.	
Output Voltage	V _{OUT}	V _{IN} =5.0V I _{OUT} =0A *Over Temp.	2.475 2.450	2.500	2.525 2.550	V
Line Regulation	V _{OUT1}	4.75V V _{IN} 7.0V I _{OUT} =0A	-	1.0	6.8	mV
Load Regulation	V _{OUT2}	V _{IN} =5.0V 0A I _{OUT} 1.0A *Over Temp.	-	2.5 5.1	25.3 30.3	mV
Dropout Voltage	V _{dif}	V _{OUT} = ± 1% 0A I _{OUT} 1.0A *Over Temp.	-	1.2 1.3	1.4 -	V
Current Limit	I _{LIM}	4.75V V _{IN} 7.0V *Over Temp.	1.0	1.5	-	A
Supply Current	I _{SS}	V _{IN} =5.0V 0A I _{OUT} 1.0A *Over Temp.	-	6	13	mA
Temperature Coefficient	T _C	4.75V V _{IN} 7.0V 0A I _{OUT} 1.0A	-	50	-	ppm/
Temperature Stability	T _S	V _{IN} =5.0V I _{OUT} =100mA *Over Temp.	-	0.5	-	%

*Over Temp. = Over Temperature (0 ~ + 70)

ELECTRICAL CHARACTERISTICS (Continued)

XB1117P331

T_J=25

PARAMETER	SYMBOL	CONDITIONS	MIN.	TYP.	MAX.	UNITS
Output Voltage	V _{OUT}	V _{IN} =5.0V I _{OUT} =0A	3.267	3.300	3.333	V
		*Over Temp.	3.234	3.300	3.366	
Line Regulation	V _{OUT1}	4.75V V _{IN} 7.0V I _{OUT} =0A	-	1.0	4.5	mV
Load Regulation	V _{OUT2}	V _{IN} =5.0V 0A I _{OUT} 1.0V	-	3.4	10.0	
Dropout Voltage	V _{dif}	V _{OUT} = ± 1% 0A I _{OUT} 1.0A	-	1.2	1.4	V
		*Over Temp.	-	1.3	-	
Current Limit	I _{LIM}	4.75V V _{IN} 7.0V	1.0	1.5	-	A
Supply Current	I _{SS}	V _{IN} =5.0V 0A I _{OUT} 1.0A	-	6	13	mA
Temperature Coefficient	T _C	4.75V V _{IN} 7.0V 0A I _{OUT} 1.0A	-	50	-	ppm/
Temperature Stability	T _S	V _{IN} =5.0V I _{OUT} =100mA	-	0.5	-	%

*Over Temp. = Over Temperature (0 ~ +70 °C)

XB1117K12B

T_J=25

PARAMETER	SYMBOL	CONDITIONS	MIN.	TYP.	MAX.	UNITS
Reference voltage	V _{ref}	V _{IN} =5.0V I _{OUT} =10mA	1.238	1.250	1.262	V
		*Over Temp.	1.225	1.250	1.275	
Line Regulation	V _{OUT1}	4.75V V _{IN} 7.0V I _{OUT} =0A	-	0.04	0.20	%
Load Regulation	V _{OUT2}	V _{IN} =5.0V 10mA I _{OUT} 1.0A	-	0.1	0.3	%
		*Over Temp.	-	0.2	0.4	
Dropout Voltage	V _{dif}	V _{OUT} = ± 1% 10mA I _{OUT} 1.0A	-	1.2	1.4	V
		*Over Temp.	-	1.3	-	
Current Limit	I _{LIM}	2.75A V _{IN} 7.0V	1.0	1.5	-	A
Temperature Coefficient	T _C	2.75V V _{IN} 7.0V 10mA I _{OUT} 1.0A	-	50	-	ppm/
Adjust Pin Current	I _{ADJ}	2.75V V _{IN} 7.0V 10mA I _{OUT} 1.0A	-	55	-	μA
		*Over Temp.	-	-	120	
Adjust Pin Current Change	I _{ADJ}	2.75V V _{IN} 7.0V 10mA I _{OUT} 1.0A	-	0.2	5.0	μA
Temperature Stability	T _S	V _{IN} =5.0V I _{OUT} =100mA	-	0.5	-	%
Minimum Load Current	I _{OUT}	V _{OUT} =5.0V	-	-	10	mA

*Over Temp. = Over Temperature (0 ~ +70 °C)

OPERATIONAL EXPLANATION

1. Output voltage adjustment

The XB1117 series provide a stable output by comparing the output voltage to an internal reference voltage. With the adjustable XB1117K type, a 1.25V reference voltage (V_{REF}) is fixed between the V_{OUT} pin and the ADJ pin and the external resistors R1 and R2 are used to set the output voltage. The resistance values of R1 and R2 should be set so as to provide a minimum load current of 10mA. The output voltage is given by the following equation.

$$V_{OUT} = V_{REF}(1 + R2/R1) + I_{ADJ} \times R2$$

The output voltage of the XB1117P type is internally fixed to 1.8V, 2.5V, 3.3V, and 5.0V so external resistors are not necessary.

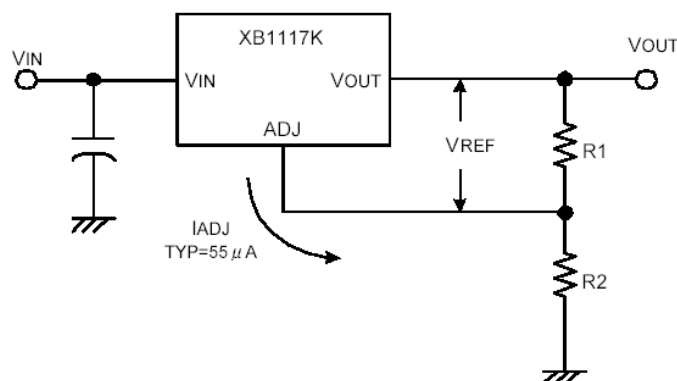

2. Stability and load regulation

The XB1117 series requires a load capacitor between the V_{OUT} pin and the GND pin to provide phase compensation thereby ensuring stability of the output voltage. Either a tantalum capacitor of more than 10 μ F (TYP.) or an aluminum electrolytic capacitor of more than 50 μ F (TYP.) should be connected.

(Note : The capacitor's ESR value should not exceed 0.5 .)

The output capacitor does not have a theoretical upper limit so increasing its value will increase stability. $C_L = 100 \mu$ F or more is typical for high current regulator design.

In order to avoid any reductions in output voltage accuracy with the XB1117K type, we recommend not to place a parasitic resistor (R_p) between the V_{OUT} pin and the divider resistor R1. The parasitic resistor (R_p) does not influence the output however if the divider resistor R1 is directly connected to the V_{OUT} pin.

With the XB1117P type, although external resistor (R1) is internally connected to the V_{OUT} pin, stability can be maintained by not wiring a parasitic resistor to the GND pin.

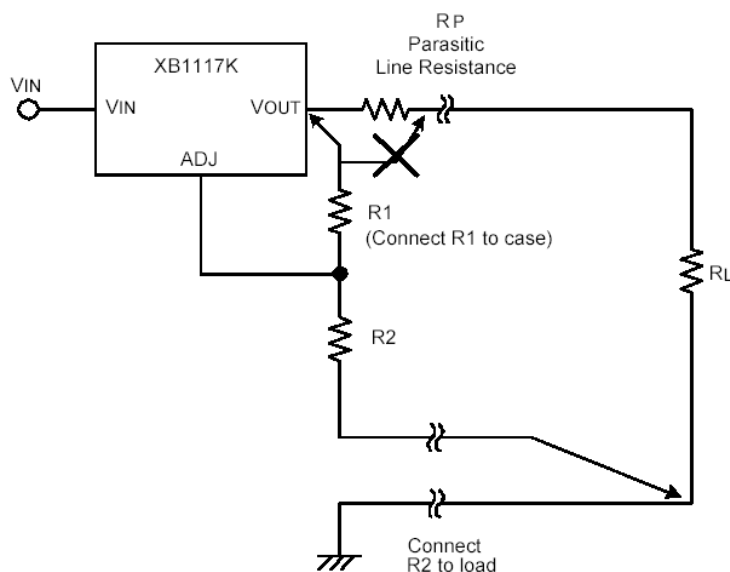

OPERATIONAL EXPLANATION (Continued)

3. Thermal protection

XB1117 series has thermal protection which limits junction temperature to 150 °C. However, device functionally is only guaranteed to a maximum junction temperature of + 125 °C. The power dissipation and junction temperature for the XB1117 series are given by;

$$P_D = (V_{IN} - V_{OUT}) \times I_{OUT}$$

$$T_J = T_A + (P_D \times \theta_{JA})$$

NOTE : T_J must not exceed 125 °C.

4. Current limit protection

XB1117 series is protected against overload conditions. Current protection is triggered at 1.5A (TYP.).

5. Thermal consideration

The XB1117 series contain thermal limiting circuitry designed to protect itself from over-temperature conditions. Even for normal load conditions, maximum junction temperature ratings must not be exceeded. As mentioned in thermal protection section, we need to consider all sources of thermal resistance between junction and ambient. It includes junction-to-case, case-to-heat-sink interface and heat sink thermal resistance itself.

Junction-to-case thermal resistance is specified from the IC junction to the bottom of the case directly below the die. Proper mounting is required to ensure the best possible thermal flow from this area of the package to the heat sink. The case of all devices in this product series is electrically connected to the output. Therefore, if the case of the device is not electrically isolated, a thermally conductive spacer is recommended.

APPLICATION CIRCUITS

Adjustable Output Voltage

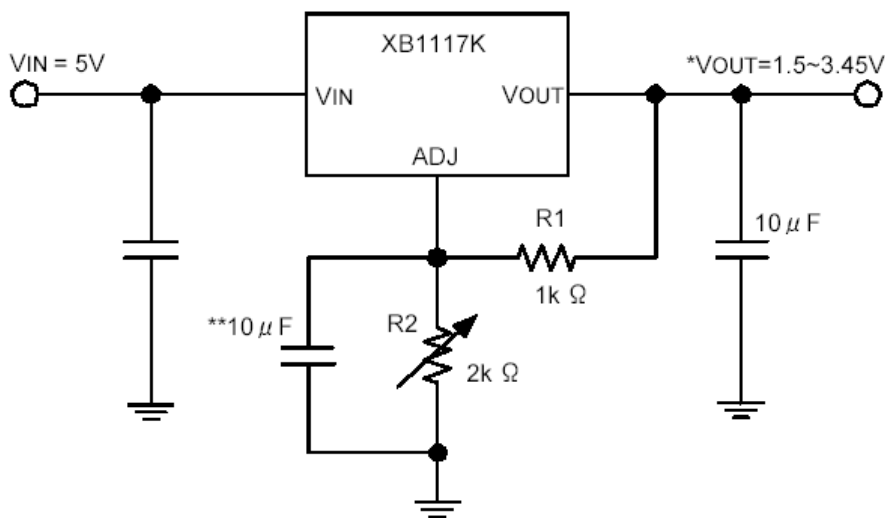

$$\text{NOTE: } *V_{OUT} = V_{REF} \left(1 + \frac{R_2}{R_1} \right) + I_{ADJ} \times R_2$$

** Optional for improved ripple rejection.

APPLICATION CIRCUITS (Continued)

Regulator with reference voltage

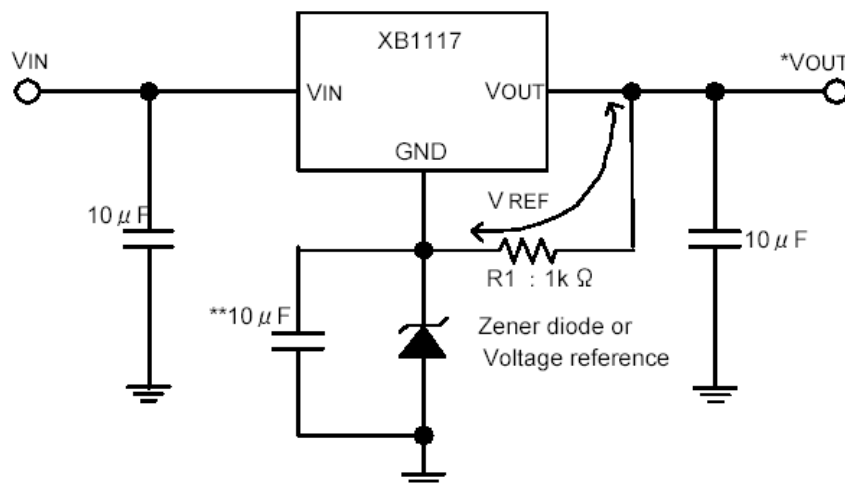

NOTE: $*V_{OUT} = V_{REF} + V_Z$ (V_Z : Zener diode)

** Optional for improved ripple rejection.

Regulator with reverse diode protection

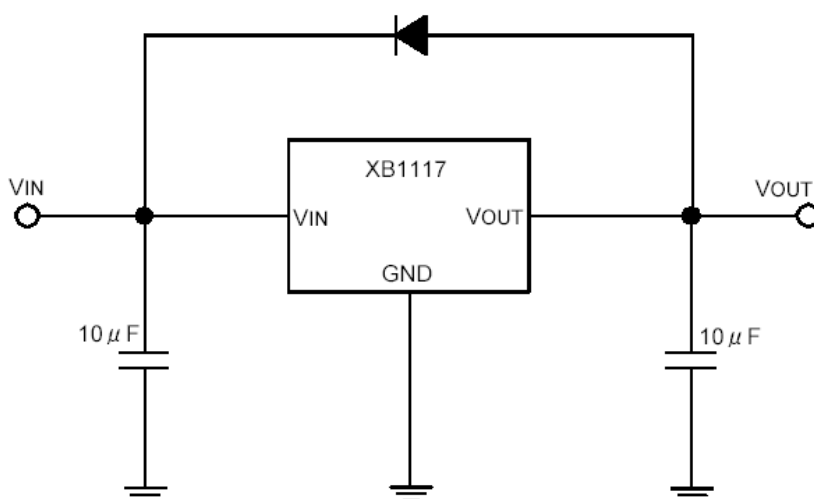

TYPICAL PERFORMANCE CHARACTERISTICS

(1) Load Regulation vs. Ambient Temperature

XB1117K12B

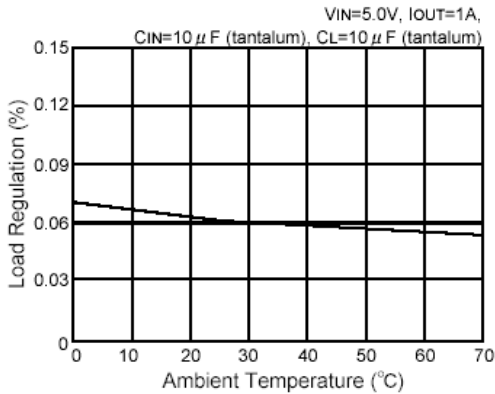

(2) Reference Voltage vs. Ambient Temperature

XB1117K12B

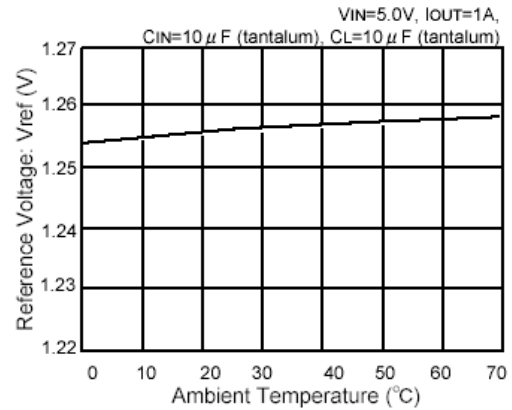

(3) Output Short Circuit Current vs. Dropout Voltage

XB1117P331

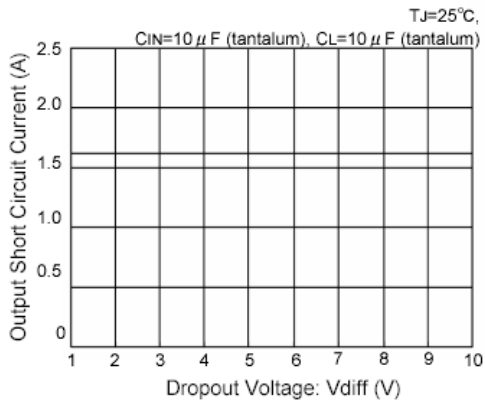

(4) Dropout Voltage vs. Output Current

XB1117P331

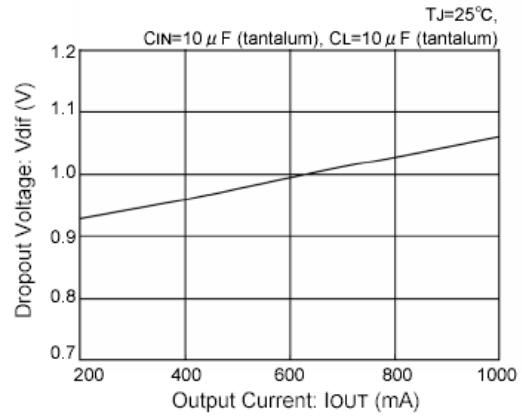

(5) Adjust Pin Current vs. Ambient Temperature

XB1117K12B

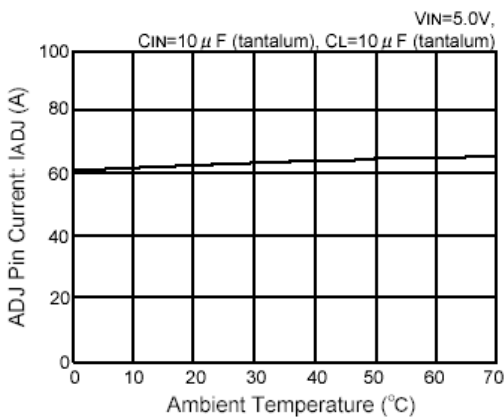

(6) Supply Current vs. Dropout Voltage

XB1117P331

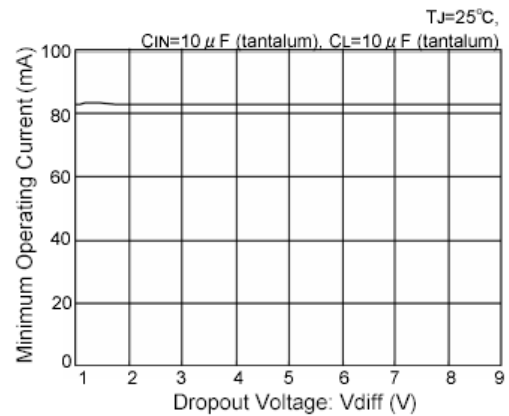

(7) Load Transient Response

XB1117P331

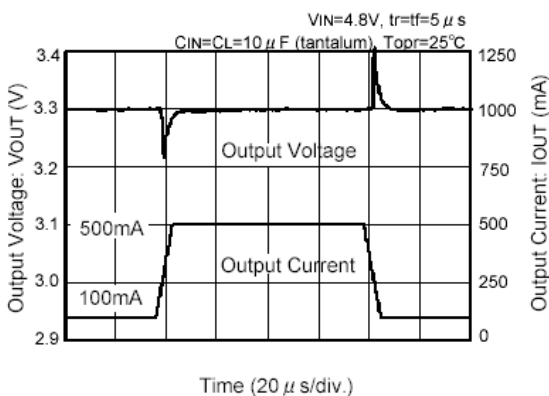

(8) Line Transient Response

XB1117P331

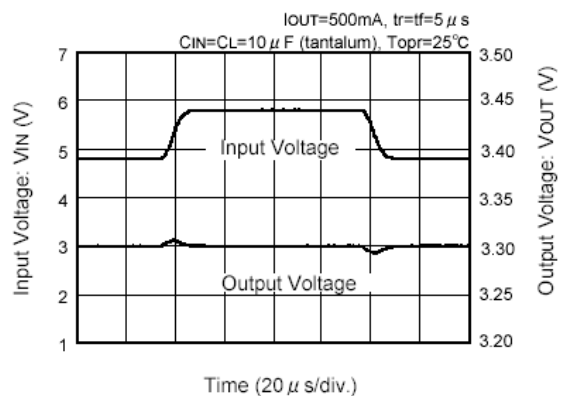

PACKAGING INFORMATION

SOT-223

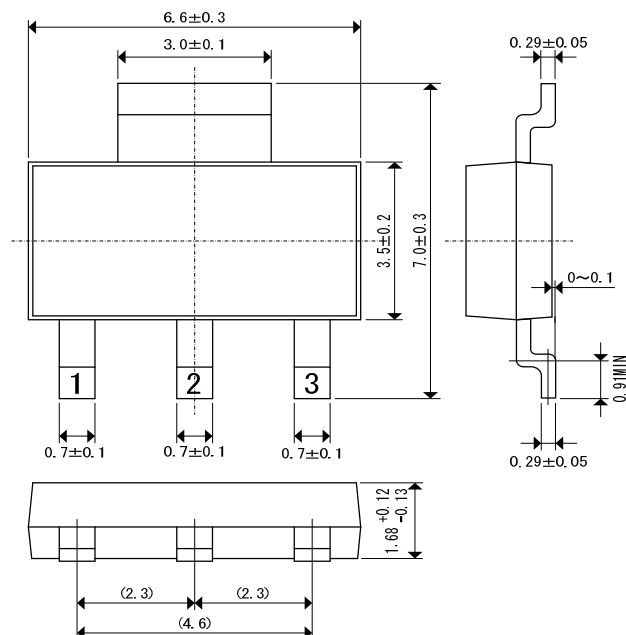

MARKING RULE

SOT-223

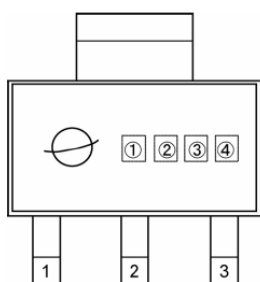

SOT-223
(TOP VIEW)

Represents product series

MARK	PRODUCT SERIES
B	XB1117xxxxFx

Represents fixed or adjustable output voltage

MARK	PRODUCT SERIES
K	XB1117KxxxxFx
P	XB1117PxxxxFx

Represents output voltage

MARK	OUTPUT VOLTAGE (V)	PRODUCT SERIES
B	ADJ	XB1117K12BFx
K	1.8	XB1117P181Fx
T	2.5	XB1117P251Fx
2	3.3	XB1117P331Fx
M	5.0	XB1117P501Fx

Represents production lot number

0 to 9, A to Z repeated. (G, I, J, O, Q, W are excepted.)

1. The products and product specifications contained herein are subject to change without notice to improve performance characteristics. Consult us, or our representatives before use, to confirm that the information in this datasheet is up to date.
2. We assume no responsibility for any infringement of patents, patent rights, or other rights arising from the use of any information and circuitry in this datasheet.
3. Please ensure suitable shipping controls (including fail-safe designs and aging protection) are in force for equipment employing products listed in this datasheet.
4. The products in this datasheet are not developed, designed, or approved for use with such equipment whose failure or malfunction can be reasonably expected to directly endanger the life of, or cause significant injury to, the user.
(e.g. Atomic energy; aerospace; transport; combustion and associated safety equipment thereof.)
5. Please use the products listed in this datasheet within the specified ranges.
Should you wish to use the products under conditions exceeding the specifications, please consult us or our representatives.
6. We assume no responsibility for damage or loss due to abnormal use.
7. All rights reserved. No part of this datasheet may be copied or reproduced without the prior permission of TOREX SEMICONDUCTOR LTD.

TOREX SEMICONDUCTOR LTD.