

www.DataSheet4U.com

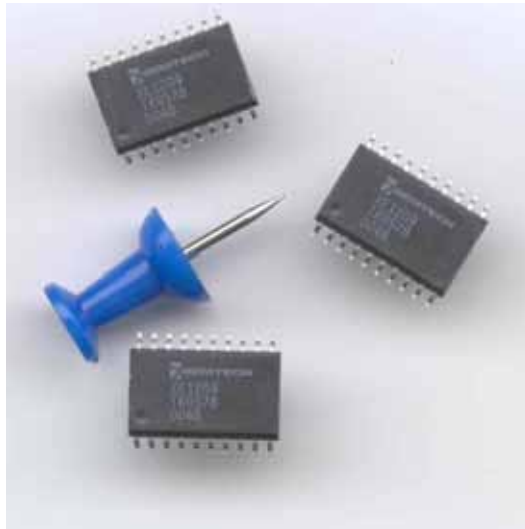

# **XE1209**

---

## **30 – 70 kHz Ultra Low Power CMOS Transceiver**

---

### **GENERAL DESCRIPTION**

The XE1209 is a CMOS Ultra Low-Power transceiver for short-range low frequency RF data communications system. It uses 2-level Continuous Phase FSK modulation. The receiver section includes the preamplifier, the down-converter, and the channel filters, the demodulator and the bit synchronizer, which delivers synchronized data at the output. The transmitter section is composed of a Direct Digital Synthesizer (DDS), and the power amplifier generating a square-wave output current. The XE1209 has carrier detector to detect the presence of a signal at the carrier frequency. The local clock is based on a 32kHz crystal oscillator and a PLL to generate the required Local oscillator (LO) frequency. The XE1209 has a simple interface with an external microcontroller.

### **KEY FEATURES**

- Single chip transceiver
- Low cost
- Low external component count
- Ultra Low Power
  - Stand-by mode
  - Carrier detection mode
  - Low-power receiver mode
- Unlicensed frequency band
- Short range applications; 1 to 3 meters

### **APPLICATIONS**

- Remote control
- Short Range Wireless data
- Access control

### **ORDERING INFORMATION**

Part number	Temperature range	Package
XE1209C012TRLF	-10°C to +60°	SO-20 RoHS compliant

## 1 PIN DESCRIPTION

Pin #	Name	Description
1	TEST	Test pin
2	VSS	Ground for digital
3	QIN	Xtal pin or input for external clock
4	VDDA	Supply voltage for analog
5	QOUT	Xtal pin
6	VSSA	Ground for analog
7	IREF	Iref node for external resistance
8	VREF	Vref node for external capacitance
9	SUPTTEST	Test pin
10	RE	Receiver enable
11	INA	RF input signal
12	INB	RF input signal
13	VSSPA	Ground for RF power amplifier
14	PAOUT	RF power amplifier output
15	VDD	Supply voltage for digital
16	DCLK	Received data clock output
17	DATA	Input/output bit stream or output of the carrier detector
18	DE	Data enable for 3-wire communication
19	SD	Data input for 3-wire communication
20	SC	Clock input for 3-wire communication

## 2 TYPICAL APPLICATION

The product is to be used in a system for low frequency RF data communications. The transmission is made with 2-level CPFSK modulation. The modulated signal has a carrier frequency  $f_c$  and a deviation frequency  $\Delta f$ ; the coding of the data is the following:

$$f_{RFIn} = f_c + \Delta f \equiv "1" \qquad f_{RFIn} = f_c - \Delta f \equiv "0".$$

above shows the structure of the transceiver and the external components required by the application. A 3-wire bus allows the product to receive configuration data from a microcontroller. Note: pin TEST remains *unconnected*.

### 2.1 TYPICAL EXTERNAL COMPONENTS

Besides the components needed for the RF communication itself, the following external components are required:

Name	Type	Pins to be connected	Value	Tolerance	Max. Temp. variation
Cvdd	Capacitor	VDD - VSS	100 nF	± 10 %	± 5 % over -10 °C to 60 °C
Cvref	Capacitor	VREF - VSS	47 nF	± 10 %	± 5 % over -10 °C to 60 °C
Riref	Resistance	IREF - VSS	280 kΩ	± 1 %	± 100 ppm/K
Xtal	Crystal	QIN - QOUT	32.768 kHz	± 20 ppm	- 50 ppm over -10 to 60 °C

The reference of the crystal used for Xtal is the following:  
"DS26 watch crystal" from Micro Crystal Switzerland

## 3 GENERAL FUNCTIONAL DESCRIPTION

The XE1209 is composed of 6 main functional blocks:

### Receiver

The receiver channel converts a 2-level CPFSK modulated signal into a bit stream. It is composed of the following blocks: preamplifier, down-converters (0-IF architecture), channel filters, limiters, demodulator, and bit synchronizer.

[www.DataSheet4U.com](http://www.DataSheet4U.com)

#### Transmitter

The transmitter performs the modulation of an input bit-stream. The main parts of this block are a DDS (Direct Digital Synthesizer), generating a digital signal with a modulated period, and a power amplifier generating a square-wave output current controlled by the output of the DDS.

#### Carrier detector

The function of this block is to detect the presence of a signal at the carrier frequency  $f_c$ .

#### Clock generator

The clock generator is composed of a quartz oscillator generating the reference signal at 32.768 kHz, and a PLL (Phase Locked Loop), whose function is to deliver a signal at a frequency which is a multiple of the oscillator output; the multiplying factor is programmable on two values.

#### Service block

This block provides the whole circuit with the required voltage references and current sources.

#### Digital part

The digital part has two main functions:

- implement the 3-wire interface for the communication with the external microcontroller.
- generate all the internal signals according to the selected mode of operation and the content of the configuration register

The product has four operating modes:

- a standby mode (M1), where all the blocks are powered off (in this mode, the oscillator can be either on or off according to the value of a bit (called OSC) stored in the configuration register),
- a carrier detector mode (M2), where only the carrier detector is active,
- a transmitter mode (M3), where the transmitter is powered on,
- A receiver mode (M4), where the receiver is powered on.

www.DataSheet4U.com

The RE input and the bit TR in the configuration register determine the mode setting. The Table 1 gives the status of the main blocks in each mode.

		M1 standby	M2 carrier detection	M3 Tx	M4 Rx
Receiver		off	off	off	ON
Transmitter		off	off	ON	off
Carrier detector		off	ON	off	off
Clock generator	Osc	ON/off	ON / off	ON / off	ON / off
	PLL	off	off	ON	ON
Service block		off	ON	ON	ON
Digital part		ON	ON	ON	ON

Table 1 Mode selection

When the oscillator is off (bit OSC=0), an external clock is applied on the pin QIN.

#### 4 ABSOLUTE MAXIMUM RATINGS, OPERATING RANGES AND EXTERNAL CONDITIONS

Symb	Parameters	Conditions	Min	Typ	Max	Unit
STO_TR	Storage temperature range		-40	-	+85	°C
TR	Operating temperature range		-10	+25	+60	°C
VDD	Operating supply voltage		2.0	2.6	3.2	V
FREF_EXT	PLL reference frequency	External oscillator, VDD=2.6 V, temp=25 °C	32.735	32.768	32.800	kHz
CL_CK	External capacitance load on the pin CLK	Full range of supply and temperature	-	-	5	pF
IL_CK	External leakage current on the pin CLK	Full range of supply and temperature	-	-	50	nA
RP_OSC	Parasitic resistance between the pins QIN, QOUT and any other ASIC pin	Full range of supply and temperature	20	-	-	MΩ
CP_OSC	Parasitic capacitance between the pins QIN, QOUT and any other ASIC pin	Full range of supply and temperature	-	-	0.5	pF

Stresses above those listed in this clause may cause permanent device failure. Exposure to absolute maximum ratings for extended periods may affect device reliability.

Electrostatic discharges:

- The device withstands 2000 Volts Standardized Human Body Model ESD pulses when tested according to MIL883C method 3015.5 (pin combination 2).

Latch-up:

- Static latch-up protection level is 30mA at 25 C

[www.DataSheet4U.com](http://www.DataSheet4U.com)

## 5 ELECTRICAL SPECIFICATIONS

Electrical specifications are defined for VDD=2.6 V, Temp=25 °C, fc=36.86 kHz, and a data rate of 1820 bit/s, unless otherwise specified.

Symb	Parameters	Conditions	Min	Typ	Max	Unit
IDDS1	Standby current	Oscillator stopped	-	0.15	1	μA
IDDS2	Standby current	Oscillator active, VDD=3V, Temp= -10 to +60°C, unloaded	-	1	2	μA
IDD1	Supply current in carrier detection mode (M2)	Temp = -10 to +60 °C	-	95	120	μA
IDD2	Supply current in receiver mode (M4)	Temp = -10 to +60 °C	-	200	300	μA
ISINK	Sink current transmitter mode (peak value)	Load = resistance of 15 ohms connected between VDD and pin PAOUT, programmable through the 3-wire bus	82	110	138	mA
			45	60	75	mA
			23	30	37	mA
			5.65	7.5	9.35	mA
			2.60	3.5	4.40	mA
			1.35	1.80	2.25	mA
FREF	PLL reference frequency		-	32.768	-	kHz
FR	PLL frequency	Programmable via 3-wire bus	588.65	589.82	591.00	kHz
			719.45	720.90	722.35	kHz
RIN	RF differential input DC resistance		500	1000	-	kΩ
CIN	RF differential input capacitance		-	25	-	pF
RFS	RF sensitivity	Rsource=100Ω BER=10 <sup>-4</sup>	200	70	-	μVp
MAXIN	Maximum RF effective input signal	Without any parasitic signal	-	-	15	mV
FC	Transmission carrier frequency		-	36.86	-	kHz
			-	45.05	-	kHz
ATT	Adjacent channel rejection at f = 30.6 kHz	At RFSmin Rsource=100Ω, BER=10 <sup>-4</sup>	11	23	-	dBc
ATT3	Adjacent channel rejection at f = 110.58 kHz	At RFSmin Rsource=100Ω, BER=10 <sup>-4</sup>	-1	3	-	dBc
CMRR DC	DC Common mode rejection ratio	At RFSmin Rsource=100Ω, BER=10 <sup>-4</sup>	30	-	-	dB
BW	Receiver -3dB Bandwidth	FC=36.86 kHz, DSB	-	5000	-	Hz
DR	Data rate		-	1820	-	bit/s
FDEV	Frequency deviation	FC=36.86 kHz	-	1872	-	Hz
PDL	Carrier detector level	3 rising edges measured at output in a 900us time window	140	200	260	μVp
			400	500	600	μVp

Symb	Parameters	Conditions	Min	Typ	Max	Unit
RAC	Receiver Activation time	from carrier-detector mode and with oscillator running	-	1.6	2.5	ms
XOAC	Xtal oscillator activation time	at temp =-10 to +60°C		0.2	2	s
LL	Logical low level		VSS	-	0.2*VDD	V
HL	Logical high level		0.8*VDD	-	VDD	V

## 6 INPUT/OUTPUT RF SIGNALS

### 6.1 TRANSMIT MODE

The transmitter is composed of a DDS and a power amplifier. The DDS is a 12-bits counter, which is incremented by 256+13 when the input data is 1 and by 256-13 when the input data is 0. This way, the frequency deviation is equal to:

$$\Delta f = \frac{13 \cdot N \cdot FREF}{2^{12}},$$

Where N is the multiplying factor of the PLL, and FREF the frequency of the reference clock. With N=18 and FREF=32.768 kHz, the expression gives  $\Delta f=1872$  Hz.

The power amplifier delivers a square wave current whose amplitude is programmable (see the configuration register section below). The figure below shows the shapes of the signals when, as an example, ISINK=110 mA. The transmitter processes the input data in real time without any additional sampling or filtering, which means that the data rate does not depend on the XE1209.

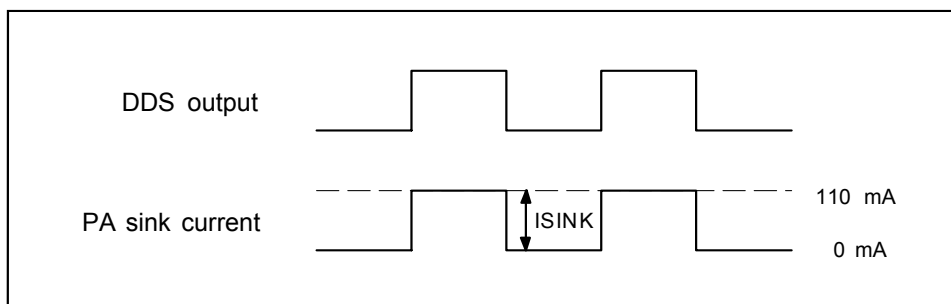

**6.2 RECEIVE MODE**

The data available at receiver output are valid between 20% and 60% of the data period (1/DR) after the rising edge of the clock (DCLK) as shown in figure below. The received data rate must be 1820 bit/s +/- 2 % for proper bit synchronizer operation. In addition, the bit synchronizer needs to see at least one transition (from “1” to “0” or from “0” to “1”) every 8 bits present at its input.

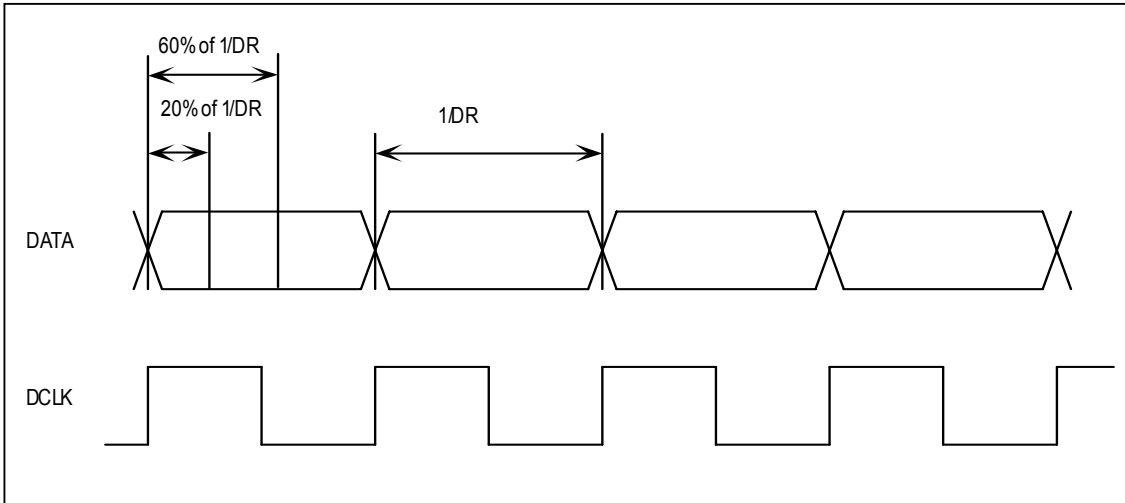

At the beginning of the reception, the bit synchronizer needs to receive a preamble which is a sequence of 16 “0” and “1” bit sent alternatively.

**6.3 CARRIER DETECTION MODE**

The Carrier Detection mode is active when the TR bit in the configuration register is 0 and the RE input pin is 1. The signal present at RF inputs is amplified and compared to a voltage threshold. When a RF signal is present at the input, the comparator output is a square wave at a frequency equal to the frequency of the RF signal. This signal is fed into a 3-bit counter, whose output is directly available on the DATA pin. In this case, the DATA signal is a square wave whose frequency is 1/8 of the RF carrier frequency.

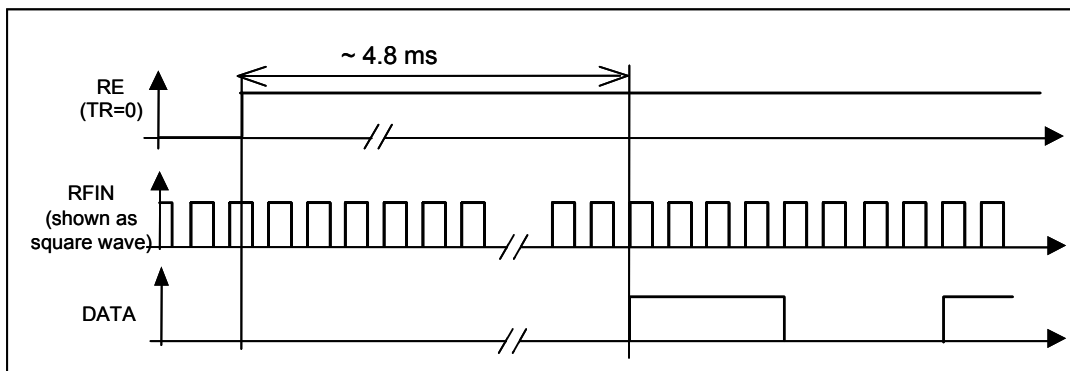

The carrier detector set-up time (after TR bit set to 0 and RE input set to 1) is 4.85ms when the carrier frequency is 36.86 kHz. In the applications where the carrier detector is turned on for a relative long period (tens to hundreds of ms), it is recommended to reset the block with a short transition to stand-by mode (RE=0). The timing diagram of the carrier detection is shown below when a RF signal is present at input and the function is programmed.

**7 PROGRAMMING / DATA INTERFACE**

Programming the XE1209 is performed through the 3-wire interface SC, SD, DE, as shown below. The enable signal DE goes low at the same time as the 8th falling edge of SC (that is, with a maximum delay between each other of 100 ns). From the rising edge of DE, the XE1209 will sample the data present on SD at the first 8 falling edges of SC, whatever is the following sequence on SC and SD. For a proper data transfer, the data on SD must be stable for 5 microseconds before and after each falling edge on SC.

The values on SC, SD and DE (as well as RE) must be kept constant (either at VDD or VSS) during all the time where the XE1209 has to be effective in modes M2, M3 and M4.

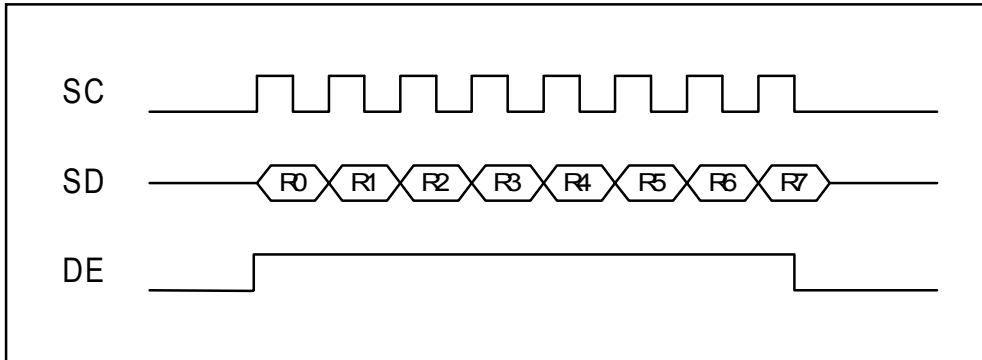

**7.1 CONFIGURATION REGISTER**

The content of the configuration register is described below. The bit R0 is the first received data during the 3-wire communication.

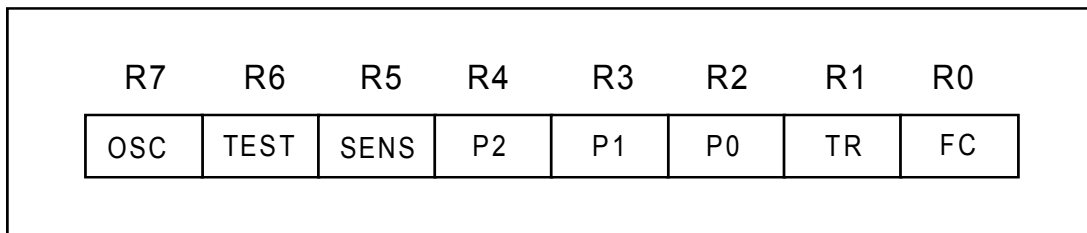



www.DataSheet4U.com

Name	Description	Convention	
		0	1
FC	Carrier frequency	36.86 kHz	45.05 kHz
TR	Transmission flag	Mode M1 (RE=0) Mode M2 (RE=1)	Mode M3 (RE=0) Mode M4 (RE=1)
P0	Power level	LSB (see Table 3) MSB	
P1	Power level		
P2	Power level		
SENS	Carrier detector threshold	200 $\mu$ V	500 $\mu$ V
TEST	Test flag	Normal mode	Test mode
OSC	Oscillator flag	External oscillator	Internal oscillator

Table 2 Configuration register

Correspondence between the word {P2 P1 P0} and the current sinked by the power amplifier is shown below. The words 110 and 111 are reserved for test purposes.

P2 P1 P0	Power amplifier current
0 0 0	1.8 mA
0 0 1	3.5 mA
0 1 0	7.5 mA
0 1 1	30 mA
1 0 0	60 mA
1 0 1	110 mA

Table 3 Sink current levels

TR (register)	RE (input pin)	Mode
0	0	M1 (standby)
0	1	M2 (carrier detector)
1	0	M3 (transmitter)
1	1	M4 (receiver)

Table 4 Mode selection

Upon start-up, a reset of the XE1209 is required to set the configuration register in a proper default mode. This is done by sending the binary word 'b00000000 to the circuit using the 3-wire bus, while setting RE to "0".

© Semtech 2005

All rights reserved. Reproduction in whole or in part is prohibited without the prior written consent of the copyright owner. The information presented in this document does not form part of any quotation or contract, is believed to be accurate and reliable and may be changed without notice. No liability will be accepted by the publisher for any consequence of its use. Publication thereof does not convey nor imply any license under patent or other industrial or intellectual property rights. Semtech. assumes no responsibility or liability whatsoever for any failure or unexpected operation resulting from misuse, neglect improper installation, repair or improper handling or unusual physical or electrical stress including, but not limited to, exposure to parameters beyond the specified maximum ratings or operation outside the specified range.

SEMTECH PRODUCTS ARE NOT DESIGNED, INTENDED, AUTHORIZED OR WARRANTED TO BE SUITABLE FOR USE IN LIFE-SUPPORT APPLICATIONS, DEVICES OR SYSTEMS OR OTHER CRITICAL APPLICATIONS. INCLUSION OF SEMTECH PRODUCTS IN SUCH APPLICATIONS IS UNDERSTOOD TO BE UNDERTAKEN SOLELY AT THE CUSTOMER'S OWN RISK. Should a customer purchase or use Semtech products for any such unauthorized application, the customer shall indemnify and hold Semtech and its officers, employees, subsidiaries, affiliates, and distributors harmless against all claims, costs damages and attorney fees which could arise.

#### Contact Information

Semtech Corporation  
Wireless and Sensing Products Division  
200 Flynn Road, Camarillo, CA 93012  
Phone (805) 498-2111 Fax : (805) 498-3804