

**Low Cost Serial-to-Ethernet Bridge for Embedded Applications**

**Description**

The Xecom XE232NET Serial-to-Ethernet Bridge modules provide a simple solution for connecting micro-controller based embedded systems to a Local Area Network. These modules include all of the hardware and software needed to link the serial port on the micro-controller to the local area network.

The XE232NET Serial-to-Ethernet bridge operates much the same as any Xecom serial modem. AT commands are used for control and configuration of The XE232NET. The XE232NET also utilizes the same pin configuration as the Xecom XE5690SM modem family. This permits one design to support either Ethernet or dial-up modem connectivity with a simple module swap.

Xecom offers two versions of the XE232NET. The XE232NET-1 with the Ethernet isolation transformer and the XE232NET-2 without the isolation transformer. An Evaluation Kit is available, model number XE232NET-K

**Features**

- Miniature Dual-In-line Package: 2.1” x 1.0”
- TTL compatible serial interface;
- Operates from a single +3.3 volt power supply
- Includes 10 Base-T Ethernet MAC and PHY
- Embedded protocols include, Ethernet, TCP, IP, UDP, ICMP, DHCP, ARP, HTTP, POP3, and SMTP
- Command and control with Serial AT Commands
- IEEE 10BASE-T compatible

**Models**

- XE232NET-1: Serial-to-Ethernet Bridge module with Ethernet isolation transformer included
- XE232NET-2: Serial-to-Ethernet Bridge module without isolation transformer.
- XE232NET-K: Ethernet Evaluation Kit includes XE232NET-1; evaluation board, required cables, and power supply
- XE232NET-1ITR: XE232NET-1 with an operating range of -40C to +85C
- XE232NET-2ITR: XE232NET-2 with an operating range of -40C to +85C

**XE232NET Block Diagram**

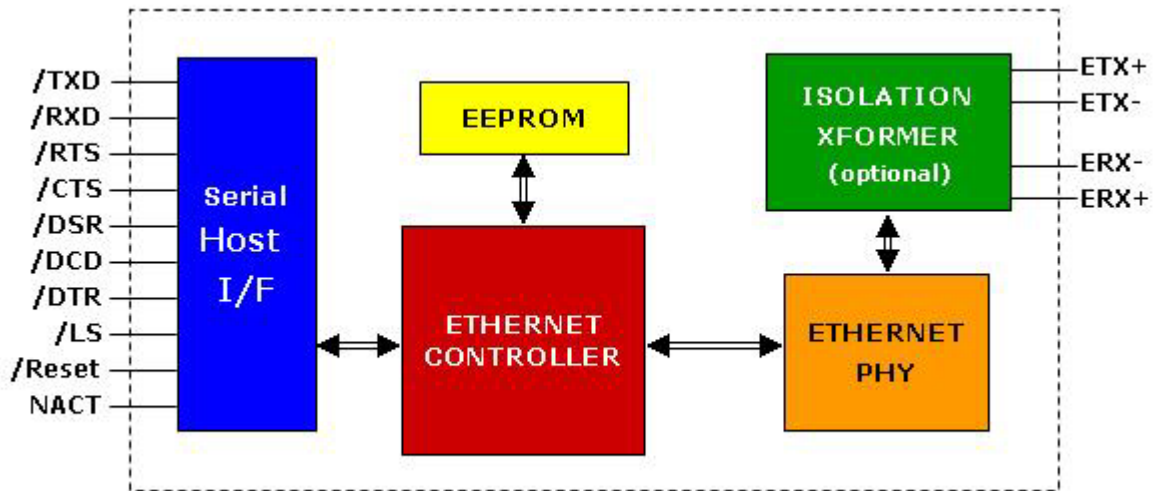

## XE232NET Mechanical Specifications

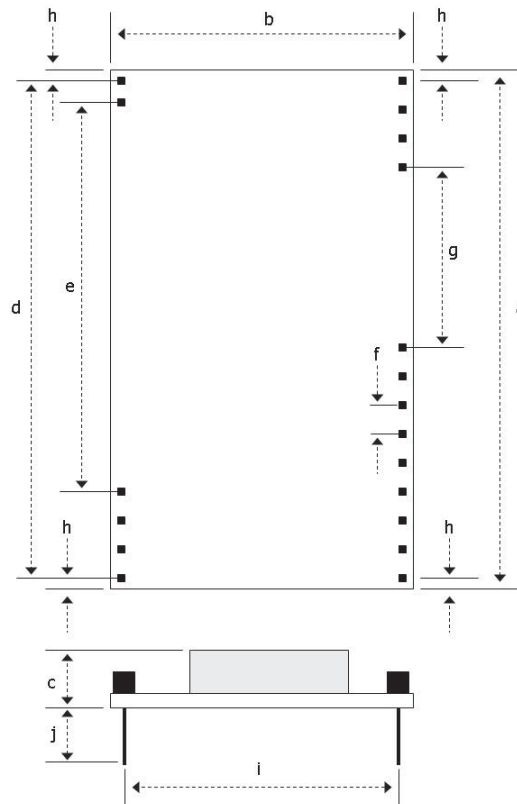

Dim	Description	Inches	MM
a	Module Length	2.10	53.3
b	Module Width	1.00	25.4
c	Module Height*	0.32	8.1
d	Total Pin Row Length	2.00	50.8
e	Pin 2 to Pin 3	1.50	38.1
f	Adjacent Pins	0.10	2.5
g	Pin 15 to Pin 16	0.90	22.9
h	Last Pin to edge	0.05	1.3
i	Pin Row to Pin Row	0.90	22.9
J	Pin Length	0.15	3.8

\* Module Height with onboard transformer, XE232NET-1  
Interface Pins are .025 inches square

### XE232NET Pin Configuration

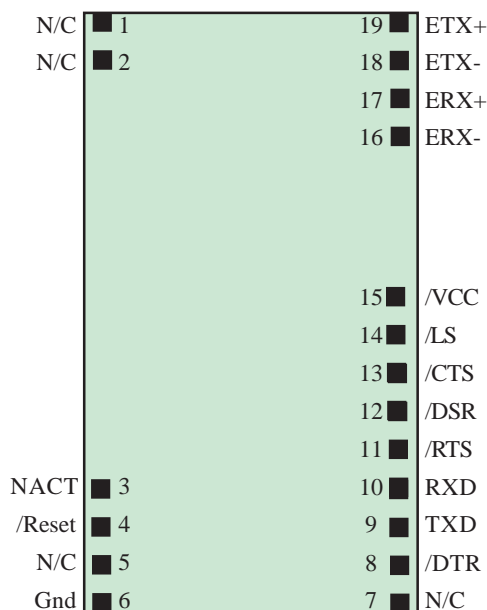

### Pin Descriptions

PIN	NAME	DESCRIPTION
1	N/C	No Connection
2	N/C	No Connection
3	NACT	Network Activity is an active high output from the Ethernet bridge indicating that the bridge is interacting with the network. NACT may be used to drive an LED to show when the Ethernet link is active.
4	/Reset	Reset is an active low input to the XE232NET. A low on this pin initiates a hardware reset. /RESET must be active for a minimum of 100 milliseconds to insure a proper reset. No external reset is required. This pin should be left open if Reset is not to be used.
5	N/C	No Connection
6	GND	Ground reference for the XE232NET
7	N/C	No Connection
8	/DTR	Data Terminal Ready input to the Ethernet Bridge. /DTR is an active low input indicating the host equipment is ready to communicate.
9	/TXD	Transmit Data input from the local host equipment.
10	/RXD	Received Data Output from the XE232NET to the local host.

## Pin Descriptions

PIN	NAME	DESCRIPTION
11	/RTS	Request to Send input to the Ethernet Bridge. An active Request to Send input indicates that the host equipment has information to send. Request to Send can also be used for hardware Flow Control. When used for hardware Flow Control, the host equipment turns Request to Send off to stop the flow of data from the XE232NET. Data Flow is resumed when Request to Send is reactivated.
12	/DSR	Data Set Ready is an active low output from the Ethernet Bridge. Data Set Ready is activated when the communications channel is available.
13	/CTS	Clear to Send is an active low output from the Ethernet Bridge. The XE232NET activates Clear to Send to indicate to the host equipment that it is ready to transmit data. When used as Hardware Flow Control, Request to Send is deactivated to stop the flow of data from the host to the XE232NET to prevent data buffers from overflowing. Data flow can resume when Clear to Send is reactivated.
14	/LS	Link Status is an active low output from the Ethernet Bridge. A low on this pin indicates that the Ethernet link is active. This pin may be used to drive an LED to display link status.
15	VCC	3.3 Volt power for the Ethernet Bridge module
16	ERX-	Ethernet Received Data Minus is the negative data input to the XE232NET module. Note: XE232NET-2 does not include the isolation transformer. That 1500 volt isolation barrier must be provided within the system.
17	ERX+	Ethernet Received Data Plus is the positive data input to the XE232NET module. Note: XE232NET-2 does not include the isolation transformer. That 1500 volt isolation barrier must be provided within the system.
18	ETX-	Ethernet Transmit Data Minus is the negative data output from the XE232NET module. Note: XE232NET-2 does not include the isolation transformer. That 1500 volt isolation barrier must be provided within the system.
19	ETX+	Ethernet Transmit Data Plus is the positive data output from the XE232NET module. Note: XE232NET-2 does not include the isolation transformer. That 1500 volt isolation barrier must be provided within the system.

## XE232NET Electrical Specifications

Parameter	Min	Typ	Max	Units	Comments
VCC	3.13	3.3	3.47	Volts	
ICC		145		mA	On Line
		0.35		mA	Sleep
Network Isolation	1500			VAC	XE232NET-1
Voh	2.4		5.0	Volts	
Vol			0.4	Volts	
Vih	2.0		5.0	Volts	
Vil	-0.3		0.8	Volts	

### XE232NET ABSOLUTE MAXIMUM RATINGS

Storage Temperature	-25° C to +85° C
<sup>1</sup> Maximum Operating Temperature Range	0° C to +70° C
VCC	3.6 Volts
<sup>1</sup> The XE232NET can be ordered with an Operating Temperature of -40° C to +85° C at extra cost. Order XE232NET-1ITR or XE232NET-2ITR to specify Industrial Temperature Range (ITR).	

## XE232NET-1 Typical Connection Diagram

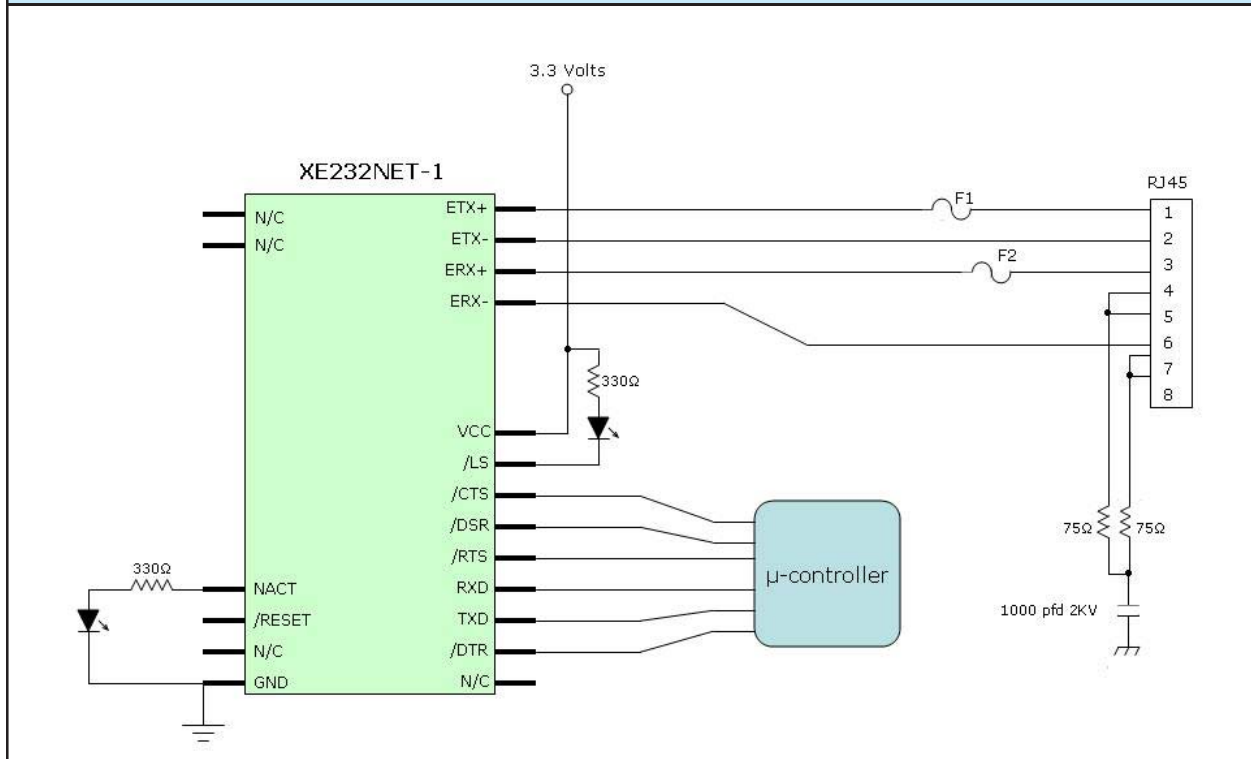

### Notes:

The Ethernet transformer is included on the XE232NET-1 module.

Fuses F1 and F2 protect against a power line cross with the network cable. Xecom recommends the Littlefuse 0461\_1.25 for this function

## XE232NET-2 Typical Connection Diagram

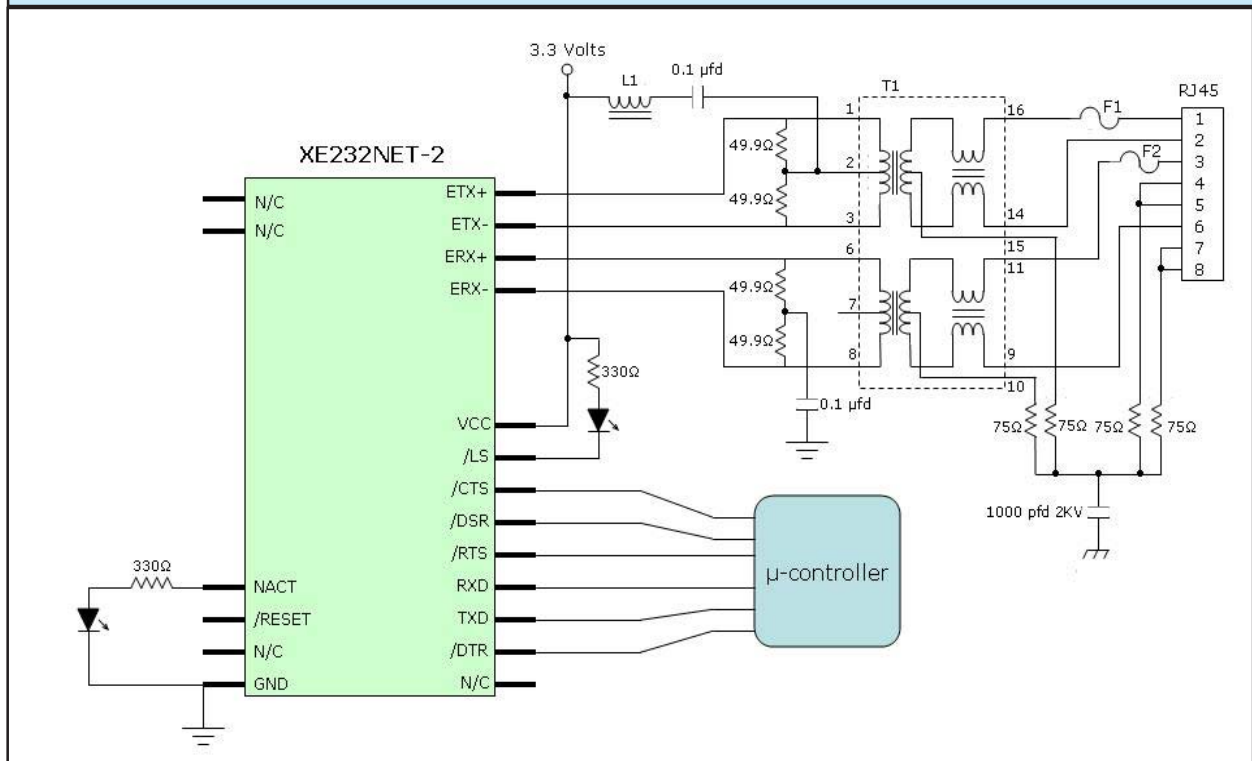

### Notes:

Fuses F1 and F2 protect against a power line cross with the network cable. Xecom recommends the Littlefuse 0461\_1.25 for this function

Transformer T1 is included on the XE232NET-1 module. For the XE232NET-2 Xecom recommends the Delta Electronics LF8505 Ethernet Transformer.

L1 is a Ferrite Bead for EMI Suppression.

---

## XE232NET AT Commands

The XE232NET uses "AT" commands for configuration and control. This section describes the AT command format and lists the commands, registers and result codes.

**Command Mode:** XE232NET enters command mode on power-up, reset, a lost connection, or receipt of the escape code. In command mode the modem accepts commands from the host on transmit data. Appropriate result codes are returned on received data.

### Command Line Format

AT commands follow a strict format. Each command line, except A/, begins with the prefix AT. The "A" and "T" may be both upper case or both lower case but cannot be of different cases.

Multiple commands may be combined into a single command line of up to 48 characters. Commands are executed in the sequence they appear upon receipt of a carriage return. Spaces inserted into the command line are not placed in the buffer.

The command line can be edited with a backspace before it is executed. The backspace erases the previous character in the command line. Register S5 allows the user to select a character other than backspace to edit the command line.

If the command buffer overflows, the modem issues an "ERROR" result code, and the command line is not executed. Register S3 allows the user to select a character other than a carriage return to terminate the command line.

**Re-Execute Last Command** - The A/ command causes the modem to re-execute the last command line. This is the only command which does not require the "AT" prefix.

**Omitted Parameters** - Most commands include a parameter which determines how the functions will be set. When the command parameter is omitted from the command string, it is assumed to be a 0.

**Escape Characters** - A 3 character escape sequence may be entered to switch the modem into command mode while on line. The escape character, set by Register S2, must be entered 3 times in succession to execute the escape. An AT command must then be entered within the period defined by S12 to enter command mode. The default escape sequence is "~~~"

**Result Codes** - The Ethernet Bridge issues a result code after each action. Result codes may be sent as full words, one or two digit numeric codes, or may be disabled all together. Each result code ends with a carriage return when numeric result codes are chosen. When full word result codes are chosen, a Line Feed and Carriage Return precede and follow each result code.

**Email Modes:** The XE232NET can transfer information as an Email from either of two Email modes, transmit and receive. Once Email uploading or downloading is complete the escape sequence, default "~~~", terminates Email mode.

Transmit Email mode is accessed with the AT+ET:n command. Where "n" represents the destination Email address. Upon receipt of this command the XE232NET logs into the Email Server and any data placed on TXD will be transferred to the destination address as Email.

The AT+ER command causes the XE232NET to log into the Email server and look for incoming Emails. Data from these received emails will be presented on the RXD output.



## XE232NET AT Commands

ATDa Send a message to Destination Address a within the local group.	AT\Pn Command Parity (when ATB2 or ATB5 is selected) n=0 even parity n=1 odd parity n=2 Mark Parity *
ATDw.x.y.z Send message to the IP address, w.x.y.z	
ATD:d Connect with listed domain name	
ATEn Command Echo n=0 Do not echo commands n=1 Echo commands to the system host.*	AT\Qn Terminal to adapter Flow Control; n=0 none n=3 Hardware (RTS/CTS) n=4 Software (XON/XOFF)
ATIn Module Identification codes n=0 Respond with Model Number n=1 Respond with Code Revision & Date	AT\Tn DTE interface Speed n=6 9600 bps n=9 19,200 bps * n=10 38,400 bps n=11 57,600 bps n=12 115,200 bps n=13 230,400 bps
ATQn Select Response Type n=0 Full Word Responses (includes a carriage return and linefeed before and after each response)* n=1 Single Character Responses (includes a carriage return after the response) n=2 No responses	AT+D=mm,dd,yy Set Date mm= month dd= day yy= year
ATZ Initiate a soft Reset	
AT&Cn This command controls the operation of the Line Status indicator /LS n=0 /LS always active n=1 /LS active when the Ethernet Link is available *	AT+ER: Causes the XE232NET to log into the Email server and download messages. AT+ET:n Causes the XE232NET to send data in Email form to address n.
AT&Dn Response to deactivation of /DTR n=0 Ignore /DTR n=1 Drop Ethernet Link if DTR inactive *	AT+Pn Password Requirement n=0 No Password required n=1 Password required to connect
AT&F Return to factory Default settings	AT+T=hh,mm,ss,n Set Time hh= hour mm= minute ss= second yy= year n= a for AM or P for PM
AT&V Display active configuration	
AT\Bn Character format for commands n=1 7N1; 7 data bits, no parity, one stop bit n=2 7P1; 7 data bits, one parity bit, one stop bit n=3 8N1; 8 data bits, no parity, one stop bit n=5 8P1; 8 data bits, one parity bit, one stop bit *	

---

## XE232NET Registers

- S1 **Automatically connect to network:** S0=1 sets the ethernet bridge to automatically complete a network connection. .
- S2 **Escape Character:** S2 sets the ASCII escape character. Values of 0-127 select valid characters; values from 128 to 255 disable the escape sequence.  
Range: 0 to 255  
Units ASCII Character  
Default 126 (~)
- S3 **Line Termination Character:** S3 determines the ASCII character which will terminate commands and modem responses.  
Range: 0 to 127  
Units ASCII Character  
Default 13 (Carriage Return)
- S4 **Line Feed Character:** S4 sets the ASCII character to act as a line feed character in modem responses.  
Range: 0 to 127  
Units ASCII Character  
Default 10 (Line Feed)
- S5 **Backspace Character:** S5 defines the ASCII character used as a backspace to edit the command line.  
Range: 0 to 127  
Units ASCII Character  
Default 8 (Back Space)
- S12 **Escape Code Guard Timer:** S12 sets the escape sequence guard timer. If characters are received before or after the escape sequence, within the guard timer, the modem aborts the escape and remains in data mode.  
Range: 10 to 255  
Units 0.02 Seconds  
Default 50
- S14 **Sleep Inactivity Timer:** S14 sets the length of inactivity before the Ethernet Bridge enters sleep mode. Zero disables sleep mode.  
Range: 0 to 255  
Units: Seconds  
Default: 0
- S99 **DHCP Client:** S99 Determines if DHCP (Dynamic Host Configuration Protocol) will be active.  
Range: 0 to 1  
Setting: 0 = DHCP Disabled  
1 = DHCP Enabled  
Default: 1
- S100 **Network Port Number:** S100 sets the port number of the XE232NET for the local network.  
Range: 0-65535  
Default: 0
- S101 **Set IP Address:** S101 sets the IP Address of the XE232NET. Note when DHCP is selected and the XE232NET is connected to a DHCP server the IP Address does not need to be set manually.  
Format: www.xxx.y.z
- S102 **Set Network Mask:** S102 sets the Network Mask of the XE232NET. Note when DHCP is selected and the XE232NET is connected to a DHCP server the Network Mask does not need to be set manually.  
Format: www.xxx.yyy.z
- S103 **Set Network Gateway:** S103 selects the Network Gateway for the XE232NET. Note when DHCP is selected and the XE232NET is connected to a DHCP server the Network Gateway does not need to be set manually.  
Format: www.xxx.yyy.z

---

## XE232NET Registers

S104 **Set DNS IP Address:** S103 selects the Domain Name Server Address for the XE232NET. Note when DHCP is selected and the XE232NET is connected to a DHCP server the Domain Name Server Address does not need to be set manually.  
Format: www.xxx.yyy.z

S105 **Set User Name:** S105 stores the User Name for the XE232NET. The User Name may be up to 8 ASCII characters. The default User Name is "USER". The User Name is not reset with the AT&F command

S106 **Set Password:** S106 stores the password for the XE232NET. The password may be up to 8 ASCII characters. The default Password is "PASSWORD". The password is not reset with the AT&F command.

## XE232NET Registers

<u>Digits</u>	<u>Verbose</u>	<u>Description</u>
0	OK	Command Successful
1	CONNECT	300 bps or higher connection
3	NO CARRIER	Link not detected
4	ERROR	Error in command line

---

## Terms of Sale

Devices sold by XECOM are covered by the warranty provisions appearing in its Terms of Sale only. XECOM makes no warranty, express, statutory, implied, or by description regarding the information set forth herein, or regarding the freedom of the described devices from patent infringement. XECOM makes no warranty of merchantability or fitness for any purposes. XECOM reserves the right to discontinue production and change specifications and prices at any time and without notice. This product is intended for use in normal commercial applications. Applications requiring extended temperature range, unusual environmental requirements, or high reliability applications, such as military, medical life-support or life-sustaining equipment, are specifically not recommended without additional processing and authorization by XECOM for such application.

Xecom assumes no responsibility for the use of any circuitry other than circuitry embodied in a Xecom product. No other circuits, patents, or licenses are implied.

## Life Support Policy

Xecom's products are not authorized for use as Critical Components in Life Support Devices or Systems.

**Life Support Devices or Systems** are devices or systems which, (a) are intended for surgical implant into the body, or (b) support or sustain life, and whose failure to perform, when properly used in accordance with instructions provided in the labeling, can be reasonably expected to result in significant injury to the user.

A **Critical Component** is any component of a life support device or system whose failure to perform can be reasonably expected to cause failure of the life support device or system, or to affect its safety or effectiveness.

Copyright, Xecom © 2007

While Xecom, Inc. has made every effort to ensure that the information presented here is accurate, Xecom will not be liable for any damages arising from errors or omission of fact. Xecom reserves the right to modify specifications and/or prices without notice. Product mentioned herein are used for identification purposes only and may be trademarks and/or registered trademarks of their respective companies.



**Xecom Incorporated**  
374 Turquoise Street, Milpitas, CA 95035  
Ph:408-942-2200 Fax:408-942-1346 E-Mail: info@xecom.com