

XGZP6167A PRESSURE TRANSMITTER

FEATURES

- Absolute Pressure Type
- Pressure range(0 ~ 1Mpa···2.5MPa)
- MEMS Silicon Sensor
- Smart and Exquisite, High Stability
- Anti-overload&Shock&Vibration
- For Non-corrosive gas or air or liquid
- Low Cost, Small Volume.



APPLICATIONS

- HVAC System
- Hydraulic/Pneumatic
- Refrigeration Systems
- Pumps and Compressor
- Industrial Process Control and Monitoring
- Agriculture, Metallurgy, Hydrology, Energy etc.,

INTRODUCTION

XGZP6167A Pressure Transmitter is high performance and low cost products. It is structured by Piezo-resistive MEMS silicon sensor as signal sensing element and the customized IC, assort with stainless steel housing and standard pressure port and wire connector.

XGZP6167A Transmitter is integrally temperature compensated and linearity corrected that can meet the requirement of measure and control under general environment. Through strict component making, semi-finished product and all-finished product testing and aging, the transmitter is stable and reliable, having excellent consistency and sensitivity.

XGZP6167A Transmitter provide standard analog output mode(0.5-4.5V or 4-20mA), the OEM service can meet extremely clients application requirement.

PERFORMANCE PARAMETER

Unless otherwise specified, measurements were taken with a temperature of $25 \pm 1^\circ\text{C}$ and humidity ranging from 25 % ~ 85%RH (supply voltage: $(5 \pm 0.25) \text{ V DC}$)

Item	Data	Unit
Accuracy(non-lin., rep. and hys...) ¹	± 1.5	%Span
Long Term Stability(1 Year) ²	± 0.25	%Span
Insulation Impedance (250Vdc)	250	MΩ
Over pressure ³	2×	Rated
Burst Pressure ⁴	3×	Rated
Pressure Circulation(Zero- Span)	1	Million
Compensation Temp. ⁵	-10 ~ 70	°C
Operating Temp.	-10 ~ 100(water)/-20 ~ 125(Gas)	°C
Storage Temp.	-40 ~ 125	°C
Housing Material	Brass, Stainless Steel, Aluminum etc.,	
ESD	± 4000	V
Protection Grade	IP65	

1 **Accuracy**: The max. deviation in output from ideal transfer function at any pressure or temperature over the specified ranges, units are in percent of full scale span (%FSS), which mainly consists of: Offset and Span; Linearity(Non-linearity); Repeatability; Total accuracy also include Pressure Hysteresis ; TcOffset and TcSpan.

1.1. The accuracy in table is the typical output accuracy during specified pressure range. Contact factory for higher accuracy requirement(e.g $\pm 0.5\%$ Span) if need.

1.2 Non-linearity(Linearity): the deviation of measured output from "Best Straight Line" through three points (Offset pressure, FS pressure and $\frac{1}{2}$ FS pressure)at constant temperature.

1.3 Repeatability: the deviation of measured output when the same pressure is applied continuously, with pressure approaching from the same direction within the specified operating pressure range, under the same operating conditions.

1.4 Pressure Hysteresis: the deviation of measured output at any pressure within the specified range, when this pressure is applied continuously, with pressure approaching from opposite directions within the specified operating pressure range, under the same operating conditions.

1.5 TcOffset (TCO:Temp. Coefficient of Offset): the deviation of measured output with minimum rated pressure applied, over the temperature range of 0° to 60°C , relative to 25°C .

1.6 TcSpan (TCS:Temp. Coefficient of Span): the deviation of measured output over the temperature range of 0° to 60°C , relative to 25°C .

2. **Long Term Stability**: the sensor's output deviation when subjected to 1000 hours pressure test or store for one year..

3. **Over Pressure**: the maximum pressure which may be applied without causing durable shifts of the electrical parameters of the sensing element and remain the specification once pressure is returned to the operating pressure range.

4. **Burst Pressure**: the maximum pressure which may be applied without causing damage to the sensing die or leaks; The sensor should not be expected to recover function after exposure to any pressure beyond the burst pressure.

5. **Compensated Temperature**: the temperature range over which the sensor have an output proportional to pressure within the specified performance limits.

DIMENSION (Unit:mm)&DEFINITION

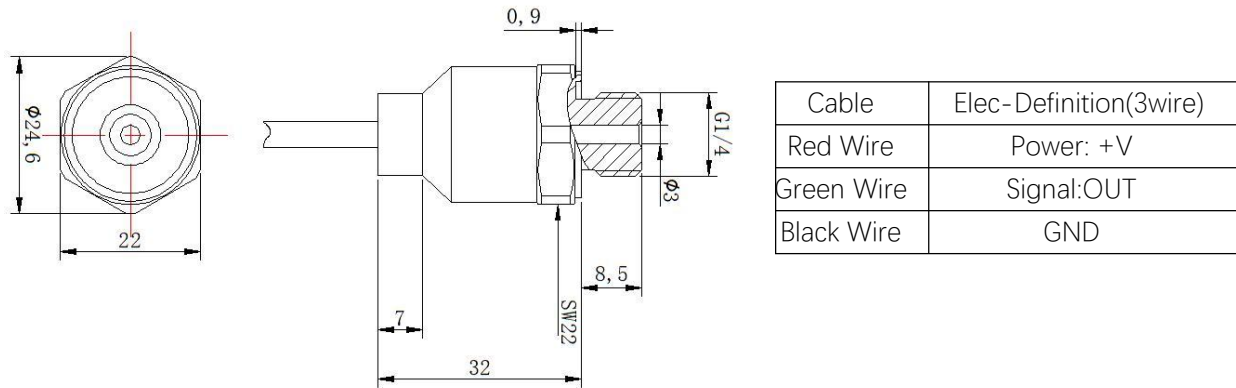

OUTPUT CURVE (5VDC Power Supply)

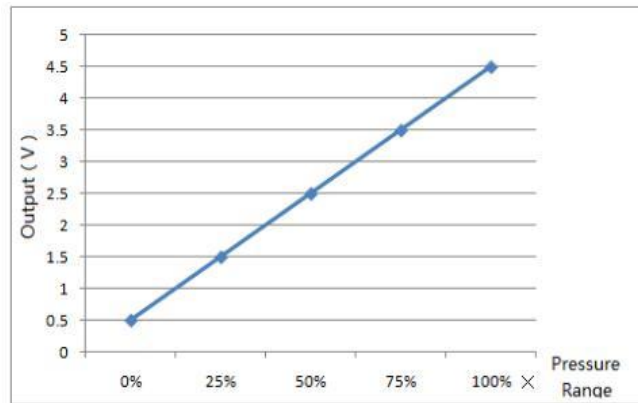

ORDER GUIDE

XGZP6167A	Pressure Transmitter			
	Range	0 ~ 1MPa、 1.6MPa、 2.5MPa		
	r0 ~ X1MPa	X:Calibration Range		
	Code	Output		
	K	0.5V ~ 4.5VDC		
		Code	Accuracy	
		3	±1%	
		4	±1.5%	
XGZP6167A	1MPa	K	3	Full Part Number

【 SAFETY NOTES 】

Using these sensors products may malfunction due to external interference and surges, therefore, please confirm the performance and quality in actual use. Just in case, please make a safety design on the device (fuse, circuit breaker, such as the installation of protection circuits, multiple devices, etc.), so it would not harm life, body, property, etc even a malfunction occurs.

To prevent injuries and accidents, please be sure to observe the following items:

- The driving current and voltage should be used below the rated value.
- Please follow the terminal connection diagram for wiring. Especially for the reverse connection of the power supply, it will cause an accident due to circuit damage such as heat, smoke, fire, etc.
- In order to ensure safety, especially for important uses, please be sure to consider double safety circuit configuration.
- Do not apply pressure above the maximum applied pressure. In addition, please be careful not to mix foreign matter into the pressure medium. Otherwise, the sensor will be discarded, or the media will be blown out and cause an accident.
- Be careful when fixing the product and connecting the pressure inlet. Otherwise, accidents may occur due to sensor scattering and the blowing out of the media.
- Because Pressure sensor body is sold, please be careful not to hurt your body when using it.

【 WARRANTY 】

The information in this sheet has been carefully reviewed and is believed to be accurate; however, no responsibility is assumed for inaccuracies. Furthermore, this information does not convey to the purchaser of such devices any license under the patent rights to the manufacturer. CFSensor reserves the right to make changes without further notice to any product herein. CFSensor makes no warranty, representation or guarantee regarding the suitability of its product for any particular purpose, nor does CFSensor assume any liability arising out of the application or use of any product or circuit and specifically disclaims any and all liability, including without limitation consequential or incidental damages. Typical parameters can and do vary in different applications. All operating parameters must be validated for each customer application by customer's technical experts. CFSensor does not convey any license under its patent rights nor the rights of others.

【 CONTACT 】

CFSensor

22F/14Bldg High-Tech Park High-Tech Area Wuhu P.R.C.241000

Tel/Fax: +86 18226771331 Email: INFO@CFSensor.com

North America || Europe || Southeast Asia || Middle East || Latin America