

XGZP6806D BAROMETRIC PRESSURE SENSOR

FEATURES

- Wide Ranges: 300 ... 1100hPa
- 1.8V ~ 3.6V Power Supply (1.2~3.6V (VDDIO))
- Absolute Pressure Type
- Current Consumption: 60uA
- Standby Current: <100nA (25°C)
- Calibrated Digital Signal(I2C Interface)
- Absolute Pressure Accuracy: $\pm 1\text{hPa}(8.3\text{m})$
- Relative Pressure Accuracy: $\pm 0.12\text{hPa}(1\text{m})$
- Temperature Accuracy: $\pm 1^\circ\text{C}$

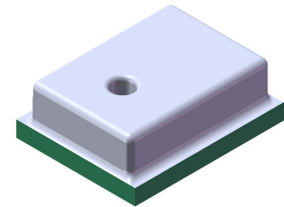

APPLICATIONS

- Enhancement of GPS navigation (dead-reckoning, slope detection, etc.)
- In- and out-door navigation
- Leisure and sports
- Weather forecast
- Vertical velocity indication (rise/sink speed)

INTRODUCTION

XGZP6806D is a perfect silicon pressure sensor offering a ratiometric I2C interface for reading pressure over the specified full scale pressure span.

The XGZP6806D is a miniaturized Digital Barometric Air Pressure Sensor with a high accuracy and a low current consumption. The XGZP6806D is both a pressure and a temperature sensor. The pressure sensor element is based on a capacitive sensing principle which guarantees a high precision during temperature changes. The small package makes the XGZP6806D ideal for mobile applications and wearable devices.

The XGZP6806D's internal signal processor converts the output from the pressure and temperature sensor elements to 24-bit results. Each pressure sensor has been calibrated individually and contains calibration coefficients. The coefficients are used in the application to convert the measurement results to true pressure and temperature values.

XGZP6806D pressure sensor is for high volume application at an affordable cost but perfect performance.

MAXIMUM RATE

Parameter	Condition	Min	Max	Units
Storage Temp.		-40	+125	°C
Power supply			+4	V
ESD	HBM	-2	+2	kV

PERFORMANCE PARAMETER

Unless otherwise specified, measurements were taken with a a temperature of 25±1°C and VDD1.8V.

Parameter	Symbol	Condition	Min	Typ.	Max	Units
Working Temp.	TA	Operational	-40	25	85	°C
		Full accuracy	0	25	70	°C
Pressure Range	P		300		1100	HPa
Power Supply	VDD		1.7		3.6	V
Digi-Power supply	VDDIO		1.2		3.6	V
Working Current	I _{dd}	1 Hz		2.8	3	uA
Peak Current	I _{peak}	Constant sampling		0.9	1.15	mA
Standby Current	I _{ddsbm}			5	100	nA
Absolute Accuracy	P _A	300-1100HPa @25°C		±1		HPa
Temp. Accuracy		@25°C		±1		°C
Relative Accuracy	P _R	950-1050HPa @25°C		±0.12		HPa
Sampling Rate	f		0.25		128	Hz
Measurment Time	t			4		ms

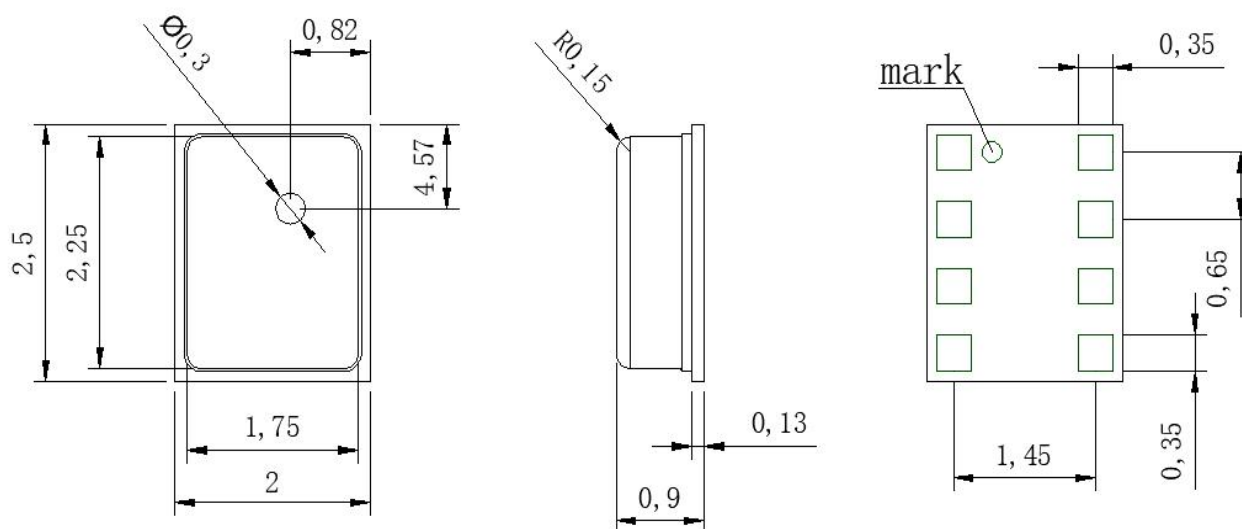
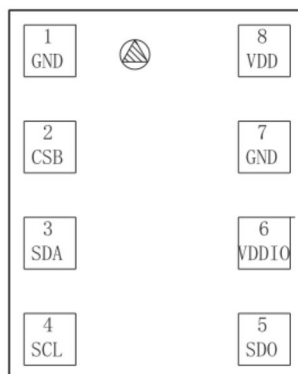
DIMENSION(mm)

ELECTRIC CONNECTION

Pin	Name	SPI 3-wire	SPI 3-wire with interrupt	SPI 4-wire	I2C	I2C with interrupt
1	GND	Ground				
2	CSB	Chip select -tie to GND	Chip select -tie to GND	Chip select -tie to GND	Not used - tie to VDDIO	Not used - tie to VDDIO
3	SDA	Serial data in/out	Serial data in/out	Serial data in	Serial data in/out	Serial data in/out
4	SCK	Serial Clock				
5	SDO	Not used	Interrupt	Serial data out	Least significant bit in the device address	Interrupt pin and least significant bit in the device address
6	VDDIO	Digital supply voltage for digital blocks and I/O interface				
7	GND	Ground				
8	VDD	Supply voltage for analog blocks				

Notes:

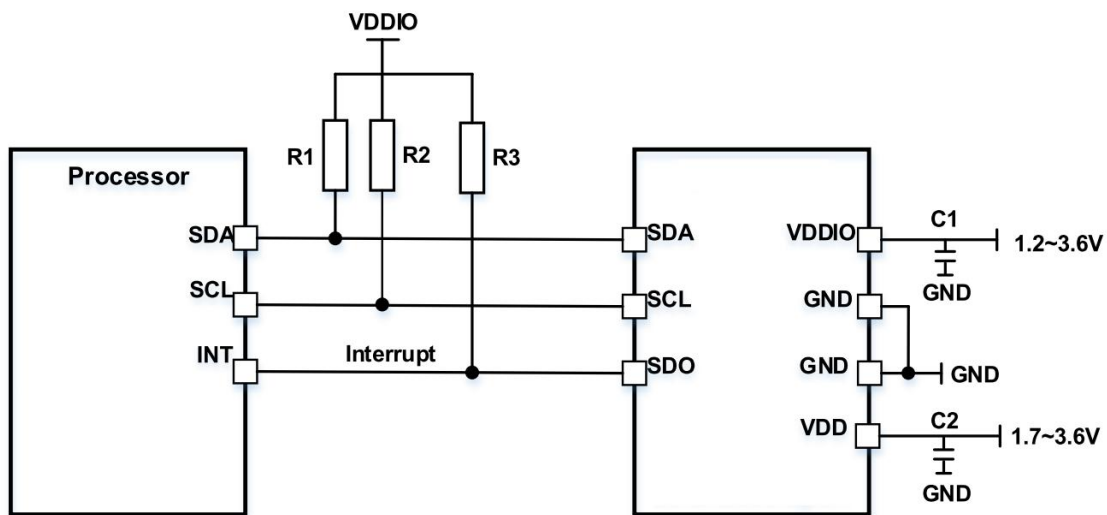
1. Implement ESD protection during whole soldering and assembly process.
2. Overload voltage(max.3.6Vdc) may burn the ASIC and cause the sensor fail throughly.
3. Don't connect NC pin to any electronical part
4. Don't make reverse connection because no reverse connection protection.
5. More details about soldering and storage etc., refer to [Overall notes](#).

TYP. APPLICATION

Component	Values			Unit	Note / Test Condition
	Min.	Typ.	Max.		
R1, R2		4.7	10	KΩ	
R3		3.3	10	KΩ	
C1, C2	100	100		nF	

MEASUREMENT METHOD

The XGZP6806 can measure both temperature and pressure or just pressure measurement. When the measurement is completed, the XGZP6806 can enter the standby mode by itself, or can enter the standby mode by sending the sleep mode command from the host.

XGZP6806 supports multiple working modes.

Standby Mode: This is the default mode after power on. No measurement is performed. All register values are accessible

Single-measurement Mode: Performs a pressure measurement after a temperature measurement, and returns to standby mode when the measurement is complete.

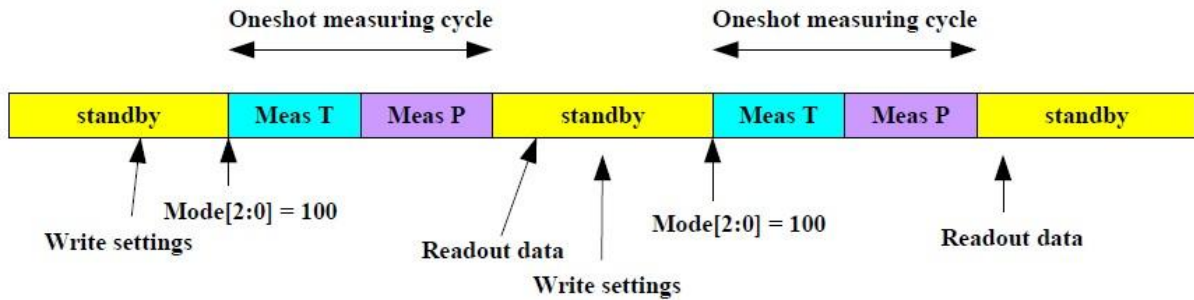

Cyclic Mode: Pressure and temperature measurements are performed in a continuous cycle according to the selected measurement rate and accuracy.

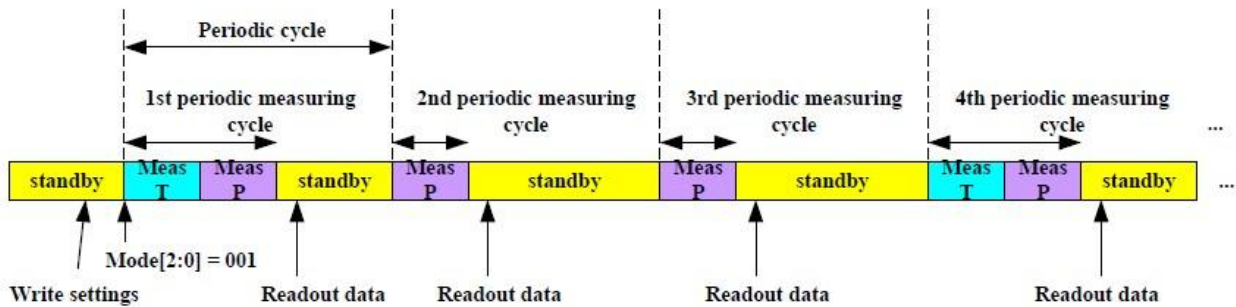

FIFO Mode: The XGZP6806 has a set of FIFO registers capable of storing 32 bridge sensor measurements. It helps to improve system power consumption. In FIFO mode, measurements are performed in a continuous loop until the FIFO register is filled with 32 measurements. Once the data is read and the FIFO register is not full, the measurement starts automatically until the data fills up again

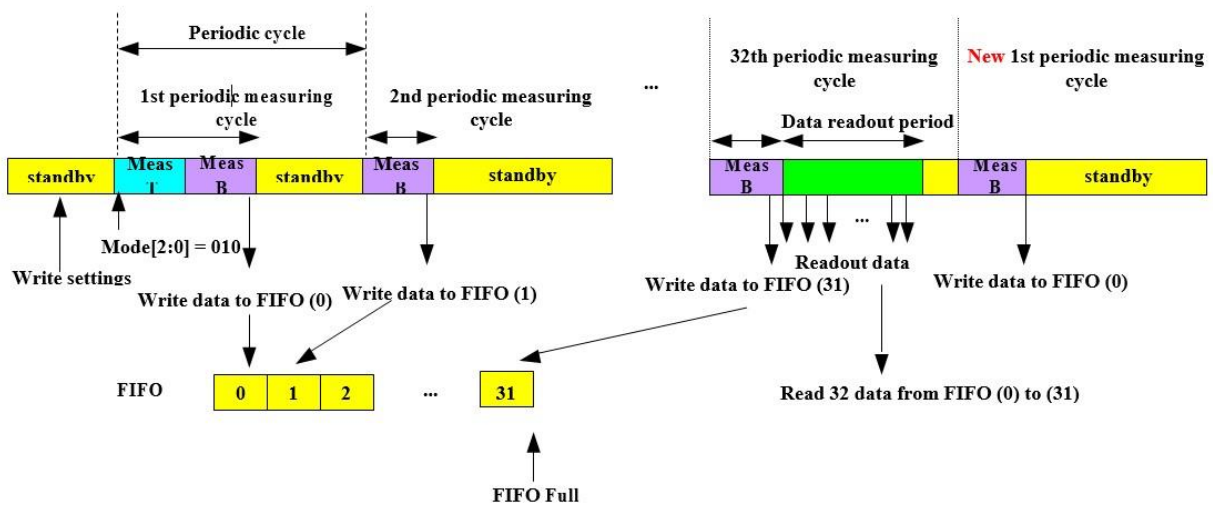

Cyclic-FIFO Mode: In this mode, the periodic mode is executed first, and when the measured value is greater or less than the threshold set by a specific configuration register, it will trigger to enter the FIFO mode. Threshold settings can be seen in the register table.

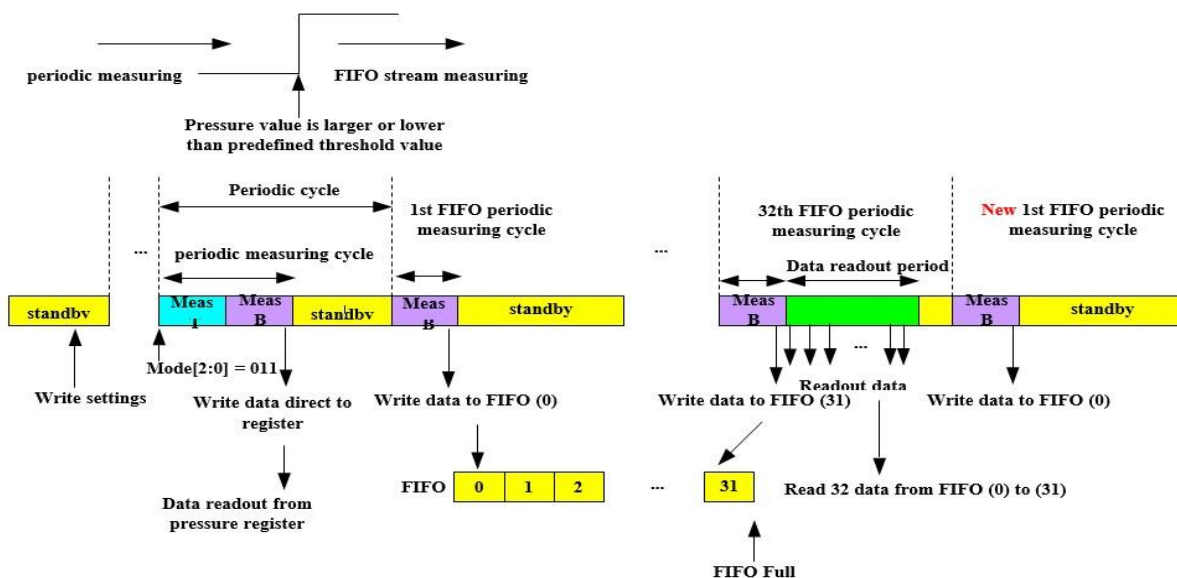

Pressure Data Output Rate

The pressure data output rate can be set through register 0x0F, ranging from 0.25 to 128Hz

Pressure Data Output Rate-Register Comparison Table (0x0F)

[7:4]	Output data rate of pressure data
0010	128 Hz
0011	64 Hz
0100	32 Hz
0101	16 Hz
0110	8 Hz
0111	4 Hz
1000	2 Hz
1001	1 Hz
1010	0.5Hz
1011	0.25Hz

Temperature Data Output Rate

When bit[3] in register 0x0F is set to "1", temperature measurement is disabled, otherwise temperature measurement is enabled. Bits[3:0] of Register 0x0F define the pressure to temperature output speed ratio and need to be used in conjunction with the output data rate setting bits[7:4] of the register. For example, when the output data rate for pressure data is selected as 8Hz, and the P/T ratio is selected as 8, the output data rate for temperature is 1Hz.

P/T Rate-Register Comparison Table(0x0F)

[3:0]	P/T ratio
0000	1
0001	2
0010	4
0011	8
0100	16
0101	32
0110	64
1xxx	No temperature

Data Interface(I2C)

The I2C interface of XGZP6806 can meet the standard mode ($\leq 100\text{KHz}$), fast mode ($\leq 400\text{KHz}$) and high-speed mode ($\leq 3.4\text{MHz}$), and provides 3 communication methods: single-byte write/single-byte read/multi-word Section read

The address is 1110001 (0x71).

The SDO pin should be connected to VDDIO and cannot be left floating, otherwise the I2C device address will have an undefined error.

I2C Write

				Control byte					Date byte																		
Start	Slave Address						RW	ACKS	Register address(13h)						ACKS	Register data - address 13h (0x22)						ACKS					
S	1	1	1	0	0	0	1	0		0	0	0	1	0	0	1	1		0	0	1	0	0	0	1	0	

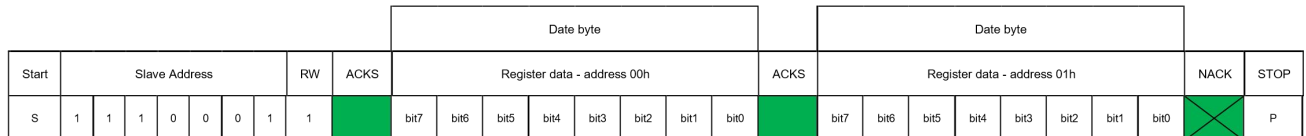
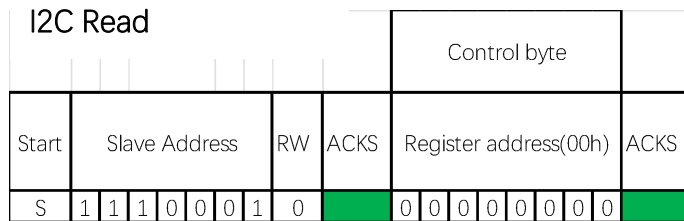

FIFO Mode

XGZP6806 can store 32 sets of pressure or temperature measurement values in FIFO mode. When the host does not need to continuously extract data from the sensor, it can enter standby mode for a long time, thus reducing the overall system power consumption.

- FIFO can be enabled through 0x0E register.
- If FIFO is enabled, the sensor will use 24-bit registers (0x00~0x02) to store pressure/temperature measurement results. The measurement type can be seen in the result data, when the least significant digit is '1', the result is the temperature measurement result, and when the least significant digit is '0', the result is the pressure measurement result.
- When reading FIFO data in multi-byte read mode, the register address will automatically increase, and the result of 0x00 will be automatically returned when it reaches 0x02.
- After each measurement is read out, the register address will be automatically incremented and the next result will be placed in the data register. When the FIFO is empty, the status register 0x08 will display the corresponding flag bit, and all subsequent reads will return the last read data.
- When the FIFO is full, the status register 0x08 will display the corresponding flag bit. The sensor can be interrupted by configuring register 0x0D.
- The number of data stored in FIFO can be obtained through register 0x0A.
- FIFO only contains pressure value by default. By configuring bit7 of register 0x0D, both pressure and temperature values can be obtained.

Data Read&Calculation

Calculate the compensated pressure value:

1. Read the pressure raw data from the register (0x00~0x02)
2. Convert by the following formula:

$$P_{(kPa)} = \frac{raw}{2^{24}} * 150$$

Calculate the compensated temperature value:

1. Read the temperature raw data from the register (0x03~0x05)
2. Convert by the following formula:

$$T_{(°C)} = \frac{T_{raw}}{2^{24}} * 125 - 40$$

Register Table

Byte	Name	Description	Type	B7	B6	B5	B4	B3	B2	B1	B0	Default
00H	PSR2	Pressure data reading MSB	R	PSR[23:16]								00H
01H	PSR1	Pressure data reading LSB	R	PSR[15:8]								00H
02H	PSR0	Pressure data reading XLSB	R	PSR[7:0]								00H
03H	TMR2	Temperature data reading MSB	R	TMR[23:16]								00H
04H	TMR1	Temperature data reading LSB	R	TMR[15:8]								00H
05H	TMR0	Temperature data reading XLSB	R	TMR[7:0]								00H
08H	STAX	Chip status flag	R	STA[7:0]								00H
09H	IDX	Chip ID and revision ID	R	CID[3:0]				RID[3:0]				14H
0AH	FIFOX	FIFO status	R	FIFO[4:0]								
0DH	INTX	Interrupt control	RW	INT[7:0]								00H
0EH	MODX	Mode control	RW	MOD[3:0]				NR				00H
0FH	ODRX	Output data rate control	RW	PODR[3:0]				PTR[3:0]				90H
19H	USH2	Upper threshold MSB	RW	USH[23:16]								20H
1AH	USH1	Upper threshold LSB	RW	USH[15:8]								00H
1BH	USH0	Upper threshold XLSB	RW	USH[7:0]								00H
1CH	LSH2	Lower threshold MSB	RW	LSH[23:16]								00H
1DH	LSH1	Lower threshold LSB	RW	LSH[15:8]								01H
1EH	LSH0	Lower threshold XLSB	RW	LSH[7:0]								00H

Chip Config Register

Byte	Bit	Name	Type	Description	Default
08H	[7:0]	STA [7] [6] [5] [4] [3] [2] [1] [0]	R	Status flag indicator: Booting flag: 0: Booting now; 1: Boot process done FIFO empty: 0: FIFO has data; 1: FIFO is empty FIFO full: 0: FIFO is not full; 1: FIFO is full FIFO half: 0: FIFO <16; 1: FIFO >16 Reserved Over threshold: 0: Data in-bound; 1: Data > threshold; Under threshold: 0: Data in-bound; 1: Data < threshold; Data ready: 0: Measuring; 1: Data ready	00H
09H	[7:0]	/	R	Revision ID	14H
0AH	[4:0]	FIFO [4:0]		FIFO content: 00H: FIFO is empty 1FH: FIFO is full	00H

Software Reset

Byte	Bit	Name	Type	Description	Default
0CH	[7:0]	RST[7:0]	W	Software reset for whole chip: '10100101': Reset whole chip 'XXXXXXX1': Reset FIFO	--

Interrupt Instruction

Byte	Bit	Name	Type	Description	Default
0DH	[7]	INT [7] [6] [5] [4] [3] [2] [1] [0]	RW	Interrupt control: If FIFO contains temperature value. 0: No temperature value is stored in FIFO; 1: Pressure and temperature are both stored in FIFO Reserved If FIFO full: 0: Do not act; 1: Generate INT; If FIFO over half: 0: Do not act; 1: Generate INT; Reserved If data > threshold: 0: Do not act; 1: Generate INT; If data < threshold: 0: Do not act; 1: Generate INT; If data is ready: 0: Do not act; 1: Generate INT;	00H

System Control

Byte	Bit	Name	Type	Description	Default
0EH	[7]	ROW	RW	Output row data: 0= Calibrated data 1= Get row data;	0
0EH	[6:4]	MOD[2:0]	RW	Operation mode: 000: Sleep mode 001: Periodic 010: FIFO 011: Periodic to FIFO 100: One shot 101: / 110: / 111: /	000
0EH	[3:0]	(Reserved)	RW		0000
0FH	[7:4]	PODR[3:0]	RW	Output data rate of pressure sensor: 0010:128 Hz 0011:64 Hz 0100:32 Hz 0101:16 Hz 0110:8 Hz 0111:4 Hz 1000:2 Hz 1001:1 Hz 1010:0.5Hz 1011:0.25Hz	1001
0FH	[3:0]	PTR[3:0]	RW	Output data rate ratio between (P/T): bit[3] is reserved 0000: 1 0100: 16 0001: 2 0101: 32 0010: 4 0110: 64 0011: 8 1xxx: No temperature	0000
13H	[7:4]	POSR[3:0]	RW	Over sampling rate of bridge sensor (table 4-13, type A)	0010
13H	[3:0]	TOSR[3:0]	RW	Over sampling rate of temperature sensor: (table 4-13, type A)	0010
19H~1BH	[7:0]	USH	RW	Upper threshold	20-00-00H
1CH~1EH	[7:0]	LSH	RW	Lower threshold	00-01-00H

PACKING INFORMATION

Tape&Reel(unit: mm) QTY/reel: 10,000 pcs.

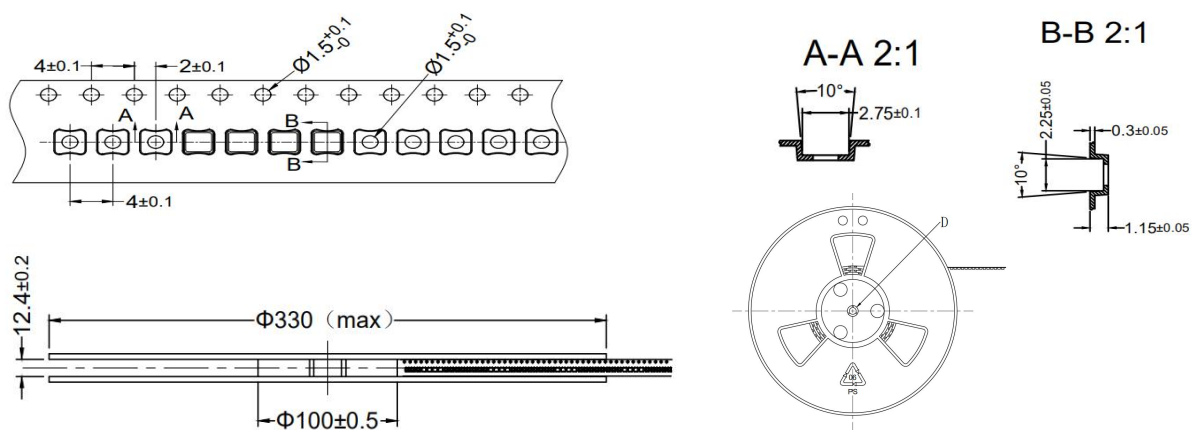

OVERALL NOTES

Unless otherwise specified, following notes are general attention or presentation for all products from CFSensor.

Mounting

The following steps is for transmitting the air pressure to sensor after sensor soldering on PCB.

- ▼ For some sensors that come with inlet tube, select the flexible pipe to suit the pressure inlet that is firm enough to prevent the pressure leaks.
- ▼ Atmosphere hole (for Gauge type sensors) and Inlet pipe/hole can't be blocked with gel or glue etc..
- ▼ Avoiding excessive external force operation

Soldering

Due to its small size, the thermal capacity of the pressure sensor is low. Therefore, take steps to minimize the effects of external heat. Damage and changes to characteristics may occur due to heat deformation. Use a non-corrosive resin type of flux. Since the pressure sensor is exposed to the atmosphere, do not allow flux to enter inside.

▼ Manual soldering

- ⊙ Raise the temperature of the soldering tip between 260 and 300°C/500 and 572°F (30 W) and solder within 5 seconds.
- ⊙ The sensor output may vary if the load is applied on the terminal during soldering.
- ⊙ Keep the soldering tip clean.

▼ DIP soldering (DIP Terminal)

- ⊙ Keep the temperature of the DIP solder tank below 260°C/500 and solder within 5 seconds.
- ⊙ To avoid heat deformation, do NOT perform DIP soldering when mounting on the PCB which has a small thermal capacity.

▼ Reflow soldering (SMD Terminal)

- ⊙ The recommended reflow temperature profile conditions are given below.

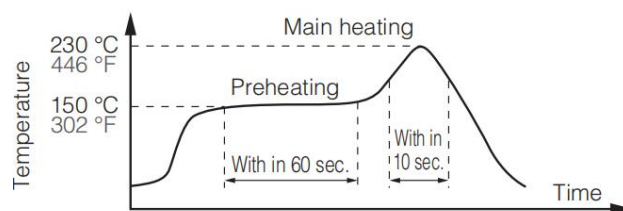

- ⊙ Self alignment may not always work as expected, therefore, please carefully note the position of the terminals and pattern.
- ⊙ The temperature of the profile is assumed to be a value measured with the PCB of the terminal neighborhood.
- ⊙ Please evaluate solderability under the actual mounting conditions since welding and deformation of the pressure inlet port may occur due to heat stress depending on equipments or conditions.

▼ Rework soldering

- ⊙ Complete rework at a time.
- ⊙ Use a flattened soldering tip when performing rework on the solder bridge. Do not add the flux.
- ⊙ Keep the soldering tip below the temperature described in the specifications.
- ▼ Avoid drop and rough handling as excessive force may deform the terminal and damage soldering characteristics.
- ▼ Keep the circuit board warpage within 0.05 mm of the full width of the sensor.
- ▼ After soldering, do not apply stress on the soldered part when cutting or bending the circuit board.
- ▼ Prevent human hands or metal pieces from contacting with the sensor terminal. Such contact may cause anomalous outlets as the terminal is exposed to the atmosphere.
- ▼ After soldering, prevent chemical agents from adhering to the sensor when applying coating to avoid insulation deterioration of the circuit board.

Connecting

- ▼ Correctly wire as in the connection diagram. Reverse connection may damage the product and degrade the performance.
- ▼ Do not use idle terminals(N/C) to prevent damages to the sensor.

Cleaning

- ▼ Since the pressure sensor is exposed to the atmosphere, do not allow cleaning fluid to enter inside from atmosphere hole (for Gauge type sensors) and inlet pipe.
- ▼ Avoid ultrasonic cleaning since this may cause breaks or disconnections in the wiring.

Environment

- ▼ Please avoid using or storing the pressure sensor in a place exposed to corrosive gases (such as the gases given off by organic solvents, sulfurous acid gas, hydrogen sulfides, etc.) which will adversely affect the performance of the pressure sensor chip.
- ▼ Since this pressure sensor itself does not have a water-proof construction(even available media can be liquid), please do not use the sensor in a location where it may be sprayed with water, etc.
- ▼ Avoid using the pressure sensors in an environment where condensation may form. Furthermore, its output may fluctuate if any moisture adhering to it freezes.
- ▼ The pressure sensor is constructed in such a way that its output will fluctuate when it is exposed to light. Especially when pressure is to be applied by means of a transparent tube, take steps to prevent the pressure sensor chip from being exposed to light.
- ▼ Avoid using pressure sensor where it will be susceptible to ultrasonic or other high-frequency vibration.
- ▼ Keeping the sensors sealed in static shielding bags with an oxygen-free condition and use the sensor as soon as possible once unfold the package, because the sensors' PINs may be oxidated a bit under atmosphere environment(slight oxidation wouldn't affect soldering and performance)

More Precautions

- ▼ That using the wrong pressure range or mounting method may result in accidents.
- ▼ The only direct pressure medium you can use is non-corrosive gas or air as illuminated above(Note: some sensors are compatible with liquid media). The use of other media, in particular, corrosive gases and liquid (organic solvent based, sulfurous acid based, and hydrogen sulfide based, etc.) or contains foreign substances will cause malfunction and damage. Please do not use them and check with CFSensor.
- ▼ The pressure sensor is positioned inside the pressure inlet. Never poke wires or other foreign matter through the pressure inlet since they may damage the sensor or block the inlet. Avoid use when the atmospheric pressure inlet(only for Gauge type pressure sensor) is blocked.
- ▼ Use an operating pressure which is within the rated pressure range. Using a pressure beyond this range may cause damage.
- ▼ Since static charge can damage the pressure sensor, bear in mind the following handling precautions.
 - When storing the pressure sensor, use a conductive material to short the pins or wrap the entire sensor in aluminum foil. Common plastic containers should not be used to store or transport the sensor since they readily become charged.
 - When using the pressure sensor, all the charged articles on the bench surface and the work personnel should be grounded so that any ambient static will be safely discharged.
- ▼ Based on the pressure involved, give due consideration to the securing of the pressure sensor.

【 SAFETY NOTES 】

Using these sensors products may malfunction due to external interference and surges, therefore, please confirm the performance and quality in actual use. Just in case, please make a safety design on the device (fuse, circuit breaker, such as the installation of protection circuits, multiple devices, etc.), so it would not harm life, body, property, etc even a malfunction occurs. To prevent injuries and accidents, please be sure to observe the following items:

- The driving current and voltage should be used below the rated value.
- Please follow the terminal connection diagram for wiring. Especially for the reverse connection of the power supply, it will cause an accident due to circuit damage such as heat, smoke, fire, etc.
- In order to ensure safety, especially for important uses, please be sure to consider double safety circuit configuration.
- Do not apply pressure above the maximum applied pressure. In addition, please be careful not to mix foreign matter into the pressure medium. Otherwise, the sensor will be discarded, or the media will blow out and cause an accident.
- Be careful when fixing the product and connecting the pressure inlet. Otherwise, accidents may occur due to sensor scattering and the blowing out of the media.
- If the sensor come with sharp PIN, please be careful not to hurt your body when using it.

【 WARRANTY 】

The information in this sheet has been carefully reviewed and is believed to be accurate; however, no responsibility is assumed for inaccuracies. Furthermore, this information does not convey to the purchaser of such devices any license under the patent rights to the manufacturer. CFSensor reserves the right to make changes without further notice to any product herein. CFSensor makes no warranty, representation or guarantee regarding the suitability of its product for any particular purpose, nor does CFSensor assume any liability arising out of the application or use of any product or circuit and specifically disclaims any and all liability, including without limitation consequential or incidental damages. Typical parameters can and do vary in different applications. All operating parameters must be validated for each customer application by customer's technical experts. CFSensor does not convey any license under its patent rights nor the rights of others.

【 CONTACT 】**CFSensor**

22F/14Bldg High-Tech Park High-Tech Area Wuhu P.R.C.241000

Tel/Fax:+86 18226771331 Email:INFO@CFSensor.com

North America || Europe || Southeast Asia || Middle East || Latin America