

XGZP6859D PRESSURE SENSOR

FEATURES

- Wide Ranges: -100kPa~0kPa~200kPa(show in [Pressure Range Example](#))
- Optional 2.5V ~ 5.5V Power Supply
- Gage(Positive&Vacuum) Type
- For Non-corrosive Gas or Air
- Calibrated Digital Signal(I2C Interface)(Refer to XGZP6859A for Analog signal)
- Temp. Compensated: 0°C ~ +60°C(32°F ~ +140°F)
- Current Consumption: 5uA(single measurement)
- Standby Current: <100nA (25°C)

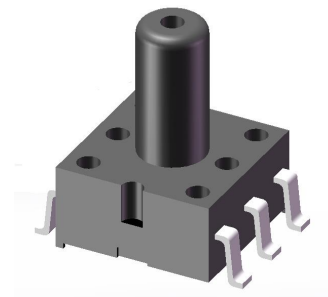

✓ RoHS

APPLICATIONS

- Medical&Healthy: e.g. ventilators, CPAP, NPWT, DVT, blood analysis, blood pressure monitoring, drug dosing, hospital beds, oxygen concentrators, patient monitoring, sleep apnea equipment, urine analyzers and wound therapy, breast pumps, massage device etc.
- Consumer&Household: e.g. Robot, UAV, wearable device, coffee makers, washing machines, vacuum cleaners, hand dryers, air pump, air beds etc.
- Industrial&Automation: e.g. HVAC, flow and liquid level measurement, process control and monitoring, life sciences, pressure switch and meter, IoT and automotive application etc.

INTRODUCTION

XGZP6859D is a perfect silicon pressure sensor offering a ratiometric digital data(I2C interface) for reading pressure and temperature over the specified full scale pressure span.

The XGZP6859D incorporates a silicon piezoresistive pressure sensor die and an interior Application Specific Integrated Circuit(ASIC) in a SMT package.

The XGZP6859D is fully calibrated and temperature compensated for specified span, so XGZP6859D pressure sensor satisfy the perfect accuracy, which is designed for a wide range of application in medical care&health, home appliances, consumer electronic, industry, automotive, IoT and other pneumatic devices etc by utilizing a microcontroller or microprocessor with D/A inputs.

XGZP6859D pressure sensor is for high volume application at an affordable cost and perfect performance.

Customized calibration parameter (e.g.pressure range etc.) are available.

PERFORMANCE PARAMETER

Unless otherwise specified, measurements were taken with a temperature of $25 \pm 1^\circ\text{C}$ and humidity from 25% ~ 85%RH.

Item	Data	Unit	Remark
Available Pressure Range ¹	<u>-100~0~200</u>	kPa	Customization acceptable
Power Supply ²	2.5~5.5	Vdc	
Max. Excitation Current	3	mA	
ADC Resolution ³	24	Bit	
SDA/SCL pull up resistor	4.7	Kohm	
ESD HBM	4000	V	
Total Accuracy ⁴	10kPa < Pressure \leq 200kPa	± 2	%Span Customization acceptable
	Pressure \leq 10kPa or > 200kPa	± 2.5	
Long Term Stability ⁵	± 0.5	%Span	
Over Pressure ⁶	Pressure \leq 5kPa	5X	Rated Pressure Differ on specific pressure range
	5kPa < Pressure \leq 200kPa	2.5X	
Burst Pressure ⁷	Pressure \leq 5kPa	10X	
	5kPa < Pressure \leq 200kPa	3X	
Compensation Temp. ⁸	0 ~ 60/32 ~ 140	$^\circ\text{C}/^\circ\text{F}$	Customization acceptable
Operating Temp. ⁹	-20 ~ 100/-4 ~ 212	$^\circ\text{C}/^\circ\text{F}$	
Storage Temp.	-30 ~ 125/-22 ~ 257	$^\circ\text{C}/^\circ\text{F}$	
Response Time ¹⁰	2.5	mS	

1 **Pressure Range(Operating pressure)**: The available pressure range including various span, not a specific pressure range.

2 **Power supply**: The default test voltage value: 3.3V, available working power supply voltage range:2.5 ~ 5.5V

3 **ADC Resolution**: The ADC resolution is defined as the smallest incremental voltage that can be recognized and thus causes a change in the digital output.

4 **Total Accuracy**: The max. deviation in output from ideal transfer function at any pressure or temperature over the specified ranges, units are in percent of full scale span (%FSS), which mainly consists of: Offset and Span Shift;Linearity(Non-linearity); Repeatability; Pressure Hsteresis ; TcOffset and TcSpan.

4.1. The accuracy in table is the typical output accuracy. The accuracy is not identical accroding to different specified pressure range. Contact factory for more information or for higher accuracy requirement(e.g $\pm 1\%$ Span) if need.

4.2 Non-linearity(Linearity): the deviation of measured output from "Best Straight Line" through three points (Offset pressure, FS pressure and $\frac{1}{2}$ FS pressure)at constant temperature.

4.3 Repeatability: the deviation of measured output when the same pressure is applied continuously, with pressure approaching from the same direction within the specified operating pressure range,under the same operating conditions.

4.4 Pressure Hysteresis: the deviation of measured output at any pressure within the specified range, when this pressure is applied continuously, with pressure approaching from opposite directions within the specified operating pressure range, under the same operating conditions.

4.5 TcOffset (TCO:Temp. Coefficient of Offset): the deviation of measured output with minimum rated pressure applied, over the temperature range of 0° to 60°C , relative to 25°C .

4.6 TcSpan (TCS:Temp. Coefficient of Span): the deviation of measured output over the temperature range of 0° to 60°C , relative to 25°C .

5. **Long Term Stability**: the sensor's output deviation when subjected to 1000 hours pressure test.

6. **Over Pressure** (Proof pressure): the maximum pressure which may be applied without causing durable shifts of the electrical parameters of the sensing element and remain the specification once pressure is returned to the operating pressure range.
7. **Burst Pressure**: the maximum pressure which may be applied without causing damage to the sensing die or leaks; The sensor should not be expected to recover function after exposure to any pressure beyond the burst pressure.
8. **Compensated Temperature**: the temperature range over which the sensor have an output proportional to pressure within the specified performance limits.
9. **Operating Temperature** (or Ambient Temperature): the temperature range over which the sensor have an output proportional to pressure but may not remain within the specified performance limits.
10. **Response Time**: it is defined as the time for the incremental change in the output from 10% to 90% of its final value when subjected to a specified step change in pressure.

ELECTRICAL CHARACTERISTICS(Interior ASIC)

Parameter	Min.	Typ.	Max.	Unit	Notes
LDO Output	1.62	1.8	1.98	V	'regulator_sel'= 0
	3.24	3.6	3.96	V	'regulator_sel'= 1
PSRR		60		dB	
Input Common Mode Rejection Ratio	80	110			
Interior Temp. Sensor Accuracy			±0.5	°C	@25°C
			±1	°C	-40 to 85 °C
Temp.Output Data Resolution	16			Bit	LSB = (1/256) °C
I2C Clock frequency			400	khz	I2C interface

BLOCK DIAGRAM

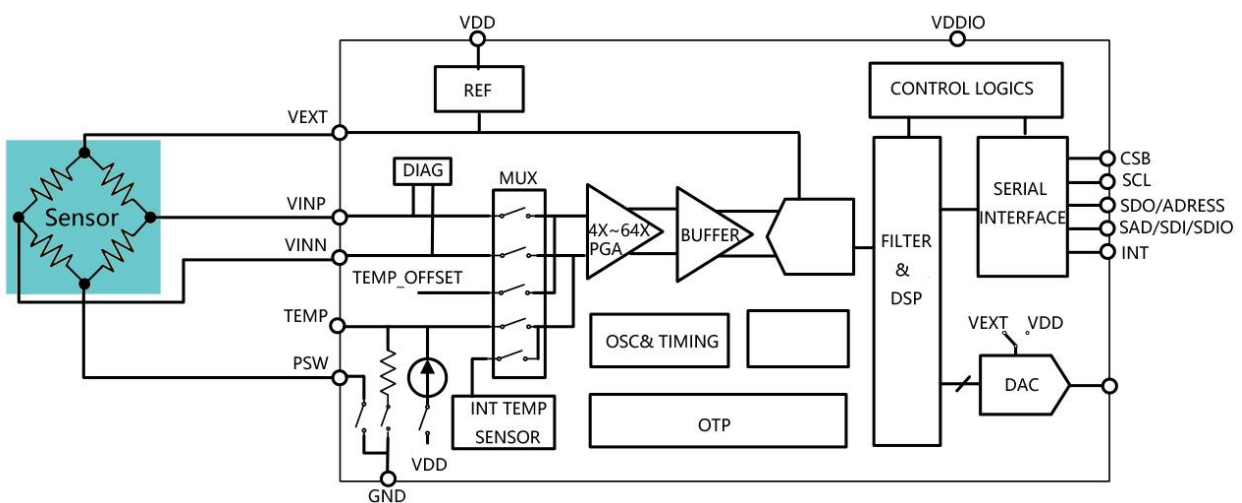

DIMENSION (Unit:mm)

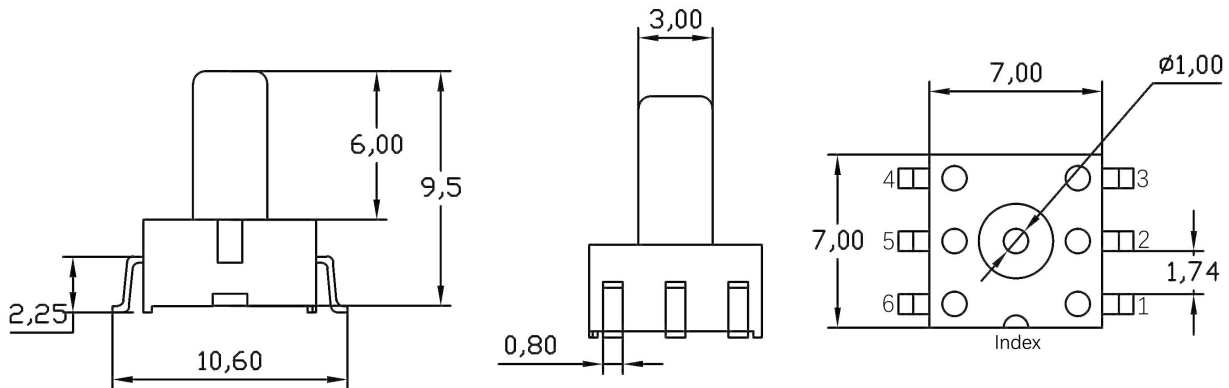

ELECTRIC CONNECTION

1	2	3	4	5	6
NC	VDD	NC	SDA	SCL	GND

NAME	FUNCTION
NC	Do not connect to external circuitry or ground
VDD	Voltage supply
SDA	Data signal(Send& Receive)
SCL	The clock signal
GND	Ground

CIRCUIT DIAGRAM

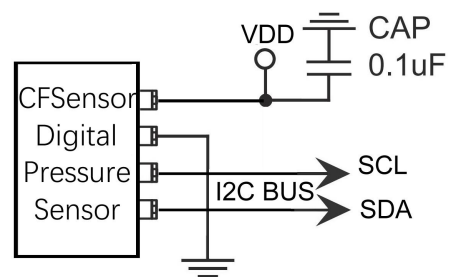

Note: Diagram state schematic connection only;
Check Pin allocation in Dimension drawing.

CROSS SECTION

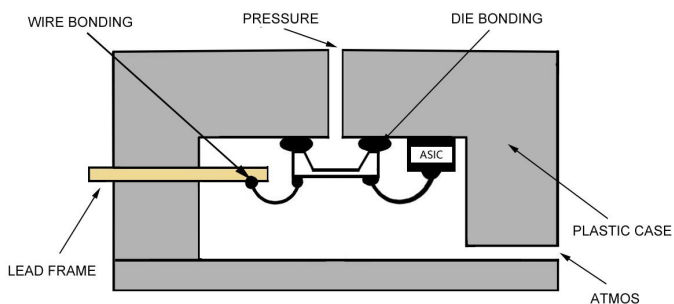

FOOTPRINT(REFERENCE)

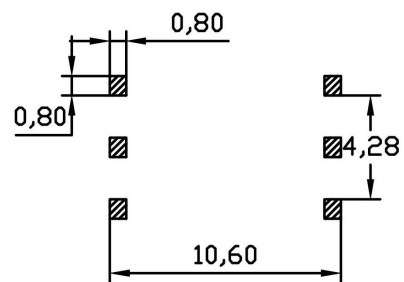

Unit: mm

Notes:

- 1.Implement ESD protection during whole soldering and assembly process.
- 2.Overload voltage(max.6.5Vdc) or current(max.5mA) may burn the ASIC and cause the sensor fail throughly.
- 3.More details about soldering and storage etc., refer to [Overall notes](#).

ORDER GUIDE

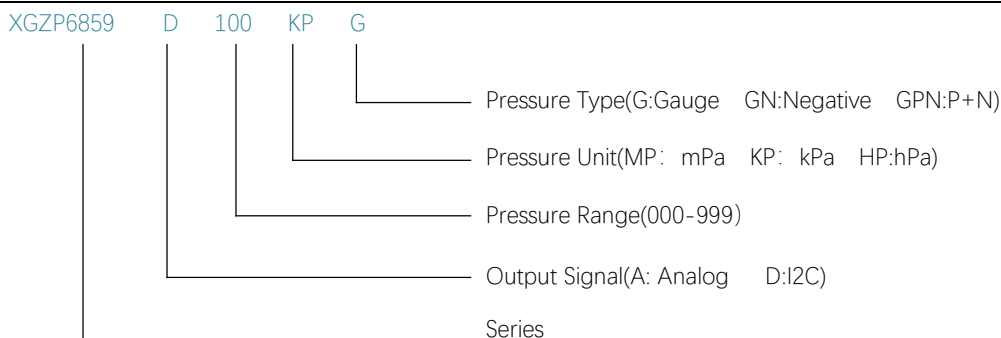

Note: Custom requirement or parameter, please consult CFSensor and comment custom code herewith Part number.

PRESSURE RANGE EXAMPLE

- Notes: 1. Unit conversion: 1000hPa=1000mbar≈750mmHg≈100kPa≈14.5PSI≈10mH₂O≈1bar=0.1MPa;
 2. Available for more custom pressure range e.g. -7 ~ 7kPa, , 0-700kPa etc.,

Pressure Range (kPa)	Pressure Range (by other units)	Part Number
0 ~ 2.5	0 ~ 25mbar / 0 ~ 250mmH ₂ O	XGZP6859D 025HPG
0 ~ 5	0 ~ 50mbar / 0 ~ 500mmH ₂ O	XGZP6859D 005KPG
0 ~ 10	0 ~ 100mbar / 0 ~ 75mmHg	XGZP6859D 010KPG
0 ~ 20	0 ~ 200mbar / 0 ~ 150mmHg	XGZP6859D 020KPG
0 ~ 40	0 ~ 400mbar / 0 ~ 300mmHg	XGZP6859D 040KPG
0 ~ 100	0 ~ 1bar / 0 ~ 14.5PSI	XGZP6859D 100KPG
0 ~ 200	0 ~ 2bar / 0 ~ 29PSI	XGZP6859D 200KPG
-100 ~ 0	-1 ~ 0bar / -14.5 ~ 0PSI	XGZP6859D 100KPGN
-30 ~ 0	-300 ~ 0mbar / -4.35 ~ 0PSI	XGZP6859D 030KPGN
-20 ~ 0	-200 ~ 0mbar / -2.9 ~ 0PSI	XGZP6859D 020KPGN
-1 ~ 1	-10 ~ 10mbar / -100 ~ 100mmH ₂ O	XGZP6859D 001KPGPN
-2.5 ~ 2.5	-25 ~ 25mbar / -250 ~ 250mmH ₂ O	XGZP6859D 025HPGPN
-5 ~ 5	-50 ~ 50mbar / -500 ~ 500mmH ₂ O	XGZP6859D 005KPGPN
-40 ~ 40	-400 ~ 400mbar / -300 ~ 300mmHg	XGZP6859D 040KPGPN
-100 ~ 100	-1 ~ 1bar / -14.5 ~ 14.5PSI	XGZP6859D 100KPGPN
-100 ~ 200	-1 ~ 2bar / -14.5 ~ 29PSI	XGZP6859D 200KPGPN
 Please consult CFSensor whether required pressure range is under normal production before place order.		

I2C INTERFACE

I2C bus uses SCL and SDA as signal lines. Both lines are connected to VDD externally via pull-up resistors (Typ value: **4.7kΩ**) so that they are pulled high when the bus is free. I2C device factory setting slave address: **0X6D**.

The master device can communicate with the product using commands in the following format:

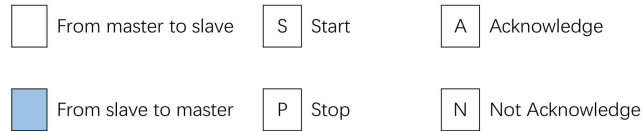

Write One Byte To One Register



Read One Byte From One Register

ELECTRICAL SPEC. OF I2C INTERFACE PIN

Symbol	Parameter	Condition	Min	Max	Unit
f_{scl}	Clock frequency			400	KHz
t_{LOW}	SCL low pulse		1.3		US
t_{HIGH}	SCL high pulse		0.6		US
t_{SUDAT}	SDA setup time		0.1		US
t_{HDDAT}	SDA hold time		0.0		US
t_{SUSTA}	Setup Time for a repeated start		0.6		US
t_{HDSTA}	Hold time for a start condition		0.6		US
t_{SUSTO}	Setup Time for a stop condition		0.6		US
t_{BUF}	Time before a new transmission		1.3		US

I2C TIME DIAGRAM

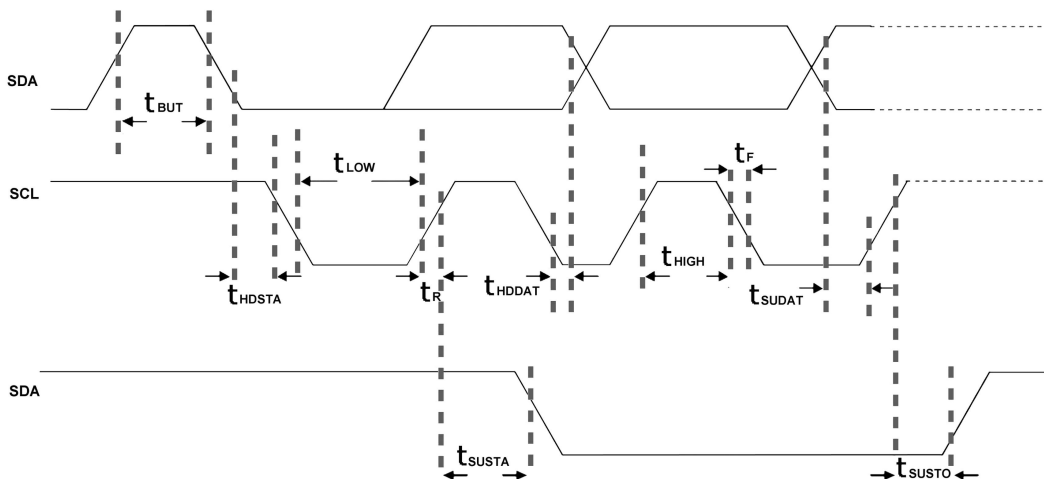

The I2C interface protocol has special bus signal conditions. Start (S), stop (P) and binary data conditions are shown below. At start condition, SCL is high and SDA has a falling edge. Then the slave address is sent. After the 7 address bits, the direction control bit R/W selects the read or write operation. When a slave device recognizes that it is being addressed, it should acknowledge by pulling SDA low in the ninth SCL (ACK) cycle.

At stop condition, SCL is also high, but SDA has a rising edge. Data must be held stable at SDA when SCL is high. Data can change value at SDA only when SCL is low.

I2C PROTOCOL

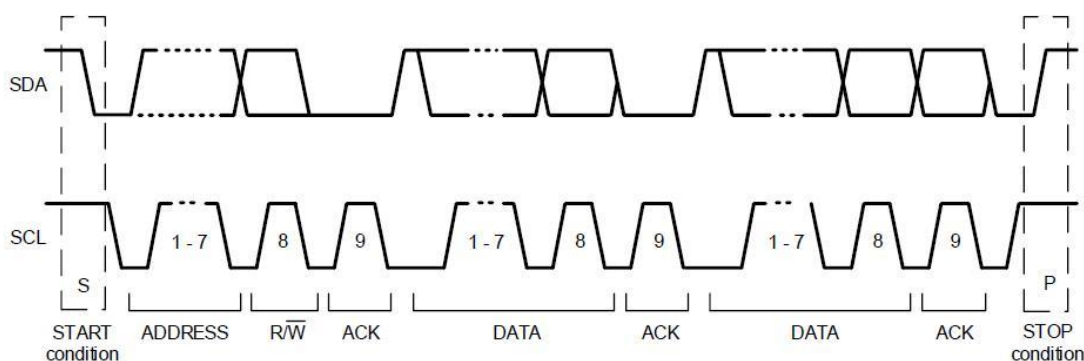

REGISTER DESC.

Addr.	Desc.	R/W	Bit7	Bit6	Bit5	Bit4	Bit3	Bit2	Bit1	Bit0	Default
0x06	DATA_MSB	R	Pressure Data out<23:16>								0x00
0x07	DATA_CSB	R	Pressure Data out<15:8>								0x00
0x08	DATA_LSB	R	Pressure Data out<7:0>								0x00
0x09	TEMP_MSB	R	Temp Data out<15:8>								0x00
0x0A	TEMP_LSB	R	Temp Data out<7:0>								0x00
0x30	CMD	RW	Sleep_time<7:4>				Sco	Measurement_ctrl<2:0>			0x00
0xA5	Sys_config	RW	Aout_config<7:4>				LDO_config	Unipolar	Data_out_control	Diag_on	OTP
0xA6	P_config	RW		Input Swap	Gain_P<5:3>			OSR_P<2:0>			OTP

Reg0x06-Reg0x0A :

Pressure ADC data Register(Reg0x06-Reg0x08); Temperature ADC data Register(Reg0x09-Reg0x0A)

Reg0x30 :

Measurement Command Register

Sleep_time<7:4>: 0000:0ms; 0001:62.5ms; 0010:125ms ;... 1111: 1s, only active during sleep mode conversion.

Sco: 1, Start of conversion, automatically come back to 0 after conversion ends (except sleep mode conversion).

Measurement_control<2:0>:

010: indicate the combined conversion (namely a temperature conversion followed by a pressure-signal conversion).

011: indicate a sleep mode conversion (periodically perform a combined conversion with an interval time of 'sleep_time'),

Reg0xA5(configured at factory)

Aout_config<7:4>: Analog output setting(recommending reserve default value)

LDO_config: 0: set with 1.8V; 1: setwith 3.6V.

Unipolar: 0: ADC output in bipolar format(signed binary), 1: ADC output in unipolar format. (Unsigned binary, Only take effect when 'raw_data_on' = 1)

Raw_data_on: 0: output calibrated data(as default value), 1: output ADC raw data.

Diag_on: 1, Enable diagnosis function(default).

Reg0xA6(configured at factory)

Input Swap: Swap VINP and VINN inside the ASIC

Gain_<5:3>: set the gain of the sensor signal conversion channel. 000: gain=1, 001: gain=2, 010: gain=4, 011: gain=8, 100: gain=16, 101: gain=32, 110: gain=64, 111: gain=128.

OSR_P<2:0>: set the over sampling ratio of the sensor signal conversion channel. 000:1024X, 001:2048X, 010:4096X, 011:8192X, 100:256X, 101:512X, 110:16384X, 111:32768X.

READ OPERATION

As the following instruction sequences for reading data:

(Only for combined conversion (namely a temperature conversion immediately followed by a pressure-signal conversion))

1. Send instructions 0x0A to 0x30 register for one temperature acquisition, one pressure data acquisition.
2. Read the 0x30 register address. If Sco bit is 0, signify the acquisition end, the data can be read.
(Or, Hold 20mS and then skip this step to read data directly)
3. Read 0x06, 0x07, 0x08 register address data to form a 24-bit AD value (pressure data AD value); Read 0x09, 0x0A register address data to form a 16-bit AD value (temperature data AD value)

Read Pressure

The total pressure output value which include 0x06, 0x07 and 0x08 registers are 24 bits. The highest bit is the symbol bit, and the value is "1", it represents "negative pressure"; The symbol digit value is "0", it represents "positive pressure".

Pressure_ADC value: = (Pressure 3rd Byte [23:16] x 65536+Pressure 2nd Byte [15:8] x 256 + Pressure1st Byte [7:0])

Note: 1 Pressure 3rd Byte [23:16] is the hexadecimal value read out by REG0x06 and need converte into decimal value;

2 Pressure 2nd Byte [15:8] is the hexadecimal value read out by REG0x07 and need converte into decimal value;

3 Pressure 1st Byte [7:0] is the hexadecimal value read out by REG0x08 and need converte into decimal value.

For Pressure conversion formula are as follows:

The highest bit is "0", which means positive pressure

Pressure = Pressure_ ADC /k;

The highest bit is "1", which means negative pressure

Pressure=(pressure_ADC-2²⁴)/k;

Note:

1. the unit is Pa (default). If need to display other units, fill the corresponding coefficient in the conversion formula for conversion;

2. the K value is selected according to the postive pressure value only, like -100 ~ 100kPa,the K value is 64.

Pressure range(kpa)	K(value)
131<P≤260	32
65<P≤131	64
32<P≤65	128
16<P≤32	256
8<P≤16	512
4<P≤8	1024
2≤P≤4	2048
1≤P<2	4096
P<1	8192

Read Temperature

The bits of temperature output values in the 0x09 and 0x0A registers are 16 bits, the highest bit is the symbol bit.

The symbol digit value is "1" when it represents "negative", and the symbol digit value is "0" when it represents "positive".

Supposing if the decimal values of REG0x09 and REG0x0A readout are X, Y,

For Temperature ADC value and conversion formula are as:

Temperature AD value: $N = X * 256 + Y$

If $n < 2^{15}$, Temperature is positive value, actual temperature $T = N / 256$; (°C).

If $n > 2^{15}$, Temperature is negative value, actual temperature value = $(N - 2^{16}) / 256$; (°C)

PACKING INFORMATION

Plastic Tube(unit:mm)

Standard Quantity/Tube: 70 pcs

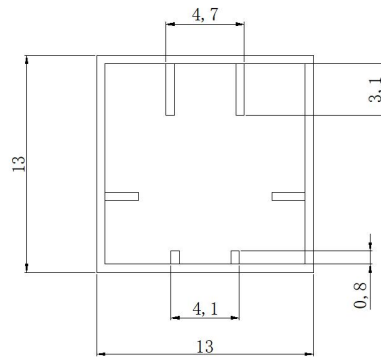

Side view

White Plug

Mark Direction

Blue Plug

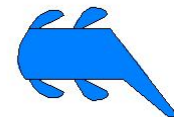
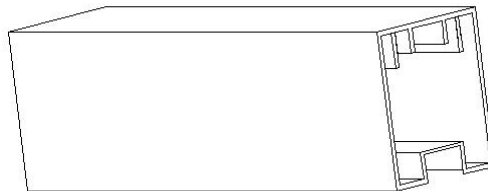
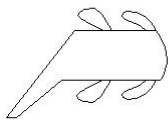

(520mm x 13mm x 13mm, 70PCS)

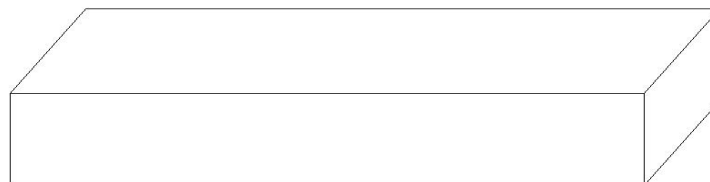

(CARTON: 530mm x 145mm x 53mm, 2800PCS)

Note: The packing size may be not quite same with above for other different quantity.

OVERALL NOTES

Unless otherwise specified, following notes are general attention or presentation for all products from CFSensor.

Mounting

The following steps is for transmitting the air pressure to sensor after sensor soldering on PCB.

- ▼ For some sensors that come with inlet tube, select the flexible pipe to suit the pressure inlet that is firm enough to prevent the pressure leaks.
- ▼ Atmosphere hole (for Gauge type sensors) and Inlet pipe/hole can't be blocked with gel or glue etc..
- ▼ Avoiding excessive external force operation

Soldering

Due to its small size, the thermal capacity of the pressure sensor is low. Therefore, take steps to minimize the effects of external heat. Damage and changes to characteristics may occur due to heat deformation. Use a non-corrosive resin type of flux. Since the pressure sensor is exposed to the atmosphere, do not allow flux to enter inside.

- ▼ Manual soldering
 - Raise the temperature of the soldering tip between 260 and 300°C/500 and 572°F (30 W) and solder within 5 seconds.
 - The sensor output may vary if the load is applied on the terminal during soldering.
 - Keep the soldering tip clean.
- ▼ DIP soldering (DIP Terminal)
 - Keep the temperature of the DIP solder tank below 260°C/500 and solder within 5 seconds.
 - To avoid heat deformation, do not perform DIP soldering when mounting on the PCB which has a small thermal capacity.
- ▼ Reflow soldering (SMD Terminal)
 - The recommended reflow temperature profile conditions are given below.

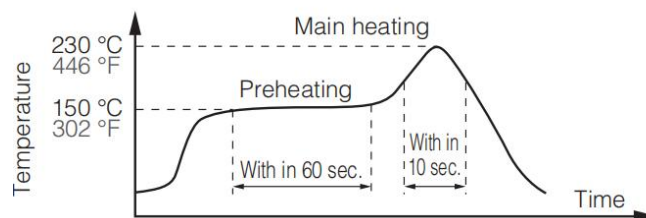

- Self alignment may not always work as expected, therefore, please carefully note the position of the terminals and pattern.
- The temperature of the profile is assumed to be a value measured with the printed circuit board of the terminal neighborhood.
- Please evaluate solderability under the actual mounting conditions since welding and deformation of the pressure inlet port may occur due to heat stress depending on equipments or conditions.
- ▼ Rework soldering
 - Complete rework at a time.
 - Use a flattened soldering tip when performing rework on the solder bridge. Do not add the flux.
 - Keep the soldering tip below the temperature described in the specifications.
- ▼ Avoid drop and rough handling as excessive force may deform the terminal and damage soldering characteristics.
- ▼ Keep the circuit board warpage within 0.05 mm of the full width of the sensor.
- ▼ After soldering, do not apply stress on the soldered part when cutting or bending the circuit board.
- ▼ Prevent human hands or metal pieces from contacting with the sensor terminal. Such contact may cause anomalous outlets as the terminal is exposed to the atmosphere.

▼ After soldering, prevent chemical agents from adhering to the sensor when applying coating to avoid insulation deterioration of the circuit board.

Connecting

▼ Correctly wire as in the connection diagram. Reverse connection may damage the product and degrade the performance.

▼ Do not use idle terminals(N/C) to prevent damages to the sensor.

Cleaning

▼ Since the pressure sensor is exposed to the atmosphere, do not allow cleaning fluid to enter inside from atmosphere hole (for Gauge type sensors) and inlet pipe.

▼ Avoid ultrasonic cleaning since this may cause breaks or disconnections in the wiring.

Environment

▼ Please avoid using or storing the pressure sensor in a place exposed to corrosive gases (such as the gases given off by organic solvents, sulfurous acid gas, hydrogen sulfides, etc.) which will adversely affect the performance of the pressure sensor chip.

▼ Since this pressure sensor itself does not have a water-proof construction(even available media can be liquid), please do not use the sensor in a location where it may be sprayed with water, etc.

▼ Avoid using the pressure sensors in an environment where condensation may form. Furthermore, its output may fluctuate if any moisture adhering to it freezes.

▼ The pressure sensor is constructed in such a way that its output will fluctuate when it is exposed to light. Especially when pressure is to be applied by means of a transparent tube, take steps to prevent the pressure sensor chip from being exposed to light.

▼ Avoid using pressure sensor where it will be susceptible to ultrasonic or other high-frequency vibration.

▼ Keeping the sensors sealed in static shielding bags with an oxygen-free condition and use the sensor as soon as possible once unfold the package, because the sensors' PINs may be oxidated a bit under atmosphere environment(slight oxidation wouldn't affect soldering and performance)

More Precautions

▼ That using the wrong pressure range or mounting method may result in accidents.

▼ The only direct pressure medium you can use is non-corrosive gas or air as illuminated above(Note: some sensors are compatible with liquid media). The use of other media, in particular, corrosive gases and liquid (organic solvent based, sulfurous acid based, and hydrogen sulfide based, etc.) or contains foreign substances will cause malfunction and damage. Please do not use them and check with CFSensor.

▼ The pressure sensor is positioned inside the pressure inlet. Never poke wires or other foreign matter through the pressure inlet since they may damage the sensor or block the inlet. Avoid use when the atmospheric pressure inlet(only for Gauge type pressure sensor) is blocked.

▼ Use an operating pressure which is within the rated pressure range. Using a pressure beyond this range may cause damage.

▼ Since static charge can damage the pressure sensor, bear in mind the following handling precautions.

⊙ When storing the pressure sensor, use a conductive material to short the pins or wrap the entire sensor in aluminum foil. Common plastic containers should not be used to store or transport the sensor since they readily become charged.

⊙ When using the pressure sensor, all the charged articles on the bench surface and the work personnel should be grounded so that any ambient static will be safely discharged.

▼ Based on the pressure involved, give due consideration to the securing of the pressure sensor.

【 SAFETY NOTES 】

Using these sensors products may malfunction due to external interference and surges, therefore, please confirm the performance and quality in actual use. Just in case, please make a safety design on the device (fuse, circuit breaker, such as the installation of protection circuits, multiple devices, etc.), so it would not harm life, body, property, etc even a malfunction occurs. To prevent injuries and accidents, please be sure to observe the following items:

- The driving current and voltage should be used below the rated value.
- Please follow the terminal connection diagram for wiring. Especially for the reverse connection of the power supply, it will cause an accident due to circuit damage such as heat, smoke, fire, etc.
- In order to ensure safety, especially for important uses, please be sure to consider double safety circuit configuration.
- Do not apply pressure above the maximum applied pressure. In addition, please be careful not to mix foreign matter into the pressure medium. Otherwise, the sensor will be discarded, or the media will blow out and cause an accident.
- Be careful when fixing the product and connecting the pressure inlet. Otherwise, accidents may occur due to sensor scattering and the blowing out of the media.
- If the sensor come with sharp PIN, please be careful not to hurt your body when using it.

【 WARRANTY 】

The information in this sheet has been carefully reviewed and is believed to be accurate; however, no responsibility is assumed for inaccuracies. Furthermore, this information does not convey to the purchaser of such devices any license under the patent rights to the manufacturer. CFSensor reserves the right to make changes without further notice to any product herein. CFSensor makes no warranty, representation or guarantee regarding the suitability of its product for any particular purpose, nor does CFSensor assume any liability arising out of the application or use of any product or circuit and specifically disclaims any and all liability, including without limitation consequential or incidental damages. Typical parameters can and do vary in different applications. All operating parameters must be validated for each customer application by customer's technical experts. CFSensor does not convey any license under its patent rights nor the rights of others.

【 CONTACT 】

CFSensor

22F/14Bldg High-Tech Park High-Tech Area Wuhu P.R.C.241000

Tel/Fax:+86 18226771331 Email:INFO@CFSensor.com

North America || Europe || Southeast Asia || Middle East || Latin America

READ CODE(C51 Example)

```
#include <reg52.h>
#include <math.h>
#define DELAY_TIME 600
#define TRUE 1
#define FALSE 0
#define uchar unsigned char
#define uint unsigned int

//----define IIC SCL, SDA port----
sbit SCL = P1 ^ 7;
sbit SDA = P1 ^ 6;

//----delay time_us----
void DELAY(uint t)
{
    while (t != 0)
        t--;
}

//----IIC START CONDITION----
void I2C_Start(void)
{
    SDA = 1; //SDA output high
    DELAY(DELAY_TIME);
    SCL = 1;
    DELAY(DELAY_TIME); //SCL output high
    SDA = 0;
    DELAY(DELAY_TIME);
    SCL = 0;
    DELAY(DELAY_TIME);
}

//----IIC STOP CONDITION----
void I2C_Stop(void)
{
    SDA = 0; //SDA OUTPUT LOW
    DELAY(DELAY_TIME);
    SCL = 1;
    DELAY(DELAY_TIME);
    SDA = 1;
```

```
    DELAY(DELAY_TIME);
    SCL = 0;    //SCL OUTPUT LOW
    DELAY(DELAY_TIME);
}

//----IIC SEND DATA "0"----
void SEND_0(void)
{
    SDA = 0;
    DELAY(DELAY_TIME);
    SCL = 1;
    DELAY(DELAY_TIME);
    SCL = 0;
    DELAY(DELAY_TIME);
}

//----IIC SEND DATA "1"----
void SEND_1(void)
{
    SDA = 1;
    DELAY(DELAY_TIME);
    SCL = 1;
    DELAY(DELAY_TIME);
    SCL = 0;
    DELAY(DELAY_TIME);
}

//----Check SLAVE's Acknowledge----
bit Check_Acknowledge(void)
{
    SDA = 1;
    DELAY(DELAY_TIME);
    SCL = 1;
    DELAY(DELAY_TIME / 2);
    F0 = SDA;
    DELAY(DELAY_TIME / 2);
    SCL = 0;
    DELAY(DELAY_TIME);
    if (F0 == 1)
        return FALSE;
    return TRUE;
}
```

```
//----Write One Byte of Data----  
void Writel2CByte(uchar b) reentrant  
{  
    char i;  
    for (i = 0; i < 8; i++)  
        if ((b << i) & 0x80)  
            SEND_1();  
        else  
            SEND_0();  
}
```

```
//----Read One Byte of Data----  
uchar Readl2CByte(void) reentrant  
{  
    char b = 0, i;  
    for (i = 0; i < 8; i++)  
    {  
        SDA = 1;  
        DELAY(DELAY_TIME);  
        SCL = 1;  
        DELAY(DELAY_TIME);  
        F0 = SDA;  
        DELAY(DELAY_TIME);  
        SCL = 0;  
        if (F0 == 1)  
        {  
            b = b << 1;  
            b = b | 0x01;  
        }  
        else  
            b = b << 1;  
    }  
    return b;  
}
```

```
//----write One Byte of Data,Data from MASTER to the SLAVER----  
void Write_One_Byte(uchar addr, uchar thedata) //Write "thedata" to the SLAVER's address of "addr"  
{  
    bit acktemp = 1;  
    I2C_Start(); //IIC START  
    Writel2CByte(0x6D << 1 + 0); //IIC WRITE operation, SLAVER address bit: 0x6D
```

```
    acktemp = Check_Acknowledge();    //check the SLAVER
    Writel2CByte(addr);                //address
    acktemp = Check_Acknowledge();
    Writel2CByte(thedata);            //thedata
    acktemp = Check_Acknowledge();
    I2C_Stop(); //IIC STOP
}

//----Read One Byte of Data,Data from SLAVER to the MASTER----
uchar Read_One_Byte(uchar addr)
{
    bit acktemp = 1;
    uchar mydata;

    I2C_Start();
    Writel2CByte(0x6D << 1 + 0);    //IIC WRITE operation, SLAVER address bit: 0x6D
    acktemp = Check_Acknowledge();
    Writel2CByte(addr);
    acktemp = Check_Acknowledge();
    I2C_Start();
    Writel2CByte(0x6D << 1 + 1);    //IIC READ operation, SLAVER address bit: 0x6D
    acktemp = Check_Acknowledge();
    mydata = ReadI2CByte();
    I2C_Stop();
    return mydata;
}

//----Delay_ms----
void Delay_xms(uint x)
{
    uint i, j;
    for (i = 0; i < x; i++)
        for (j = 0; j < 112; j++)
            ;
}

//----The main function----
void main(void)
{
    uchar pressure_H, pressure_M, pressure_L, temperature_H, temperature_L;
    //temporary variables of pressure and temperature
    long int pressure_adc, temperature_adc;
```



```
//The value of pressure and temperature converted by the sensor's ADC
long float pressure, temperature;
//The calibrated value of pressure and temperature
Delay_xms(1000);    //delay 1000ms

while (1)
{
    Write_One_Byte(0x30, 0x0A);
    //indicate a combined conversion (once temperature conversion immediately followed by once sensor signal
    conversion)
    //more measurement method, check Register 0x30
    while ((Read_One_Byte(0x30) & 0x08) > 0); //Judge whether Data collection is over, if above action has no response,
delete that command and execute this command as: Delay_xms(20);

    pressure_H = Read_One_Byte(0x06);
    pressure_M = Read_One_Byte(0x07);
    pressure_L = Read_One_Byte(0x08);
    // Read ADC output Data of Pressure
    pressure_adc = pressure_H * 65536 + pressure_M * 256 + pressure_L;
    //Compute the value of pressure converted by ADC

    if (pressure_adc > 8388608)
        pressure = (pressure_adc - 16777216) / K; //unit is Pa, select appropriate K value according to pressure range.
    else
        pressure = pressure_adc / K; //unit is Pa, select appropriate K value according to pressure range.
    //The conversion formula of calibrated pressure, its unit is Pa

    temperature_H = Read_One_Byte(0x09);
    temperature_L = Read_One_Byte(0x0A);
    //Read ADC output data of temperature
    temperature_adc = temperature_H * 256 + temperature_L;
    //Compute the value of temperature converted by ADC
    temperature = (temperature_adc - 65536) / 256;    //unit is °C
    else
        temperature = temperature_adc / 256;    //unit is °C
    //The conversion formula of calibrated temperature, its unit is Centigrade

    Delay_xms(100); //delay 100ms
}
}
```