

XI5050(4W)

Series



Introduction

The 5050 package is a lighting grade high power LED. It is a compact package with high lumens and efficiency and is suitable for many lighting applications.

Features

- ◆ Top view white LED
- ◆ Moisture Sensitivity Level: 3
- ◆ High flux output
- ◆ White package
- ◆ Wide viewing angle
- ◆ Pb-free
- ◆ RoHS compliant
- ◆ Typical viewing angle: 120°
- ◆ ANSI binning
- ◆ Reliability testing conforms to IESNA LM80 Lumen maintenance test method

Applications

- ◆ Omni-directional Bulbs
- ◆ Linear Lighting
- ◆ Panel Light

Table of Contents

Product Nomenclature.....	3
Absolute Maximum Ratings.....	4
PN of the XI5050 series: Warm White LEDs	5
Product Binning	6
Forward Voltage Bins.....	13
Mechanical Dimension	14
Pad Configuration	14
Reflow Soldering Characteristics.....	16
Wavelength Characteristics	17
Typical Electrical Characteristics	17
Typical Relative Luminous Flux V.S. Forward Current.....	18
Typical Wavelength & Color Shift Characteristics	18
Typical Radiation Patterns	19
Emitter Tape Packaging.....	20
Emitter Reel Packaging	21
Product Labeling	21
Reliability Data.....	22
Storage Conditions	23
Revision History.....	24

EVERLIGHT

Product Nomenclature

The product name is designated as below:

XI5050 – ABCDEFG – HIJKL – MNOP

Designation:

AB = color ^[1]

CD = color bin or CCT bin ^[1]

E = Steps Mcadams bin

FG = min. luminous flux (lm) or radiation power (mW) performance

HI = forward voltage bin

J = internal code

KL = power consumption^[2]

M = internal code

N = Dam

O = internal code

P = packaging type^[3]

Notes

1. Table of color offerings:

Symbol	Color	CCT range	Color Rendering Index
GT	Cool-White	4745~7050K	>65
KT	Cool-White	4745~7050K	>80
PT	Cool-White	4745~7050K	>90
HT	Cool-White	4745~7050K	>93
LM	Warm-White	2580~3710K	>70
	Neutral-White	3710K-4745K	
KM	Warm White	2580~3710K	>80
	Neutral-White	3710K-4745K	
PM	Warm White	2580~3710K	>90
	Neutral-White	3710K-4745K	
HM	Warm White	2580~3710K	>93
	Neutral-White	3710K-4745K	

2. Table of power consumptions:

Symbol	Description
04	4W

3. Table of packaging types:

Symbol	Description
T	Tapping

Absolute Maximum Ratings

Parameter	Symbol	Ratings	Unit
Max. DC Forward Current (mA)	IF	240	mA
Max. Peak Pulse Current (mA)	IPulse	260 _[1]	mA
Power Dissipation	Pd	4	W
Thermal Resistance	R _{th}	10	°C/W
Operating Temperature	Topr	-40 ~ +85	°C
Storage Temperature	Tstg	-40 ~ +100	°C
Junction temperature	Tj	125	°C
Max. Soldering Temperature	T _{Sol}	260	°C

Notes:

1. Duty cycle = 1/10@1KHZ

EVERLIGHT

PN of the XI5050 series: White LED

Order Code of XI 5050	Min. Luminous Flux (lm)	Typ. Luminous Flux (lm)	CCT (K) Wavelength (nm)	Forward Voltage (V)	Forward Current (mA)	CRI (typ.)
XI5050-KM277K9-20104-000P	425	472	2580-2870	18-22	200	80
XI5050-KM307N1-20104-000P	450	485	2870-3220	18-22	200	80
XI5050-KM407N1-20104-000P	450	491	3710-4260	18-22	200	80
XI5050-KT507N2-20104-000P	475	510	4745-5310	18-22	200	80
XI5050-KT577N2-20104-000P	475	512	5310-6020	18-22	200	80
XI5050-KT657N2-20104-000P	475	508	6020-7050	18-22	200	80

Notes:

1. Luminous flux measurement tolerance: $\pm 10\%$.
2. The data of luminous flux measured at thermal pad=25°C
3. Typical luminous flux or light output performance is operated within the condition guided by this datasheet
4. The CRI value is based on the Everlight testing instrument.
5. CRI measurement tolerance: ± 2 .

Product Binning
Luminous Flux Bins

Group	Bin	Minimum Photometric Flux (lm)	Maximum Photometric Flux (lm)
J	1	100	110
	2	110	120
	3	120	130
	4	130	140
	5	140	150
	6	150	160
	7	160	180
	8	180	200
	9	200	225
K	1	225	250
	2	250	275
	3	275	300
	4	300	325
	5	325	350
	6	350	375
	7	375	400
	8	400	425
	9	425	450

Group	Bin	Minimum Photometric Flux (lm)	Maximum Photometric Flux (lm)
N	1	450	475
	2	475	500
	3	500	550
	4	550	600
	5	600	650
	6	650	700
	7	700	750
	8	750	800
	9	800	900
P	1	900	1000
	2	1000	1100
	3	1100	1200
	4	1200	1350
	5	1350	1500
	6	1500	1650
	7	1650	1800
	8	1800	2000
	9	2000	2200

White Bin Structure

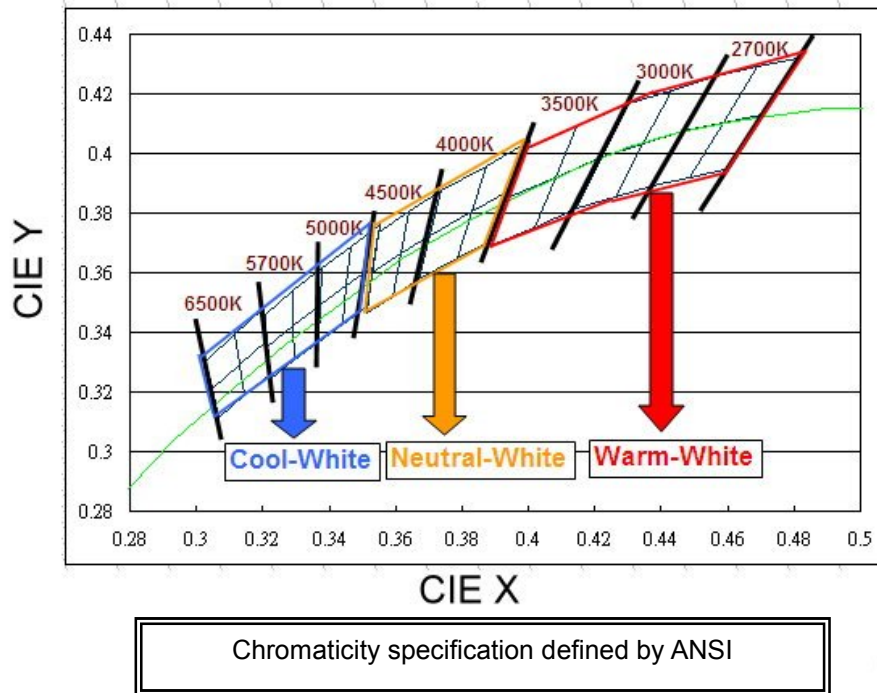

Notes:

1. The CCT range of Cool-White varies from 4745K to 7050K.
2. The CCT range of Neutral-White varies from 3710K to 4745K.
3. The CCT range of Warm-White varies from 2580K to 3710K
4. Color coordinates measurement allowance : ± 0.01
5. Color bins are defined at $I_F=500\text{mA}$ operation

Warm-White Bin Structure

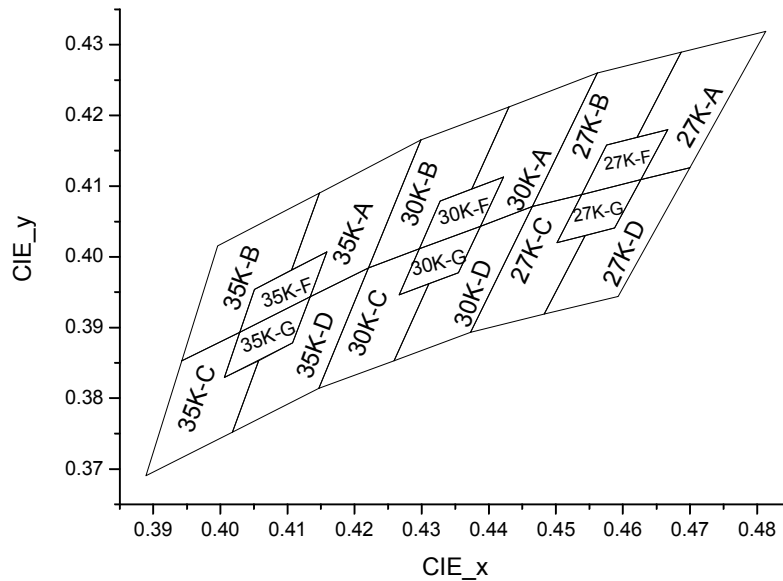

Warm-White Bin Coordinates

2700K

Bin	CIE X	CIE Y
27K-A	0.4813	0.4319
	0.4687	0.4289
	0.4621	0.4169
	0.4667	0.4180
	0.4627	0.4109
	0.4700	0.4126
Reference Range: 2580~2700K		

Bin	CIE X	CIE Y
27K-B	0.4687	0.4289
	0.4562	0.4260
	0.4465	0.4071
	0.4539	0.4088
	0.4576	0.4158
	0.4621	0.4169
Reference Range: 2700~2870K		

Bin	CIE X	CIE Y
27K-C	0.4465	0.4071
	0.4373	0.3893
	0.4483	0.3919
	0.4544	0.4030
	0.4502	0.4020
	0.4539	0.4088
Reference Range: 2700~2870K		

Bin	CIE X	CIE Y
27K-D	0.4700	0.4126
	0.4627	0.4109
	0.4588	0.4041
	0.4544	0.4030
	0.4483	0.3919
	0.4593	0.3944
Reference Range: 2580~2700K		

Bin	CIE X	CIE Y
27K-F	0.4667	0.4180
	0.4576	0.4158
	0.4539	0.4088
	0.4627	0.4109
Reference Range: 2680~2790K		

Bin	CIE X	CIE Y
27K-G	0.4627	0.4109
	0.4539	0.4088
	0.4502	0.4020
	0.4588	0.4041
Reference Range: 2680~2790K		

3000K

Bin	CIE X	CIE Y
30K-A	0.4562	0.4260
	0.4430	0.4212
	0.4375	0.4096
	0.4422	0.4113
	0.4388	0.4043
	0.4465	0.4071
Reference Range: 2870~3000K		

Bin	CIE X	CIE Y
30K-B	0.4430	0.4212
	0.4299	0.4165
	0.4221	0.3984
	0.4297	0.4011
	0.4328	0.4079
	0.4375	0.4096
Reference Range: 3000~3220K		

Bin	CIE X	CIE Y
30K-C	0.4221	0.3984
	0.4147	0.3814
	0.4259	0.3853
	0.4311	0.3962
	0.4267	0.3946
	0.4297	0.4011
Reference Range: 3000~3220K		

Bin	CIE X	CIE Y
30K-D	0.4465	0.4071
	0.4388	0.4043
	0.4355	0.3977
	0.4311	0.3962
	0.4259	0.3853
	0.4373	0.3893
Reference Range: 2870~3000K		

Bin	CIE X	CIE Y
30K-F	0.4422	0.4113
	0.4328	0.4079
	0.4297	0.4011
	0.4388	0.4043
Reference Range: 2960~3150K		

Bin	CIE X	CIE Y
30K-G	0.4388	0.4043
	0.4297	0.4011
	0.4267	0.3946
	0.4355	0.3977
Reference Range: 2960~3150K		

3500K

Bin	CIE X	CIE Y
35K-A	0.4299	0.4165
	0.4148	0.4090
	0.4106	0.3981
	0.4159	0.4007
	0.4134	0.3943
	0.4221	0.3984
Reference Range: 3220~3500K		

Bin	CIE X	CIE Y
35K-B	0.4148	0.4090
	0.3996	0.4015
	0.3943	0.3853
	0.4029	0.3893
	0.4051	0.3954
	0.4106	0.3981
Reference Range: 3500~3710K		

Bin	CIE X	CIE Y
35K-C	0.3943	0.3853
	0.3889	0.3690
	0.4018	0.3752
	0.4057	0.3853
	0.4006	0.3829
	0.4029	0.3893
Reference Range: 3500~3710K		

Bin	CIE X	CIE Y
35K-D	0.4221	0.3984
	0.4134	0.3943
	0.4108	0.3878
	0.4057	0.3853
	0.4018	0.3752
	0.4147	0.3814
Reference Range: 3220~3500K		

Bin	CIE X	CIE Y
35K-F	0.4159	0.4007
	0.4051	0.3954
	0.4029	0.3893
	0.4134	0.3943
Reference Range: 3370~3560K		

Bin	CIE X	CIE Y
35K-G	0.4134	0.3943
	0.4029	0.3893
	0.4006	0.3829
	0.4108	0.3878
Reference Range: 3370~3560K		

Note: Color coordinates measurement allowance : ± 0.01 .

Neutral-White Bin Structure

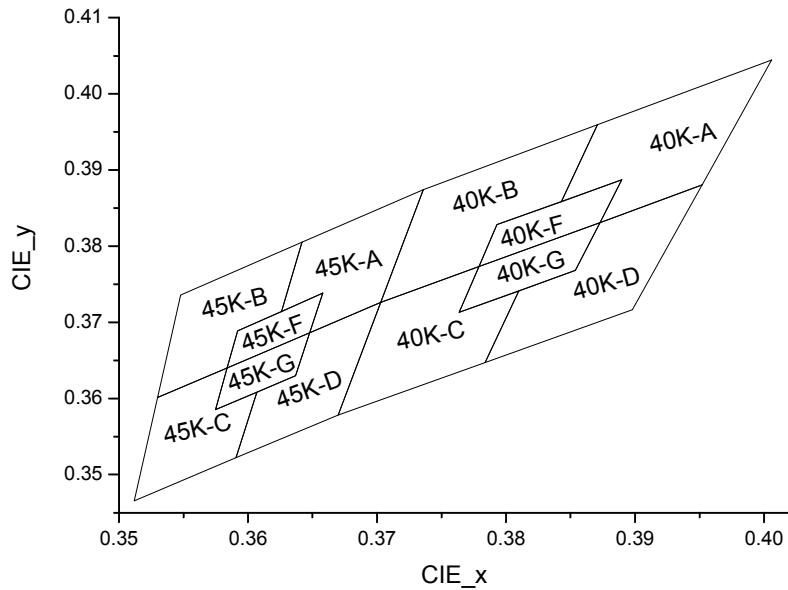

Neutral-White Bin Coordinates

4000K

Bin	CIE X	CIE Y
40K-A	0.4006	0.4044
	0.3871	0.3959
	0.3843	0.3858
	0.3890	0.3887
	0.3873	0.3831
	0.3952	0.3880
Reference Range: 3710~4000K		

Bin	CIE X	CIE Y
40K-B	0.3871	0.3959
	0.3736	0.3874
	0.3703	0.3726
	0.3779	0.3773
	0.3793	0.3828
	0.3843	0.3858
Reference Range: 4000~4260K		

Bin	CIE X	CIE Y
40K-C	0.3703	0.3726
	0.3670	0.3578
	0.3784	0.3647
	0.3810	0.3741
	0.3764	0.3713
	0.3779	0.3773
Reference Range: 4000~4260K		

Bin	CIE X	CIE Y
40K-D	0.3952	0.3880
	0.3873	0.3831
	0.3854	0.3768
	0.3810	0.3741
	0.3784	0.3647
	0.3898	0.3716
Reference Range: 3710~4000K		

Bin	CIE X	CIE Y
40K-F	0.3890	0.3887
	0.3793	0.3828
	0.3779	0.3773
	0.3873	0.3831
Reference Range: 3870~4080K		

Bin	CIE X	CIE Y
40K-G	0.3873	0.3831
	0.3779	0.3773
	0.3764	0.3713
	0.3854	0.3768
Reference Range: 3870~4080K		

Note: Color coordinates measurement allowance : ± 0.01 .

Cool-White Bin Structure

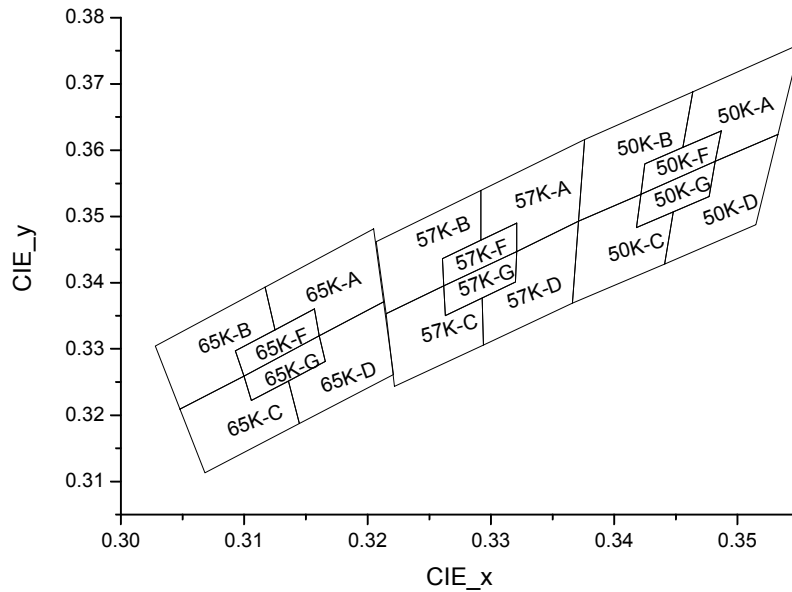

Cool-White Bin Coordinates

5000K

Bin	CIE X	CIE Y
50K-A	0.3551	0.3760
	0.3464	0.3688
	0.3456	0.3604
	0.3487	0.3629
	0.3482	0.3583
	0.3533	0.3624
Reference Range: 4745~5000K		

Bin	CIE X	CIE Y
50K-B	0.3464	0.3688
	0.3376	0.3616
	0.3371	0.3493
	0.3422	0.3533
	0.3425	0.3579
	0.3456	0.3604
Reference Range: 5000~5310K		

Bin	CIE X	CIE Y
50K-C	0.3371	0.3493
	0.3366	0.3369
	0.3441	0.3428
	0.3448	0.3507
	0.3418	0.3483
	0.3422	0.3533
Reference Range: 5000~5310K		

Bin	CIE X	CIE Y
50K-D	0.3533	0.3624
	0.3482	0.3583
	0.3477	0.3530
	0.3448	0.3507
	0.3441	0.3428
	0.3515	0.3487
Reference Range: 4745~5000K		

Bin	CIE X	CIE Y
50K-F	0.3487	0.3629
	0.3425	0.3579
	0.3422	0.3533
	0.3482	0.3583
Reference Range: 4900~5120K		

Bin	CIE X	CIE Y
50K-G	0.3482	0.3583
	0.3422	0.3533
	0.3418	0.3483
	0.3477	0.3530
Reference Range: 4900~5120K		

5700K

Bin	CIE X	CIE Y
57K-A	0.3376	0.3616
	0.3292	0.3539
	0.3292	0.3464
	0.3321	0.3490
	0.3321	0.3447
	0.3371	0.3493
Reference Range: 5310~5700K		

Bin	CIE X	CIE Y
57K-B	0.3292	0.3539
	0.3207	0.3462
	0.3215	0.3353
	0.3262	0.3395
	0.3261	0.3436
	0.3292	0.3464
Reference Range: 5700~6020K		

Bin	CIE X	CIE Y
57K-C	0.3215	0.3353
	0.3222	0.3243
	0.3294	0.3306
	0.3293	0.3377
	0.3263	0.3350
	0.3262	0.3395
Reference Range: 5700~6020K		

Bin	CIE X	CIE Y
57K-D	0.3371	0.3493
	0.3321	0.3447
	0.3320	0.3401
	0.3293	0.3377
	0.3294	0.3306
	0.3366	0.3369
Reference Range: 5310~5700K		

Bin	CIE X	CIE Y
57K-F	0.3321	0.3490
	0.3261	0.3436
	0.3262	0.3395
	0.3321	0.3447
Reference Range: 5510~5780K		

Bin	CIE X	CIE Y
57K-G	0.3321	0.3447
	0.3262	0.3395
	0.3263	0.3350
	0.3320	0.3401
Reference Range: 5510~5780K		

6500K

Bin	CIE X	CIE Y
65K-A	0.3205	0.3481
	0.3117	0.3393
	0.3125	0.3328
	0.3157	0.3360
	0.3161	0.3320
	0.3213	0.3371
Reference Range: 6020~6500K		

Bin	CIE X	CIE Y
65K-B	0.3117	0.3393
	0.3028	0.3304
	0.3048	0.3209
	0.3100	0.3259
	0.3093	0.3297
	0.3125	0.3328
Reference Range: 6500~7050K		

Bin	CIE X	CIE Y
65K-C	0.3048	0.3209
	0.3068	0.3113
	0.3145	0.3187
	0.3136	0.3251
	0.3106	0.3222
	0.3100	0.3259
Reference Range: 6500~7050K		

Bin	CIE X	CIE Y
65K-D	0.3213	0.3371
	0.3161	0.3320
	0.3166	0.3281
	0.3136	0.3251
	0.3145	0.3187
	0.3221	0.3261
Reference Range: 6020~6500K		

Bin	CIE X	CIE Y
65K-F	0.3157	0.3360
	0.3093	0.3297
	0.3100	0.3259
	0.3161	0.3320
Reference Range: 6300~6690K		

Bin	CIE X	CIE Y
65K-G	0.3161	0.3320
	0.3100	0.3259
	0.3106	0.3222
	0.3166	0.3281
Reference Range: 6300~6690K		

Note: Color coordinates measurement allowance : ± 0.01 .

Forward Voltage Bins

Bin	Minimum Forward Voltage (V)	Maximum Forward Voltage (V)
T1	18.0	19.0
T2	19.0	20.0
T3	20.0	21.0

Notes:

1. Forward voltage measurement tolerance: $\pm 0.1V$.
2. Forward voltage bins are defined at $I_f=200mA$ operation.

EVERLIGHT

Mechanical Dimension

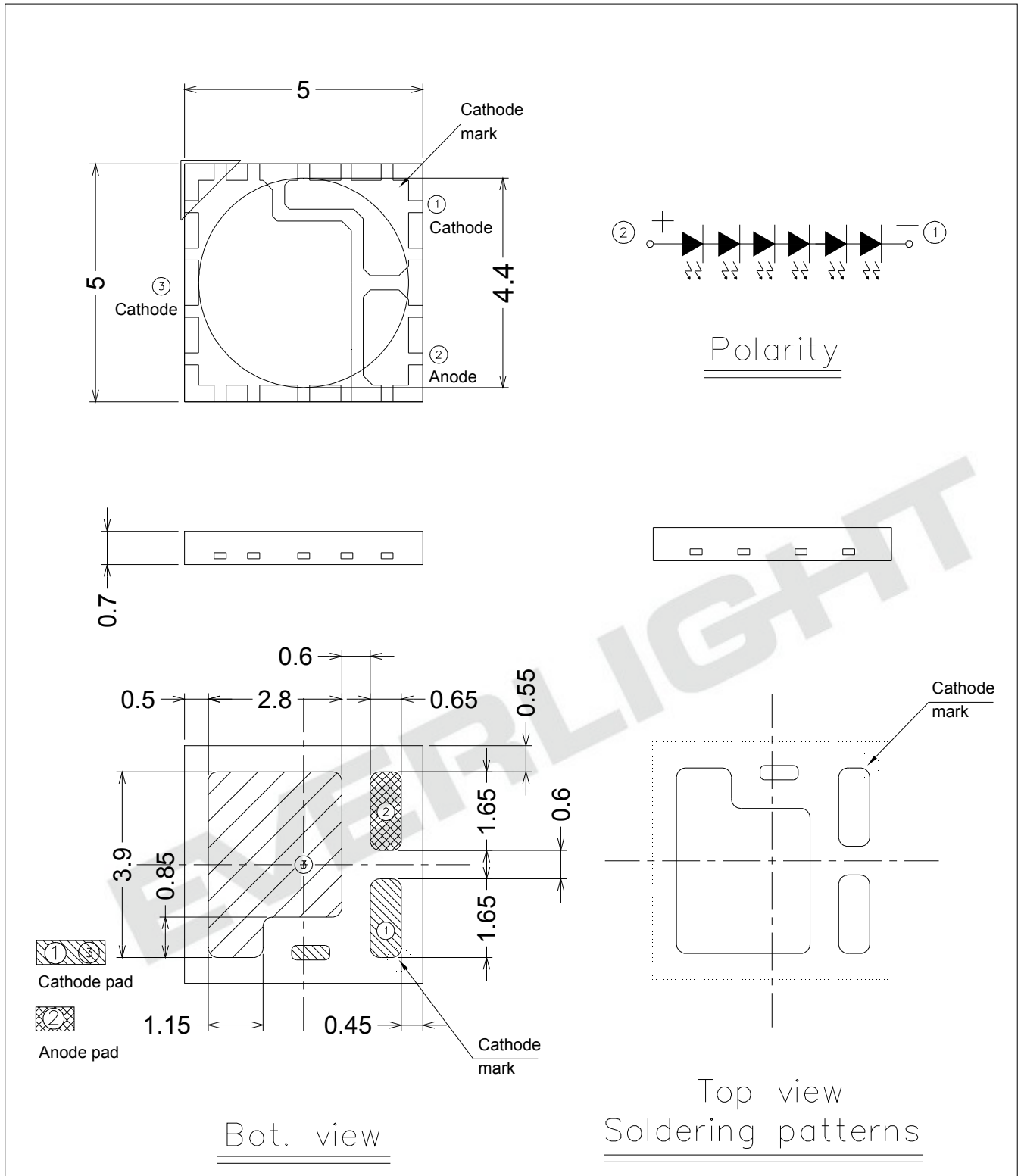

Notes:

1. Dimensions are in millimeters.
2. Tolerances unless mentioned are $\pm 0.15\text{mm}$.
3. The thermal pad is electrically unity from the Anode and contact pads.
4. Do not handle the device by the lens. Incorrect force applied to the lens may lead to the failure of devices.

Pad Configuration

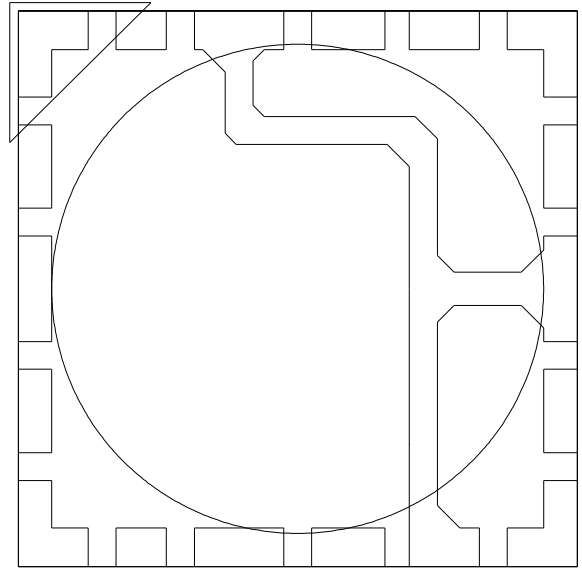
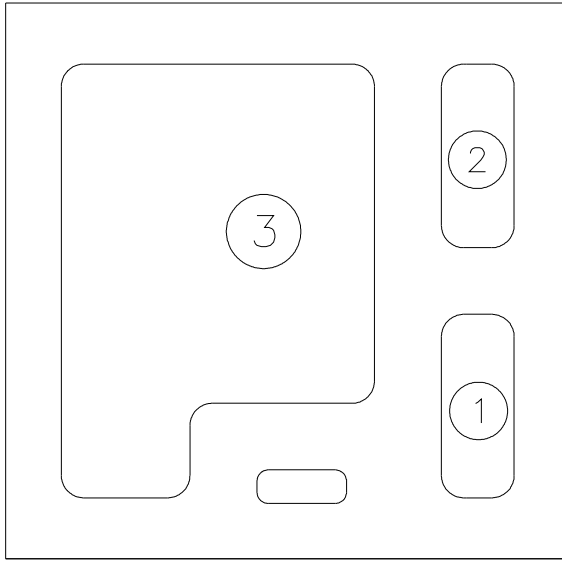

BOTTOM VIEW

TOP VIEW

PAD	FUNCTION
1	CATHODE
2	ANODE
3	CATHODE

Reflow Soldering Characteristics

For Reflow Process

- 5050 series are suitable for SMT processes.
- Curing of glue in oven must be according to standard operation flow processes.

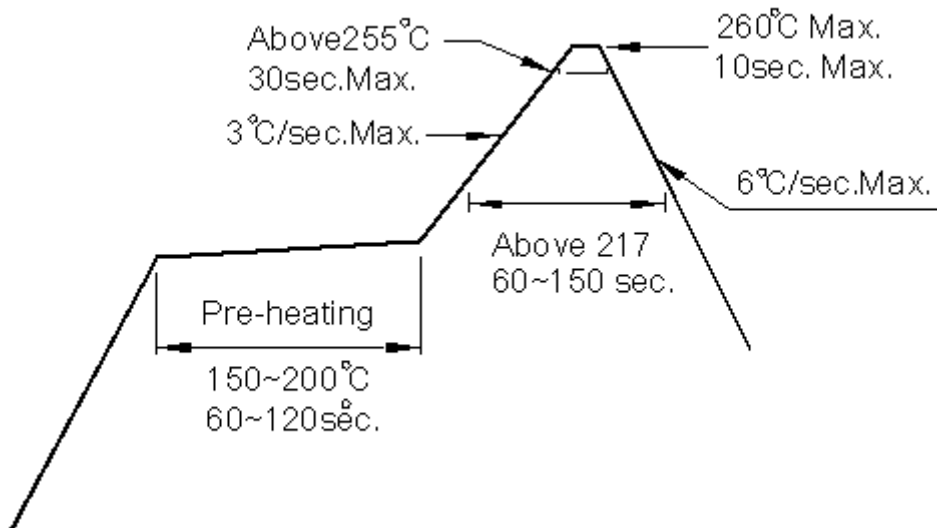

Profile Feature	Lead Free Assembly
Ramp-Up Rate	2-3 °C/S
Preheat Temperature	150-200 °C
Preheat Time (t _s)	60-120 S
Liquid Temperature (T _L)	217 °C
Time maintained above T _L	60-90 S
Peak Temperature (T _P)	260±5 °C
Peak Time (t _p)	Max 20 S
Ramp-Down Rate	3-5 °C/S

- Reflow soldering should not be done more than twice.
- In soldering process, stress on the LEDs during heating should be avoided.
- After soldering, do not bend the circuit board.

Wavelength Characteristics

Relative Spectral Distribution
@ Solder Pad Temperature = 25

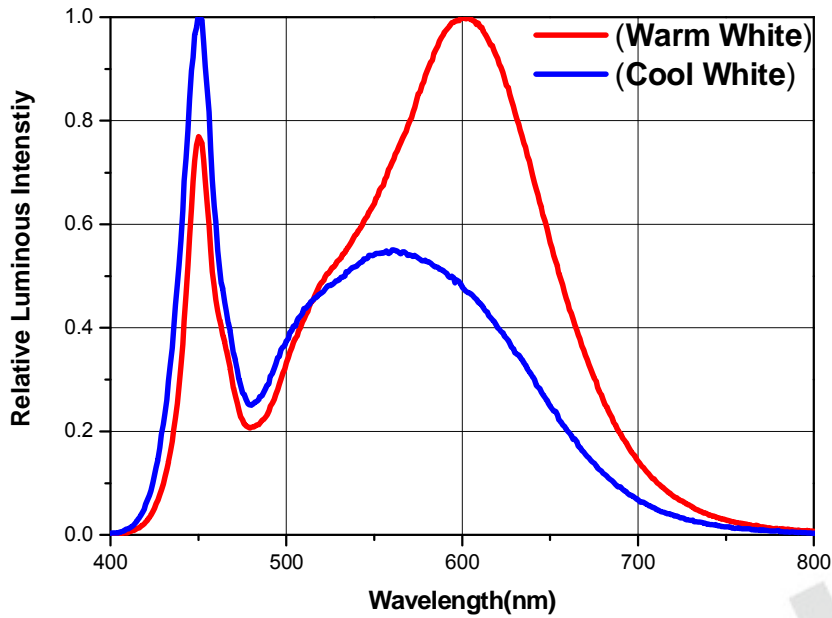

Typical Electrical Characteristics

@ Solder Pad Temperature = 25

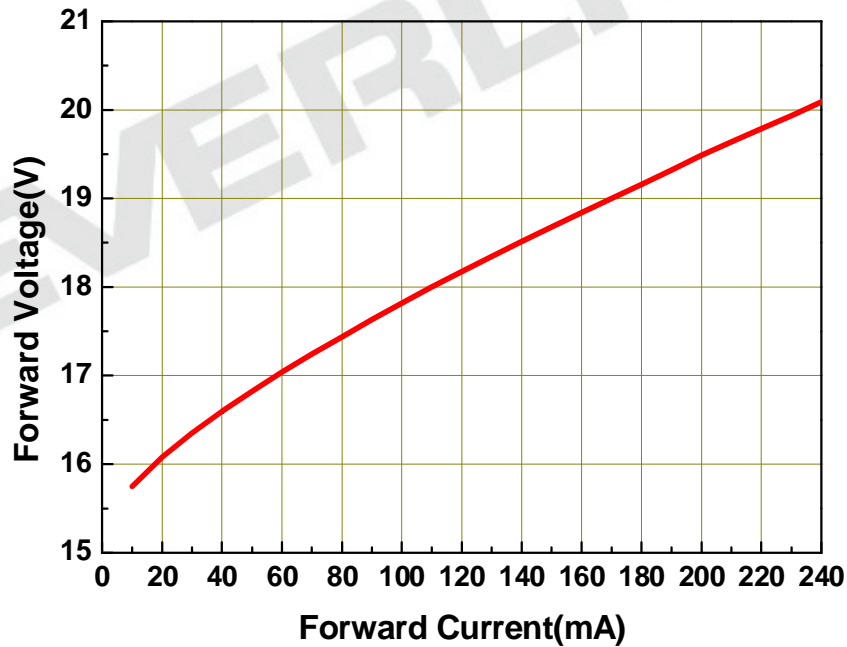

Typical Relative Luminous Flux V.S. Forward Current @ Solder Pad Temperature = 25

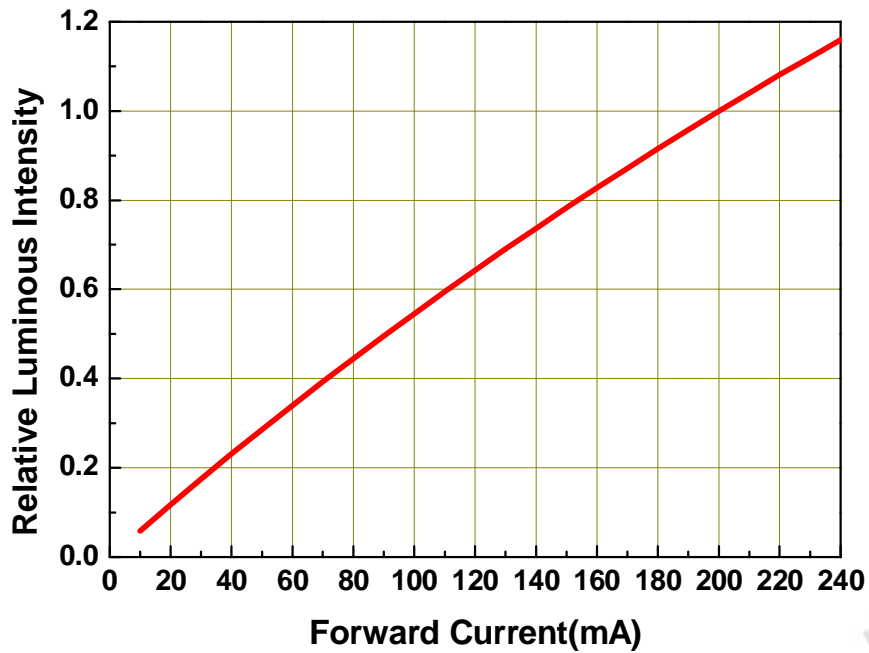

Typical Wavelength & Color Shift Characteristics V.S. Forward Current @ Solder Pad Temperature = 25

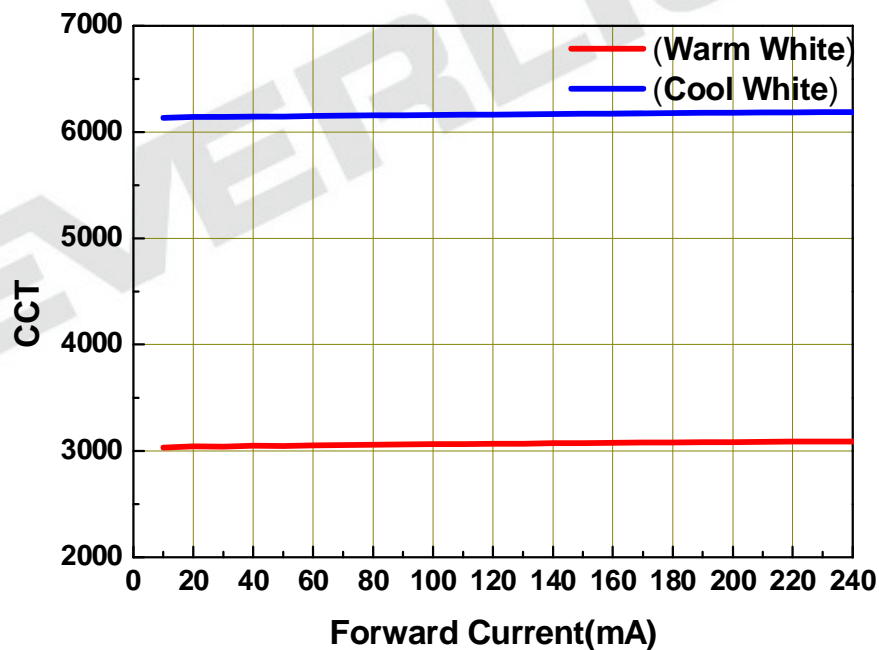

Forward Current Derating Curve @ Junction Temperature <125

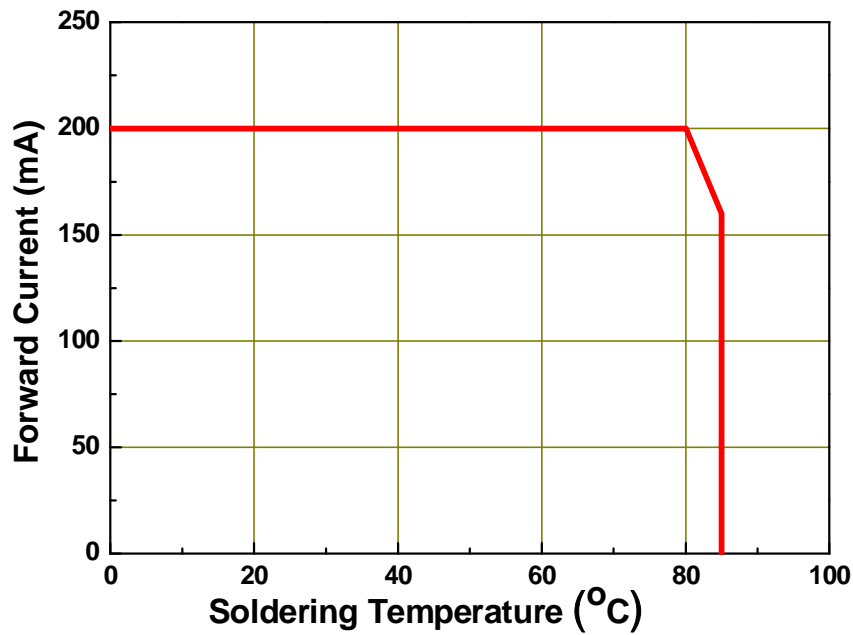

Typical Radiation Patterns 5050 series: Typical Diagram Characteristics of Radiation

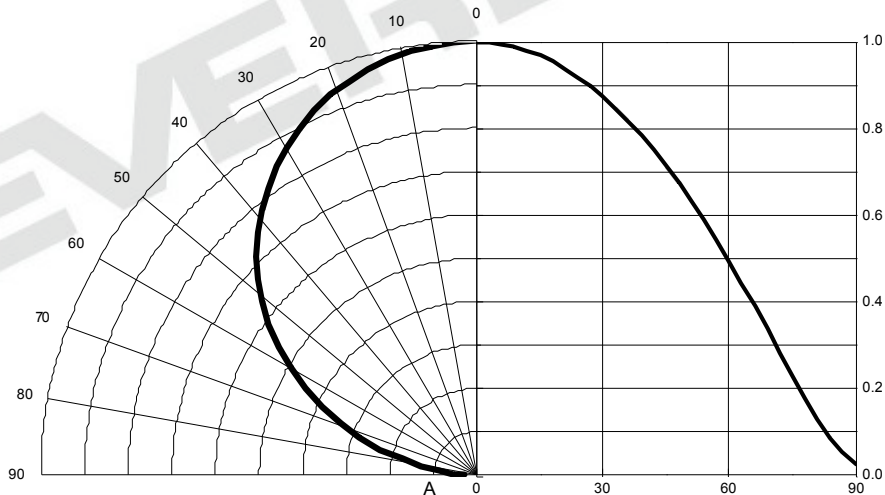

Notes:

1. $2\theta_{1/2}$ is the off axis angle from lamp centerline where the luminous intensity is 1/2 of the peak value.
2. View angle tolerance is $\pm 5^\circ$.

Emitter Tape Packaging

Carrier Tape Dimensions as the following:

Reel:1500pcs

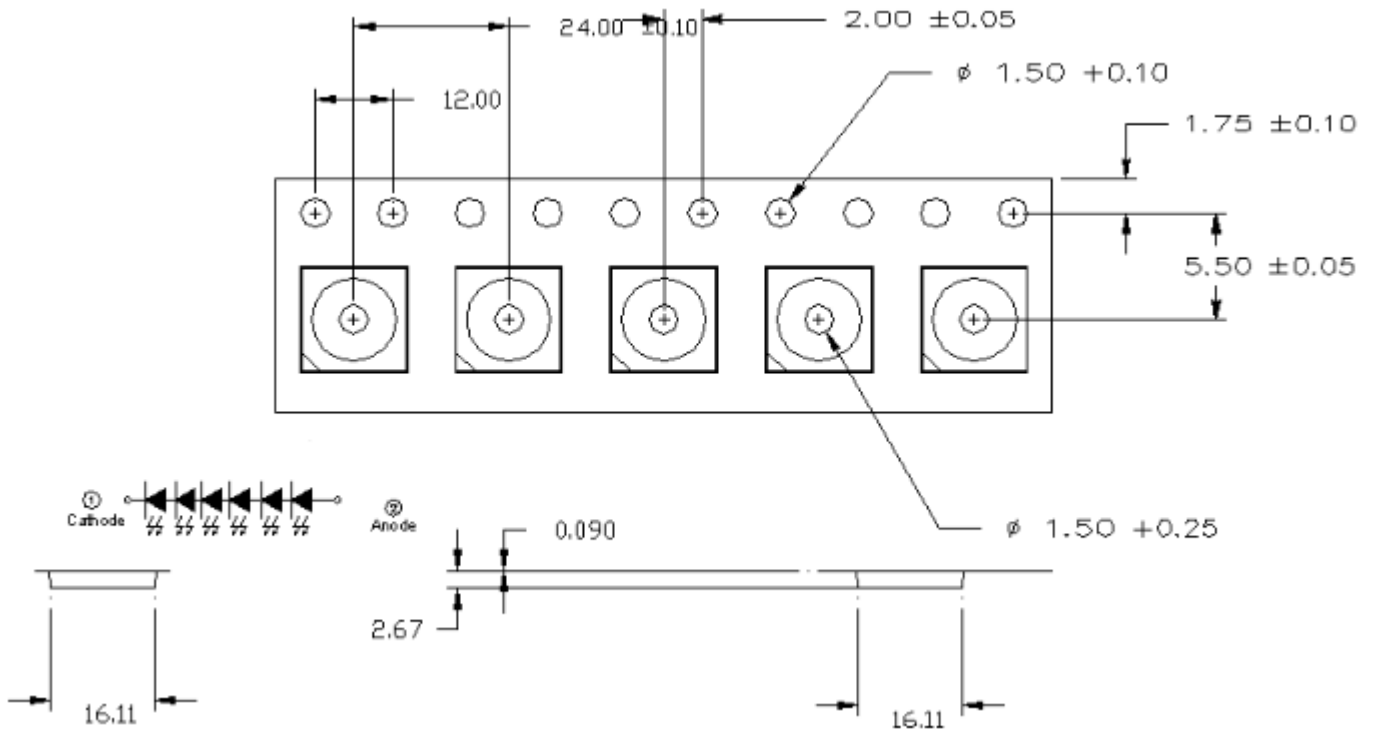

Notes:

1. Tolerance unless mentioned is $\pm 0.1\text{mm}$; Unit = mm
2. Minimum packing amount is 250/500/1000/1500 pcs per reel

Moisture Resistant Packaging

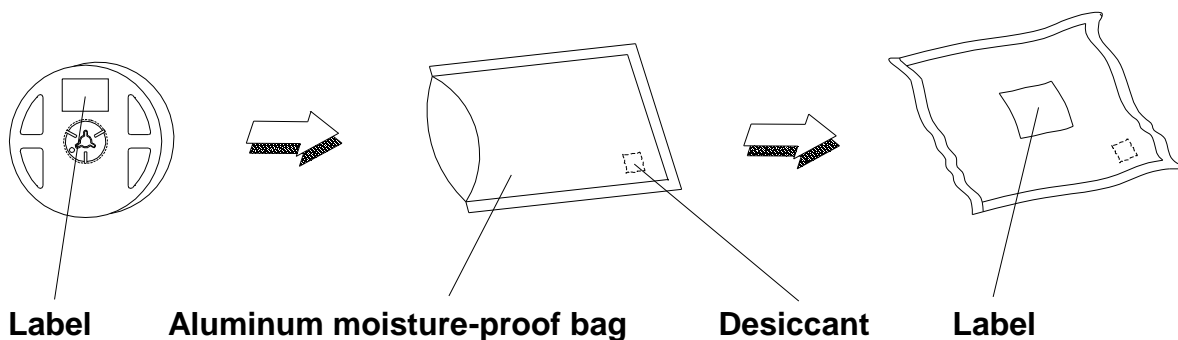

Emitter Reel Packaging

Reel Dimensions

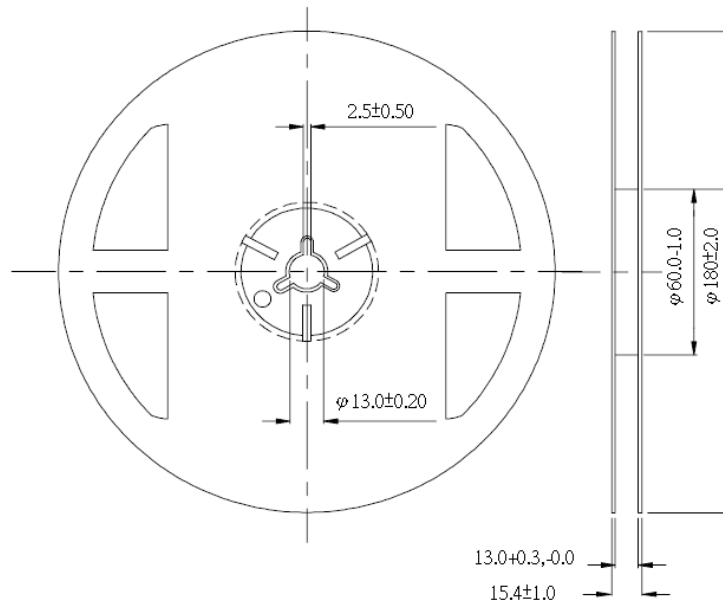

Notes:

1. Dimensions are in millimeters.
2. Tolerances unless mentioned are ± 0.1 mm.

Product Labeling

Label Explanation

CPN: Customer Specification (when required)

P/N : Everlight Production Number

QTY: Packing Quantity

CAT: Luminous Flux (Brightness) Bin

HUE: Color Bin

REF: Forward Voltage Bin

LOT No: Lot Number

MADE IN TAIWAN: Production Place



Reliability Data

Stress Test	Stress Condition	Stress Duration
Reflow	Tsol=260 , 10sec	3 times
Thermal Shock	H : + 100 20min. 10sec. L : - 10 20min.	500,1000 Cycles
Power Temperature Cycle	H : + 85 15min. 5min. L : - 40 15min. IF=200mA	500,1000 Cycles
High Temperature/Humidity Operation	Ta=85 , RH=85%, IF=160mA	1000hours
Room Temperature Operation Life	Ta=25 , IF=200mA	1000hours
High Temperature Operation Life #1	Ta=55 , IF=200mA	1000hours
High Temperature Operation Life #2	Ta=85 , IF=160mA	1000hours
Low Temperature Operation Life	Ta=-40 , IF=200mA	1000hours
Pulse	30ms ON/2500ms OFF / 30000 Cycles IF=260mA	30ms ON/2500ms OFF / 30000 Cycles

Failure Criteria:

1. LEDs are open or shorted
2. Im: luminous flux attenuate difference(1000hrs)>50%
3. VF: forward voltage difference(1000hrs)>20%

Storage Conditions

- Before the package is opened: The LEDs should be stored at 30°C or less and 90%RH or less after being shipped from Everlight. The storage life is 18 months. If the LEDs are to be stored for more than 6 months, they should be stored in a sealed container with a nitrogen atmosphere and moisture absorbent material.
- After opening the package: The LED's should be stored under 30°C or less and 60%RH or less. The LED should be used within 168hrs (7days) after opening the package. If unused LEDs remain, they should be stored in moisture proof packages.
- Before using LEDs: The LEDs should be baked under the following conditions: pre-curing at 60±5°C for 24 hours.
- Do not stack assemblies containing Everlight XI5050 LEDs to prevent damage to the optical surface of LEDs. Forces applied to the optical surface may result in the surface being damaged.

EVERLIGHT

Revision History

Current version: 02.06.2015
Issue No: DHE-0002692
Version: 1
Created by: Betty Hong

Page	Subjects (major change in previous version)	Date of change

EVERLIGHT