

Features

- Wide 4.5V to 40V Input Voltage Range
- Output Adjustable from 1.23V to 37V
- Maximum Duty Cycle 98%
- Minimum Drop Out 1.5V
- Fixed 52KHz Switching Frequency
- 2A Constant Output Current Capability
- Internal Optimize Power Transistor
- High efficiency
- Excellent line and load regulation
- TTL shutdown capability
- ON/OFF pin with hysteresis function
- Built in thermal shutdown function
- Built in current limit function
- SOP8-EP (Exposed PAD) package

Applications

- Car Charger
- LCD Monitor and LCD TV
- Digital Photo Frame
- Set-up Box
- ADSL Modem
- Telecom / Networking Equipment

General Description

The XL2576P is a 52 KHz fixed frequency PWM buck (step-down) DC/DC converter, capable of driving a 2A load with high efficiency, low ripple and excellent line and load regulation. Requiring a minimum number of external components, the regulator is simple to use and include internal frequency compensation and a fixed-frequency oscillator.

The PWM control circuit is able to adjust the duty ratio linearly from 0 to 98%. An enable function, an over current protection function is built inside. An internal compensation block is built in to minimize external component count.

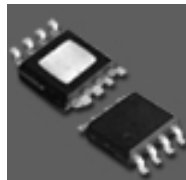

Figure1. Package Type of XL2576P

2A 52KHz 40V Buck DC to DC Converter	XL2576P
--------------------------------------	---------

Pin Configurations

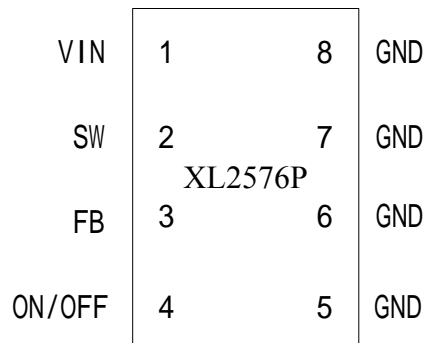

Figure2. Pin Configuration of XL2576P (Top View)

Table 1 Pin Description

Pin Number	Pin Name	Description
1	VIN	Supply Voltage Input Pin. XL2576P operates from a 4.5V to 40V DC voltage. Bypass Vin to GND with a suitably large capacitor to eliminate noise on the input.
2	OUTPUT	Power Switch Output Pin (SW). Output is the switch node that supplies power to the output.
5,6,7,8	GND	Ground Pin. The exposed PAD is ground.
3	FEEDBACK	Feedback Pin (FB). Through an external resistor divider network, Feedback senses the output voltage and regulates it. The feedback threshold voltage is 1.23V.
4	ON/OFF	Enable Pin. Drive ON/OFF pin low to turn on the device, drive it high to turn it off. Floating is default low.

2A 52KHz 40V Buck DC to DC Converter	XL2576P
--------------------------------------	---------

Function Block

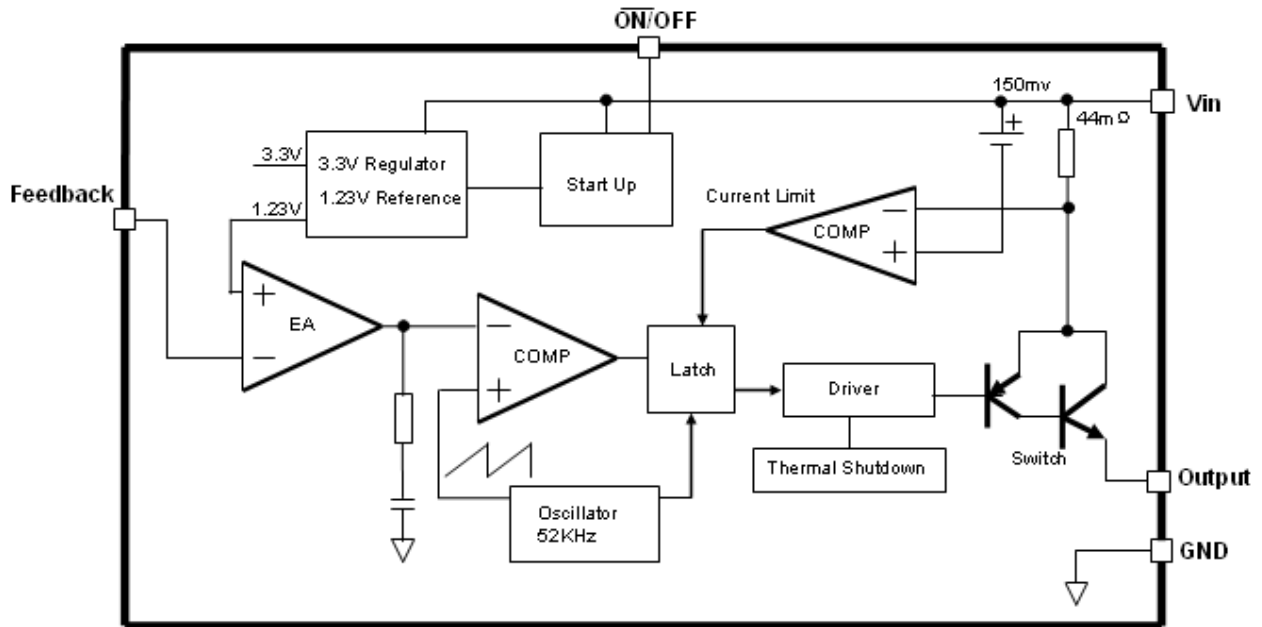

Figure3. Function Block Diagram of XL2576P

Typical Application Circuit

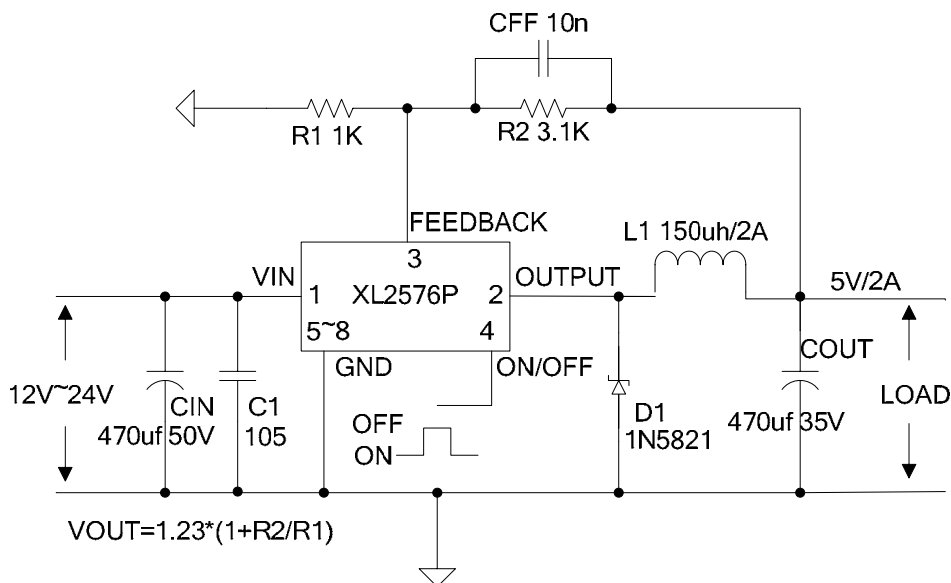

Figure4. XL2576P Typical Application Circuit

2A 52KHz 40V Buck DC to DC Converter

XL2576P

Ordering Information

Package	Temperature Range	Part Number	Marking ID	Packing Type
		Lead Free	Lead Free	
		XL2576P	XL2576P	

Absolute Maximum Ratings (Note1)

Parameter	Symbol	Value	Unit
Input Voltage	V _{in}	-0.3 to 45	V
Feedback Pin Voltage	V _{FB}	-0.3 to V _{in}	V
ON/OFF Pin Voltage	V _{ON/OFF}	-0.3 to V _{in}	V
Output Switch Pin Voltage	V _{Output}	-0.3 to V _{in}	V
Power Dissipation	P _D	Internally limited	mW
Thermal Resistance (SOP8-EP) (Junction to Ambient, No Heatsink, Free Air)	R _{JA}	50	°C/W
Operating Junction Temperature	T _J	-40 to 125	°C
Storage Temperature	T _{STG}	-65 to 150	°C
Lead Temperature (Soldering, 10 sec)	T _{LEAD}	260	°C
ESD (HBM)		2000	V

Note1: Stresses greater than those listed under Maximum Ratings may cause permanent damage to the device. This is a stress rating only and functional operation of the device at these or any other conditions above those indicated in the operation is not implied. Exposure to absolute maximum rating conditions for extended periods may affect reliability.

2A 52KHz 40V Buck DC to DC Converter

XL2576P

XL2576P Electrical Characteristics

T_a = 25 °C ; unless otherwise specified.

Symbol	Parameter	Test Condition	Min.	Typ.	Max.	Unit
<i>System parameters test circuit figure5</i>						
VFB	Feedback Voltage	V _{in} = 12, I _{out} =0.5A, V _{out} =5V	1.206	1.23	1.254	V
VFB	Feedback Voltage	V _{in} = 8V to 40V, V _{out} =5V, I _{load} =0.5A to 2A	1.193	1.23	1.267	V
Efficiency	η	V _{in} =12V , V _{out} =5V I _{out} =2A	-	80	-	%

Electrical Characteristics (DC Parameters)

V_{in} = 12V , GND=0V, V_{in} & GND parallel connect a 220uf/50V capacitor; I_{out}=500mA, T_a = 25 °C ; the others floating unless otherwise specified.

Parameters	Symbol	Test Condition	Min.	Typ.	Max.	Unit
Input operation voltage	V _{in}		4.5		40	V
Shutdown Supply Current	I _{STBY}	V _{ON/OFF} =5V		80	200	uA
Quiescent Supply Current	I _q	V _{ON/OFF} =0V, V _{FB} =V _{in}		2	10	mA
Oscillator Frequency	F _{osc}		44	52	60	Khz
Switch Current Limit	I _L	V _{FB} =0		3.5		A
ON/OFF Pin Threshold	V _{ON/OFF}	High (Regulator OFF) Low (Regulator ON)		1.4 0.8		V
ON/OFF Pin Input Leakage Current	I _H	V _{ON/OFF} =2.5V (OFF)		5	15	uA
	I _L	V _{ON/OFF} =0.5V (ON)		0.2	5	uA
Output Saturation Voltage	V _{CE}	V _{FB} =0V I _{out} =2A		1.2	1.5	V
Max. Duty Cycle	D _{MAX}	V _{FB} =0V		98		%

XL2576P Output Capacitor Design Procedure

Output Voltage (V)	Through Hole Output Electrolytic			Surface Mount Output Capacitor		
	Panasonic HFQ Series (uf/V)	Nichicon PL Series (uf/V)	Feedforward Capacitor	AVX TPS Series (uf/V)	Sprague 595D Series (uf/V)	Feedforward Capacitor
2	820/35	820/35	33nf	330/6.3	470/4	33nf
4	560/35	470/35	10nf	330/6.3	390/6.3	10nf
6	470/25	470/35	3.3nf	220/10	330/10	3.3nf
9	330/25	330/25	1.5nf	100/16	180/16	1.5nf
12	330/25	330/25	1nf	100/16	180/16	1nf
15	220/25	220/35	680pf	68/20	120/20	680pf
24	220/35	150/35	560pf	33/25	33/25	220pf
28	100/50	100/50	390pf	10/35	15/50	220pf

Schottky Diode Selection Table

Current	Surface Mount	Through Hole	VR (The same as system maximum input voltage)				
			20V	30V	40V	50V	60V
1A			1N5817	1N5818	1N5819		
3A			1N5820	1N5821	1N5822		
			MBR320	MBR330	MBR340	MBR350	MBR360
			SK32	SK33	SK34	SK35	SK36
				30WQ03	30WQ04	30WQ05	
				31DQ03	31DQ04	31DQ05	
			SR302	SR303	SR304	SR305	SR306

Typical System Application

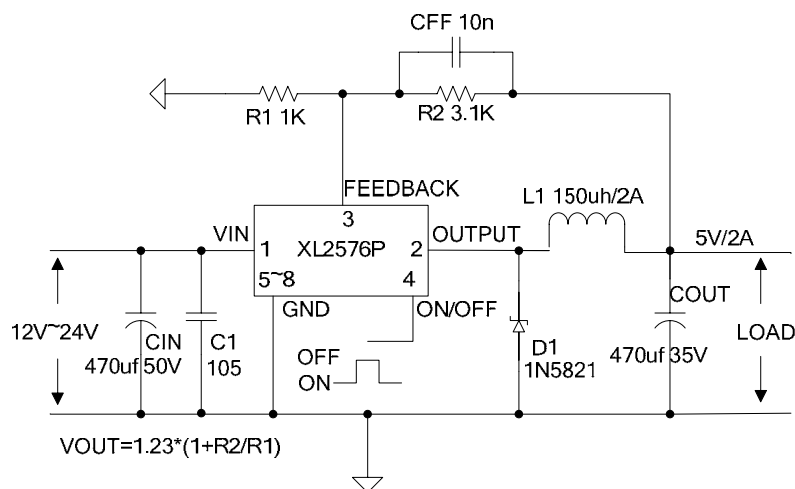
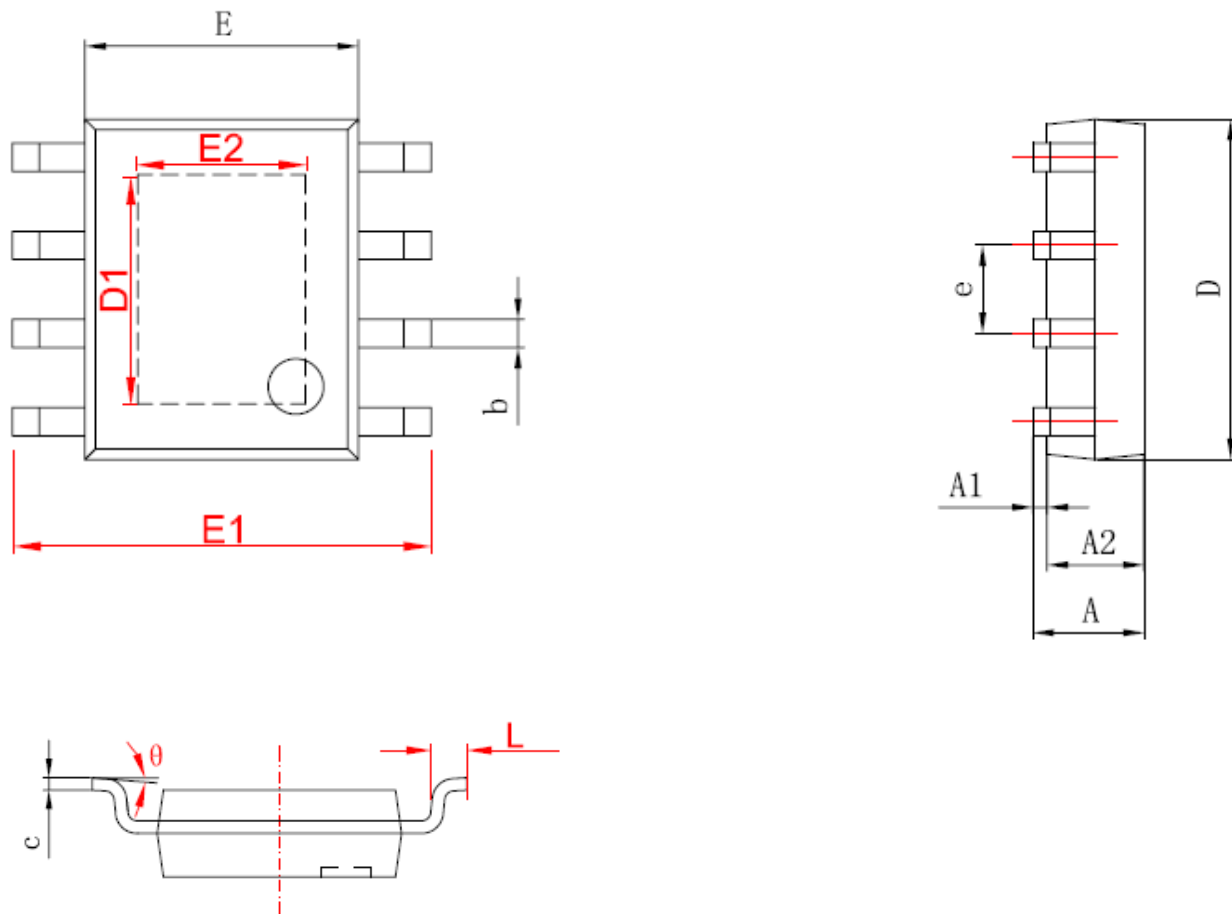

Figure5. XL2576P System Parameters Test Circuit

Package Information (SOP8-EP)



字符	Dimensions In Millimeters		Dimensions In Inches	
	Min	Max	Min	Max
A	1.350	1.750	0.053	0.069
A1	0.050	0.150	0.004	0.010
A2	1.350	1.550	0.053	0.061
b	0.330	0.510	0.013	0.020
c	0.170	0.250	0.006	0.010
D	4.700	5.100	0.185	0.200
D1	3.202	3.402	0.126	0.134
E	3.800	4.000	0.150	0.157
E1	5.800	6.200	0.228	0.244
E2	2.313	2.513	0.091	0.099
e	1.270 (BSC)		0.050 (BSC)	
L	0.400	1.270	0.016	0.050
θ	0°	8°	0°	8°