

150KHz 60V 2A Buck DC to DC Converter

XL2596HVP

Features

- Operating Voltage: 4.5V~50V
- Adjustable, 3.3V, 5.0V and 12V Versions
- Output Adjustable from 1.23V to 48V
- Maximum Duty Cycle 100%
- Feedback Voltage Accuracy $\pm 1.5\%$
- Minimum Drop Out 1.5V
- Fixed 150KHz Switching Frequency
- 2A Constant Output Current Capability
- Internal Optimize HV Power Transistor
- High efficiency up to 90%
- Excellent line and load regulation
- TTL shutdown capability
- Built in thermal shutdown function
- Built in current limit protection function
- Built in output short protection function
- Temperature Grade 1: -40°C to 125°C
Ambient Operating Temperature Range
- Device HBM ESD Classification Level Class3B
- Available in SOP8-EP package

General Description

The XL2596HVP is a 150 KHz fixed frequency buck DC/DC converter, capable of driving a 2A load with high voltage, high efficiency. The XL2596HVP supports wide input operating voltage range of 4.5V ~ 50V and a maximum duty cycle of 100% output. A built-in loop compensation module reduces components in the system, lowering power system cost and reducing printed circuit board space. The XL2596HVP is available in adjustable, fixed 3.3V, 5.0V and 12V versions. The XL2596HVP has built-in thermal shutdown, current limit protection and output short protection function and so on. When the output short protection function happens, the operation frequency will be reduced about from 150KHz to 30KHz.

Applications

- Automotive Electronics
- Industrial Control
- Networking Equipment
- Internet of Things

Typical application schematic

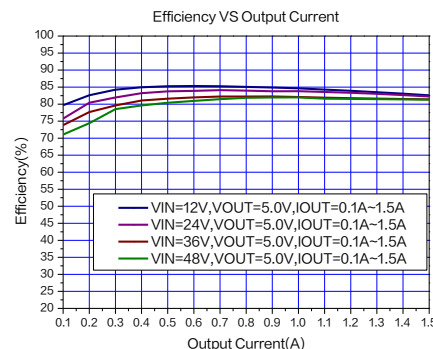
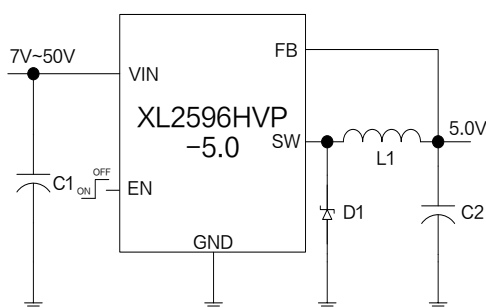

Figure1.XL2596HVP-5.0 Typical application schematic and efficiency curve

Pin Configurations

VIN	1	8	GND
SW	2	7	GND
FB	3	6	GND
EN	4	5	GND

The Exposed PAD is GND

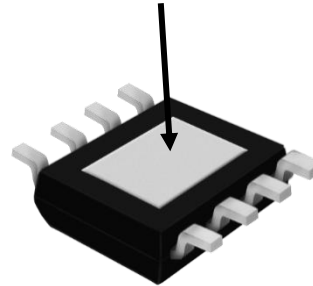

Figure2. Pin Configuration of XL2596HVP

Table 1. Pin Description

Pin Number	Pin Name	Description
1	VIN	Supply Voltage Input Pin. XL2596HVP DC operating voltage range from a 4.5V to 50V . Bypass VIN to GND with a suitably large capacitor to eliminate noise on the input.
2	SW	Power Switch Output Pin (SW). Output is the switch node that supplies power to the output.
3	FB	Feedback Pin (FB). Through an external resistor divider network, detects the output voltage for adjustment, with an adjustable version reference voltage of 1.23V.
4	EN	Enable Pin. Drive EN pin low to turn on the device, drive it high to turn it off. Floating is default low.
5~8	GND	Ground Pin.

Ordering Information

Order Information	Marking ID	Package Type	Eco Plan	Packing Type Supplied As
XL2596HVP-ADJE1	XL2596HVP-ADJE1	SOP8-EP	RoHS & HF	4000 Units on Reel
XL2596HVP-3.3E1	XL2596HVP-3.3E1	SOP8-EP	RoHS & HF	4000 Units on Reel
XL2596HVP-5.0E1	XL2596HVP-5.0E1	SOP8-EP	RoHS & HF	4000 Units on Reel
XL2596HVP-12E1	XL2596HVP-12E1	SOP8-EP	RoHS & HF	4000 Units on Reel

Function Block

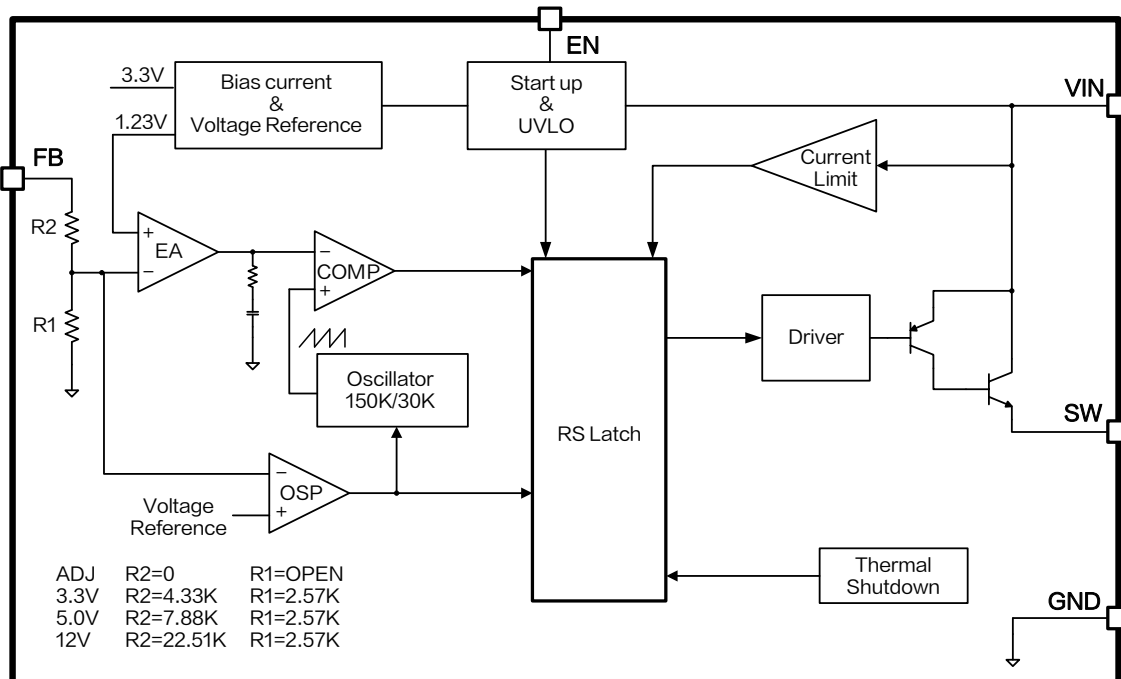

Figure3. Function Block Diagram of XL2596HVP

Absolute Maximum Ratings (Note1)

Parameter	Symbol	Value	Unit
Input Voltage	V_{IN}	-0.3~60	V
Feedback Pin Voltage	V_{FB}	-0.3~20	V
EN Pin Voltage	V_{EN}	-0.3~7	V
Output Switch Pin Voltage	V_{SW}	-0.3~ V_{IN}	V
Power Dissipation	P_D	Internally limited	mW
Thermal Resistance (SOP8-EP) (Junction to Ambient, No Heatsink, Free Air)	R_{JA}	60	°C/W
Operating Junction Temperature	T_J	-40~150	°C
Storage Temperature	T_{STG}	-65~150	°C
Lead Temperature (Soldering, 10 sec)	T_{LEAD}	260	°C
ESD (HBM)		> 8000	V

Note1: Stresses greater than those listed under Maximum Ratings may cause permanent damage to the device. This is a stress rating only and functional operation of the device at these or any other conditions above those indicated in the operation is not implied. Exposure to absolute maximum rating conditions for extended periods may affect reliability.

150KHz 60V 2A Buck DC to DC Converter

XL2596HVP

XL2596HVP –ADJ Electrical Characteristics

T_A = 25°C; System parameters test circuit figure4 and figure6, unless otherwise specified.

Symbol	Parameter	Test Condition	Min.	Typ.	Max.	Unit
V _{FB}	Feedback Voltage	V _{IN} = 12V, V _{OUT} = 5.0V I _{OUT} = 0.5A	1.212	1.23	1.248	V
η	Efficiency	V _{IN} = 12V, V _{OUT} = 5.0V I _{OUT} = 1.5A	–	82.6	–	%
η	Efficiency	V _{IN} = 24V, V _{OUT} = 15V I _{OUT} = 0.7A	–	92.2	–	%

XL2596HVP–3.3 Electrical Characteristics

T_A = 25°C; System parameters test circuit figure8, unless otherwise specified.

Symbol	Parameter	Test Condition	Min.	Typ.	Max.	Unit
V _{OUT}	Output Voltage	V _{IN} = 12V I _{OUT} = 0.5A	3.250	3.3	3.350	V
η	Efficiency	V _{IN} = 12V, V _{OUT} = 3.3V I _{OUT} = 1.5A	–	77.3	–	%

XL2596HVP –5.0 Electrical Characteristics

T_A = 25°C; System parameters test circuit figure10, unless otherwise specified.

Symbol	Parameter	Test Condition	Min.	Typ.	Max.	Unit
V _{OUT}	Output Voltage	V _{IN} = 12V I _{OUT} = 0.5A	4.925	5.0	5.075	V
η	Efficiency	V _{IN} = 12V, V _{OUT} = 5.0V I _{OUT} = 1.5A	–	82.6	–	%

XL2596HVP –12 Electrical Characteristics

T_A = 25°C; System parameters test circuit figure12, unless otherwise specified.

Symbol	Parameter	Test Condition	Min.	Typ.	Max.	Unit
V _{OUT}	Output Voltage	V _{IN} = 24V I _{OUT} = 0.25A	11.82	12	12.18	V
η	Efficiency	V _{IN} = 24V, V _{OUT} = 12V I _{OUT} = 0.7A	–	91.0	–	%

150KHz 60V 2A Buck DC to DC Converter

XL2596HVP

Electrical Characteristics (DC Parameters)

$T_A = 25^\circ\text{C}$, $V_{IN}=12\text{V}$, $V_{EN}=0\text{V}$, System parameters test circuit figure4, unless otherwise specified.

Parameters	Symbol	Test Condition	Min.	Typ.	Max.	Unit
Operating Voltage	V_{IN}		4.5		50	V
Shutdown Current	I_S	$V_{EN}=2\text{V}$		46	100	μA
Quiescent Current	I_Q	Note2		1.3	2.0	mA
Oscillator Frequency	F_{OSC}		135	150	165	KHz
Switch Current Limit	I_L	$V_{FB}=0\text{V}$		3.0		A
EN Pin Threshold Voltage	V_{EN_H}	High (Regulator OFF)	1.4			V
	V_{EN_L}	Low (Regulator ON)			0.8	V
EN Pin Current	I_{EN}	$V_{EN}=2.0\text{V}$		5		μA
Output Saturation Voltage	V_{CE}	$V_{FB}=0\text{V}$ $I_{OUT}=2\text{A}$		1.1	1.3	V
Max. Duty Cycle	D_{MAX}	$V_{FB}=0\text{V}$		100		%
Thermal Shutdown Temperature	T_{SD}			180		$^\circ\text{C}$
Thermal Shutdown Hysteresis	T_D			50		$^\circ\text{C}$

Note 2: In the adjustable, fixed 3.3V and 5.0V versions, $V_{FB}=10\text{V}$; In the fixed 12V version, $V_{FB}=15\text{V}$.

150KHz 60V 2A Buck DC to DC Converter **XL2596HVP**

Typical System Application Schematic for ADJ Version

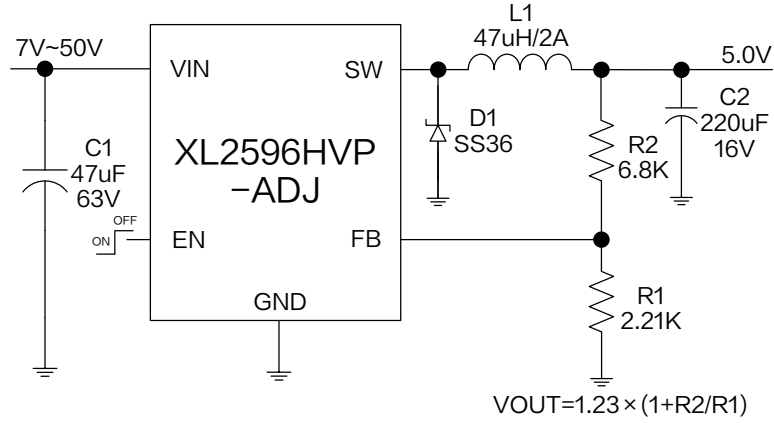

Figure4. XL2596HVP-ADJ System Parameters Test Circuit($V_{OUT}=5.0V$)

Typical System Application Transfer Efficiency

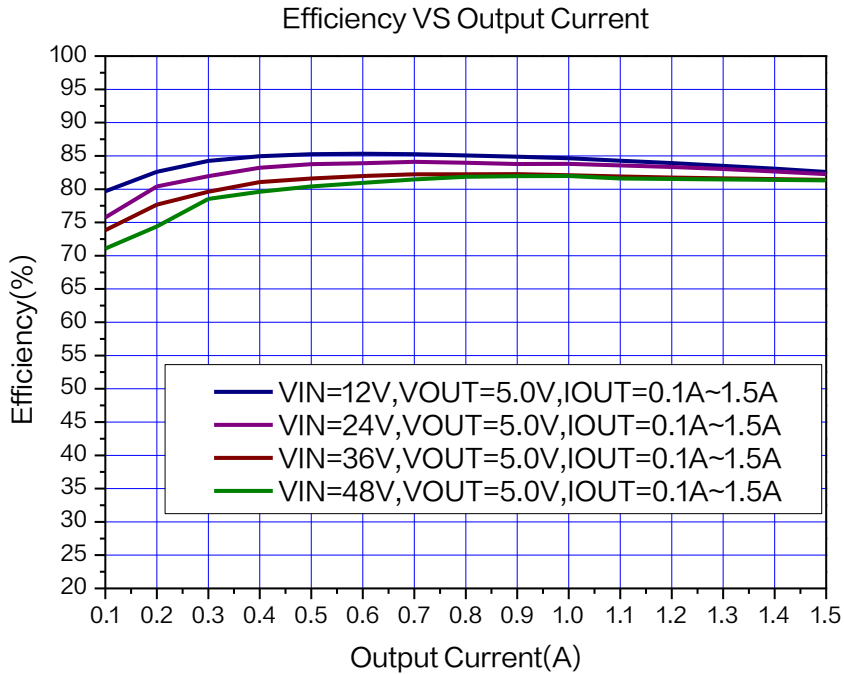

Figure5. XL2596HVP-ADJ System Efficiency Curve

150KHz 60V 2A Buck DC to DC Converter **XL2596HVP**

Typical System Application Schematic for ADJ Version

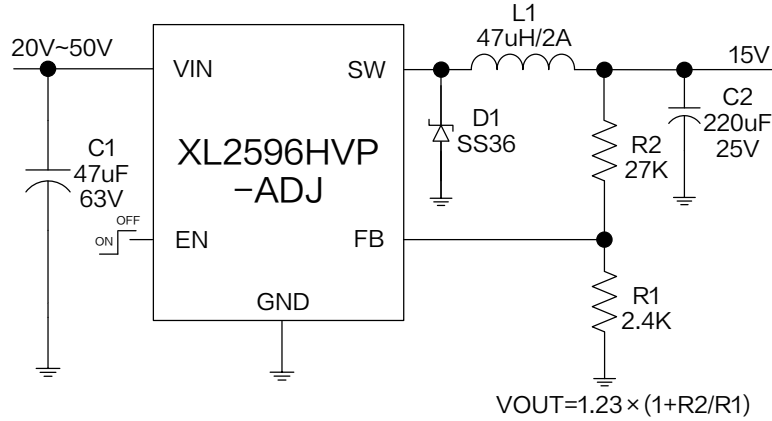

Figure6. XL2596HVP-ADJ System Parameters Test Circuit($V_{OUT}=15V$)

Typical System Application Transfer Efficiency

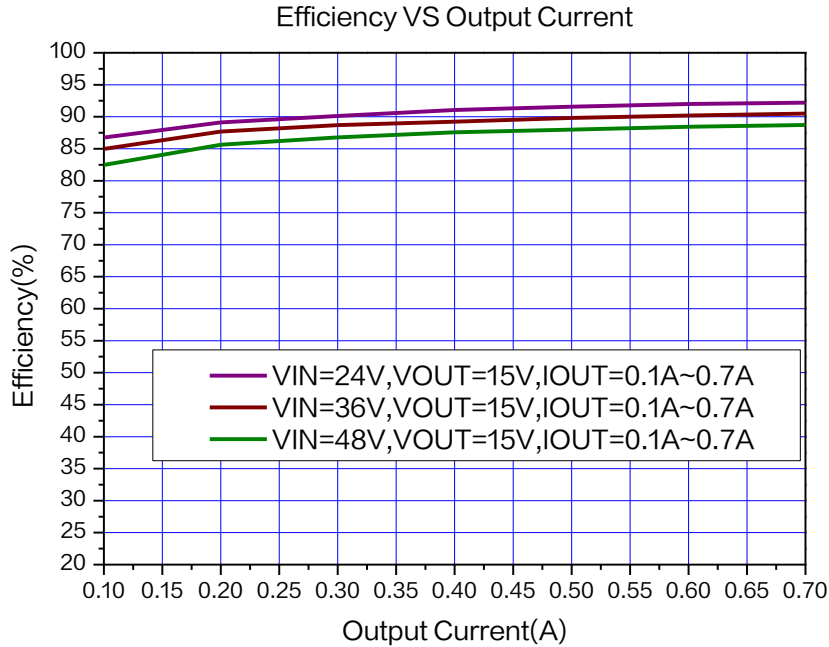

Figure7. XL2596HVP-ADJ System Efficiency Curve

150KHz 60V 2A Buck DC to DC Converter	XL2596HVP
---------------------------------------	-----------

Typical System Application Schematic for 3.3V Version

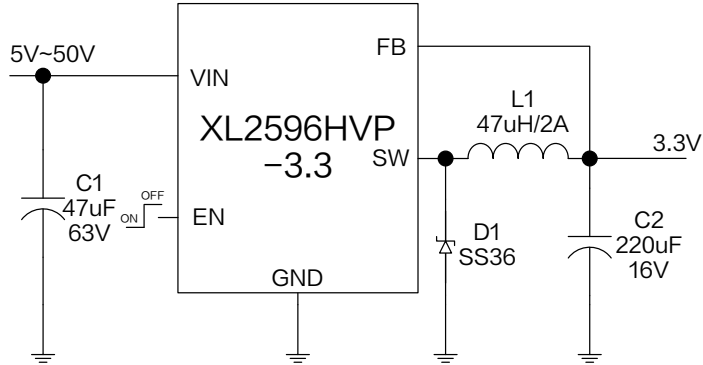

Figure8. XL2596HVP-3.3 System Parameters Test Circuit

Typical System Application Transfer Efficiency

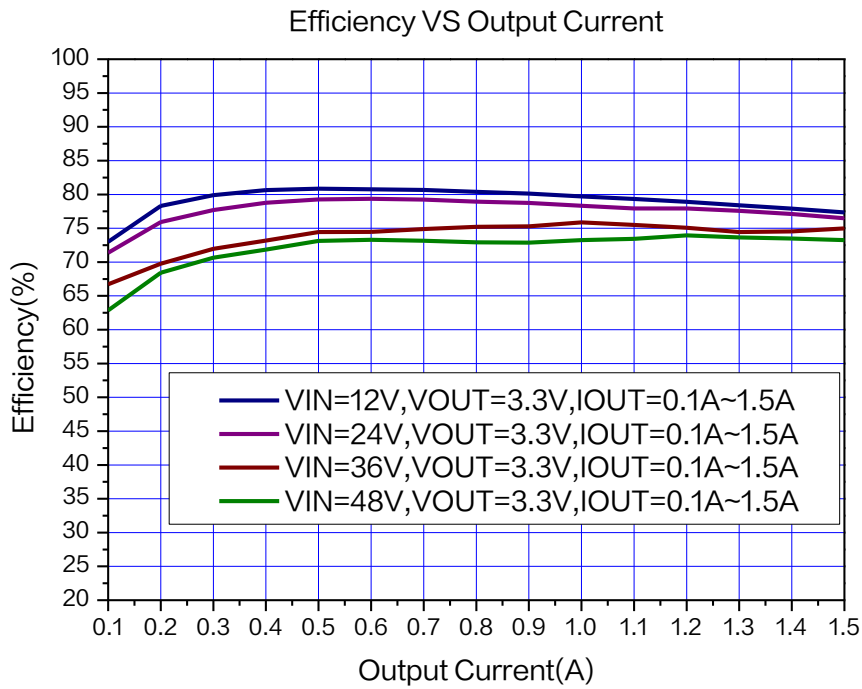

Figure9. XL2596HVP-3.3 System Efficiency Curve

Typical System Application Schematic for 5.0V Version

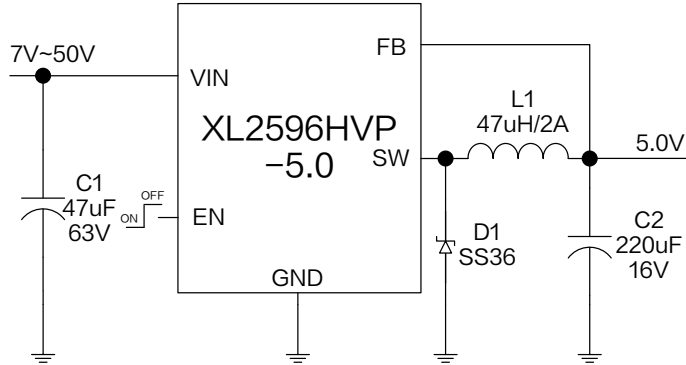

Figure10. XL2596HVP-5.0 System Parameters Test Circuit

Typical System Application Transfer Efficiency

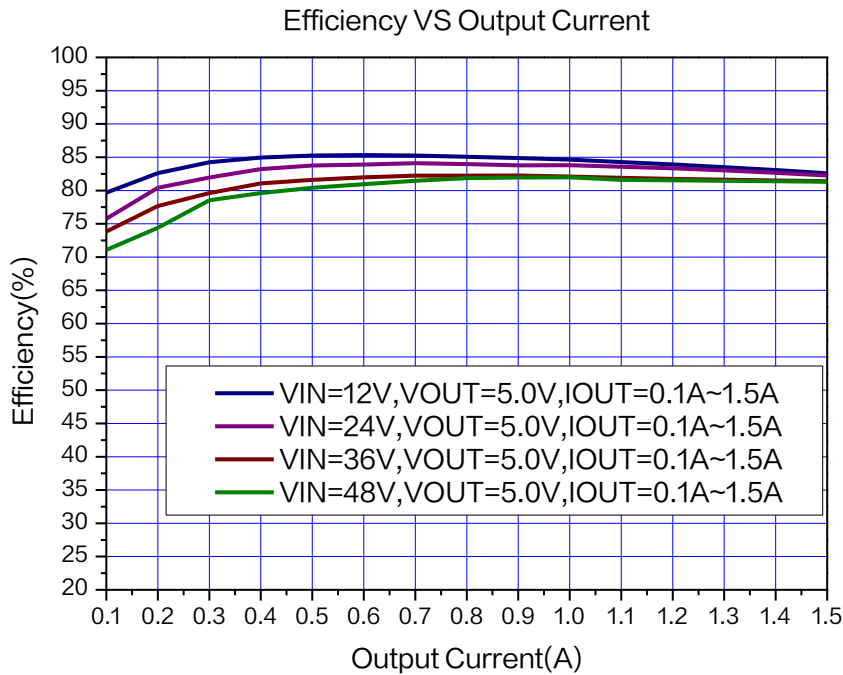

Figure11. XL2596HVP-5.0 System Efficiency Curve

150KHz 60V 2A Buck DC to DC Converter XL2596HVP

Typical System Application Schematic for 12V Version

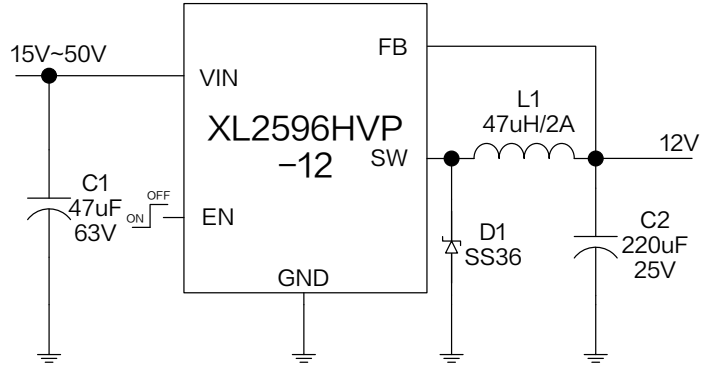

Figure12. XL2596HVP-12 System Parameters Test Circuit

Typical System Application Transfer Efficiency

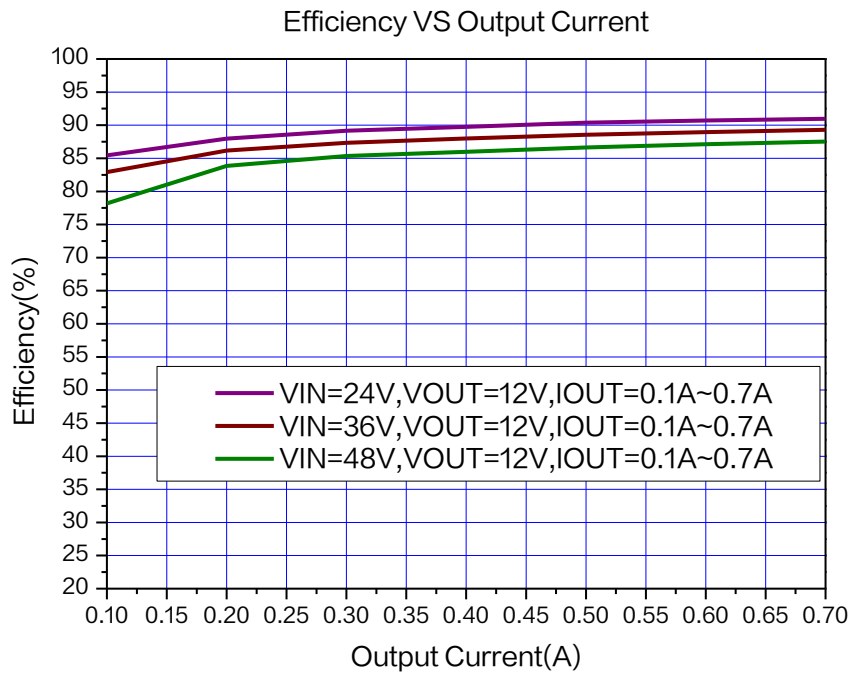
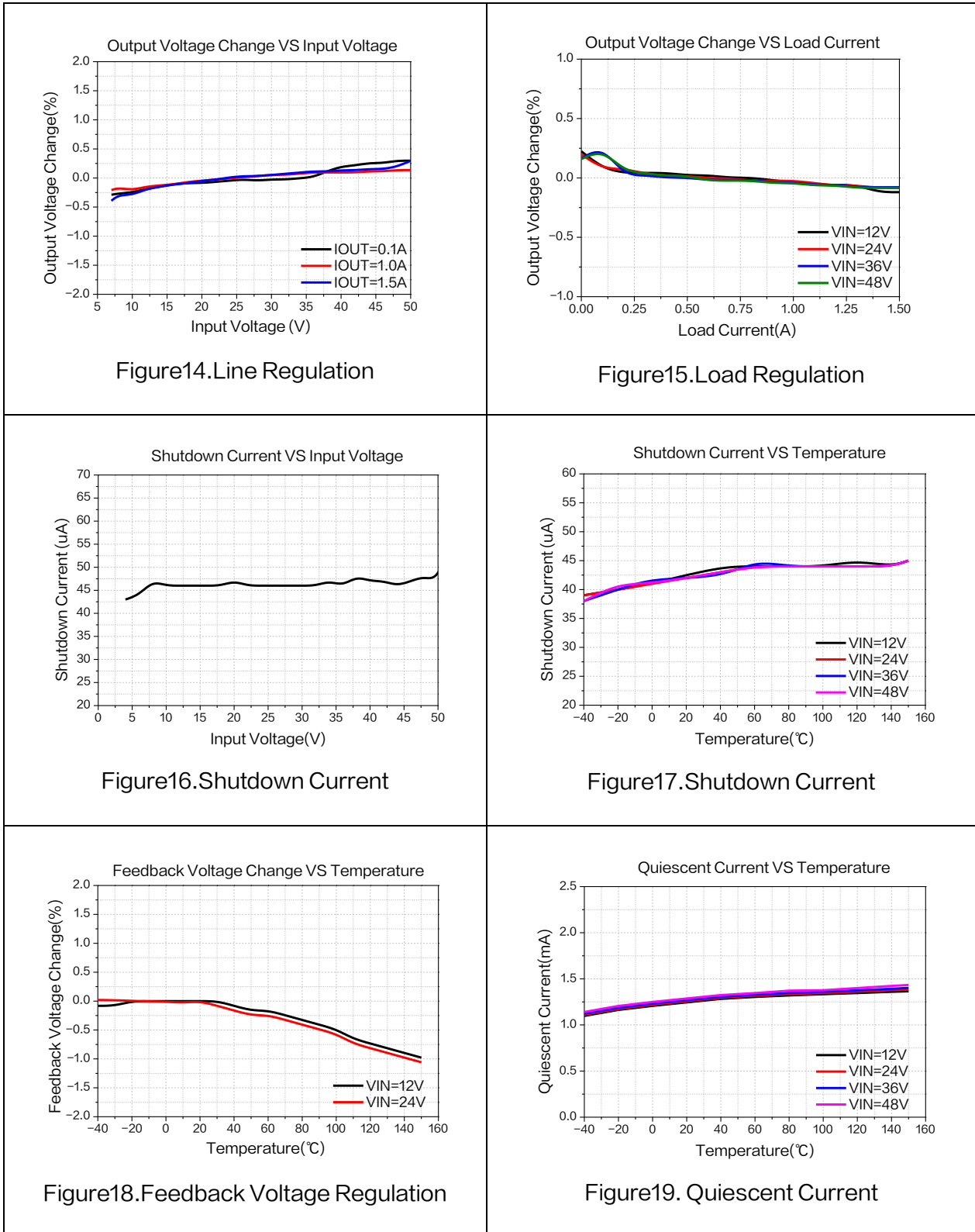

Figure13. XL2596HVP-12 System Efficiency Curve

Typical Characteristics



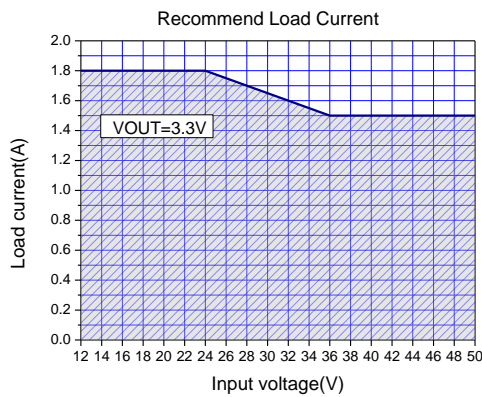

Figure 20.Max Output Current
(V_{OUT}=3.3V, T_A=25°C)

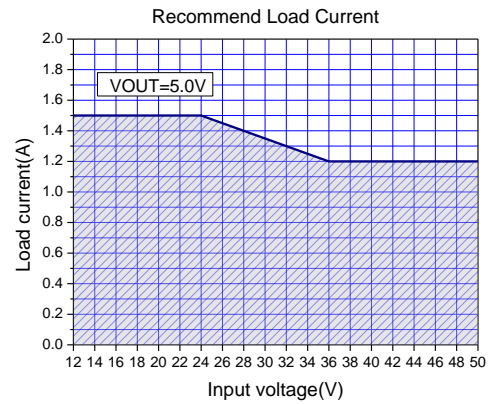

Figure 21.Max Output Current
(V_{OUT}=5.0V, T_A=25°C)

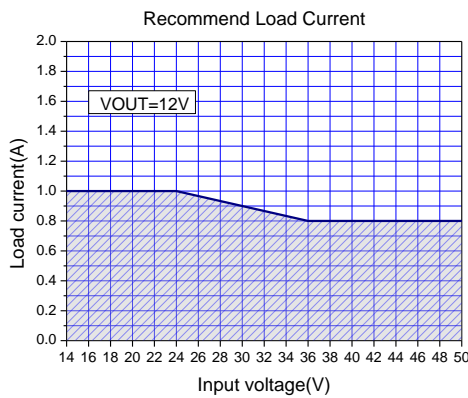

Figure 22.Max Output Current
(V_{OUT}=12V, T_A=25°C)

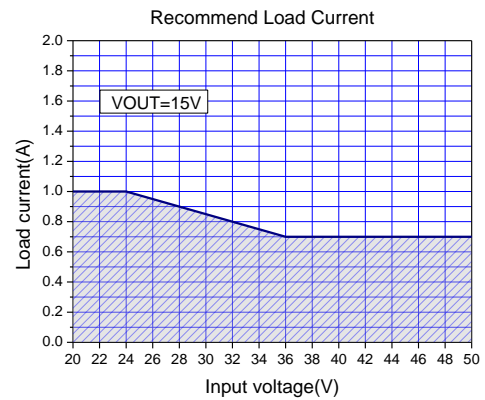

Figure 23.Max Output Current
(V_{OUT}=15V, T_A=25°C)

150KHz 60V 2A Buck DC to DC Converter

XL2596HVP

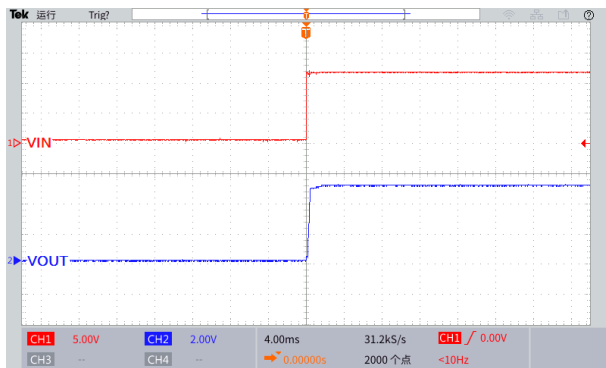

Figure 24. Start-Up Characteristic
($V_{IN}=12V$, $V_{OUT}=5.0V$, $I_{OUT}=0.1A$)

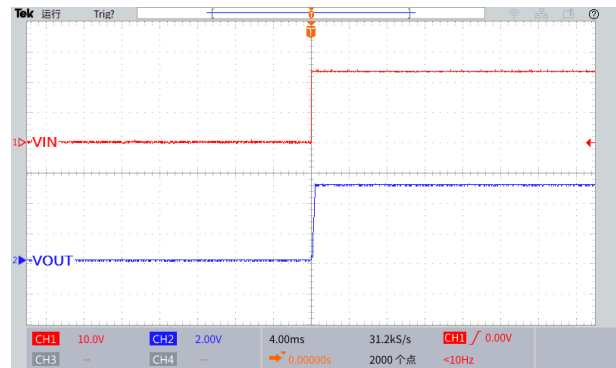

Figure 25. Start-Up Characteristic
($V_{IN}=24V$, $V_{OUT}=5.0V$, $I_{OUT}=0.1A$)

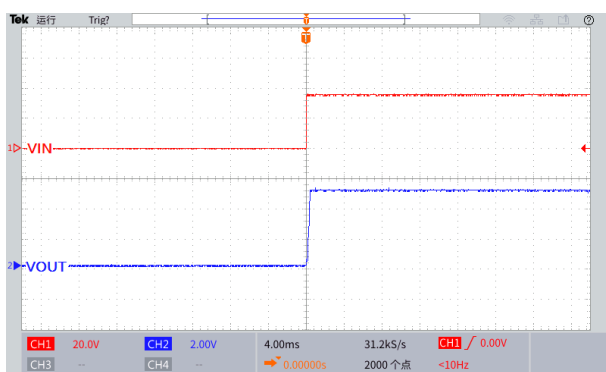

Figure 26. Start-Up Characteristic
($V_{IN}=36V$, $V_{OUT}=5.0V$, $I_{OUT}=0.1A$)

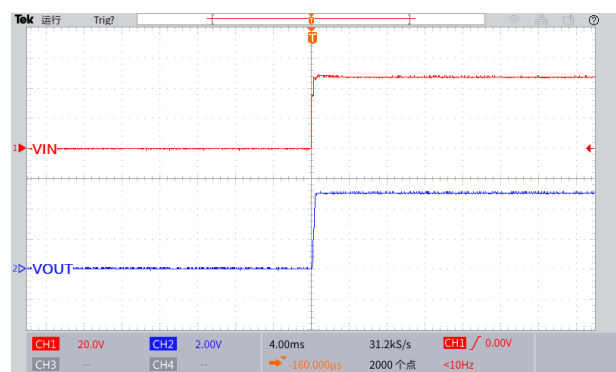

Figure 27. Start-Up Characteristic
($V_{IN}=48V$, $V_{OUT}=5.0V$, $I_{OUT}=0.1A$)

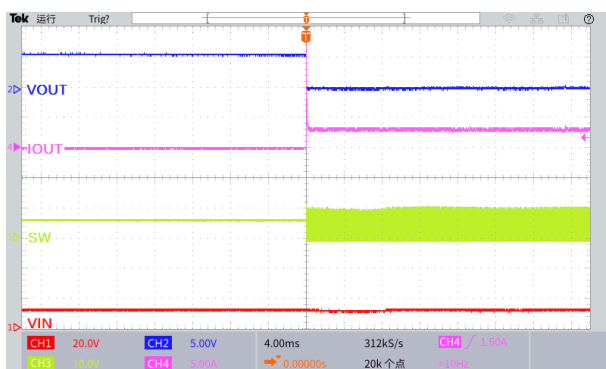

Figure 28. Output Short Circuit Waveform
($V_{IN}=12V$, $V_{OUT}=5.0V$)

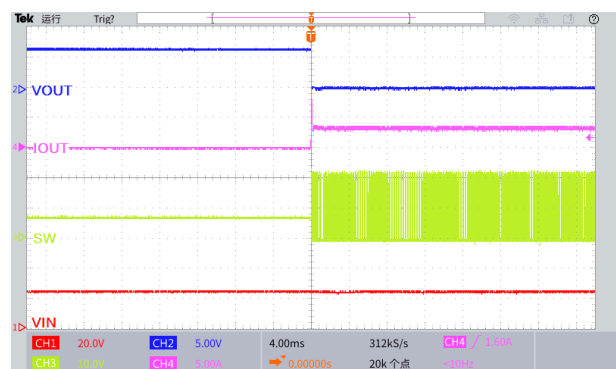

Figure 29. Output Short Circuit Waveform
($V_{IN}=24V$, $V_{OUT}=5.0V$)

150KHz 60V 2A Buck DC to DC Converter

XL2596HVP

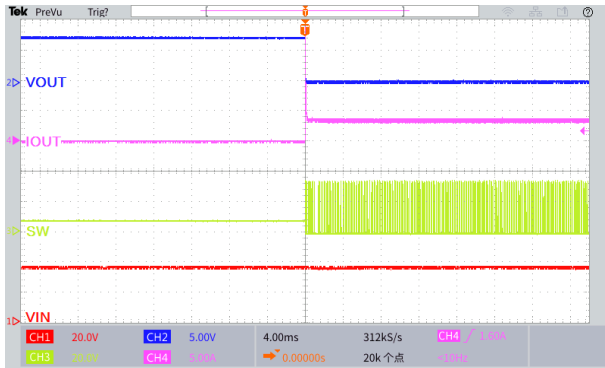

Figure 30. Output Short Circuit Waveform
($V_{IN}=36V$, $V_{OUT}=5.0V$)

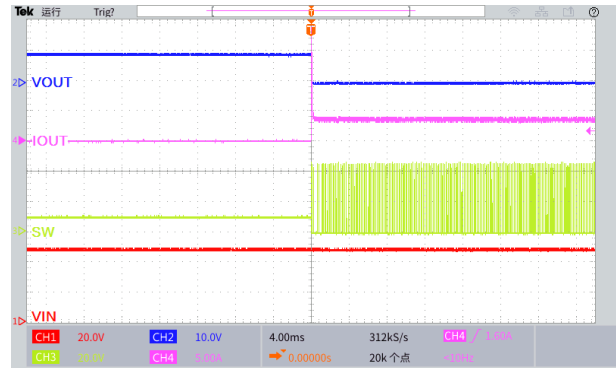

Figure 31. Output Short Circuit Waveform
($V_{IN}=48V$, $V_{OUT}=5.0V$)

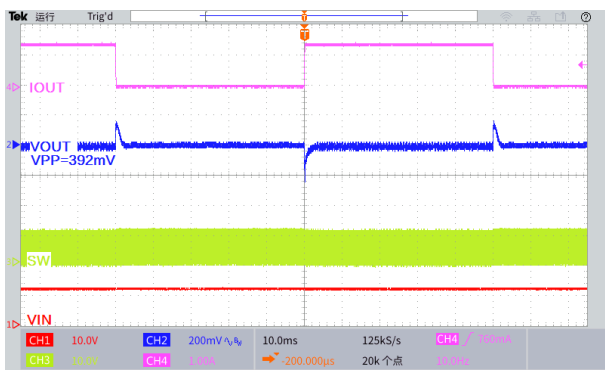

Figure 32. Load Transient Response
($V_{IN}=12V$, $V_{OUT}=5.0V$, $I_{OUT}=0.1$ to $1.5A$)

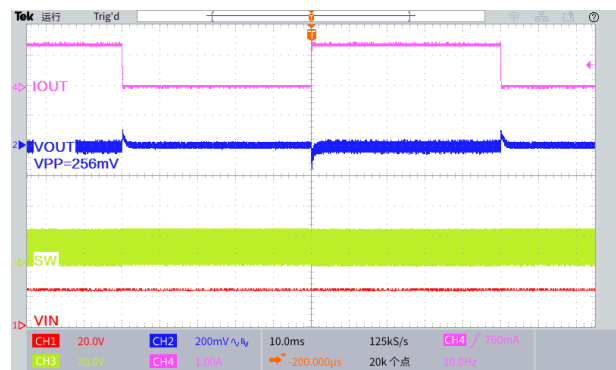

Figure 33. Load Transient Response
($V_{IN}=24V$, $V_{OUT}=5.0V$, $I_{OUT}=0.1$ to $1.5A$)

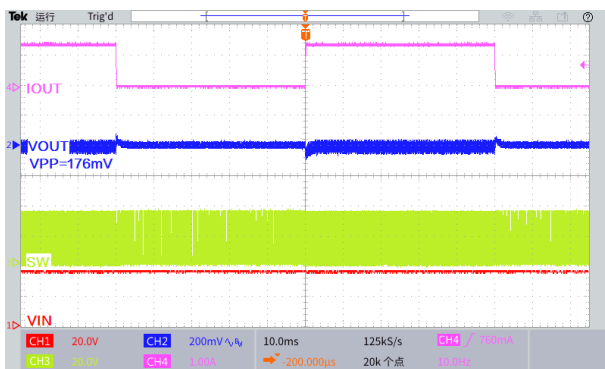

Figure 34. Load Transient Response
($V_{IN}=36V$, $V_{OUT}=5.0V$, $I_{OUT}=0.1$ to $1.5A$)

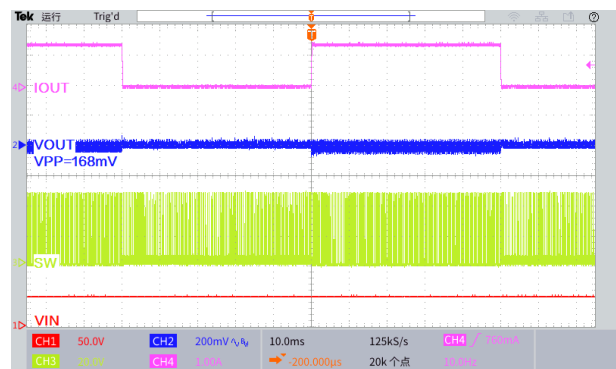

Figure 35. Load Transient Response
($V_{IN}=48V$, $V_{OUT}=5.0V$, $I_{OUT}=0.1$ to $1.5A$)

150KHz 60V 2A Buck DC to DC Converter

XL2596HVP

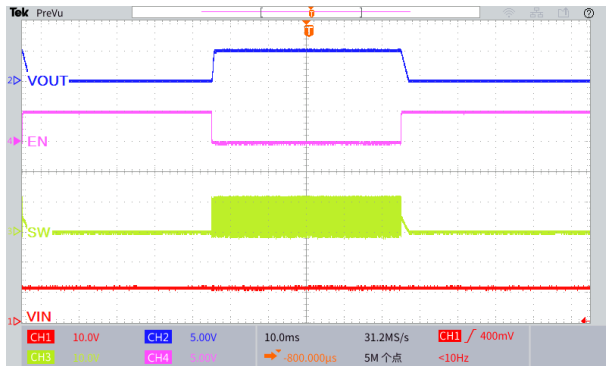

Figure36. Start or Shutdown Using EN Pin
($V_{IN}=12V$, $V_{OUT}=5.0V$, $I_{OUT}=0.5A$)

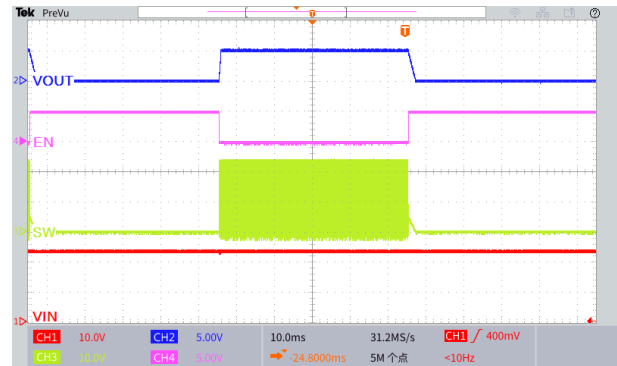

Figure37. Start or Shutdown Using EN Pin
($V_{IN}=24V$, $V_{OUT}=5.0V$, $I_{OUT}=0.5A$)

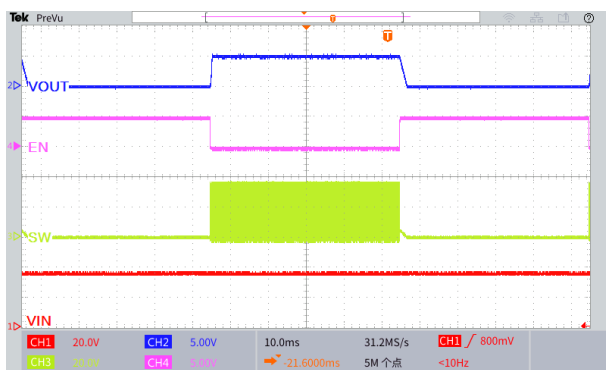

Figure38. Start or Shutdown Using EN Pin
($V_{IN}=36V$, $V_{OUT}=5.0V$, $I_{OUT}=0.5A$)



Figure39. Start or Shutdown Using EN Pin
($V_{IN}=48V$, $V_{OUT}=5.0V$, $I_{OUT}=0.5A$)

Package Information

SOP8-EP

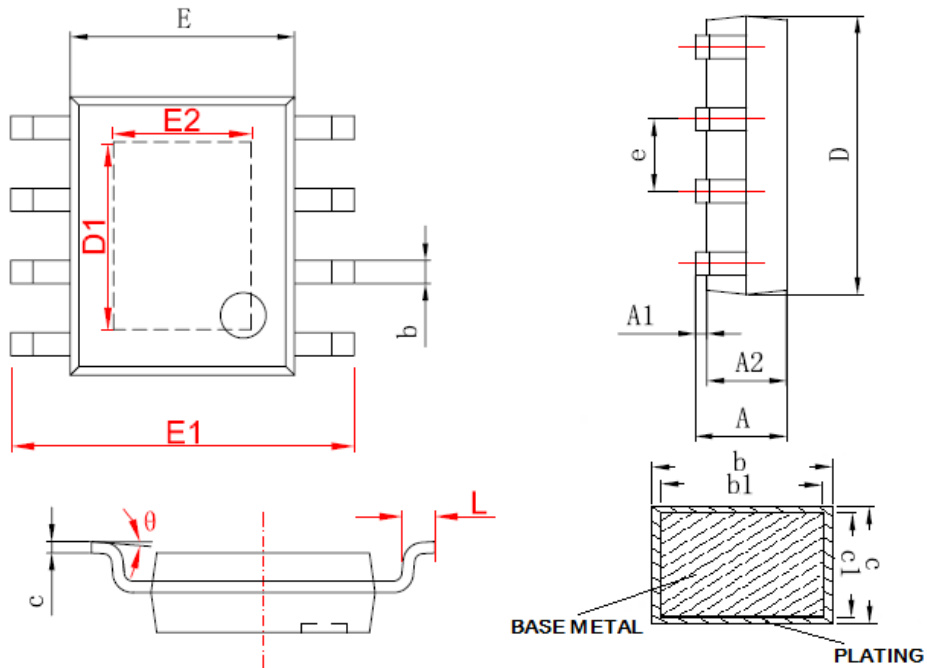

Symbol	Dimensions In Millimeters		Dimensions In Inches	
	Min.	Max.	Min.	Max.
A	1.350	1.750	0.053	0.069
A1	0.000	0.150	0.000	0.006
A2	1.250	1.650	0.049	0.065
b	0.306	0.510	0.012	0.020
b1	0.296	0.480	0.011	0.019
c	0.170	0.250	0.006	0.010
c1	0.170	0.230	0.006	0.009
D	4.700	5.100	0.185	0.200
D1	2.650	3.467	0.104	0.136
E	3.800	4.000	0.150	0.157
E1	5.800	6.200	0.228	0.244
E2	1.930	2.534	0.076	0.100
e	1.140	1.400	0.045	0.055
L	0.450	0.800	0.017	0.031
θ	0°	8°	0°	8°

150KHz 60V 2A Buck DC to DC Converter**XL2596HVP**

Important Notice

XLSEMI reserve the right to make modifications, enhancements, improvements, corrections or other changes without notice at any time. XLSEMI does not assume any liability arising out of the application or use of any product described herein; neither does it convey any license under its patent rights, nor the rights of others. XLSEMI assumes no liability for applications assistance or the design of Buyers' products. Buyers are responsible for their products and applications using XLSEMI components. To minimize the risks associated with Buyers' products and applications, Buyers should provide adequate design and operating safeguards. XLSEMI warrants performance of its products to the specifications applicable at the time of sale, in accordance with the warranty in XLSEMI's terms and conditions of sale of semiconductor products. Testing and other quality control techniques are used to the extent XLSEMI deems necessary to support this warranty. Except where mandated by applicable law, testing of all parameters of each component is not necessarily performed.

For the latest product information, go to www.xlsemi.com.