

600V 0.5A Switching Current Buck PFM LED Constant Current Driver**XL5003****Features**

- n Operate from a rectified 85V~265V AC mains supply.
- n 0.2V current sense voltage reference.
- n Directly drive 2~8 series 1W LED.
- n Excellent line and load regulation.
- n Internal optimize power HV-MOSFET.
- n Built in thermal shutdown function.
- n Built in UVLO function.
- n Built in current limiting function.
- n Built in LED open & short protection.
- n Built in soft-start circuit.
- n Support without electrolytic capacitor System solution.
- n Available in SOIC-8 package.
- n PF > 0.9 (Power Factor) with suitable External components.

General Description

The XL5003 is a monolithic high voltage switching regulator with PFM that is specifically designed to operate from a rectified 85V~265V AC mains supply.

The XL5003 is a high efficiency LED driver switching regulator. The LED string is driven at DC constant current rather than constant voltage, thus providing constant current output and enhanced reliability.

Applications

- n E27, GU10, GU5.3, B22 lamp device
- n LED daylight lamp
- n LED Lighting & LED LAMP
- n General purpose lighting



SOIC-8

Figure1. Package Type of XL5003

600V 0.5A Switching Current Buck PFM LED Constant Current Driver **XL5003**

Pin Configurations

NC	1	8	VSS
VDD	2	7	VSS
XL5003			
IS	3	6	VIN
SW	4	5	VIN

Figure2. Pin Configuration of XL5003 (Top View)

Table 1 Pin Description

Pin Number	Pin Name	Description
1	NC	No Connected.
2	VDD	The chip supply voltage.
3	IS	Current Sense Pin. (The current sense voltage is 0.2V)
4	SW	Output Switching Pin
5, 6	VIN	Input high voltage Pin. (Operation voltage 100V~400V)
7, 8	VSS	The chip reference ground.



Function Block

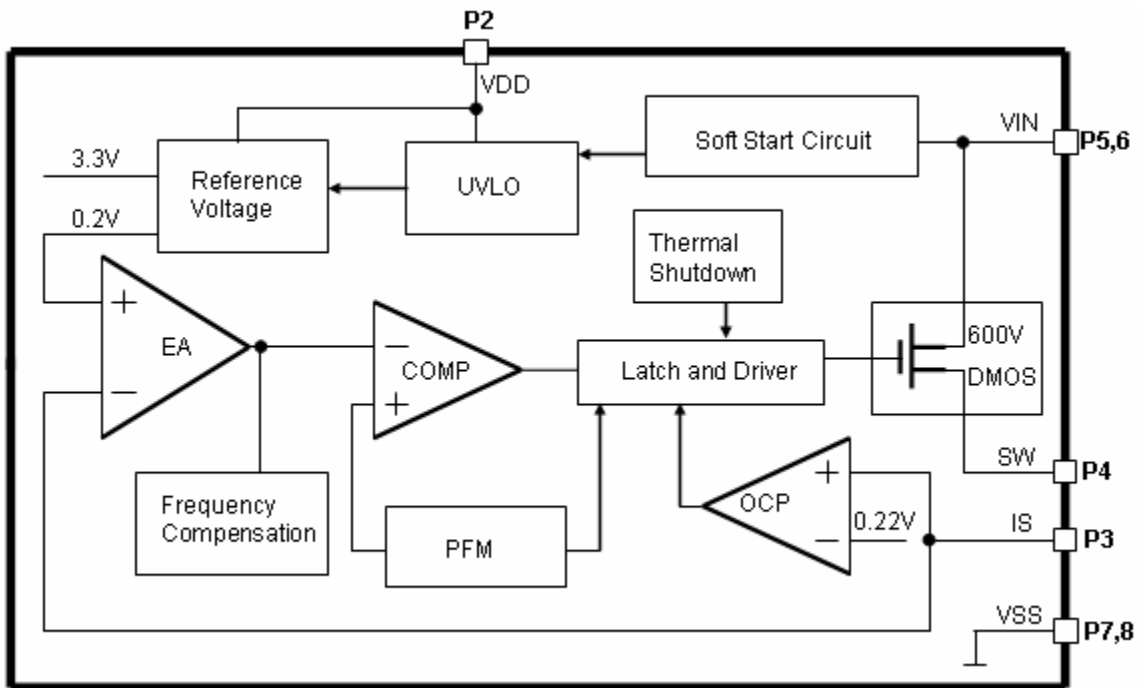
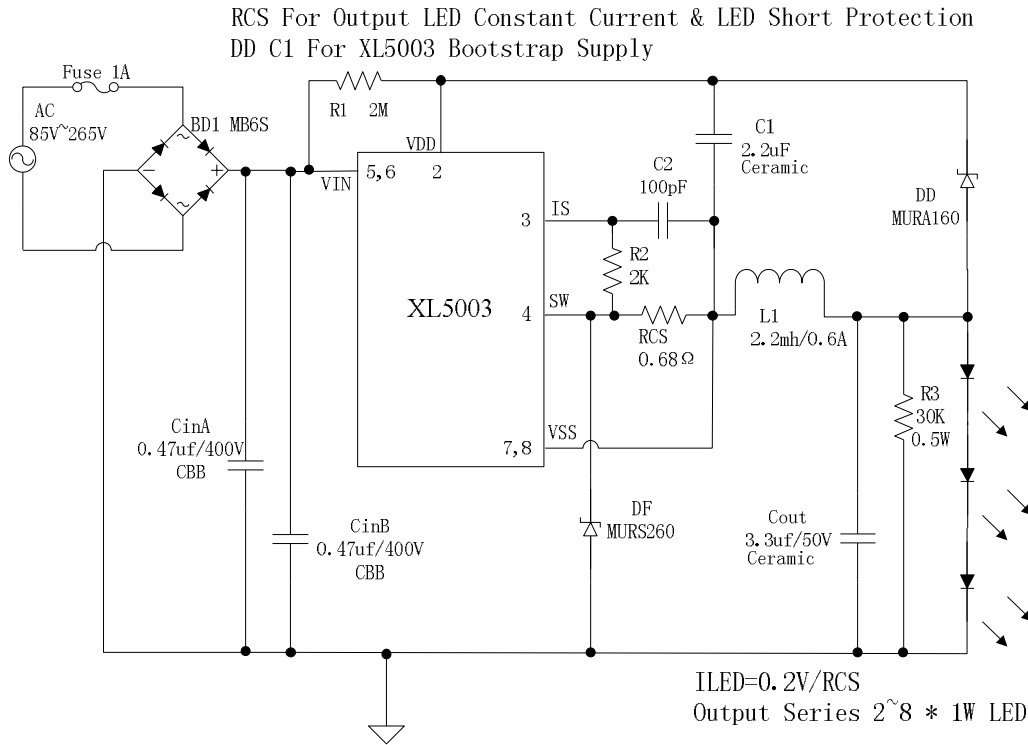

Figure3. Function Block Diagram of XL5003

Typical application circuit



- [1] Input AC 85V~265V Mains Supply.
- [2] Output Constant Current Drive Series 2~8 * 1W LED.
- [3] Support Output LED Open & Short Protection.
- [4] Support Without Electrolytic Capacitor Solution
For High Reliability & High Performance.

Figure4. XL5003 Typical Application (Mains supply 2W~8W LED saving energy lamp)

600V 0.5A Switching Current Buck PFM LED Constant Current Driver	XL5003
---	---------------

Ordering Information

Package	Temperature Range	Part Number	Marking ID	Packing Type
		Lead Free	Lead Free	
		XL5003E1	XL5003E1	Tube
		XL5003TRE1	XL5003E1	Tape & Reel

XLSEMI Pb-free products, as designated with “E1” suffix in the par number, are RoHS compliant.

Absolute Maximum Ratings (Note1)

Parameter	Symbol	Value	Unit
Input Voltage	V_{in}	-0.3 to 600	V
Power Dissipation	P_D	Internally limited	mW
Thermal Resistance (SOP-8L) (Junction to Ambient, No Heatsink, Free Air)	R_{JA}	100	°C/W
Operating Junction Temperature	T_J	-40 to 125	°C
Storage Temperature	T_{STG}	-65 to 150	°C
Lead Temperature (Soldering, 10 sec)	T_{LEAD}	260	°C
ESD (HBM)		3000	V

Note1: Stresses greater than those listed under Maximum Ratings may cause permanent damage to the device. This is a stress rating only and functional operation of the device at these or any other conditions above those indicated in the operation is not implied. Exposure to absolute maximum rating conditions for extended periods may affect reliability.

600V 0.5A Switching Current Buck PFM LED Constant Current Driver

XL5003

XL5003 Electrical Characteristics

T_a = 25°C; unless otherwise specified. Reference test circuit figure4

Symbol	Parameter	Test Condition	Min.	Typ.	Max.	Unit
VIS	IS Voltage	VAC = 220V, Iled=0.3A, Pout=2W ~ 8W	190	200	210	mV
Efficiency	η	VAC=110V, Iled=0.3A, Pout=8W	-	80.76	-	%
Efficiency	η	VAC=220V, Iled=0.3A, Pout=8W	-	76.63	-	%

Electrical Characteristics (DC Parameters)

Parameters	Symbol	Test Condition	Min.	Typ.	Max.	Unit
Input operation voltage	VIN		100		400	V
Quiescent Supply Current	I _q	Figure4, VAC=220V Iled=0		0.15	0.3	mA
Switching Frequency	Fosc	Figure4 (6*1W) VAC=220V	32	40	48	KHz
Max. Duty Cycle	D _{MAX}			25		%
VDMOS Drain-Source Breakdown Voltage	V _{BRDS}	V _{GS} =0V, I _{DS} =250uA	600			V
VDMOS Drain-Source on resistor	R _{DS(on)}	I _{DS} =0.5A, V _{GS} =10V		8	10	Ohm
Thermal Shutdown	OTP	T _j		165		°C
Thermal Shutdown Window				25		°C

600V 0.5A Switching Current Buck PFM LED Constant Current Driver

XL5003

[1] Typical application circuit without electrolytic capacitor (2W ~ 8W)

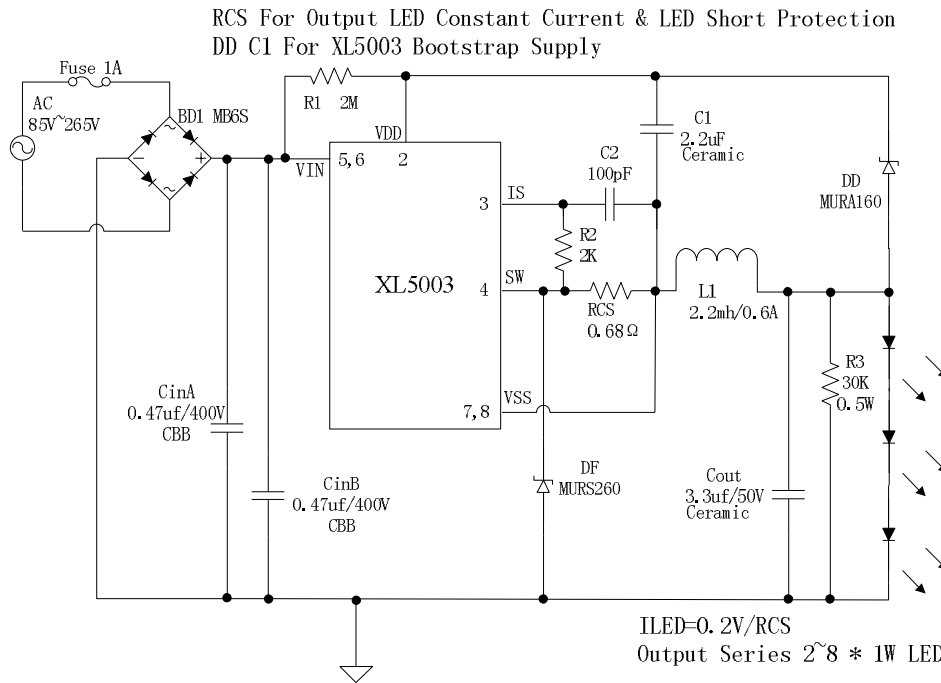

- [1] Input AC 85V~265V Mains Supply.
- [2] Output Constant Current Drive Series 2~8 * 1W LED.
- [3] Support Output LED Open & Short Protection.
- [4] Support Without Electrolytic Capacitor Solution For High Reliability & High Performance.

Figure5. XL5003 System Application for AC LED LAMP (2W ~ 8W)

VIN=110Vac						
1W LED Series	Pin(W)	PF	Vout (V)	I out (mA)	Fosc(KHz)	EF(%)
2	3.0	0.400	6.51	285	19	61.85
3	4.0	0.449	9.76	282	25	68.81
4	5.0	0.520	12.97	278	30	72.11
5	5.9	0.569	16.16	273	35	74.77
6	6.7	0.598	19.43	268	40	77.72
7	7.5	0.635	22.59	264	45	79.52
8	8.3	0.672	25.78	260	50	80.76
VIN=220Vac						
1W LED Series	Pin(W)	PF	Vout (V)	I out (mA)	Fosc(KHz)	EF(%)
2	3.4	0.629	6.57	333	16	64.35
3	4.6	0.652	9.93	331	23	71.45
4	5.9	0.655	13.21	328	29	73.44
5	7.0	0.642	16.55	324	35	76.60
6	8.3	0.619	19.86	321	40	76.81
7	9.6	0.568	23.17	318	44	76.75
8	10.7	0.502	26.45	310	49	76.63

600V 0.5A Switching Current Buck PFM LED Constant Current Driver

XL5003

[2] Typical application circuit with electrolytic capacitor (2W ~ 8W)

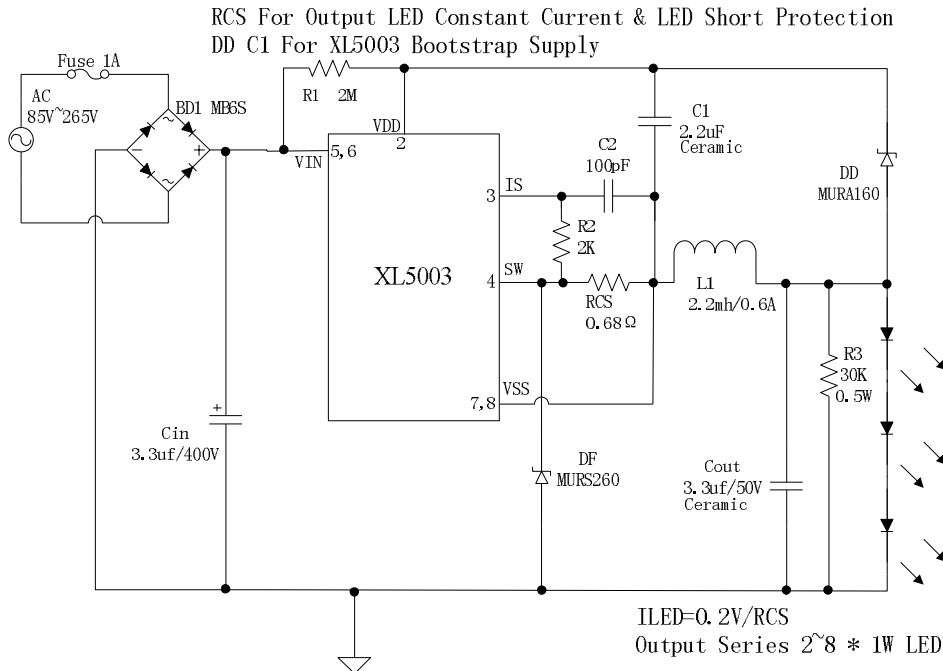

- [1] Input AC 85V~265V Mains Supply.
- [2] Output Constant Current Drive Series 2~8 * 1W LED.
- [3] Support Output LED Open & Short Protection.

Figure6. XL5003 System Application for AC LED LAMP (2W ~ 8W)

VIN=110Vac						
1W LED Series	Pin(W)	PF	Vout (V)	Iout (mA)	Fosc (KHz)	EF (%)
2	3.0	0.600	6.54	313	18	68.23
3	4.2	0.623	9.89	311	24	73.23
4	5.5	0.632	13.16	309	30	73.94
5	6.6	0.605	16.41	306	35	76.08
6	8.1	0.518	19.81	305	40	74.59
7	8.8	0.540	22.88	288	45	74.88
8	9.3	0.560	25.95	272	49	75.90
VIN=220Vac						
1W LED Series	Pin(W)	PF	Vout (V)	Iout (mA)	Fosc (KHz)	EF (%)
2	3.5	0.486	6.60	345	15	65.06
3	4.8	0.500	9.99	344	21	71.60
4	6.2	0.525	13.29	342	26	73.31
5	7.2	0.537	16.57	340	31	78.25
6	8.5	0.562	19.98	338	36	79.45
7	9.8	0.573	23.29	335	43	79.61
8	10.9	0.588	26.67	332	48	81.23

600V 0.5A Switching Current Buck PFM LED Constant Current Driver

XL5003

[3] Typical application circuit with PFC (2W ~ 8W)

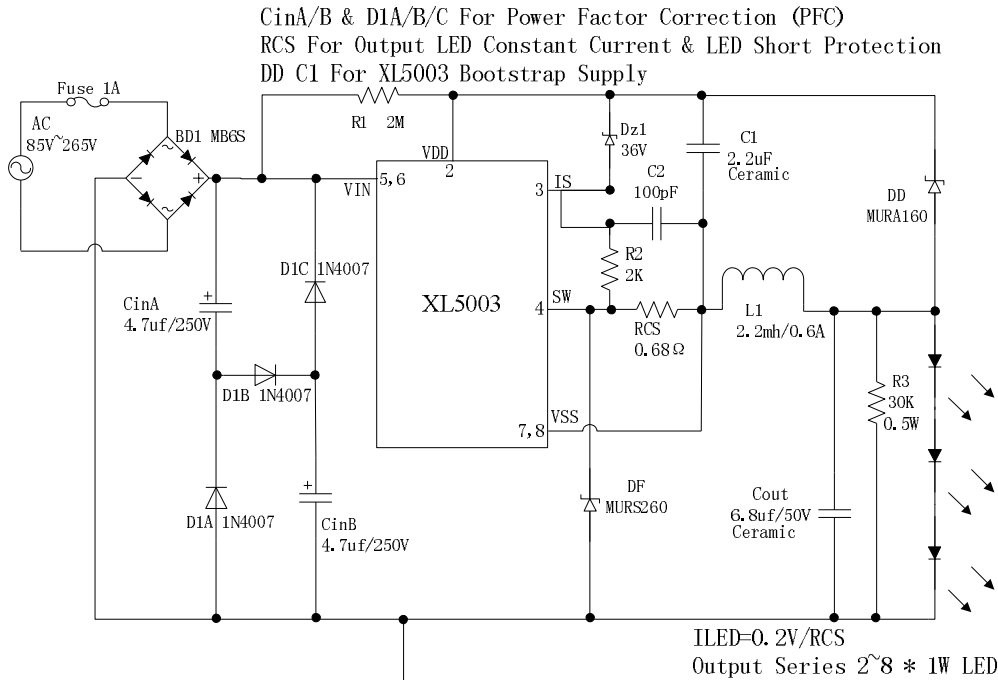

- [1] Input AC 85V~265V Mains Supply.
- [2] Output Constant Current Drive Series 2~8 * 1W LED.
- [3] Support Output LED Open & Short Protection.

Figure7. XL5003 System Application for AC LED LAMP (2W ~ 8W)

VIN=110Vac						
1W LED Series	Pin(W)	PF	Vout(V)	Iout(mA)	Fosc(KHz)	EF(%)
2	2.9	0.906	6.53	308	18	69.35
3	4.0	0.891	9.84	306	25	75.28
4	5.2	0.896	13.10	304	30	76.58
5	6.4	0.876	16.36	302	36	77.20
6	7.5	0.842	19.75	301	41	79.26
7	8.6	0.819	23.01	300	46	80.27
8	9.8	0.795	26.32	298	50	80.03
VIN=220Vac						
1W LED Series	Pin(W)	PF	Vout(V)	Iout(mA)	Fosc(KHz)	EF(%)
2	3.2	0.914	6.59	329	17	67.75
3	4.4	0.880	9.95	328	24	74.17
4	5.6	0.888	13.24	327	30	77.31
5	6.7	0.870	16.53	326	35	80.43
6	8.0	0.866	19.93	324	40	80.72
7	9.0	0.883	23.23	322	45	83.11
8	10.2	0.894	26.58	320	50	83.39

Package Information
SOP8 Package Mechanical Dimensions

SOIC-8

Unit: mm(inch)

