

Features

- n Operate from a rectified 85V~265V AC mains supply.
- n 0.1V current sense voltage reference.
- n Directly drive 1~5 series 1W LED.
- n Excellent line and load regulation.
- n Internal optimize power HV-MOSFET.
- n Built in thermal shutdown function.
- n Built in UVLO function.
- n Built in current limiting function.
- n Built in LED open & short protection.
- n Built in soft-start circuit.
- n Support without electrolytic capacitor System solution.
- n Available in SOIC-8 package.
- n $PF > 0.9$ (Power Factor) with suitable External components.

Applications

- n E27, GU10, GU5.3, B22 lamp device
- n LED Lighting & LED LAMP
- n General purpose lighting

General Description

The XL5006 is a monolithic high voltage switching regulator with PFM that is specifically designed to operate from a rectified 85V~265V AC mains supply.

The XL5006 is a high efficiency LED driver switching regulator. The LED string is driven at DC constant current rather than constant voltage, thus providing constant current output and enhanced reliability.



SOIC-8

Figure1. Package Type of XL5006

Pin Configurations

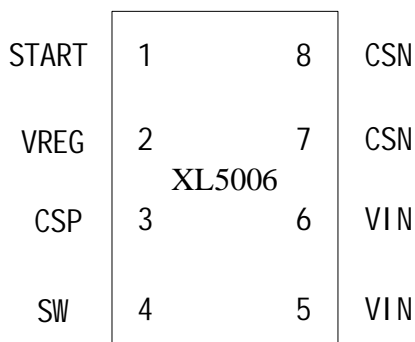

Figure2. Pin Configuration of XL5006 (Top View)

Table 1 Pin Description

Pin Number	Pin Name	Description
1	START	Internal start up Pin.
2	VREG	Internal Voltage Regulation Pin. (The VREG is about 8V)
3	CSP	Current Sense Positive Pin. (The current sense voltage is 0.1V)
4	SW	Output Switching Pin
5, 6	VIN	Input high voltage Pin. (Operation voltage 100V~400V)
7, 8	CSN	Current Sense Negative Pin.

600V 0.5A Switching Current Buck PFM LED Constant Current Driver XL5006

Function Block

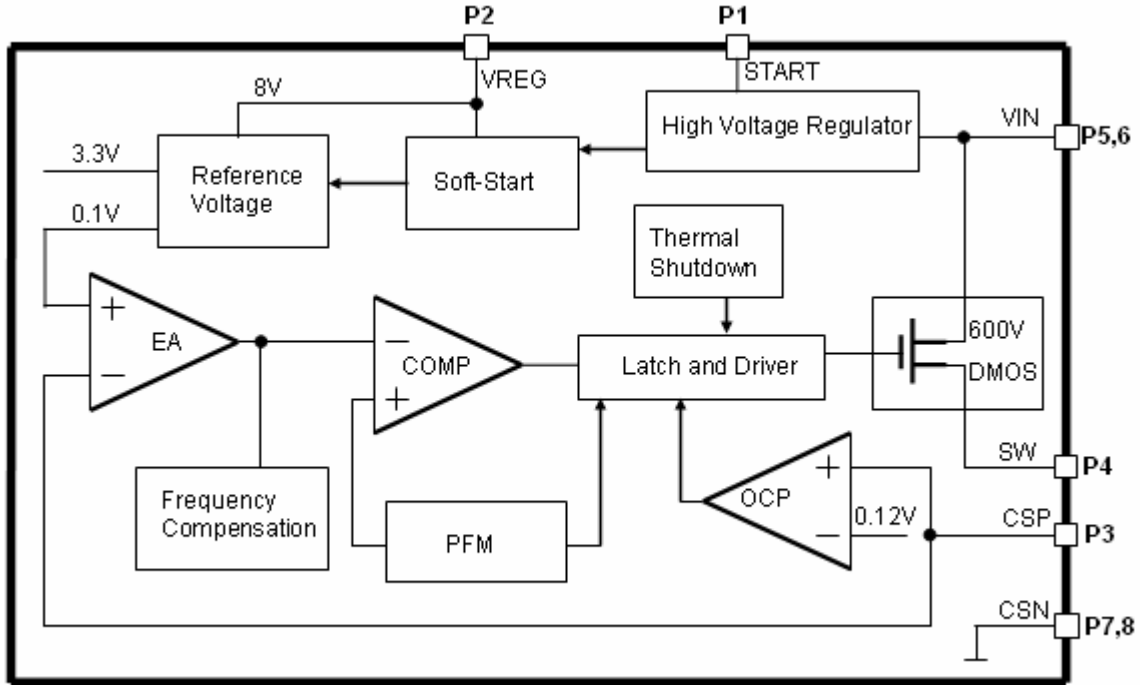

Figure3. Function Block Diagram of XL5006

Typical Application Circuit without electrolytic capacitor solution

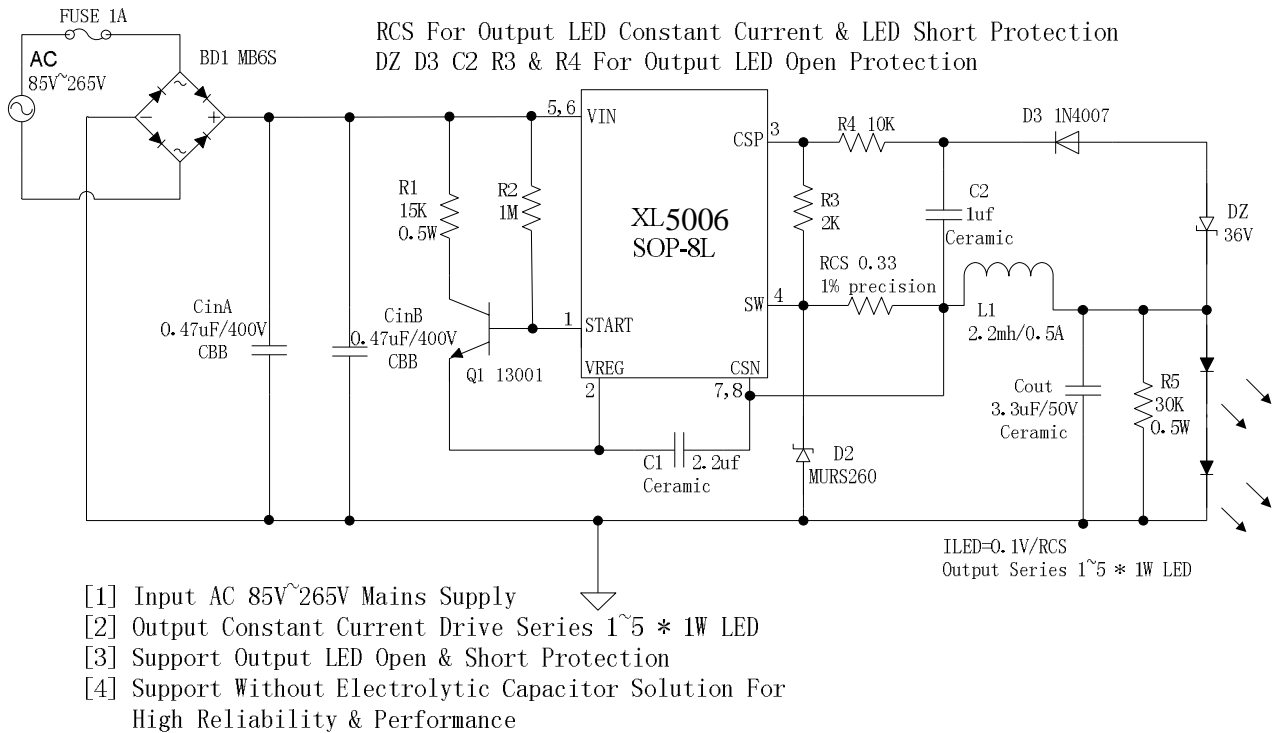

Figure4. XL5006 Typical Application (Mains supply 1~5W LED saving energy Lamp)

600V 0.5A Switching Current Buck PFM LED Constant Current Driver	XL5006
--	--------

Ordering Information

Package	Temperature Range	Part Number	Marking ID	Packing Type
		Lead Free	Lead Free	
		XL5006E1	XL5006E1	Tube
		XL5006TRE1	XL5006E1	Tape & Reel

XLSEMI Pb-free products, as designated with “E1” suffix in the par number, are RoHS compliant.

Absolute Maximum Ratings (Note1)

Parameter	Symbol	Value	Unit
Input Voltage	V _{in}	-0.3 to 600	V
Power Dissipation	P _D	Internally limited	mW
Thermal Resistance (SOP-8L) (Junction to Ambient, No Heatsink, Free Air)	R _{JA}	100	°C/W
Operating Junction Temperature	T _J	-40 to 125	°C
Storage Temperature	T _{STG}	-65 to 150	°C
Lead Temperature (Soldering, 10 sec)	T _{LEAD}	260	°C
ESD (HBM)		3000	V

Note1: Stresses greater than those listed under Maximum Ratings may cause permanent damage to the device. This is a stress rating only and functional operation of the device at these or any other conditions above those indicated in the operation is not implied. Exposure to absolute maximum rating conditions for extended periods may affect reliability.

600V 0.5A Switching Current Buck PFM LED Constant Current Driver

XL5006

XL5006 Electrical Characteristics

T_a = 25°C; unless otherwise specified. Reference test circuit figure6

Symbol	Parameter	Test Condition	Min.	Typ.	Max.	Unit
VCSP	CSP Voltage	VAC = 205V to 235V, Iled=0.3A	97	100	103	mV
VCSP	CSP Voltage	VAC = 85V to 265V, Iled=0.3A	94	100	106	mV
Efficiency	η	VAC=110V, Iled=0.3A, Pout=5W	-	79.42	-	%
Efficiency	η	VAC=220V, Iled=0.3A, Pout=5W	-	80.23	-	%

Electrical Characteristics (DC Parameters)

Parameters	Symbol	Test Condition	Min.	Typ.	Max.	Unit
Input operation voltage	VIN		100		400	V
Quiescent Supply Current	I _q	Figure4, VAC=220V Iled=0		0.15	0.3	mA
Switching Frequency	Fosc	Figure6 (3*1W) VAC=220V	18	22.5	27	KHz
Max. Duty Cycle	D _{MAX}			25		%
VDMOS Drain-Source Breakdown Voltage	V _{BRDS}	V _{GS} =0V, I _{DS} =250uA	600			V
VDMOS Drain-Source on resistor	R _{DS(on)}	I _{DS} =0.5A, V _{GS} =8V		8	10	Ohm
Thermal Shutdown	OTP	T _j		165		°C
Thermal Shutdown Window				25		°C

600V 0.5A Switching Current Buck PFM LED Constant Current Driver **XL5006**

[1] Typical Application Circuit without electrolytic capacitor solution

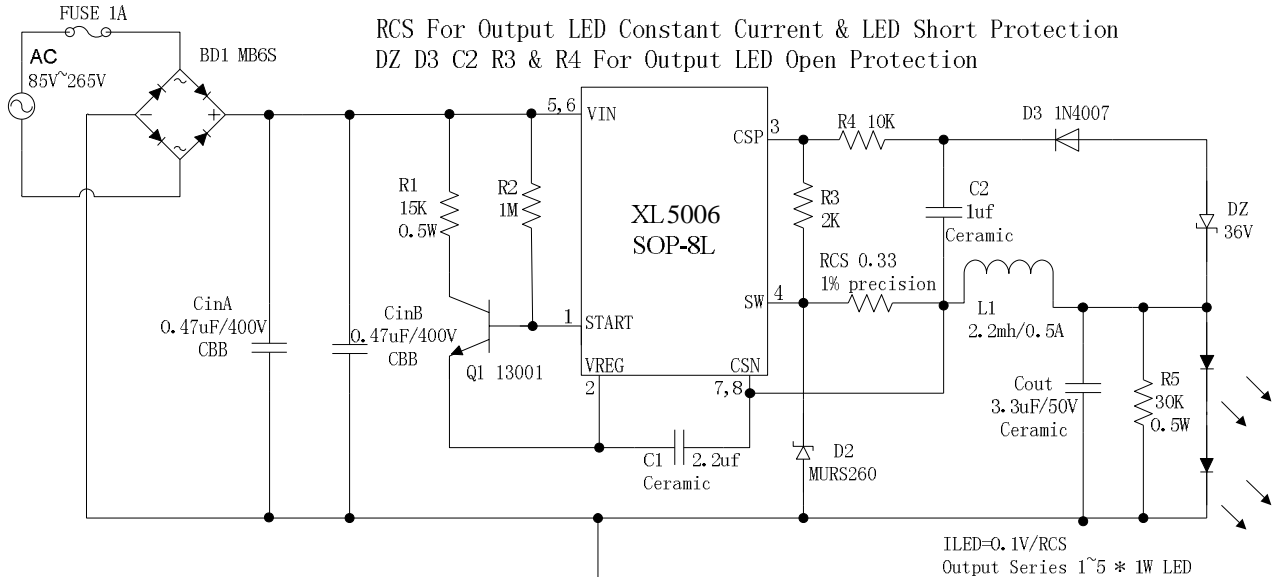

- [1] Input AC 85V~265V Mains Supply
- [2] Output Constant Current Drive Series 1~5 * 1W LED
- [3] Support Output LED Open & Short Protection
- [4] Support Without Electrolytic Capacitor Solution For High Reliability & Performance

Figure5. XL5006 System Application for AC LED LAMP (1W ~ 5W)

VIN=110Vac						
1W LED Series	Pin(W)	PF	Vout (V)	Iout (A)	Fosc(KHz)	EF (%)
1	1.9	0.612	3.48	0.310	13.2	56.8
2	3.1	0.402	6.77	0.292	21.7	63.8
3	4.1	0.465	10.05	0.289	28.4	70.8
4	5.3	0.546	13.91	0.284	35.7	74.5
5	6.2	0.590	17.20	0.280	42.3	77.7
VIN=220Vac						
1W LED Series	Pin(W)	PF	Vout (V)	Iout (A)	Fosc(KHz)	EF (%)
1	2.2	0.589	3.56	0.336	10.64	54.4
2	3.6	0.614	7.01	0.334	17.86	65.0
3	4.8	0.648	10.38	0.330	23.80	71.4
4	6.3	0.656	14.41	0.326	31.20	74.6
5	7.5	0.627	17.82	0.323	36.76	76.7

600V 0.5A Switching Current Buck PFM LED Constant Current Driver XL5006

[2] Typical System Application with PFC Function (1~5*1W with PFC)

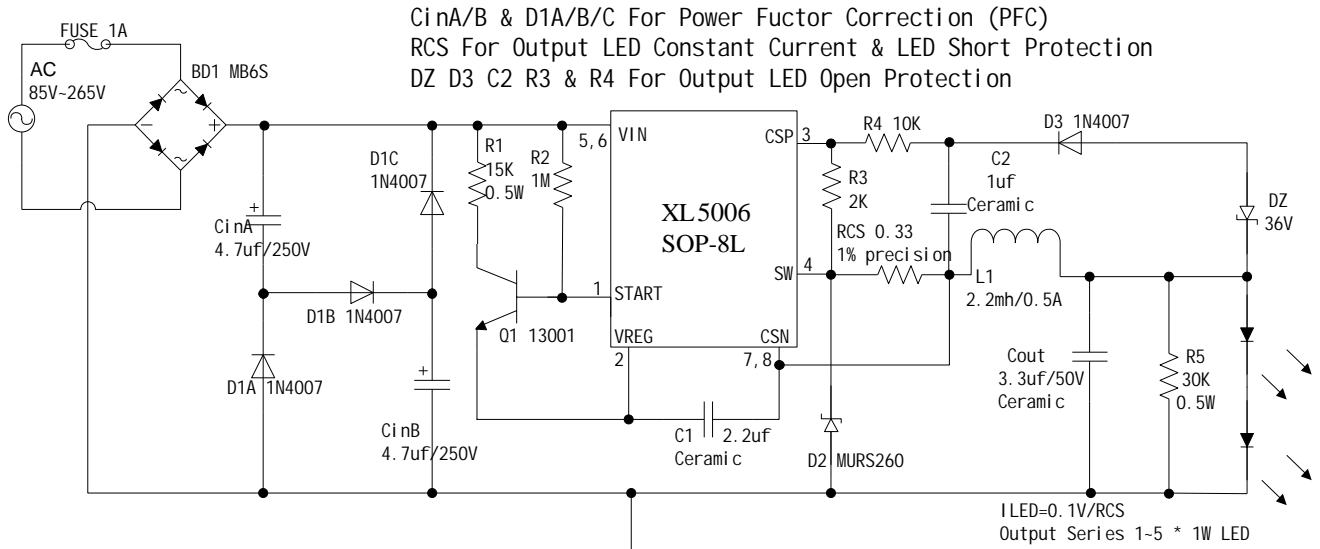

- [1] Input AC 85V~265V Mains Supply
- [2] Output Constant Current Drive Series 1-5 * 1W LED
- [3] Support Output LED Open & Short Protection

Figure6. XL5006 System Application for AC LED LAMP with PFC (1W ~ 5W)

VIN=110Vac						
1W LED Series	Pin(W)	PF	Vout (V)	Iout (A)	Fosc(KHz)	EF(%)
1	1.8	0.900	3.44	0.304	7.02	58.10
2	3.0	0.900	6.82	0.304	12.26	69.11
3	4.1	0.911	10.12	0.304	16.96	75.04
4	5.2	0.911	13.46	0.303	20.57	78.43
5	6.4	0.888	16.83	0.302	21.54	79.42
VIN=220Vac						
1W LED Series	Pin(W)	PF	Vout (V)	Iout (A)	Fosc(KHz)	EF(%)
1	2.0	0.909	3.49	0.319	10.49	55.67
2	3.3	0.909	6.89	0.319	16.72	66.60
3	4.4	0.880	10.23	0.318	22.52	73.94
4	5.6	0.888	13.61	0.317	28.24	77.04
5	6.7	0.881	17.01	0.316	33.58	80.23

600V 0.5A Switching Current Buck PFM LED Constant Current Driver XL5006

[3] Typical Application Circuit without electrolytic capacitor solution & with Linear Dimming Function

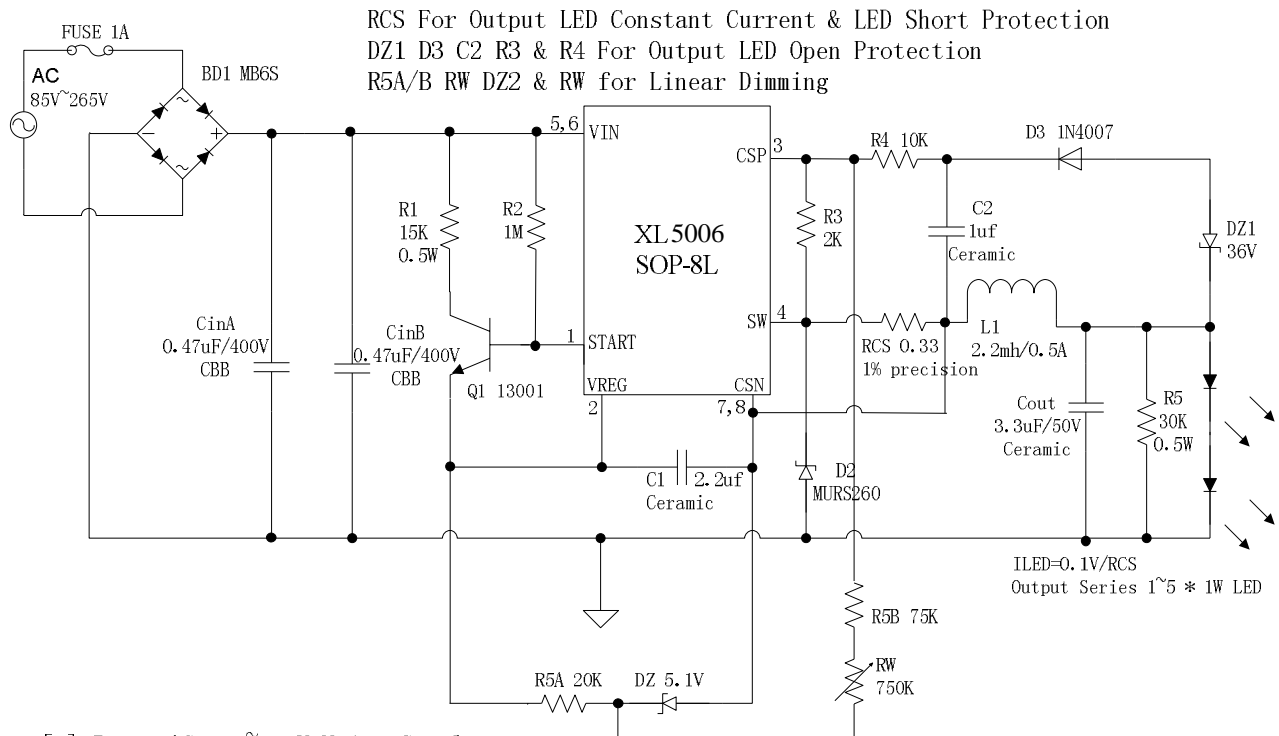

- [1] Input AC 85V~265V Mains Supply
- [2] Output Constant Current Drive Series 1~5 * 1W LED
- [3] Support Output LED Open & Short Protection
- [4] Support Without Electrolytic Capacitor Solution For High Reliability & Performance

Figure7. XL5006 System Application for AC LED LAMP with Dimming (1W ~ 5W)

