

Features

- Wide 5V to 65V Operation Voltage
- Output Adjustable from 1.25V to 25V
- Maximum Duty Cycle 100%
- Minimum Drop Out 1V
- Fixed 150KHz Switching Frequency
- Maximum 0.4A Output Current
- Recommend output power less than 5W
- Internal Optimize HV Power Transistor
- High efficiency up to 85%
- Excellent line and load regulation
- TTL shutdown capability
- Built in thermal shutdown function
- Built in output short Protection Function
- Built in current limit function
- SOP8-EP (Exposed PAD) package

Applications

- Ebike Controller Power Supply
- Telecom / Networking Equipment

General Description

The XL7005 is a 150KHz fixed frequency PWM buck (step-down) DC/DC converter, capable of driving a 0.4A load with high efficiency, low ripple and excellent line and load regulation. Requiring a minimum number of external components, the regulator is simple to use and include internal frequency compensation and a fixed-frequency oscillator.

The PWM control circuit is able to adjust the duty ratio linearly from 0 to 100%. An enable function, an over current protection function is built inside. When output short protection function happens, the operation frequency will be reduced from 150KHz to 45KHz. An internal compensation block is built in to minimize external component count.

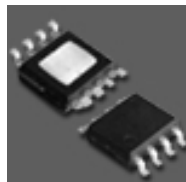

Figure1. Package Type of XL7005

Pin Configurations

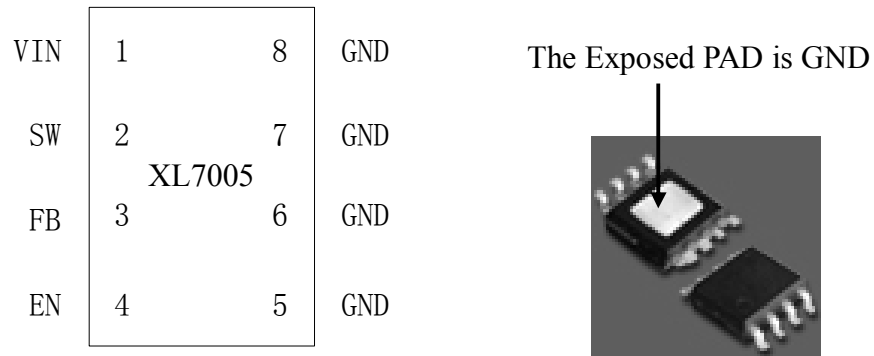

Figure2. Pin Configuration of XL7005 (Top View)

Table 1 Pin Description

Pin Number	Pin Name	Description
1	VIN	Supply Voltage Input Pin. XL7005 operates from a 5V to 65V DC voltage. Bypass Vin to GND with a suitably large capacitor to eliminate noise on the input.
2	SW	Power Switch Output Pin (SW). Output is the switch node that supplies power to the output.
5~8	GND	Ground Pin. Care must be taken in layout. This pin should be placed outside of the Schottky Diode to output capacitor ground path to prevent switching current spikes from inducing voltage noise into XL7005. The exposed PAD is GND.
3	FB	Feedback Pin (FB). Through an external resistor divider network, Feedback senses the output voltage and regulates it. The feedback threshold voltage is 1.25V.
4	EN	Enable Pin. Drive EN pin low to turn on the device, drive it high to turn it off. Floating is default low.

Function Block

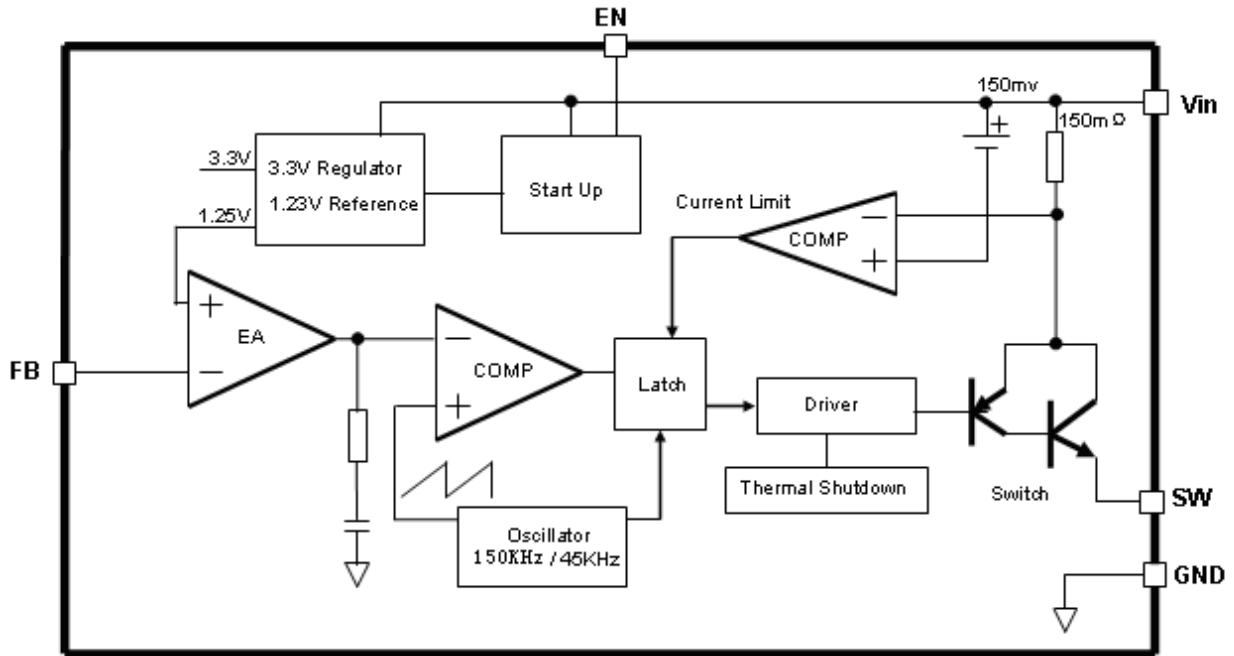

Figure3. Function Block Diagram of XL7005

Typical Application Circuit

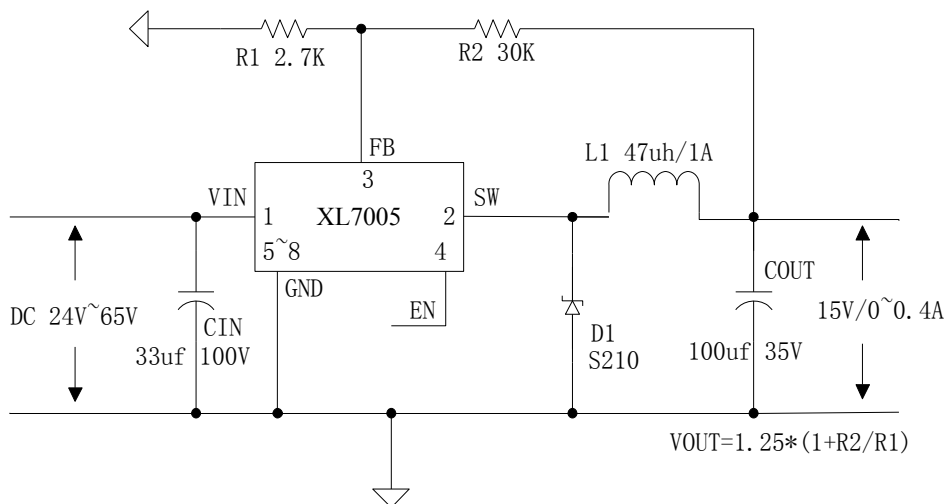

Figure4. XL7005 Typical Application Circuit

0.4A 150KHz 65V Buck DC to DC Converter

XL7005

Ordering Information

Order Information	Marking ID	Package Type	Packing Type Supplied As
XL7005E1	XL7005E1	SOP8-EP	2500 Units on Tape & Reel

XLSEMI Pb-free products, as designated with “E1” suffix in the par number, are RoHS compliant.

Absolute Maximum Ratings (Note1)

Parameter	Symbol	Value	Unit
Input Voltage	V_{in}	-0.3 to 70	V
Feedback Pin Voltage	V_{FB}	-0.3 to V_{in}	V
EN Pin Voltage	V_{EN}	-0.3 to V_{in}	V
Output Switch Pin Voltage	V_{SW}	-0.3 to V_{in}	V
Power Dissipation	P_D	Internally limited	mW
Thermal Resistance (SOP8-EP) (Junction to Ambient, No Heatsink, Free Air)	R_{JA}	60	°C/W
Operating Junction Temperature	T_J	-40 to 125	°C
Storage Temperature	T_{STG}	-65 to 150	°C
Lead Temperature (Soldering, 10 sec)	T_{LEAD}	260	°C
ESD (HBM)		>3000	V

Note1: Stresses greater than those listed under Maximum Ratings may cause permanent damage to the device. This is a stress rating only and functional operation of the device at these or any other conditions above those indicated in the operation is not implied. Exposure to absolute maximum rating conditions for extended periods may affect reliability.

0.4A 150KHz 65V Buck DC to DC Converter

XL7005

XL7005 Electrical Characteristics

$T_a = 25^\circ\text{C}$; unless otherwise specified.

Symbol	Parameter	Test Condition	Min.	Typ.	Max.	Unit
<i>System parameters test circuit figure4</i>						
VFB	FB Voltage	$V_{in} = 36\text{V to } 65\text{V}$ $I_{load} = 0.05\text{A to } 0.3\text{A}$	1.225	1.25	1.275	V
Efficiency	η	$V_{in} = 36\text{V}$, $V_{out} = 15\text{V}$ $I_{out} = 0.3\text{A}$	-	85	-	%
Efficiency	η	$V_{in} = 48\text{V}$, $V_{out} = 15\text{V}$ $I_{out} = 0.4\text{A}$	-	83	-	%
Efficiency	η	$V_{in} = 60\text{V}$, $V_{out} = 15\text{V}$ $I_{out} = 0.4\text{A}$	-	81	-	%

Electrical Characteristics (DC Parameters)

$V_{in} = 48\text{V}$, $GND = 0\text{V}$, V_{in} & GND parallel connect a $33\mu\text{f}/100\text{V}$ capacitor; $I_{out} = 0.2\text{A}$, $T_a = 25^\circ\text{C}$; the others floating unless otherwise specified.

Parameters	Symbol	Test Condition	Min.	Typ.	Max.	Unit
Input operation voltage	V_{in}		5		65	V
Shutdown Supply Current	I_{STBY}	$V_{EN} = 2\text{V}$		85	200	μA
Quiescent Supply Current	I_q	$V_{ON/OFF} = 0\text{V}$, $V_{FB} = V_{in}$		2.5	5	mA
Oscillator Frequency	F_{osc}		120	150	180	KHz
Switch Current Limit	I_L	$V_{FB} = 0$		0.4		A
EN Pin Threshold	V_{EN}	High (Regulator OFF) Low (Regulator ON)		1.6 0.8		V
EN Pin Input Leakage Current	I_H	$V_{EN} = 2.5\text{V (OFF)}$		6	20	μA
	I_L	$V_{EN} = 0.5\text{V (ON)}$		1	10	μA
Output Saturation Voltage	V_{CE}	$V_{FB} = 0\text{V}$ $I_{out} = 0.4\text{A}$		0.87		V
Max. Duty Cycle	D_{MAX}	$V_{FB} = 0\text{V}$		100		%

Typical System Application (VOUT=15V)

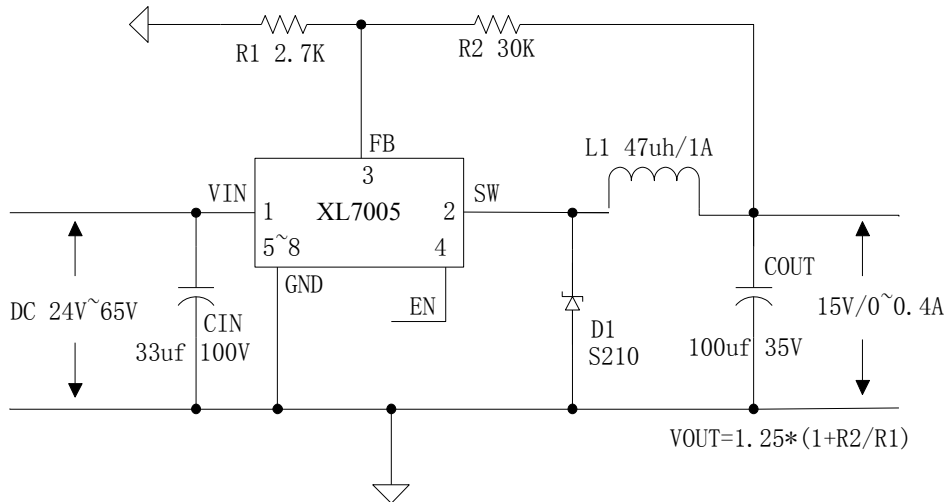

Figure5. XL7005 System Application (VIN=24V~65V, VOUT=15V)

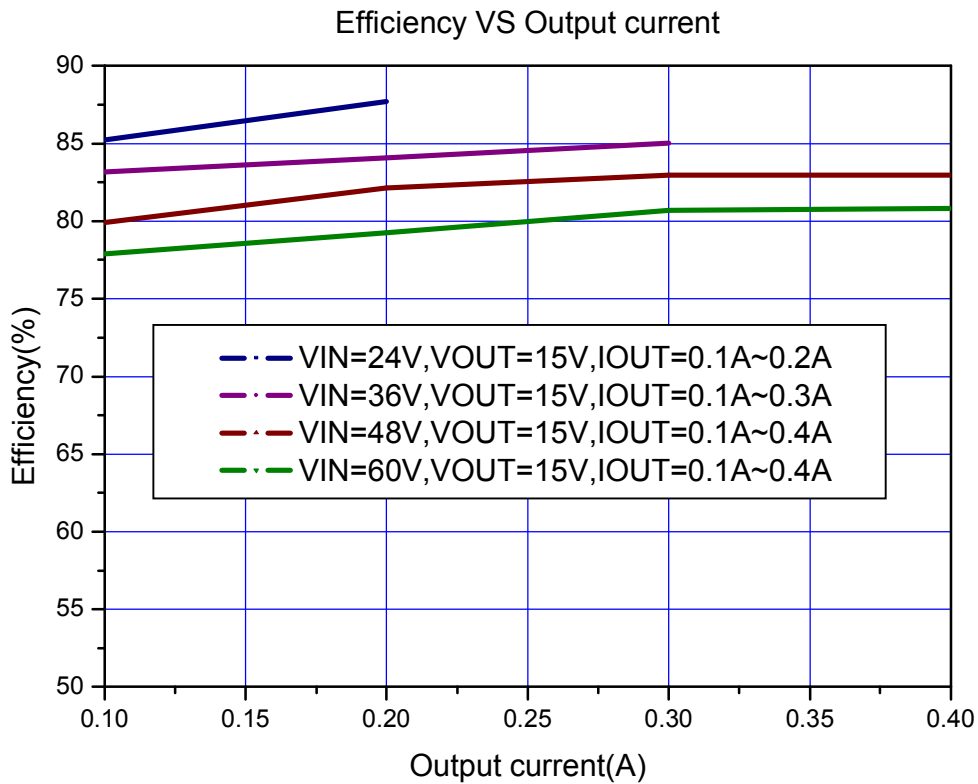

Figure6. XL7005 System Application (Efficiency VS Output Current)

Typical System Application (VOUT=5V)

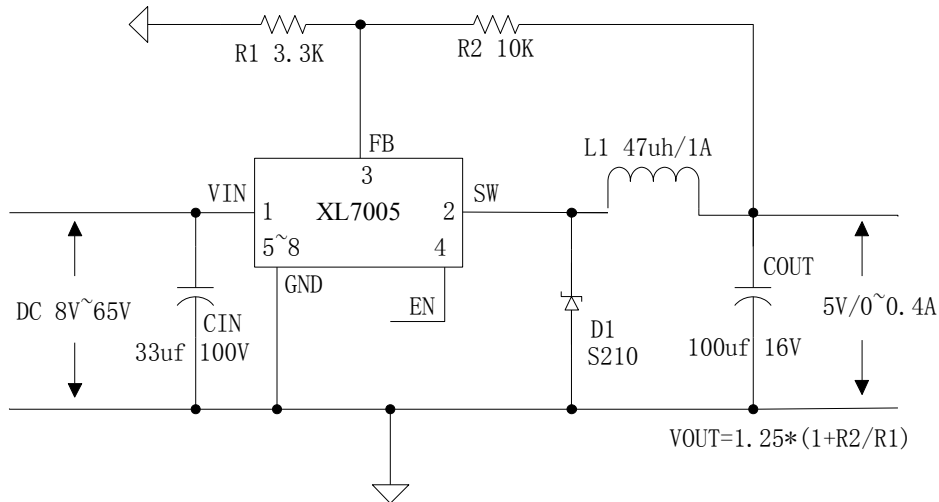

Figure7. XL7005 System Application (VIN=8V~65V, VOUT=5V)

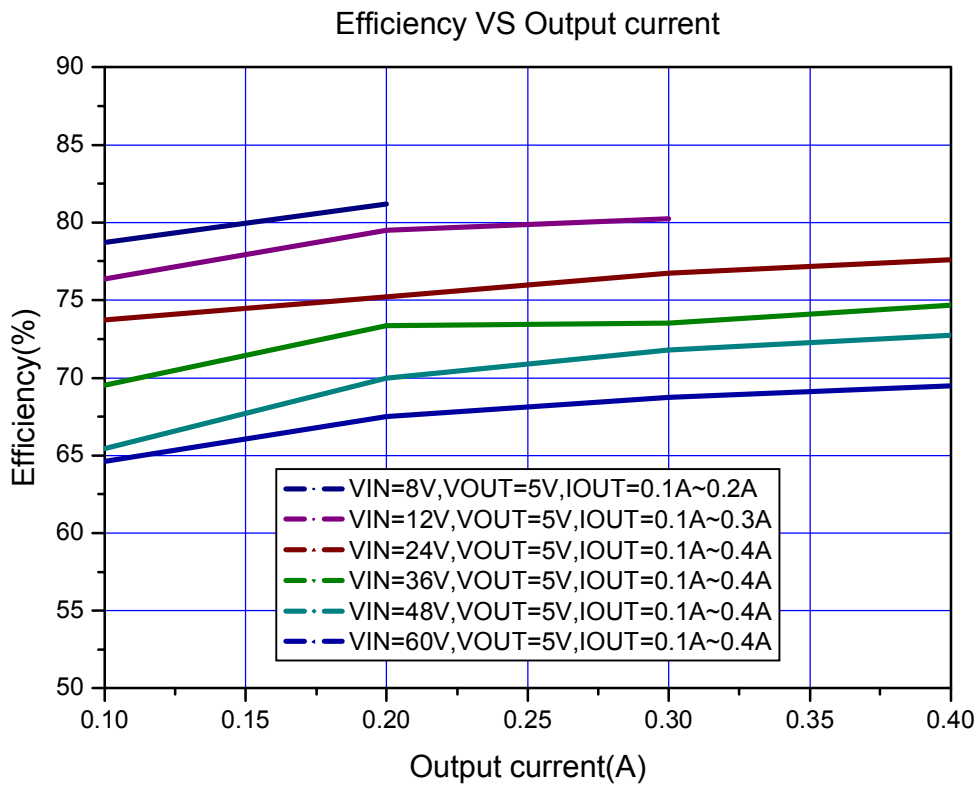
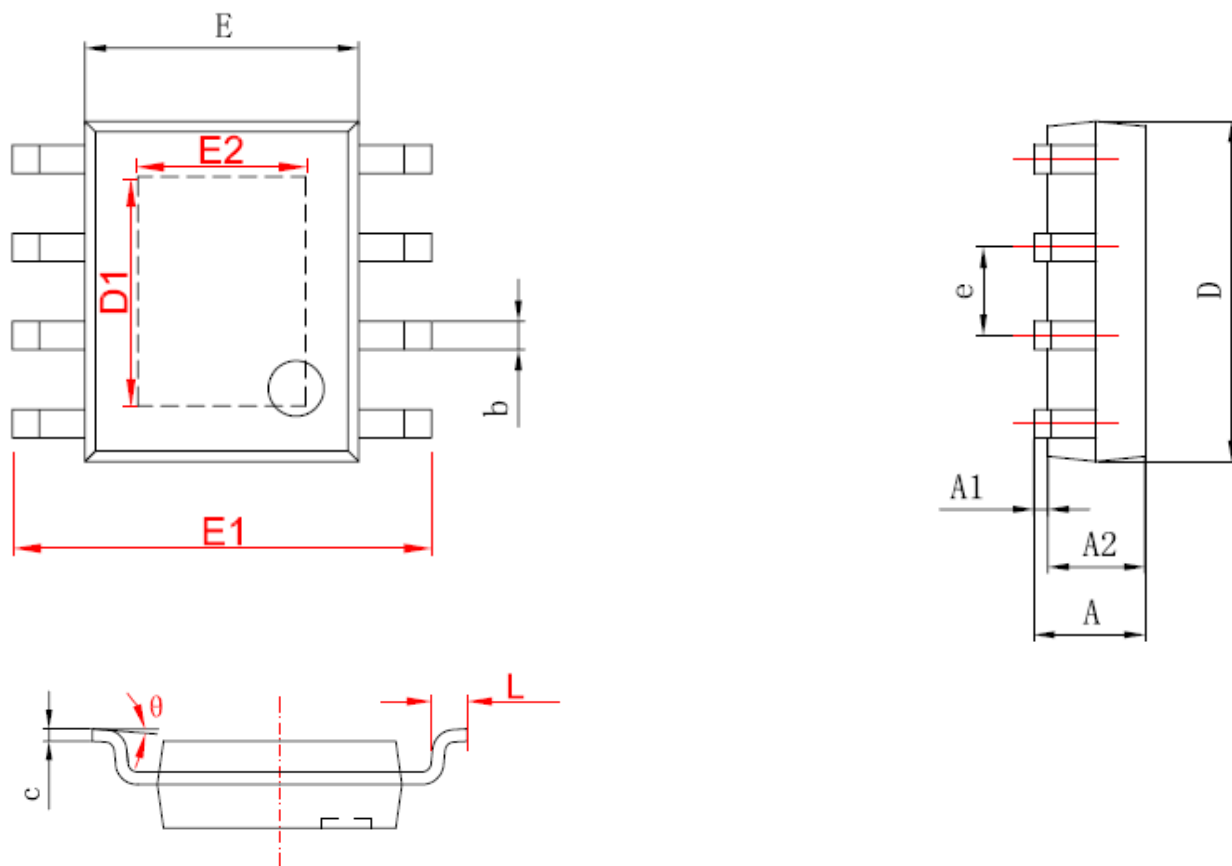

Figure8. XL7005 System Application (Efficiency VS Output Current)

Package Information

Package Information (SOP8-EP)



字符	Dimensions In Millimeters		Dimensions In Inches	
	Min	Max	Min	Max
A	1.350	1.750	0.053	0.069
A1	0.050	0.150	0.004	0.010
A2	1.350	1.550	0.053	0.061
b	0.330	0.510	0.013	0.020
c	0.170	0.250	0.006	0.010
D	4.700	5.100	0.185	0.200
D1	3.202	3.402	0.126	0.134
E	3.800	4.000	0.150	0.157
E1	5.800	6.200	0.228	0.244
E2	2.313	2.513	0.091	0.099
e	1.270 (BSC)		0.050 (BSC)	
L	0.400	1.270	0.016	0.050
θ	0°	8°	0°	8°