

1.2A Synchronous Step-Down DC/DC Converter

GENERAL DESCRIPTION

The XM5084 is a current mode synchronous step-down converter with fixed operating frequency and integrating PFM mode function. In light load condition, PFM function can increase the system efficiency and enhances the life of system power supply. The supply current is only 20uA at operating and less than 1uA at shutdown. This device is the ideally solution for Li-Ion battery powered system applications and small size board applications.

This device has internal switch, no external diode. It has internal fixed 1.5MHz frequency and makes application circuit smaller.

The XM5084 is available in an adjustable output voltage version. The adjustable version has wide output range from 0.6V to VIN. The XM5084 series products are available in a low profile (1mm) tiny SOT23-5 package.

FEATURES

- 1.2A Output Current
- High Efficiency up to 96%
- 2.5V to 5.5 V Input Range
- Adjustable Output Voltage from 0.6V to VIN
- Low Quiescent Current 20uA
- No Schottky Diode Required
- 1.5MHz Constant Frequency Operation
- Low Dropout Operation: 100% Duty Cycle
- Current Mode Operation for Excellent Line and Load Transient Response
- Operating Temperature: -40°C to +85°C
- Available in tiny SOT23-5 Package

Applications

- Mobile Phone/Smartphone
- DVB
- GPS
- FPGA Core Power Supply
- Communications

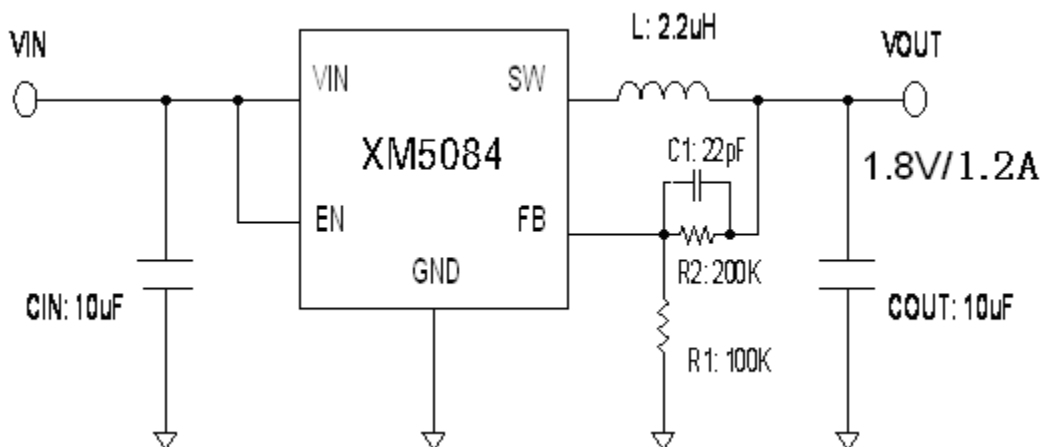

Figure 1. Typical Application Circuit

ORDERING INFORMATION

PART NUMBER	TEMP RANGE	SWICHING FREQUENCY	OUTPUT VOLTAGE (V)	OUTPUT CURRENT (A)	PACKAGE	PINS
XM5084_ADJ	-40°C to 85°C	1.5MHz	Adjustable	1.2	SOT23-5	5

PIN CONFIGURATION

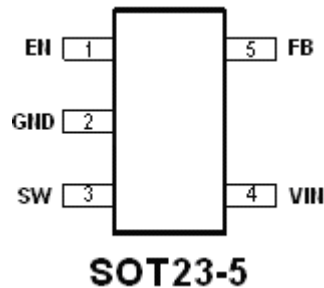

Figure 2. PIN Configuration

PIN DESCRIPTION

PIN NUMBER	PIN NAME	PIN DESCRIPTION
1	EN	Enable Input. When higher than 1.5V, this pin turns the IC on. When lower than 0.3V, this pin turns the IC off.
2	GND	Ground.
3	SW	Switch Output. Connect this pin to the inductor.
4	VIN	Power Supply.
5	FB	Feedback Input. The voltage at this pin is regulated to 0.6V. Connect to the resistor divider between output and ground to set output voltage.

ABSOLUTE MAXIMUM RATINGS

(Note: Do not exceed these limits to prevent damage to the device. Exposure to absolute maximum rating conditions for long periods may affect device reliability.)

PARAMETER	VALUE	UNIT
Supply Voltage VIN	-0.3 to 6.5	V
FB, EN Voltage	-0.3 to VIN+0.3	V
SW Voltage	-0.3 to VIN+0.3	V
Operating Ambient Temperature	-40 to 85	°C
Maximum Junction Temperature	125	°C
Storage Temperature	-55 to 150	°C

Lead Temperature (Soldering, 10 sec)	300	°C
--------------------------------------	-----	----

ELECTRICAL CHARACTERISTICS

($V_{IN} = 3.6V$, $T_A = 25^\circ C$ unless otherwise specified)

PARAMETER	SYMBOL	TEST CONDITIONS	MIN	TYP	MAX	UNIT
Input Voltage Range	V_{IN}		2.5		5.5	V
UVLO Threshold	V_{UVLO}	$V_{HYSTERESIS} = 100mV$	2.35	2.45	2.5	V
Operating Supply Current	I_{SUPPLY}	$V_{FB} = 0.5V$ or $V_{OUT} = 90\%$, $I_{Load} = 0$		130	170	μA
Standby Mode Supply Current		$V_{FB} = 0.62V$ or $V_{OUT} = 103\%$, $I_{Load} = 0$		20	35	
Shutdown Supply Current		$V_{EN} = 0V$, $V_{IN} = 4.2V$		0.1	1	
Regulated Feedback Voltage	V_{FB}	$T_a = 25^\circ C$	0.588	0.6	0.612	V
		$0 < T_a < 85^\circ C$	0.5865	0.6	0.6135	
		$-40^\circ C < T_a < 85^\circ C$	0.585	0.6	0.615	
Reference Voltage Line Regulation		$V_{IN} = 2.7V$ to $5.5V$		0.04	0.4	%
Regulated Output Voltage	V_{OUT}	$V_{OUT} = 1.8V$; $I_{OUT} = 100mA$	1.746	1.8	1.854	V
Output Voltage Load Regulation				0.5		%
Peak Inductor Current	I_{PEAK}	$V_{IN} = 3V$, $V_{FB} = 0.5V$ or $V_{OUT} = 90\%$, Duty Cycle $< 35\%$		2.1		A
Oscillator Frequency	F_{OSC}	$V_{FB} = 0.6V$ or $V_{OUT} = 100\%$	1.2	1.5	1.8	MHz
		$V_{FB} = 0$ or $V_{OUT} = 0$		220		KHz
Rds(ON) of P-channel FET		$I_{SW} = 100mA$		0.2	0.3	Ohm
Rds(ON) of N-channel FET		$I_{SW} = -100mA$		0.15	0.2	Ohm
Enable Threshold		$V_{IN} = 2.5V$ to $5.5V$	0.3	1	1.5	V
Enable Leakage Current			-0.1		0.1	μA
SW Leakage Current		$V_{EN} = 0V$, $V_{SW} = 0V$ or $5V$, $V_{IN} = 5V$	-1		1	μA

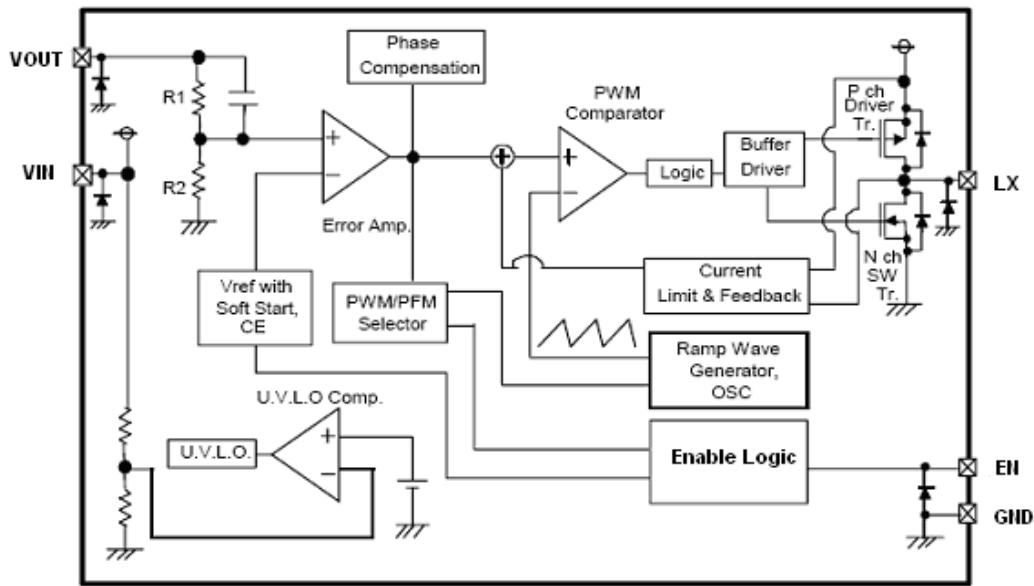

Figure 3. Functional Block Diagram

FUNCTIONAL DESCRIPTION

NORMAL OPERATION

In normal operation the high-side MOSFET turns on each cycle and remains on until the current comparator turns it off. At this point the low-side MOSFET turns on and remains on until either the end of the switching cycle or until the inductor current approaches zero. The error amplifier adjusts the current comparator's threshold as necessary in order to ensure that the output remains in regulation.

OVER CURRENT OPERATION

The part has internal current limit function, which is detected cycle by cycle. When its maximum inductor current limit is reached the charging cycle is terminated, and the low-side MOSFET is turned on to allow the inductor current to decrease. Under extreme overloads, such as short-circuit conditions, it reduces the oscillator frequency to 220KHz to allow further inductor current reduction and to minimize power dissipation.

APPLICATION INFORMATION

INDUCTOR SELECTION

In normal operation, the inductor maintains continuous current to the output. The inductor current has a ripple that is dependent on the inductance value. The high inductance reduces the ripple current. In general, select the inductance by the following equation:

$$L = \frac{V_{OUT} \times (V_{IN} - V_{OUT})}{V_{IN} \cdot f \cdot \Delta I}$$

Where V_{OUT} is the output voltage, V_{IN} is the input voltage, f is the switch frequency, and ΔI is the peak-to-peak inductor ripple current. Typically, choose ΔI as the 30% of the maximum output current.

Manufacturer	Part Number	Inductance(uH)	DRC max (Ohms)	Dimensions L*W*H(mm3)
Murata	LQH32PN	1	0.06	3.2*2.5*1.7
		2.2	0.09	
		4.7	0.15	
Sumida	CDRH3D16	1.5	0.04	4*4*1.8
		2.2	0.07	
		3.3	0.11	
		4.7	0.16	

Table 1. Recommend Surface Mount Inductors

INPUT CAPACITOR SELECTION

The input capacitor reduces input voltage ripple to the converter, low ESR ceramic capacitor is highly recommended. For most applications, a 10uF capacitor is used. The input capacitor should be

placed as close as possible to VIN and GND.

OUTPUT CAPACITOR SELECTION

A low ESR output capacitor is required in order to maintain low output voltage ripple. In the case of ceramic output capacitors, capacitor ESR is very small and does not contribute to the ripple, so a lower capacitance value is acceptable when ceramic capacitors are used. A 10uF ceramic output capacitor is suitable for most applications.

OUTPUT VOLTAGE PROGRAMMING

In the adjustable version, the output voltage is set by a resistive divider according to the following equation:

$$R_2 = R_1 \times \left(\frac{V_{OUT}}{0.6} - 1 \right)$$

Typically choose R1=100K and determine R2 from the following equation:

Connect a small capacitor across R1 feed forward capacitance at the FB pin for better performance.

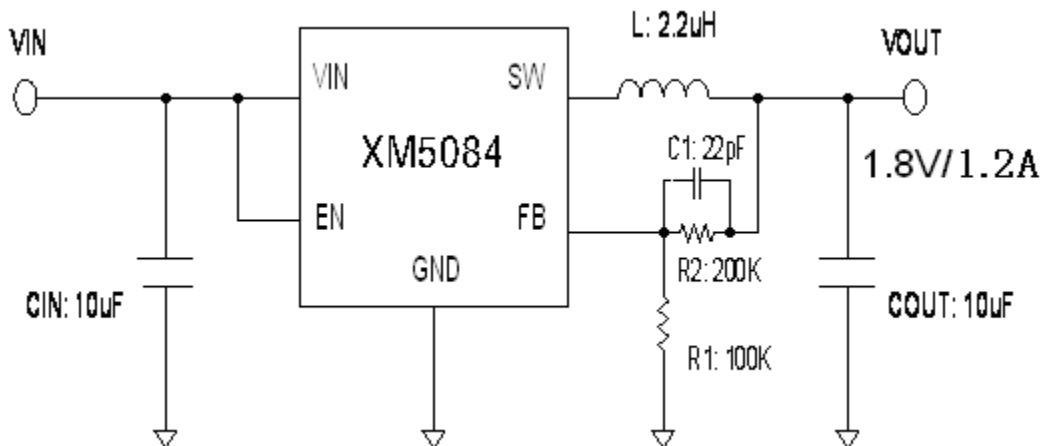
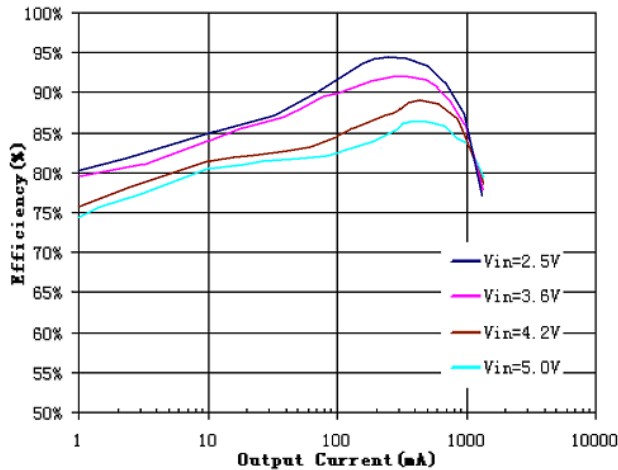

Figure 4. Typical Application Circuit for Adjustable Version

TYPICAL PERFORMANCE CHARACTERISTICS

(VIN=VEN=5V, L=2.2uH, CIN=10uF, COUT=10uF,if not mentioned)

Efficiency vs. Output Current (Vout=1.2V)



Oscillator Frequency vs. Temperature

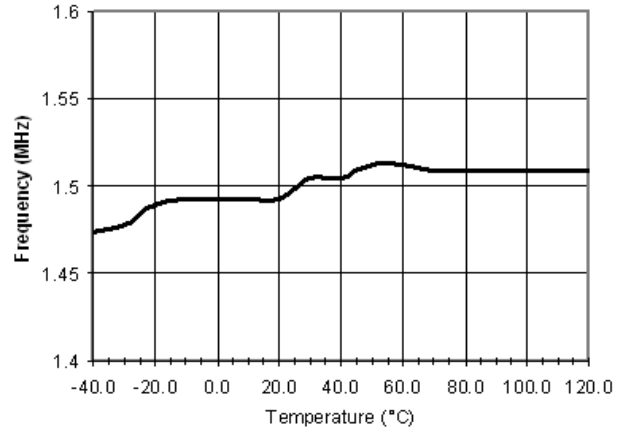

Efficiency vs. Output Current (Vout=1.8V)

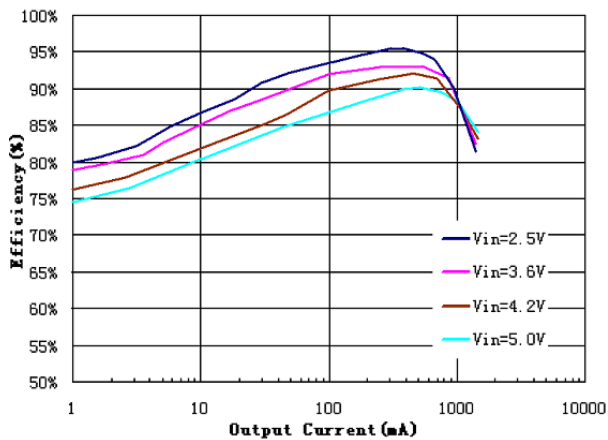

Reference Voltage vs. Temperature

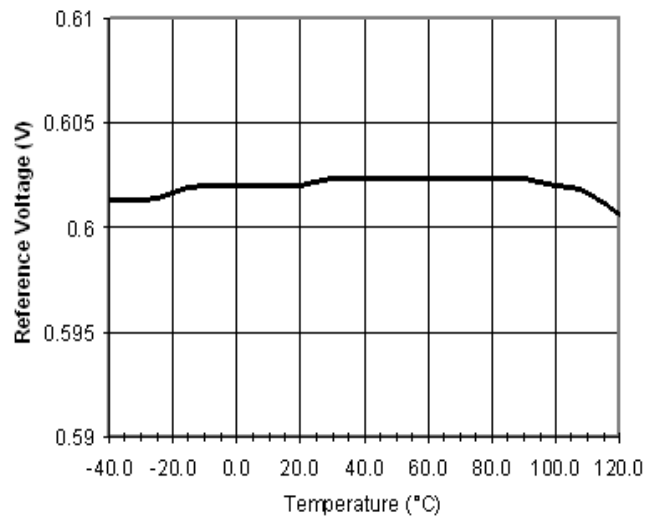

Efficiency vs. Output Current (Vout=3.3V)

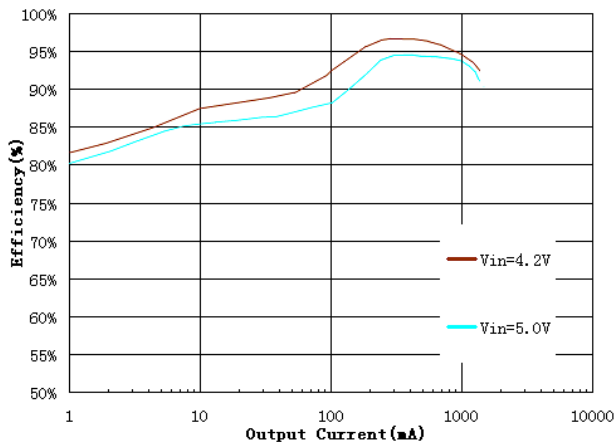

Steady State Waveform

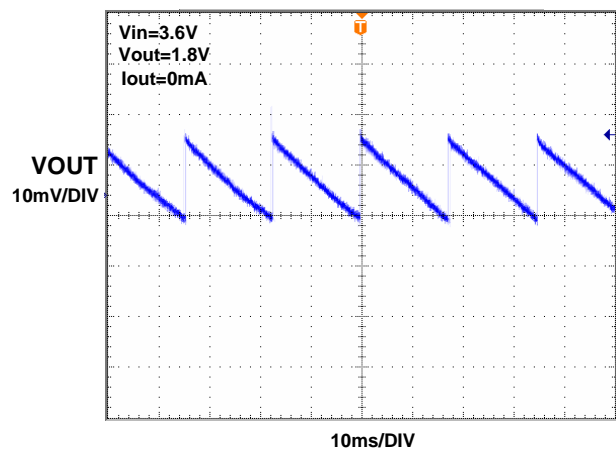

Steady State Waveform

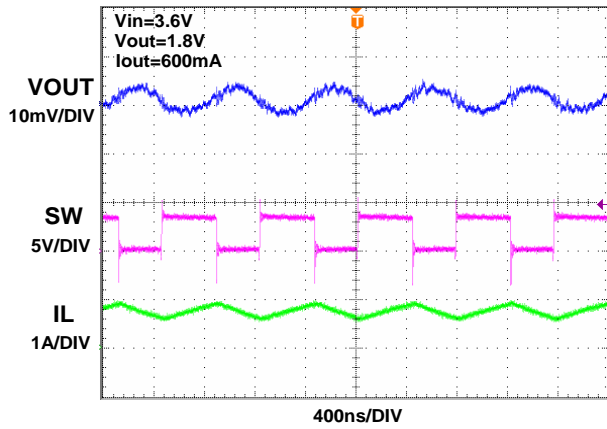

Load Transient Waveform

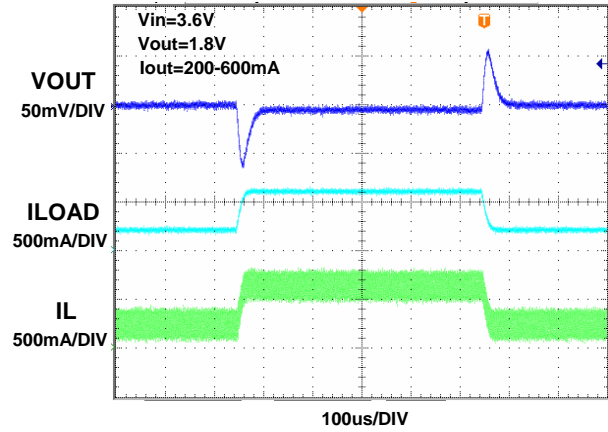

Steady State Waveform

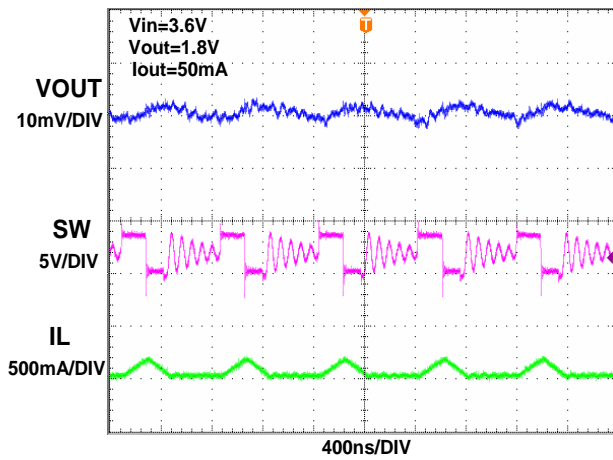

Startup through Enable Waveform

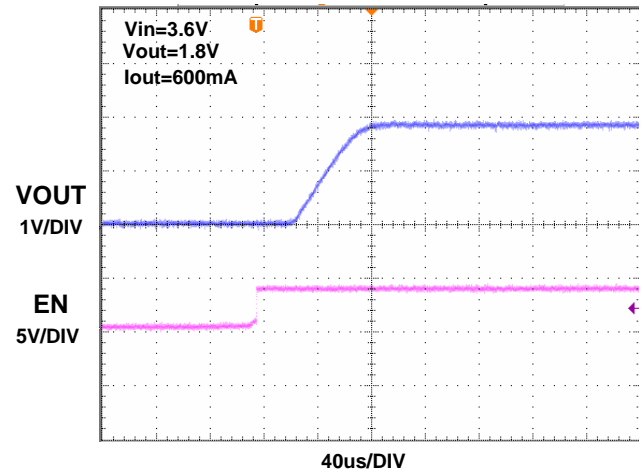

Load Transient Waveform

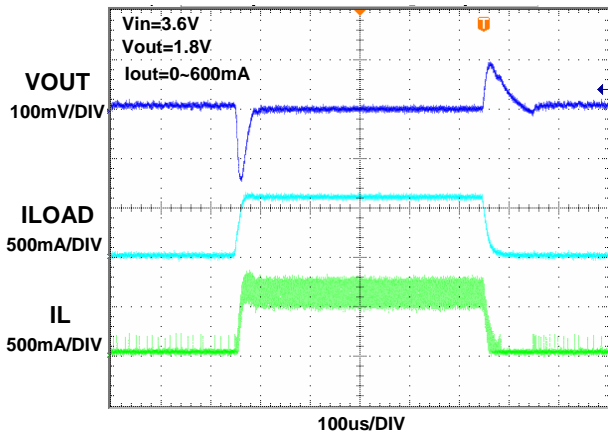

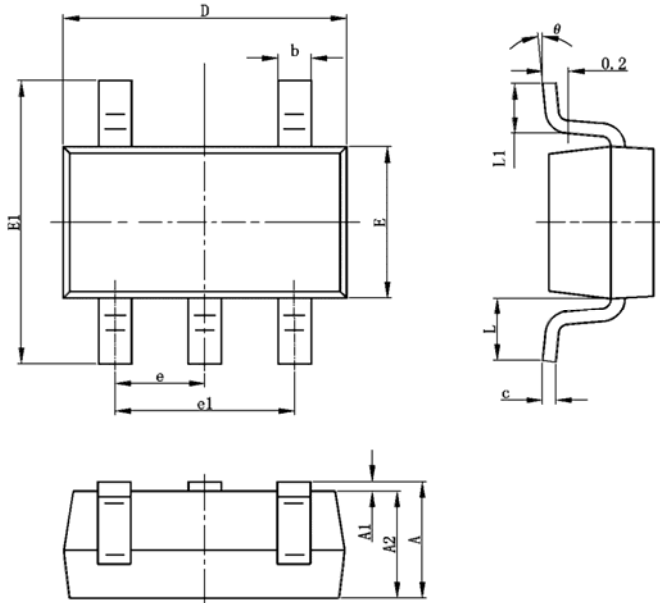
PACKAGE OUTLINE
SOT23-5 PACKAGE OUTLINE AND DIMENSIONS

SYMBOL	DIMENSION IN MILLIMETERS		DIMENSION IN INCHES	
	MIN	MAX	MIN	MAX
A	1.050	1.250	0.041	0.049
A1	0.000	0.100	0.000	0.004
A2	1.050	1.150	0.041	0.045
b	0.300	0.400	0.012	0.016
c	0.100	0.200	0.004	0.008
D	2.820	3.020	0.111	0.119
E	1.500	1.700	0.059	0.067
E1	2.650	2.950	0.104	0.116
e	0.950 TYP		0.037 TYP	
e1	1.800	2.000	0.071	0.079
L	0.700 REF		0.028 REF	
L1	0.300	0.600	0.012	0.024
θ	0°	8°	0°	8°