155 Mb/s Logic Interface Laser Transmitters for OC3/STM1

Technical Data

Features

- Full Compliance to SONET OC3 and SDH STM1
- -40°C to +85°C Operation
- Compact 20 Pin Package
- ECL/PECL Logic Interface
- Multisourced Pinout
- Fully Interchangeable Short and Long Reach Versions

Applications

- SONET/SDH Systems
- Single Mode ATM
- Fiber to the Home
- Data Communications Networks

Description

The XMT5360-155 and XMT5160-155 are high performance uncooled optical laser transmitters for CCITT SDH and ANSI SONET applications. They are designed with an ECL/PECL logic interface for 155 Mb/s transmission.

The transmitters incorporate several features which simplify system design. They may be operated with either +5 V or -5 V power supplies. Standard 10 KH ECL data interface enables direct interface with PECL or ECL logic. The compact transmitter module contains a pigtailed laser, data interface, bias and modulation control circuitry. Thus, no external components or adjustments are necessary. Finally, a laser disable input is provided to shut down the laser for standby or test purposes.

The two variants of the transmitter are for intermediate and long haul applications. The XMT5360-155 has -10 dBm mean output power for short and intermediate reach systems and the XMT5160-155 has -2.5 dBm mean output power for long haul systems. The two versions are fully interchangeable to allow a

XMT5360-155 XMT5160-155



single board design to be configured for short, intermediate, and long haul applications.

The XMT5360-155 and XMT5160-155 include analog outputs which are proportional to laser current and optical power. These may be used with external circuitry to detect end-of-life, or over temperature conditions. The transmitters are packaged in a 20 pin 0.4" pitch DIP. An evaluation board is available for this product. Contact your local representative for more details.

Connection Diagram

Top View

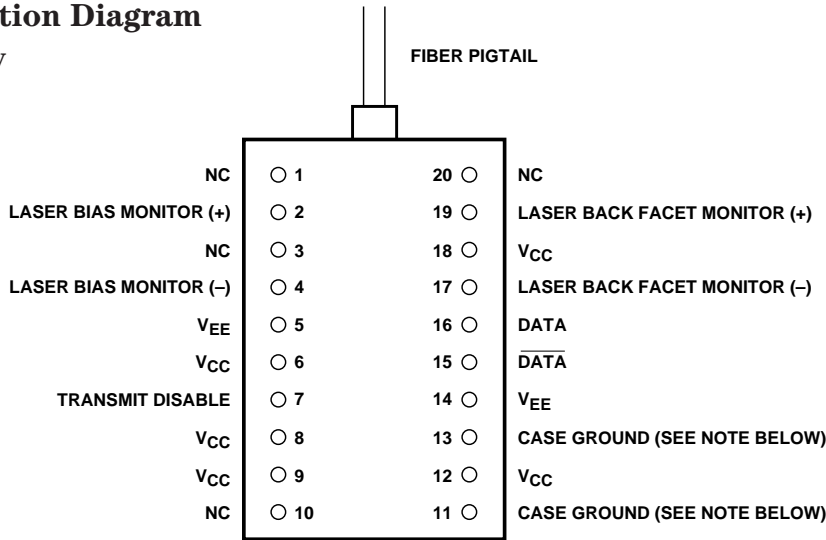

Pin Descriptions

Pins 1, 3, 10, 20, NC:

These pins should not be connected and should be left open circuit on the application PCB.

Pin 2, Laser Bias Monitor (+):

See Figure 1.

Pin 4, Laser Bias Monitor (-):

See Figure 1.

Pins 5, 14, V_{EE}:

These pins are connected to ground in +5 V systems and -5 V in negative supply systems.

Pins 6, 8, 9, 12, 18, V_{CC}:

These pins are connected to +5 V for positive supply systems and ground for -5.2 V systems.

Pin 7, Transmit Disable:

Pin 7 floats to V_{EE} when open circuited, enabling the transmitter. It must be biased within 3 V of V_{CC} to disable.

Pins 11, 13, Ground:

These pins connect to the case. They should always be connected to circuit ground.

Pins 15, 16, DATA, DATA:

These are differential ECL inputs. If open circuited they float to V_{BB} (V_{CC} - 1.3 V).

Pin 17, Laser Back Facet Monitor (-):

See Figure 2.

Pin 19, Laser Back Facet Monitor (+):

See Figure 2.

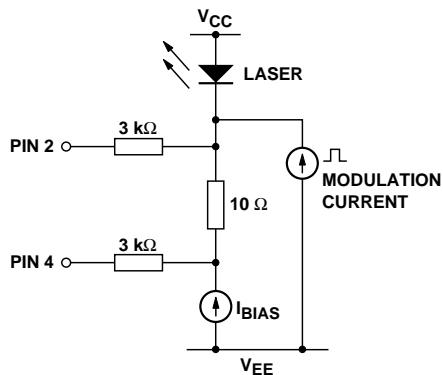

Figure 1. Laser Bias Monitor Circuitry.

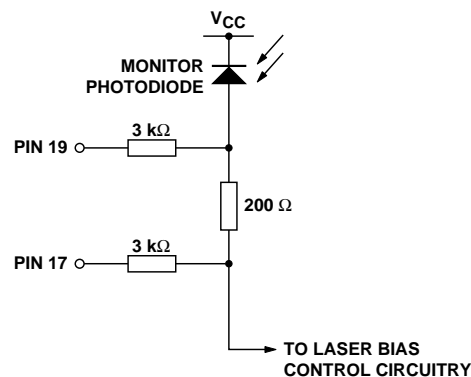
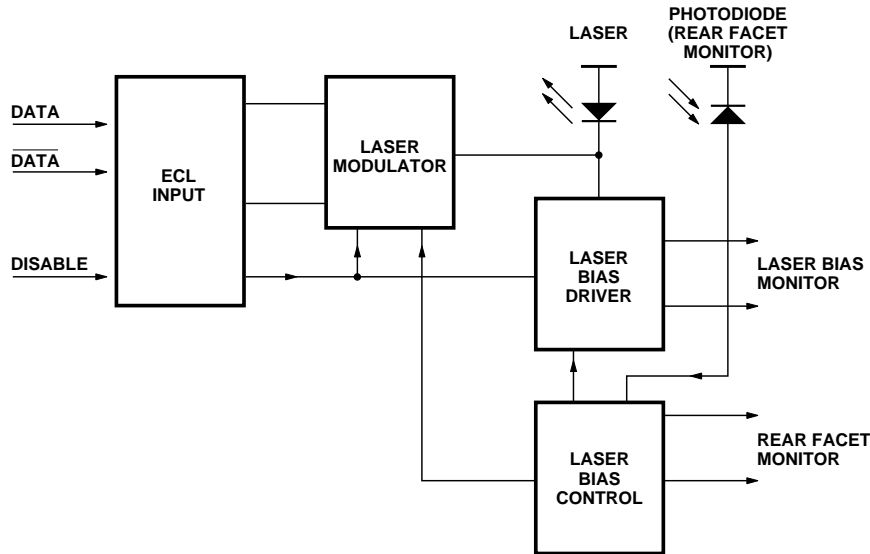

Figure 2. Back Facet Monitor Circuitry.

XMT5360-155 and XMT5160-155 Block Diagram



Functional Description

The ECL input allows operation from many logic families and both single-ended or differential signals. For single-ended operation both DATA and $\overline{\text{DATA}}$ are internally tied to a V_{BB} . The unused input then requires no connection or biasing.

The disable function disables the laser bias and modulator. The switching threshold is $V_{CC} - 3.2 \text{ V}$. If this input is not connected the module is enabled. This input may be connected to a CMOS HI or tied to V_{CC} to disable.

The module provides the necessary bias and modulation control to maintain the extinction ratio at better than 10:1 and the waveform is compliant with SONET/SDH Eyemask standard G.957.

The laser bias control loop compensates for temperature-induced variations in laser performance. The bias current monitor indicates the amount of dc current supplied to the laser. (This is approximately the laser threshold current).

The rear facet monitor is a signal proportional to the laser output power. This can be used as part of a HI/LO light alarm.

In the absence of data the laser will emit a mean optical power within the specified limits. The extinction ratio and duty cycle distortion are specified assuring a 50% duty cycle at the correct data rate.

Performance Specifications

Absolute Maximum Ratings

Parameter	Minimum	Nominal	Maximum	Units	Notes
Supply Voltage	-	-	7	V	-
Operating Case Temperature					
XMT5360A-155 and XMT5160A-155	-40	-	+85	°C	-
XMT5360B-155 and XMT5160B-155	0	-	+70	°C	-
Storage Temperature	-40	-	+85	°C	-
Fiber Tensile Strength	10	-	-	N/10s	1
Fiber Bend Radius	32	-	-	mm	-
Lead Soldering (Temperature/Time)	-	-	+260/10	°C/Sec	-

Characteristics

Parameter	Minimum	Nominal	Maximum	Units	Notes
Average Output Power					
XMT5360	-15	-10	-8	dBm	2
XMT5160	-5	-2.5	0	dBm	2
Center Wavelength					
XMT5360	1261	-	1360	nm	3
XMT5160	1280	-	1335	nm	3
Spectral Width (RMS)	-	-	4	nm	3
Rise Time (10% - 90%)	-	-	2	ns	-
Fall Time (10% - 90%)	-	-	2	ns	-
Extinction Ratio	10	-	-	dB	-
Bias Monitor	-	0.1	-	mA/mV	4
Rear Facet Monitor Output	5	-	50	mV	5
Supply Voltage	4.75	5.0	5.5	V	6
Supply Current	-	70	130	mA	7
Tx Disable	$V_{CC} - 3.2$	-	V_{CC}	V	-
Output Waveform	SONET/SDH Eyemask Compliant G.957				

Notes:

- In a coaxial direction with fiber feedthrough.
- Other output power options are available. Contact Hewlett-Packard for details.
- Over operating temperature range. A narrower operating temperature range will result in a smaller center wavelength spread. Contact Hewlett-Packard for details.
- Common mode signal $V_{EE} + 3.5$ V nominal.
- Common mode signal $V_{EE} + 1.2$ V nominal.
- With V_{EE} connected to -5 V, V_{CC} must be at 0 V. With V_{CC} at +5 V, V_{EE} must be at 0 V.
- End of life at T_{max} .

Drawing Dimensions

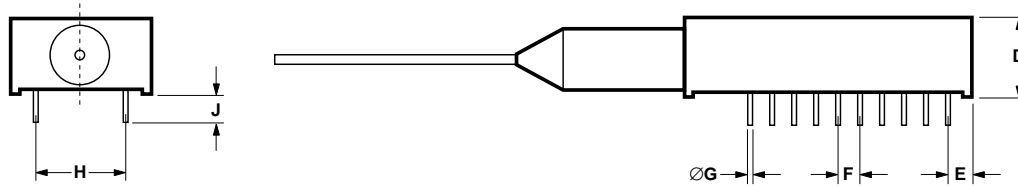
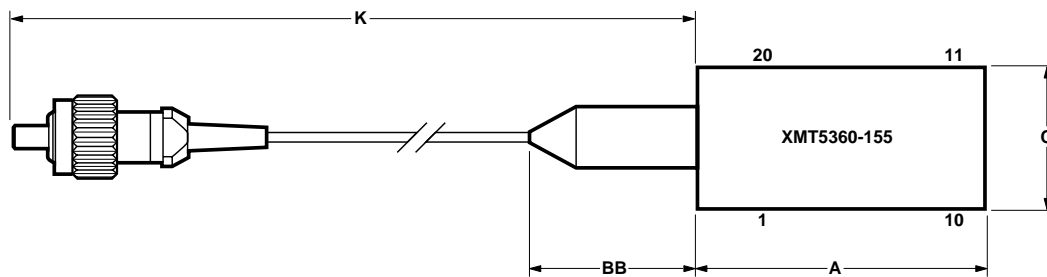
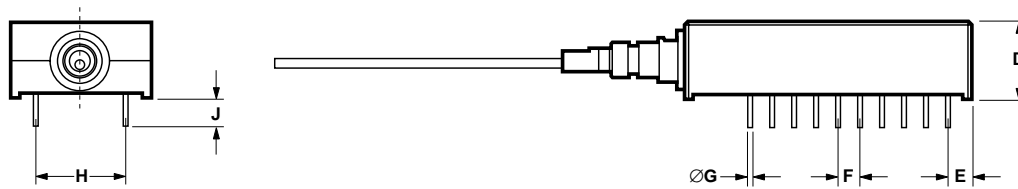
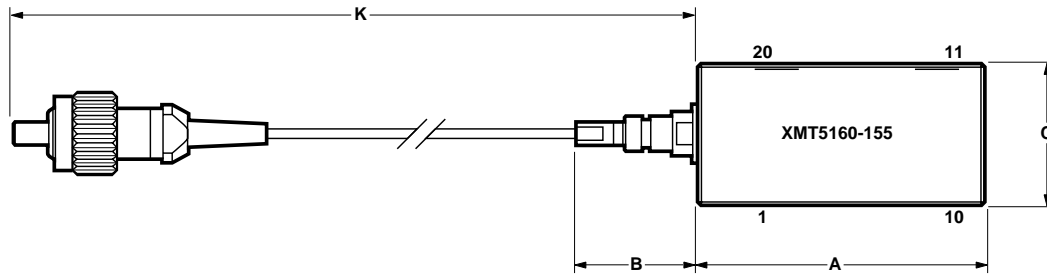

DIM.	MIN.	NOM.	MAX.
A	32.92	-	33.12
B	-	-	17.5
BB	-	-	24.0
C	16.03	-	16.23
D	-	-	9.27
E	2.64	-	2.9
F	-	2.54	-
ØG	-	0.46	-
H	-	10.16	-
J	-	3.3	-
K	400	-	1220

ALL DIMENSIONS IN MILLIMETERS

Ordering Information

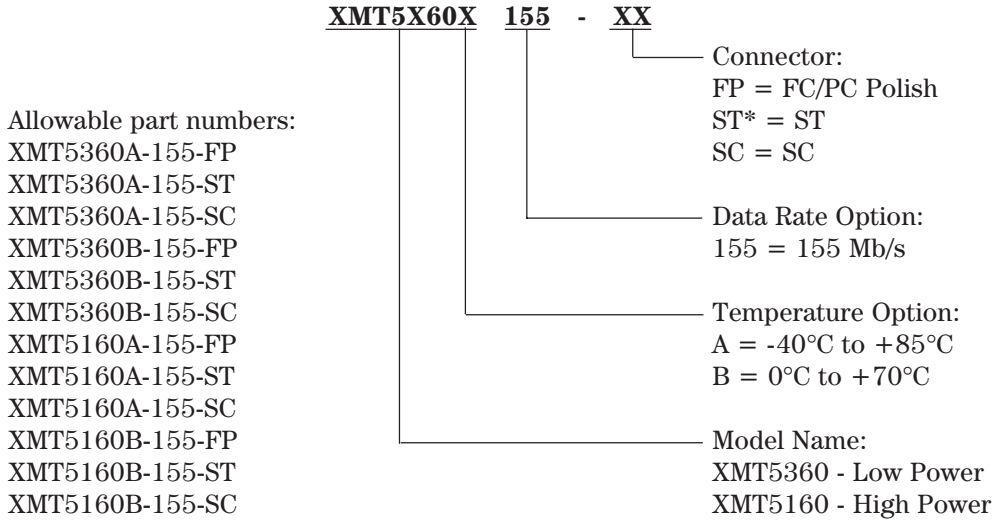

Class 1 Laser Product: This product conforms to the applicable requirements of 21 CFR 1040 at the date of manufacture.

Date of Manufacture: _____

Hewlett-Packard Ltd., Whitehouse Road, Ipswich, England

Handling Precautions

1. Normal handling precautions for electrostatic sensitive devices should be taken.
2. Semiconductor lasers can be damaged by overloading or by current surges. Appropriate transient protection should be taken.

*ST is a registered trademark of AT&T.