

Features

- 26 dB Small Signal Gain
- 39 dBm Third Order Intercept Point (OIP3)
- Integrated Power Detector
- Lead-Free 4 mm 24-lead QFN Package
- 100% RF Testing
- RoHS* Compliant and 260°C Reflow Compatible

Description

The XP1035-QH is a packaged linear power amplifier that operates over the 5.9-9.5 GHz frequency band. The device provides 26 dB gain and 39 dBm Output Third Order Intercept Point (OIP3) across the band and is offered in an industry standard, fully molded 4x4mm QFN package. The packaged amplifier is comprised of a three stage power amplifier with an integrated, temperature compensated on-chip power detector. The device includes on-chip ESD protection structures and DC by-pass capacitors to ease the implementation and volume assembly of the packaged part. The device is manufactured in GaAs PHEMT device technology with BCB wafer coating to enhance ruggedness and repeatability of performance. The XP1035-QH is specifically designed for PtP radio applications and is well suited for other telecom applications such as SATCOM and VSAT.

Ordering Information ¹

Part Number	Package
XP1035-QH-0G00	bulk quantity
XP1035-QH-0G0T	tape and reel
XP1035-QH-EV1	evaluation module

1. Reference Application Note M513 for reel size information.

Functional Schematic

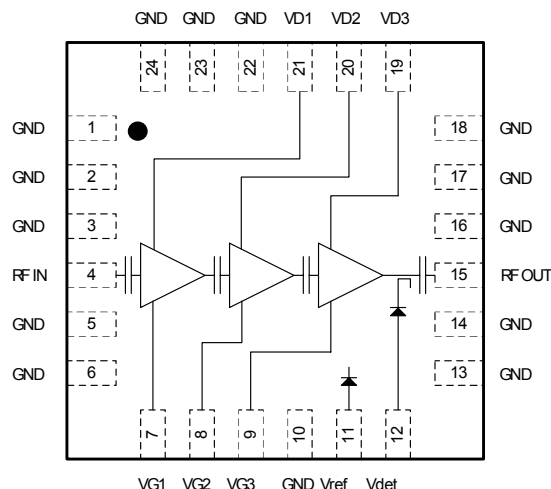

Pin Configuration ²

Pin No.	Function	Pin No.	Function
1-3	Ground	12	Pwr Det
4	RF Input	13-14	Ground
5-6	Ground	15	RF Output
7	Gate 1 Bias	16-18	Ground
8	Gate 2 Bias	19	Drain 3 Bias
9	Gate 3 Bias	20	Drain 2 Bias
10	Ground	21	Drain 1 Bias
11	Pwr Det Ref.	22-24	Ground

2. The exposed pad centered on the package bottom must be connected to RF and DC ground.

* Restrictions on Hazardous Substances, European Union Directive 2002/95/EC.

Electrical Specifications: 5.9 - 9.5 GHz (Ambient Temperature T = 25°C)

Parameter	Units	Min.	Typ.	Max.
Small Signal Gain (S21)	dB	-	26	-
Input Return Loss (S11)	dB	-	13	-
Output Return Loss (S22)	dB	-	10	-
Reverse Isolation (S12)	dB	-	45	-
Psat	dBm	-	29	-
P1dB	dBm	-	27.5	-
OIP3	dBm	-	39	-
Drain Bias Voltage (Vd1,2,3)	VDC	-	6	-
Detector Bias Voltage (Vdet,ref)	VDC	-	5	-
Gate Bias Voltage (Vg1,2,3)	VDC	-2	-1	-
Supply Current (Id1)	mA	-	70	-
Supply Current (Id2)	mA	-	140	-
Supply Current (Id3)	mA	-	280	-

Absolute Maximum Ratings ^{3,4}

Parameter	Absolute Max.
Supply Voltage (Vd1,2,3)	+7.2 V
Supply Current (Id1,2,3)	600 mA
Gate Bias Voltage (Vg1,2,3)	-3 V
Max Power Dissipation (P _{diss})	4.2 W
RF Input Power	+15 dBm
Operating Temperature (T _a)	-55°C to +85°C
Storage Temperature (T _{stg})	-65°C to +165°C
Channel Temperature (T _{ch}) ²	150°C
MSL Level (MSL)	MSL3

- Operation of this device above any one of these parameters may cause permanent damage.
- Channel temperature directly affects a device's MTTF. Channel temperature should be kept as low as possible to maximize lifetime.

Recommended Layout

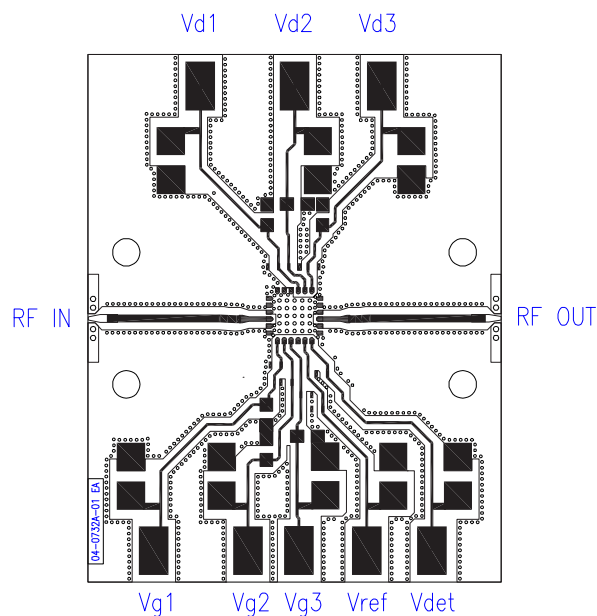

Recommended Decoupling Capacitors: 100pF 0402, 10µF 0805

Typical Performance Curves

XP1035-QH: S11 (dB) at Vd=6V, Id=500mA

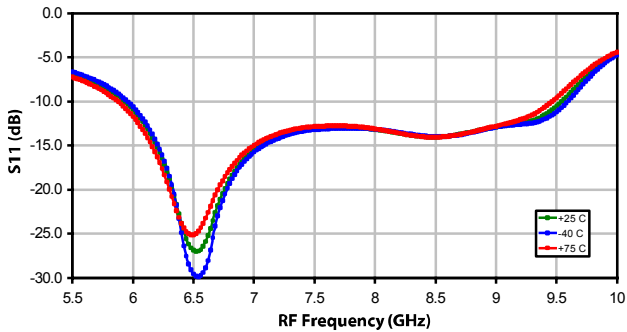

XP1035-QH: S21 (dB) at Vd=6V, Id=500mA

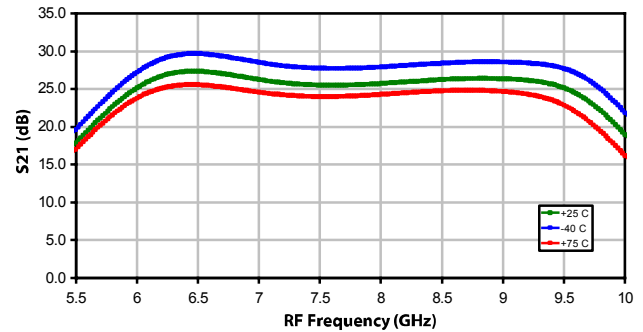

XP1035-QH: S22 (dB) at Vd=6V, Id=500mA

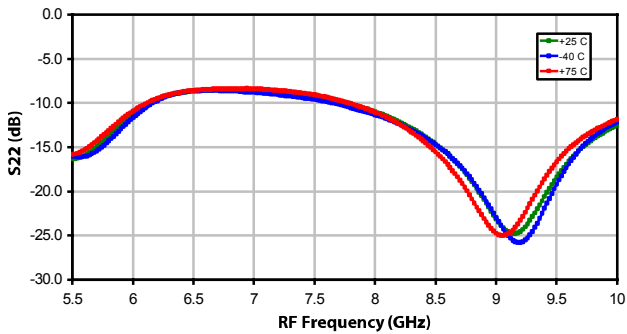

XP1035-QH: S12 (dB) at Vd=6V, Id=500mA

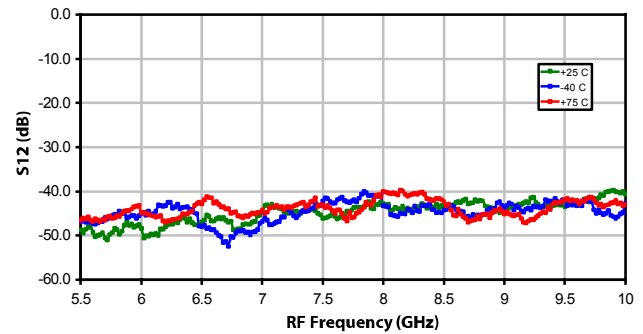

XP1035-QH: OIP3 (dBm) at Vd=6V, Id=500mA

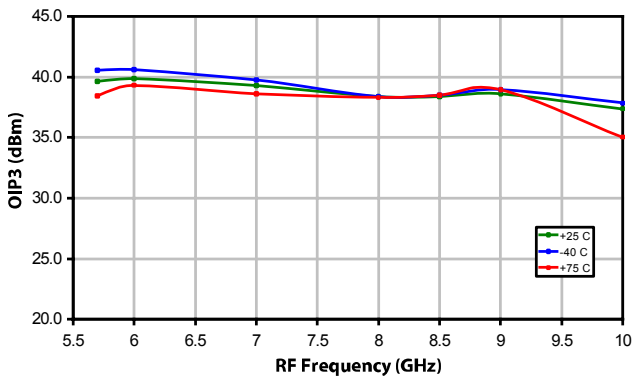

XP1035-QH: Psat (dBm) at Id=500mA, Vd=6V

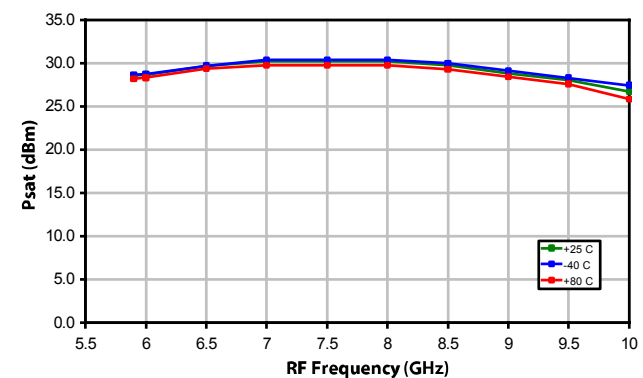

Typical Performance Curves (cont.)

XP1035-QH: Pout (dBm) and Gain (dB) vs Pin (dBm)
Id=500mA, Vd=6V, +25 C

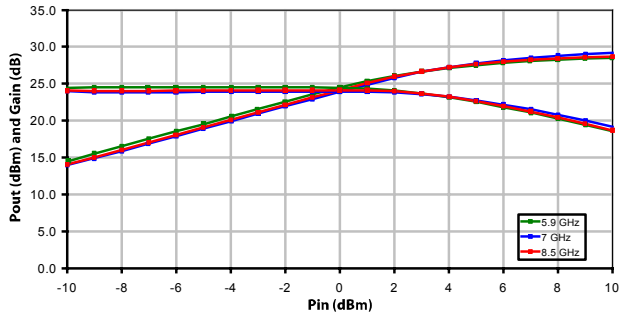

XP1035-QH: C/I3 vs Pout at Id=500mA, Vd=6V, +25 C, 10 MHz Span

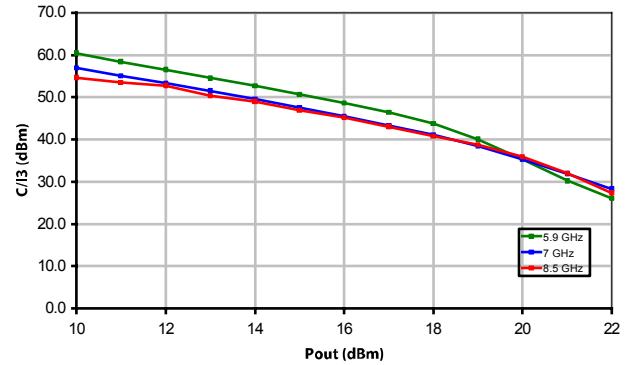

XP1035-QH: P1dB (dBm) at Id=500mA, Vd=6V

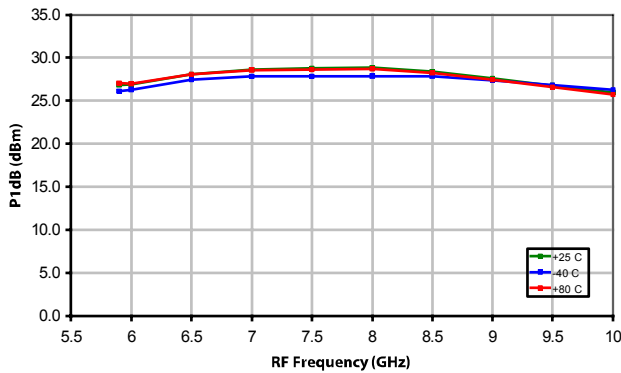

XP1035-QH: Detector (mV) vs Pout (dBm) at Id=500mA, Vd=6V, +25 C

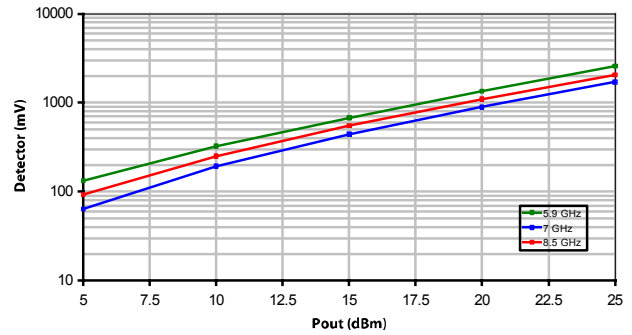

XP1035-QH: Detector (mV) vs Pout (dBm) at Id=500mA, Vd=6V, -40 C

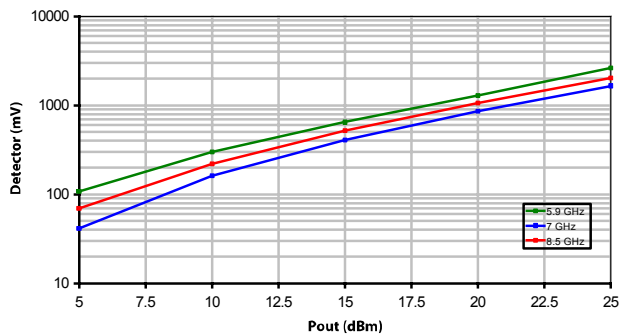

XP1035-QH: Detector (mV) vs Pout (dBm) at Id=500mA, Vd=6V, +80 C

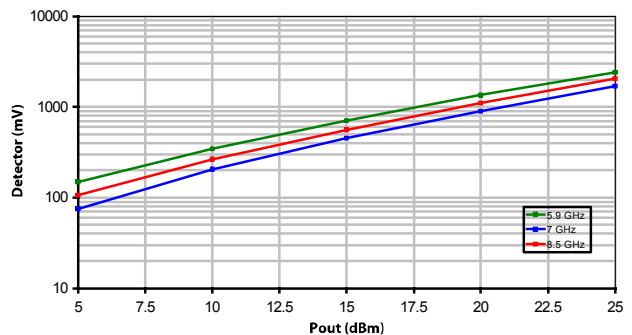

MTTF

XP1035-QH-0G00: MTTF (hours) vs. Package Base Temperature
Vdd = 6.0 V, Idd = 500 mA

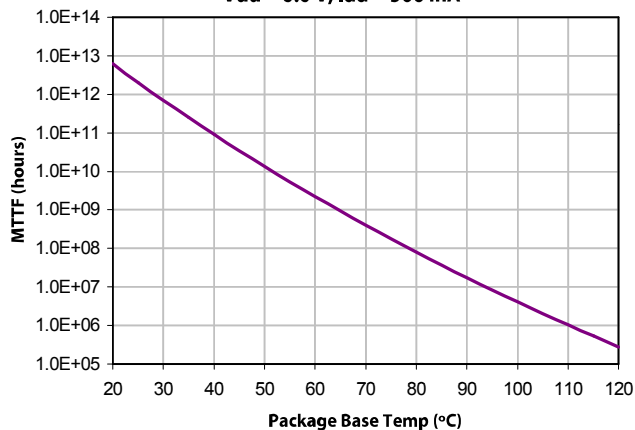

XP1035-QH-0G00: MTTF (hours) vs. Package Base Temperature
Vdd = 6.0 V, Idd = 500 mA

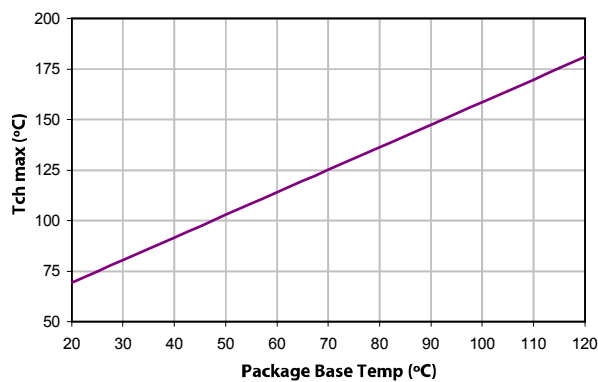

XP1035-QH-0G00: Rth vs. Package Base Temperature
Vdd = 6.0 V, Idd = 500 mA

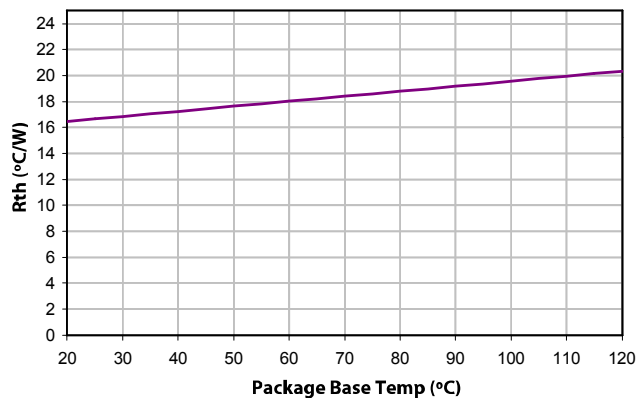

App Note [1] Biasing - As shown in the Pin Designations table, the device is operated by biasing VD1,2,3 at 5.0V with 70, 140, 280mA respectively. It is recommended to use active bias to keep the currents constant in order to maintain the best performance over temperature. Depending on the supply voltage available and the power dissipation constraints, the bias circuit may be a single transistor or a low power operational amplifier, with a low value resistor in series with the drain supply used to sense the current. The gate of the pHEMT is controlled to maintain correct drain current and thus drain voltage. The typical gate voltage needed to do this is -1.0V. Make sure to sequence the applied voltage to ensure negative gate bias is available before applying the positive drain supply.

App Note [2] Board Layout - As shown in the board layout, it is recommended to provide 100pF decoupling caps as close to the bias pins as possible, with additional 10 μ F decoupling caps.

Lead-Free 4 mm 24-Lead PQFN[†]

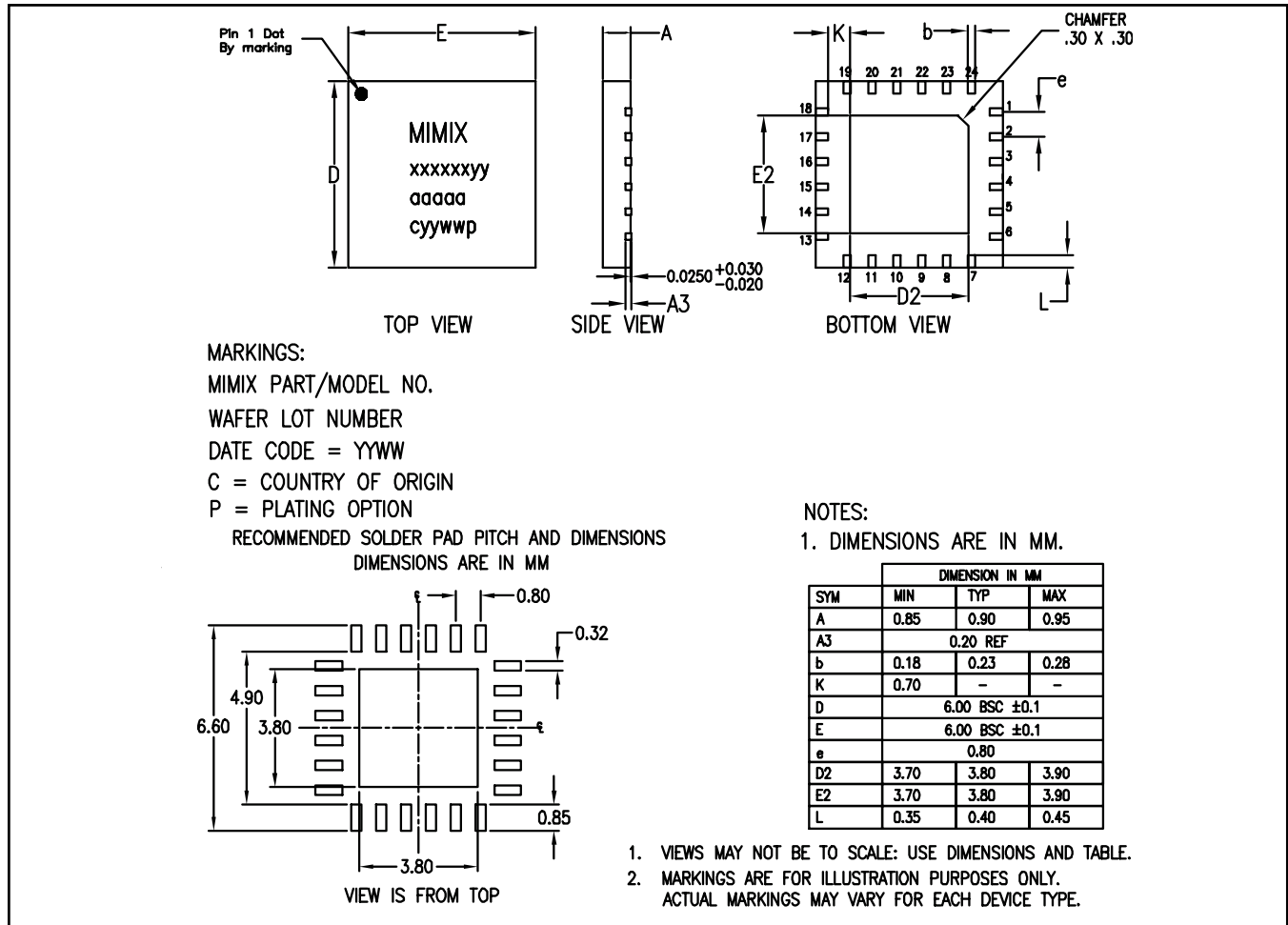

[†] Reference Application Note S2083 for lead-free solder reflow recommendations.
Plating is 100% matte tin over copper.

Handling Procedures

Please observe the following precautions to avoid damage:

Static Sensitivity

Gallium Arsenide Integrated Circuits are sensitive to electrostatic discharge (ESD) and can be damaged by static electricity. Proper ESD control techniques should be used when handling these devices.

M/A-COM Technology Solutions Inc. All rights reserved.

Information in this document is provided in connection with M/A-COM Technology Solutions Inc ("MACOM") products. These materials are provided by MACOM as a service to its customers and may be used for informational purposes only. Except as provided in MACOM's Terms and Conditions of Sale for such products or in any separate agreement related to this document, MACOM assumes no liability whatsoever. MACOM assumes no responsibility for errors or omissions in these materials. MACOM may make changes to specifications and product descriptions at any time, without notice. MACOM makes no commitment to update the information and shall have no responsibility whatsoever for conflicts or incompatibilities arising from future changes to its specifications and product descriptions. No license, express or implied, by estoppel or otherwise, to any intellectual property rights is granted by this document.

THESE MATERIALS ARE PROVIDED "AS IS" WITHOUT WARRANTY OF ANY KIND, EITHER EXPRESS OR IMPLIED, RELATING TO SALE AND/OR USE OF MACOM PRODUCTS INCLUDING LIABILITY OR WARRANTIES RELATING TO FITNESS FOR A PARTICULAR PURPOSE, CONSEQUENTIAL OR INCIDENTAL DAMAGES, MERCHANTABILITY, OR INFRINGEMENT OF ANY PATENT, COPYRIGHT OR OTHER INTELLECTUAL PROPERTY RIGHT. MACOM FURTHER DOES NOT WARRANT THE ACCURACY OR COMPLETENESS OF THE INFORMATION, TEXT, GRAPHICS OR OTHER ITEMS CONTAINED WITHIN THESE MATERIALS. MACOM SHALL NOT BE LIABLE FOR ANY SPECIAL, INDIRECT, INCIDENTAL, OR CONSEQUENTIAL DAMAGES, INCLUDING WITHOUT LIMITATION, LOST REVENUES OR LOST PROFITS, WHICH MAY RESULT FROM THE USE OF THESE MATERIALS.

MACOM products are not intended for use in medical, lifesaving or life sustaining applications. MACOM customers using or selling MACOM products for use in such applications do so at their own risk and agree to fully indemnify MACOM for any damages resulting from such improper use or sale.