

XPB-2910LWG / XPS-2910BLWG

(RoHS Compliant)

1330 nm TX / 1270 nm RX , 10.3 Gbps 1-Fiber Single-Mode LC XFP Transceiver

FEATURES

- 1-Fiber Bi-Directional XFP Optical Transceiver
- Up to 10.3 Gbps Bi-directional Data Links
- Compliant with XFP MSA
- Compliant to IEEE 802.3ae 10GBASE-BX
- SFF-8472 Digital Diagnostic Function
- Simplex LC Connector
- 1330 nm DFB LD Transmitter
- 1270 nm Receiver
- Distance Up to 10 km
- 2-Wire Interface for Integrated Digital Diagnostic Monitoring
- XFI Loopback Mode
- No reference Clock required
- Only Required +3.3 V Power Supply
- Power Consumption < 2 W
- RoHS Compliant
- 0 to 70°C Operating : XPB-2910LWG
- -10 to 85°C Operating : XPS-2910BLWG
- Simplex LC Connector

APPLICATIONS

- 10GBASE-BX at 10.3125 Gb/s
- 10GBASE-BX at 9.953 Gb/s

LASER SAFETY

This single-mode transceiver is a Class 1 laser product. It complies with IEC-60825 and FDA 21 CFR 1040.10 and 1040.11. The transceiver must be operated within the specified temperature and voltage limits. The optical ports of the module shall be terminated with an optical connector or with a dust plug.

DESCRIPTION

XPB-2910LWG series transceiver is designed for bi-directional serial optical data communications such as IEEE 802.3ae 10GBASE-BX by using 1330 nm transmitter and 1270 nm receiver.

The transceiver consists of two sections: The transmitter section uses a multiple quantum well 1330 nm DFB laser and is a class 1 laser compliant according to International Safety Standard IEC 60825. The receiver section uses an integrated 1270 nm detector preamplifier (IDP) mounted in an optical header and a limiting post-amplifier IC.

The module is with the XFP 30-pin connector to allow hot plug capability. Integrated Tx and Rx signal conditioners provide high jitter-tolerance for full XFI compliance and no external reference clock required. The internally ac coupled high speed serial I/O simplifies interfacing to external circuitry. Only single 3.3V power supply is needed. The optical output can be disabled by LVTTTL logic high-level input of TX_DIS. Loss of signal (RX_LOS) output is provided to indicate the loss of an input optical signal of receiver.

A serial EEPROM in the transceiver allows the user to access transceiver digital diagnostic monitoring and configuration data via the 2-wire XFP Management Interface. This interface uses a single address, A0h, with a memory map divided into a lower and upper area. Basic digital diagnostic data is held in the lower area while specific data is held in a series of tables in the high memory area.

ORDER INFORMATION

| P/No. | Bit Rate (Gb/s) | 10GBASE | Distance (km) | TX (nm) | RX (nm) | Package | Temp (°C) | RoHS Compliant |
|--------------|-----------------|---------|---------------|----------|---------|-----------------|-----------|----------------|
| XPB-2910LWG | 10.3 | BX | 10 | 1330 DFB | 1270 | LC XFP with DMI | 0 to 70 | Yes |
| XPS-2910BLWG | 10.3 | BX | 10 | 1330 DFB | 1270 | LC XFP with DMI | -10 to 85 | Yes |

| Absolute Maximum Ratings | | | | | |
|----------------------------|------------------|----------|----------|-------|-----------------------------|
| Parameter | Symbol | Min | Max | Units | Notes |
| Storage Temperature | Tstg | -40 | 85 | °C | |
| Operating Case Temperature | To _{pr} | 0 -10 | 70 85 | °C | XPB-2910LWG XPB-2910BLWG |
| Relative Humidity | RH | 0 | 85 | % | Non condensing |
| Power Supply Voltage | V _{CC3} | 0 | 3.6 | V | |

| Recommended Operating Conditions | | | | | |
|----------------------------------|------------------|----------|------|----------|---------------------------------------|
| Parameter | Symbol | Min | Typ | Max | Units / Notes |
| Power Supply Voltage | V _{CC3} | 3.13 | 3.3 | 3.47 | V |
| Power Supply Current (@3.3V) | I _{CC3} | | | 550 | mA |
| Power Dissipation | P _D | | | 2 | W |
| Operating Case Temperature | To _{pr} | 0 -10 | | 70 85 | °C / XPB-2910LWG °C / XPB-2910BLWG |
| Data Rate | | 9.95 | 10.3 | | Gb/s |

| Transmitter Optical Specifications (To _{pr} = 0 to 70°C, V _{cc3} = 3.3V ±5%) | | | | | | |
|--|---|------|------|------|-------|--------------|
| Parameter | Symbol | Min | Typ | Max | Units | Notes |
| Average Launch Power | P _{O, Avg} | -5 | | 0 | dBm | 1 |
| Output Center Wavelength | λ _c | 1320 | 1330 | 1340 | nm | |
| Output Spectrum Width | σ _λ | | | 1 | nm | -20 dB width |
| Side Mode Suppression Ratio | SMSR | 30 | | | dB | |
| Relative Intensity Noise | RIN | | | -128 | dB/Hz | |
| Optical Eye Mask | Compliant with IEEE 802.3ae 10GBASE-L XFP MSA | | | | | |
| Average Launch Power of OFF Transmitter | | | | -30 | dBm | |

1. Output power is power coupled into a 9/125 μm single-mode fiber.

| Receiver Optical Specifications (To _{pr} = 0 to 70°C, V _{cc3} = 3.3V ±5%) | | | | | | |
|---|------------------|------|-----|------|-------|---------------------------|
| Parameter | Symbol | Min | Typ | Max | Units | Notes |
| Sensitivity @10.3 Gb/s | Sen _l | | | -14 | dBm | 2, average received power |
| Receiver Overload | P _{MAX} | 0.5 | --- | | dBm | |
| LOS -- Deasserted | LOS _D | --- | --- | -18 | dBm | Transition: low to high |
| LOS -- Asserted | LOS _A | -30 | --- | --- | dBm | Transition: high to low |
| LOS -- Hysteresis | | 1 | --- | 5 | dB | |
| Wavelength of Operation | λ _c | 1260 | | 1280 | nm | 3 |

2. Measured with worst ER; BER < 10⁻¹² and PRBS 2³¹-1.

3. At least 30 dB optical isolation for the wavelength 1320 to 1340 nm.

| Electrical Characteristics | | | | | | |
|--|------------------|------|------|-----------------|------------------|--------------------------|
| Parameter | Symbol | Min | Typ | Max | Units | Notes |
| High-Speed Signal (CML) Interface Specification | | | | | | |
| Input Data Rate | | 9.95 | 10.3 | | Gb/s | |
| Differential Input Impedance | R _{in} | | 100 | | Ω | |
| Differential Data Input Amplitude | | 120 | | 820 | mV _{pp} | 4, Internally AC coupled |
| Output Data Rate | | 9.95 | 10.3 | | Gb/s | |
| Differential Output Impedance | R _{out} | | 100 | | Ω | |
| Differential Data Output Amplitude | | 340 | | 850 | mV _{pp} | 4, Internally AC coupled |
| Low-Speed Signal (LVTTTL) Interface Specification | | | | | | |
| Input High Voltage | | 2.0 | | V _{cc} | V | |
| Input Low Voltage | | GND | | 0.8 | V | |
| Output High Voltage | | 2.4 | | V _{cc} | V | |
| Output Low Voltage | | GND | | 0.5 | V | |
| Reference Clock (LVPECL) Interface Specification | | | | | | |
| No reference clock | | | | | | |

4. The differential input and output amplitudes are per XFP MSA mask at points B' and C'.

| Transceiver Timing Characteristics | | | | | | |
|------------------------------------|--------------------------------|-----|-----|-----|-------|-------|
| Parameter | Symbol | Min | Typ | Max | Units | Notes |
| TX_DIS Assert Time | t _{off} | | | 10 | μs | |
| TX_DIS Negate Time | t _{on} | | | 2 | ms | |
| Time to Initialize | t _{init} | | | 300 | ms | |
| Interrupt Assert Delay | interrupt _{on} | | | 200 | ms | |
| Interrupt Negate Delay | interrupt _{off} | | | 500 | μs | |
| P_Down/PST Assert Delay | P_Down/RST _{on} | | | 100 | μs | |
| P_Down Negate Delay | P_Down/RST _{off} | | | 300 | ms | |
| Mod_NR Assert Delay | Mod_nr _{on} | | | 1 | ms | |
| Mod_NR Negate Delay | Mod_nr _{off} | | | 1 | ms | |
| Mod_Desel Assert Time | T_Mod_Desel | | | 2 | ms | |
| Mod_Desel De-Assert Time | T_Mod_Sel | | | 2 | ms | |
| P_Down Reset Time | T _{reset} | 10 | | | μs | |
| RX_LOS Assert Delay | T _{Los_{on}} | | | 100 | μs | |
| RX_LOS Negate Delay | T _{Los_{off}} | | | 100 | μs | |
| Serial ID Clock Rate | f _{SCL} | 0 | | 400 | kHz | |

Management Interface

The structure of the memory map is shown in Figure 1, which is accessible over a 2-wire serial interface at the 8-bit address 1010000X (A0h). The normal 256 byte I2C address space is divided into low and upper blocks of 128 Bytes. The lower block of 128 Bytes is always directly available and is used for the diagnostics and control function. Multiple blocks of memories are available in the upper 128 Bytes of the address space. These are individually addressed through a table select Byte which the user enters into a location in the lower address space. Thus, there is a total available address space of 128*256 = 32 Kbytes in this upper memory space. The contents of Table 01h are listed in Table 1 below. Please refer SFF INF-8077i (Revision 4.5) for detailed information.

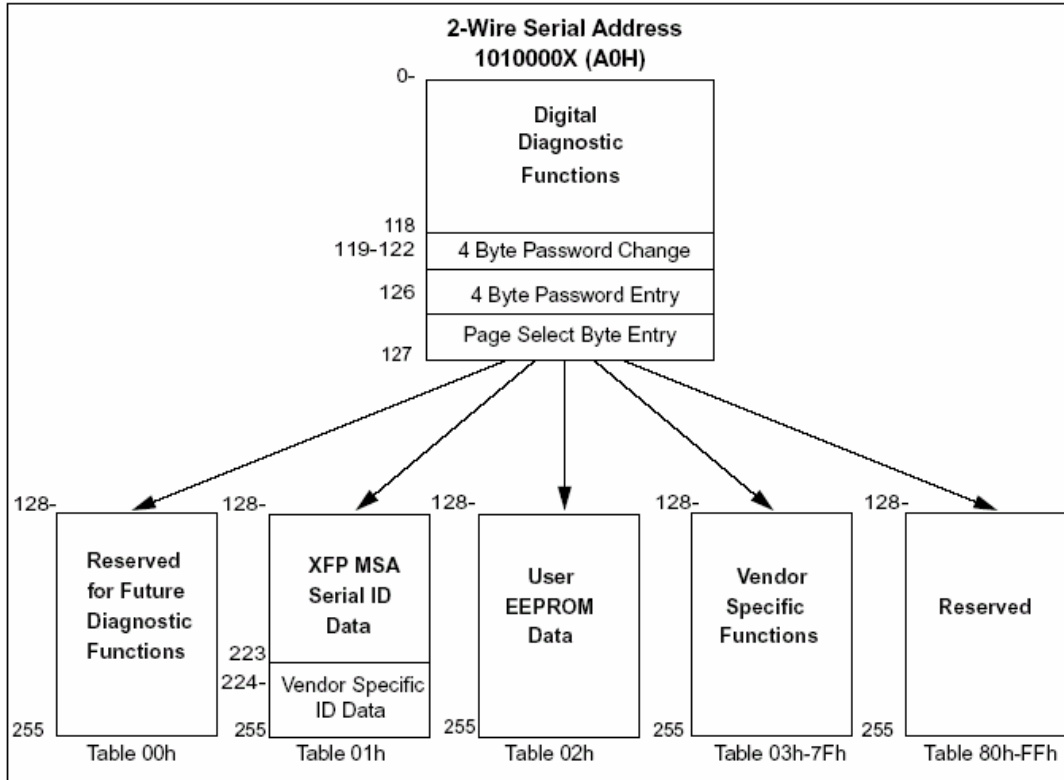

Figure 1. 2-wire Serial Digital Diagnostic Memory Map

Table 1 Monitoring Specification

| Data Address | Parameter | Accuracy |
|--------------|-------------|----------|
| 96 ~ 97 | Temperature | ± 3°C |
| 98 ~ 99 | Reserved | |
| 100 ~ 101 | Tx Bias | ± 10% |
| 102 ~ 103 | Tx Power | ± 2dB |
| 104 ~ 105 | Rx Power | ± 2dB |
| 106 ~ 107 | Vcc3 | ± 3% |

CONNECTION DIAGRAM

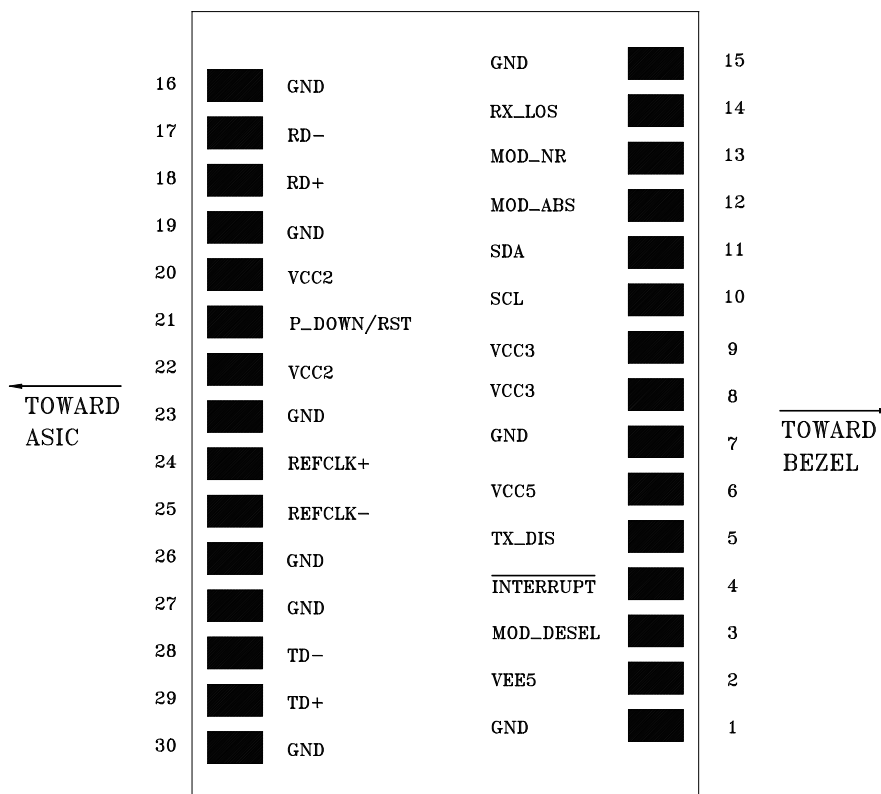

Table 3 PIN Description

| PIN | Logic | Signal Name | Description | Note |
|-----|-----------|-------------|--|------|
| 1 | | GND | Module Ground | 1 |
| 2 | | VEE5 | -5.2V Power Supply (Not required) | 3 |
| 3 | LVTTL-I | Mod_Desel | Module De-select; When held low allows module to respond to 2-wire serial interface | |
| 4 | LVTTL-O | Interrupt | Interrupt; Indicates presence of an important condition which can be read over the 2-wire serial interface | 2 |
| 5 | LVTTL-I | TX_DIS | Transmitter Disable; Turns off transmitter laser output | |
| 6 | | VCC5 | +5V Power Supply (Not required) | 3 |
| 7 | | GND | Module Ground | 1 |
| 8 | | VCC3 | +3.3V Power Supply | |
| 9 | | VCC3 | +3.3V Power Supply | |
| 10 | LVTTL-I/O | SCL | Serial 2-wire interface clock | 2 |
| 11 | LVTTL-I/O | SDA | Serial 2-wire interface data line | 2 |
| 12 | LVTTL-O | Mod_Abs | Indicates Module is not present. Grounded in the Module | 2 |
| 13 | LVTTL-O | Mod_NR | Module Not Ready; Indicating Module Operational Fault | 2 |
| 14 | LVTTL-O | RX_LOS | Receiver Loss Of Signal Indicator | 2 |
| 15 | | GND | Module Ground | 1 |
| 16 | | GND | Module Ground | 1 |
| 17 | CML-O | RD- | Receiver Inverted Data Output | |
| 18 | CML-O | RD+ | Receiver Non-Inverted Data Output | |
| 19 | | GND | Module Ground | 1 |
| 20 | | VCC2 | +1.8V Power Supply (Not required) | 3 |

OPTOWAY TECHNOLOGY INC. No.38, Kuang Fu S. Road, Hu Kou, Hsin Chu Industrial Park, Hsin Chu, Taiwan 303
 Tel: 886-3-5979798 Fax: 886-3-5979737

E-mail: sales@optoway.com.tw http://www.optoway.com.tw 2008/11/1 V1.0

| | | | | |
|----|----------|------------|---|---|
| 21 | LVTTTL-I | P_Down/RST | Power down; When high, requires the module to limit power consumption to 1.5W or below. 2-Wire serial interface must be functional in the low power mode. Reset; The falling edge initiates a complete reset of the module including the 2-wire serial interface, equivalent to a power cycle. | |
| 22 | | VCC2 | +1.8V Power Supply (Not required) | 3 |
| 23 | | GND | Module Ground | 1 |
| 24 | PECL-I | RefCLK+ | Reference Clock Non-Inverted Input, AC coupled on the host board. (Not used. Internally terminated to 50 ohm (100 ohm diff.)) | 4 |
| 25 | PECL-I | RefCLK- | Reference Clock Inverted Input, AC coupled on the host board. (Not used. Internally terminated to 50 ohm (100 ohm diff.)) | 4 |
| 26 | | GND | Module Ground | 1 |
| 27 | | GND | Module Ground | 1 |
| 28 | CML-I | TD- | Transmitter Inverted Data Input | |
| 29 | CML-I | TD+ | Transmitter Non-Inverted Data Input | |
| 30 | | GND | Module Ground | 1 |

1. Module ground pins GND are isolated from the module case and chassis ground within the module.
2. Shall be pulled up with 4.7K-10Kohms to a voltage between 3.15V and 3.45V on the host board.
3. These PINs are open within module.
4. A Reference Clock input is not required. If present, it will be ignored.

Mechanical Specification (Units in mm)

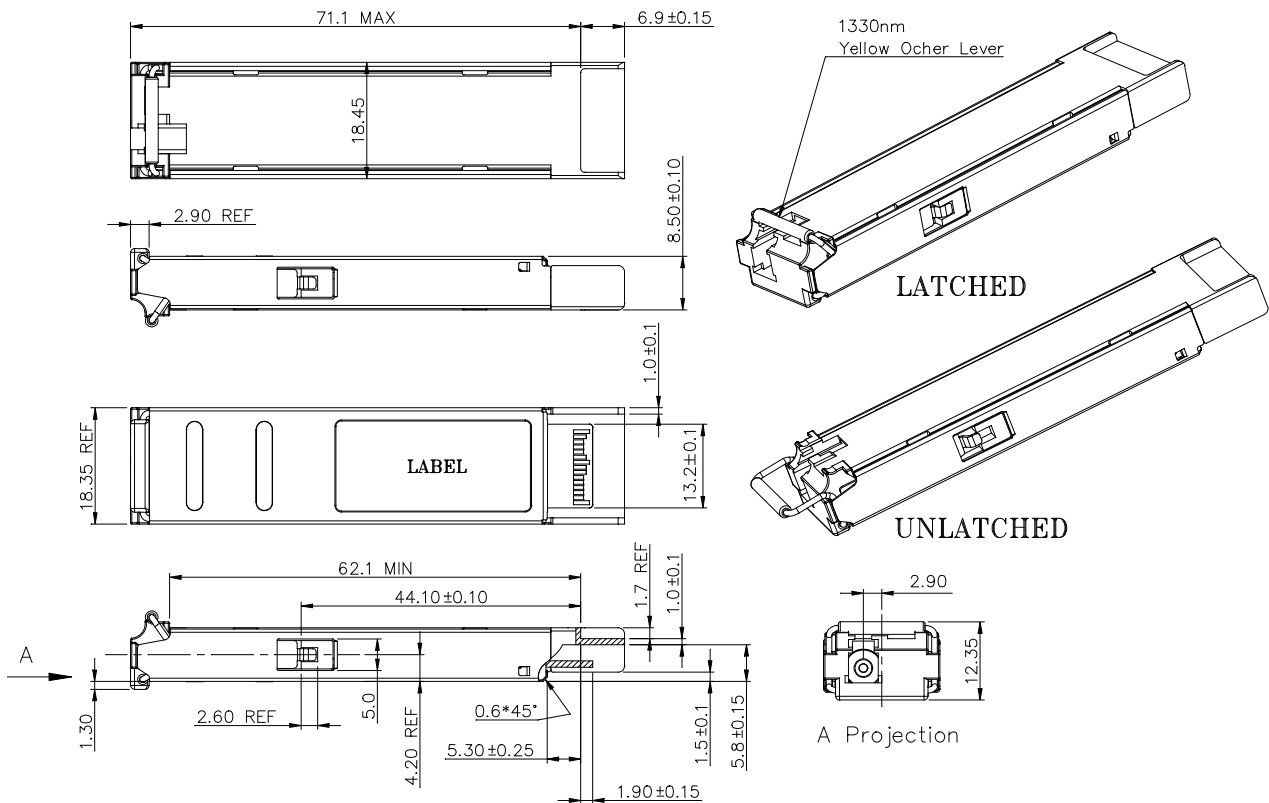

Recommended Power Circuit Schematic

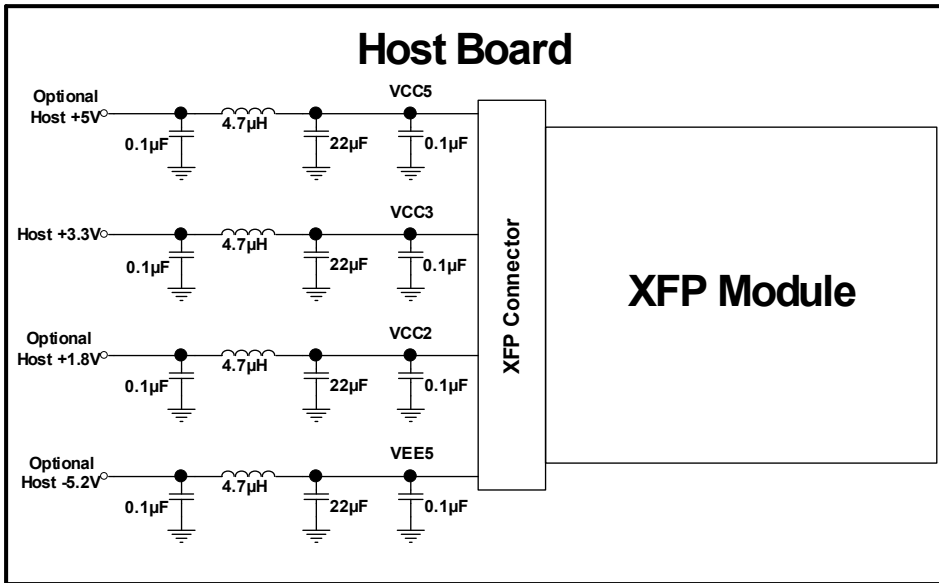

Recommended Interface Circuit

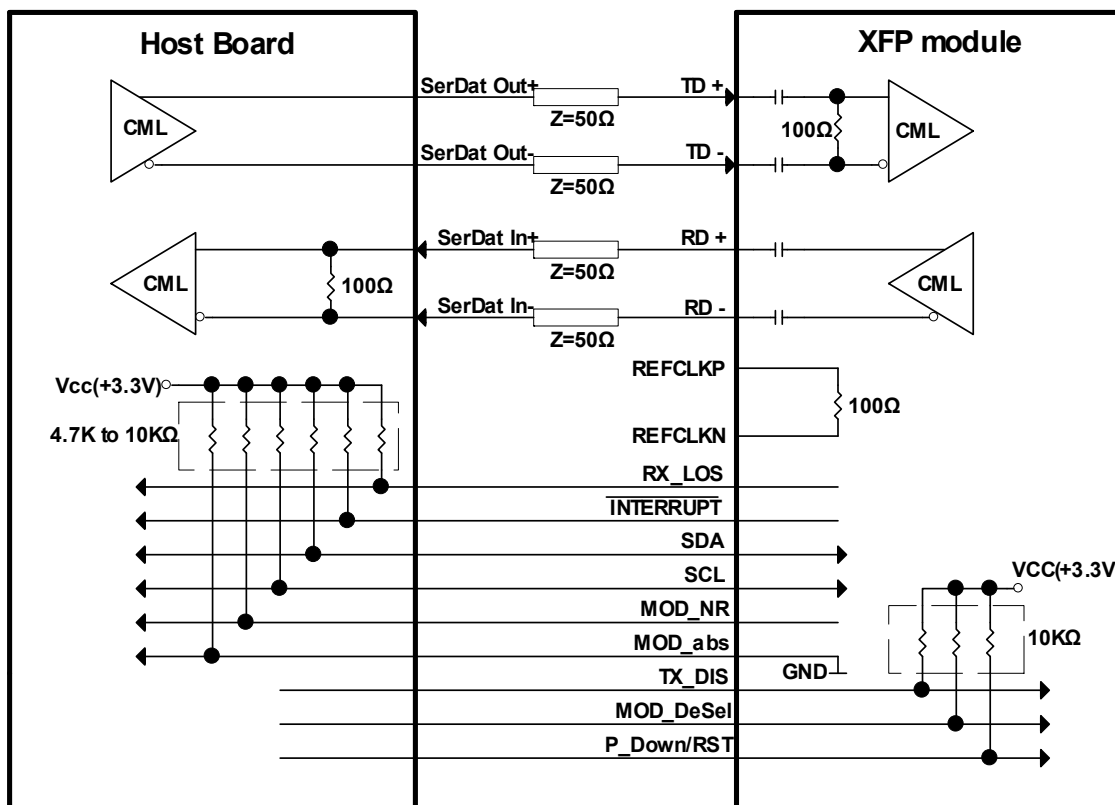

Table 2 Serial ID Memory Contents (Table 01h)

| Address | Field Size (Byte) | Name of Filed | Description | Hex |
|---------|-------------------|----------------------------|--|--|
| 128 | 1 | Identifier | XFP | 06 |
| 129 | 1 | Ext. Identifier | power consumption < 2 W, no Ref Clock required | 50 |
| 130 | 1 | Connector type | LC connector | 07 |
| 131~138 | 8 | Transceiver | 10GBASE-BX, 10GBASE-LR/LW, 10GFC 1200-SM-LL-L | 44 40 00 00 00 00 00 00 |
| 139 | 1 | Encoding | 64B/66B, 8B10B, NRZ | D0 |
| 140 | 1 | BR-Min | 9.9Gbps | 63 |
| 141 | 1 | BR-Max | 10.3Gbps | 67 |
| 142 | 1 | length (SMF)-Km | 10 Km | 0A |
| 143 | 1 | Length (E-50µm) | 0 m | 00 |
| 144 | 1 | Length (50 µm) | 0 m | 00 |
| 145 | 1 | Length (62.5 µm) | 0 m | 00 |
| 146 | 1 | Length (Copper) | 0 m | 00 |
| 147 | 1 | Device Tech | Uncooled 1330DFB, PIN detector | 40 |
| 148~163 | 16 | Vendor name | OPTOWAY | 4F 50 54 4F 57 41 59 20 20 20 20 20 20 20 20 20 |
| 164 | 1 | CDR Support | CDR supports 9.953G ~ 10.3G, XFI Loopback | C1 |
| 165~167 | 3 | Vendor OUI | | 00 0E FA |
| 168~183 | 16 | Vendor PN | XPB-2910LWG | 58 50 42 2D 32 39 31 30 4C 57 47 20 20 20 20 20 |
| | | | XPB-2910BLWG | 58 50 42 2D 32 39 31 30 42 4C 57 47 20 20 20 20 |
| 184~185 | 2 | Vendor rev | ASCII ("31 61" means 1a revision) | xx xx |
| 186~187 | 2 | Wavelength | 1330 nm | 67 E8 |
| 188~189 | 2 | Wavelength Tolerance | +/- 10 nm | 07D0 |
| 190 | 1 | Max Case Temp | 70deg (for XPB-2910LWG) | 46 |
| | | | 85deg (for XPB-2910BLWG) | 55 |
| 191 | 1 | CC_BASE | Check sum of Byte 128 -- 190 | |
| 192~195 | 4 | Power Supply | 2Wmax, 1.5W pd max , 550mA 3.3V | 64 96 06 00 |
| 196~211 | 16 | Vendor SN | ASCII | xx xx xx xx xx xx xx xx xx xx xx xx xx xx xx xx |
| 212~219 | 8 | Date code | ASCII Year (2 Byte), Month (2 Byte), Day (2 Byte) | xx xx xx xx xx xx 20 20 |
| 220 | 1 | Diagnostic Monitoring Type | No BER Support, Average Power | 08 |
| 221 | 1 | Enhanced Options | Optional Soft TX_DISABLE implemented, Optional Soft P_down implemented | 60 |
| 222 | 1 | Aux Monitoring | AUX1 for Vcc3. | 70 |
| 223 | 1 | CC_EXT | Check sum of Byte 192 -- 222 | |
| 224~255 | 32 | Vendor Specific | | Reserved |

Note: Specifications subject to change without notice.

Revision History

| Version | Subject | Release Date |
|---------|-------------------|--------------|
| 1.0 | Initial datasheet | 2008/11/1 |
| | | |
| | | |
| | | |