

Summary of QPro™ Virtex™-II Features

- Industry First Military Grade Platform FPGA Solution
- Certified to MIL-PRF-38535 (Qualified Manufacturer Listing)
- 100% Factory Tested
- Guaranteed over the full military temperature range (–55°C to +125°C)
- Ceramic and Plastic Wire-Bond and Flip-Chip Grid Array Packages
- IP-Immersion Architecture
 - Densities from 1M to 6M system gates
 - 300+ MHz internal clock speed (Advance Data)
 - 622+ Mb/s I/O (Advance Data)
- SelectRAM™ Memory Hierarchy
 - 2.5 Mb of dual-port RAM in 18 Kbit block SelectRAM resources
 - Up to 1 Mb of distributed SelectRAM resources
- High-Performance Interfaces to External Memory
 - DRAM interfaces
 - SDR/DDR SDRAM
 - Network FCRAM
 - Reduced Latency DRAM
 - SRAM interfaces
 - SDR/DDR SRAM
 - QDR SRAM
 - CAM interfaces
- Arithmetic Functions
 - Dedicated 18-bit x 18-bit multiplier blocks
 - Fast look-ahead carry logic chains
- Flexible Logic Resources
 - Up to 67,584 internal registers/latches with Clock Enable
 - Up to 67,584 look-up tables (LUTs) or cascadable 16-bit shift registers
 - Wide multiplexers and wide-input function support
 - Horizontal cascade chain and sum-of-products support
 - Internal 3-state busing
- High-Performance Clock Management Circuitry
 - Up to 12 DCM (Digital Clock Manager) modules
 - Precise clock de-skew
 - Flexible frequency synthesis
 - High-resolution phase shifting
 - 16 global clock multiplexer buffers
- Active Interconnect Technology
 - Fourth generation segmented routing structure
 - Predictable, fast routing delay, independent of fanout
- SelectIO™-Ultra Technology
 - Up to 824 user I/Os
 - 19 single-ended and six differential standards
 - Programmable sink current (2 mA to 24 mA) per I/O
 - Digitally Controlled Impedance (DCI) I/O: on-chip termination resistors for single-ended I/O standards
 - PCI compliant (32/33 MHz) at 3.3V
 - Differential Signaling
 - 622 Mb/s Low-Voltage Differential Signaling I/O (LVDS) with current mode drivers
 - Bus LVDS I/O
 - Lightning Data Transport (LDT) I/O with current driver buffers
 - Low-Voltage Positive Emitter-Coupled Logic (LVPECL) I/O
 - Built-in DDR input and output registers
 - Proprietary high-performance SelectLink Technology
 - High-bandwidth data path
 - Double Data Rate (DDR) link
 - Web-based HDL generation methodology
- Supported by Xilinx Foundation Series™ and Alliance Series™ Development Systems
 - Integrated VHDL and Verilog design flows
 - Compilation of 10M system gates designs
 - Internet Team Design (ITD) tool
- SRAM-Based In-System Configuration
 - Fast SelectMAP configuration
 - Triple Data Encryption Standard (DES) security option (Bitstream Encryption)
 - IEEE 1532 support
 - Partial reconfiguration
 - Unlimited reprogrammability
 - Readback capability
- 0.15 μm 8-Layer Metal Process with 0.12 μm High-Speed Transistors
- 1.5V (V_{CCINT}) Core Power Supply, Dedicated 3.3V V_{CCAUX} Auxiliary and V_{CCO} I/O Power Supplies
- IEEE 1149.1 Compatible Boundary-Scan Logic Support

Table 1: Virtex-II Field-Programmable Gate Array Family Members

Device	System Gates	CLB (1 CLB = 4 slices = Max 128 bits)			Multiplier Blocks	SelectRAM Blocks		DCMs	Max I/O Pads ⁽¹⁾
		Array Row x Col.	Slices	Maximum Distributed RAM Kbits		18 Kbit Blocks	Max RAM (Kbits)		
XQ2V1000	1M	40 x 32	5,120	160	40	40	720	8	432
XQ2V3000	3M	64 x 56	14,336	448	96	96	1,728	12	720
XQ2V6000	6M	96 x 88	33,792	1,056	144	144	2,592	12	1,104

Notes:

- See details in Table 2, "Maximum Number of User I/O Pads".

General Description

The Virtex-II family includes platform FPGAs developed for high performance from low-density to high-density designs that are based on IP cores and customized modules. The family delivers complete solutions for telecommunication, wireless, networking, video, and DSP applications, including PCI, LVDS, and DDR interfaces.

The leading-edge 0.15 μm /0.12 μm CMOS 8-layer metal process and the Virtex-II architecture are optimized for high speed with low power consumption. Combining a wide variety of flexible features and a large range of densities up to 8 million system gates, the Virtex-II family enhances programmable logic design capabilities and is a powerful alternative to mask-programmed gates arrays. As shown in Table 1, the QPro Virtex-II family comprises three members, ranging from 1M to 6M system gates.

Packaging

Offerings include ball grid array (BGA) packages with 1.00 mm and 1.27 mm pitches. In addition to traditional

Architecture

Virtex-II Array Overview

Virtex-II devices are user-programmable gate arrays with various configurable elements. The Virtex-II architecture is optimized for high-density and high-performance logic designs. As shown in Figure 1, the programmable device is comprised of input/output blocks (IOBs) and internal configurable logic blocks (CLBs).

wire-bond interconnects, flip-chip interconnect is used in some of the CGA offerings. The use of flip-chip interconnect offers more I/Os than is possible in wire-bond versions of the similar packages. Flip-chip construction offers the combination of high pin count with high thermal capacity.

Table 2 shows the maximum number of user I/Os available. The Virtex-II device/package combination table (Table 5 on page 5) details the maximum number of I/Os for each device and package using wire-bond or flip-chip technology.

Table 2: Maximum Number of User I/O Pads

Device	Wire-Bond	Flip-Chip
XQ2V1000	328	-
XQ2V3000	516	-
XQ2V6000	-	824

Programmable I/O blocks provide the interface between package pins and the internal configurable logic. Most popular and leading-edge I/O standards are supported by the programmable IOBs.

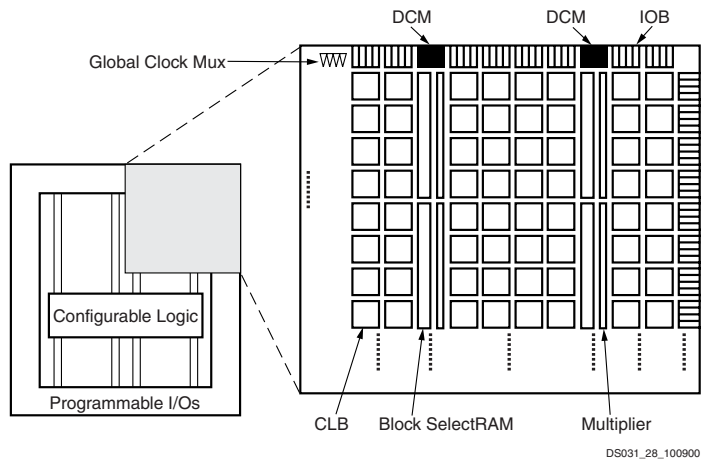

Figure 1: Virtex-II Architecture Overview

The internal configurable logic includes four major elements organized in a regular array:

- Configurable Logic Blocks (CLBs) provide functional elements for combinatorial and synchronous logic, including basic storage elements. BUFTs (3-state buffers) associated with each CLB element drive dedicated segmentable horizontal routing resources.
- Block SelectRAM memory modules provide large 18 Kbit storage elements of dual-port RAM.
- Multiplier blocks are 18-bit x 18-bit dedicated multipliers.
- DCM (Digital Clock Manager) blocks provide self-calibrating, fully digital solutions for clock distribution delay compensation, clock multiplication and division, coarse- and fine-grained clock phase shifting.

A new generation of programmable routing resources called Active Interconnect Technology interconnects all of these elements. The general routing matrix (GRM) is an array of routing switches. Each programmable element is tied to a switch matrix, allowing multiple connections to the general routing matrix. The overall programmable interconnection is hierarchical and designed to support high-speed designs.

All programmable elements, including the routing resources, are controlled by values stored in static memory cells. These values are loaded in the memory cells during configuration and can be reloaded to change the functions of the programmable elements.

Virtex-II Features

This section briefly describes Virtex-II features.

Input/Output Blocks (IOBs)

IOBs are programmable and can be categorized as follows:

- Input block with an optional single-data-rate or double-data-rate (DDR) register
- Output block with an optional single-data-rate or DDR register, and an optional 3-state buffer, to be driven directly or through a single or DDR register
- Bidirectional block (any combination of input and output configurations)

These registers are either edge-triggered D-type flip-flops or level-sensitive latches.

IOBs support the following single-ended I/O standards:

- LVTTTL, LVCMOS (3.3V, 2.5V, 1.8V, and 1.5V)
- PCI compatible (33 MHz) at 3.3V
- CardBus compliant (33 MHz) at 3.3V
- GTL and GTLP
- HSTL (Class I, II, III, and IV)
- SSTL (3.3V and 2.5V, Class I and II)
- AGP-2X

The digitally controlled impedance (DCI) I/O feature automatically provides on-chip termination for each I/O element.

The IOB elements also support the following differential signaling I/O standards:

- LVDS
- BLVDS (Bus LVDS)
- ULVDS
- LDT
- LVPECL

Two adjacent pads are used for each differential pair. Two or four IOB blocks connect to one switch matrix to access the routing resources.

Configurable Logic Blocks (CLBs)

CLB resources include four slices and two 3-state buffers. Each slice is equivalent and contains:

- Two function generators (F and G)
- Two storage elements
- Arithmetic logic gates
- Large multiplexers
- Wide function capability
- Fast carry look-ahead chain
- Horizontal cascade chain (OR gate)

The function generators F and G are configurable as 4-input look-up tables (LUTs), as 16-bit shift registers, or as 16-bit distributed SelectRAM memory.

In addition, the two storage elements are either edge-triggered D-type flip-flops or level-sensitive latches.

Each CLB has internal fast interconnect and connects to a switch matrix to access general routing resources.

Block SelectRAM Memory

The block SelectRAM memory resources are 18 Kb of dual-port RAM, programmable from 16K x 1 bit to 512 x 36 bits, in various depth and width configurations. Each port is totally synchronous and independent, offering three "read-during-write" modes. Block SelectRAM memory is cascadable to implement large embedded storage blocks. Supported memory configurations for dual-port and single-port modes are shown in [Table 3](#).

Table 3: Dual-Port And Single-Port Configurations

16K x 1 bit	2K x 9 bits
8K x 2 bits	1K x 18 bits
4K x 4 bits	512 x 36 bits

A multiplier block is associated with each SelectRAM memory block. The multiplier block is a dedicated 18 x 18-bit multiplier and is optimized for operations based on the block SelectRAM content on one port. The 18 x 18 multiplier can be used independently of the block SelectRAM resource. Read/multiply/accumulate operations and DSP filter structures are extremely efficient.

Both the SelectRAM memory and the multiplier resource are connected to four switch matrices to access the general routing resources.

Global Clocking

The DCM and global clock multiplexer buffers provide a complete solution for designing high-speed clocking schemes.

Up to 12 DCM blocks are available. To generate de-skewed internal or external clocks, each DCM can be used to eliminate clock distribution delay. The DCM also provides 90-, 180-, and 270-degree phase-shifted versions of its output clocks. Fine-grained phase shifting offers high-resolution phase adjustments in increments of 1/256 of the clock period. Very flexible frequency synthesis provides a clock output frequency equal to any M/D ratio of the input clock frequency, where M and D are two integers. For the exact timing parameters, see [QPro Virtex-II Switching Characteristics, page 51](#).

Virtex-II devices have 16 global clock MUX buffers with up to eight clock nets per quadrant. Each global clock MUX buffer can select one of the two clock inputs and switch glitch-free from one clock to the other. Each DCM block is able to drive up to four of the 16 global clock MUX buffers.

Routing Resources

The IOB, CLB, block SelectRAM, multiplier, and DCM elements all use the same interconnect scheme and the same access to the global routing matrix. Timing models are shared, greatly improving the predictability of the performance of high-speed designs.

There are a total of 16 global clock lines with eight available per quadrant. In addition, 24 vertical and horizontal long lines per row or column as well as massive secondary and local routing resources provide fast interconnect. Virtex-II buffered interconnects are relatively unaffected by net fanout, and the interconnect layout is designed to minimize crosstalk.

Horizontal and vertical routing resources for each row or column include:

- 24 long lines
- 120 hex lines
- 40 double lines
- 16 direct connect lines (total in all four directions)

Boundary Scan

Boundary-scan instructions and associated data registers support a standard methodology for accessing and configuring Virtex-II devices that complies with IEEE standards 1149.1 — 1993 and 1532. A system mode and a test mode are implemented. In system mode, a Virtex-II device performs its intended mission even while executing non-test boundary-scan instructions. In test mode, boundary-scan test instructions control the I/O pins for testing purposes. The Virtex-II Test Access Port (TAP) supports BYPASS, PRELOAD, SAMPLE, IDCODE, and USERCODE non-test instructions. The EXTEST, INTEST, and HIGHZ test instructions are also supported.

Virtex-II Device/Package Combinations and Maximum I/O

Wire-bond and flip-chip packages are available. **Table 4** shows the maximum possible number of user I/Os in wire-bond and flip-chip packages. **Table 5** shows the number of available user I/Os for all device/package combinations.

- FG denotes wire-bond fine-pitch Plastic BGA (1.00 mm pitch).
- BG denotes wire-bond standard Plastic BGA (1.27 mm pitch).

- CG denotes wire-bond fine-pitch Hermetic Ceramic Column Grid Array (1.27 mm pitch).
- CF denotes flip-chip fine-pitch non-Hermetic Ceramic Column Grid Array (1.00 mm pitch).

The number of I/Os per package include all user I/Os except the 15 control pins (CCLK, DONE, M0, M1, M2, PROG_B, PWRDWN_B, TCK, TDI, TDO, TMS, HSWAP_EN, DXN, DXP, and RSVD) and VBATT.

Table 4: Package Information

Package	FG456	BG575	BG728 & CG717	CF1144
Pitch (mm)	1.00	1.27	1.27	1.00
Size (mm)	23 x 23	31 x 31	35 x 35	35 x 35

Table 5: Virtex-II Device/Package Combinations and Maximum Number of Available I/Os

Package	Available I/Os		
	XQ2V1000	XQ2V3000	XQ2V6000
FG456	324	-	-
BG575	328	-	-
BG728	-	516	-
CG717	-	516	-
CF1144	-	-	824

Notes:

1. The BG728 and CG717 packages are pinout (footprint) compatible.
2. The CF1144 is pinout (footprint) compatible with the FF1152.

Virtex-II Ordering Information

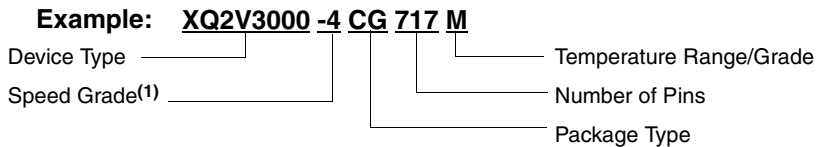

Device Ordering Options

Device Type	Package	
XQ2V1000	FG456	456-ball Plastic Fine Pitch BGA Package
XQ2V3000	BG575	575-ball Plastic BGA Package
XQ2V6000	BG728	728-ball Plastic BGA Package
	CG717	717-column Ceramic CGA Package
	CF1144	1144-column Ceramic Flip-Chip Package

Grade		Temperature
M	Military Ceramic	$T_C = -55^\circ\text{C}$ to $+125^\circ\text{C}$
N	Military Plastic	$T_J = -55^\circ\text{C}$ to $+125^\circ\text{C}$

Notes:

- 4 only supported speed grade.

Valid Ordering Combinations

M Grade	N Grade
XQ2V3000-4CG717M	XQ2V1000-4FG456N
XQ2V6000-4CF1144M ⁽¹⁾	XQ2V1000-4BG575N
	XQ2V3000-4BG728N

Notes:

- CF1144 is non-Hermetic Ceramic.

Detailed Description

Input/Output Blocks (IOBs)

Virtex-II I/O blocks (IOBs) are provided in groups of two or four on the perimeter of each device. Each IOB can be used as an input and/or an output for single-ended I/Os. Two IOBs can be used as a differential pair. A differential pair is always connected to the same switch matrix, as shown in [Figure 2](#).

IOB blocks are designed for high-performance I/Os, supporting 19 single-ended standards, as well as differential signaling with LVDS, LDT, Bus LVDS, and LVPECL.

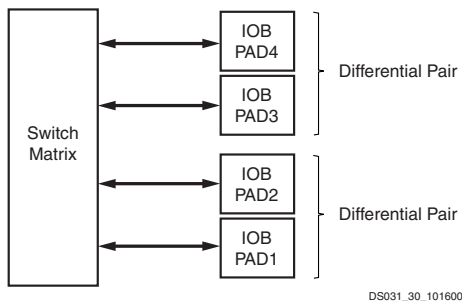

Figure 2: Virtex-II Input/Output Tile

Note: Differential I/Os must use the same clock.

Supported I/O Standards

Virtex-II IOB blocks feature SelectI/O-Ultra inputs and outputs that support a wide variety of I/O signaling standards. In addition to the internal supply voltage ($V_{CCINT} = 1.5V$), output driver supply voltage (V_{CCO}) is dependent on the I/O standard (see [Table 6](#)). An auxiliary supply voltage ($V_{CCAUX} = 3.3V$) is required, regardless of the I/O standard used. For exact supply voltage absolute maximum ratings, see [DC Input and Output Levels](#).

Table 6: Supported Single-Ended I/O Standards

I/O Standard	Output V_{CCO}	Input V_{CCO}	Input V_{REF}	Board Termination Voltage (V_{TT})
LVTTTL	3.3	3.3	N/A	N/A
LVCOS33	3.3	3.3	N/A	N/A
LVCOS25	2.5	2.5	N/A	N/A
LVCOS18	1.8	1.8	N/A	N/A
LVCOS15	1.5	1.5	N/A	N/A
PCI33_3	3.3	3.3	N/A	N/A
PCI66_3	3.3	3.3	N/A	N/A
PCI-X	3.3	3.3	N/A	N/A
GTL	Note 1	Note 1	0.8	1.2
GTL P	Note 1	Note 1	1.0	1.5
HSTL_I	1.5	N/A	0.75	0.75
HSTL_II	1.5	N/A	0.75	0.75
HSTL_III	1.5	N/A	0.9	1.5
HSTL_IV	1.5	N/A	0.9	1.5
HSTL_I	1.8	N/A	0.9	0.9
HSTL_II	1.8	N/A	0.9	0.9
HSTL_III	1.8	N/A	1.1	1.8
HSTL_IV	1.8	N/A	1.1	1.8
SSTL2_I	2.5	N/A	1.25	1.25
SSTL2_II	2.5	N/A	1.25	1.25
SSTL3_I	3.3	N/A	1.5	1.5
SSTL3_II	3.3	N/A	1.5	1.5
AGP-2X/AGP	3.3	N/A	1.32	N/A

Notes:

1. V_{CCO} of GTL or GTLP should not be lower than the termination voltage or the voltage seen at the I/O pad.

Table 7: Supported Differential Signal I/O Standards

I/O Standard	Output V _{CCO}	Input V _{CCO}	Input V _{REF}	Output V _{OD}
LVPECL_33	3.3	N/A	N/A	490 mV to 1.22V
LDT_25	2.5	N/A	N/A	0.430 - 0.670
LVDS_33	3.3	N/A	N/A	0.250 - 0.400
LVDS_25	2.5	N/A	N/A	0.250 - 0.400
LVDS6EXT_33	3.3	N/A	N/A	0.330 - 0.700
LVDS6EXT_25	2.5	N/A	N/A	0.330 - 0.700
BLVDS_25	2.5	N/A	N/A	0.250 - 0.450
ULVDS_25	2.5	N/A	N/A	0.430 - 0.670

All of the user IOBs have fixed-clamp diodes to V_{CCO} and to ground. As outputs, these IOBs are not compatible or compliant with 5V I/O standards. As inputs, these IOBs are not normally 5V tolerant, but can be used with 5V I/O standards when external current-limiting resistors are used. For more details, see the “5V Tolerant I/Os” Tech Topic at <http://www.xilinx.com>.

Table 8 lists supported I/O standards with Digitally Controlled Impedance. See **Digitally Controlled Impedance (DCI)**, page 13.

Table 8: Supported DCI I/O Standards

I/O Standard	Output V _{CCO}	Input V _{CCO}	Input V _{REF}	Termination Type
LVDCI_33 ⁽¹⁾	3.3	3.3	N/A	Series
LVDCI_DV2_33 ⁽¹⁾	3.3	3.3	N/A	Series
LVDCI_25 ⁽¹⁾	2.5	2.5	N/A	Series
LVDCI_DV2_25 ⁽¹⁾	2.5	2.5	N/A	Series
LVDCI_18 ⁽¹⁾	1.8	1.8	N/A	Series
LVDCI_DV2_18 ⁽¹⁾	1.8	1.8	N/A	Series
LVDCI_15 ⁽¹⁾	1.5	1.5	N/A	Series
LVDCI_DV2_15 ⁽¹⁾	1.5	1.5	N/A	Series
GTL_DCI	1.2	1.2	0.8	Single
GTL_P_DCI	1.5	1.5	1.0	Single
HSTL_I_DCI	1.5	1.5	0.75	Split
HSTL_II_DCI	1.5	1.5	0.75	Split
HSTL_III_DCI	1.5	1.5	0.9	Single
HSTL_IV_DCI	1.5	1.5	0.9	Single
HSTL_I_DCI	1.8	N/A	0.9	Split
HSTL_II_DCI	1.8	N/A	0.9	Split
HSTL_III_DCI	1.8	N/A	1.1	Single
HSTL_IV_DCI	1.8	N/A	1.1	Single
SSTL2_I_DCI ⁽²⁾	2.5	2.5	1.25	Split
SSTL2_II_DCI ⁽²⁾	2.5	2.5	1.25	Split
SSTL3_I_DCI ⁽²⁾	3.3	3.3	1.5	Split
SSTL3_II_DCI ⁽²⁾	3.3	3.3	1.5	Split

Notes:

1. LVDCI_XX and LVDCI_DV2_XX are LVCMOS controlled impedance buffers, matching the reference resistors or half of the reference resistors.
2. These are SSTL compatible.

Logic Resources

IOB blocks include six storage elements, as shown in Figure 3.

Each storage element can be configured either as an edge-triggered D-type flip-flop or as a level-sensitive latch. On the input, output, and 3-state path, one or two DDR registers can be used.

Double data rate is directly accomplished by the two registers on each path, clocked by the rising edges (or falling edges) from two different clock nets. The two clock signals are generated by the DCM and must be 180 degrees out of phase, as shown in Figure 4. There are two input, output, and 3-state data signals, each being alternately clocked out.

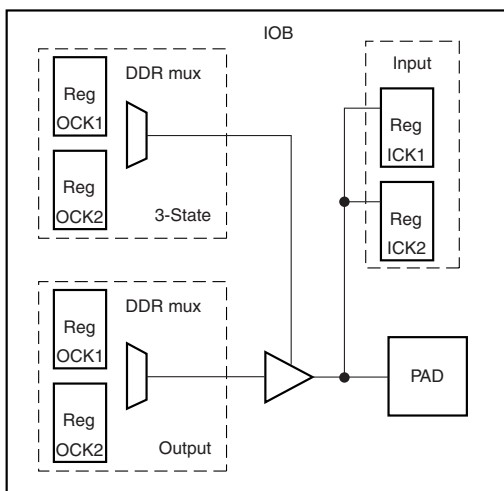

Figure 3: Virtex-II IOB Block

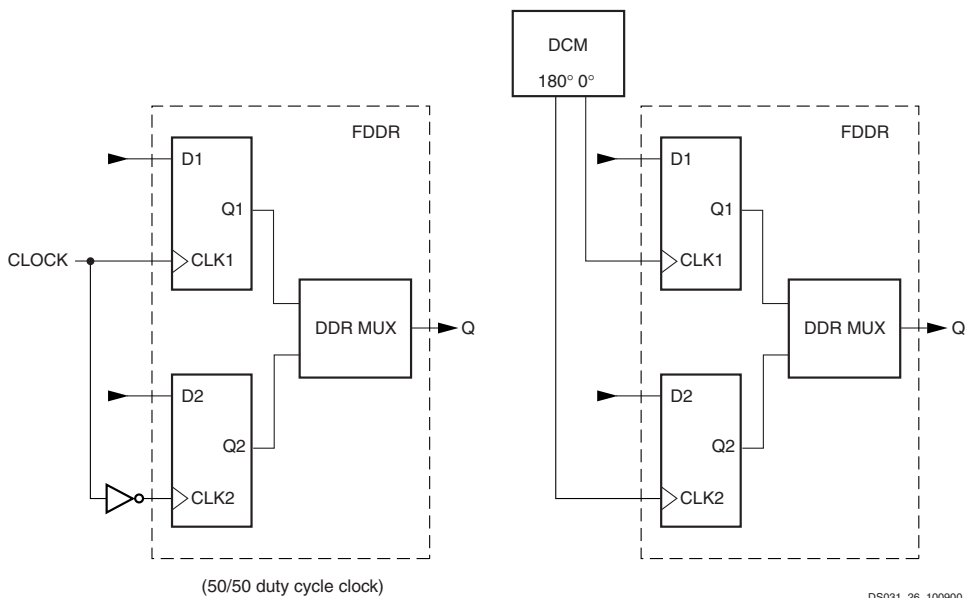

Figure 4: Double Data Rate Registers

DS031_26_100900

The DDR mechanism shown in Figure 4 can be used to mirror a copy of the clock on the output. This is useful for propagating a clock along the data that has an identical delay. It is also useful for multiple clock generation, where there is a unique clock driver for every clock load. Virtex-II devices can produce many copies of a clock with very little skew.

Each group of two registers has a clock enable signal (ICE for the input registers, OCE for the output registers, and TCE for the 3-state registers). The clock enable signals are active High by default. If left unconnected, the clock enable for that storage element defaults to the active state.

Each IOB block has common synchronous or asynchronous set and reset (SR and REV signals).

SR forces the storage element into the state specified by the SRHIGH or SRLOW attribute. SRHIGH forces a logic "1". SRLOW forces a logic "0". When SR is used, a second input (REV) forces the storage element into the opposite state. The reset condition predominates over the set condition. The initial state after configuration or global initialization state is defined by a separate INIT0 and INIT1 attribute. By default,

the SRLOW attribute forces INIT0, and the SRHIGH attribute forces INIT1.

For each storage element, the SRHIGH, SRLOW, INIT0, and INIT1 attributes are independent. Synchronous or asynchronous set/reset is consistent in an IOB block.

All the control signals have independent polarities. Any inverter placed on a control input is automatically absorbed.

Each register or latch (independent of all other registers or latches) (see Figure 5) can be configured as follows:

- No set or reset
- Synchronous set
- Synchronous reset
- Synchronous set and reset
- Asynchronous set (preset)
- Asynchronous reset (clear)
- Asynchronous set and reset (preset and clear)

The synchronous reset overrides a set, and an asynchronous clear overrides a preset.

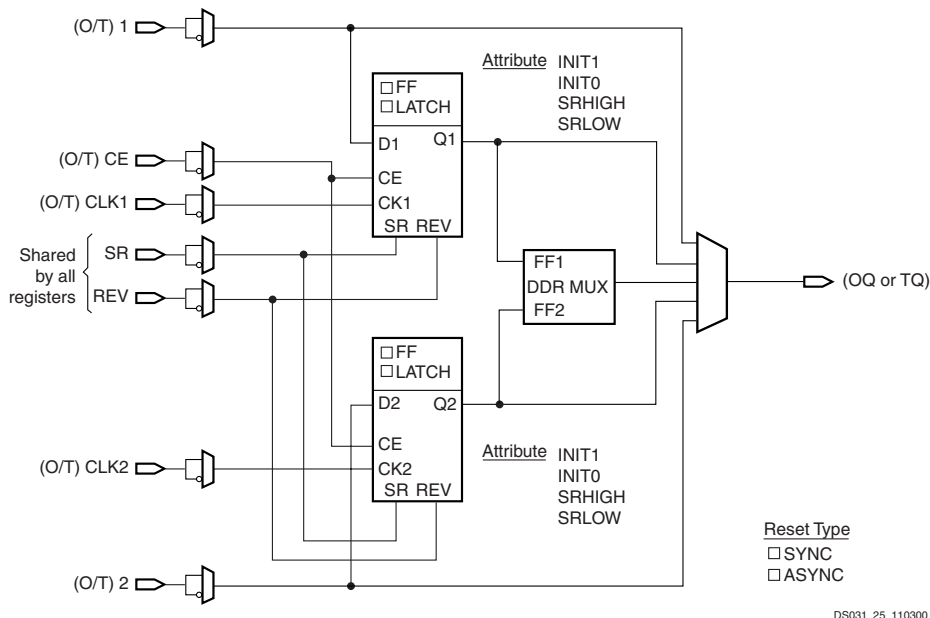

Figure 5: Register/Latch Configuration in an IOB Block

Input/Output Individual Options

Each device pad has optional pull-up and pull-down resistors in all SelectI/O-Ultra configurations. Each device pad has an optional weak-keeper in LVTTTL, LVCMOS, and PCI SelectI/O-Ultra configurations, as illustrated in Figure 6.

Values of the optional pull-up and pull-down resistors are in the range 10 - 60 KΩ, which is the specification for V_{CCO} when operating at 3.3V (from 3.0V to 3.6V only). The clamp diode is always present, even when power is not.

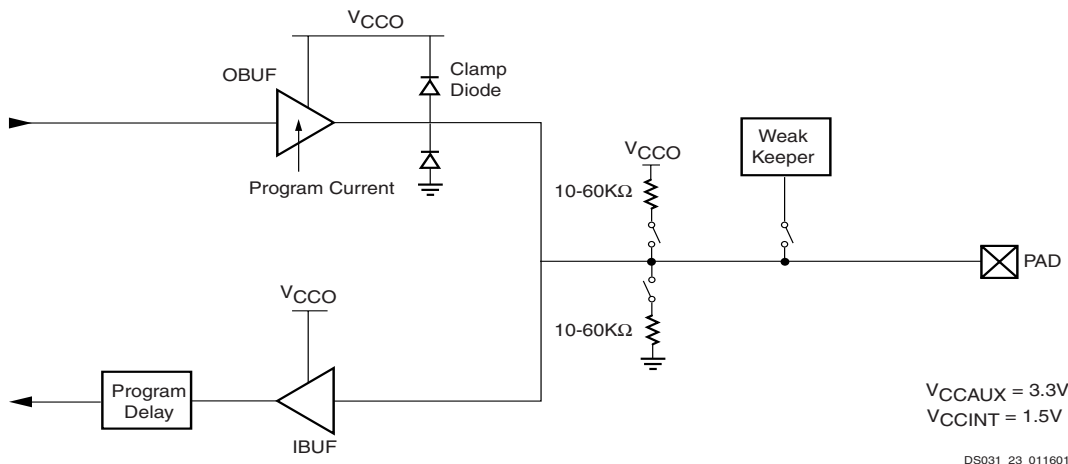

Figure 6: LVTTTL, LVCMOS, or PCI SelectI/O-Ultra Standards

The optional weak-keeper circuit is connected to each output. When selected, this circuit monitors the voltage on the pad and weakly drives the pin High or Low. If the pin is connected to a multiple-source signal, the weak-keeper holds the signal in its last state if all drivers are disabled. Maintaining a valid logic level in this way eliminates bus chatter. Pull-up or pull-down resistors override the weak-keeper circuit.

LVTTTL sinks and sources current up to 24 mA. The current is programmable for LVTTTL and LVCMOS SelectI/O-Ultra standards (see Table 9). Drive-strength and slew-rate controls for each output driver minimize bus transients. For LVDCI and LVDCI_DV2 standards, drive strength and slew-rate controls are not available.

Table 9: LVTTTL and LVCMOS Programmable Currents (Sink and Source)

SelectI/O-Ultra	Programmable Current (Worst-Case Guaranteed Minimum)						
LVTTTL	2 mA	4 mA	6 mA	8 mA	12 mA	16 mA	24 mA
LVCMOS33	2 mA	4 mA	6 mA	8 mA	12 mA	16 mA	24 mA
LVCMOS25	2 mA	4 mA	6 mA	8 mA	12 mA	16 mA	24 mA
LVCMOS18	2 mA	4 mA	6 mA	8 mA	12 mA	16 mA	n/a
LVCMOS15	2 mA	4 mA	6 mA	8 mA	12 mA	16 mA	n/a

Figure 7 shows the SSTL2, SSTL3, and HSTL configurations. HSTL can sink current up to 48 mA. (HSTL IV)

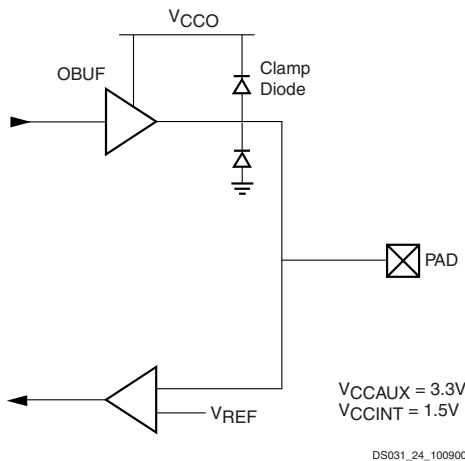

Figure 7: SSTL or HSTL SelectI/O-Ultra Standards

All pads are protected against damage from electrostatic discharge (ESD) and from over-voltage transients. Virtex-II devices use two memory cells to control the configuration of an I/O as an input. This is to reduce the probability of an I/O configured as an input from flipping to an output when subjected to a single event upset (SEU) in space applications.

Prior to configuration, all outputs not involved in configuration are forced into their high-impedance state. The pull-down resistors and the weak-keeper circuits are inactive. The dedicated pin HSWAP_EN controls the pull-up resistors prior to configuration. By default, HSWAP_EN is driven High, which disables the pull-up resistors on user I/O

pins. When HSWAP_EN is driven Low, the pull-up resistors are activated on user I/O pins.

All Virtex-II IOBs support IEEE 1149.1 compatible boundary-scan testing.

Input Path

The Virtex-II IOB input path routes input signals directly to internal logic and/or through an optional input flip-flop or latch, or through the DDR input registers. An optional delay element at the D-input of the storage element eliminates pad-to-pad hold time. The delay is matched to the internal clock-distribution delay of the Virtex-II device, and when used, ensures that the pad-to-pad hold time is zero.

Each input buffer can be configured to conform to any of the low-voltage signaling standards supported. In some of these standards the input buffer utilizes a user-supplied threshold voltage, VREF. The need to supply VREF imposes constraints on which standards can be used in the same bank. See I/O Banking description below.

Output Path

The output path includes a 3-state output buffer that drives the output signal onto the pad. The output and/or the 3-state signal can be routed to the buffer directly from the internal logic or through an output/3-state flip-flop or latch, or through the DDR output/3-state registers.

Each output driver can be individually programmed for a wide range of low-voltage signaling standards. In most signaling standards, the output High voltage depends on an externally supplied VCCO voltage. The need to supply VCCO imposes constraints on which standards can be used in the same bank. See I/O Banking description below.

I/O Banking

Some of the I/O standards described above require VCCO and VREF voltages. These voltages are externally supplied

and connected to device pins that serve groups of IOB blocks, called banks. Consequently, restrictions exist about which I/O standards can be combined within a given bank.

Eight I/O banks result from dividing each edge of the FPGA into two banks, as shown in Figure 8 and Figure 9. Each bank has multiple V_{CCO} pins, all of which must be connected to the same voltage. This voltage is determined by the output standards in use.

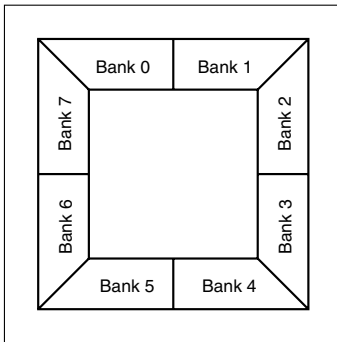

ug002_c2_014_112900

Figure 8: Virtex-II I/O Banks: Top View for Wire-Bond Packages (CS, FG, & BG)

Some input standards require a user-supplied threshold voltage (V_{REF}), and certain user-I/O pins are automatically configured as V_{REF} inputs. Approximately one in six of the I/O pins in the bank assume this role.

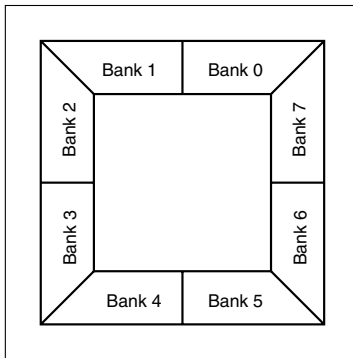

ds031_66_112900

Figure 9: Virtex-II I/O Banks: Top View for Flip-Chip Packages (FF & BF)

V_{REF} pins within a bank are interconnected internally, and consequently only one V_{REF} voltage can be used within each bank. However, for correct operation, all V_{REF} pins in the bank must be connected to the external reference voltage source.

The V_{CCO} and the V_{REF} pins for each bank appear in the device pinout tables. Within a given package, the number of

V_{REF} and V_{CCO} pins can vary depending on the size of device. In larger devices, more I/O pins convert to V_{REF} pins. Since these are always a superset of the V_{REF} pins used for smaller devices, it is possible to design a PCB that permits migration to a larger device if necessary.

All V_{REF} pins for the largest device anticipated must be connected to the V_{REF} voltage and are not used for I/O. In smaller devices, some V_{CCO} pins used in larger devices do not connect within the package. These unconnected pins can be left unconnected externally, or, if necessary, they can be connected to V_{CCO} to permit migration to a larger device.

Rules for Combining I/O Standards in the Same Bank

The following rules must be obeyed to combine different input, output, and bidirectional standards in the same bank:

1. **Combining output standards only.** Output standards with the same output V_{CCO} requirement can be combined in the same bank.
Compatible example:
 SSTL2_I and LVDS_25_DCI outputs
Incompatible example:
 SSTL2_I (output $V_{CCO} = 2.5V$) and LVC MOS33 (output $V_{CCO} = 3.3V$) outputs
2. **Combining input standards only.** Input standards with the same input V_{CCO} and input V_{REF} requirements can be combined in the same bank.

- Compatible example:*
 LVC MOS15 and HSTL_IV inputs
Incompatible example:
 LVC MOS15 (input $V_{CCO} = 1.5V$) and LVC MOS18 (input $V_{CCO} = 1.8V$) inputs
Incompatible example:
 HSTL_I_DCI_18 ($V_{REF} = 0.9V$) and HSTL_IV_DCI_18 ($V_{REF} = 1.1V$) inputs

3. **Combining input standards and output standards.** Input standards and output standards with the same input V_{CCO} and output V_{CCO} requirement can be combined in the same bank.

- Compatible example:*
 LVDS_25 output and HSTL_I input
Incompatible example:
 LVDS_25 output (output $V_{CCO} = 2.5V$) and HSTL_I_DCI_18 input (input $V_{CCO} = 1.8V$)

4. **Combining bidirectional standards with input or output standards.** When combining bidirectional I/O with other standards, make sure the bidirectional standard can meet rules 1 through 3 above.

5. **Additional rules for combining DCI I/O standards.**
 - a. No more than one Single Termination type (input or output) is allowed in the same bank.
Incompatible example:
 HSTL_IV_DCI input and HSTL_III_DCI input
 - b. No more than one Split Termination type (input or output) is allowed in the same bank.

Incompatible example:

HSTL_I_DCI input and HSTL_II_DCI input

Table 10 summarizes all standards and voltage supplies.

Table 10: Summary of Voltage Supply Requirements for All Input and Output Standards

I/O Standard	V _{CCO}		V _{REF}			Termination Type				
	Output	Input	Input	Output	Input	Output	Input	Input		
LVDS_33	3.3	N/R	N/R ⁽¹⁾	N/R	N/R					
LVDS_33			N/R	N/R	N/R					
LVPECL_33			N/R	N/R	N/R					
SSTL3_I			1.5	N/R	N/R					
SSTL3_II			1.5	N/R	N/R					
AGP			1.32	N/R	N/R					
LVTTTL		3.3	N/R	N/R	N/R	N/R				
LVCOS33				N/R	N/R	N/R				
LVDCI_33				N/R	Series	N/R				
LVDCI_DV2_33				N/R	Series	N/R				
PCI33_3			3.3	N/R	N/R	N/R	N/R			
PCI66_3					N/R	N/R	N/R			
PCIX					N/R	N/R	N/R			
LVDS_33_DCI					N/R	N/R	Split			
LVDS_33_DCI					N/R	N/R	Split			
SSTL3_I_DCI					1.5	N/R	Split			
SSTL3_II_DCI	1.5	Split	Split							
LVDS_25	2.5	N/R	N/R	N/R	N/R					
LVDS_25			N/R	N/R	N/R					
LDT_25			N/R	N/R	N/R					
ULVDS_25			N/R	N/R	N/R					
BLVDS_25			N/R	N/R	N/R					
SSTL2_I			1.25	N/R	N/R					
SSTL2_II		1.25	N/R	N/R						
LVCOS25		2.5	N/R	N/R	N/R	N/R				
LVDCI_25				N/R	Series	N/R				
LVDCI_DV2_25				N/R	Series	N/R				
LVDS_25_DCI				N/R	N/R	Split				
LVDS_25_DCI			2.5	N/R	N/R	N/R	Split			
SSTL2_I_DCI					1.25	N/R	Split			
SSTL2_II_DCI					1.25	Split	Split			

The implementation tools will enforce these design rules.

Table 10: Summary of Voltage Supply Requirements for All Input and Output Standards (Continued)

I/O Standard	V _{CCO}		V _{REF}			Termination Type				
	Output	Input	Input	Output	Input	Output	Input	Input		
HSTL_III_18	1.8	N/R	1.1	N/R	N/R					
HSTL_IV_18			1.1	N/R	N/R					
HSTL_I_18			0.9	N/R	N/R					
HSTL_II_18			0.9	N/R	N/R					
SSTL18_I			0.9	N/R	N/R					
SSTL18_II			0.9	N/R	N/R					
LVCOS18		1.8	N/R	N/R	N/R	N/R				
LVDCI_18				N/R	Series	N/R				
LVDCI_DV2_18				N/R	Series	N/R				
HSTL_III_DCI_18				1.1	N/R	Single				
HSTL_IV_DCI_18			1.1	Single	Single					
HSTL_I_DCI_18			0.9	N/R	Split					
HSTL_II_DCI_18			0.9	Split	Split					
SSTL18_I_DCI			0.9	N/R	Split					
SSTL18_II_DCI			0.9	Split	Split					
HSTL_III			1.5	N/R	0.9	N/R	N/R			
HSTL_IV	0.9	N/R			N/R					
HSTL_I	0.75	N/R			N/R					
HSTL_II	0.75	N/R			N/R					
LVCOS15	1.5	N/R		N/R	N/R	N/R				
LVDCI_15				N/R	Series	N/R				
LVDCI_DV2_15				N/R	Series	N/R				
GTL_P_DCI				1	Single	Single				
HSTL_III_DCI		0.9		N/R	Single					
HSTL_IV_DCI		0.9		Single	Single					
HSTL_I_DCI		0.75		N/R	Split					
HSTL_II_DCI		0.75		Split	Split					
GTL_DCI		1.2		1.2	0.8	Single	Single			
GTL_P		N/R		N/R	1	N/R	N/R			
GTL	0.8				N/R	N/R				

Notes:

- 1. N/R = no requirement.

Digitally Controlled Impedance (DCI)

Today's chip output signals with fast edge rates require termination to prevent reflections and maintain signal integrity.

High pin count packages (especially ball grid arrays) can not accommodate external termination resistors.

Virtex-II XCITE DCI provides controlled impedance drivers and on-chip termination for single-ended and differential I/Os. This eliminates the need for external resistors, and improves signal integrity. The DCI feature can be used on any IOB by selecting one of the DCI I/O standards.

When applied to inputs, DCI provides input parallel termination. When applied to outputs, DCI provides controlled impedance drivers (series termination) or output parallel termination.

DCI operates independently on each I/O bank. When a DCI I/O standard is used in a particular I/O bank, external reference resistors must be connected to two dual-function pins on the bank. These resistors, the voltage reference of the N transistor (VRN), and the voltage reference of the P transistor (VRP) are shown in [Figure 10](#).

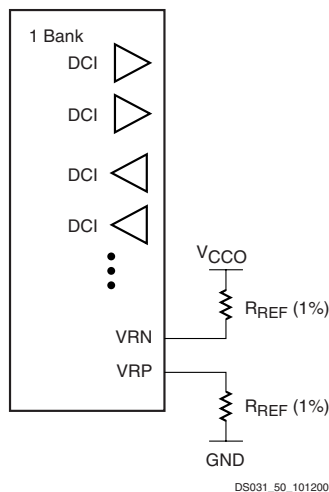

Figure 10: DCI in a Virtex-II Bank

When used with a terminated I/O standard, the value of resistors are specified by the standard (typically 50 Ω). When used with a controlled impedance driver, the resistors set the output impedance of the driver within the specified range (25 Ω to 100 Ω). For all series and parallel terminations listed in [Table 11](#) and [Table 12](#), the reference resistors must have the same value for any given bank. One percent resistors are recommended.

The DCI system adjusts the I/O impedance to match the two external reference resistors or half of the reference resistors, and compensates for impedance changes due to voltage and/or temperature fluctuations. The adjustment is done by turning parallel transistors in the IOB on or off.

Controlled Impedance Drivers (Series Termination)

DCI can be used to provide a buffer with a controlled output impedance. It is desirable for this output impedance to match the transmission line impedance (Z). Virtex-II input buffers also support LVDCI and LVDCI_DV2 I/O standards.

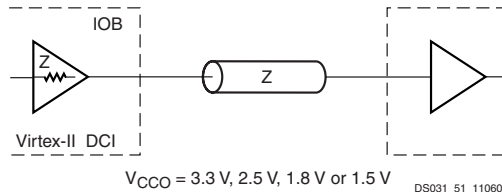

Figure 11: Internal Series Termination

Table 11: SelectI/O-Ultra Controlled Impedance Buffers

V _{CCO}	DCI	DCI Half Impedance
3.3 V	LVDCI_33	LVDCI_DV2_33
2.5 V	LVDCI_25	LVDCI_DV2_25
1.8 V	LVDCI_18	LVDCI_DV2_18
1.5 V	LVDCI_15	LVDCI_DV2_15

Controlled Impedance Drivers (Parallel Termination)

DCI also provides on-chip termination for SSTL3, SSTL2, HSTL (Class I, II, III, or IV), and GTL/GTLP receivers or transmitters on bidirectional lines.

[Table 12](#) lists the on-chip parallel terminations available in Virtex-II devices. V_{CCO} must be set according to [Table 8](#). Note that there is a V_{CCO} requirement for GTL_DCI and GTLP_DCI, due to the on-chip termination resistor.

Table 12: SelectI/O-Ultra Buffers with On-Chip Parallel Termination

I/O Standard	External Termination	On-Chip Termination
SSTL3 Class I	SSTL3_I	SSTL3_I_DCI ⁽¹⁾
SSTL3 Class II	SSTL3_II	SSTL3_II_DCI ⁽¹⁾
SSTL2 Class I	SSTL2_I	SSTL2_I_DCI ⁽¹⁾
SSTL2 Class II	SSTL2_II	SSTL2_II_DCI ⁽¹⁾
HSTL Class I	HSTL_I	HSTL_I_DCI
HSTL Class II	HSTL_II	HSTL_II_DCI
HSTL Class III	HSTL_III	HSTL_III_DCI
HSTL Class IV	HSTL_IV	HSTL_IV_DCI

Table 12: Select I/O-Ultra Buffers with On-Chip Parallel Termination (Continued)

I/O Standard	External Termination	On-Chip Termination
GTL	GTL	GTL_DCI
GTLP	GTLP	GTLP_DCI

Notes:

- SSTL Compatible

Figure 12 provides examples illustrating the use of the HSTL_I_DCI, HSTL_II_DCI, HSTL_III_DCI, and HSTL_IV_DCI I/O standards. For a complete list, see the Virtex-II User Guide (UG002).

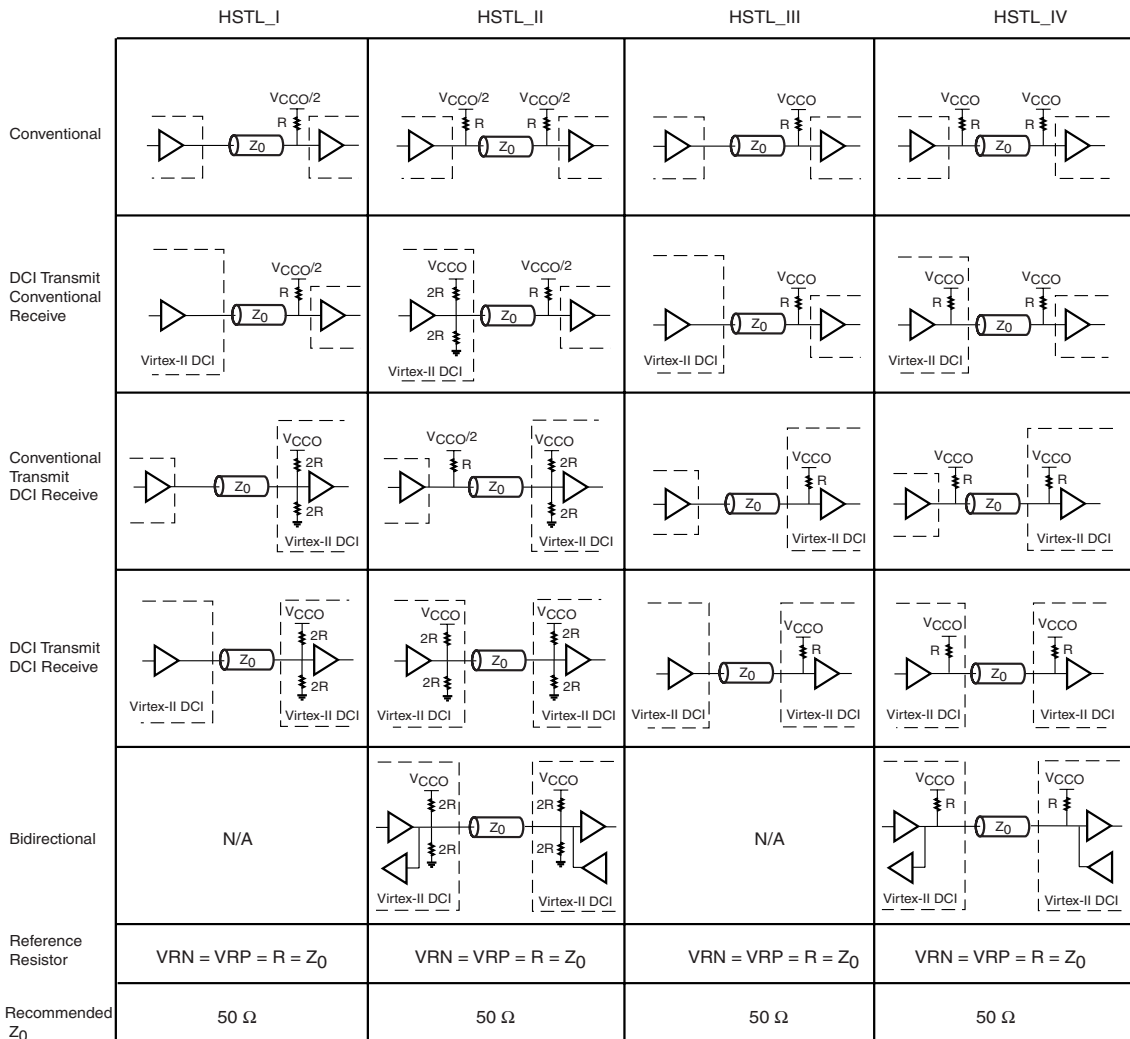

DS031_65a_100201

Figure 12: HSTL DCI Usage Examples

Figure 13 provides examples illustrating the use of the SSTL2_I_DCI, SSTL2_II_DCI, SSTL3_I_DCI, and SSTL3_II_DCI I/O standards. For a complete list, see the *Virtex-II User Guide* (UG002).

	SSTL2_I	SSTL2_II	SSTL3_I	SSTL3_II
Conventional				
DCI Transmit Conventional Receive				
Conventional Transmit DCI Receive				
DCI Transmit DCI Receive				
Bidirectional	N/A		N/A	
Reference Resistor	$VRN = VRP = R = Z_0$	$VRN = VRP = R = Z_0$	$VRN = VRP = R = Z_0$	$VRN = VRP = R = Z_0$
Recommended $Z_0^{(2)}$	50 Ω	50 Ω	50 Ω	50 Ω

Notes:

1. The SSTL-compatible 25 Ω series resistor is accounted for in the DCI buffer, and it is not DCI controlled.
2. Z_0 is the recommended PCB trace impedance.

DS031_65b_112502

Figure 13: SSTL DCI Usage Examples

Figure 14 provides examples illustrating the use of the LVDS_DCI and LVDS_EXT_DCI I/O standards. For a complete list, see the *Virtex-II User Guide* ([UG002](#)).

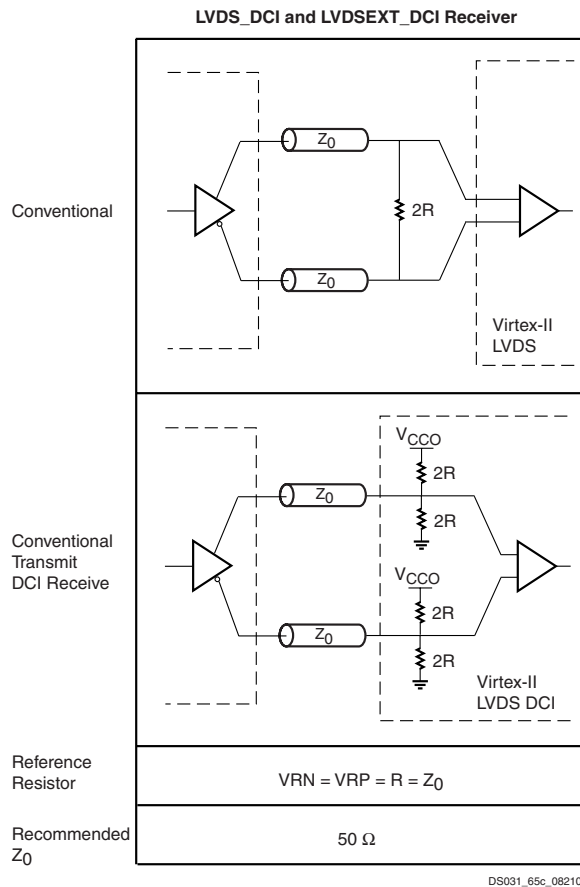

Figure 14: LVDS DCI Usage Examples

Configurable Logic Blocks (CLBs)

The Virtex-II configurable logic blocks (CLB) are organized in an array and are used to build combinatorial and synchronous logic designs. Each CLB element is tied to a switch matrix to access the general routing matrix, as shown in [Figure 15](#). A CLB element comprises four similar slices with fast local feedback within the CLB. The four slices are split into two columns of two slices with two independent carry chains and one common shift chain.

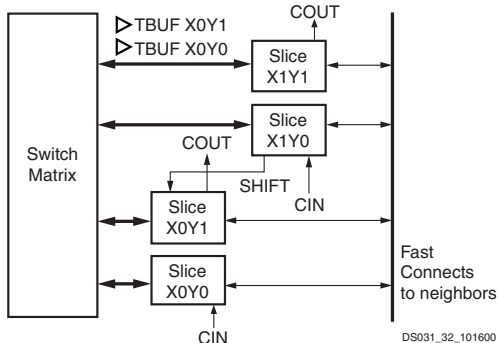

Figure 15: Virtex-II CLB Element

Slice Description

Each slice includes two 4-input function generators, carry logic, arithmetic logic gates, wide function multiplexers and two storage elements. As shown in [Figure 16](#), each 4-input function generator is programmable as a 4-input LUT, 16 bits of distributed SelectRAM memory, or a 16-bit variable-tap shift register element.

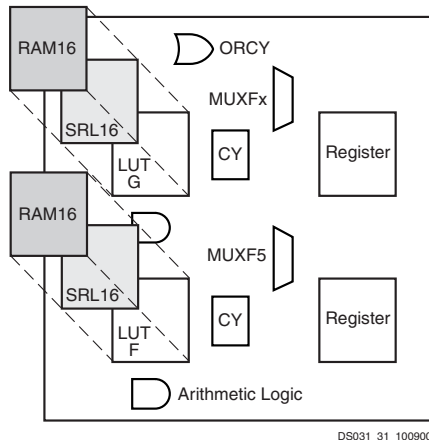

Figure 16: Virtex-II Slice Configuration

The output from the function generator in each slice drives both the slice output and the D input of the storage element. [Figure 17](#) shows a more detailed view of a single slice.

Configurations

Look-Up Table

Virtex-II function generators are implemented as 4-input look-up tables (LUTs). Four independent inputs are provided to each of the two function generators in a slice (F and G). These function generators are each capable of implementing any arbitrarily defined Boolean function of four inputs. The propagation delay is therefore independent of the function implemented. Signals from the function generators can exit the slice (X or Y output), can input the XOR dedicated gate (see arithmetic logic), or input the carry-logic multiplexer (see fast look-ahead carry logic), or feed the D input of the storage element, or go to the MUXF5 (not shown in [Figure 17](#)).

In addition to the basic LUTs, the Virtex-II slice contains logic (MUXF5 and MUXFX multiplexers) that combines function generators to provide any function of five, six, seven, or eight inputs. The MUXFXs are either MUXF6, MUXF7, or MUXF8 according to the slice considered in the CLB. Selected functions up to nine inputs (MUXF5 multiplexer) can be implemented in one slice. The MUXFX can also be a MUXF6, MUXF7, or MUXF8 multiplexer to map any functions of six, seven, or eight inputs and selected wide logic functions.

Register/Latch

The storage elements in a Virtex-II slice can be configured as either edge-triggered D-type flip-flops or level-sensitive latches. The D input can be directly driven by the X or Y output via the DX or DY input, or by the slice inputs bypassing the function generators via the BX or BY input. The clock enable signal (CE) is active High by default. If left unconnected, the clock enable for that storage element defaults to the active state.

In addition to clock (CK) and clock enable (CE) signals, each slice has set and reset signals (SR and BY slice inputs). SR forces the storage element into the state specified by the attribute SRHIGH or SRLOW. SRHIGH forces a logic "1" when SR is asserted. SRLOW forces a logic "0". When SR is used, a second input (BY) forces the storage element into the opposite state. The reset condition is predominant over the set condition. (See [Figure 18](#).)

The initial state after configuration or global initial state is defined by a separate INIT0 and INIT1 attribute. By default, setting the SRLOW attribute sets INIT0, and setting the SRHIGH attribute sets INIT1.

For each slice, set and reset can be set to be synchronous or asynchronous. Virtex-II devices also have the ability to set INIT0 and INIT1 independent of SRHIGH and SRLOW. Control signals CLK, CE, and SR are common to both storage elements in one slice. All control signals have independent polarities. Any inverter placed on a control input is automatically absorbed.

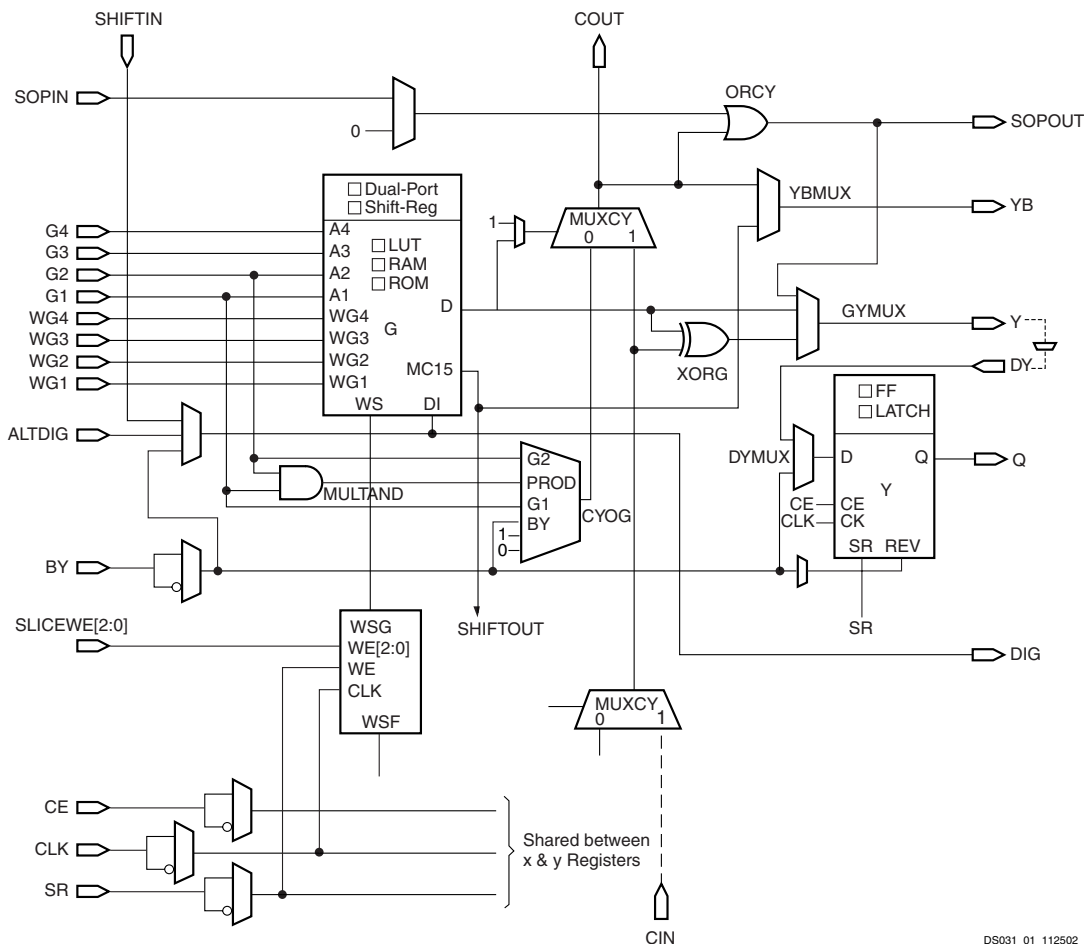

DS031_01_112502

Figure 17: Virtex-II Slice (Top Half)

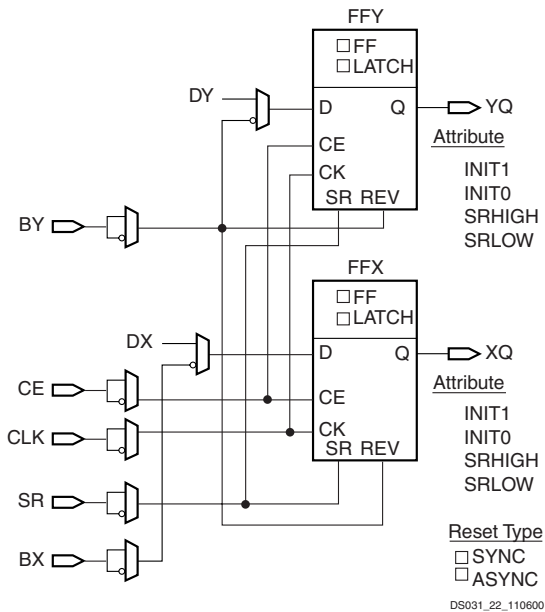

Figure 18: Register/Latch Configuration in a Slice

The set and reset functionality of a register or a latch can be configured as follows:

- No set or reset
- Synchronous set
- Synchronous reset
- Synchronous set and reset
- Asynchronous set (preset)
- Asynchronous reset (clear)
- Asynchronous set and reset (preset and clear)

The synchronous reset has precedence over a set, and an asynchronous clear has precedence over a preset.

Distributed SelectRAM Memory

Each function generator (LUT) can implement a 16 x 1-bit synchronous RAM resource called a distributed SelectRAM element. The SelectRAM elements are configurable within a CLB to implement the following:

- Single-Port 16 x 8 bit RAM
- Single-Port 32 x 4 bit RAM
- Single-Port 64 x 2 bit RAM
- Single-Port 128 x 1 bit RAM

- Dual-Port 16 x 4 bit RAM
- Dual-Port 32 x 2 bit RAM
- Dual-Port 64 x 1 bit RAM

Distributed SelectRAM memory modules are synchronous (write) resources. The combinatorial read access time is extremely fast, while the synchronous write simplifies high-speed designs. A synchronous read can be implemented with a storage element in the same slice. The distributed SelectRAM memory and the storage element share the same clock input. A Write Enable (WE) input is active High, and is driven by the SR input.

Table 13 shows the number of LUTs (2 per slice) occupied by each distributed SelectRAM configuration.

Table 13: Distributed SelectRAM Configurations

RAM	Number of LUTs
16 x 1S	1
16 x 1D	2
32 x 1S	2
32 x 1D	4
64 x 1S	4
64 x 1D	8
128 x 1S	8

Notes:

1. S = single-port configuration, and D = dual-port configuration.

For single-port configurations, distributed SelectRAM memory has one address port for synchronous writes and asynchronous reads.

For dual-port configurations, distributed SelectRAM memory has one port for synchronous writes and asynchronous reads and another port for asynchronous reads. The function generator (LUT) has separated read address inputs (A1, A2, A3, A4) and write address inputs (WG1/WF1, WG2/WF2, WG3/WF3, WG4/WF4).

In single-port mode, read and write addresses share the same address bus. In dual-port mode, one function generator (R/W port) is connected with shared read and write addresses. The second function generator has the A inputs (read) connected to the second read-only port address and the W inputs (write) shared with the first read/write port address.

Figure 19, Figure 20, and Figure 21 illustrate various example configurations.

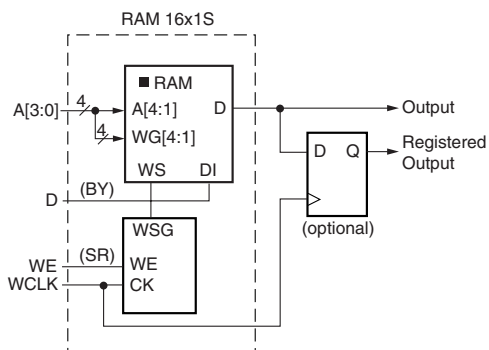

DS031_02_110303

Figure 19: Distributed SelectRAM (RAM16x1S)

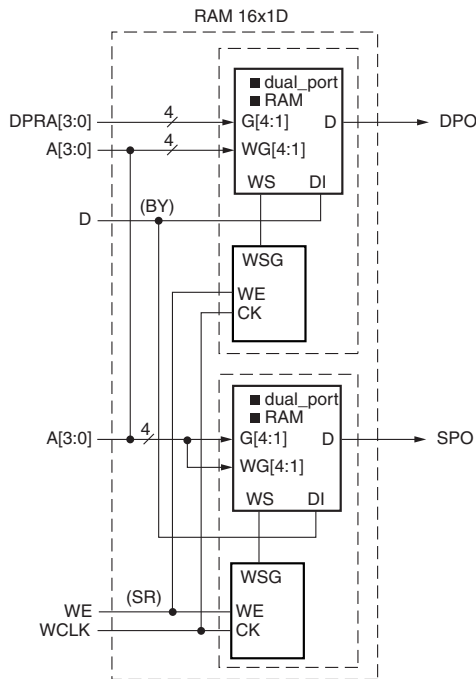

DS031_04_110100

Figure 21: Dual-Port Distributed SelectRAM (RAM16x1D)

Similar to the RAM configuration, each function generator (LUT) can implement a 16 x 1-bit ROM. Five configurations are available: ROM16x1, ROM32x1, ROM64x1, ROM128x1, and ROM256x1. The ROM elements are cascable to implement wider or/and deeper ROM. ROM contents are loaded at configuration. Table 14 shows the number of LUTs occupied by each configuration.

Table 14: ROM Configuration

ROM	Number of LUTs
16 x 1	1
32 x 1	2
64 x 1	4
128 x 1	8 (1 CLB)
256 x 1	16 (2 CLBs)

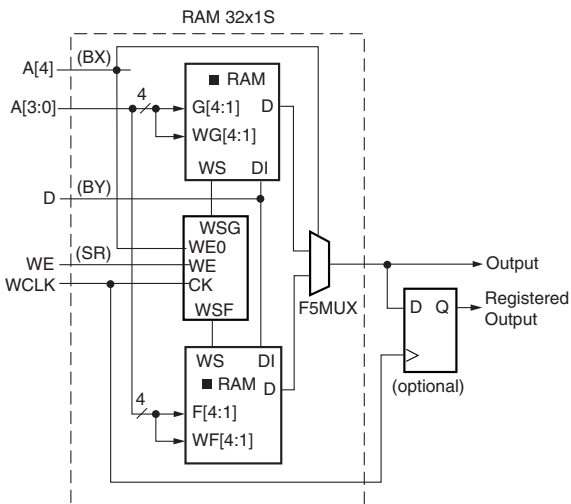

DS031_03_110100

Figure 20: Single-Port Distributed SelectRAM (RAM32x1S)

Shift Registers

Each function generator can also be configured as a 16-bit shift register. The write operation is synchronous with a clock input (CLK) and an optional clock enable, as shown in Figure 22. A dynamic read access is performed through the 4-bit address bus, A[3:0]. The configurable 16-bit shift register cannot be set or reset. The read is asynchronous, however, the storage element or flip-flop is available to implement a synchronous read. The storage element should always be used with a constant address. For example, when building an 8-bit shift register and configuring the addresses to point to the seventh bit, the eighth bit can be the flip-flop. The overall system performance is improved by using the superior clock-to-out of the flip-flops.

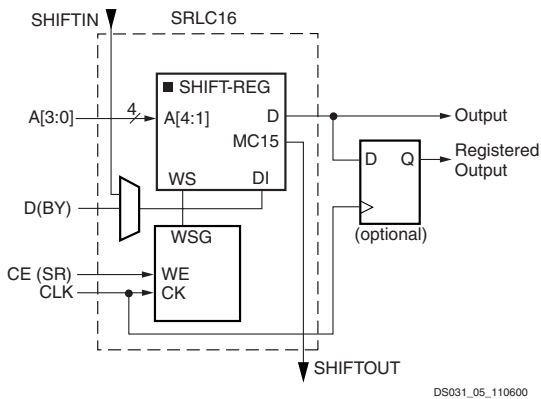

Figure 22: Shift Register Configurations

An additional dedicated connection between shift registers allows connecting the last bit of one shift register to the first bit of the next, without using the ordinary LUT output. (See Figure 23.) Longer shift registers can be built with dynamic access to any bit in the chain. The shift register chaining and the MUXF5, MUXF6, and MUXF7 multiplexers allow up to a 128-bit shift register with addressable access to be implemented in one CLB.

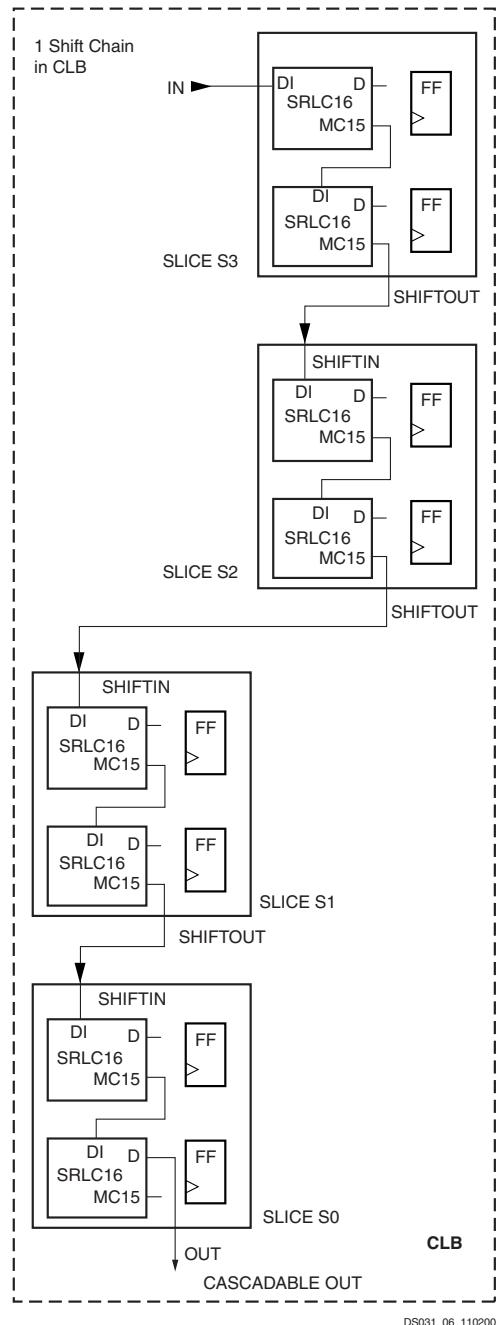

Figure 23: Cascadable Shift Register

Multiplexers

Virtex-II function generators and associated multiplexers can implement the following:

- 4:1 multiplexer in one slice
- 8:1 multiplexer in two slices
- 16:1 multiplexer in one CLB element (4 slices)
- 32:1 multiplexer in two CLB elements (8 slices)

Each Virtex-II slice has one MUXF5 multiplexer and one MUXFX multiplexer. The MUXFX multiplexer implements the MUXF6, MUXF7, or MUXF8, as shown in **Figure 24**. Each CLB element has two MUXF6 multiplexers, one MUXF7 multiplexer and one MUXF8 multiplexer. Examples of multiplexers are shown in the *Virtex-II User Guide* ([UG002](#)). Any LUT can implement a 2:1 multiplexer.

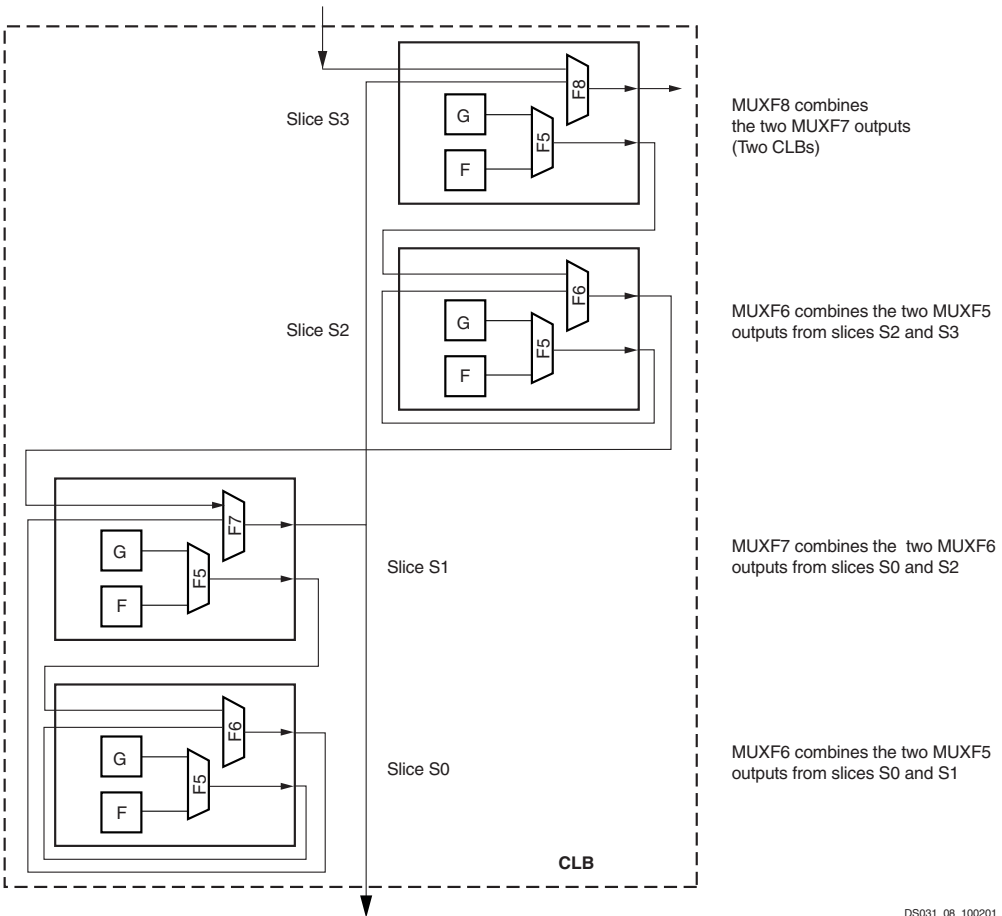

Figure 24: MUXF5 and MUXFX multiplexers

DS031_08_100201

Fast Lookahead Carry Logic

Dedicated carry logic provides fast arithmetic addition and subtraction. The Virtex-II CLB has two separate carry chains, as shown in the **Figure 25**.

The height of the carry chains is two bits per slice. The carry chain in the Virtex-II device is running upward. The dedicated carry path and carry multiplexer (MUXCY) can also

be used to cascade function generators for implementing wide logic functions.

Arithmetic Logic

The arithmetic logic includes an XOR gate that allows a 2-bit full adder to be implemented within a slice. In addition, a dedicated AND (MULT_AND) gate (shown in **Figure 17**) improves the efficiency of multiplier implementation.

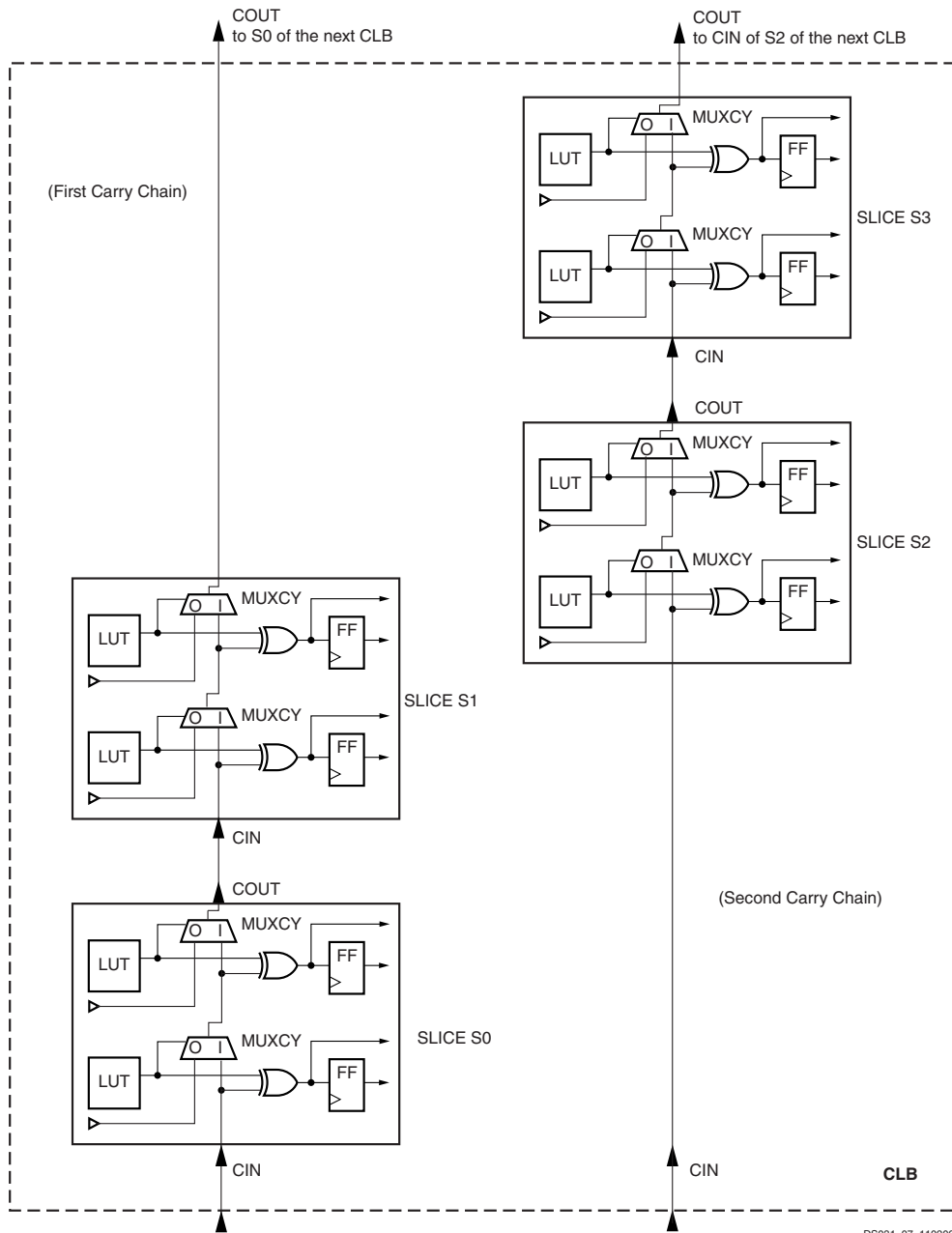

Figure 25: Fast Carry Logic Path

Sum of Products

Each Virtex-II slice has a dedicated OR gate named ORCY, ORing together outputs from the slices carryout and the ORCY from an adjacent slice. The ORCY gate with the dedicated Sum of Products (SOP) chain are designed for implementing large, flexible SOP chains. One input of each ORCY is connected through the fast SOP chain to the output of the previous ORCY in the same slice row. The second input is connected to

the output of the top MUXCY in the same slice, as shown in Figure 26.

LUTs and MUXCYs can implement large AND gates or other combinatorial logic functions. Figure 27 illustrates LUT and MUXCY resources configured as a 16-input AND gate.

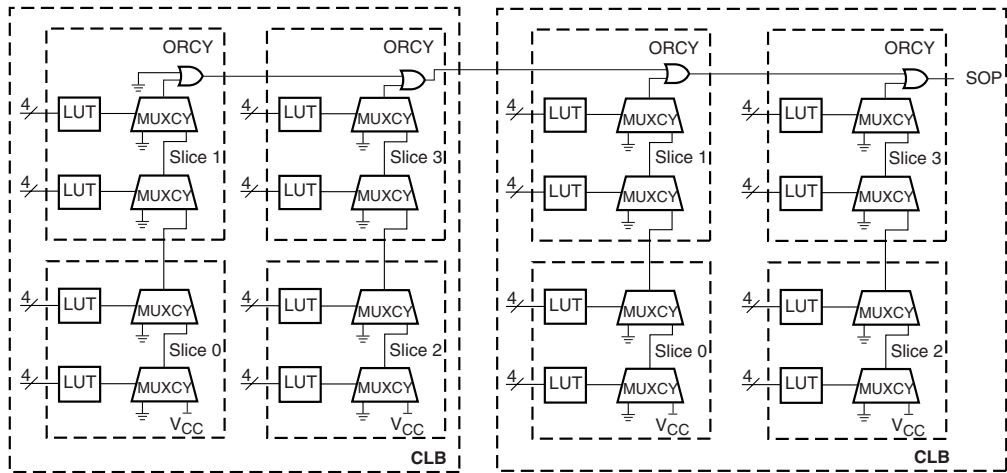

Figure 26: Horizontal Cascade Chain

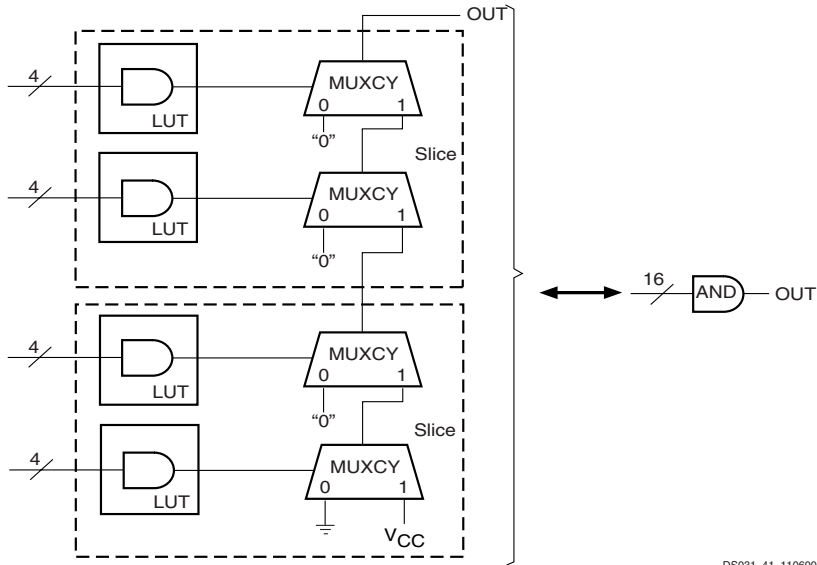

Figure 27: Wide-Input AND Gate (16 Inputs)

3-State Buffers

Introduction

Each Virtex-II CLB contains two 3-state drivers (TBUFs) that can drive on-chip buses. Each 3-state buffer has its own 3-state control pin and its own input pin.

Each of the four slices have access to the two 3-state buffers through the switch matrix, as shown in Figure 28. TBUFs in neighboring CLBs can access slice outputs by direct connects. The outputs of the 3-state buffers drive horizontal routing resources used to implement 3-state buses.

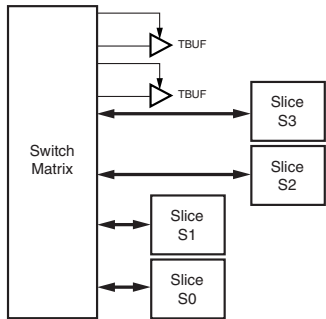

DS031_37_060700

Figure 28: Virtex-II 3-State Buffers

The 3-state buffer logic is implemented using AND-OR logic rather than 3-state drivers, so that timing is more predictable and less load dependent especially with larger devices.

Locations/Organization

Four horizontal routing resources per CLB are provided for on-chip 3-state buses. Each 3-state buffer has access alternately to two horizontal lines, which can be partitioned as shown in Figure 29. The switch matrices corresponding to SelectRAM memory and multiplier or I/O blocks are skipped.

Number of 3-State Buffers

Table 15 shows the number of 3-state buffers available in each Virtex-II device. The number of 3-state buffers is twice the number of CLB elements.

Table 15: Virtex-II 3-State Buffers

Device	3-State Buffers per Row	Total Number of 3-State Buffers
XQ2V1000	64	2,560
XQ2V3000	112	7,168
XQ2V6000	176	16,896

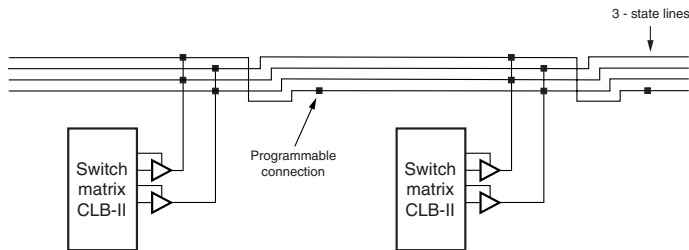

DS031_09_032700

Figure 29: 3-State Buffer Connection to Horizontal Lines

CLB/Slice Configurations

Table 16 summarizes the logic resources in one CLB. All of the CLBs are identical and each CLB or slice can be imple-

mented in one of the configurations listed. Table 17 shows the available resources in all CLBs.

Table 16: Logic Resources in One CLB

Slices	LUTs	Flip-Flops	MULT_ANDs	Arithmetic & Carry Chains	SOP Chains	Distributed SelectRAM	Shift Registers	TBUF
4	8	8	8	2	2	128 bits	128 bits	2

Table 17: Virtex-II Logic Resources Available in All CLBs

Device	CLB Array: Row x Column	Number of Slices	Number of LUTs	Max Distributed SelectRAM or Shift Register (bits)	Number of Flip-Flops	Number of Carry Chains ⁽¹⁾	Number of SOP Chains ⁽¹⁾
XQ2V1000	40 x 32	5,120	10,240	163,840	10,240	64	80
XQ2V3000	64 x 56	14,336	28,672	458,752	28,672	112	128
XQ2V6000	96 x 88	33,792	67,584	1,081,344	67,584	176	192

Notes:

1. The carry chains and SOP chains can be split or cascaded.

18 Kbit Block SelectRAM Resources

Introduction

Virtex-II devices incorporate large amounts of 18 Kbit block SelectRAM. These complement the distributed SelectRAM resources that provide shallow RAM structures implemented in CLBs. Each Virtex-II block SelectRAM is an 18 Kbit true dual-port RAM with two independently clocked and independently controlled synchronous ports that access a common storage area. Both ports are functionally identical. CLK, EN, WE, and SSR polarities are defined through configuration.

Each port has the following types of inputs: Clock and Clock Enable, Write Enable, Set/Reset, and Address, as well as separate Data/parity data inputs (for writes) and Data/parity data outputs (for reads).

Operation is synchronous. The block SelectRAM behaves like a register. Control, address, and data inputs must (and need only) be valid during the set-up time window prior to a rising (or falling, as a configuration option) clock edge. Data outputs change as a result of the same clock edge.

Configuration

The Virtex-II block SelectRAM supports various configurations, including single- and dual-port RAM and various data/address aspect ratios. Supported memory configurations for single- and dual-port modes are shown in Table 18.

Table 18: Dual- and Single-Port Configurations

16K x 1 bit	2K x 9 bits
8K x 2 bits	1K x 18 bits
4K x 4 bits	512 x 36 bits

Single-Port Configuration

As a single-port RAM, the block SelectRAM has access to the 18 Kbit memory locations in any of the 2K x 9-bit,

1K x 18-bit, or 512 x 36-bit configurations and to 16 Kbit memory locations in any of the 16K x 1-bit, 8K x 2-bit, or 4K x 4-bit configurations. The advantage of 9-bit, 18-bit, and 36-bit widths is the ability to store a parity bit for every eight bits. Parity bits must be generated or checked externally in user logic. In such cases, the width is viewed as 8 + 1, 16 + 2, or 32 + 4. These extra parity bits are stored and behave exactly as the other bits, including the timing parameters. Video applications can use the 9-bit ratio of Virtex-II block SelectRAM memory to advantage.

Each block SelectRAM cell is a fully synchronous memory, as illustrated in Figure 30. Input data bus and output data bus widths are identical.

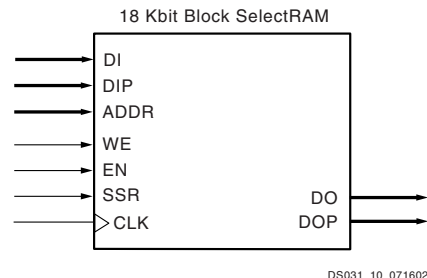

Figure 30: 18 Kbit Block SelectRAM Memory in Single-Port Mode

Dual-Port Configuration

As a dual-port RAM, each port of block SelectRAM has access to a common 18 Kbit memory resource. These are fully synchronous ports with independent control signals for each port. The data widths of the two ports can be configured independently, providing built-in bus-width conversion.

Table 19 illustrates the different configurations available on Ports A and B.

Table 19: Dual-Port Mode Configurations

Port A	16K x 1	16K x 1	16K x 1	16K x 1	16K x 1	16K x 1
Port B	16K x 1	8K x 2	4K x 4	2K x 9	1K x 18	512 x 36
Port A	8K x 2	8K x 2	8K x 2	8K x 2	8K x 2	
Port B	8K x 2	4K x 4	2K x 9	1K x 18	512 x 36	
Port A	4K x 4	4K x 4	4K x 4	4K x 4		
Port B	4K x 4	2K x 9	1K x 18	512 x 36		
Port A	2K x 9	2K x 9	2K x 9			
Port B	2K x 9	1K x 18	512 x 36			
Port A	1K x 18	1K x 18				
Port B	1K x 18	512 x 36				
Port A	512 x 36					
Port B	512 x 36					

If both ports are configured in either 2K x 9-bit, 1K x 18-bit, or 512 x 36-bit configurations, the 18 Kbit block is accessible from Port A or B. If both ports are configured in either 16K x 1-bit, 8K x 2-bit, or 4K x 4-bit configurations, the 16 Kbit block is accessible from Port A or Port B. All other configurations result in one port having access to an 18 Kbit memory block and the other port having access to a 16 Kbit subset of the memory block equal to 16 Kbits.

Each block SelectRAM cell is a fully synchronous memory, as illustrated in Figure 31. The two ports have independent inputs and outputs and are independently clocked.

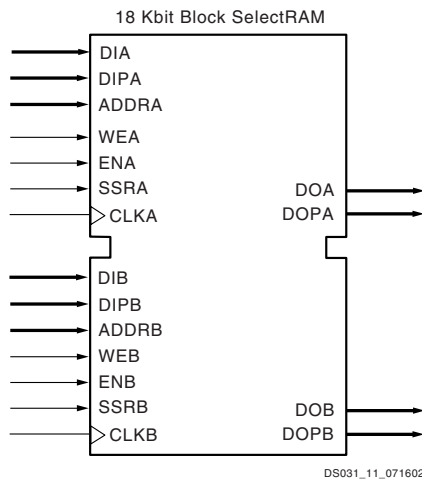

Figure 31: 18 Kbit Block SelectRAM in Dual-Port Mode

Port Aspect Ratios

Table 20 shows the depth and the width aspect ratios for the 18 Kbit block SelectRAM. Virtex-II block SelectRAM also includes dedicated routing resources to provide an efficient interface with CLBs, block SelectRAM, and multipliers.

Table 20: 18 Kbit Block SelectRAM Port Aspect Ratio

Width	Depth	Address Bus	Data Bus	Parity Bus
1	16,384	ADDR[13:0]	DATA[0]	N/A
2	8,192	ADDR[12:0]	DATA[1:0]	N/A
4	4,096	ADDR[11:0]	DATA[3:0]	N/A
9	2,048	ADDR[10:0]	DATA[7:0]	Parity[0]
18	1,024	ADDR[9:0]	DATA[15:0]	Parity[1:0]
36	512	ADDR[8:0]	DATA[31:0]	Parity[3:0]

Read/Write Operations

The Virtex-II block SelectRAM read operation is fully synchronous. An address is presented, and the read operation is enabled by control signals WEA and WEB in addition to ENA or ENB. Then, depending on clock polarity, a rising or falling clock edge causes the stored data to be loaded into output registers.

The write operation is also fully synchronous. Data and address are presented, and the write operation is enabled by control signals WEA or WEB in addition to ENA or ENB. Then, again depending on the clock input mode, a rising or falling clock edge causes the data to be loaded into the memory cell addressed.

A write operation performs a simultaneous read operation. Three different options are available, selected by configuration:

1. "WRITE_FIRST"

The "WRITE_FIRST" option is a transparent mode. The same clock edge that writes the data input (DI) into the memory also transfers DI into the output registers DO as shown in Figure 32.

2. "READ_FIRST"

The "READ_FIRST" option is a read-before-write mode. The same clock edge that writes data input (DI) into the

memory also transfers the prior content of the memory cell addressed into the data output registers DO, as shown in Figure 33.

3. "NO_CHANGE"

The "NO_CHANGE" option maintains the content of the output registers, regardless of the write operation. The clock edge during the write mode has no effect on the content of the data output register DO. When the port is configured as "NO_CHANGE", only a read operation loads a new value in the output register DO, as shown in Figure 34.

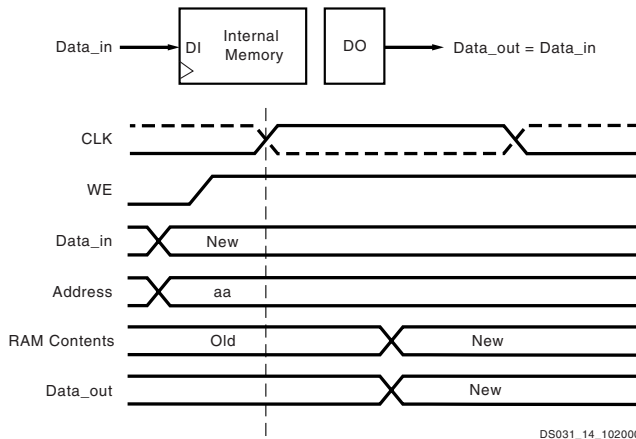

Figure 32: WRITE_FIRST Mode

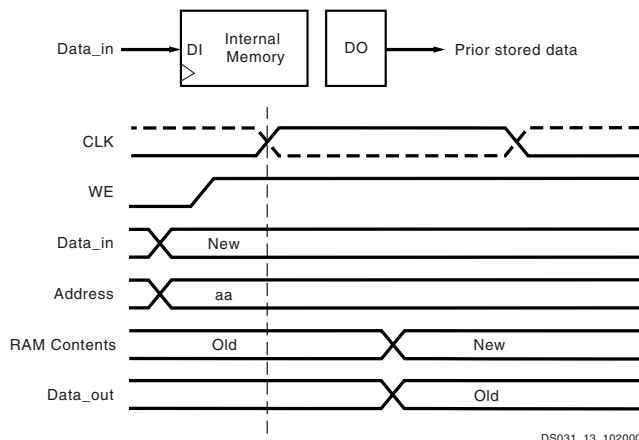

Figure 33: READ_FIRST Mode

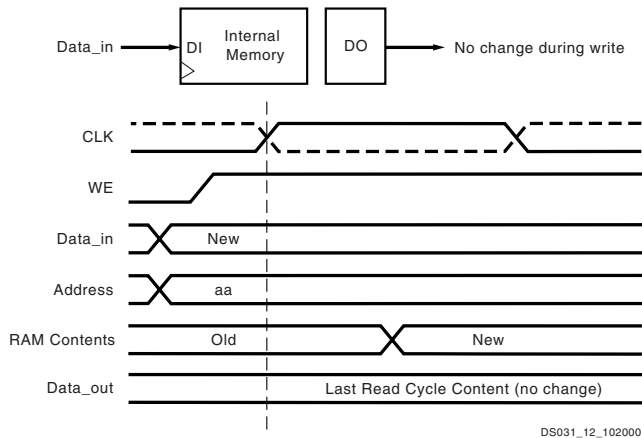

Figure 34: NO_CHANGE Mode

Control Pins and Attributes

Virtex-II SelectRAM memory has two independent ports with the control signals described in Table 21. All control inputs including the clock have an optional inversion.

Table 21: Control Functions

Control Signal	Function
CLK	Read and Write Clock
EN	Enable affects Read, Write, Set, Reset
WE	Write Enable
SSR	Set DO register to SRVAL (attribute)

Initial memory content is determined by the INIT_xx attributes. Separate attributes determine the output register value after device configuration (INIT) and SSR is asserted (SRVAL). Both attributes (INIT_B and SRVAL) are available

for each port when a block SelectRAM resource is configured as dual-port RAM.

Locations

Virtex-II SelectRAM memory blocks are located in either four or six columns. The number of blocks per column depends of the device array size and is equivalent to the number of CLBs in a column divided by four. Column locations are shown in Table 22.

Table 22: SelectRAM Memory Floor Plan

Device	Columns	SelectRAM Blocks	
		Per Column	Total
XQ2V1000	4	10	40
XQ2V3000	6	16	96
XQ2V6000	6	24	144

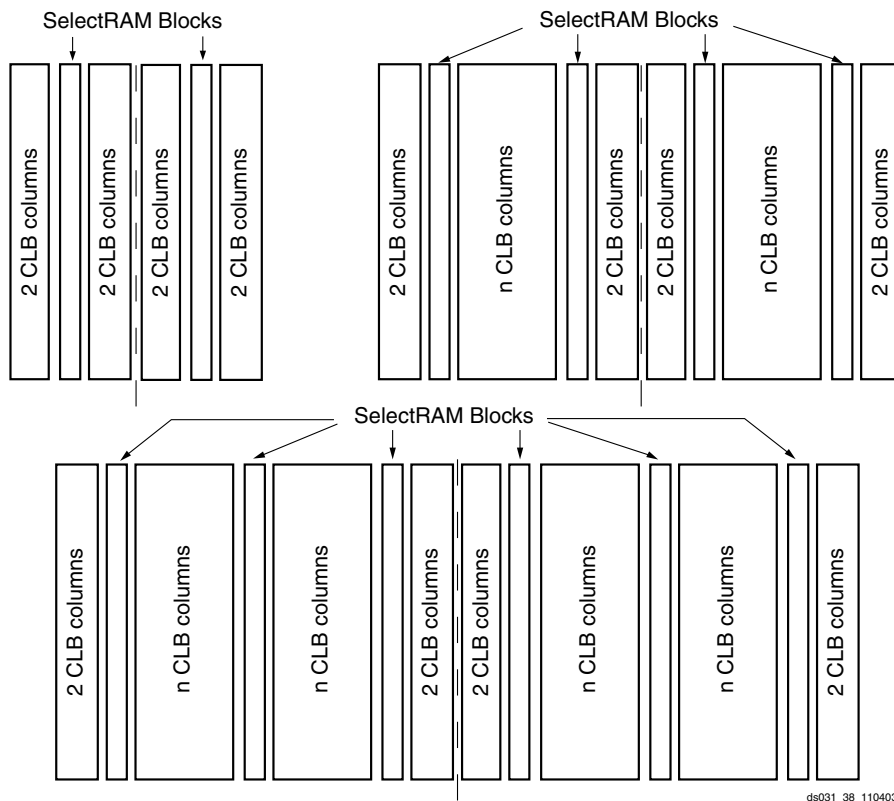

Figure 35: Block SelectRAM (2-column, 4-column, and 6-column)

ds031_38_110403

Total Amount of SelectRAM Memory

Table 23 shows the amount of block SelectRAM memory available for each Virtex-II device. The 18 Kbit SelectRAM blocks are cascadable to implement deeper or wider single- or dual-port memory resources.

Table 23: Virtex-II SelectRAM Memory Available

Device	Total SelectRAM Memory		
	Blocks	in Kbits	in Bits
XQ2V1000	40	720	737,280
XQ2V3000	96	1,728	1,769,472
XQ2V6000	144	2,592	2,654,208

18-Bit x 18-Bit Multipliers

Introduction

A Virtex-II multiplier block is an 18-bit by 18-bit 2's complement signed multiplier. Virtex-II devices incorporate many embedded multiplier blocks. These multipliers can be associated with an 18 Kbit block SelectRAM resource or can be used independently. They are optimized for high-speed operations and have a lower power consumption compared to an 18-bit x 18-bit multiplier in slices.

Each SelectRAM memory and multiplier block is tied to four switch matrices, as shown in Figure 36.

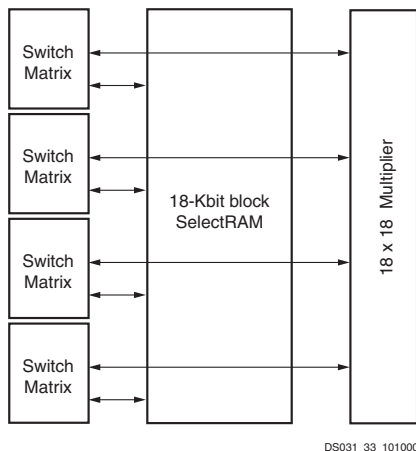

DS031_33_101000

Figure 36: SelectRAM and Multiplier Blocks

Association with Block SelectRAM Memory

The interconnect is designed to allow SelectRAM memory and multiplier blocks to be used at the same time, but some interconnect is shared between the SelectRAM and the multiplier. Thus, SelectRAM memory can be used only up to 18 bits wide when the multiplier is used, because the multiplier shares inputs with the upper data bits of the SelectRAM memory.

This sharing of the interconnect is optimized for an 18-bit-wide block SelectRAM resource feeding the multiplier. The use of SelectRAM memory and the multiplier with an accumulator in LUTs allows for implementation of a digital signal processor (DSP) multiplier-accumulator (MAC) function, which is commonly used in finite and infinite impulse response (FIR and IIR) digital filters.

Configuration

The multiplier block is an 18-bit by 18-bit signed multiplier (2's complement). Both A and B are 18-bit-wide inputs, and the output is 36 bits. Figure 37 shows a multiplier block.

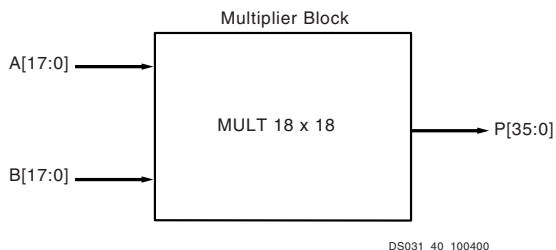

DS031_40_100400

Figure 37: Multiplier Block

Locations/Organization

Multiplier organization is identical to the 18 Kbit SelectRAM organization, because each multiplier is associated with an 18 Kbit block SelectRAM resource.

In addition to the built-in multiplier blocks, the CLB elements have dedicated logic to implement efficient multipliers in logic. (Refer to **Configurable Logic Blocks (CLBs)**).

Table 24: Multiplier Floor Plan

Device	Columns	Multipliers	
		Per Column	Total
XQ2V1000	4	10	40
XQ2V3000	6	16	96
XQ2V6000	6	24	144

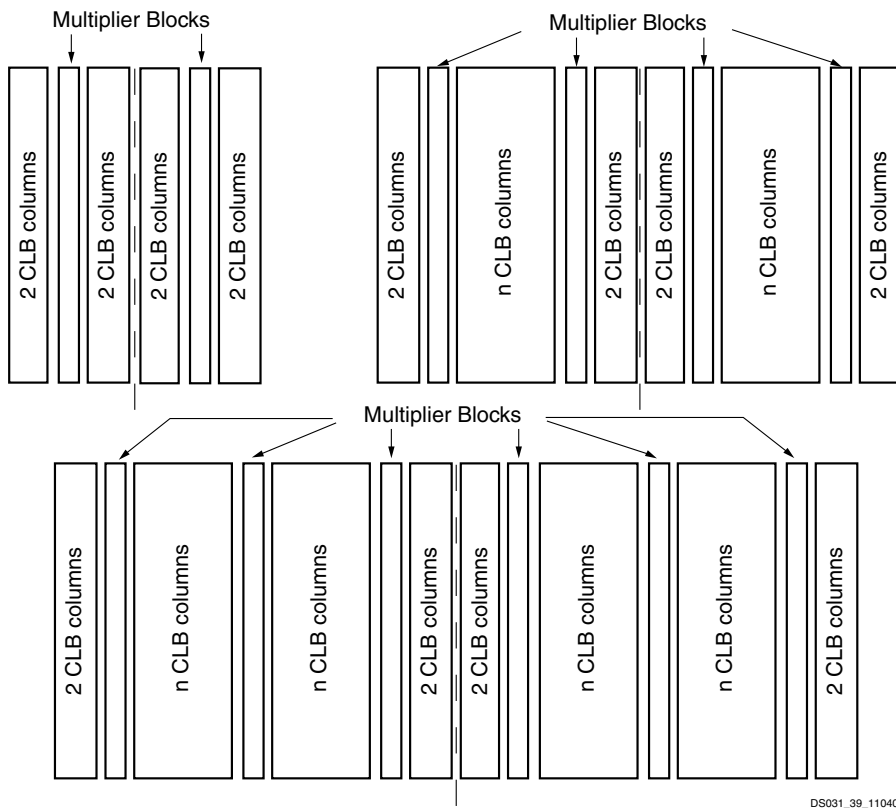

Figure 38: Multipliers (2-column, 4-column, and 6-column)

Global Clock Multiplexer Buffers

Virtex-II devices have 16 clock input pins that can also be used as regular user I/Os. Eight clock pads are on the top edge of the device, in the middle of the array, and eight are on the bottom edge, as illustrated in Figure 39.

The global clock multiplexer buffer represents the input to dedicated low-skew clock tree distribution in Virtex-II devices. Like the clock pads, eight global clock multiplexer buffers are on the top edge of the device and eight are on the bottom edge.

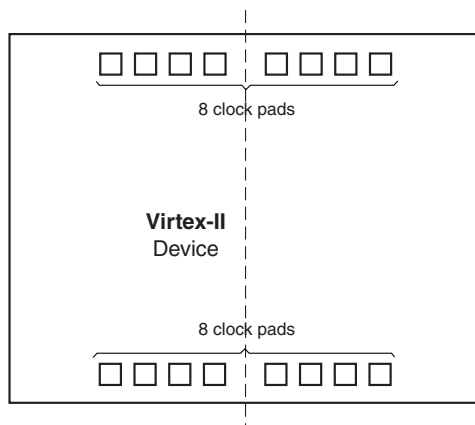

Figure 39: Virtex-II Clock Pads

Each global clock buffer can be driven by either the clock pad to distribute a clock directly to the device, or the Digital Clock Manager (DCM), discussed in **Digital Clock Manager (DCM)**, page 36. Each global clock buffer can also be driven by local interconnects. The DCM has clock output(s) that can be connected to global clock buffer inputs, as shown in **Figure 40**.

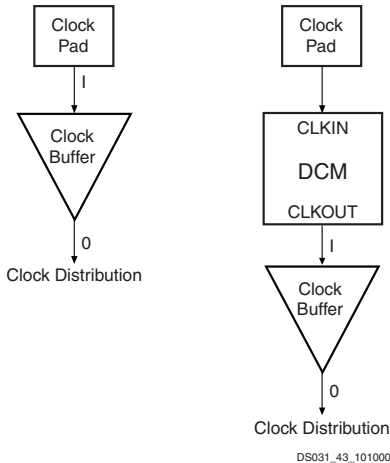

Figure 40: Virtex-II Clock Distribution Configurations

Global clock buffers are used to distribute the clock to some or all synchronous logic elements (such as registers in CLBs and IOBs, and SelectRAM blocks).

Eight global clocks can be used in each quadrant of the Virtex-II device. Designers should consider the clock distri-

bution detail of the device prior to pin-locking and floorplanning (see the *Virtex-II User Guide*, **UG002**).

Figure 42 shows clock distribution in Virtex-II devices.

In each quadrant, up to eight clocks are organized in clock rows. A clock row supports up to 16 CLB rows (eight up and eight down). For the largest devices a new clock row is added, as necessary.

To reduce power consumption, any unused clock branches remain static.

Global clocks are driven by dedicated clock buffers (BUFG), which can also be used to gate the clock (BUFGCE) or to multiplex between two independent clock inputs (BUFGMUX).

The most common configuration option of this element is as a buffer. A BUFG function in this (global buffer) mode, is shown in **Figure 41**.

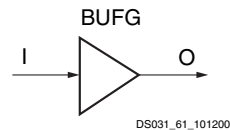

Figure 41: Virtex-II BUFG Function

The Virtex-II global clock buffer BUFG can also be configured as a clock enable/disable circuit (**Figure 43**), as well as a two-input clock multiplexer (**Figure 44**). A functional description of these two options is provided below. Each of them can be used in either of two modes, selected by configuration: rising clock edge or falling clock edge.

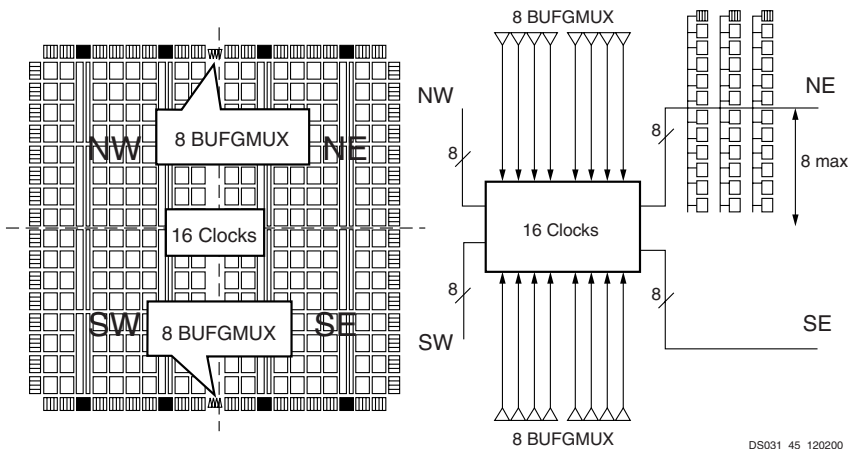

Figure 42: Virtex-II Clock Distribution

This section describes the rising clock edge option. For the opposite option, falling clock edge, just change all "rising" references to "falling" and all "High" references to "Low", except for the description of the CE or S levels. The rising clock edge option uses the BUFGCE and BUFGMUX primitives. The falling clock edge option uses the BUFGCE_1 and BUFGMUX_1 primitives.

BUFGCE

If the CE input is active (High) prior to the incoming rising clock edge, this Low-to-High-to-Low clock pulse passes through the clock buffer. Any level change of CE during the incoming clock High time has no effect.

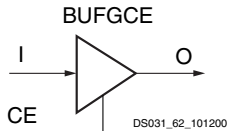

Figure 43: Virtex-II BUFGCE Function

If the CE input is inactive (Low) prior to the incoming rising clock edge, the following clock pulse does not pass through the clock buffer, and the output stays Low. Any level change of CE during the incoming clock High time has no effect. CE must not change during a short setup window just prior to the rising clock edge on the BUFGCE input I. Violating this setup time requirement can result in an undefined runt pulse output.

BUFGMUX

BUFGMUX can switch between two unrelated, even asynchronous clocks. Basically, a Low on S selects the I0 input, and a High on S selects the I1 input. Switching from one clock to the other is done in such a way that the output High and Low time is never shorter than the shortest High or Low time of either input clock. As long as the presently selected clock is High, any level change of S has no effect.

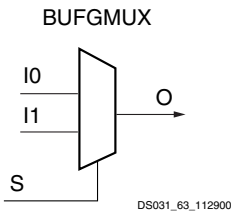

Figure 44: Virtex-II BUFGMUX Function

Local Clocking

In addition to global clocks, there are local clock resources in the Virtex-II devices. There are more than 72 local clocks in the Virtex-II family. These resources can be used for many different applications, including but not limited to

If the presently selected clock is Low while S changes, or if it goes Low after S has changed, the output is kept Low until the other ("to-be-selected") clock has made a transition from High to Low. At that instant, the new clock starts driving the output.

The two clock inputs can be asynchronous with regard to each other, and the S input can change at any time, except for a short setup time prior to the rising edge of the presently selected clock, that is, prior to the rising edge of the BUFGMUX output O. Violating this setup time requirement can result in an undefined runt pulse output.

All Virtex-II devices have 16 global clock multiplexer buffers.

Figure 45 shows a switchover from CLK0 to CLK1.

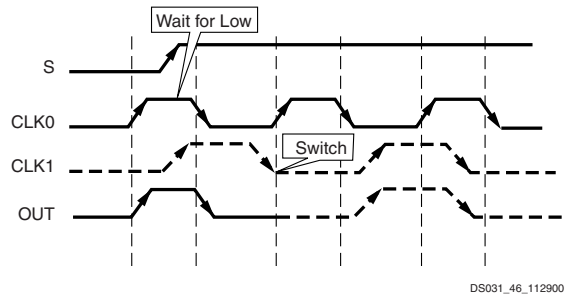

Figure 45: Clock Multiplexer Waveform Diagram

In Figure 45:

- The current clock is CLK0.
- S is activated High.
- If CLK0 is currently High, the multiplexer waits for CLK0 to go Low.
- Once CLK0 is Low, the multiplexer output stays Low until CLK1 transitions High to Low.
- When CLK1 transitions from High to Low, the output switches to CLK1.
- No glitches or short pulses can appear on the output.

memory interfaces. For example, even using only the left and right I/O banks, Virtex-II FPGAs can support up to 50 local clocks for DDR SDRAM. These interfaces can operate beyond 200 MHz on Virtex-II devices.

Digital Clock Manager (DCM)

The Virtex-II DCM offers a wide range of powerful clock management features:

- **Clock De-skew:** The DCM generates new system clocks (either internally or externally to the FPGA), which are phase-aligned to the input clock, thus eliminating clock distribution delays.
- **Frequency Synthesis:** The DCM generates a wide range of output clock frequencies, performing very flexible clock multiplication and division.
- **Phase Shifting:** The DCM provides both coarse phase shifting and fine-grained phase shifting with dynamic phase shift control.

The DCM utilizes fully digital delay lines allowing robust high-precision control of clock phase and frequency. It also utilizes fully digital feedback systems, operating dynamically to compensate for temperature and voltage variations during operation.

Up to four of the nine DCM clock outputs can drive inputs to global clock buffers or global clock multiplexer buffers simultaneously (see [Figure 46](#)). All DCM clock outputs can simultaneously drive general routing resources, including routes to output buffers.

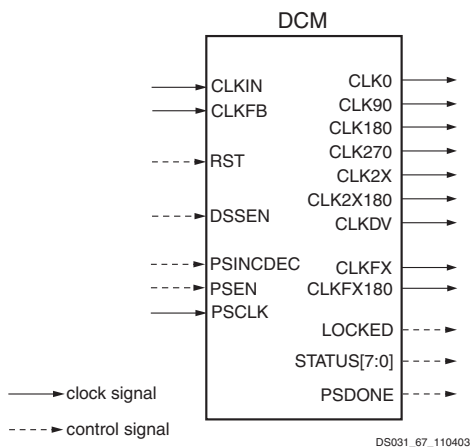

Figure 46: Digital Clock Manager

The DCM can be configured to delay the completion of the Virtex-II configuration process until after the DCM has achieved lock. This guarantees that the chip does not begin operating until after the system clocks generated by the DCM have stabilized.

The DCM has the following general control signals:

- RST input pin: resets the entire DCM.
- LOCKED output pin: asserted High when all enabled DCM circuits have locked.
- STATUS output pins (active High): shown in [Table 25](#).

Table 25: DCM Status Pins

Status Pin	Function
0	Phase Shift Overflow
1	CLKIN Stopped
2	CLKFX Stopped
3	N/A
4	N/A
5	N/A
6	N/A
7	N/A

Clock De-Skew

The DCM de-skews the output clocks relative to the input clock by automatically adjusting a digital delay line. Additional delay is introduced so that clock edges arrive at internal registers and block RAMs simultaneously with the clock edges arriving at the input clock pad. Alternatively, external clocks, which are also de-skewed relative to the input clock, can be generated for board-level routing. All DCM output clocks are phase-aligned to CLK0 and, therefore, are also phase-aligned to the input clock.

To achieve clock de-skew, the CLKFB input must be connected, and its source must be either CLK0 or CLK2X. CLKFB must always be connected, unless only the CLKFX or CLKFX180 outputs are used and de-skew is not required.

Frequency Synthesis

The DCM provides flexible methods for generating new clock frequencies. Each method has a different operating frequency range and different AC characteristics. The CLK2X and CLK2X180 outputs double the clock frequency. The CLKDV output creates divided output clocks with division options of 1.5, 2, 2.5, 3, 3.5, 4, 4.5, 5, 5.5, 6, 6.5, 7, 7.5, 8, 9, 10, 11, 12, 13, 14, 15, and 16.

The CLKFX and CLKFX180 outputs can be used to produce clocks at the following frequency:

$$\text{FREQ}_{\text{CLKFX}} = (M/D) * \text{FREQ}_{\text{CLKIN}}$$

where M and D are two integers. Specifications for M and D are provided under **DCM Timing Parameters**. By default, M=4 and D=1, which results in a clock output frequency four times faster than the clock input frequency (CLKIN).

CLK2X180 is phase shifted 180 degrees relative to CLK2X. CLKFX180 is phase shifted 180 degrees relative to CLKFX. All frequency synthesis outputs automatically have 50/50 duty cycles (with the exception of the CLKDV output when performing a non-integer divide in high-frequency mode).

Note that CLK2X and CLK2X180 are not available in high-frequency mode.

Phase Shifting

The DCM provides additional control over clock skew through either coarse- or fine-grained phase shifting. The CLK0, CLK90, CLK180, and CLK270 outputs are each phase shifted by ¼ of the input clock period relative to each other, providing coarse phase control. Note that CLK90 and CLK270 are not available in high-frequency mode.

Fine-phase adjustment affects all nine DCM output clocks. When activated, the phase shift between the rising edges of CLKIN and CLKFB is a specified fraction of the input clock period.

In variable mode, the PHASE_SHIFT value can also be dynamically incremented or decremented as determined by PSINCDEC synchronously to PSCLK, when the PSEN input is active. Figure 47 illustrates the effects of fine-phase

shifting. For more information on DCM features, see the *Virtex-II User Guide* (UG002).

Table 26 lists fine-phase shifting control pins, when used in variable mode.

Table 26: Fine-Phase Shifting Control Pins

Control Pin	Direction	Function
PSINCDEC	in	Increment or decrement
PSEN	in	Enable ± phase shift
PSCLK	in	Clock for phase shift
PSDONE	out	Active when completed

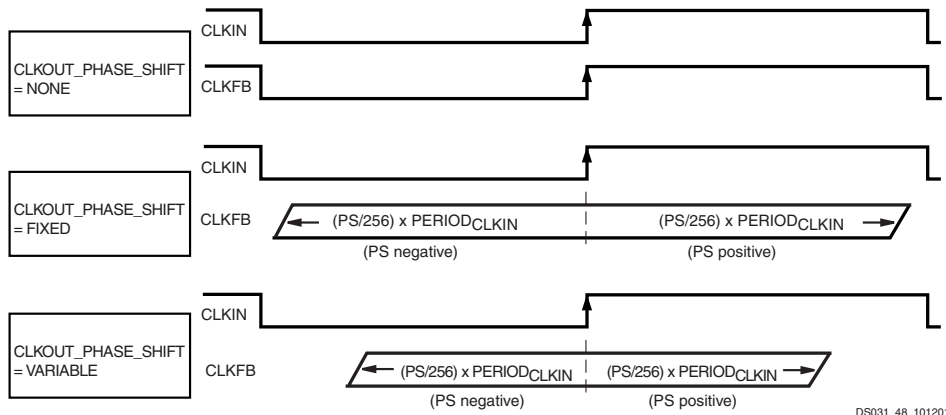

Figure 47: Fine-Phase Shifting Effects

Two separate components of the phase shift range must be understood:

- PHASE_SHIFT attribute range
- FINE_SHIFT_RANGE DCM timing parameter range

The PHASE_SHIFT attribute is the numerator in the following equation:

$$\text{Phase Shift (ns)} = (\text{PHASE_SHIFT}/256) * \text{PERIOD}_{\text{CLKIN}}$$

The full range of this attribute is always -255 to +255, but its practical range varies with CLKIN frequency, as constrained by the FINE_SHIFT_RANGE component, which represents the total delay achievable by the phase shift delay line. Total delay is a function of the number of delay taps used in the circuit. Across process, voltage, and temperature, this absolute range is guaranteed to be as specified under **DCM Timing Parameters**.

Absolute range (fixed mode) = ± FINE_SHIFT_RANGE

Absolute range (variable mode) = ± FINE_SHIFT_RANGE/2

The reason for the difference between fixed and variable modes is as follows. For variable mode to allow symmetric, dynamic sweeps from -255/256 to +255/256, the DCM sets the "zero phase skew" point as the middle of the delay line, thus dividing the total delay line range in half. In fixed mode, since the PHASE_SHIFT value never changes after configuration, the entire delay line is available for insertion into either the CLKIN or CLKFB path (to create either positive or negative skew).

Taking both of these components into consideration, the following are some usage examples:

- If $\text{PERIOD}_{\text{CLKIN}} = 2 * \text{FINE_SHIFT_RANGE}$, then PHASE_SHIFT in fixed mode is limited to ± 128, and in variable mode it is limited to ± 64.
- If $\text{PERIOD}_{\text{CLKIN}} = \text{FINE_SHIFT_RANGE}$, then PHASE_SHIFT in fixed mode is limited to ± 255, and in variable mode it is limited to ± 128.
- If $\text{PERIOD}_{\text{CLKIN}} \leq 0.5 * \text{FINE_SHIFT_RANGE}$, then PHASE_SHIFT is limited to ± 255 in either mode.

Operating Modes

The frequency ranges of DCM input and output clocks depend on the operating mode specified, either low-frequency mode or high-frequency mode, according to [Table 27](#). (For actual values, see [QPro Virtex-II Switching](#)

Characteristics.) The CLK2X, CLK2X180, CLK90, and CLK270 outputs are not available in high-frequency mode. High or low-frequency mode is selected by an attribute.

Table 27: DCM Frequency Ranges

Output Clock	Low-Frequency Mode		High-Frequency Mode	
	CLKIN Input	CLK Output	CLKIN Input	CLK Output
CLK0, CLK180	CLKIN_FREQ_DLL_LF	CLKOUT_FREQ_1X_LF	CLKIN_FREQ_DLL_HF	CLKOUT_FREQ_1X_HF
CLK90, CLK270	CLKIN_FREQ_DLL_LF	CLKOUT_FREQ_1X_LF	NA	NA
CLK2X, CLK2X180	CLKIN_FREQ_DLL_LF	CLKOUT_FREQ_2X_LF	NA	NA
CLKDV	CLKIN_FREQ_DLL_LF	CLKOUT_FREQ_DV_LF	CLKIN_FREQ_DLL_HF	CLKOUT_FREQ_DV_HF
CLKFX, CLKFX180	CLKIN_FREQ_FX_LF	CLKOUT_FREQ_FX_LF	CLKIN_FREQ_FX_HF	CLKOUT_FREQ_FX_HF

Locations/Organization

Virtex-II DCMs are placed on the top and the bottom of each block RAM and multiplier column. The number of DCMs depends on the device size, as shown in [Table 28](#).

Table 28: DCM Organization

Device	Columns	DCMs
XQ2V1000	4	8
XQ2V3000	6	12
XQ2V6000	6	12

Active Interconnect Technology

Local and global Virtex-II routing resources are optimized for speed and timing predictability, as well as to facilitate IP cores implementation. Virtex-II Active Interconnect Technology is a fully buffered programmable routing matrix. All routing resources are segmented to offer the advantages of a hierarchical solution. Virtex-II logic features like CLBs, IOBs, block RAM, multipliers, and DCMs are all connected

to an identical switch matrix for access to global routing resources, as shown in Figure 48.

Each Virtex-II device can be represented as an array of switch matrices with logic blocks attached, as illustrated in Figure 49.

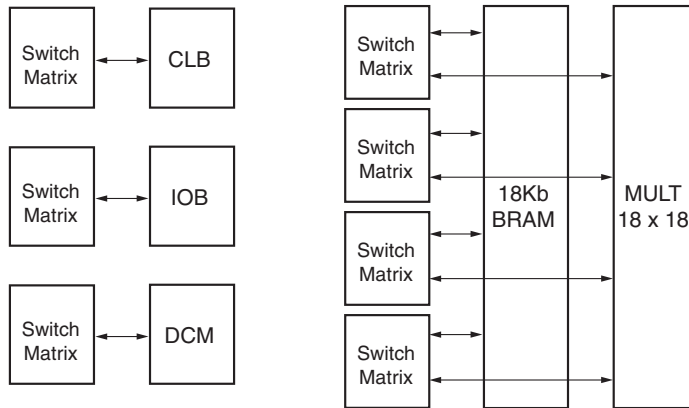

DS031_55_101000

Figure 48: Active Interconnect Technology

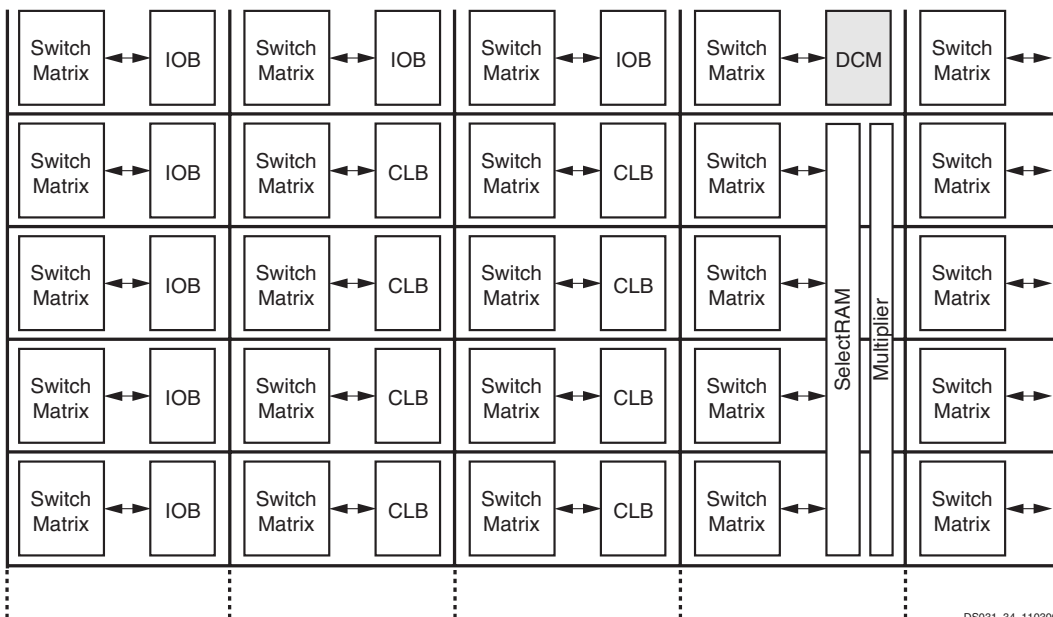

DS031_34_110300

Figure 49: Routing Resources

Place-and-route software takes advantage of this regular array to deliver optimum system performance and fast compile times. The segmented routing resources are essential to guarantee IP cores portability and to efficiently handle an

incremental design flow that is based on modular implementations. Total design time is reduced due to fewer and shorter design iterations.

Hierarchical Routing Resources

Most Virtex-II signals are routed using the global routing resources, which are located in horizontal and vertical routing channels between each switch matrix.

As shown in [Figure 50](#), Virtex-II devices have fully buffered programmable interconnections, with a number of

resources counted between any two adjacent switch matrix rows or columns. Fanout has minimal impact on the performance of each net.

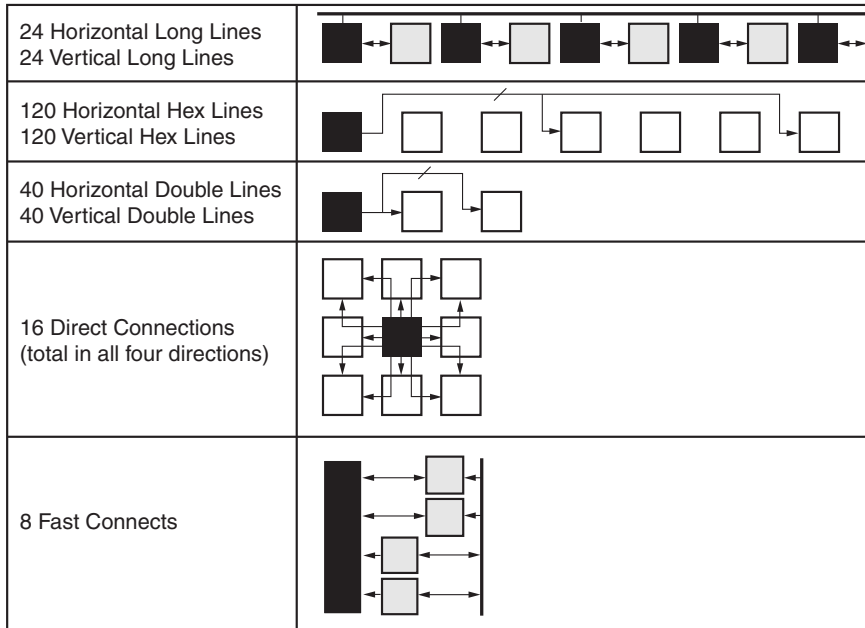

DS031_60_110403

Figure 50: Hierarchical Routing Resources

In [Figure 50](#):

- Long lines are bidirectional wires that distribute signals across the device. Vertical and horizontal long lines span the full height and width of the device.
- Hex lines route signals to every third or sixth block away in all four directions. Organized in a staggered pattern, hex lines can only be driven from one end. Hex-line signals can be accessed either at the endpoints or at the midpoint (three blocks from the source).
- Double lines route signals to every first or second block away in all four directions. Organized in a staggered pattern, double lines can be driven only at their endpoints. Double-line signals can be accessed either at the endpoints or at the midpoint (one block from the source).
- Direct connect lines route signals to neighboring blocks: vertically, horizontally, and diagonally.
- Fast connect lines are the internal CLB local interconnections from LUT outputs to LUT inputs.

Dedicated Routing

In addition to the global and local routing resources, dedicated signals are available:

- There are eight global clock nets per quadrant (see [Global Clock Multiplexer Buffers](#)).
- Horizontal routing resources are provided for on-chip 3-state buses. Four partitionable bus lines are provided per CLB row, permitting multiple buses within a row. (See [3-State Buffers](#).)
- Two dedicated carry-chain resources per slice column (two per CLB column) propagate carry-chain MUXCY

output signals vertically to the adjacent slice. (See **CLB/Slice Configurations**.)

- One dedicated SOP chain per slice row (two per CLB row) propagates ORCY output logic signals horizontally to the adjacent slice. (See **Sum of Products**.)
- One dedicated shift chain per CLB connects the output of LUTs in shift-register mode to the input of the next LUT in shift-register mode (vertically) inside the CLB. (See **Shift Registers**, page 22.)

Creating a Design

Creating Virtex-II designs is easy with Xilinx Integrated Synthesis Environment (ISE) development systems, which support advanced design capabilities, including ProActive Timing Closure, integrated logic analysis, and the fastest place and route runtimes in the industry. ISE solutions enable designers to get the performance they need, quickly and easily.

As a result of the ongoing cooperative development efforts between Xilinx and EDA Alliance partners, designers can take advantage of the benefits provided by EDA technologies in the programmable logic design process. Xilinx development systems are available in a number of easy to use configurations, collectively known as the ISE Series.

ISE Alliance

The ISE Alliance solution is designed to plug and play within an existing design environment. Built using industry standard data formats and netlists, these stable, flexible products enable Alliance EDA partners to deliver their best design automation capabilities to Xilinx customers, along with the time to market benefits of ProActive Timing Closure.

ISE Foundation

The ISE Foundation solution delivers the benefits of true HDL-based design in a seamlessly integrated design environment. An intuitive project navigator, as well as powerful HDL design and two HDL synthesis tools, ensure that high-quality results are achieved quickly and easily. The ISE Foundation product includes:

- State Diagram entry using Xilinx StateCAD
- Automatic HDL Testbench generation using Xilinx HDLBench
- HDL Simulation using ModelSim XE

Design Flow

Virtex-II design flow proceeds as follows:

- Design Entry
- Synthesis
- Implementation
- Verification

Most programmable logic designers iterate through these steps several times in the process of completing a design.

Design Entry

All Xilinx ISE development systems support the mainstream EDA design entry capabilities, ranging from schematic design to advanced HDL design methodologies. Given the high densities of the Virtex-II family, designs are created most efficiently using HDLs. To further improve their time to market, many Xilinx customers employ incremental, modular, and Intellectual Property (IP) design techniques. When properly used, these techniques further accelerate the logic design process.

To enable designers to leverage existing investments in EDA tools and to ensure high-performance design flows, Xilinx jointly develops tools with leading EDA vendors, including:

- Aldec
- Cadence
- Exemplar
- Mentor Graphics
- Model Technology
- Synopsys
- Synplicity

Complete information on Alliance Series partners and their associated design flows is available at <http://www.xilinx.com> on the Xilinx Alliance Series web page.

The ISE Foundation product offers schematic entry and HDL design capabilities as part of an integrated design solution, enabling one-stop shopping. These capabilities are powerful, easy to use, and they support the full portfolio of Xilinx programmable logic devices. HDL design capabilities include a color-coded HDL editor with integrated language templates, state diagram entry, and Core generation capabilities.

Synthesis

The ISE Alliance product is engineered to support advanced design flows with the industry's best synthesis tools. Advanced design methodologies include:

- Physical Synthesis
- Incremental synthesis
- RTL floorplanning
- Direct physical mapping

The ISE Foundation product seamlessly integrates synthesis capabilities purchased directly from Exemplar, Synopsys, and Synplicity. In addition, it includes the capabilities of Xilinx Synthesis Technology.

A benefit of having two seamlessly integrated synthesis engines within an ISE design flow is the ability to apply alternative sets of optimization techniques on designs, helping to ensure that designers can meet even the toughest timing requirements.

Design Implementation

The ISE Series development systems include Xilinx timing-driven implementation tools, frequently called “place and route” or “fitting” software. This robust suite of tools enables the creation of an intuitive, flexible, tightly integrated design flow that efficiently bridges “logical” and “physical” design domains. This simplifies the task of defining a design, including its behavior, timing requirements, and optional layout (or floorplanning), as well as simplifying the task of analyzing reports generated during the implementation process.

The Virtex-II implementation process is comprised of Synthesis, translation, mapping, place and route, and configuration file generation. While the tools can be run individually, many designers choose to run the entire implementation process with the click of a button. To assist those who prefer to script their design flows, Xilinx provides Xflow, an automated single command line process.

Design Verification

In addition to conventional design verification using static timing analysis or simulation techniques, Xilinx offers powerful in-circuit debugging techniques using ChipScope ILA (Integrated Logic Analysis). The reconfigurable nature of Xilinx FPGAs means that designs can be verified in real time without the need for extensive sets of software simulation vectors.

For simulation, the system extracts post-layout timing information from the design database, and back-annotates this information into the netlist for use by the simulator. The back annotation features a variety of patented Xilinx techniques, resulting in the industry’s most powerful simulation flows. Alternatively, timing-critical portions of a design can be verified using the Xilinx static timing analyzer or a third party static timing analysis tool like Synopsys Prime Time, by exporting timing data in the STAMP data format.

For in-circuit debugging, ChipScope ILA enables designers to analyze the real-time behavior of a device while operating at full system speeds. Logic analysis commands and captured data are transferred between the ChipScope software and ILA cores within the Virtex-II FPGA, using industry standard JTAG protocols. These JTAG transactions are driven over an optional download cable (MultiLINX or JTAG), connecting the Virtex device in the target system to a PC or workstation.

ChipScope ILA was designed to look and feel like a logic analyzer, making it easy to begin debugging a design immediately. Modifications to the desired logic analysis can be downloaded directly into the system in a matter of minutes.

Other Unique Features of Virtex-II Design Flow

Xilinx design flows feature a number of unique capabilities. Among these are efficient incremental HDL design flows,

which are robust capabilities enabled by Xilinx exclusive hierarchical floorplanning capabilities. Another powerful design capability only available in the Xilinx design flow is “Modular Design”, part of the Xilinx suite of team design tools, which enables autonomous design, implementation, and verification of design modules.

Incremental Synthesis

Xilinx unique hierarchical floorplanning capabilities enable designers to create a programmable logic design by isolating design changes within one hierarchical “logic block”, and perform synthesis, verification, and implementation processes on that specific logic block. By preserving the logic in unchanged portions of a design, Xilinx incremental design makes the high-density design process more efficient.

Xilinx hierarchical floorplanning capabilities can be specified using the high-level floorplanner or a preferred RTL floorplanner (see the Xilinx website for a list of supported EDA partners). When used in conjunction with one of the EDA partners’ floorplanners, higher performance results can be achieved, as many synthesis tools use this more predictable detailed physical implementation information to establish more aggressive and accurate timing estimates when performing their logic optimizations.

Modular Design

Xilinx innovative modular design capabilities take the incremental design process one step further by enabling the designer to delegate responsibility for completing the design, synthesis, verification, and implementation of a hierarchical “logic block” to an arbitrary number of designers - assigning a specific region within the target FPGA for exclusive use by each of the team members.

This team design capability enables an autonomous approach to design modules, changing the hand-off point to the lead designer or integrator from “my module works in simulation” to “my module works in the FPGA”. This unique design methodology also leverages the Xilinx hierarchical floorplanning capabilities and enables the Xilinx (or EDA partner) floorplanner to manage the efficient implementation of very high-density FPGAs.

Configuration

Virtex-II devices are configured by loading application-specific configuration data into the internal configuration memory. Configuration is carried out using a subset of the device pins, some of which are dedicated, while others can be re-used as general purpose inputs and outputs once configuration is complete.

Depending on the system design, several configuration modes are supported, selectable via mode pins. The mode pins M2, M1, and M0 are dedicated pins. An additional pin, HSWAP_EN, is used in conjunction with the mode pins to select whether user I/O pins have pull-ups during configura-

tion. By default, HSWAP_EN is tied High (internal pull-up), which shuts off the pull-ups on the user I/O pins during configuration. When HSWAP_EN is tied Low, user I/Os have pull-ups during configuration. Other dedicated pins are CCLK (the configuration clock pin), DONE, PROG_B, and the boundary-scan pins: TDI, TDO, TMS, and TCK. Depending on the configuration mode chosen, CCLK can be an output generated by the FPGA, or an input accepting an externally generated clock. The configuration pins and boundary-scan pins are independent of the V_{CCO} . The auxiliary power supply (V_{CCAUX}) of 3.3V is used for these pins. All configuration pins are LVTTTL 12 mA. (See **QPro Virtex-II DC Characteristics**.)

A persist option is available which can be used to force the configuration pins to retain their configuration function even after device configuration is complete. If the persist option is not selected, then the configuration pins with the exception of CCLK, PROG_B, and DONE can be used as user I/O in normal operation. The persist option does not apply to the boundary-scan related pins. The persist feature is valuable in applications which employ partial reconfiguration or reconfiguration on the fly.

Configuration Modes

Virtex-II supports the following five configuration modes:

- Slave-serial mode
- Master-serial mode
- Slave SelectMAP mode
- Master SelectMAP mode
- Boundary-Scan mode (IEEE 1532/IEEE 1149)

A detailed description of configuration modes is provided in the *Virtex-II User Guide* ([UG002](#)).

Slave-Serial Mode

In slave-serial mode, the FPGA receives configuration data in bit-serial form from a serial PROM or other serial source of configuration data. The CCLK pin on the FPGA is an input in this mode. The serial bitstream must be setup at the DIN input pin a short time before each rising edge of the externally generated CCLK.

Multiple FPGAs can be daisy chained for configuration from a single source. After a particular FPGA has been configured, the data for the next device is routed internally to the DOUT pin. The data on the DOUT pin changes on the rising edge of CCLK.

Slave-serial mode is selected by applying <111> to the mode pins (M2, M1, M0). A weak pull-up on the mode pins makes slave serial the default mode if the pins are left unconnected.

Master-Serial Mode

In master-serial mode, the CCLK pin is an output pin. It is the Virtex-II FPGA device that drives the configuration clock on the CCLK pin to a Xilinx Serial PROM, which in turn

feeds bit-serial data to the DIN input. The FPGA accepts this data on each rising CCLK edge. After the FPGA has been loaded, the data for the next device in a daisy chain is presented on the DOUT pin after the rising CCLK edge.

The interface is identical to slave serial except that an internal oscillator is used to generate the configuration clock (CCLK). A wide range of frequencies can be selected for CCLK, which always starts at a slow default frequency. Configuration bits then switch CCLK to a higher frequency for the remainder of the configuration.

Slave SelectMAP Mode

The SelectMAP mode is the fastest configuration option. Byte-wide data is written into the Virtex-II FPGA device with a BUSY flag controlling the flow of data. An external data source provides a byte stream, CCLK, an active-Low Chip Select (CS_B) signal, and a Write signal (RDWR_B). If BUSY is asserted (High) by the FPGA, the data must be held until BUSY goes Low. Data can also be read using the SelectMAP mode. If RDWR_B is asserted, configuration data is read out of the FPGA as part of a readback operation.

After configuration, the pins of the SelectMAP port can be used as additional user I/O. Alternatively, the port can be retained to permit high-speed 8-bit readback using the persist option.

Multiple Virtex-II FPGAs can be configured using the SelectMAP mode, and can be made to start-up simultaneously. To configure multiple devices in this way, wire the individual CCLK, Data, RDWR_B, and BUSY pins of all the devices in parallel. The individual devices are loaded separately by deasserting the CS_B pin of each device in turn and writing the appropriate data.

Master SelectMAP Mode

This mode is a master version of the SelectMAP mode. The device is configured byte-wide on a CCLK supplied by the Virtex-II FPGA. Timing is similar to the Slave SerialMAP mode except that CCLK is supplied by the Virtex-II FPGA.

Boundary-Scan (JTAG, IEEE 1532) Mode

In boundary-scan mode, dedicated pins are used for configuring the Virtex-II device. The configuration is done entirely through the IEEE 1149.1 Test Access Port (TAP). Virtex-II device configuration using boundary scan is compliant with IEEE 1149.1-1993 standard and the new IEEE 1532 standard for In-System Configurable (ISC) devices. The IEEE 1532 standard is backward compliant with the IEEE 1149.1-1993 TAP and state machine. The IEEE Standard 1532 for In-System Configurable (ISC) devices is intended to be programmed, reprogrammed, or tested on the board via a physical and logical protocol.

Configuration through the boundary-scan port is always available, independent of the mode selection. Selecting the boundary-scan mode simply turns off the other modes.

Table 29: Virtex-II Configuration Mode Pin Settings

Configuration Mode ⁽¹⁾	M2	M1	M0	CCLK Direction	Data Width	Serial D _{OUT} ⁽²⁾
Master Serial	0	0	0	Out	1	Yes
Slave Serial	1	1	1	In	1	Yes
Master SelectMAP	0	1	1	Out	8	No
Slave SelectMAP	1	1	0	In	8	No
Boundary Scan	1	0	1	N/A	1	No

Notes:

1. The HSWAP_EN pin controls the pullups. Setting M2, M1, and M0 selects the configuration mode, while the HSWAP_EN pin controls whether or not the pullups are used.
2. Daisy chaining is possible only in modes where Serial D_{OUT} is used. For example, in SelectMAP modes, the first device does NOT support daisy chaining of downstream devices.

Table 30 lists the total number of bits required to configure each device.

Table 30: Virtex-II Bitstream Lengths

Device	# of Configuration Bits
XQ2V1000	3,753,432
XQ2V3000	9,595,304
XQ2V6000	19,760,560

Notes:

1. These values are only valid for STEPPING LEVEL 1.
2. Only STEPPING LEVEL 1 should be used with QPro devices.

Configuration Sequence

The configuration of Virtex-II devices is a three-phase process after Power On Reset or POR. POR occurs when V_{CCINT} is greater than 1.2V, V_{CCAUX} is greater than 2.5V, and V_{CCO} (bank 4) is greater than 1.5V. Once the POR voltages have been reached, the three-phase process begins.

First, the configuration memory is cleared. Next, configuration data is loaded into the memory, and finally, the logic is activated by a start-up process.

Configuration is automatically initiated on power-up unless it is delayed by the user. The INIT_B pin can be held Low using an open-drain driver. An open-drain is required since INIT_B is a bidirectional open-drain pin that is held Low by a Virtex-II FPGA device while the configuration memory is being cleared. Extending the time that the pin is Low causes the configuration sequencer to wait. Thus, configuration is delayed by preventing entry into the phase where data is loaded.

The configuration process can also be initiated by asserting the PROG_B pin. The end of the memory-clearing phase is signaled by the INIT_B pin going High, and the completion of the entire process is signaled by the DONE pin going High. The Global Set/Reset (GSR) signal is pulsed after the last frame of configuration data is written but before the

start-up sequence. The GSR signal resets all flip-flops on the device.

The default start-up sequence is that one CCLK cycle after DONE goes High, the global 3-state signal (GTS) is released. This permits device outputs to turn on as necessary. One CCLK cycle later, the Global Write Enable (GWE) signal is released. This permits the internal storage elements to begin changing state in response to the logic and the user clock.

The relative timing of these events can be changed via configuration options in software. In addition, the GTS and GWE events can be made dependent on the DONE pins of multiple devices all going High, forcing the devices to start synchronously. The sequence can also be paused at any stage, until lock has been achieved on any or all DCMs, as well as the DCI.

Readback

In this mode, configuration data from the Virtex-II FPGA device can be read back. Readback is supported only in the SelectMAP (master and slave) and Boundary Scan modes.

Along with the configuration data, it is possible to read back the contents of all registers, distributed SelectRAM, and block RAM resources. This capability is used for real-time debugging. For more detailed configuration information, see the *Virtex-II User Guide* ([UG002](#)).

Bitstream Encryption

Virtex-II devices have an on-chip decryptor using one or two sets of three keys for triple-key Data Encryption Standard (DES) operation. Xilinx software tools offer an optional encryption of the configuration data (bitstream) with a triple-key DES determined by the designer.

The keys are stored in the FPGA by JTAG instruction and retained by a battery connected to the V_{BATT} pin, when the device is not powered. Virtex-II devices can be configured with the corresponding encrypted bitstream, using any of the configuration modes described previously.

A detailed description of how to use bitstream encryption is provided in the *Virtex-II User Guide*. Your local FAE can also provide specific information on this feature.

Partial Reconfiguration

Partial reconfiguration of Virtex-II devices can be accomplished in either Slave SelectMAP mode or Boundary-Scan mode. Instead of resetting the chip and doing a full configuration, new data is loaded into a specified area of the chip,

while the rest of the chip remains in operation. Data is loaded on a column basis, with the smallest load unit being a configuration “frame” of the bitstream (device size dependent).

Partial reconfiguration is useful for applications that require different designs to be loaded into the same area of a chip, or that require the ability to change portions of a design without having to reset or reconfigure the entire chip.

QPro Virtex-II Electrical Characteristics

QPro Virtex-II devices are only available with the –4 speed grade. QPro Virtex-II DC and AC characteristics are specified for military grade. Except for the operating temperature range, or unless otherwise noted, all the DC and AC electrical parameters are the same for a particular speed grade (that is, the timing characteristics of a –4 speed grade military device are the same as for a –4 speed grade commer-

cial device). All supply voltage and junction temperature specifications are representative of worst-case conditions. The parameters included are common to popular designs and typical applications. Contact Xilinx for design considerations requiring more detailed information.

All specifications are subject to change without notice.

QPro Virtex-II DC Characteristics

Table 31: Absolute Maximum Ratings

Symbol	Description ⁽¹⁾		Units
V _{CCINT}	Internal supply voltage relative to GND	–0.5 to 1.65	V
V _{CCAUX}	Auxiliary supply voltage relative to GND	–0.5 to 4.0	V
V _{CCO}	Output drivers supply voltage relative to GND	–0.5 to 4.0	V
V _{BATT}	Key memory battery backup supply	–0.5 to 4.0	V
V _{REF}	Input reference voltage	–0.5 to V _{CCO} + 0.5	V
V _{IN} ⁽³⁾	Input voltage relative to GND (user and dedicated I/Os)	–0.5 to V _{CCO} + 0.5	V
V _{TS}	Voltage applied to 3-state output (user and dedicated I/Os)	–0.5 to 4.0	V
T _{STG}	Storage temperature (ambient)	–65 to +150	°C
T _{SOL}	Maximum soldering temperature	+220	°C
T _J	Operating junction temperature ⁽²⁾	+125	°C

Notes:

1. Stresses beyond those listed under Absolute Maximum Ratings might cause permanent damage to the device. These are stress ratings only, and functional operation of the device at these or any other conditions beyond those listed under Operating Conditions is not implied. Exposure to Absolute Maximum Ratings conditions for extended periods of time might affect device reliability.
2. For soldering guidelines and thermal considerations, see the [Device Packaging](#) information on the Xilinx website.
3. Inputs configured as PCI are fully PCI compliant. This statement takes precedence over any specification that would imply that the device is not PCI compliant.

Table 32: Recommended Operating Conditions

Symbol	Description	Package	Min	Max	Units
V _{CCINT}	Internal supply voltage relative to GND, T _C = -55° C to +125° C	Ceramic	1.425	1.575	V
	Internal supply voltage relative to GND, T _J = -55° C to +125° C	Plastic	1.425	1.575	V
V _{CCAUX}	Auxiliary supply voltage relative to GND, T _C = -55° C to +125° C	Ceramic	3.135	3.465	V
	Auxiliary supply voltage relative to GND, T _J = -55° C to +125° C	Plastic	3.135	3.465	V
V _{CCO}	Supply voltage relative to GND, T _C = -55° C to +125° C	Ceramic	1.2	3.6	V
	Supply voltage relative to GND, T _J = -55° C to +125° C	Plastic	1.2	3.6	V
V _{BATT}	Battery voltage relative to GND, T _C = -55° C to +125° C	Ceramic	1.0	3.6	V
	Battery voltage relative to GND, T _J = -55° C to +125° C	Plastic	1.0	3.6	V

Notes:

1. If battery is not used, do not connect V_{BATT}.
2. Recommended maximum voltage droop for V_{CCAUX} is 10 mV/ms.
3. The thresholds for Power On Reset are V_{CCINT} > 1.2V, V_{CCAUX} > 2.5V, and V_{CCO} (Bank 4) > 1.5 V.
4. Limit the noise at the power supply to be within 200 mV peak-to-peak.
5. For power bypassing guidelines, see Xilinx Application Note [XAPP623](#).

Table 33: DC Characteristics Over Recommended Operating Conditions

Symbol	Description	Device	Min	Max	Units
V _{DRINT}	Data retention V _{CCINT} voltage	All	1.2		V
V _{DRI}	Data retention V _{CCAUX} voltage	All	2.5		V
I _{REF}	V _{REF} current per bank	All	-10	+10	μA
I _L	Input leakage current	All	-10	+10	μA
C _{IN}	Input capacitance	All		10	pF
I _{RPU}	Pad pull-up (when selected) @ V _{IN} = 0 V, V _{CCO} = 3.3 V (sample tested)	All	Note 1	250	μA
I _{RPD}	Pad pull-down (when selected) @ V _{IN} = 3.6 V (sample tested)	All	Note 1	250	μA
I _{BATT}	Battery supply current	All		100	nA

Notes:

1. Internal pull-up and pull-down resistors guarantee valid logic levels at unconnected input pins. These pull-up and pull-down resistors do not guarantee valid logic levels when input pins are connected to other circuits.

Table 34: Quiescent Supply Current

Symbol	Description	Device	Min	Typical	Max	Units
I_{CCINTQ}	Quiescent V_{CCINT} supply current	XQ2V1000		100	0.50	A
		XQ2V3000	-	200	1.30	
		XQ2V6000		250	1.50	
I_{CCOQ}	Quiescent V_{CCO} supply current ^(1,2)	XQ2V1000		1.0	6.25	mA
		XQ2V3000	-	2.0	6.25	
		XQ2V6000		2.0	6.25	
I_{CCAUXQ}	Quiescent V_{CCAUX} supply current ^(1,2)	XQ2V1000		10	30	mA
		XQ2V3000	-	20	95	
		XQ2V6000		25	95	

Notes:

1. With no output current loads and no active input pull-up resistors. All I/O pins are 3-stated and floating.
2. If DCI or differential signaling is used, more accurate values can be obtained by using the Power Estimator or XPOWER.
3. Data are retained even if V_{CCO} drops to 0 V.
4. Values specified for quiescent supply current parameters are Military Grade.

Power-On Power Supply Requirements

Xilinx FPGAs require a certain amount of supply current during power-on to ensure proper device operation. The actual current consumed depends on the power-on ramp rate of the power supply.

The V_{CCINT} , V_{CCAUX} , and V_{CCO} power supplies shall each ramp on no faster than 200 μ s and no slower than 50 ms. Ramp on is defined as: 0 V_{DC} to minimum supply voltages.

Table 35 shows the minimum current required by QPro Virtex-II devices for proper power on and configuration.

Power supplies can be turned on in any sequence.

If any V_{CCO} bank powers up before V_{CCAUX} , then each bank draws up to 300 mA, worst case, until the V_{CCAUX} powers on¹. This does not harm the device. If the current is limited to the minimum value above, or larger, the device powers on properly after all three supplies have passed through their power on reset threshold voltages.

General Power Supply Requirements

Proper decoupling of all FPGA power supplies is essential. Consult Xilinx Application Note [XAPP623](#) for detailed information on power distribution system design.

V_{CCAUX} powers critical resources in the FPGA. Thus, V_{CCAUX} is especially susceptible to power supply noise.

Changes in V_{CCAUX} voltage outside of 200 mV peak to peak should take place at a rate no faster than 10 mV per millisecond. Techniques to help reduce jitter and period distortion

are provided in Xilinx Answer Record 13756, available at www.support.xilinx.com.

Table 35: Maximum Power On Current Required for QPro Virtex-II Devices

Current	Device (mA)		
	XQ2V1000	XQ2V3000	XQ2V6000
$I_{CCINTMAX}$	500	1300	1500
$I_{CCAUXMAX}$	30	95	95
I_{CCOMAX}	6.25	6.25	6.25

Notes:

1. Values specified for power on current parameters are Military Grade.
2. I_{CCOMAX} values listed here apply to the entire device (all banks).

1. The 300 mA is transient current (peak). It eventually disappears even if V_{CCAUX} does not power up.

DC Input and Output Levels

Values for V_{IL} and V_{IH} are recommended input voltages. Values for I_{OL} and I_{OH} are guaranteed over the recommended operating conditions at the V_{OL} and V_{OH} test points. Only selected standards are tested. These are cho-

sen to ensure that all standards meet their specifications. The selected standards are tested at minimum V_{CCO} with the respective V_{OL} and V_{OH} voltage levels shown. Other standards are sample tested.

Table 36: DC Input and Output Levels

Input/Output Standard	V_{IL}		V_{IH}		V_{OL}	V_{OH}	I_{OL}	I_{OH}
	V, Min	V, Max	V, Min	V, Max	V, Max	V, Min	mA	mA
LVTTL ⁽¹⁾	-0.5	0.8	2.0	3.6	0.4	2.4	24	-24
LVC MOS33	-0.5	0.8	2.0	3.6	0.4	$V_{CCO} - 0.4$	24	-24
LVC MOS25	-0.5	0.7	1.7	2.7	0.4	$V_{CCO} - 0.4$	24	-24
LVC MOS18	-0.5	35% V_{CCO}	65% V_{CCO}	1.95	0.4	$V_{CCO} - 0.4$	16	-16
LVC MOS15	-0.5	35% V_{CCO}	65% V_{CCO}	1.7	0.4	$V_{CCO} - 0.4$	16	-16
PCI33_3	-0.5	30% V_{CCO}	50% V_{CCO}	$V_{CCO} + 0.5$	10% V_{CCO}	90% V_{CCO}	Note 2	Note 2
PCI66_3	-0.5	30% V_{CCO}	50% V_{CCO}	$V_{CCO} + 0.5$	10% V_{CCO}	90% V_{CCO}	Note 2	Note 2
PCI-X	-0.5	Note 2	Note 2	Note 2	Note 2	Note 2	Note 2	Note 2
GTLP	-0.5	$V_{REF} - 0.1$	$V_{REF} + 0.1$	$V_{CCO} + 0.5$	0.6	n/a	36	n/a
GTL	-0.5	$V_{REF} - 0.05$	$V_{REF} + 0.05$	$V_{CCO} + 0.5$	0.4	n/a	40	n/a
HSTL I	-0.5	$V_{REF} - 0.1$	$V_{REF} + 0.1$	$V_{CCO} + 0.5$	0.4	$V_{CCO} - 0.4$	8	-8
HSTL II	-0.5	$V_{REF} - 0.1$	$V_{REF} + 0.1$	$V_{CCO} + 0.5$	0.4	$V_{CCO} - 0.4$	16	-16
HSTL III	-0.5	$V_{REF} - 0.1$	$V_{REF} + 0.1$	$V_{CCO} + 0.5$	0.4	$V_{CCO} - 0.4$	24	-8
HSTL IV	-0.5	$V_{REF} - 0.1$	$V_{REF} + 0.1$	$V_{CCO} + 0.5$	0.4	$V_{CCO} - 0.4$	48	-8
SSTL3 I	-0.5	$V_{REF} - 0.2$	$V_{REF} + 0.2$	$V_{CCO} + 0.5$	$V_{REF} - 0.6$	$V_{REF} + 0.6$	8	-8
SSTL3 II	-0.5	$V_{REF} - 0.2$	$V_{REF} + 0.2$	$V_{CCO} + 0.5$	$V_{REF} - 0.8$	$V_{REF} + 0.8$	16	-16
SSTL2 I	-0.5	$V_{REF} - 0.15$	$V_{REF} + 0.15$	$V_{CCO} + 0.5$	$V_{REF} - 0.65$	$V_{REF} + 0.65$	7.6	-7.6
SSTL2 II	-0.5	$V_{REF} - 0.15$	$V_{REF} + 0.15$	$V_{CCO} + 0.5$	$V_{REF} - 0.80$	$V_{REF} + 0.80$	15.2	-15.2
AGP	-0.5	$V_{REF} - 0.2$	$V_{REF} + 0.2$	$V_{CCO} + 0.5$	10% V_{CCO}	90% V_{CCO}	Note 2	Note 2

Notes:

1. V_{OL} and V_{OH} for lower drive currents are sample tested. The DONE pin is always LVTTL 12 mA.
2. Tested according to the relevant specifications.
3. LVTTL and LVC MOS inputs have approximately 100 mV of hysteresis.

LDT Differential Signal DC Specifications (LDT_25)

Table 37: LDT DC Specifications

DC Parameter	Symbol	Conditions	Min	Typ	Max	Units
Differential Output Voltage	V_{OD}	$R_T = 100 \Omega$ across Q and \bar{Q} signals	500	600	700	mV
Change in V_{OD} Magnitude	ΔV_{OD}		-15		15	mV
Output Common Mode Voltage	V_{OCM}	$R_T = 100 \Omega$ across Q and \bar{Q} signals	560	600	640	mV
Change in V_{OS} Magnitude	ΔV_{OCM}		-15		15	mV
Input Differential Voltage	V_{ID}		200	600	1000	mV
Change in V_{ID} Magnitude	ΔV_{ID}		-15		15	mV
Input Common Mode Voltage	V_{ICM}		500	600	700	mV
Change in V_{ICM} Magnitude	ΔV_{ICM}		-15		15	mV

LVDS DC Specifications (LVDS_33 and LVDS_25)

Table 38: LVDS DC Specifications

DC Parameter	Symbol	Conditions	Min	Typ	Max	Units
Supply Voltage	V_{CCO}			3.3 or 2.5		V
Output High Voltage for Q and \bar{Q}	V_{OH}	$R_T = 100 \Omega$ across Q and \bar{Q} signals			1.575	V
Output Low Voltage for Q and \bar{Q}	V_{OL}	$R_T = 100 \Omega$ across Q and \bar{Q} signals	0.925			V
Differential Output Voltage (Q - \bar{Q}), Q = High ($\bar{Q} - Q$), \bar{Q} = High	V_{ODIFF}	$R_T = 100 \Omega$ across Q and \bar{Q} signals	250	350	400	mV
Output Common-Mode Voltage	V_{OCM}	$R_T = 100 \Omega$ across Q and \bar{Q} signals	1.125	1.2	1.375	V
Differential Input Voltage (Q - \bar{Q}), Q = High ($\bar{Q} - Q$), \bar{Q} = High	V_{IDIFF}	Common-mode input voltage = 1.25 V	100	350	N/A	mV
Input Common-Mode Voltage	V_{ICM}	Differential input voltage = ± 350 mV	0.2	1.25	$V_{CCO} - 0.5$	V

Extended LVDS DC Specifications (LVDS_EXT_33 and LVDS_EXT_25)

Table 39: Extended LVDS DC Specifications

DC Parameter	Symbol	Conditions	Min	Typ	Max	Units
Supply Voltage	V_{CCO}			3.3 or 2.5		V
Output High voltage for Q and \bar{Q}	V_{OH}	$R_T = 100 \Omega$ across Q and \bar{Q} signals			1.785	V
Output Low voltage for Q and \bar{Q}	V_{OL}	$R_T = 100 \Omega$ across Q and \bar{Q} signals	0.705			V
Differential output voltage (Q - \bar{Q}), Q = High ($\bar{Q} - Q$), \bar{Q} = High	V_{ODIFF}	$R_T = 100 \Omega$ across Q and \bar{Q} signals	440		820	mV
Output common-mode voltage	V_{OCM}	$R_T = 100 \Omega$ across Q and \bar{Q} signals	1.125	1.200	1.375	V
Differential input voltage (Q - \bar{Q}), Q = High ($\bar{Q} - Q$), \bar{Q} = High	V_{IDIFF}	Common-mode input voltage = 1.25 V	100	350	N/A	mV
Input common-mode voltage	V_{ICM}	Differential input voltage = ± 350 mV	0.2	1.25	$V_{CCO} - 0.5$	V

LVPECL DC Specifications

These values are valid when driving a 100 Ω differential load only, i.e., a 100 Ω resistor between the two receiver pins. The V_{OH} levels are 200 mV below standard LVPECL levels and are compatible with devices tolerant of lower

common-mode ranges. [Table 40](#) summarizes the DC output specifications of LVPECL. For more information on using LVPECL, see the *Virtex-II User Guide*.

Table 40: LVPECL DC Specifications

DC Parameter	Min	Max	Min	Max	Min	Max	Units
V_{CCO}	3.0		3.3		3.6		V
V_{OH}	1.8	2.11	1.92	2.28	2.13	2.41	V
V_{OL}	0.96	1.27	1.06	1.43	1.30	1.57	V
V_{IH}	1.49	2.72	1.49	2.72	1.49	2.72	V
V_{IL}	0.86	2.125	0.86	2.125	0.86	2.125	V
Differential Input Voltage	0.3	–	0.3	–	0.3	–	V

QPro Virtex-II Switching Characteristics

Switching characteristics in this document are specified on a per-speed-grade basis and can be designated as Advance, Preliminary, or Production. Each designation is defined as follows:

Advance: These speed files are based on simulations only and are typically available soon after device design specifications are frozen. Although speed grades with this designation are considered relatively stable and conservative, some under-reporting might still occur.

Preliminary: These speed files are based on complete ES (engineering sample) silicon characterization. Devices and speed grades with this designation are intended to give a better indication of the expected performance of production silicon. The probability of under-reporting delays is greatly reduced as compared to Advance data.

Production: These speed files are released once enough production silicon of a particular device family member has been characterized to provide full correlation between speed files and devices over numerous production lots. There is no under-reporting of delays, and customers receive formal notification of any subsequent changes. Typ-

ically, the slowest speed grades transition to Production before faster speed grades.

Since individual family members are produced at different times, the migration from one category to another depends completely on the status of the fabrication process for each device. [Table 41](#) correlates the current status of each QPro Virtex-II device with a corresponding speed grade designation.

Table 41: QPro Virtex-II Device Speed Grade Designations

Device	Speed Grade Designations		
	Advance	Preliminary	Production
XQ2V1000			–4
XQ2V3000			–4
XQ2V6000			–4

All specifications are always representative of worst-case supply voltage and junction temperature conditions.

Testing of Switching Characteristics

All devices are 100% functionally tested. Internal timing parameters are derived from measuring internal test patterns. Listed below are representative values. For more specific, more precise, and worst-case guaranteed data,

use the values reported by the Xilinx static timing analyzer and back-annotate to the simulation net list. Unless otherwise noted, values apply to all QPro Virtex-II devices.

IOB Input Switching Characteristics

Input delays associated with the pad are specified for LVTTTL levels. For other standards, adjust the delays with

the values shown in **IOB Input Switching Characteristics Standard Adjustments**, page 53.

Table 42: IOB Input Switching Characteristics

Description	Symbol	Device	Min	Max	Units
Propagation Delays					
Pad to I output, no delay	T_{IOPI}	All	-	0.88	ns
Pad to I output, with delay	T_{IOPID}	XQ2V1000	-	2.43	ns
		XQ2V3000	-	2.49	ns
		XQ2V6000	-	2.66	ns
Propagation Delays					
Pad to output IQ via transparent latch, no delay	T_{IOPLI}	All	-	1.05	ns
Pad to output IQ via transparent latch, with delay	T_{IOPLID}	XQ2V1000	-	4.09	ns
		XQ2V3000	-	4.20	ns
		XQ2V6000	-	4.55	ns
Clock CLK to output IQ	T_{IOCKIQ}	All	-	0.77	ns
Setup and Hold Times with Respect to Clock at IOB Input Register					
Pad, no delay	T_{IOPICK}/T_{IOICKP}	All	1.06/-0.45	-	ns
Pad, with delay	$T_{IOPICKD}/T_{IOICKPD}$	XQ2V1000	4.10/-2.58	-	ns
		XQ2V3000	4.22/-2.66	-	ns
		XQ2V6000	4.56/-2.90	-	ns
ICE input	$T_{IOICECK}/T_{IOICKICE}$	All	0.24/ 0.04	-	ns
SR input (IFF, synchronous)	$T_{IOSRCKI}$	All	0.34	-	ns
Set/Reset Delays					
SR input to IQ (asynchronous)	T_{IOSRIQ}	All		1.40	ns
GSR to output IQ	T_{GSRQ}	All		6.88	ns

Notes:

- Input timing for LVTTTL is measured at 1.4 V. For other I/O standards, see [Table 46](#).

IOB Input Switching Characteristics Standard Adjustments

Table 43: IOB Input Switching Characteristics Standard Adjustments

Description	Symbol	Standard	Value	Units
Data Input Delay Adjustments				
Standard-specific data input delay adjustments	T_{ILVTTL}	LVTTTL	0.00	ns
	$T_{ILVCMOS33}$	LVCMOS33	0.00	ns
	$T_{ILVCMOS25}$	LVCMOS25	0.12	ns
	$T_{ILVCMOS18}$	LVCMOS18	0.49	ns
	$T_{ILVCMOS15}$	LVCMOS15	1.15	ns
	T_{ILVDS_25}	LVDS_25	0.69	ns
	T_{ILVDS_33}	LVDS_33	0.69	ns
	$T_{ILVPECL_33}$	LVPECL	0.69	ns
	T_{IPCI33_3}	PCI, 33 MHz, 3.3 V	0.00	ns
	T_{IPCI66_3}	PCI, 66 MHz, 3.3 V	0.00	ns
	T_{IPCIX}	PCI-X, 133 MHz, 3.3 V	0.00	ns
	T_{IGTL}	GTL	0.48	ns
	T_{IGTLP}	GTLP	0.48	ns
	T_{IHSTL_I}	HSTL I	0.48	ns
	T_{IHSTL_II}	HSTL II	0.48	ns
	T_{IHSTL_III}	HSTL III	0.48	ns
	T_{IHSTL_IV}	HSTL IV	0.48	ns
	$T_{IHSTL_I_18}$	HSTL I_18	0.48	ns
	$T_{IHSTL_II_18}$	HSTL II_18	0.48	ns
	$T_{IHSTL_III_18}$	HSTL III_18	0.48	ns
	$T_{IHSTL_IV_18}$	HSTL IV_18	0.48	ns
	T_{ISSTL2_I}	SSTL2 I	0.48	ns
	T_{ISSTL2_II}	SSTL2 II	0.48	ns
	T_{ISSTL3_I}	SSTL3 I	0.40	ns
	T_{ISSTL3_II}	SSTL3 II	0.40	ns
	T_{IAGP}	AGP	0.40	ns
	T_{ILVDCI_33}	LVDCI_33	0.00	ns
	T_{ILVDCI_25}	LVDCI_25	0.12	ns
	T_{ILVDCI_18}	LVDCI_18	0.49	ns
	T_{ILVDCI_15}	LVDCI_15	1.14	ns
	$T_{ILVDCI_DV2_33}$	LVDCI_DV2_33	0.00	ns
	$T_{ILVDCI_DV2_25}$	LVDCI_DV2_25	0.12	ns
	$T_{ILVDCI_DV2_18}$	LVDCI_DV2_18	0.49	ns

Table 43: IOB Input Switching Characteristics Standard Adjustments (Continued)

Description	Symbol	Standard	Value	Units
Standard-specific data input delay adjustments	$T_{ILVDCI_DV2_15}$	LVDCI_DV2_15	1.14	ns
	T_{IGTL_DCI}	GTL_DCI	0.48	ns
	T_{IGTLP_DCI}	GTL_P_DCI	0.48	ns
	$T_{IHSTL_I_DCI}$	HSTL_I_DCI	0.48	ns
	$T_{IHSTL_II_DCI}$	HSTL_II_DCI	0.48	ns
	$T_{IHSTL_III_DCI}$	HSTL_III_DCI	0.48	ns
	$T_{IHSTL_IV_DCI}$	HSTL_IV_DCI	0.48	ns
	$T_{IHSTL_I_DCI_18}$	HSTL_I_DCI_18	0.48	ns
	$T_{IHSTL_II_DCI_18}$	HSTL_II_DCI_18	0.48	ns
	$T_{IHSTL_III_DCI_18}$	HSTL_III_DCI_18	0.48	ns
	$T_{IHSTL_IV_DCI_18}$	HSTL_IV_DCI_18	0.48	ns
	$T_{ISSTL2_I_DCI}$	SSTL2_I_DCI	0.48	ns
	$T_{ISSTL2_II_DCI}$	SSTL2_II_DCI	0.48	ns
	$T_{ISSTL3_I_DCI}$	SSTL3_I_DCI	0.40	ns
	$T_{ISSTL3_II_DCI}$	SSTL3_II_DCI	0.40	ns
	$T_{ILD T_25}$	LDT_25	0.56	ns
	T_{IULVDS_25}	ULVDS_25	0.56	ns

Notes:

1. Input timing for LVTTTL is measured at 1.4 V. For other I/O standards, see [Table 46](#).

IOB Output Switching Characteristics

Output delays terminating at a pad are specified for LVTTTL with 12 mA drive and fast slew rate. For other standards, adjust the delays with the values shown in **IOB Output Switching Characteristics Standard Adjustments**, page 56.

Table 44: IOB Output Switching Characteristics

Description	Symbol	Min	Max	Units
Propagation Delays				
O input to Pad	T_{IOOP}		1.74	ns
O input to Pad via transparent latch	T_{IOOLP}		2.11	ns
3-State Delays				
T input to Pad high-impedance ⁽¹⁾	T_{IOTHZ}		0.64	ns
T input to valid data on Pad	T_{IOTON}		1.67	ns
T input to Pad high-impedance via transparent latch ⁽¹⁾	$T_{IOTLPHZ}$		1.01	ns
T input to valid data on Pad via transparent latch	$T_{IOTLPON}$		2.04	ns
GTS to Pad high-impedance ⁽¹⁾	T_{GTS}		5.98	ns
Sequential Delays				
Clock CLK to Pad	T_{IOCKP}		2.15	ns
Clock CLK to Pad high-impedance (synchronous) ⁽¹⁾	T_{IOCKHZ}		1.20	ns
Clock CLK to valid data on Pad (synchronous)	T_{IOCKON}		2.22	ns
Setup and Hold Times Before/After Clock CLK				
O input	T_{IOOCK}/T_{IOCKO}	0.39/-0.11		ns
OCE input	$T_{IOOCECK}/T_{IOCKOCE}$	0.24/-0.08		ns
SR input (OFF)	$T_{IOSRCKO}/T_{IOCKOSR}$	0.34/-0.07		ns
3-State Setup Times, T input	T_{IOTCK}/T_{IOCKT}	0.35/-0.08		ns
3-State Setup Times, TCE input	$T_{IOTCECK}/T_{IOCKTCE}$	0.24/-0.08		ns
3-State Setup Times, SR input (TFF)	$T_{IOSRCKT}/T_{IOCKTSR}$	0.34/-0.07		ns
Set/Reset Delays				
SR input to Pad (asynchronous)	T_{IOSRP}		2.98	ns
SR input to Pad high-impedance (asynchronous) ⁽¹⁾	T_{IOSRHZ}		1.92	ns
SR input to valid data on Pad (asynchronous)	T_{IOSRON}		2.95	ns
GSR to Pad	T_{IOGSRQ}		6.88	ns

Notes:

- The 3-state turn-off delays should not be adjusted.

IOB Output Switching Characteristics Standard Adjustments

Output delays terminating at a pad are specified for LVTTTL with 12 mA drive and fast slew rate. For other standards, adjust the delays by the values shown.

Table 45: IOB Output Switching Characteristics Standard Adjustments

Description	Symbol	Standard	Value	Units
Output Delay Adjustments				
Standard-specific adjustments for output delays terminating at pads (based on standard capacitive load, Csl)	T _{OLVTTTL_S2}	LVTTTL, Slow, 2 mA	10.68	ns
	T _{OLVTTTL_S4}	4 mA	6.55	ns
	T _{OLVTTTL_S6}	6 mA	4.66	ns
	T _{OLVTTTL_S8}	8 mA	3.26	ns
	T _{OLVTTTL_S12}	12 mA	2.63	ns
	T _{OLVTTTL_S16}	16 mA	1.93	ns
	T _{OLVTTTL_S24}	24 mA	1.43	ns
	T _{OLVTTTL_F2}	LVTTTL, Fast, 2 mA	7.39	ns
	T _{OLVTTTL_F4}	4 mA	3.17	ns
	T _{OLVTTTL_F6}	6 mA	1.78	ns
	T _{OLVTTTL_F8}	8 mA	0.52	ns
	T _{OLVTTTL_F12}	12 mA	0.00	ns
	T _{OLVTTTL_F16}	16 mA	-0.15	ns
	T _{OLVTTTL_F24}	24 mA	-0.26	ns
	T _{OLVDS_25}	LVDS	-0.36	ns
	T _{OLVDS_33}	LVDS	-0.29	ns
	T _{OLVDSEXT_25}	LVDS	-0.21	ns
	T _{OLVDSEXT_33}	LVDS	-0.19	ns
	T _{OLDT_25}	LDT	-0.23	ns
	T _{OBLVDS_25}	BLVDS	0.76	ns
	T _{OULVDS_25}	ULVDS	-0.23	ns
	T _{OLVPECL_33}	LVPECL	0.33	ns
	T _{OPCI33_3}	PCI, 33 MHz, 3.3 V	1.31	ns
	T _{OPCI66_3}	PCI, 66 MHz, 3.3 V	-0.01	ns
	T _{OPCIX}	PCI-X, 133 MHz, 3.3 V	-0.01	ns
	T _{OGTL}	GTL	-0.36	ns
	T _{OGTLP}	GTLP	-0.20	ns
	T _{OHSTL_I}	HSTL I	0.29	ns
	T _{OHSTL_II}	HSTL II	-0.17	ns
	T _{OHSTL_III}	HSTL III	-0.19	ns
	T _{OHSTL_IV}	HSTL IV	-0.45	ns
	T _{OHSTL_I_18}	HSTL I_18	-0.04	ns
	T _{OHSTL_II_18}	HSTL II_18	-0.20	ns
T _{OHSTL_III_18}	HSTL III_18	-0.18	ns	

Table 45: IOB Output Switching Characteristics Standard Adjustments (Continued)

Description	Symbol	Standard	Value	Units
Standard-specific adjustments for output delays terminating at pads (based on standard capacitive load, Csl)	$T_{OHSTL_IV_18}$	HSTL IV_18	-0.44	ns
	T_{OSSTL2_I}	SSTL2 I	0.24	ns
	T_{OSSTL2_II}	SSTL2 II	-0.18	ns
	T_{OSSTL3_I}	SSTL3 I	0.33	ns
	T_{OSSTL3_II}	SSTL3 II	-0.05	ns
	T_{OAGP}	AGP	-0.31	ns
	$T_{OLVCMOS33_S2}$	LVC MOS33, Slow, 2 mA	8.70	ns
	$T_{OLVCMOS33_S4}$	4 mA	4.95	ns
	$T_{OLVCMOS33_S6}$	6 mA	3.78	ns
	$T_{OLVCMOS33_S8}$	8 mA	2.60	ns
	$T_{OLVCMOS33_S12}$	12 mA	2.16	ns
	$T_{OLVCMOS33_S16}$	16 mA	1.40	ns
	$T_{OLVCMOS33_S24}$	24 mA	1.34	ns
	$T_{OLVCMOS33_F2}$	LVC MOS33, Fast, 2 mA	6.60	ns
	$T_{OLVCMOS33_F4}$	4 mA	2.81	ns
	$T_{OLVCMOS33_F6}$	6 mA	1.45	ns
	$T_{OLVCMOS33_F8}$	8 mA	0.54	ns
	$T_{OLVCMOS33_F12}$	12 mA	0.31	ns
	$T_{OLVCMOS33_F16}$	16 mA	-0.15	ns
	$T_{OLVCMOS33_F24}$	24 mA	-0.23	ns
	$T_{OLVCMOS25_S2}$	LVC MOS25, Slow, 2 mA	10.33	ns
	$T_{OLVCMOS25_S4}$	4 mA	5.67	ns
	$T_{OLVCMOS25_S6}$	6 mA	5.13	ns
	$T_{OLVCMOS25_S8}$	8 mA	4.38	ns
	$T_{OLVCMOS25_S12}$	12 mA	3.22	ns
	$T_{OLVCMOS25_S16}$	16 mA	2.67	ns
	$T_{OLVCMOS25_S24}$	24 mA	2.27	ns
	$T_{OLVCMOS25_F2}$	LVC MOS25, Fast, 2 mA	4.60	ns
	$T_{OLVCMOS25_F4}$	4 mA	1.30	ns
	$T_{OLVCMOS25_F6}$	6 mA	0.81	ns
	$T_{OLVCMOS25_F8}$	8 mA	0.37	ns
	$T_{OLVCMOS25_F12}$	12 mA	0.03	ns
	$T_{OLVCMOS25_F16}$	16 mA	-0.21	ns
	$T_{OLVCMOS25_F24}$	24 mA	-0.40	ns
	$T_{OLVCMOS18_S2}$	LVC MOS18, Slow, 2 mA	17.71	ns
	$T_{OLVCMOS18_S4}$	4 mA	11.57	ns
	$T_{OLVCMOS18_S6}$	6 mA	8.53	ns
	$T_{OLVCMOS18_S8}$	8 mA	7.78	ns

Table 45: IOB Output Switching Characteristics Standard Adjustments (Continued)

Description	Symbol	Standard	Value	Units
Standard-specific adjustments for output delays terminating at pads (based on standard capacitive load, Csl)	T _{OLVCMOS18_S12}	12 mA	6.28	ns
	T _{OLVCMOS18_S16}	16 mA	6.02	ns
	T _{OLVCMOS18_F2}	LVC MOS18, Fast, 2 mA	6.30	ns
	T _{OLVCMOS18_F4}	4 mA	2.15	ns
	T _{OLVCMOS18_F6}	6 mA	0.94	ns
	T _{OLVCMOS18_F8}	8 mA	0.80	ns
	T _{OLVCMOS18_F12}	12 mA	0.30	ns
	T _{OLVCMOS18_F16}	16 mA	0.26	ns
	T _{OLVCMOS15_S2}	LVC MOS15, Slow, 2 mA	21.50	ns
	T _{OLVCMOS15_S4}	4 mA	14.48	ns
	T _{OLVCMOS15_S6}	6 mA	13.66	ns
	T _{OLVCMOS15_S8}	8 mA	11.06	ns
	T _{OLVCMOS15_S12}	12 mA	10.25	ns
	T _{OLVCMOS15_S16}	16 mA	9.31	ns
	T _{OLVCMOS15_F2}	LVC MOS15, Fast, 2 mA	5.78	ns
	T _{OLVCMOS15_F4}	4 mA	2.27	ns
	T _{OLVCMOS15_F6}	6 mA	1.66	ns
	T _{OLVCMOS15_F8}	8 mA	1.05	ns
	T _{OLVCMOS15_F12}	12 mA	0.84	ns
	T _{OLVCMOS15_F16}	16 mA	0.75	ns
	T _{OLVDCI_33}	LVDCI_33	0.84	ns
	T _{OLVDCI_25}	LVDCI_25	0.88	ns
	T _{OLVDCI_18}	LVDCI_18	0.95	ns
	T _{OLVDCI_15}	LVDCI_15	2.06	ns
	T _{OLVDCI_DV2_33}	LVDCI_DV2_33	0.13	ns
	T _{OLVDCI_DV2_25}	LVDCI_DV2_25	0.03	ns
	T _{OLVDCI_DV2_18}	LVDCI_DV2_18	0.48	ns
	T _{OLVDCI_DV2_15}	LVDCI_DV2_15	1.36	ns
	T _{OGTL_DCI}	GTL_DCI	-0.35	ns
	T _{OGTLP_DCI}	GTL_P_DCI	-0.17	ns
	T _{OHSTL_I_DCI}	HSTL_I_DCI	0.26	ns
	T _{OHSTL_II_DCI}	HSTL_II_DCI	0.07	ns
	T _{OHSTL_III_DCI}	HSTL_III_DCI	-0.20	ns
	T _{OHSTL_IV_DCI}	HSTL_IV_DCI	-0.52	ns
	T _{OHSTL_I_DCI_18}	HSTL_I_DCI_18	0.06	ns
	T _{OHSTL_II_DCI_18}	HSTL_II_DCI_18	-0.03	ns
	T _{OHSTL_III_DCI_18}	HSTL_III_DCI_18	-0.16	ns
	T _{OHSTL_IV_DCI_18}	HSTL_IV_DCI_18	-0.47	ns

Table 45: IOB Output Switching Characteristics Standard Adjustments (Continued)

Description	Symbol	Standard	Value	Units
Standard-specific adjustments for output delays terminating at pads (based on standard capacitive load, Csl)	$T_{OSSTL2_I_DCI}$	SSTL2_I_DCI	0.14	ns
	$T_{OSSTL2_II_DCI}$	SSTL2_II_DCI	-0.11	ns
	$T_{OSSTL3_I_DCI}$	SSTL3_I_DCI	0.17	ns
	$T_{OSSTL3_II_DCI}$	SSTL3_II_DCI	0.09	ns

I/O Standard Adjustment Measurement Methodology

Input Delay Measurements

Table 46 shows the test setup parameters used for measuring Input standard adjustments (see Table 43, page 53).

Table 46: Input Delay Measurement Methodology

Standard	$V_L^{(1)}$	$V_H^{(1)}$	$V_{MEAS}^{(3,4)}$	$V_{REF}^{(2,4)}$
LVTTTL	0	3.0	1.4	–
LVCOS33	0	3.3	1.65	–
LVCOS25	0	2.5	1.25	–
LVCOS18	0	1.8	0.9	–
LVCOS15	0	1.5	0.75	–
PCI33_3	Per PCI Specification			–
PCI66_3	Per PCI Specification			–
PCI-X	Per PCI-X Specification			–
GTL	$V_{REF} - 0.2$	$V_{REF} + 0.2$	V_{REF}	0.80
GTL P	$V_{REF} - 0.2$	$V_{REF} + 0.2$	V_{REF}	1.0
HSTL Class I	$V_{REF} - 0.5$	$V_{REF} + 0.5$	V_{REF}	0.75
HSTL Class II	$V_{REF} - 0.5$	$V_{REF} + 0.5$	V_{REF}	0.75
HSTL Class III	$V_{REF} - 0.5$	$V_{REF} + 0.5$	V_{REF}	0.90
HSTL Class IV	$V_{REF} - 0.5$	$V_{REF} + 0.5$	V_{REF}	0.90
SSTL3 Class I & II	$V_{REF} - 1.00$	$V_{REF} + 1.00$	V_{REF}	1.5
SSTL2 Class I & II	$V_{REF} - 0.75$	$V_{REF} + 0.75$	V_{REF}	1.25
AGP-2X	$V_{REF} - (0.2 \times V_{CC0})$	$V_{REF} + (0.2 \times V_{CC0})$	V_{REF}	Per AGP Spec
LVDS25	1.2 – 0.125	1.2 + 0.125	1.2	
LVDS33	1.2 – 0.125	1.2 + 0.125	1.2	
LVDS25	1.2 – 0.125	1.2 + 0.125	1.2	
LVDS25	1.2 – 0.125	1.2 + 0.125	1.2	
ULVDS25	0.6 – 0.125	0.6 + 0.125	0.6	
LDT25	0.6 – 0.125	0.6 + 0.125	0.6	
LVPECL	1.6 – 0.3	1.6 + 0.3	1.6	

Notes:

- Input waveform switches between V_L and V_H .
- Measurements are made at typical, minimum, and maximum V_{REF} values. Reported delays reflect worst case of these measurements. V_{REF} values listed are typical. See [Virtex-II Platform FPGA User Guide](#) for min/max specifications.
- Input voltage level from which measurement starts.
- Note that this is an input voltage reference that bears no relation to the V_{REF} / V_{MEAS} parameters found in IBIS models and/or noted in Figure 51.

Output Delay Measurements

Output delays are measured using a Tektronix P6245 TDS500/600 probe (< 1 pf) across approximately 4" of FR4 microstrip trace. Standard termination was used for all testing. (See [Virtex-II Platform FPGA User Guide](#) for details.) The propagation delay of the 4" trace is characterized separately and subtracted from the final measurement, and is therefore not included in the generalized test setup shown in Figure 51.

Measurements and test conditions are reflected in the IBIS models except where the IBIS format precludes it. (IBIS models can be found on the web at http://support.xilinx.com/support/sw_ibis.htm.) Parameters V_{REF} , R_{REF} , C_{REF} , and V_{MEAS} fully describe the test conditions for each I/O standard. The most accurate prediction of propagation delay in any given application can be obtained through IBIS simulation, using the following method:

- Simulate the output driver of choice into the generalized test setup, using values from Table 47.
- Record the time to V_{MEAS} .
- Simulate the output driver of choice into the actual PCB trace and load, using the appropriate IBIS model or capacitance value to represent the load.
- Record the time to V_{MEAS} .
- Compare the results of steps 2 and 4. The increase or decrease in delay should be added to or subtracted from the I/O Output Standard Adjustment value (Table 45) to yield the actual worst-case propagation delay (clock-to-input) of the PCB trace.

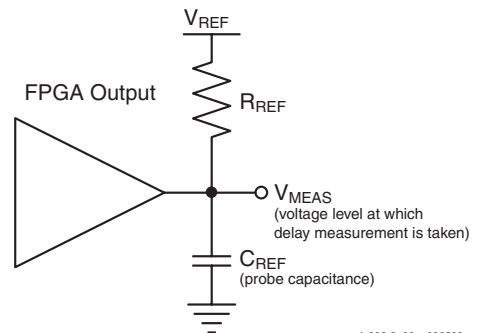

ds083-3_06a_092503

Figure 51: Generalized Test Setup

Table 47: Output Delay Measurement Methodology

Standard	R _{REF} (ohms)	C _{REF} ⁽¹⁾ (pF)	V _{MEAS} (V)	V _{REF} (V)
LVTTTL (all)	1M	0	1.4	0
LVCOS33	1M	0	1.65	0
LVCOS25	1M	0	1.25	0
LVCOS18	1M	0	0.9	0
LVCOS15	1M	0	0.75	0
PCI33_3 - rising edge	25	0	0.94	0
PCI33_3 - falling edge	25	0	2.03	3.3
PCI66_3 - rising edge	25	0	0.94	0
PCI66_3 - falling edge	25	0	2.03	3.3
PCI-X - rising edge	25	0	0.94	
PCI-X - falling edge	25	0	2.03	3.3
GTL	25	0	0.8	1.2
GTL P	25	0	1.0	1.5
HSTL Class I	50	0	V _{REF}	0.75
HSTL Class II	25	0	V _{REF}	0.75
HSTL Class III	50	0	0.9	1.5
HSTL Class IV	25	0	0.9	1.5
HSTL18 Class I	50	0	V _{REF}	0.9
HSTL18 Class II	25	0	V _{REF}	0.9
HSTL18 Class III	50	0	1.1	1.8
HSTL18 Class IV	25	0	1.1	1.8
SSTL3 Class I	50	0	V _{REF}	1.5
SSTL3 Class II	25	0	V _{REF}	1.5
SSTL2 Class I	50	0	V _{REF}	1.25
SSTL2 Class II	25	0	V _{REF}	1.25
SSTL18 Class I	50	0	V _{REF}	0.9
SSTL18 Class II	25	0	V _{REF}	0.9
AGP-2X - rising edge	50	0	0.94	0
AGP-2X - falling edge	50	0	2.03	3.3

Table 47: Output Delay Measurement Methodology

Standard	R _{REF} (ohms)	C _{REF} ⁽¹⁾ (pF)	V _{MEAS} (V)	V _{REF} (V)
LVDS25	50	0	V _{REF}	1.2
LVDS25EXT25	50	0	V _{REF}	1.2
LVDS33	50	0	V _{REF}	1.2
LVDS25EXT33	50	0	V _{REF}	1.2
BLVDS	1M	0	1.2	0
LDT_25	50	0	V _{REF}	0.6
LVPECL25	1M	0	1.23	0
LVDCI33	1M	0	1.65	0
LVDCI25	1M	0	1.25	0
LVDCI18	1M	0	0.9	0
LVDCI15	1M	0	0.75	0
HSTL DCI Class I	50	0	V _{REF}	0.75
HSTL DCI Class II	50	0	V _{REF}	0.75
HSTL DCI Class III	50	0	0.9	1.5
HSTL DCI Class IV	50	0	0.9	1.5
HSTL18 DCI Class I	50	0	V _{REF}	0.9
HSTL18 DCI Class II	50	0	V _{REF}	0.9
HSTL18 DCI Class III	50	0	1.1	1.8
HSTL18 DCI Class IV	50	0	1.1	1.8
SSTL3 DCI Class I	50	0	V _{REF}	1.5
SSTL3 DCI Class II	50	0	V _{REF}	1.5
SSTL2 DCI Class I	50	0	V _{REF}	1.25
SSTL2 DCI Class II	50	0	V _{REF}	1.25
SSTL18 DCI Class I	50	0	V _{REF}	0.9
SSTL18 DCI Class II	50	0	V _{REF}	0.9
GTL DCI	50	0	0.8	1.2
GTL P DCI	50	0	1.0	1.5

Notes:

1. C_{REF} is the capacitance of the probe, nominally 0 pF.

Clock Distribution Switching Characteristics

Table 48: Clock Distribution Switching Characteristics

Description	Symbol	Value	Units
Global Clock Buffer I input to O output	T_{GIO}	0.59	ns

CLB Switching Characteristics

Delays originating at F/G inputs vary slightly according to the input used (see Figure 49). The values listed below are worst-case. Precise values are provided by the timing analyzer.

Table 49: CLB Switching Characteristics

Description	Symbol	Min	Max	Units
Combinatorial Delays				
4-input function: F/G inputs to X/Y outputs	T_{ILO}	-	0.44	ns
5-input function: F/G inputs to F5 output	T_{IF5}	-	0.72	ns
5-input function: F/G inputs to X output	T_{IF5X}	-	0.95	ns
FXINA or FXINB inputs to Y output via MUXFX	T_{IFXY}	-	0.45	ns
FXINA input to FX output via MUXFX	T_{INAFX}	-	0.32	ns
FXINB input to FX output via MUXFX	T_{INBFX}	-	0.32	ns
SOPIN input to SOPOUT output via ORCY	T_{SOPSOP}	-	0.44	ns
Incremental delay routing through transparent latch to XQ/YQ outputs	T_{IFNCTL}	-	0.51	ns
Sequential Delays				
FF Clock CLK to XQ/YQ outputs	T_{CKO}	-	0.57	ns
Latch Clock CLK to XQ/YQ outputs	T_{CKLO}	-	0.68	ns
Setup and Hold Times Before/After Clock CLK				
BX/BY inputs	T_{DICK}/T_{CKDI}	0.37/-0.09	-	ns
DY inputs	T_{DYCK}/T_{CKDY}	0.37/-0.09	-	ns
DX inputs	T_{DXQK}/T_{CKDX}	0.37/-0.09	-	ns
CE input	T_{CECK}/T_{CKCE}	0.24/-0.08	-	ns
SR/BY inputs (synchronous)	T_{SRCK}/T_{SCKR}	0.26/-0.03	-	ns
Clock CLK				
Minimum Pulse Width, High	T_{CH}	0.77	-	ns
Minimum Pulse Width, Low	T_{CL}	0.77	-	ns
Set/Reset				
Minimum Pulse Width, SR/BY inputs	T_{RPW}	0.77	-	ns
Delay from SR/BY inputs to XQ/YQ outputs (asynchronous)	T_{RQ}	-	1.34	ns
Toggle Frequency (MHz) (for export control)	F_{TOG}	-	650	MHz

CLB Distributed RAM Switching Characteristics

Table 50: CLB Distributed RAM Switching Characteristics

Description	Symbol	Min	Max	Units
Sequential Delays				
Clock CLK to X/Y outputs (WE active) in 16 x 1 mode	$T_{SHCKO16}$	-	2.05	ns
Clock CLK to X/Y outputs (WE active) in 32 x 1 mode	$T_{SHCKO32}$	-	2.49	ns
Clock CLK to F5 output	$T_{SHCKOF5}$	-	2.23	ns
Setup and Hold Times Before/After Clock CLK				
BX/BY data inputs (DIN)	T_{DS}/T_{DH}	0.67/-0.11	-	ns
F/G address inputs	T_{AS}/T_{AH}	0.50/ 0.00	-	ns
SR input (WS)	T_{WES}/T_{WEH}	0.53/-0.01	-	ns
Clock CLK				
Minimum Pulse Width, High	T_{WPH}	0.72	-	ns
Minimum Pulse Width, Low	T_{WPL}	0.72	-	ns
Minimum clock period to meet address write cycle time	T_{WC}	1.44	-	ns

CLB Shift Register Switching Characteristics

Table 51: CLB Shift Register Switching Characteristics

Description	Symbol	Min	Max	Units
Sequential Delays				
Clock CLK to X/Y outputs	T_{REG}	-	2.92	ns
Clock CLK to X/Y outputs	T_{REG32}	-	3.35	ns
Clock CLK to XB output via MC15 LUT output	T_{REGXB}	-	2.82	ns
Clock CLK to YB output via MC15 LUT output	T_{REGYB}	-	2.75	ns
Clock CLK to Shiftout	T_{CKSH}	-	2.43	ns
Clock CLK to F5 output	T_{REGF5}	-	3.09	ns
Setup and Hold Times Before/After Clock CLK				
BX/BY data inputs (DIN)	T_{SRLDS}/T_{SRLDH}	0.67/-0.09	-	ns
SR input (WS)	T_{WSS}/T_{WSH}	0.24/-0.08	-	ns
Clock CLK				
Minimum Pulse Width, High	T_{SRPH}	0.72	-	ns
Minimum Pulse Width, Low	T_{SRPL}	0.72	-	ns

Multiplier Switching Characteristics

Table 52 and Table 53 provide timing information for QPro Virtex-II multiplier blocks, available in stepping revisions of QPro Virtex-II devices. For more information on stepping revisions, availability, and ordering instructions, see your local sales representative.

Table 52: Enhanced Multiplier Switching Characteristics

Description	Symbol	Min	Max	Units
Propagation Delay to Output Pin				
Input to Pin 35	T_{MULT_P35}	-	5.91	ns
Input to Pin 34	T_{MULT_P34}	-	5.79	ns
Input to Pin 33	T_{MULT_P33}	-	5.66	ns
Input to Pin 32	T_{MULT_P32}	-	5.54	ns
Input to Pin 31	T_{MULT_P31}	-	5.42	ns
Input to Pin 30	T_{MULT_P30}	-	5.29	ns
Input to Pin 29	T_{MULT_P29}	-	5.17	ns
Input to Pin 28	T_{MULT_P28}	-	5.05	ns
Input to Pin 27	T_{MULT_P27}	-	4.92	ns
Input to Pin 26	T_{MULT_P26}	-	4.80	ns
Input to Pin 25	T_{MULT_P25}	-	4.68	ns
Input to Pin 24	T_{MULT_P24}	-	4.56	ns
Input to Pin 23	T_{MULT_P23}	-	4.43	ns
Input to Pin 22	T_{MULT_P22}	-	4.31	ns
Input to Pin 21	T_{MULT_P21}	-	4.19	ns
Input to Pin 20	T_{MULT_P20}	-	4.06	ns
Input to Pin 19	T_{MULT_P19}	-	3.94	ns
Input to Pin 18	T_{MULT_P18}	-	3.82	ns
Input to Pin 17	T_{MULT_P17}	-	3.69	ns
Input to Pin 16	T_{MULT_P16}	-	3.57	ns
Input to Pin 15	T_{MULT_P15}	-	3.45	ns
Input to Pin 14	T_{MULT_P14}	-	3.33	ns
Input to Pin 13	T_{MULT_P13}	-	3.20	ns
Input to Pin 12	T_{MULT_P12}	-	3.08	ns
Input to Pin 11	T_{MULT_P11}	-	2.96	ns
Input to Pin 10	T_{MULT_P10}	-	2.83	ns
Input to Pin 9	T_{MULT_P9}	-	2.71	ns
Input to Pin 8	T_{MULT_P8}	-	2.59	ns
Input to Pin 7	T_{MULT_P7}	-	2.46	ns
Input to Pin 6	T_{MULT_P6}	-	2.34	ns
Input to Pin 5	T_{MULT_P5}	-	2.22	ns
Input to Pin 4	T_{MULT_P4}	-	2.10	ns
Input to Pin 3	T_{MULT_P3}	-	1.97	ns
Input to Pin 2	T_{MULT_P2}	-	1.85	ns
Input to Pin 1	T_{MULT_P1}	-	1.73	ns
Input to Pin 0	T_{MULT_P0}	-	1.60	ns

Table 53: Pipelined Multiplier Switching Characteristics

Description	Symbol	Min	Max	Units
Setup and Hold Times Before/After Clock				
Data Inputs	$T_{MULIDCK}/T_{MULCKID}$	-	3.89/0.00	ns
Clock Enable	$T_{MULIDCK_CE}/T_{MULCKID_CE}$	-	0.86/0.00	ns
Reset	$T_{MULIDCK_RST}/T_{MULCKID_RST}$	-	0.86/0.00	ns
Clock to Output Pin				
Clock to Pin 35	T_{MULTCK_P35}	-	3.74	ns
Clock to Pin 34	T_{MULTCK_P34}	-	3.61	ns
Clock to Pin 33	T_{MULTCK_P33}	-	3.49	ns
Clock to Pin 32	T_{MULTCK_P32}	-	3.37	ns
Clock to Pin 31	T_{MULTCK_P31}	-	3.25	ns
Clock to Pin 30	T_{MULTCK_P30}	-	3.12	ns
Clock to Pin 29	T_{MULTCK_P29}	-	3.00	ns
Clock to Pin 28	T_{MULTCK_P28}	-	2.88	ns
Clock to Pin 27	T_{MULTCK_P27}	-	2.75	ns
Clock to Pin 26	T_{MULTCK_P26}	-	2.63	ns
Clock to Pin 25	T_{MULTCK_P25}	-	2.51	ns
Clock to Pin 24	T_{MULTCK_P24}	-	2.38	ns
Clock to Pin 23	T_{MULTCK_P23}	-	2.26	ns
Clock to Pin 22	T_{MULTCK_P22}	-	2.14	ns
Clock to Pin 21	T_{MULTCK_P21}	-	2.02	ns
Clock to Pin 20	T_{MULTCK_P20}	-	1.89	ns
Clock to Pin 19	T_{MULTCK_P19}	-	1.77	ns
Clock to Pin 18	T_{MULTCK_P18}	-	1.65	ns
Clock to Pin 17	T_{MULTCK_P17}	-	1.52	ns
Clock to Pin 16	T_{MULTCK_P16}	-	1.40	ns
Clock to Pin 15	T_{MULTCK_P15}	-	1.28	ns
Clock to Pin 14	T_{MULTCK_P14}	-	1.15	ns
Clock to Pin 13	T_{MULTCK_P13}	-	1.15	ns
Clock to Pin 12	T_{MULTCK_P12}	-	1.15	ns
Clock to Pin 11	T_{MULTCK_P11}	-	1.15	ns
Clock to Pin 10	T_{MULTCK_P10}	-	1.15	ns
Clock to Pin 9	T_{MULTCK_P9}	-	1.15	ns
Clock to Pin 8	T_{MULTCK_P8}	-	1.15	ns
Clock to Pin 7	T_{MULTCK_P7}	-	1.15	ns
Clock to Pin 6	T_{MULTCK_P6}	-	1.15	ns
Clock to Pin 5	T_{MULTCK_P5}	-	1.15	ns
Clock to Pin 4	T_{MULTCK_P4}	-	1.15	ns
Clock to Pin 3	T_{MULTCK_P3}	-	1.15	ns
Clock to Pin 2	T_{MULTCK_P2}	-	1.15	ns
Clock to Pin 1	T_{MULTCK_P1}	-	1.15	ns
Clock to Pin 0	T_{MULTCK_P0}	-	1.15	ns

Block SelectRAM Switching Characteristics

Table 54: Block SelectRAM Switching Characteristics

Description	Symbol	Min	Min	Units
Sequential Delays				
Clock CLK to DOUT output	T_{BCKO}	-	2.65	ns
Setup and Hold Times Before Clock CLK				
ADDR inputs	T_{BACK}/T_{BCKA}	0.36/ 0.00	-	ns
DIN inputs	T_{BDCK}/T_{BCKD}	0.36/ 0.00	-	ns
EN input	T_{BECK}/T_{BCKE}	1.20/-0.58	-	ns
RST input	T_{BRCK}/T_{BCKR}	1.65/-0.90	-	ns
WEN input	T_{BWCK}/T_{BCKW}	0.72/-0.25	-	ns
Clock CLK				
Minimum Pulse Width, High	T_{BPWH}	1.48	-	ns
Minimum Pulse Width, Low	T_{BPWL}	1.48	-	ns

TBUF Switching Characteristics

Table 55: TBUF Switching Characteristics

Description	Symbol	Min	Max	Units
Combinatorial Delays				
IN input to OUT output	T_{IO}	-	0.58	ns
TRI input to OUT output high-impedance	T_{OFF}	-	0.55	ns
TRI input to valid data on OUT output	T_{ON}	-	0.55	ns

JTAG Test Access Port Switching Characteristics

Table 56: JTAG Test Access Port Switching Characteristics

Description	Symbol	Min	Max	Units
TMS and TDI Setup times before TCK	T_{TAPTK}	5.5	-	ns
TMS and TDI Hold times after TCK	T_{TCKTAP}	0.0	-	ns
Output delay from clock TCK to output TDO	T_{TCKTDO}	-	10.0	ns
Maximum TCK clock frequency	F_{TCK}	-	33	MHz

QPro Virtex-II Pin-to-Pin Output Parameter Guidelines

All devices are 100% functionally tested. Listed below are representative values for typical pin locations and normal clock loading. Values are expressed in nanoseconds unless otherwise noted.

Global Clock Input to Output Delay for LVTTTL, 12 mA, Fast Slew Rate, *with* DCM

Table 57: Global Clock Input to Output Delay for LVTTTL, 12 mA, Fast Slew Rate, with DCM

Description	Symbol	Device	Value	Units
LVTTTL Global Clock Input to Output delay using Output flip-flop, 12 mA, Fast Slew Rate, <i>with</i> DCM. For data <i>output</i> with different standards, adjust the delays with the values shown in IOB Output Switching Characteristics Standard Adjustments , page 56.				
Global Clock and OFF with DCM	T _{ICKOFDCM}	XQ2V1000	2.76	ns
		XQ2V3000	2.88	ns
		XQ2V6000	3.45	ns

Notes:

- Listed above are representative values where one global clock input drives one vertical clock line in each accessible column, and where all accessible IOB and CLB flip-flops are clocked by the global clock net.
- Output timing is measured with a 35 pF external capacitive load. The only time it is not 50% of V_{CC} threshold is with LVCMOS. For other I/O standards and different loads, see [Table 47](#).
- DCM output jitter is included in the measurement.

Global Clock Input to Output Delay for LVTTTL, 12 mA, Fast Slew Rate, *without* DCM

Table 58: Global Clock Input to Output Delay for LVTTTL, 12 mA, Fast Slew Rate, without DCM

Description	Symbol	Device	Value	Units
LVTTTL Global Clock Input to Output Delay using Output flip-flop, 12 mA, Fast Slew Rate, <i>without</i> DCM. For data <i>output</i> with different standards, adjust the delays with the values shown in IOB Output Switching Characteristics Standard Adjustments , page 56.				
Global Clock and OFF without DCM	T _{ICKOF}	XQ2V1000	5.90	ns
		XQ2V3000	6.62	ns
		XQ2V6000	7.22	ns

Notes:

- Listed above are representative values where one global clock input drives one vertical clock line in each accessible column, and where all accessible IOB and CLB flip-flops are clocked by the global clock net.
- Output timing is measured at 50% V_{CC} threshold with 35 pF external capacitive load. For other I/O standards and different loads, see [Table 47](#).

QPro Virtex-II Pin-to-Pin Input Parameter Guidelines

All devices are 100% functionally tested. Listed below are representative values for typical pin locations and normal clock loading. Values are expressed in nanoseconds unless otherwise noted.

Global Clock Setup and Hold for LVTTTL Standard, *with* DCM

Table 59: Global Clock Setup and Hold for LVTTTL Standard, *with* DCM

Description	Symbol	Device	Value	Units
Input Setup and Hold Time Relative to Global Clock Input Signal for LVTTTL Standard. For data input with different standards, adjust the setup time delay by the values shown in IOB Input Switching Characteristics Standard Adjustments , page 53.				
No Delay Global Clock and IFF with DCM	T_{PSDCM}/T_{PHDCM}	XQ2V1000	1.84/–0.76	ns
		XQ2V3000	1.96/–0.76	ns
		XQ2V6000	1.96/–0.76	ns

Notes:

1. IFF = Input Flip-Flop or Latch
2. Setup time is measured relative to the Global Clock input signal with the fastest route and the lightest load. Hold time is measured relative to the Global Clock input signal with the slowest route and heaviest load.

Global Clock Setup and Hold for LVTTTL Standard, *without* DCM

Table 60: Global Clock Setup and Hold for LVTTTL Standard, *without* DCM

Description	Symbol	Device	Value	Units
Input Setup and Hold Time Relative to Global Clock Input Signal for LVTTTL Standard. ⁽¹⁾ For data input with different standards, adjust the setup time delay by the values shown in IOB Input Switching Characteristics Standard Adjustments , page 53.				
Full Delay Global Clock and IFF ⁽²⁾ without DCM	T_{PSFD}/T_{PHFD}	XQ2V1000	2.21/ 0.00	ns
		XQ2V3000	2.21/ 0.00	ns
		XQ2V6000	2.21/ 0.50	ns

Notes:

1. Setup time is measured relative to the Global Clock input signal with the fastest route and the lightest load. Hold time is measured relative to the Global Clock input signal with the slowest route and heaviest load.
2. IFF = Input Flip-Flop or Latch
3. These values are parametrically measured.

DCM Timing Parameters

All devices are 100% functionally tested. Because of the difficulty in directly measuring many internal timing parameters, those parameters are derived from benchmark timing patterns. The following guidelines reflect worst-case values

across the recommended operating conditions. All output jitter and phase specifications are determined through statistical measurement at the package pins.

Operating Frequency Ranges

Table 61: Operating Frequency Ranges

Description	Symbol	Constraints	Value	Units
Output Clocks (Low Frequency Mode)				
CLK0, CLK90, CLK180, CLK270	CLKOUT_FREQ_1X_LF_Min		24.00	MHz
	CLKOUT_FREQ_1X_LF_Max		180.00	MHz
CLK2X, CLK2X180	CLKOUT_FREQ_2X_LF_Min		48.00	MHz
	CLKOUT_FREQ_2X_LF_Max		360.00	MHz
CLKDV	CLKOUT_FREQ_DV_LF_Min		1.50	MHz
	CLKOUT_FREQ_DV_LF_Max		120.00	MHz
CLKFX, CLKFX180	CLKOUT_FREQ_FX_LF_Min		24.00	MHz
	CLKOUT_FREQ_FX_LF_Max		210.00	MHz
Input Clocks (Low Frequency Mode)				
CLKIN (using DLL outputs) ^{(1), (3)}	CLKIN_FREQ_DLL_LF_Min		24.00	MHz
	CLKIN_FREQ_DLL_LF_Max		180.00	MHz
CLKIN (using CLKFX outputs) ^{(2), (3)}	CLKIN_FREQ_FX_LF_Min		1.00	MHz
	CLKIN_FREQ_FX_LF_Max		210.00	MHz
PSCLK	PSCLK_FREQ_LF_Min		0.01	MHz
	PSCLK_FREQ_LF_Max		360.00	MHz
Output Clocks (High Frequency Mode)				
CLK0, CLK180	CLKOUT_FREQ_1X_HF_Min		48.00	MHz
	CLKOUT_FREQ_1X_HF_Max		360.00	MHz
CLKDV	CLKOUT_FREQ_DV_HF_Min		3.00	MHz
	CLKOUT_FREQ_DV_HF_Max		240.00	MHz
CLKFX, CLKFX180	CLKOUT_FREQ_FX_HF_Min		210.00	MHz
	CLKOUT_FREQ_FX_HF_Max		270.00	MHz
Input Clocks (High Frequency Mode)				
CLKIN (using DLL outputs) ^{(1), (3)}	CLKIN_FREQ_DLL_HF_Min		48.00	MHz
	CLKIN_FREQ_DLL_HF_Max		360.00	MHz
CLKIN (using CLKFX outputs) ^{(2), (3)}	CLKIN_FRQ_FX_HF_Min		50.00	MHz
	CLKIN_FRQ_FX_HF_Max		270.00	MHz
PSCLK	PSCLK_FREQ_HF_Min		0.01	MHz
	PSCLK_FREQ_HF_Max		360.00	MHz

Notes:

1. "DLL outputs" is used here to describe the outputs: CLK0, CLK90, CLK180, CLK270, CLK2X, CLK2X180, and CLKDV.
2. If both DLL and CLKFX outputs are used, follow the more restrictive specification.
3. If the CLKIN_DIVIDE_BY_2 attribute of the DCM is used, then double these values.

Input Clock Tolerances

Table 62: Input Clock Tolerances

Description	Symbol	Constraints F _{CLKIN}	Min	Max	Units
Input Clock Low/High Pulse Width					
PSCLK	PSCLK_PULSE	< 1MHz	25.00		ns
PSCLK and CLKIN ⁽²⁾	PSCLK_PULSE and CLKIN_PULSE	1 – 10 MHz	25.00		ns
		10 – 25 MHz	10.00		ns
		25 – 50 MHz	5.00		ns
		50 – 100 MHz	3.00		ns
		100 – 150 MHz	2.40		ns
		150 – 200 MHz	2.00		ns
		200 – 250 MHz	1.80		ns
		250 – 300 MHz	1.50		ns
		300 – 350 MHz	1.30		ns
		350 – 400 MHz	1.15		ns
> 400 MHz	1.05		ns		
Input Clock Cycle-Cycle Jitter (Low Frequency Mode)					
CLKIN (using DLL outputs) ⁽¹⁾	CLKIN_CYC_JITT_DLL_LF			±300	ps
CLKIN (using CLKFX outputs) ⁽²⁾	CLKIN_CYC_JITT_FX_LF			±300	ps
Input Clock Cycle-Cycle Jitter (High Frequency Mode)					
CLKIN (using DLL outputs) ⁽¹⁾	CLKIN_CYC_JITT_DLL_HF			±150	ps
CLKIN (using CLKFX outputs) ⁽²⁾	CLKIN_CYC_JITT_FX_HF			±150	ps
Input Clock Period Jitter (Low Frequency Mode)					
CLKIN (using DLL outputs) ⁽¹⁾	CLKIN_PER_JITT_DLL_LF			±1	ns
CLKIN (using CLKFX outputs) ⁽²⁾	CLKIN_PER_JITT_FX_LF			±1	ns
Input Clock Period Jitter (High Frequency Mode)					
CLKIN (using DLL outputs) ⁽¹⁾	CLKIN_PER_JITT_DLL_HF			±1	ns
CLKIN (using CLKFX outputs) ⁽²⁾	CLKIN_PER_JITT_FX_HF			±1	ns
Feedback Clock Path Delay Variation					
CLKFB off-chip feedback	CLKFB_DELAY_VAR_EXT			±1	ns

Notes:

- “DLL outputs” is used here to describe the outputs: CLK0, CLK90, CLK180, CLK270, CLK2X, CLK2X180, and CLKDV.
- If both DLL and CLKFX outputs are used, follow the more restrictive specification.
- If the DCM phase shift feature is used and the CLKIN frequency > 200 MHz, the CLKIN duty cycle must be within ±5% (45/55 to 55/45).

Output Clock Jitter

Table 63: Output Clock Jitter

Description	Symbol	Constraints	Value	Units
Clock Synthesis Period Jitter				
CLK0	CLKOUT_PER_JITT_0		±100	ps
CLK90	CLKOUT_PER_JITT_90		±150	ps
CLK180	CLKOUT_PER_JITT_180		±150	ps
CLK270	CLKOUT_PER_JITT_270		±150	ps
CLK2X, CLK2X180	CLKOUT_PER_JITT_2X		±200	ps
CLKDV (integer division)	CLKOUT_PER_JITT_DV1		±150	ps
CLKDV (non-integer division)	CLKOUT_PER_JITT_DV2		±300	ps
CLKFX, CLKFX180	CLKOUT_PER_JITT_FX		Note 1	ps

Notes:

1. Values for this parameter are available at <http://www.xilinx.com>.

Output Clock Phase Alignment

Table 64: Output Clock Phase Alignment

Description	Symbol	Constraints	Value	Units
Phase Offset Between CLKIN and CLKFB				
CLKIN/CLKFB	CLKIN_CLKFB_PHASE		±50	ps
Phase Offset Between Any DCM Outputs				
All CLK* outputs	CLKOUT_PHASE		±140	ps
Duty Cycle Precision				
DLL outputs ⁽¹⁾	CLKOUT_DUTY_CYCLE_DLL ⁽²⁾		±150	ps
CLKFX outputs	CLKOUT_DUTY_CYCLE_FX		±100	ps

Notes:

1. "DLL outputs" is used here to describe the outputs: CLK0, CLK90, CLK180, CLK270, CLK2X, CLK2X180, and CLKDV.
2. CLKOUT_DUTY_CYCLE_DLL applies to the 1X clock outputs (CLK0, CLK90, CLK180, and CLK270) only if DUTY_CYCLE_CORRECTION = TRUE.
3. Specification also applies to PSCLK.

Miscellaneous Timing Parameters

Table 65: Miscellaneous Timing Parameters

Description	Symbol	Constraints F _{CLKIN}	Value	Units
Time Required to Achieve LOCK				
Using DLL outputs ⁽¹⁾	LOCK_DLL			
	LOCK_DLL_60	> 60MHz	20.0	μs
	LOCK_DLL_50_60	50 - 60 MHz	25.0	μs
	LOCK_DLL_40_50	40 - 50 MHz	50.0	μs
	LOCK_DLL_30_40	30 - 40 MHz	90.0	μs
	LOCK_DLL_24_30	24 - 30 MHz	120.0	μs
Using CLKFX outputs	LOCK_FX_MIN		10.0	ms
	LOCK_FX_MAX		10.0	ms
Additional lock time with fine-phase shifting	LOCK_DLL_FINE_SHIFT		50.0	μs
Fine-Phase Shifting				
Absolute shifting range	FINE_SHIFT_RANGE		10.0	ns
Delay Lines				
Tap delay resolution	DCM_TAP_MIN		30.0	ps
	DCM_TAP_MAX		60.0	ps

Notes:

- ⁽¹⁾ "DLL outputs" is used here to describe the outputs: CLK0, CLK90, CLK180, CLK270, CLK2X, CLK2X180, and CLKDV.
- Specification also applies to PSCLK.

Frequency Synthesis

Table 66: Frequency Synthesis

Attribute	Min	Max
CLKFX_MULTIPLY	2	32
CLKFX_DIVIDE	1	32

Parameter Cross Reference

Table 67: Parameter Cross Reference

Libraries Guide	Data Sheet
DLL_CLKOUT_{MIN MAX}_LF	CLKOUT_FREQ_{1X 2X DV}_LF
DFS_CLKOUT_{MIN MAX}_LF	CLKOUT_FREQ_FX_LF
DLL_CLKIN_{MIN MAX}_LF	CLKIN_FREQ_DLL_LF
DFS_CLKIN_{MIN MAX}_LF	CLKIN_FREQ_FX_LF
DLL_CLKOUT_{MIN MAX}_HF	CLKOUT_FREQ_{1X DV}_HF
DFS_CLKOUT_{MIN MAX}_HF	CLKOUT_FREQ_FX_HF
DLL_CLKIN_{MIN MAX}_HF	CLKIN_FREQ_DLL_HF
DFS_CLKIN_{MIN MAX}_HF	CLKIN_FREQ_FX_HF

Source-Synchronous Switching Characteristics

The parameters in this section provide the necessary values for calculating timing budgets for QPro Virtex-II source-synchronous transmitter and receiver data-valid windows.

Table 68: Duty Cycle Distortion and Clock-Tree Skew

Description	Symbol	Device	Value	Units
Duty Cycle Distortion ⁽¹⁾	T _{DCD_CLK0}	All	140	ps
	T _{DCD_CLK180}	All	50	ps
Clock Tree Skew ⁽²⁾	T _{CKSKEW}	XQ2V1000	90	ps
		XQ2V3000	110	ps
		XQ2V6000	550	ps

Notes:

- These parameters represent the worst-case duty cycle distortion observable at the pins of the device using LVDS output buffers. For cases where other I/O standards are used, IBIS can be used to calculate any additional duty cycle distortion that might be caused by asymmetrical rise/fall times.
T_{DCD_CLK0} applies to cases where local (IOB) inversion is used to provide the negative-edge clock to the DDR element in the I/O. T_{DCD_CLK180} applies to cases where the CLK180 output of the DCM is used to provide the negative-edge clock to the DDR element in the I/O.
- This value represents the worst-case clock-tree skew observable between sequential I/O elements. Significantly less clock-tree skew exists for I/O registers that are close to each other and fed by the same or adjacent clock-tree branches. Use the Xilinx FPGA_Editor and Timing Analyzer tools to evaluate clock skew specific to your application.

Table 69: Package Skew

Description	Symbol	Device/Package	Value	Units
Package Skew ⁽¹⁾	T _{PKGSKEW}	XQ2V6000/CF1144	90	ps

Notes:

- These values represent the worst-case skew between any two balls of the package: shortest flight time to longest flight time from Pad to Ball (7.1ps per mm).
- Package trace length information is available for these device/package combinations. This information can be used to deskew the package.

Table 70: Sample Window

Description	Symbol	Device	Value	Units
Sampling Error at Receiver Pins ⁽¹⁾	T _{SAMP}	XQ2V1000	TBD	ps
		XQ2V3000	TBD	ps
		XQ2V6000	TBD	ps

Notes:

- This parameter indicates the total sampling error of QPro Virtex-II DDR input registers across voltage, temperature, and process. The characterization methodology uses the DCM to capture the DDR input registers' edges of operation. These measurements include:
 - CLK0 and CLK180 DCM jitter
 - Worst-case Duty-Cycle Distortion - T_{DCD_CLK180}
 - DCM accuracy (phase offset)
 - DCM phase shift resolution.
 These measurements do not include package or clock tree skew.

Table 71: Pin-to-Pin Setup/Hold: Source-Synchronous Configuration

Description	Symbol	Device	Value	Units
Data Input Set-Up and Hold Times Relative to a Forwarded Clock Input Pin, Using DCM and Global Clock Buffer. For situations where clock and data inputs conform to different standards, adjust the setup and hold values accordingly using the values shown in IOB Input Switching Characteristics Standard Adjustments , page 53.				
No Delay	T_{PSDCM}/T_{PHDCM}	XQ2V1000	TBD	ns
Global Clock and IFF with DCM		XQ2V3000	TBD	ns
		XQ2V6000	TBD	ns

Notes:

1. IFF = Input Flip-Flop
2. The timing values were measured using the fine-phase adjustment feature of the DCM.
3. The worst-case duty-cycle distortion and DCM jitter on CLK0 and CLK180 is included in these measurements.

Source Synchronous Timing Budgets

This section describes how to use the parameters provided in the **Source-Synchronous Switching Characteristics** section to develop system-specific timing budgets. The following analysis provides information necessary for deter-

mining QPro Virtex-II contributions to an overall system timing analysis. No assumptions are made about the effects of Inter-Symbol Interference or PCB skew.

QPro Virtex-II Transmitter Data-Valid Window (T_X)

T_X is the minimum aggregate valid data period for a source-synchronous data bus at the pins of the device and is calculated as follows:

$$T_X = \text{Data Period} - [\text{Jitter}^{(1)} + \text{Duty Cycle Distortion}^{(2)} + \text{TCKSKEW}^{(3)} + \text{TPKGSKEW}^{(4)}]$$

Notes:

1. Jitter values and accumulation methodology to be provided in a future release of this document. The absolute period jitter values found in the **DCM Timing Parameters** section of the particular DCM output clock used to clock the IOB FF can be used for a best-case analysis.
2. This value depends on the clocking methodology used. See Note 1 for Table 68.
3. This value represents the worst-case clock-tree skew observable between sequential I/O elements. Significantly less clock-tree skew exists for I/O registers that are close to each other and fed by the same or adjacent clock-tree branches. Use the Xilinx FPGA_Editor and Timing Analyzer tools to evaluate clock skew specific to your application.
4. These values represent the worst-case skew between any two balls of the package: shortest flight time to longest flight time from Pad to Ball.

QPro Virtex-II Receiver Data-Valid Window (R_X)

R_X is the required minimum aggregate valid data period for a source-synchronous data bus at the pins of the device and is calculated as follows:

$$R_X = [\text{TSAMP}^{(1)} + \text{TCKSKEW}^{(2)} + \text{TPKGSKEW}^{(3)}]$$

Notes:

1. This parameter indicates the total sampling error of QPro Virtex-II DDR input registers across voltage, temperature, and process. The characterization methodology uses the DCM to capture the DDR input registers' edges of operation. These measurements include:
 - CLK0 and CLK180 DCM jitter in a quiet system
 - Worst-case duty-cycle distortion
 - DCM accuracy (phase offset)
 - DCM phase shift resolution
 These measurements do not include package or clock tree skew.
2. This value represents the worst-case clock-tree skew observable between sequential I/O elements. Significantly less clock-tree skew exists for I/O registers that are close to each other and fed by the same or adjacent clock-tree branches. Use the Xilinx FPGA_Editor and Timing Analyzer tools to evaluate clock skew specific to your application.
3. These values represent the worst-case skew between any two balls of the package: shortest flight time to longest flight time from Pad to Ball.

QPro Virtex-II Device/Package Combinations and Maximum I/Os Available

This section provides **QPro Virtex-II Device/Package Combinations and Maximum I/Os Available** and **QPro Virtex-II Pin Definitions**, followed by pinout tables for the following packages:

- **FG456 Fine-Pitch BGA Package**
- **BG575 Standard BGA Package**
- **BG728 Standard BGA and CG717 Ceramic CGA Packages**
- **CF1144 Ceramic Flip-Chip Fine-Pitch CGA Package**

QPro Virtex-II devices are available in both wire-bond and flip-chip packages. The basic package dimensions are listed in [Table 72](#). See [Figure 52](#) through [Figure 56](#) for a more complete mechanical description of each available package. [Table 73](#) shows the maximum number of user I/Os

possible for each available package. There are four package type definitions:

- FG denotes plastic wire-bond fine-pitch BGA (1.00 mm pitch).
- BG denotes plastic wire-bond ball grid array (1.27 mm pitch).
- CG denotes hermetic ceramic wire-bond column grid array (1.27 mm pitch).
- CF denotes non-hermetic ceramic flip-chip column grid array (1.00 mm pitch).

The number of I/Os per package include all user I/Os except the 15 control pins (CCLK, DONE, M0, M1, M2, PROG_B, PWRDWN_B, TCK, TDI, TDO, TMS, HSWAP_EN, DXN, DXP, AND RSVD).

Table 72: Package Information

Package	FG456	BG575	BG728 & CG717	CF1144
Pitch (mm)	1.00	1.27	1.27	1.00
Size (mm)	23 x 23	31 x 31	35 x 35	35 x 35

Table 73: QPro Virtex-II Device/Package Combinations and Maximum Number of Available I/Os (Advance Information)

Package	Available I/Os		
	XQ2V1000	XQ2V3000	XQ2V6000
FG456	324	-	-
BG575	328	-	-
BG728	-	516	-
CG717	-	516	-
CF1144	-	-	824

Notes:

1. The BG728 and CG717 packages are pinout (footprint) compatible.

QPro Virtex-II Pin Definitions

This section describes the pinouts for QPro Virtex-II devices in the following packages:

- FG456: wire-bond fine-pitch BGA of 1.00 mm pitch
- BG575 and BG728: wire-bond BGA of 1.27 mm pitch
- CG717: wire-bond ceramic column grid of 1.27 mm pitch
- CF1144: Ceramic flip-chip fine-pitch column grid of 1.00 mm pitch

Each device is split into eight I/O banks to allow for flexibility in the choice of I/O standards (see the *QPro Virtex-II Data Sheet*). Global pins, including JTAG, configuration, and power/ground pins, are listed at the end of each table. [Table 74](#) provides definitions for all pin types.

All QPro Virtex-II pinout tables are available on the distribution CD-ROM, or on the web (at <http://www.xilinx.com>).

Pin Definitions

Table 74 provides a description of each pin type listed in QPro Virtex-II pinout tables.

Table 74: QPro Virtex-II Pin Definitions

Pin Name	Direction	Description
User I/O Pins		
IO_LXXY_#	Input/Output	All user I/O pins are capable of differential signalling and can implement LVDS, ULVDS, BLVDS, LVPECL, or LDT pairs. Each user I/O is labeled "IO_LXXY_#", where: <ul style="list-style-type: none"> IO indicates a user I/O pin. LXXY indicates a differential pair, with XX a unique pair in the bank and Y = P/N for the positive and negative sides of the differential pair. # indicates the bank number (0 through 7).
Dual-Function Pins		
IO_LXXY_#/ZZZ		The dual-function pins are labelled "IO_LXXY_#/ZZZ", where ZZZ can be one of the following pins: Per Bank - VRP, VRN, or VREF Globally - GCLKX(S/P), BUSY/DOUT, INIT_B, DIN/D0 – D7, RDWR_B, or CS_B
With /ZZZ		
DIN/D0, D1, D2, D3, D4, D5, D6, D7	Input/Output	In SelectMAP mode, D0 through D7 are configuration data pins. These pins become user I/Os after configuration, unless the SelectMAP port is retained. In bit-serial modes, DIN (D0) is the single-data input. This pin becomes a user I/O after configuration.
CS_B	Input	In SelectMAP mode, this is the active-Low Chip Select signal. This pin becomes a user I/O after configuration, unless the SelectMAP port is retained.
RDWR_B	Input	In SelectMAP mode, this is the active-Low Write Enable signal. This pin becomes a user I/O after configuration, unless the SelectMAP port is retained.
BUSY/DOUT	Output	In SelectMAP mode, BUSY controls the rate at which configuration data is loaded. This pin becomes a user I/O after configuration, unless the SelectMAP port is retained. In bit-serial modes, DOUT provides preamble and configuration data to downstream devices in a daisy chain. This pin becomes a user I/O after configuration.
INIT_B	Bidirectional (open-drain)	When Low, this pin indicates that the configuration memory is being cleared. When held Low, the start of configuration is delayed. During configuration, a Low on this output indicates that a configuration data error has occurred. This pin becomes a user I/O after configuration.
GCLKx (S/P)	Input/Output	These are clock input pins that connect to Global Clock Buffers. These pins become regular user I/Os when not needed for clocks.
VRP	Input	This pin is for the DCI voltage reference resistor of the P transistor (per bank).
VRN	Input	This pin is for the DCI voltage reference resistor of the N transistor (per bank).
ALT_VRP	Input	This is the alternative pin for the DCI voltage reference resistor of the P transistor.
ALT_VRN	Input	This is the alternative pin for the DCI voltage reference resistor of the N transistor.
V _{REF}	Input	These are input threshold voltage pins. They become user I/Os when an external threshold voltage is not needed (per bank).
Dedicated Pins⁽¹⁾		
CCLK	Input/Output	Configuration clock. Output in Master mode or Input in Slave mode.

Table 74: QPro Virtex-II Pin Definitions (Continued)

Pin Name	Direction	Description
PROG_B	Input	Active Low asynchronous reset to configuration logic. This pin has a permanent weak pull-up resistor.
DONE	Input/Output	DONE is a bidirectional signal with an optional internal pull-up resistor. As an output, this pin indicates completion of the configuration process. As an input, a Low level on DONE can be configured to delay the start-up sequence.
M2, M1, M0	Input	Configuration mode selection.
HSWAP_EN	Input	Enable I/O pullups during configuration.
TCK	Input	Boundary Scan Clock.
TDI	Input	Boundary Scan Data Input.
TDO	Output	Boundary Scan Data Output.
TMS	Input	Boundary Scan Mode Select.
PWRDWN_B	Input (unsupported)	Active Low power-down pin (unsupported). <i>Driving this pin Low can adversely affect device operation and configuration.</i> PWRDWN_B is internally pulled High, which is its default state. It does not require an external pull-up.
Other Pins		
DXN, DXP	N/A	Temperature-sensing diode pins (Anode: DXP, Cathode: DXN).
V _{BATT}	Input	Decryptor key memory backup supply. (Do not connect if battery is not used.)
RSVD	N/A	Reserved pin - do not connect.
V _{CCO}	Input	Power-supply pins for the output drivers (per bank).
V _{CCAUX}	Input	Power-supply pins for auxiliary circuits.
V _{CCINT}	Input	Power-supply pins for the internal core logic.
GND	Input	Ground.

Notes:

- All dedicated pins (JTAG and configuration) are powered by V_{CCAUX} (independent of the bank V_{CCO} voltage).

FG456 Fine-Pitch BGA Package

As shown in [Table 75](#), the XQ2V1000 QPro Virtex-II device is available in the FG456 fine-pitch BGA package. Pins definitions are identical to the commercial grade

XC2V1000-FG456. Following this table are the **FG456 Fine-Pitch BGA Package Specifications (1.00mm pitch)**.

Table 75: FG456 BGA — XQ2V1000

Bank	Pin Description	Pin Number
0	IO_L01N_0	B4
0	IO_L01P_0	A4
0	IO_L02N_0	C4
0	IO_L02P_0	C5
0	IO_L03N_0/VRP_0	B5
0	IO_L03P_0/VRN_0	A5
0	IO_L04N_0/VREF_0	D6
0	IO_L04P_0	C6
0	IO_L05N_0	B6
0	IO_L05P_0	A6
0	IO_L06N_0	E7
0	IO_L06P_0	E8
0	IO_L21N_0	D7
0	IO_L21P_0/VREF_0	C7
0	IO_L22N_0	B7
0	IO_L22P_0	A7
0	IO_L24N_0	D8
0	IO_L24P_0	C8
0	IO_L49N_0	B8
0	IO_L49P_0	A8
0	IO_L51N_0	E9
0	IO_L51P_0/VREF_0	F9
0	IO_L52N_0	D9
0	IO_L52P_0	C9
0	IO_L54N_0	B9
0	IO_L54P_0	A9
0	IO_L91N_0/VREF_0	E10
0	IO_L91P_0	F10
0	IO_L92N_0	D10
0	IO_L92P_0	C10

Table 75: FG456 BGA — XQ2V1000

Bank	Pin Description	Pin Number
0	IO_L93N_0	B10
0	IO_L93P_0	A10
0	IO_L94N_0/VREF_0	E11
0	IO_L94P_0	F11
0	IO_L95N_0/GCLK7P	D11
0	IO_L95P_0/GCLK6S	C11
0	IO_L96N_0/GCLK5P	B11
0	IO_L96P_0/GCLK4S	A11
1	IO_L96N_1/GCLK3P	F12
1	IO_L96P_1/GCLK2S	F13
1	IO_L95N_1/GCLK1P	E12
1	IO_L95P_1/GCLK0S	D12
1	IO_L94N_1	C12
1	IO_L94P_1/VREF_1	B12
1	IO_L93N_1	A13
1	IO_L93P_1	B13
1	IO_L92N_1	C13
1	IO_L92P_1	D13
1	IO_L91N_1	E13
1	IO_L91P_1/VREF_1	E14
1	IO_L54N_1	A14
1	IO_L54P_1	B14
1	IO_L52N_1	C14
1	IO_L52P_1	D14
1	IO_L51N_1/VREF_1	A15
1	IO_L51P_1	B15
1	IO_L49N_1	C15
1	IO_L49P_1	D15
1	IO_L24N_1	F14

Table 75: FG456 BGA — XQ2V1000

Bank	Pin Description	Pin Number
1	IO_L24P_1	E15
1	IO_L22N_1	A16
1	IO_L22P_1	B16
1	IO_L21N_1/VREF_1	C16
1	IO_L21P_1	D16
1	IO_L06N_1	E16
1	IO_L06P_1	E17
1	IO_L05N_1	A17
1	IO_L05P_1	B17
1	IO_L04N_1	C17
1	IO_L04P_1/VREF_1	D17
1	IO_L03N_1/VRP_1	A18
1	IO_L03P_1/VRN_1	B18
1	IO_L02N_1	C18
1	IO_L02P_1	D18
1	IO_L01N_1	A19
1	IO_L01P_1	B19
2	IO_L01N_2	C21
2	IO_L01P_2	C22
2	IO_L02N_2/VRP_2	E18
2	IO_L02P_2/VRN_2	F18
2	IO_L03N_2	D21
2	IO_L03P_2/VREF_2	D22
2	IO_L04N_2	E19
2	IO_L04P_2	E20
2	IO_L06N_2	E21
2	IO_L06P_2	E22
2	IO_L19N_2	F19
2	IO_L19P_2	F20
2	IO_L21N_2	F21
2	IO_L21P_2/VREF_2	F22
2	IO_L22N_2	G18
2	IO_L22P_2	H18
2	IO_L24N_2	G19

Table 75: FG456 BGA — XQ2V1000

Bank	Pin Description	Pin Number
2	IO_L24P_2	G20
2	IO_L43N_2	G21
2	IO_L43P_2	G22
2	IO_L45N_2	H19
2	IO_L45P_2/VREF_2	H20
2	IO_L46N_2	H21
2	IO_L46P_2	H22
2	IO_L48N_2	J17
2	IO_L48P_2	J18
2	IO_L49N_2	J19
2	IO_L49P_2	J20
2	IO_L51N_2	J21
2	IO_L51P_2/VREF_2	J22
2	IO_L52N_2	K17
2	IO_L52P_2	K18
2	IO_L54N_2	K19
2	IO_L54P_2	K20
2	IO_L91N_2	K21
2	IO_L91P_2	K22
2	IO_L93N_2	L17
2	IO_L93P_2/VREF_2	L18
2	IO_L94N_2	L19
2	IO_L94P_2	L20
2	IO_L96N_2	L21
2	IO_L96P_2	L22
3	IO_L96N_3	M21
3	IO_L96P_3	M20
3	IO_L94N_3	M19
3	IO_L94P_3	M18
3	IO_L93N_3/VREF_3	M17
3	IO_L93P_3	N17
3	IO_L91N_3	N22
3	IO_L91P_3	N21
3	IO_L54N_3	N20

Table 75: FG456 BGA — XQ2V1000

Bank	Pin Description	Pin Number
3	IO_L54P_3	N19
3	IO_L52N_3	N18
3	IO_L52P_3	P18
3	IO_L51N_3/VREF_3	P22
3	IO_L51P_3	P21
3	IO_L49N_3	P20
3	IO_L49P_3	P19
3	IO_L48N_3	R22
3	IO_L48P_3	R21
3	IO_L46N_3	R20
3	IO_L46P_3	R19
3	IO_L45N_3/VREF_3	R18
3	IO_L45P_3	P17
3	IO_L43N_3	T22
3	IO_L43P_3	T21
3	IO_L24N_3	T20
3	IO_L24P_3	T19
3	IO_L22N_3	U22
3	IO_L22P_3	U21
3	IO_L21N_3/VREF_3	U20
3	IO_L21P_3	U19
3	IO_L19N_3	T18
3	IO_L19P_3	U18
3	IO_L06N_3	V22
3	IO_L06P_3	V21
3	IO_L04N_3	V20
3	IO_L04P_3	V19
3	IO_L03N_3/VREF_3	W22
3	IO_L03P_3	W21
3	IO_L02N_3/VRP_3	Y22
3	IO_L02P_3/VRN_3	Y21
3	IO_L01N_3	W20
3	IO_L01P_3	AA20
4	IO_L01N_4/DOUT	AB19

Table 75: FG456 BGA — XQ2V1000

Bank	Pin Description	Pin Number
4	IO_L01P_4/INIT_B	AA19
4	IO_L02N_4/D0	V18
4	IO_L02P_4/D1	V17
4	IO_L03N_4/D2/ALT_VRP_4	W18
4	IO_L03P_4/D3/ALT_VRN_4	Y18
4	IO_L04N_4/VREF_4	AA18
4	IO_L04P_4	AB18
4	IO_L05N_4/VRP_4	W17
4	IO_L05P_4/VRN_4	Y17
4	IO_L06N_4	AA17
4	IO_L06P_4	AB17
4	IO_L19N_4	V16
4	IO_L19P_4	V15
4	IO_L21N_4	W16
4	IO_L21P_4/VREF_4	Y16
4	IO_L22N_4	AA16
4	IO_L22P_4	AB16
4	IO_L24N_4	W15
4	IO_L24P_4	Y15
4	IO_L49N_4	AA15
4	IO_L49P_4	AB15
4	IO_L51N_4	U14
4	IO_L51P_4/VREF_4	V14
4	IO_L52N_4	W14
4	IO_L52P_4	Y14
4	IO_L54N_4	AA14
4	IO_L54P_4	AB14
4	IO_L91N_4/VREF_4	U13
4	IO_L91P_4	V13
4	IO_L92N_4	W13
4	IO_L92P_4	Y13
4	IO_L93N_4	AA13
4	IO_L93P_4	AB13
4	IO_L94N_4/VREF_4	U12
4	IO_L94P_4	V12

Table 75: FG456 BGA — XQ2V1000

Bank	Pin Description	Pin Number
4	IO_L95N_4/GCLK3S	W12
4	IO_L95P_4/GCLK2P	Y12
4	IO_L96N_4/GCLK1S	AA12
4	IO_L96P_4/GCLK0P	AB12
5	IO_L96N_5/GCLK7S	AA11
5	IO_L96P_5/GCLK6P	Y11
5	IO_L95N_5/GCLK5S	W11
5	IO_L95P_5/GCLK4P	V11
5	IO_L94N_5	U11
5	IO_L94P_5/VREF_5	U10
5	IO_L93N_5	AB10
5	IO_L93P_5	AA10
5	IO_L92N_5	Y10
5	IO_L92P_5	W10
5	IO_L91N_5	V10
5	IO_L91P_5/VREF_5	V9
5	IO_L54N_5	AB9
5	IO_L54P_5	AA9
5	IO_L52N_5	Y9
5	IO_L52P_5	W9
5	IO_L51N_5/VREF_5	AB8
5	IO_L51P_5	AA8
5	IO_L49N_5	Y8
5	IO_L49P_5	W8
5	IO_L24N_5	U9
5	IO_L24P_5	V8
5	IO_L22N_5	AB7
5	IO_L22P_5	AA7
5	IO_L21N_5/VREF_5	Y7
5	IO_L21P_5	W7
5	IO_L19N_5	AB6
5	IO_L19P_5	AA6
5	IO_L06N_5	Y6
5	IO_L06P_5	W6

Table 75: FG456 BGA — XQ2V1000

Bank	Pin Description	Pin Number
5	IO_L05N_5/VRP_5	V7
5	IO_L05P_5/VRN_5	V6
5	IO_L04N_5	AB5
5	IO_L04P_5/VREF_5	AA5
5	IO_L03N_5/D4/ALT_VRP_5	Y5
5	IO_L03P_5/D5/ALT_VRN_5	W5
5	IO_L02N_5/D6	AB4
5	IO_L02P_5/D7	AA4
5	IO_L01N_5/RDWR_B	Y4
5	IO_L01P_5/CS_B	AA3
6	IO_L01P_6	V5
6	IO_L01N_6	U5
6	IO_L02P_6/VRN_6	Y2
6	IO_L02N_6/VRP_6	Y1
6	IO_L03P_6	V4
6	IO_L03N_6/VREF_6	V3
6	IO_L04P_6	W2
6	IO_L04N_6	W1
6	IO_L06P_6	U4
6	IO_L06N_6	U3
6	IO_L19P_6	V2
6	IO_L19N_6	V1
6	IO_L21P_6	U2
6	IO_L21N_6/VREF_6	U1
6	IO_L22P_6	T5
6	IO_L22N_6	R5
6	IO_L24P_6	T4
6	IO_L24N_6	T3
6	IO_L43P_6	T2
6	IO_L43N_6	T1
6	IO_L45P_6	R4
6	IO_L45N_6/VREF_6	R3
6	IO_L46P_6	R2
6	IO_L46N_6	R1

Table 75: FG456 BGA — XQ2V1000

Bank	Pin Description	Pin Number
6	IO_L48P_6	P6
6	IO_L48N_6	P5
6	IO_L49P_6	P4
6	IO_L49N_6	P3
6	IO_L51P_6	P2
6	IO_L51N_6/VREF_6	P1
6	IO_L52P_6	N6
6	IO_L52N_6	N5
6	IO_L54P_6	N4
6	IO_L54N_6	N3
6	IO_L91P_6	N2
6	IO_L91N_6	N1
6	IO_L93P_6	M6
6	IO_L93N_6/VREF_6	M5
6	IO_L94P_6	M4
6	IO_L94N_6	M3
6	IO_L96P_6	M2
6	IO_L96N_6	M1
7	IO_L96P_7	L2
7	IO_L96N_7	L3
7	IO_L94P_7	L4
7	IO_L94N_7	L5
7	IO_L93P_7/VREF_7	K1
7	IO_L93N_7	K2
7	IO_L91P_7	K3
7	IO_L91N_7	K4
7	IO_L54P_7	L6
7	IO_L54N_7	K6
7	IO_L52P_7	K5
7	IO_L52N_7	J5
7	IO_L51P_7/VREF_7	J1
7	IO_L51N_7	J2
7	IO_L49P_7	J3
7	IO_L49N_7	J4

Table 75: FG456 BGA — XQ2V1000

Bank	Pin Description	Pin Number
7	IO_L48P_7	H1
7	IO_L48N_7	H2
7	IO_L46P_7	H3
7	IO_L46N_7	H4
7	IO_L45P_7/VREF_7	J6
7	IO_L45N_7	H5
7	IO_L43P_7	G1
7	IO_L43N_7	G2
7	IO_L24P_7	G3
7	IO_L24N_7	G4
7	IO_L22P_7	F1
7	IO_L22N_7	F2
7	IO_L21P_7/VREF_7	F3
7	IO_L21N_7	F4
7	IO_L19P_7	G5
7	IO_L19N_7	F5
7	IO_L06P_7	E1
7	IO_L06N_7	E2
7	IO_L04P_7	E3
7	IO_L04N_7	E4
7	IO_L03P_7/VREF_7	D1
7	IO_L03N_7	D2
7	IO_L02P_7/VRN_7	C1
7	IO_L02N_7/VRP_7	C2
7	IO_L01P_7	E5
7	IO_L01N_7	E6
0	VCCO_0	G11
0	VCCO_0	G10
0	VCCO_0	G9
0	VCCO_0	F8
0	VCCO_0	F7
1	VCCO_1	G14
1	VCCO_1	G13
1	VCCO_1	G12

Table 75: FG456 BGA — XQ2V1000

Bank	Pin Description	Pin Number
1	VCCO_1	F16
1	VCCO_1	F15
2	VCCO_2	L16
2	VCCO_2	K16
2	VCCO_2	J16
2	VCCO_2	H17
2	VCCO_2	G17
3	VCCO_3	T17
3	VCCO_3	R17
3	VCCO_3	P16
3	VCCO_3	N16
3	VCCO_3	M16
4	VCCO_4	U16
4	VCCO_4	U15
4	VCCO_4	T14
4	VCCO_4	T13
4	VCCO_4	T12
5	VCCO_5	U8
5	VCCO_5	U7
5	VCCO_5	T11
5	VCCO_5	T10
5	VCCO_5	T9
6	VCCO_6	T6
6	VCCO_6	R6
6	VCCO_6	P7
6	VCCO_6	N7
6	VCCO_6	M7
7	VCCO_7	L7
7	VCCO_7	K7
7	VCCO_7	J7
7	VCCO_7	H6
7	VCCO_7	G6
NA	CCLK	Y19
NA	PROG_B	A2

Table 75: FG456 BGA — XQ2V1000

Bank	Pin Description	Pin Number
NA	DONE	AB20
NA	M0	AB2
NA	M1	W3
NA	M2	AB3
NA	HSWAP_EN	B3
NA	TCK	C19
NA	TDI	D3
NA	TDO	D20
NA	TMS	B20
NA	PWRDWN_B	AB21
NA	DXN	D5
NA	DXP	A3
NA	VBATT	A21
NA	RSVD	A20
NA	VCCAUX	AB11
NA	VCCAUX	AA22
NA	VCCAUX	AA1
NA	VCCAUX	M22
NA	VCCAUX	L1
NA	VCCAUX	B22
NA	VCCAUX	B1
NA	VCCAUX	A12
NA	VCCINT	U17
NA	VCCINT	U6
NA	VCCINT	T16
NA	VCCINT	T15
NA	VCCINT	T8
NA	VCCINT	T7
NA	VCCINT	R16
NA	VCCINT	R7
NA	VCCINT	H16
NA	VCCINT	H7
NA	VCCINT	G16
NA	VCCINT	G15

Table 75: FG456 BGA — XQ2V1000

Bank	Pin Description	Pin Number
NA	VCCINT	G8
NA	VCCINT	G7
NA	VCCINT	F17
NA	VCCINT	F6
NA	GND	AB22
NA	GND	AB1
NA	GND	AA21
NA	GND	AA2
NA	GND	Y20
NA	GND	Y3
NA	GND	W19
NA	GND	W4
NA	GND	P14
NA	GND	P13
NA	GND	P12
NA	GND	P11
NA	GND	P10
NA	GND	P9
NA	GND	N14
NA	GND	N13
NA	GND	N12
NA	GND	N11
NA	GND	N10
NA	GND	N9
NA	GND	M14
NA	GND	M13
NA	GND	M12
NA	GND	M11
NA	GND	M10
NA	GND	M9
NA	GND	L14
NA	GND	L13
NA	GND	L12
NA	GND	L11
NA	GND	L10

Table 75: FG456 BGA — XQ2V1000

Bank	Pin Description	Pin Number
NA	GND	L9
NA	GND	K14
NA	GND	K13
NA	GND	K12
NA	GND	K11
NA	GND	K10
NA	GND	K9
NA	GND	J14
NA	GND	J13
NA	GND	J12
NA	GND	J11
NA	GND	J10
NA	GND	J9
NA	GND	D19
NA	GND	D4
NA	GND	C20
NA	GND	C3
NA	GND	B21
NA	GND	B2
NA	GND	A22
NA	GND	A1

FG456 Fine-Pitch BGA Package Specifications (1.00mm pitch)

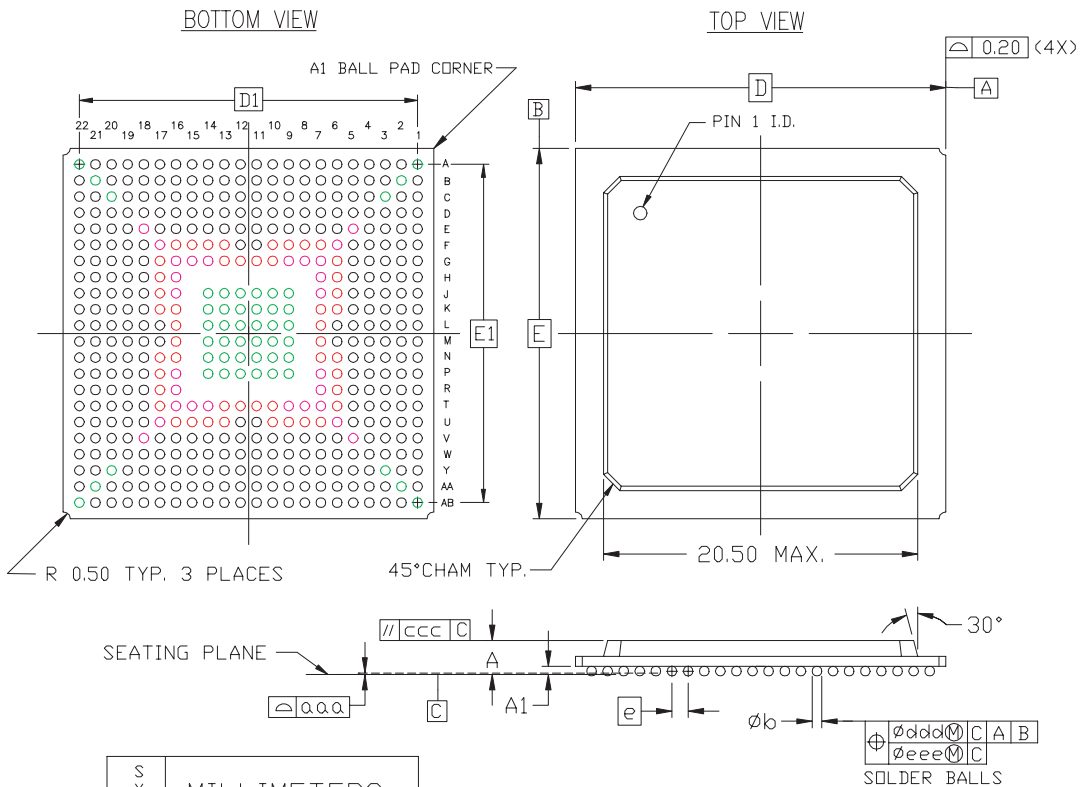

SYMBOL	MILLIMETERS		
	MIN.	NOM.	MAX.
A	$\sqrt{\text{H}}$	2.20	2.60
A ₁	0.40	0.50	0.60
D/E	23.00 BSC		
D ₁ /E ₁	21.00 REF		
e	1.00 BSC		
φ _b	0.50	0.60	0.70
aaa	$\sqrt{\text{H}}$	$\sqrt{\text{H}}$	0.20
ccc	$\sqrt{\text{H}}$	$\sqrt{\text{H}}$	0.35
ddd	$\sqrt{\text{H}}$	$\sqrt{\text{H}}$	0.30
eee	$\sqrt{\text{H}}$	$\sqrt{\text{H}}$	0.10
M	22		

NOTES:

1. ALL DIMENSIONS AND TOLERANCES CONFORM TO ANSI Y14.5M-1994
2. SYMBOL 'M' IS THE BALL MATRIX SIZE.
3. CONFORMS TO JEDEC MO-151 AAJ-1 (DEPOPULATED)

Figure 52: FG456 Fine-Pitch BGA Package Specifications

BG575 Standard BGA Package

As shown in Table 76, the XQ2V1000 QPro Virtex-II device is available in the BG575 BGA package. Following this table

are the **BG575 Standard BGA Package Specifications (1.27mm pitch)**.

Table 76: **BG575 BGA — XQ2V1000**

Bank	Pin Description	Pin Number
0	IO_L01N_0	A3
0	IO_L01P_0	A4
0	IO_L02N_0	D5
0	IO_L02P_0	C5
0	IO_L03N_0/VRP_0	E6
0	IO_L03P_0/VRN_0	D6
0	IO_L04N_0/VREF_0	F7
0	IO_L04P_0	E7
0	IO_L05N_0	G8
0	IO_L05P_0	H9
0	IO_L06N_0	A5
0	IO_L06P_0	A6
0	IO_L19N_0	B5
0	IO_L19P_0	B6
0	IO_L21N_0	D7
0	IO_L21P_0/VREF_0	C7
0	IO_L22N_0	F8
0	IO_L22P_0	E8
0	IO_L24N_0	G9
0	IO_L24P_0	F9
0	IO_L49N_0	G10
0	IO_L49P_0	H10
0	IO_L51N_0	B7
0	IO_L51P_0/VREF_0	B8
0	IO_L52N_0	D8
0	IO_L52P_0	C8
0	IO_L54N_0	E9
0	IO_L54P_0	D9
0	IO_L67N_0	A8
0	IO_L67P_0	A9
0	IO_L69N_0	C9

Table 76: **BG575 BGA — XQ2V1000**

Bank	Pin Description	Pin Number
0	IO_L69P_0/VREF_0	B9
0	IO_L70N_0	F10
0	IO_L70P_0	E10
0	IO_L72N_0	A10
0	IO_L72P_0	A11
0	IO_L73N_0	C10
0	IO_L73P_0	B10
0	IO_L91N_0/VREF_0	D11
0	IO_L91P_0	C11
0	IO_L92N_0	G11
0	IO_L92P_0	E11
0	IO_L93N_0	C12
0	IO_L93P_0	B12
0	IO_L94N_0/VREF_0	E12
0	IO_L94P_0	D12
0	IO_L95N_0/GCLK7P	G12
0	IO_L95P_0/GCLK6S	F12
0	IO_L96N_0/GCLK5P	H11
0	IO_L96P_0/GCLK4S	H12
1	IO_L96N_1/GCLK3P	A13
1	IO_L96P_1/GCLK2S	A14
1	IO_L95N_1/GCLK1P	B13
1	IO_L95P_1/GCLK0S	C13
1	IO_L94N_1	D13
1	IO_L94P_1/VREF_1	E13
1	IO_L93N_1	F13
1	IO_L93P_1	G13
1	IO_L92N_1	H13
1	IO_L92P_1	H14
1	IO_L91N_1	C14

Table 76: BG575 BGA — XQ2V1000

Bank	Pin Description	Pin Number
1	IO_L91P_1/VREF_1	D14
1	IO_L73N_1	E14
1	IO_L73P_1	G14
1	IO_L72N_1	A15
1	IO_L72P_1	A16
1	IO_L70N_1	B15
1	IO_L70P_1	C15
1	IO_L69N_1/VREF_1	E15
1	IO_L69P_1	F15
1	IO_L67N_1	G15
1	IO_L67P_1	H15
1	IO_L54N_1	B16
1	IO_L54P_1	C16
1	IO_L52N_1	D16
1	IO_L52P_1	E16
1	IO_L51N_1/VREF_1	F16
1	IO_L51P_1	G16
1	IO_L49N_1	A17
1	IO_L49P_1	A19
1	IO_L24N_1	B17
1	IO_L24P_1	B18
1	IO_L22N_1	C17
1	IO_L22P_1	D17
1	IO_L21N_1/VREF_1	F17
1	IO_L21P_1	E17
1	IO_L19N_1	A20
1	IO_L19P_1	A21
1	IO_L06N_1	B19
1	IO_L06P_1	B20
1	IO_L05N_1	C18
1	IO_L05P_1	D18
1	IO_L04N_1	C20
1	IO_L04P_1/VREF_1	D20
1	IO_L03N_1/VRP_1	D19
1	IO_L03P_1/VRN_1	E19

Table 76: BG575 BGA — XQ2V1000

Bank	Pin Description	Pin Number
1	IO_L02N_1	E18
1	IO_L02P_1	F18
1	IO_L01N_1	H16
1	IO_L01P_1	G17
2	IO_L01N_2	D22
2	IO_L01P_2	D23
2	IO_L02N_2/VRP_2	E21
2	IO_L02P_2/VRN_2	E22
2	IO_L03N_2	F21
2	IO_L03P_2/VREF_2	F20
2	IO_L04N_2	G20
2	IO_L04P_2	G19
2	IO_L06N_2	H18
2	IO_L06P_2	J17
2	IO_L19N_2	D24
2	IO_L19P_2	E23
2	IO_L21N_2	E24
2	IO_L21P_2/VREF_2	F24
2	IO_L22N_2	F23
2	IO_L22P_2	G23
2	IO_L24N_2	G21
2	IO_L24P_2	G22
2	IO_L43N_2	H19
2	IO_L43P_2	H20
2	IO_L45N_2	J18
2	IO_L45P_2/VREF_2	J19
2	IO_L46N_2	K17
2	IO_L46P_2	K18
2	IO_L48N_2	H23
2	IO_L48P_2	H24
2	IO_L49N_2	H21
2	IO_L49P_2	H22
2	IO_L51N_2	J24
2	IO_L51P_2/VREF_2	K24

Table 76: BG575 BGA — XQ2V1000

Bank	Pin Description	Pin Number
2	IO_L52N_2	J22
2	IO_L52P_2	J23
2	IO_L54N_2	J20
2	IO_L54P_2	J21
2	IO_L67N_2	K19
2	IO_L67P_2	K20
2	IO_L69N_2	L17
2	IO_L69P_2/VREF_2	L18
2	IO_L70N_2	K23
2	IO_L70P_2	L24
2	IO_L72N_2	K22
2	IO_L72P_2	L22
2	IO_L73N_2	L21
2	IO_L73P_2	L20
2	IO_L91N_2	M23
2	IO_L91P_2	N24
2	IO_L93N_2	M21
2	IO_L93P_2/VREF_2	M22
2	IO_L94N_2	M19
2	IO_L94P_2	M20
2	IO_L96N_2	M17
2	IO_L96P_2	M18
3	IO_L96N_3	N23
3	IO_L96P_3	N22
3	IO_L94N_3	N20
3	IO_L94P_3	N21
3	IO_L93N_3/VREF_3	N19
3	IO_L93P_3	N18
3	IO_L91N_3	N17
3	IO_L91P_3	P17
3	IO_L73N_3	P24
3	IO_L73P_3	R24
3	IO_L72N_3	R23
3	IO_L72P_3	R22

Table 76: BG575 BGA — XQ2V1000

Bank	Pin Description	Pin Number
3	IO_L70N_3	P22
3	IO_L70P_3	P21
3	IO_L69N_3/VREF_3	P20
3	IO_L69P_3	P18
3	IO_L67N_3	T24
3	IO_L67P_3	U24
3	IO_L54N_3	T23
3	IO_L54P_3	T22
3	IO_L52N_3	T21
3	IO_L52P_3	T20
3	IO_L51N_3/VREF_3	R20
3	IO_L51P_3	R19
3	IO_L49N_3	W24
3	IO_L49P_3	W23
3	IO_L48N_3	U23
3	IO_L48P_3	V23
3	IO_L46N_3	U22
3	IO_L46P_3	U21
3	IO_L45N_3/VREF_3	V22
3	IO_L45P_3	V21
3	IO_L43N_3	U19
3	IO_L43P_3	U20
3	IO_L24N_3	T19
3	IO_L24P_3	T18
3	IO_L22N_3	R18
3	IO_L22P_3	R17
3	IO_L21N_3/VREF_3	Y24
3	IO_L21P_3	Y23
3	IO_L19N_3	AA24
3	IO_L19P_3	AB24
3	IO_L06N_3	AA23
3	IO_L06P_3	AA22
3	IO_L04N_3	Y22
3	IO_L04P_3	Y21
3	IO_L03N_3/VREF_3	W21

Table 76: BG575 BGA — XQ2V1000

Bank	Pin Description	Pin Number
3	IO_L03P_3	W20
3	IO_L02N_3/VRP_3	V20
3	IO_L02P_3/VRN_3	V19
3	IO_L01N_3	U18
3	IO_L01P_3	T17
4	IO_L01N_4/DOU	AD22
4	IO_L01P_4/INIT_B	AD21
4	IO_L02N_4/D0	AA20
4	IO_L02P_4/D1	AB20
4	IO_L03N_4/D2/ALT_VRP_4	Y19
4	IO_L03P_4/D3/ALT_VRN_4	AA19
4	IO_L04N_4/VREF_4	W18
4	IO_L04P_4	Y18
4	IO_L05N_4/VRP_4	U16
4	IO_L05P_4/VRN_4	V17
4	IO_L06N_4	AD20
4	IO_L06P_4	AD19
4	IO_L19N_4	AC20
4	IO_L19P_4	AC19
4	IO_L21N_4	AA18
4	IO_L21P_4/VREF_4	AB18
4	IO_L22N_4	AC18
4	IO_L22P_4	AC17
4	IO_L24N_4	AA17
4	IO_L24P_4	AB17
4	IO_L49N_4	Y17
4	IO_L49P_4	W17
4	IO_L51N_4	V16
4	IO_L51P_4/VREF_4	W16
4	IO_L52N_4	AD17
4	IO_L52P_4	AD16
4	IO_L54N_4	AB16
4	IO_L54P_4	AC16
4	IO_L67N_4	Y16

Table 76: BG575 BGA — XQ2V1000

Bank	Pin Description	Pin Number
4	IO_L67P_4	AA16
4	IO_L69N_4	W15
4	IO_L69P_4/VREF_4	Y15
4	IO_L70N_4	U15
4	IO_L70P_4	V15
4	IO_L72N_4	AD15
4	IO_L72P_4	AD14
4	IO_L73N_4	AB15
4	IO_L73P_4	AC15
4	IO_L91N_4/VREF_4	AA14
4	IO_L91P_4	AB14
4	IO_L92N_4	V14
4	IO_L92P_4	Y14
4	IO_L93N_4	AB13
4	IO_L93P_4	AC13
4	IO_L94N_4/VREF_4	Y13
4	IO_L94P_4	AA13
4	IO_L95N_4/GCLK3S	V13
4	IO_L95P_4/GCLK2P	W13
4	IO_L96N_4/GCLK1S	U14
4	IO_L96P_4/GCLK0P	U13
5	IO_L96N_5/GCLK7S	AD12
5	IO_L96P_5/GCLK6P	AD11
5	IO_L95N_5/GCLK5S	AC12
5	IO_L95P_5/GCLK4P	AB12
5	IO_L94N_5	AA12
5	IO_L94P_5/VREF_5	Y12
5	IO_L93N_5	W12
5	IO_L93P_5	V12
5	IO_L92N_5	U12
5	IO_L92P_5	U11
5	IO_L91N_5	AB11
5	IO_L91P_5/VREF_5	AA11
5	IO_L73N_5	Y11

Table 76: BG575 BGA — XQ2V1000

Bank	Pin Description	Pin Number
5	IO_L73P_5	V11
5	IO_L72N_5	AD10
5	IO_L72P_5	AD9
5	IO_L70N_5	AC10
5	IO_L70P_5	AB10
5	IO_L69N_5/VREF_5	Y10
5	IO_L69P_5	W10
5	IO_L67N_5	V10
5	IO_L67P_5	U10
5	IO_L54N_5	AC9
5	IO_L54P_5	AB9
5	IO_L52N_5	AA9
5	IO_L52P_5	Y9
5	IO_L51N_5/VREF_5	W9
5	IO_L51P_5	V9
5	IO_L49N_5	AD8
5	IO_L49P_5	AD6
5	IO_L24N_5	AC8
5	IO_L24P_5	AC7
5	IO_L22N_5	AB8
5	IO_L22P_5	AA8
5	IO_L21N_5/VREF_5	W8
5	IO_L21P_5	Y8
5	IO_L19N_5	AD5
5	IO_L19P_5	AD4
5	IO_L06N_5	AC6
5	IO_L06P_5	AC5
5	IO_L05N_5/VRP_5	AB7
5	IO_L05P_5/VRN_5	AA7
5	IO_L04N_5	AB5
5	IO_L04P_5/VREF_5	AA5
5	IO_L03N_5/D4/ALT_VRP_5	AA6
5	IO_L03P_5/D5/ALT_VRN_5	Y6
5	IO_L02N_5/D6	Y7
5	IO_L02P_5/D7	W7

Table 76: BG575 BGA — XQ2V1000

Bank	Pin Description	Pin Number
5	IO_L01N_5/RDWR_B	V8
5	IO_L01P_5/CS_B	U9
6	IO_L01P_6	AB2
6	IO_L01N_6	AB1
6	IO_L02P_6/VRN_6	AA3
6	IO_L02N_6/VRP_6	AA2
6	IO_L03P_6	Y4
6	IO_L03N_6/VREF_6	Y3
6	IO_L04P_6	W4
6	IO_L04N_6	W5
6	IO_L06P_6	V5
6	IO_L06N_6	V6
6	IO_L19P_6	U7
6	IO_L19N_6	T8
6	IO_L21P_6	AA1
6	IO_L21N_6/VREF_6	Y2
6	IO_L22P_6	Y1
6	IO_L22N_6	W1
6	IO_L24P_6	W2
6	IO_L24N_6	V2
6	IO_L43P_6	V4
6	IO_L43N_6	V3
6	IO_L45P_6	U6
6	IO_L45N_6/VREF_6	U5
6	IO_L46P_6	T7
6	IO_L46N_6	T6
6	IO_L48P_6	R8
6	IO_L48N_6	R7
6	IO_L49P_6	U2
6	IO_L49N_6	U1
6	IO_L51P_6	U4
6	IO_L51N_6/VREF_6	U3
6	IO_L52P_6	T1
6	IO_L52N_6	R1

Table 76: BG575 BGA — XQ2V1000

Bank	Pin Description	Pin Number
6	IO_L54P_6	T3
6	IO_L54N_6	T2
6	IO_L67P_6	T5
6	IO_L67N_6	T4
6	IO_L69P_6	R6
6	IO_L69N_6/VREF_6	R5
6	IO_L70P_6	P8
6	IO_L70N_6	P7
6	IO_L72P_6	R2
6	IO_L72N_6	P1
6	IO_L73P_6	R3
6	IO_L73N_6	P3
6	IO_L91P_6	P5
6	IO_L91N_6	P4
6	IO_L93P_6	N4
6	IO_L93N_6/VREF_6	N3
6	IO_L94P_6	N6
6	IO_L94N_6	N5
6	IO_L96P_6	N8
6	IO_L96N_6	N7
7	IO_L96P_7	N2
7	IO_L96N_7	M1
7	IO_L94P_7	M2
7	IO_L94N_7	M3
7	IO_L93P_7/VREF_7	M4
7	IO_L93N_7	M5
7	IO_L91P_7	M6
7	IO_L91N_7	M7
7	IO_L73P_7	M8
7	IO_L73N_7	L8
7	IO_L72P_7	L1
7	IO_L72N_7	K1
7	IO_L70P_7	K2
7	IO_L70N_7	K3

Table 76: BG575 BGA — XQ2V1000

Bank	Pin Description	Pin Number
7	IO_L69P_7/VREF_7	L3
7	IO_L69N_7	L4
7	IO_L67P_7	L5
7	IO_L67N_7	L7
7	IO_L54P_7	J1
7	IO_L54N_7	H1
7	IO_L52P_7	J2
7	IO_L52N_7	J3
7	IO_L51P_7/VREF_7	J4
7	IO_L51N_7	J5
7	IO_L49P_7	K5
7	IO_L49N_7	K6
7	IO_L48P_7	F1
7	IO_L48N_7	F2
7	IO_L46P_7	H2
7	IO_L46N_7	G2
7	IO_L45P_7/VREF_7	H3
7	IO_L45N_7	H4
7	IO_L43P_7	G3
7	IO_L43N_7	G4
7	IO_L24P_7	H5
7	IO_L24N_7	H6
7	IO_L22P_7	J6
7	IO_L22N_7	J7
7	IO_L21P_7/VREF_7	K7
7	IO_L21N_7	K8
7	IO_L19P_7	E1
7	IO_L19N_7	E2
7	IO_L06P_7	D2
7	IO_L06N_7	D3
7	IO_L04P_7	E3
7	IO_L04N_7	E4
7	IO_L03P_7/VREF_7	F4
7	IO_L03N_7	F5
7	IO_L02P_7/VRN_7	G5

Table 76: BG575 BGA — XQ2V1000

Bank	Pin Description	Pin Number
7	IO_L02N_7/VRP_7	G6
7	IO_L01P_7	H7
7	IO_L01N_7	J8
0	VCCO_0	J12
0	VCCO_0	J11
0	VCCO_0	J10
0	VCCO_0	F11
0	VCCO_0	C6
0	VCCO_0	B11
1	VCCO_1	J15
1	VCCO_1	J14
1	VCCO_1	J13
1	VCCO_1	F14
1	VCCO_1	C19
1	VCCO_1	B14
2	VCCO_2	M16
2	VCCO_2	L23
2	VCCO_2	L19
2	VCCO_2	L16
2	VCCO_2	K16
2	VCCO_2	F22
3	VCCO_3	W22
3	VCCO_3	R16
3	VCCO_3	P23
3	VCCO_3	P19
3	VCCO_3	P16
3	VCCO_3	N16
4	VCCO_4	AC14
4	VCCO_4	AB19
4	VCCO_4	W14
4	VCCO_4	T15
4	VCCO_4	T14
4	VCCO_4	T13
5	VCCO_5	AC11

Table 76: BG575 BGA — XQ2V1000

Bank	Pin Description	Pin Number
5	VCCO_5	AB6
5	VCCO_5	W11
5	VCCO_5	T12
5	VCCO_5	T11
5	VCCO_5	T10
6	VCCO_6	W3
6	VCCO_6	R9
6	VCCO_6	P9
6	VCCO_6	P6
6	VCCO_6	P2
6	VCCO_6	N9
7	VCCO_7	M9
7	VCCO_7	L9
7	VCCO_7	L6
7	VCCO_7	L2
7	VCCO_7	K9
7	VCCO_7	F3
NA	CCLK	AB23
NA	PROG_B	C1
NA	DONE	AB21
NA	M0	AC4
NA	M1	AB4
NA	M2	AD3
NA	HSWAP_EN	C2
NA	TCK	C23
NA	TDI	D1
NA	TDO	C24
NA	TMS	C21
NA	PWRDWN_B	AC21
NA	DXN	B4
NA	DXP	C4
NA	VBATT	B21
NA	RSVD	A22

Table 76: BG575 BGA — XQ2V1000

Bank	Pin Description	Pin Number
NA	VCCAUX	AD13
NA	VCCAUX	AC22
NA	VCCAUX	AC3
NA	VCCAUX	N1
NA	VCCAUX	M24
NA	VCCAUX	B22
NA	VCCAUX	B3
NA	VCCAUX	A12
NA	VCCINT	U17
NA	VCCINT	U8
NA	VCCINT	T16
NA	VCCINT	T9
NA	VCCINT	R15
NA	VCCINT	R14
NA	VCCINT	R13
NA	VCCINT	R12
NA	VCCINT	R11
NA	VCCINT	R10
NA	VCCINT	P15
NA	VCCINT	P10
NA	VCCINT	N15
NA	VCCINT	N10
NA	VCCINT	M15
NA	VCCINT	M10
NA	VCCINT	L15
NA	VCCINT	L10
NA	VCCINT	K15
NA	VCCINT	K14
NA	VCCINT	K13
NA	VCCINT	K12
NA	VCCINT	K11
NA	VCCINT	K10
NA	VCCINT	J16
NA	VCCINT	J9

Table 76: BG575 BGA — XQ2V1000

Bank	Pin Description	Pin Number
NA	VCCINT	H17
NA	VCCINT	H8
NA	GND	AD24
NA	GND	AD23
NA	GND	AD18
NA	GND	AD7
NA	GND	AD2
NA	GND	AD1
NA	GND	AC24
NA	GND	AC23
NA	GND	AC2
NA	GND	AC1
NA	GND	AB22
NA	GND	AB3
NA	GND	AA21
NA	GND	AA15
NA	GND	AA10
NA	GND	AA4
NA	GND	Y20
NA	GND	Y5
NA	GND	W19
NA	GND	W6
NA	GND	V24
NA	GND	V18
NA	GND	V7
NA	GND	V1
NA	GND	R21
NA	GND	R4
NA	GND	P14
NA	GND	P13
NA	GND	P12
NA	GND	P11
NA	GND	N14
NA	GND	N13
NA	GND	N12

Table 76: BG575 BGA — XQ2V1000

Bank	Pin Description	Pin Number
NA	GND	N11
NA	GND	M14
NA	GND	M13
NA	GND	M12
NA	GND	M11
NA	GND	L14
NA	GND	L13
NA	GND	L12
NA	GND	L11
NA	GND	K21
NA	GND	K4
NA	GND	G24
NA	GND	G18
NA	GND	G7
NA	GND	G1
NA	GND	F19
NA	GND	F6
NA	GND	E20
NA	GND	E5
NA	GND	D21
NA	GND	D15
NA	GND	D10
NA	GND	D4
NA	GND	C22
NA	GND	C3
NA	GND	B24
NA	GND	B23
NA	GND	B2
NA	GND	B1
NA	GND	A24
NA	GND	A23
NA	GND	A18
NA	GND	A7
NA	GND	A2

BG575 Standard BGA Package Specifications (1.27mm pitch)

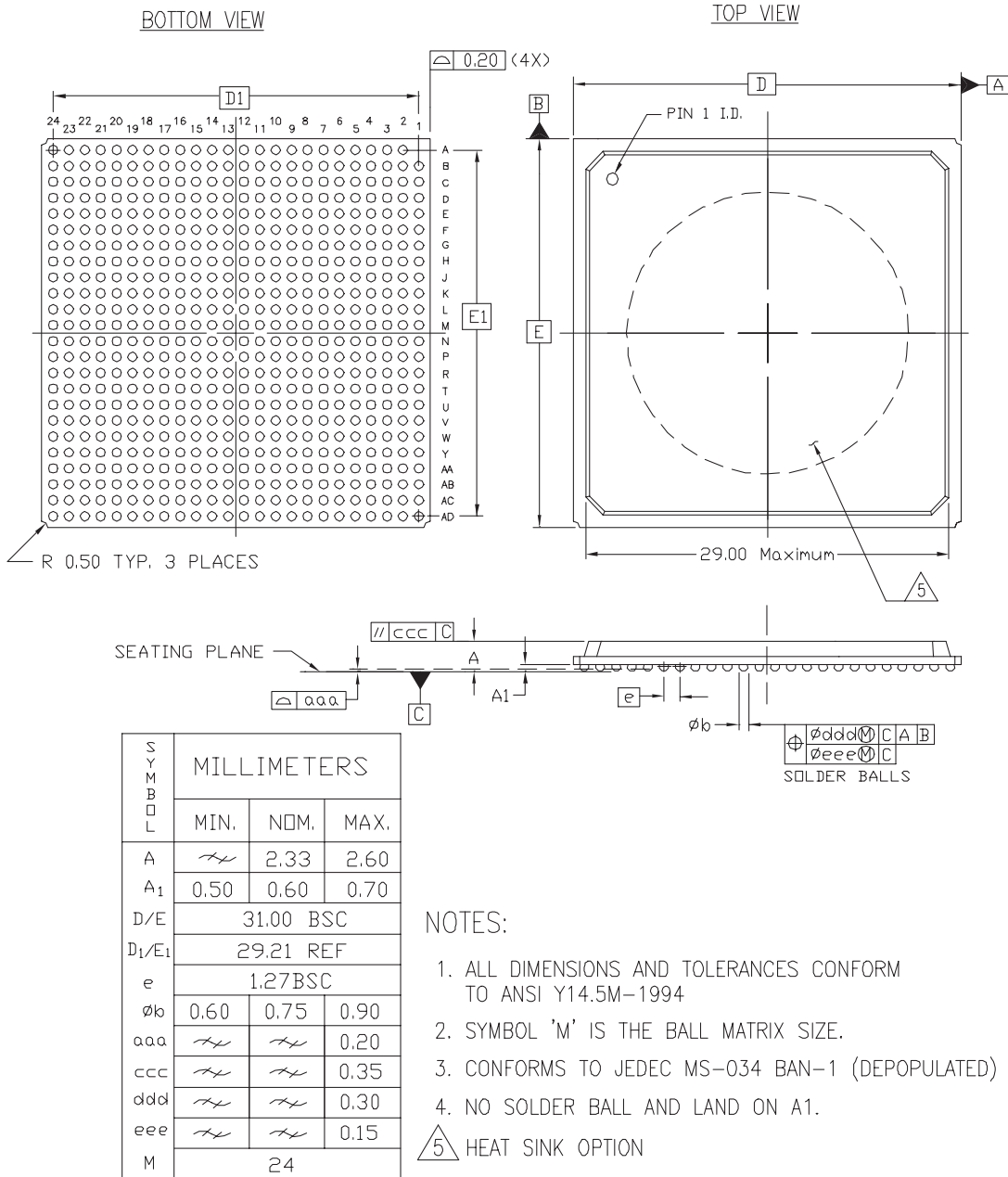

Figure 53: BG575 Standard BGA Package Specifications

BG728 Standard BGA and CG717 Ceramic CGA Packages

As shown in [Table 78](#), the XQ2V3000 QPro Virtex-II device is available in the BG728 BGA and CG717 CGA packages. The CG717 has identical pinout as the BG728 (except for those pins listed as Removed¹) and footprint compatibility. A summary of the removed pins is shown in [Table 77](#). Following this table are the **BG728 Standard BGA Package Specifications (1.27mm pitch)** and the **CG717 Ceramic Column Grid Array (CGA) Package Specifications (1.27mm pitch)**. The CG717 has 11 fewer GND pins than the BG728. The BG728 GND pin numbers missing on the CG717 are shown in [Table 77](#).

Table 77: BG728 GND Pins not available on the CG717¹

BG728 GND Pin Numbers			
A2	A27	AG1	AG26
B1	B27	AG2	AG27
A26	AF1	AF27	

1. Physical pin does not exist for CG717 package.

Table 78: BG728 BGA and CG717 CGA— XQ2V3000

Bank	Pin Description	Pin Number
0	IO_L01N_0	B3
0	IO_L01P_0	A3
0	IO_L02N_0	B4
0	IO_L02P_0	A4
0	IO_L03N_0/VRP_0	C5
0	IO_L03P_0/VRN_0	C6
0	IO_L04N_0/VREF_0	B5
0	IO_L04P_0	A5
0	IO_L05N_0	E6
0	IO_L05P_0	D6
0	IO_L06N_0	B6
0	IO_L06P_0	A6
0	IO_L19N_0	E7
0	IO_L19P_0	D8
0	IO_L21N_0	F8
0	IO_L21P_0/VREF_0	E8
0	IO_L22N_0	C7
0	IO_L22P_0	C8
0	IO_L24N_0	B7
0	IO_L24P_0	A7
0	IO_L25N_0	H9
0	IO_L25P_0	J9
0	IO_L27N_0	F9
0	IO_L27P_0/VREF_0	G9
0	IO_L28N_0	E9

Table 78: BG728 BGA and CG717 CGA— XQ2V3000

Bank	Pin Description	Pin Number
0	IO_L28P_0	D9
0	IO_L30N_0	C9
0	IO_L30P_0	B9
0	IO_L49N_0	A8
0	IO_L49P_0	A9
0	IO_L51N_0	G10
0	IO_L51P_0/VREF_0	H10
0	IO_L52N_0	F10
0	IO_L52P_0	E10
0	IO_L54N_0	D10
0	IO_L54P_0	C10
0	IO_L67N_0	B10
0	IO_L67P_0	A10
0	IO_L69N_0	G11
0	IO_L69P_0/VREF_0	H11
0	IO_L70N_0	F11
0	IO_L70P_0	F12
0	IO_L72N_0	D11
0	IO_L72P_0	C11
0	IO_L73N_0	B11
0	IO_L73P_0	A11
0	IO_L75N_0	H12
0	IO_L75P_0/VREF_0	J12
0	IO_L76N_0	E12
0	IO_L76P_0	D12

Table 78: BG728 BGA and CG717 CGA— XQ2V3000

Bank	Pin Description	Pin Number
0	IO_L78N_0	B12
0	IO_L78P_0	A12
0	IO_L91N_0/VREF_0	J13
0	IO_L91P_0	H13
0	IO_L92N_0	G13
0	IO_L92P_0	F13
0	IO_L93N_0	E13
0	IO_L93P_0	D13
0	IO_L94N_0/VREF_0	B13
0	IO_L94P_0	A13
0	IO_L95N_0/GCLK7P	C13
0	IO_L95P_0/GCLK6S	C14
0	IO_L96N_0/GCLK5P	F14
0	IO_L96P_0/GCLK4S	E14
1	IO_L96N_1/GCLK3P	G14
1	IO_L96P_1/GCLK2S	H14
1	IO_L95N_1/GCLK1P	A15
1	IO_L95P_1/GCLK0S	B15
1	IO_L94N_1	C15
1	IO_L94P_1/VREF_1	D15
1	IO_L93N_1	E15
1	IO_L93P_1	F15
1	IO_L92N_1	G15
1	IO_L92P_1	H15
1	IO_L91N_1	J15
1	IO_L91P_1/VREF_1	J16
1	IO_L78N_1	A16
1	IO_L78P_1	B16
1	IO_L76N_1	D16
1	IO_L76P_1	E16
1	IO_L75N_1/VREF_1	F16
1	IO_L75P_1	F17
1	IO_L73N_1	H16
1	IO_L73P_1	H17

Table 78: BG728 BGA and CG717 CGA— XQ2V3000

Bank	Pin Description	Pin Number
1	IO_L72N_1	A17
1	IO_L72P_1	B17
1	IO_L70N_1	C17
1	IO_L70P_1	D17
1	IO_L69N_1/VREF_1	G18
1	IO_L69P_1	G17
1	IO_L67N_1	A18
1	IO_L67P_1	B18
1	IO_L54N_1	C18
1	IO_L54P_1	D18
1	IO_L52N_1	E18
1	IO_L52P_1	F18
1	IO_L51N_1/VREF_1	H19
1	IO_L51P_1	H18
1	IO_L49N_1	A19
1	IO_L49P_1	A20
1	IO_L30N_1	B19
1	IO_L30P_1	C19
1	IO_L28N_1	D19
1	IO_L28P_1	E19
1	IO_L27N_1/VREF_1	F19
1	IO_L27P_1	G19
1	IO_L25N_1	J19
1	IO_L25P_1	J20
1	IO_L24N_1	C20
1	IO_L24P_1	C21
1	IO_L22N_1	D20
1	IO_L22P_1	E21
1	IO_L21N_1/VREF_1	E20
1	IO_L21P_1	F20
1	IO_L19N_1	A21
1	IO_L19P_1	B21
1	IO_L06N_1	A22
1	IO_L06P_1	B22
1	IO_L05N_1	C22

Table 78: BG728 BGA and CG717 CGA— XQ2V3000

Bank	Pin Description	Pin Number
1	IO_L05P_1	C23
1	IO_L04N_1	D22
1	IO_L04P_1/VREF_1	E22
1	IO_L03N_1/VRP_1	A23
1	IO_L03P_1/VRN_1	B23
1	IO_L02N_1	A24
1	IO_L02P_1	B24
1	IO_L01N_1	A25
1	IO_L01P_1	B25
2	IO_L01N_2	C27
2	IO_L01P_2	D27
2	IO_L02N_2/VRP_2	D25
2	IO_L02P_2/VRN_2	D26
2	IO_L03N_2	E24
2	IO_L03P_2/VREF_2	E25
2	IO_L04N_2	E26
2	IO_L04P_2	E27
2	IO_L06N_2	F23
2	IO_L06P_2	F24
2	IO_L19N_2	F25
2	IO_L19P_2	F26
2	IO_L21N_2	F27
2	IO_L21P_2/VREF_2	G27
2	IO_L22N_2	G23
2	IO_L22P_2	H23
2	IO_L24N_2	G25
2	IO_L24P_2	G26
2	IO_L25N_2	H21
2	IO_L25P_2	J21
2	IO_L27N_2	H22
2	IO_L27P_2/VREF_2	J22
2	IO_L28N_2	H24
2	IO_L28P_2	H25
2	IO_L30N_2	H27

Table 78: BG728 BGA and CG717 CGA— XQ2V3000

Bank	Pin Description	Pin Number
2	IO_L30P_2	J27
2	IO_L43N_2	J23
2	IO_L43P_2	J24
2	IO_L45N_2	J25
2	IO_L45P_2/VREF_2	J26
2	IO_L46N_2	K20
2	IO_L46P_2	K21
2	IO_L48N_2	K22
2	IO_L48P_2	K23
2	IO_L49N_2	K24
2	IO_L49P_2	K25
2	IO_L51N_2	K26
2	IO_L51P_2/VREF_2	K27
2	IO_L52N_2	L20
2	IO_L52P_2	M20
2	IO_L54N_2	L21
2	IO_L54P_2	L22
2	IO_L67N_2	L24
2	IO_L67P_2	L25
2	IO_L69N_2	L26
2	IO_L69P_2/VREF_2	L27
2	IO_L70N_2	M19
2	IO_L70P_2	N19
2	IO_L72N_2	M22
2	IO_L72P_2	M23
2	IO_L73N_2	M24
2	IO_L73P_2	N24
2	IO_L75N_2	M26
2	IO_L75P_2/VREF_2	M27
2	IO_L76N_2	N20
2	IO_L76P_2	N21
2	IO_L78N_2	N22
2	IO_L78P_2	N23
2	IO_L91N_2	N25
2	IO_L91P_2	P25

Table 78: BG728 BGA and CG717 CGA— XQ2V3000

Bank	Pin Description	Pin Number
2	IO_L93N_2	N26
2	IO_L93P_2/VREF_2	N27
2	IO_L94N_2	P20
2	IO_L94P_2	P21
2	IO_L96N_2	P22
2	IO_L96P_2	P23
3	IO_L96N_3	R27
3	IO_L96P_3	R26
3	IO_L94N_3	R25
3	IO_L94P_3	R24
3	IO_L93N_3/VREF_3	R23
3	IO_L93P_3	T23
3	IO_L91N_3	R22
3	IO_L91P_3	R21
3	IO_L78N_3	R20
3	IO_L78P_3	R19
3	IO_L76N_3	T27
3	IO_L76P_3	T26
3	IO_L75N_3/VREF_3	T24
3	IO_L75P_3	U24
3	IO_L73N_3	T22
3	IO_L73P_3	U22
3	IO_L72N_3	T20
3	IO_L72P_3	T19
3	IO_L70N_3	U27
3	IO_L70P_3	U26
3	IO_L69N_3/VREF_3	U25
3	IO_L69P_3	V25
3	IO_L67N_3	U21
3	IO_L67P_3	U20
3	IO_L54N_3	V27
3	IO_L54P_3	V26
3	IO_L52N_3	V24
3	IO_L52P_3	V23

Table 78: BG728 BGA and CG717 CGA— XQ2V3000

Bank	Pin Description	Pin Number
3	IO_L51N_3/VREF_3	V22
3	IO_L51P_3	W22
3	IO_L49N_3	V21
3	IO_L49P_3	V20
3	IO_L48N_3	W27
3	IO_L48P_3	Y27
3	IO_L46N_3	W26
3	IO_L46P_3	W25
3	IO_L45N_3/VREF_3	W24
3	IO_L45P_3	W23
3	IO_L43N_3	W21
3	IO_L43P_3	W20
3	IO_L28N_3	W19
3	IO_L28P_3	Y19
3	IO_L27N_3/VREF_3	Y25
3	IO_L27P_3	Y24
3	IO_L25N_3	Y23
3	IO_L25P_3	AA23
3	IO_L24N_3	Y22
3	IO_L24P_3	Y21
3	IO_L22N_3	AA27
3	IO_L22P_3	AB27
3	IO_L21N_3/VREF_3	AA26
3	IO_L21P_3	AA25
3	IO_L19N_3	AB26
3	IO_L19P_3	AB25
3	IO_L06N_3	AB24
3	IO_L06P_3	AB23
3	IO_L04N_3	AC27
3	IO_L04P_3	AC26
3	IO_L03N_3/VREF_3	AC25
3	IO_L03P_3	AC24
3	IO_L02N_3/VRP_3	AD27
3	IO_L02P_3/VRN_3	AE27
3	IO_L01N_3	AD26

Table 78: BG728 BGA and CG717 CGA— XQ2V3000

Bank	Pin Description	Pin Number
3	IO_L01P_3	AD25
4	IO_L01N_4/DOUT	AF25
4	IO_L01P_4/INIT_B	AG25
4	IO_L02N_4/D0	AF24
4	IO_L02P_4/D1	AG24
4	IO_L03N_4/D2/ALT_VRP_4	AD23
4	IO_L03P_4/D3/ALT_VRN_4	AE23
4	IO_L04N_4/VREF_4	AF23
4	IO_L04P_4	AG23
4	IO_L05N_4/VRP_4	AD22
4	IO_L05P_4/VRN_4	AE22
4	IO_L06N_4	AF22
4	IO_L06P_4	AG22
4	IO_L19N_4	AC21
4	IO_L19P_4	AB21
4	IO_L21N_4	AE21
4	IO_L21P_4/VREF_4	AE20
4	IO_L22N_4	AF21
4	IO_L22P_4	AG21
4	IO_L24N_4	AB20
4	IO_L24P_4	AA20
4	IO_L25N_4	AC20
4	IO_L25P_4	AD20
4	IO_L27N_4	AG20
4	IO_L27P_4/VREF_4	AG19
4	IO_L28N_4	AB19
4	IO_L28P_4	AA19
4	IO_L30N_4	AC19
4	IO_L30P_4	AD19
4	IO_L49N_4	AE19
4	IO_L49P_4	AF19
4	IO_L51N_4	AA18
4	IO_L51P_4/VREF_4	Y18
4	IO_L52N_4	AB18

Table 78: BG728 BGA and CG717 CGA— XQ2V3000

Bank	Pin Description	Pin Number
4	IO_L52P_4	AC18
4	IO_L54N_4	AD18
4	IO_L54P_4	AE18
4	IO_L67N_4	AF18
4	IO_L67P_4	AG18
4	IO_L69N_4	AA17
4	IO_L69P_4/VREF_4	Y17
4	IO_L70N_4	AB17
4	IO_L70P_4	AB16
4	IO_L72N_4	AD17
4	IO_L72P_4	AE17
4	IO_L73N_4	AF17
4	IO_L73P_4	AG17
4	IO_L75N_4	Y16
4	IO_L75P_4/VREF_4	W16
4	IO_L76N_4	AC16
4	IO_L76P_4	AD16
4	IO_L78N_4	AF16
4	IO_L78P_4	AG16
4	IO_L91N_4/VREF_4	W15
4	IO_L91P_4	Y15
4	IO_L92N_4	AB15
4	IO_L92P_4	AA15
4	IO_L93N_4	AC15
4	IO_L93P_4	AD15
4	IO_L94N_4/VREF_4	AE15
4	IO_L94P_4	AE14
4	IO_L95N_4/GCLK3S	AF15
4	IO_L95P_4/GCLK2P	AG15
4	IO_L96N_4/GCLK1S	Y14
4	IO_L96P_4/GCLK0P	AA14
5	IO_L96N_5/GCLK7S	AC14
5	IO_L96P_5/GCLK6P	AB14
5	IO_L95N_5/GCLK5S	AG13

Table 78: BG728 BGA and CG717 CGA— XQ2V3000

Bank	Pin Description	Pin Number
5	IO_L95P_5/GCLK4P	AF13
5	IO_L94N_5	AE13
5	IO_L94P_5/VREF_5	AD13
5	IO_L93N_5	AC13
5	IO_L93P_5	AB13
5	IO_L92N_5	AA13
5	IO_L92P_5	Y13
5	IO_L91N_5	W13
5	IO_L91P_5/VREF_5	W12
5	IO_L78N_5	AG12
5	IO_L78P_5	AF12
5	IO_L76N_5	AD12
5	IO_L76P_5	AC12
5	IO_L75N_5/VREF_5	AB12
5	IO_L75P_5	AB11
5	IO_L73N_5	Y12
5	IO_L73P_5	Y11
5	IO_L72N_5	AG11
5	IO_L72P_5	AF11
5	IO_L70N_5	AE11
5	IO_L70P_5	AD11
5	IO_L69N_5/VREF_5	AA10
5	IO_L69P_5	AA11
5	IO_L67N_5	AG10
5	IO_L67P_5	AF10
5	IO_L54N_5	AE10
5	IO_L54P_5	AD10
5	IO_L52N_5	AC10
5	IO_L52P_5	AB10
5	IO_L51N_5/VREF_5	Y9
5	IO_L51P_5	Y10
5	IO_L49N_5	AG9
5	IO_L49P_5	AG8
5	IO_L30N_5	AF9
5	IO_L30P_5	AE9

Table 78: BG728 BGA and CG717 CGA— XQ2V3000

Bank	Pin Description	Pin Number
5	IO_L28N_5	AD9
5	IO_L28P_5	AC9
5	IO_L27N_5/VREF_5	AB9
5	IO_L27P_5	AA9
5	IO_L25N_5	AE8
5	IO_L25P_5	AE7
5	IO_L24N_5	AD8
5	IO_L24P_5	AC8
5	IO_L22N_5	AB8
5	IO_L22P_5	AA8
5	IO_L21N_5/VREF_5	AG7
5	IO_L21P_5	AF7
5	IO_L19N_5	AC7
5	IO_L19P_5	AB7
5	IO_L06N_5	AG6
5	IO_L06P_5	AF6
5	IO_L05N_5/VRP_5	AE6
5	IO_L05P_5/VRN_5	AD6
5	IO_L04N_5	AG5
5	IO_L04P_5/VREF_5	AF5
5	IO_L03N_5/D4/ALT_VRP_5	AE5
5	IO_L03P_5/D5/ALT_VRN_5	AD5
5	IO_L02N_5/D6	AG4
5	IO_L02P_5/D7	AF4
5	IO_L01N_5/RDWR_B	AG3
5	IO_L01P_5/CS_B	AF3
6	IO_L01P_6	AE1
6	IO_L01N_6	AD1
6	IO_L02P_6/VRN_6	AD3
6	IO_L02N_6/VRP_6	AD2
6	IO_L03P_6	AC4
6	IO_L03N_6/VREF_6	AC3
6	IO_L04P_6	AC2
6	IO_L04N_6	AC1

Table 78: BG728 BGA and CG717 CGA— XQ2V3000

Bank	Pin Description	Pin Number
6	IO_L06P_6	AB5
6	IO_L06N_6	AB4
6	IO_L19P_6	AB3
6	IO_L19N_6	AB2
6	IO_L21P_6	AB1
6	IO_L21N_6/VREF_6	AA1
6	IO_L22P_6	AA5
6	IO_L22N_6	AA6
6	IO_L24P_6	AA3
6	IO_L24N_6	AA2
6	IO_L25P_6	Y5
6	IO_L25N_6	Y6
6	IO_L27P_6	Y4
6	IO_L27N_6/VREF_6	Y3
6	IO_L28P_6	Y1
6	IO_L28N_6	W1
6	IO_L43P_6	W8
6	IO_L43N_6	W9
6	IO_L45P_6	W6
6	IO_L45N_6/VREF_6	W7
6	IO_L46P_6	W5
6	IO_L46N_6	W4
6	IO_L48P_6	W3
6	IO_L48N_6	W2
6	IO_L49P_6	V7
6	IO_L49N_6	V8
6	IO_L51P_6	V5
6	IO_L51N_6/VREF_6	V6
6	IO_L52P_6	V4
6	IO_L52N_6	V3
6	IO_L54P_6	V2
6	IO_L54N_6	V1
6	IO_L67P_6	U8
6	IO_L67N_6	T8
6	IO_L69P_6	U6

Table 78: BG728 BGA and CG717 CGA— XQ2V3000

Bank	Pin Description	Pin Number
6	IO_L69N_6/VREF_6	U7
6	IO_L70P_6	U4
6	IO_L70N_6	U3
6	IO_L72P_6	U2
6	IO_L72N_6	U1
6	IO_L73P_6	T9
6	IO_L73N_6	R9
6	IO_L75P_6	T5
6	IO_L75N_6/VREF_6	T6
6	IO_L76P_6	T4
6	IO_L76N_6	R4
6	IO_L78P_6	T2
6	IO_L78N_6	T1
6	IO_L91P_6	R7
6	IO_L91N_6	R8
6	IO_L93P_6	R5
6	IO_L93N_6/VREF_6	R6
6	IO_L94P_6	R3
6	IO_L94N_6	P3
6	IO_L96P_6	R2
6	IO_L96N_6	R1
7	IO_L96P_7	P5
7	IO_L96N_7	P6
7	IO_L94P_7	P7
7	IO_L94N_7	P8
7	IO_L93P_7/VREF_7	N1
7	IO_L93N_7	N2
7	IO_L91P_7	N3
7	IO_L91N_7	N4
7	IO_L78P_7	N6
7	IO_L78N_7	N7
7	IO_L76P_7	N9
7	IO_L76N_7	N8
7	IO_L75P_7/VREF_7	N5

Table 78: BG728 BGA and CG717 CGA— XQ2V3000

Bank	Pin Description	Pin Number
7	IO_L75N_7	M6
7	IO_L73P_7	M1
7	IO_L73N_7	M2
7	IO_L72P_7	M4
7	IO_L72N_7	M5
7	IO_L70P_7	M8
7	IO_L70N_7	M9
7	IO_L69P_7/VREF_7	L1
7	IO_L69N_7	L2
7	IO_L67P_7	L3
7	IO_L67N_7	L4
7	IO_L54P_7	K1
7	IO_L54N_7	K2
7	IO_L52P_7	K4
7	IO_L52N_7	K5
7	IO_L51P_7/VREF_7	L6
7	IO_L51N_7	L7
7	IO_L49P_7	K6
7	IO_L49N_7	K7
7	IO_L48P_7	L8
7	IO_L48N_7	K8
7	IO_L46P_7	J1
7	IO_L46N_7	H1
7	IO_L45P_7/VREF_7	J2
7	IO_L45N_7	J3
7	IO_L43P_7	K3
7	IO_L43N_7	J4
7	IO_L30P_7	H3
7	IO_L30N_7	H4
7	IO_L28P_7	J5
7	IO_L28N_7	J6
7	IO_L27P_7/VREF_7	H5
7	IO_L27N_7	H6
7	IO_L25P_7	J7
7	IO_L25N_7	J8

Table 78: BG728 BGA and CG717 CGA— XQ2V3000

Bank	Pin Description	Pin Number
7	IO_L24P_7	G1
7	IO_L24N_7	F1
7	IO_L22P_7	G2
7	IO_L22N_7	G3
7	IO_L21P_7/VREF_7	F2
7	IO_L21N_7	F3
7	IO_L19P_7	G5
7	IO_L19N_7	G6
7	IO_L06P_7	F4
7	IO_L06N_7	F5
7	IO_L04P_7	E1
7	IO_L04N_7	E2
7	IO_L03P_7/VREF_7	D1
7	IO_L03N_7	C1
7	IO_L02P_7/VRN_7	E3
7	IO_L02N_7/VRP_7	E4
7	IO_L01P_7	D2
7	IO_L01N_7	D3
0	VCCO_0	K13
0	VCCO_0	K12
0	VCCO_0	K11
0	VCCO_0	J11
0	VCCO_0	J10
0	VCCO_0	G12
0	VCCO_0	D7
0	VCCO_0	C12
1	VCCO_1	K17
1	VCCO_1	K16
1	VCCO_1	K15
1	VCCO_1	J18
1	VCCO_1	J17
1	VCCO_1	G16
1	VCCO_1	D21
1	VCCO_1	C16

Table 78: BG728 BGA and CG717 CGA— XQ2V3000

Bank	Pin Description	Pin Number
2	VCCO_2	N18
2	VCCO_2	M25
2	VCCO_2	M21
2	VCCO_2	M18
2	VCCO_2	L19
2	VCCO_2	L18
2	VCCO_2	K19
2	VCCO_2	G24
3	VCCO_3	AA24
3	VCCO_3	V19
3	VCCO_3	U19
3	VCCO_3	U18
3	VCCO_3	T25
3	VCCO_3	T21
3	VCCO_3	T18
3	VCCO_3	R18
4	VCCO_4	AE16
4	VCCO_4	AD21
4	VCCO_4	AA16
4	VCCO_4	W18
4	VCCO_4	W17
4	VCCO_4	V17
4	VCCO_4	V16
4	VCCO_4	V15
5	VCCO_5	AE12
5	VCCO_5	AD7
5	VCCO_5	AA12
5	VCCO_5	W11
5	VCCO_5	W10
5	VCCO_5	V13
5	VCCO_5	V12
5	VCCO_5	V11
6	VCCO_6	AA4
6	VCCO_6	V9
6	VCCO_6	U10

Table 78: BG728 BGA and CG717 CGA— XQ2V3000

Bank	Pin Description	Pin Number
6	VCCO_6	U9
6	VCCO_6	T10
6	VCCO_6	T7
6	VCCO_6	T3
6	VCCO_6	R10
7	VCCO_7	M10
7	VCCO_7	M7
7	VCCO_7	M3
7	VCCO_7	L10
7	VCCO_7	L9
7	VCCO_7	K9
7	VCCO_7	G4
7	VCCO_7	N10
NA	CCLK	AA22
NA	PROG_B	C4
NA	DONE	AC22
NA	M0	AC6
NA	M1	Y7
NA	M2	AE4
NA	HSWAP_EN	D5
NA	TCK	G20
NA	TDI	H7
NA	TDO	G22
NA	TMS	F21
NA	PWRDWN_B	AE24
NA	DXN	G8
NA	DXP	F7
NA	VBATT	D23
NA	RSVD	C24
NA	VCCAUX	AF14
NA	VCCAUX	AE26
NA	VCCAUX	AE2
NA	VCCAUX	P26

Table 78: BG728 BGA and CG717 CGA— XQ2V3000

Bank	Pin Description	Pin Number
NA	VCCAUX	P2
NA	VCCAUX	C26
NA	VCCAUX	C2
NA	VCCAUX	B14
NA	VCCINT	V18
NA	VCCINT	V14
NA	VCCINT	V10
NA	VCCINT	U17
NA	VCCINT	U16
NA	VCCINT	U15
NA	VCCINT	U14
NA	VCCINT	U13
NA	VCCINT	U12
NA	VCCINT	U11
NA	VCCINT	T17
NA	VCCINT	T11
NA	VCCINT	R17
NA	VCCINT	R11
NA	VCCINT	P18
NA	VCCINT	P17
NA	VCCINT	P11
NA	VCCINT	P10
NA	VCCINT	N17
NA	VCCINT	N11
NA	VCCINT	M17
NA	VCCINT	M11
NA	VCCINT	L17
NA	VCCINT	L16
NA	VCCINT	L15
NA	VCCINT	L14
NA	VCCINT	L13
NA	VCCINT	L12
NA	VCCINT	L11
NA	VCCINT	K18
NA	VCCINT	K14

Table 78: BG728 BGA and CG717 CGA— XQ2V3000

Bank	Pin Description	Pin Number
NA	VCCINT	K10
NA	GND	AG27 ¹
NA	GND	AG26 ¹
NA	GND	AG14
NA	GND	AG2 ¹
NA	GND	AG1 ¹
NA	GND	AF27 ¹
NA	GND	AF26
NA	GND	AF20
NA	GND	AF8
NA	GND	AF2
NA	GND	AF1 ¹
NA	GND	AE25
NA	GND	AE3
NA	GND	AD24
NA	GND	AD14
NA	GND	AD4
NA	GND	AC23
NA	GND	AC17
NA	GND	AC11
NA	GND	AC5
NA	GND	AB22
NA	GND	AB6
NA	GND	AA21
NA	GND	AA7
NA	GND	Y26
NA	GND	Y20
NA	GND	Y8
NA	GND	Y2
NA	GND	W14
NA	GND	U23
NA	GND	U5
NA	GND	T16
NA	GND	T15
NA	GND	T14

Table 78: BG728 BGA and CG717 CGA— XQ2V3000

Bank	Pin Description	Pin Number
NA	GND	T13
NA	GND	T12
NA	GND	R16
NA	GND	R15
NA	GND	R14
NA	GND	R13
NA	GND	R12
NA	GND	P27
NA	GND	P24
NA	GND	P19
NA	GND	P16
NA	GND	P15
NA	GND	P14
NA	GND	P13
NA	GND	P12
NA	GND	P9
NA	GND	P4
NA	GND	P1
NA	GND	N16
NA	GND	N15
NA	GND	N14
NA	GND	N13
NA	GND	N12
NA	GND	M16
NA	GND	M15
NA	GND	M14
NA	GND	M13
NA	GND	M12
NA	GND	L23
NA	GND	L5
NA	GND	J14
NA	GND	H26
NA	GND	H20
NA	GND	H8
NA	GND	H2

Table 78: BG728 BGA and CG717 CGA— XQ2V3000

Bank	Pin Description	Pin Number
NA	GND	G21
NA	GND	G7
NA	GND	F22
NA	GND	F6
NA	GND	E23
NA	GND	E17
NA	GND	E11
NA	GND	E5
NA	GND	D24
NA	GND	D14
NA	GND	D4
NA	GND	C25
NA	GND	C3
NA	GND	B27 ¹
NA	GND	B26
NA	GND	B20
NA	GND	B8
NA	GND	B2
NA	GND	B1 ¹
NA	GND	A27 ¹
NA	GND	A26 ¹
NA	GND	A14
NA	GND	A2

BG728 Standard BGA Package Specifications (1.27mm pitch)

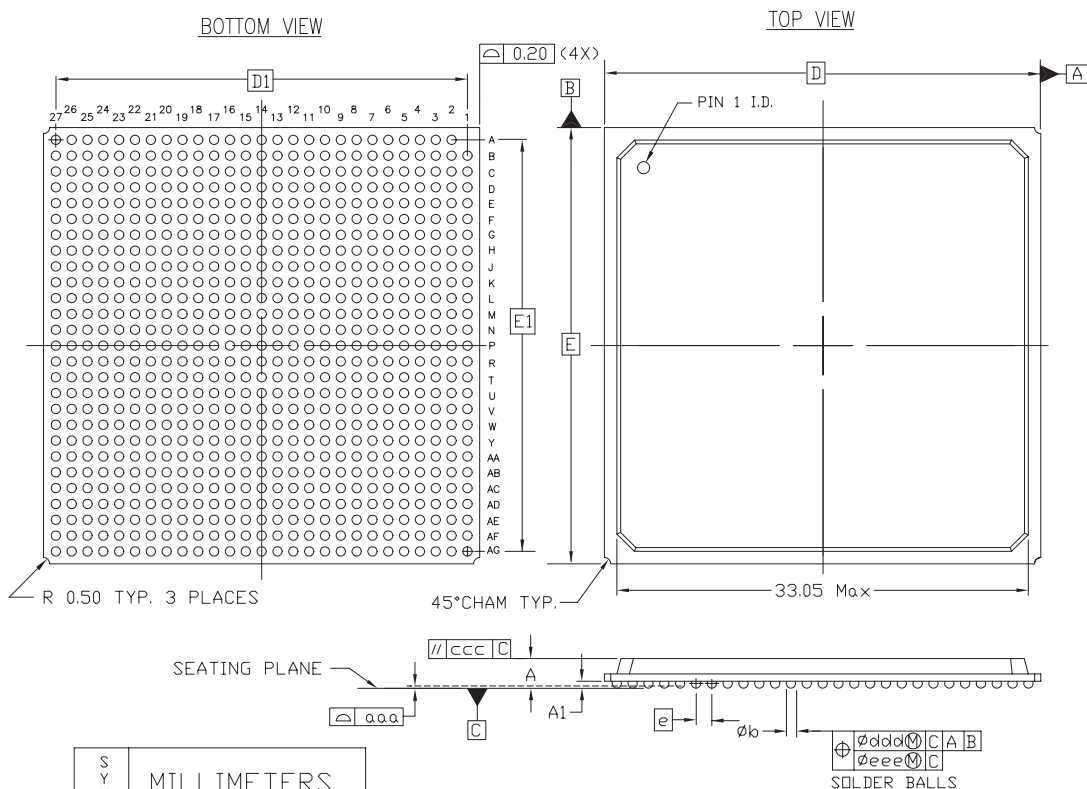

NOTES:

1. ALL DIMENSIONS AND TOLERANCES CONFORM TO ANSI Y14.5M-1994
2. SYMBOL 'M' IS THE BALL MATRIX SIZE.
3. CONFORMS TO JEDEC MS-034-BAR-1
4. NO SOLDER BALL AND LAND ON A1.

Figure 54: BG728 Standard BGA Package Specifications

CG717 Ceramic Column Grid Array (CGA) Package Specifications (1.27mm pitch)

CG717 (LGA WITH CAST SOLDER COLUMN)

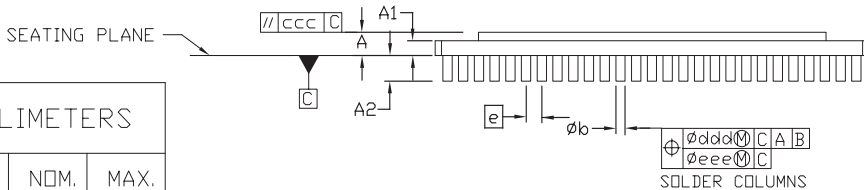
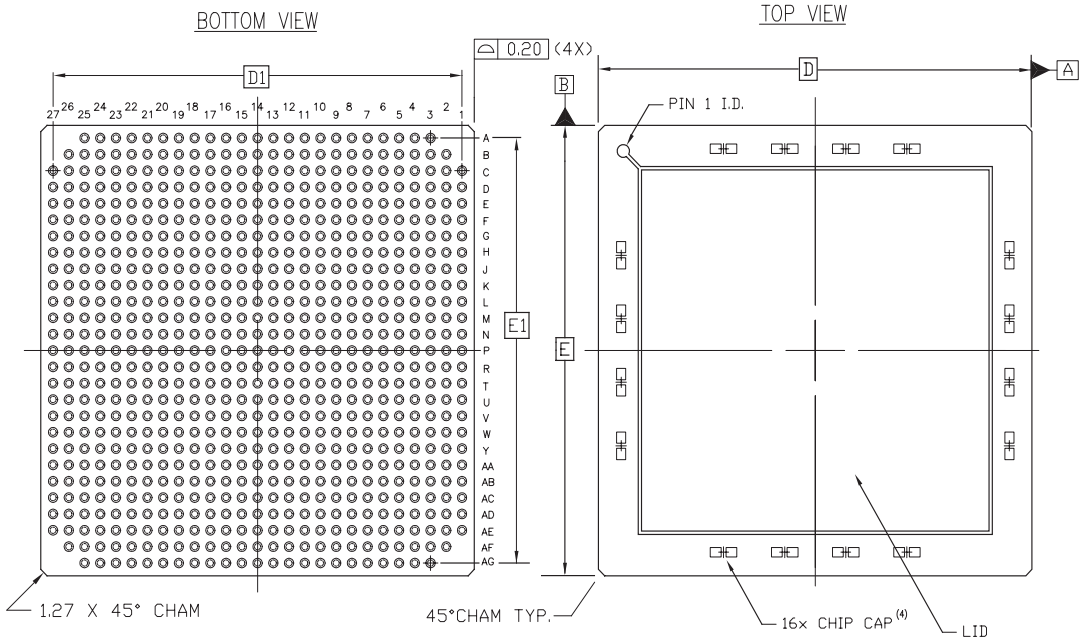

SYMBOL	MILLIMETERS		
	MIN.	NOM.	MAX.
A	$\sqrt{\text{---}}$	3.00	3.30
A ₁	2.30	2.56	2.82
A ₂	2.10	2.20	2.30
D/E ₁	35.00 BSC		
D ₁ /E	33.00 REF		
e	1.27BSC		
ϕ_b	0.51	0.54	0.57
ccc	$\sqrt{\text{---}}$	$\sqrt{\text{---}}$	0.35
ddd	$\sqrt{\text{---}}$	$\sqrt{\text{---}}$	0.30
eee	$\sqrt{\text{---}}$	$\sqrt{\text{---}}$	0.15
M	27		

NOTES:

1. ALL DIMENSIONS AND TOLERANCES CONFORM TO ANSI Y14.5M-1994
2. SYMBOL 'M' IS THE BALL MATRIX SIZE.
3. LEAD FINISH: HIGH TEMP. SOLDER Pb(90%)/Sn(10%)
4. 0402 CHIP CAPACITORS OPTIONAL

Figure 55: CG717 Ceramic CGA Package Specifications

CF1144 Ceramic Flip-Chip Fine-Pitch CGA Package

As shown in [Table 80](#), The XQ2V6000 QPro Virtex-II device is available in the CF1144 flip-chip fine-pitch CGA package. Pins for this package are the same as the FF1152, except for those pins shown in [Table 79](#) have been removed. Following this table are the **CF1144 Ceramic Flip-Chip Fine-Pitch CGA Package Specifications (1.00mm pitch)**. The CF1144 has eight fewer GND pins than the FF1152. The FF1152 GND Pin numbers missing on the CF1144 are shown in [Table 79](#).

Table 79: FF1152 GND Pins not available on the CF1144

FF1152 GND Pin Numbers			
A2	A33	AN1	AN34
B1	B34	AP2	AP33

1. Physical pin does not exist for CF1144 package

Table 80: CF1144 CGA — XQ2V6000

Bank	Pin Description	Pin Number
0	IO_L01N_0	D29
0	IO_L01P_0	C29
0	IO_L02N_0	H26
0	IO_L02P_0	G26
0	IO_L03N_0/VRP_0	E28
0	IO_L03P_0/VRN_0	E27
0	IO_L04N_0/VREF_0	F25
0	IO_L04P_0	F26
0	IO_L05N_0	H25
0	IO_L05P_0	H24
0	IO_L06N_0	E26
0	IO_L06P_0	F27
0	IO_L19N_0	B32
0	IO_L19P_0	C33
0	IO_L20N_0	J24
0	IO_L20P_0	J23
0	IO_L21N_0	C27
0	IO_L21P_0/VREF_0	C28
0	IO_L22N_0	B30
0	IO_L22P_0	B31
0	IO_L23N_0	K23
0	IO_L23P_0	K22
0	IO_L24N_0	C26
0	IO_L24P_0	D27
0	IO_L25N_0	A30
0	IO_L25P_0	A31

Table 80: CF1144 CGA — XQ2V6000

Bank	Pin Description	Pin Number
0	IO_L26N_0	G24
0	IO_L26P_0	G25
0	IO_L27N_0	E25
0	IO_L27P_0/VREF_0	E24
0	IO_L28N_0	D25
0	IO_L28P_0	D26
0	IO_L29N_0	H23
0	IO_L29P_0	H22
0	IO_L30N_0	F23
0	IO_L30P_0	F24
0	IO_L49N_0	B28
0	IO_L49P_0	B29
0	IO_L50N_0	J22
0	IO_L50P_0	J21
0	IO_L51N_0	A28
0	IO_L51P_0/VREF_0	A29
0	IO_L52N_0	A26
0	IO_L52P_0	B27
0	IO_L53N_0	C24
0	IO_L53P_0	D24
0	IO_L54N_0	D22
0	IO_L54P_0	D23
0	IO_L60N_0	B25
0	IO_L60P_0	B26
0	IO_L67N_0	B23
0	IO_L67P_0	B24

Table 80: CF1144 CGA — XQ2V6000

Bank	Pin Description	Pin Number
0	IO_L68N_0	G22
0	IO_L68P_0	G23
0	IO_L69N_0	F22
0	IO_L69P_0/VREF_0	F21
0	IO_L70N_0	A23
0	IO_L70P_0	A24
0	IO_L71N_0	K21
0	IO_L71P_0	K20
0	IO_L72N_0	C22
0	IO_L72P_0	C23
0	IO_L73N_0	E21
0	IO_L73P_0	E22
0	IO_L74N_0	H21
0	IO_L74P_0	H20
0	IO_L75N_0	G20
0	IO_L75P_0/VREF_0	F20
0	IO_L76N_0	B21
0	IO_L76P_0	B22
0	IO_L77N_0	J20
0	IO_L77P_0	K19
0	IO_L78N_0	D20
0	IO_L78P_0	D21
0	IO_L79N_0	A21
0	IO_L79P_0	A22
0	IO_L80N_0	L19
0	IO_L80P_0	L18
0	IO_L81N_0	B19
0	IO_L81P_0/VREF_0	A20
0	IO_L82N_0	A18
0	IO_L82P_0	B18
0	IO_L83N_0	H19
0	IO_L83P_0	H18
0	IO_L84N_0	C20
0	IO_L84P_0	C21
0	IO_L91N_0/VREF_0	D19

Table 80: CF1144 CGA — XQ2V6000

Bank	Pin Description	Pin Number
0	IO_L91P_0	D18
0	IO_L92N_0	G18
0	IO_L92P_0	G19
0	IO_L93N_0	F18
0	IO_L93P_0	F19
0	IO_L94N_0/VREF_0	C19
0	IO_L94P_0	C18
0	IO_L95N_0/GCLK7P	K18
0	IO_L95P_0/GCLK6S	J18
0	IO_L96N_0/GCLK5P	E19
0	IO_L96P_0/GCLK4S	E18
1	IO_L96N_1/GCLK3P	E17
1	IO_L96P_1/GCLK2S	E16
1	IO_L95N_1/GCLK1P	H17
1	IO_L95P_1/GCLK0S	H16
1	IO_L94N_1	D17
1	IO_L94P_1/VREF_1	D16
1	IO_L93N_1	F16
1	IO_L93P_1	F17
1	IO_L92N_1	G16
1	IO_L92P_1	G17
1	IO_L91N_1	C16
1	IO_L91P_1/VREF_1	C15
1	IO_L84N_1	D14
1	IO_L84P_1	D15
1	IO_L83N_1	J17
1	IO_L83P_1	K17
1	IO_L82N_1	B17
1	IO_L82P_1	A17
1	IO_L81N_1/VREF_1	A15
1	IO_L81P_1	B16
1	IO_L80N_1	L17
1	IO_L80P_1	L16
1	IO_L79N_1	A13

Table 80: CF1144 CGA — XQ2V6000

Bank	Pin Description	Pin Number
1	IO_L79P_1	A14
1	IO_L78N_1	C13
1	IO_L78P_1	C14
1	IO_L77N_1	K16
1	IO_L77P_1	K15
1	IO_L76N_1	B13
1	IO_L76P_1	B14
1	IO_L75N_1/VREF_1	F15
1	IO_L75P_1	G15
1	IO_L74N_1	H15
1	IO_L74P_1	H14
1	IO_L73N_1	A11
1	IO_L73P_1	A12
1	IO_L72N_1	E13
1	IO_L72P_1	E14
1	IO_L71N_1	J15
1	IO_L71P_1	J14
1	IO_L70N_1	D12
1	IO_L70P_1	D13
1	IO_L69N_1/VREF_1	F14
1	IO_L69P_1	F13
1	IO_L68N_1	C11
1	IO_L68P_1	C12
1	IO_L67N_1	B11
1	IO_L67P_1	B12
1	IO_L60N_1	F11
1	IO_L60P_1	F12
1	IO_L54N_1	D10
1	IO_L54P_1	D11
1	IO_L53N_1	G12
1	IO_L53P_1	G13
1	IO_L52N_1	B9
1	IO_L52P_1	B10
1	IO_L51N_1/VREF_1	B8
1	IO_L51P_1	A9

Table 80: CF1144 CGA — XQ2V6000

Bank	Pin Description	Pin Number
1	IO_L50N_1	K14
1	IO_L50P_1	K13
1	IO_L49N_1	A6
1	IO_L49P_1	A7
1	IO_L30N_1	D9
1	IO_L30P_1	C9
1	IO_L29N_1	H13
1	IO_L29P_1	H12
1	IO_L28N_1	C7
1	IO_L28P_1	C8
1	IO_L27N_1/VREF_1	E11
1	IO_L27P_1	E10
1	IO_L26N_1	J13
1	IO_L26P_1	K12
1	IO_L25N_1	B6
1	IO_L25P_1	B7
1	IO_L24N_1	E8
1	IO_L24P_1	E9
1	IO_L23N_1	G10
1	IO_L23P_1	G11
1	IO_L22N_1	A4
1	IO_L22P_1	A5
1	IO_L21N_1/VREF_1	F10
1	IO_L21P_1	G9
1	IO_L20N_1	J12
1	IO_L20P_1	J11
1	IO_L19N_1	B4
1	IO_L19P_1	B5
1	IO_L06N_1	D6
1	IO_L06P_1	C6
1	IO_L05N_1	H11
1	IO_L05P_1	J10
1	IO_L04N_1	D8
1	IO_L04P_1/VREF_1	E7
1	IO_L03N_1/VRP_1	F9

Table 80: CF1144 CGA — XQ2V6000

Bank	Pin Description	Pin Number
1	IO_L03P_1/VRN_1	F8
1	IO_L02N_1	H10
1	IO_L02P_1	H9
1	IO_L01N_1	C2
1	IO_L01P_1	B3
2	IO_L01N_2	E2
2	IO_L01P_2	D2
2	IO_L02N_2/VRP_2	K11
2	IO_L02P_2/VRN_2	K10
2	IO_L03N_2	F5
2	IO_L03P_2/VREF_2	G5
2	IO_L04N_2	E3
2	IO_L04P_2	D3
2	IO_L05N_2	J9
2	IO_L05P_2	K9
2	IO_L06N_2	F4
2	IO_L06P_2	E4
2	IO_L19N_2	E1
2	IO_L19P_2	D1
2	IO_L20N_2	J8
2	IO_L20P_2	K8
2	IO_L21N_2	H7
2	IO_L21P_2/VREF_2	J7
2	IO_L22N_2	H6
2	IO_L22P_2	G6
2	IO_L23N_2	L10
2	IO_L23P_2	L9
2	IO_L24N_2	G3
2	IO_L24P_2	F3
2	IO_L25N_2	G2
2	IO_L25P_2	F2
2	IO_L26N_2	M10
2	IO_L26P_2	N10
2	IO_L27N_2	J6

Table 80: CF1144 CGA — XQ2V6000

Bank	Pin Description	Pin Number
2	IO_L27P_2/VREF_2	K6
2	IO_L28N_2	J5
2	IO_L28P_2	H5
2	IO_L29N_2	L7
2	IO_L29P_2	K7
2	IO_L30N_2	J4
2	IO_L30P_2	H4
2	IO_L43N_2	G1
2	IO_L43P_2	F1
2	IO_L44N_2	L8
2	IO_L44P_2	M8
2	IO_L45N_2	J1
2	IO_L45P_2/VREF_2	H2
2	IO_L46N_2	J3
2	IO_L46P_2	H3
2	IO_L47N_2	M9
2	IO_L47P_2	N9
2	IO_L48N_2	L5
2	IO_L48P_2	K5
2	IO_L49N_2	K2
2	IO_L49P_2	J2
2	IO_L50N_2	N7
2	IO_L50P_2	M7
2	IO_L51N_2	L6
2	IO_L51P_2/VREF_2	M6
2	IO_L52N_2	M3
2	IO_L52P_2	L3
2	IO_L53N_2	L4
2	IO_L53P_2	K4
2	IO_L54N_2	N4
2	IO_L54P_2	M4
2	IO_L67N_2	M2
2	IO_L67P_2	L2
2	IO_L68N_2	N8
2	IO_L68P_2	P8

Table 80: CF1144 CGA — XQ2V6000

Bank	Pin Description	Pin Number
2	IO_L69N_2	N6
2	IO_L69P_2/VREF_2	P6
2	IO_L70N_2	P5
2	IO_L70P_2	N5
2	IO_L71N_2	P10
2	IO_L71P_2	R10
2	IO_L72N_2	P3
2	IO_L72P_2	N3
2	IO_L73N_2	M1
2	IO_L73P_2	L1
2	IO_L74N_2	P9
2	IO_L74P_2	R9
2	IO_L75N_2	P2
2	IO_L75P_2/VREF_2	N2
2	IO_L76N_2	R4
2	IO_L76P_2	P4
2	IO_L77N_2	R8
2	IO_L77P_2	T8
2	IO_L78N_2	T3
2	IO_L78P_2	R3
2	IO_L79N_2	P1
2	IO_L79P_2	N1
2	IO_L80N_2	T11
2	IO_L80P_2	U11
2	IO_L81N_2	R7
2	IO_L81P_2/VREF_2	R6
2	IO_L82N_2	U5
2	IO_L82P_2	T5
2	IO_L83N_2	T10
2	IO_L83P_2	U10
2	IO_L84N_2	U4
2	IO_L84P_2	T4
2	IO_L91N_2	T2
2	IO_L91P_2	R1
2	IO_L92N_2	U7

Table 80: CF1144 CGA — XQ2V6000

Bank	Pin Description	Pin Number
2	IO_L92P_2	T7
2	IO_L93N_2	T6
2	IO_L93P_2/VREF_2	U6
2	IO_L94N_2	U1
2	IO_L94P_2	U2
2	IO_L95N_2	U9
2	IO_L95P_2	U8
2	IO_L96N_2	U3
2	IO_L96P_2	V4
3	IO_L96N_3	V6
3	IO_L96P_3	W6
3	IO_L95N_3	V5
3	IO_L95P_3	W5
3	IO_L94N_3	V7
3	IO_L94P_3	W7
3	IO_L93N_3/VREF_3	V10
3	IO_L93P_3	W10
3	IO_L92N_3	V1
3	IO_L92P_3	V2
3	IO_L91N_3	W3
3	IO_L91P_3	Y3
3	IO_L84N_3	V9
3	IO_L84P_3	V8
3	IO_L83N_3	W4
3	IO_L83P_3	Y4
3	IO_L82N_3	W11
3	IO_L82P_3	V11
3	IO_L81N_3/VREF_3	W8
3	IO_L81P_3	Y8
3	IO_L80N_3	W2
3	IO_L80P_3	Y1
3	IO_L79N_3	AA3
3	IO_L79P_3	AB3
3	IO_L78N_3	Y6

Table 80: CF1144 CGA — XQ2V6000

Bank	Pin Description	Pin Number
3	IO_L78P_3	AA6
3	IO_L77N_3	AA4
3	IO_L77P_3	AB4
3	IO_L76N_3	Y7
3	IO_L76P_3	AA8
3	IO_L75N_3/VREF_3	Y10
3	IO_L75P_3	AA10
3	IO_L74N_3	AA1
3	IO_L74P_3	AB1
3	IO_L73N_3	AA5
3	IO_L73P_3	AB5
3	IO_L72N_3	AA9
3	IO_L72P_3	Y9
3	IO_L71N_3	AA2
3	IO_L71P_3	AB2
3	IO_L70N_3	AB6
3	IO_L70P_3	AC6
3	IO_L69N_3/VREF_3	AD1
3	IO_L69P_3	AC1
3	IO_L68N_3	AC3
3	IO_L68P_3	AD3
3	IO_L67N_3	AC4
3	IO_L67P_3	AD4
3	IO_L54N_3	AB7
3	IO_L54P_3	AC7
3	IO_L53N_3	AC2
3	IO_L53P_3	AD2
3	IO_L52N_3	AC8
3	IO_L52P_3	AB8
3	IO_L51N_3/VREF_3	AB10
3	IO_L51P_3	AC10
3	IO_L50N_3	AD5
3	IO_L50P_3	AE5
3	IO_L49N_3	AE4
3	IO_L49P_3	AF4

Table 80: CF1144 CGA — XQ2V6000

Bank	Pin Description	Pin Number
3	IO_L48N_3	AB9
3	IO_L48P_3	AC9
3	IO_L47N_3	AE2
3	IO_L47P_3	AF1
3	IO_L46N_3	AD6
3	IO_L46P_3	AE6
3	IO_L45N_3/VREF_3	AD9
3	IO_L45P_3	AE9
3	IO_L44N_3	AF2
3	IO_L44P_3	AG2
3	IO_L43N_3	AF3
3	IO_L43P_3	AG3
3	IO_L30N_3	AD7
3	IO_L30P_3	AE7
3	IO_L29N_3	AF5
3	IO_L29P_3	AG5
3	IO_L28N_3	AE8
3	IO_L28P_3	AD8
3	IO_L27N_3/VREF_3	AF8
3	IO_L27P_3	AF9
3	IO_L26N_3	AH1
3	IO_L26P_3	AJ1
3	IO_L25N_3	AG4
3	IO_L25P_3	AH5
3	IO_L24N_3	AF6
3	IO_L24P_3	AG6
3	IO_L23N_3	AH3
3	IO_L23P_3	AJ3
3	IO_L22N_3	AF7
3	IO_L22P_3	AG7
3	IO_L21N_3/VREF_3	AL1
3	IO_L21P_3	AK1
3	IO_L20N_3	AH2
3	IO_L20P_3	AJ2
3	IO_L19N_3	AJ4

Table 80: CF1144 CGA — XQ2V6000

Bank	Pin Description	Pin Number
3	IO_L19P_3	AK4
3	IO_L06N_3	AE10
3	IO_L06P_3	AD10
3	IO_L05N_3	AK2
3	IO_L05P_3	AL2
3	IO_L04N_3	AH6
3	IO_L04P_3	AJ5
3	IO_L03N_3/VREF_3	AE11
3	IO_L03P_3	AF11
3	IO_L02N_3/VRP_3	AK3
3	IO_L02P_3/VRN_3	AL3
3	IO_L01N_3	AF10
3	IO_L01P_3	AG9
4	IO_L01N_4/DOUT	AM4
4	IO_L01P_4/INIT_B	AL5
4	IO_L02N_4/D0	AG10
4	IO_L02P_4/D1	AH11
4	IO_L03N_4/D2/ALT_VRP_4	AK7
4	IO_L03P_4/D3/ALT_VRN_4	AK8
4	IO_L04N_4/VREF_4	AL6
4	IO_L04P_4	AM6
4	IO_L05N_4/VRP_4	AK9
4	IO_L05P_4/VRN_4	AJ8
4	IO_L06N_4	AM8
4	IO_L06P_4	AM7
4	IO_L19N_4	AN3
4	IO_L19P_4	AM2
4	IO_L20N_4	AJ10
4	IO_L20P_4	AJ9
4	IO_L21N_4	AH9
4	IO_L21P_4/VREF_4	AH10
4	IO_L22N_4	AN5
4	IO_L22P_4	AN4
4	IO_L23N_4	AE12

Table 80: CF1144 CGA — XQ2V6000

Bank	Pin Description	Pin Number
4	IO_L23P_4	AE13
4	IO_L24N_4	AM9
4	IO_L24P_4	AL8
4	IO_L25N_4	AP5
4	IO_L25P_4	AP4
4	IO_L26N_4	AG11
4	IO_L26P_4	AG12
4	IO_L27N_4	AN7
4	IO_L27P_4/VREF_4	AN6
4	IO_L28N_4	AL10
4	IO_L28P_4	AL9
4	IO_L29N_4	AF12
4	IO_L29P_4	AF13
4	IO_L30N_4	AK10
4	IO_L30P_4	AK11
4	IO_L49N_4	AP7
4	IO_L49P_4	AP6
4	IO_L50N_4	AH13
4	IO_L50P_4	AH12
4	IO_L51N_4	AJ11
4	IO_L51P_4/VREF_4	AJ12
4	IO_L52N_4	AP9
4	IO_L52P_4	AN8
4	IO_L53N_4	AG13
4	IO_L53P_4	AG14
4	IO_L54N_4	AM11
4	IO_L54P_4	AL11
4	IO_L60N_4	AN10
4	IO_L60P_4	AN9
4	IO_L67N_4	AN12
4	IO_L67P_4	AN11
4	IO_L68N_4	AE14
4	IO_L68P_4	AE15
4	IO_L69N_4	AJ13
4	IO_L69P_4/VREF_4	AJ14

Table 80: CF1144 CGA — XQ2V6000

Bank	Pin Description	Pin Number
4	IO_L70N_4	AL13
4	IO_L70P_4	AL12
4	IO_L71N_4	AF14
4	IO_L71P_4	AF15
4	IO_L72N_4	AM13
4	IO_L72P_4	AM12
4	IO_L73N_4	AP12
4	IO_L73P_4	AP11
4	IO_L74N_4	AG15
4	IO_L74P_4	AG16
4	IO_L75N_4	AN14
4	IO_L75P_4/VREF_4	AN13
4	IO_L76N_4	AP14
4	IO_L76P_4	AP13
4	IO_L77N_4	AD16
4	IO_L77P_4	AD17
4	IO_L78N_4	AK14
4	IO_L78P_4	AK13
4	IO_L79N_4	AN16
4	IO_L79P_4	AP15
4	IO_L80N_4	AE16
4	IO_L80P_4	AE17
4	IO_L81N_4	AH15
4	IO_L81P_4/VREF_4	AJ15
4	IO_L82N_4	AP17
4	IO_L82P_4	AN17
4	IO_L83N_4	AH17
4	IO_L83P_4	AH16
4	IO_L84N_4	AL15
4	IO_L84P_4	AL14
4	IO_L91N_4/VREF_4	AL16
4	IO_L91P_4	AL17
4	IO_L92N_4	AJ17
4	IO_L92P_4	AJ16
4	IO_L93N_4	AM15

Table 80: CF1144 CGA — XQ2V6000

Bank	Pin Description	Pin Number
4	IO_L93P_4	AM14
4	IO_L94N_4/VREF_4	AM16
4	IO_L94P_4	AM17
4	IO_L95N_4/GCLK3S	AF17
4	IO_L95P_4/GCLK2P	AG17
4	IO_L96N_4/GCLK1S	AK16
4	IO_L96P_4/GCLK0P	AK17
5	IO_L96N_5/GCLK7S	AK18
5	IO_L96P_5/GCLK6P	AK19
5	IO_L95N_5/GCLK5S	AG18
5	IO_L95P_5/GCLK4P	AF18
5	IO_L94N_5	AL18
5	IO_L94P_5/VREF_5	AL19
5	IO_L93N_5	AJ19
5	IO_L93P_5	AJ18
5	IO_L92N_5	AH19
5	IO_L92P_5	AH18
5	IO_L91N_5	AM19
5	IO_L91P_5/VREF_5	AM20
5	IO_L84N_5	AL21
5	IO_L84P_5	AL20
5	IO_L83N_5	AM22
5	IO_L83P_5	AM21
5	IO_L82N_5	AN18
5	IO_L82P_5	AP18
5	IO_L81N_5/VREF_5	AP20
5	IO_L81P_5	AN19
5	IO_L80N_5	AE18
5	IO_L80P_5	AE19
5	IO_L79N_5	AP22
5	IO_L79P_5	AP21
5	IO_L78N_5	AK22
5	IO_L78P_5	AK21
5	IO_L77N_5	AD18

Table 80: CF1144 CGA — XQ2V6000

Bank	Pin Description	Pin Number
5	IO_L77P_5	AD19
5	IO_L76N_5	AN22
5	IO_L76P_5	AN21
5	IO_L75N_5/VREF_5	AJ20
5	IO_L75P_5	AH20
5	IO_L74N_5	AG19
5	IO_L74P_5	AG20
5	IO_L73N_5	AP24
5	IO_L73P_5	AP23
5	IO_L72N_5	AL23
5	IO_L72P_5	AL22
5	IO_L71N_5	AF20
5	IO_L71P_5	AF21
5	IO_L70N_5	AM24
5	IO_L70P_5	AM23
5	IO_L69N_5/VREF_5	AJ21
5	IO_L69P_5	AJ22
5	IO_L68N_5	AJ24
5	IO_L68P_5	AJ23
5	IO_L67N_5	AN24
5	IO_L67P_5	AN23
5	IO_L60N_5	AN26
5	IO_L60P_5	AN25
5	IO_L54N_5	AL25
5	IO_L54P_5	AL24
5	IO_L53N_5	AE20
5	IO_L53P_5	AE21
5	IO_L52N_5	AN27
5	IO_L52P_5	AP26
5	IO_L51N_5/VREF_5	AP29
5	IO_L51P_5	AP28
5	IO_L50N_5	AG21
5	IO_L50P_5	AG22
5	IO_L49N_5	AN29
5	IO_L49P_5	AN28

Table 80: CF1144 CGA — XQ2V6000

Bank	Pin Description	Pin Number
5	IO_L30N_5	AK24
5	IO_L30P_5	AK25
5	IO_L29N_5	AH23
5	IO_L29P_5	AH22
5	IO_L28N_5	AP31
5	IO_L28P_5	AP30
5	IO_L27N_5/VREF_5	AH24
5	IO_L27P_5	AH25
5	IO_L26N_5	AF22
5	IO_L26P_5	AF23
5	IO_L25N_5	AM27
5	IO_L25P_5	AM26
5	IO_L24N_5	AL27
5	IO_L24P_5	AL26
5	IO_L23N_5	AH26
5	IO_L23P_5	AJ25
5	IO_L22N_5	AN31
5	IO_L22P_5	AN30
5	IO_L21N_5/VREF_5	AK26
5	IO_L21P_5	AK27
5	IO_L20N_5	AG23
5	IO_L20P_5	AF24
5	IO_L19N_5	AM33
5	IO_L19P_5	AN32
5	IO_L06N_5	AJ27
5	IO_L06P_5	AJ26
5	IO_L05N_5/VRP_5	AE22
5	IO_L05P_5/VRN_5	AE23
5	IO_L04N_5	AM28
5	IO_L04P_5/VREF_5	AM29
5	IO_L03N_5/D4/ALT_VRP_5	AK28
5	IO_L03P_5/D5/ALT_VRN_5	AL29
5	IO_L02N_5/D6	AG24
5	IO_L02P_5/D7	AG25
5	IO_L01N_5/RDWR_B	AL30

Table 80: CF1144 CGA — XQ2V6000

Bank	Pin Description	Pin Number
5	IO_L01P_5/CS_B	AM31
6	IO_L01P_6	AE24
6	IO_L01N_6	AD25
6	IO_L02P_6/VRN_6	AJ30
6	IO_L02N_6/VRP_6	AH30
6	IO_L03P_6	AL32
6	IO_L03N_6/VREF_6	AK32
6	IO_L04P_6	AF25
6	IO_L04N_6	AE25
6	IO_L05P_6	AJ31
6	IO_L05N_6	AK31
6	IO_L06P_6	AH29
6	IO_L06N_6	AG29
6	IO_L19P_6	AG26
6	IO_L19N_6	AF26
6	IO_L20P_6	AL33
6	IO_L20N_6	AK33
6	IO_L21P_6	AJ32
6	IO_L21N_6/VREF_6	AH32
6	IO_L22P_6	AG28
6	IO_L22N_6	AF28
6	IO_L23P_6	AG30
6	IO_L23N_6	AF30
6	IO_L24P_6	AF29
6	IO_L24N_6	AE29
6	IO_L25P_6	AF27
6	IO_L25N_6	AE27
6	IO_L26P_6	AL34
6	IO_L26N_6	AK34
6	IO_L27P_6	AE28
6	IO_L27N_6/VREF_6	AD28
6	IO_L28P_6	AE26
6	IO_L28N_6	AD26
6	IO_L29P_6	AF31

Table 80: CF1144 CGA — XQ2V6000

Bank	Pin Description	Pin Number
6	IO_L29N_6	AG31
6	IO_L30P_6	AF32
6	IO_L30N_6	AG32
6	IO_L43P_6	AC25
6	IO_L43N_6	AB25
6	IO_L44P_6	AJ33
6	IO_L44N_6	AH33
6	IO_L45P_6	AE31
6	IO_L45N_6/VREF_6	AD32
6	IO_L46P_6	AD27
6	IO_L46N_6	AC27
6	IO_L47P_6	AJ34
6	IO_L47N_6	AH34
6	IO_L48P_6	AE30
6	IO_L48N_6	AD30
6	IO_L49P_6	AC26
6	IO_L49N_6	AB26
6	IO_L50P_6	AD29
6	IO_L50N_6	AC29
6	IO_L51P_6	AF33
6	IO_L51N_6/VREF_6	AG33
6	IO_L52P_6	AC28
6	IO_L52N_6	AB28
6	IO_L53P_6	AF34
6	IO_L53N_6	AE33
6	IO_L54P_6	AB27
6	IO_L54N_6	AA27
6	IO_L67P_6	AA25
6	IO_L67N_6	Y25
6	IO_L68P_6	AD33
6	IO_L68N_6	AC33
6	IO_L69P_6	AC32
6	IO_L69N_6/VREF_6	AB32
6	IO_L70P_6	AA26
6	IO_L70N_6	Y26

Table 80: CF1144 CGA — XQ2V6000

Bank	Pin Description	Pin Number
6	IO_L71P_6	AD34
6	IO_L71N_6	AC34
6	IO_L72P_6	AC31
6	IO_L72N_6	AD31
6	IO_L73P_6	Y27
6	IO_L73N_6	W27
6	IO_L74P_6	AB29
6	IO_L74N_6	AA29
6	IO_L75P_6	AB31
6	IO_L75N_6/VREF_6	AA31
6	IO_L76P_6	Y28
6	IO_L76N_6	Y29
6	IO_L77P_6	AB33
6	IO_L77N_6	AA33
6	IO_L78P_6	AA30
6	IO_L78N_6	AB30
6	IO_L79P_6	W24
6	IO_L79N_6	V24
6	IO_L80P_6	AB34
6	IO_L80N_6	AA34
6	IO_L81P_6	W33
6	IO_L81N_6/VREF_6	Y34
6	IO_L82P_6	W25
6	IO_L82N_6	V25
6	IO_L83P_6	Y32
6	IO_L83N_6	AA32
6	IO_L84P_6	W29
6	IO_L84N_6	V29
6	IO_L91P_6	W28
6	IO_L91N_6	V28
6	IO_L92P_6	V33
6	IO_L92N_6	V34
6	IO_L93P_6	Y31
6	IO_L93N_6/VREF_6	W31
6	IO_L94P_6	V26

Table 80: CF1144 CGA — XQ2V6000

Bank	Pin Description	Pin Number
6	IO_L94N_6	V27
6	IO_L95P_6	W30
6	IO_L95N_6	V30
6	IO_L96P_6	V32
6	IO_L96N_6	W32
7	IO_L96P_7	U31
7	IO_L96N_7	V31
7	IO_L95P_7	T28
7	IO_L95N_7	U28
7	IO_L94P_7	U33
7	IO_L94N_7	U34
7	IO_L93P_7/VREF_7	U29
7	IO_L93N_7	T29
7	IO_L92P_7	U27
7	IO_L92N_7	U26
7	IO_L91P_7	T30
7	IO_L91N_7	U30
7	IO_L84P_7	R32
7	IO_L84N_7	T32
7	IO_L83P_7	U25
7	IO_L83N_7	T25
7	IO_L82P_7	R34
7	IO_L82N_7	T33
7	IO_L81P_7/VREF_7	N34
7	IO_L81N_7	P34
7	IO_L80P_7	U24
7	IO_L80N_7	T24
7	IO_L79P_7	R31
7	IO_L79N_7	T31
7	IO_L78P_7	N32
7	IO_L78N_7	P32
7	IO_L77P_7	T27
7	IO_L77N_7	R27
7	IO_L76P_7	N33

Table 80: CF1144 CGA — XQ2V6000

Bank	Pin Description	Pin Number
7	IO_L76N_7	P33
7	IO_L75P_7/VREF_7	R29
7	IO_L75N_7	R28
7	IO_L74P_7	R26
7	IO_L74N_7	P26
7	IO_L73P_7	N31
7	IO_L73N_7	P31
7	IO_L72P_7	N30
7	IO_L72N_7	P30
7	IO_L71P_7	R25
7	IO_L71N_7	P25
7	IO_L70P_7	L34
7	IO_L70N_7	M34
7	IO_L69P_7/VREF_7	P29
7	IO_L69N_7	N29
7	IO_L68P_7	P27
7	IO_L68N_7	N27
7	IO_L67P_7	L32
7	IO_L67N_7	M32
7	IO_L54P_7	L31
7	IO_L54N_7	M31
7	IO_L53P_7	K29
7	IO_L53N_7	L30
7	IO_L52P_7	L33
7	IO_L52N_7	M33
7	IO_L51P_7/VREF_7	M29
7	IO_L51N_7	L29
7	IO_L50P_7	M28
7	IO_L50N_7	N28
7	IO_L49P_7	K30
7	IO_L49N_7	K31
7	IO_L48P_7	H32
7	IO_L48N_7	J32
7	IO_L47P_7	N26
7	IO_L47N_7	M26

Table 80: CF1144 CGA — XQ2V6000

Bank	Pin Description	Pin Number
7	IO_L46P_7	J33
7	IO_L46N_7	K33
7	IO_L45P_7/VREF_7	H33
7	IO_L45N_7	J34
7	IO_L44P_7	M27
7	IO_L44N_7	L27
7	IO_L43P_7	H31
7	IO_L43N_7	J31
7	IO_L30P_7	F32
7	IO_L30N_7	G32
7	IO_L29P_7	N25
7	IO_L29N_7	M25
7	IO_L28P_7	F34
7	IO_L28N_7	G34
7	IO_L27P_7/VREF_7	J30
7	IO_L27N_7	H30
7	IO_L26P_7	K28
7	IO_L26N_7	L28
7	IO_L25P_7	H28
7	IO_L25N_7	J29
7	IO_L24P_7	G29
7	IO_L24N_7	H29
7	IO_L23P_7	L26
7	IO_L23N_7	K26
7	IO_L22P_7	F33
7	IO_L22N_7	G33
7	IO_L21P_7/VREF_7	J28
7	IO_L21N_7	J27
7	IO_L20P_7	K27
7	IO_L20N_7	J26
7	IO_L19P_7	E31
7	IO_L19N_7	F31
7	IO_L06P_7	D32
7	IO_L06N_7	E32
7	IO_L05P_7	L25

Table 80: CF1144 CGA — XQ2V6000

Bank	Pin Description	Pin Number
7	IO_L05N_7	K24
7	IO_L04P_7	D34
7	IO_L04N_7	E34
7	IO_L03P_7/VREF_7	G30
7	IO_L03N_7	F30
7	IO_L02P_7/VRN_7	K25
7	IO_L02N_7/VRP_7	J25
7	IO_L01P_7	D33
7	IO_L01N_7	E33
0	VCCO_0	M22
0	VCCO_0	M21
0	VCCO_0	M20
0	VCCO_0	M19
0	VCCO_0	M18
0	VCCO_0	L23
0	VCCO_0	L22
0	VCCO_0	L21
0	VCCO_0	L20
0	VCCO_0	E20
0	VCCO_0	D28
0	VCCO_0	A25
0	VCCO_0	A19
1	VCCO_1	M17
1	VCCO_1	M16
1	VCCO_1	M15
1	VCCO_1	M14
1	VCCO_1	M13
1	VCCO_1	L15
1	VCCO_1	L14
1	VCCO_1	L13
1	VCCO_1	L12
1	VCCO_1	E15
1	VCCO_1	D7
1	VCCO_1	A16

Table 80: CF1144 CGA — XQ2V6000

Bank	Pin Description	Pin Number
1	VCCO_1	A10
2	VCCO_2	U12
2	VCCO_2	T12
2	VCCO_2	T1
2	VCCO_2	R12
2	VCCO_2	R11
2	VCCO_2	R5
2	VCCO_2	P12
2	VCCO_2	P11
2	VCCO_2	N12
2	VCCO_2	N11
2	VCCO_2	M11
2	VCCO_2	K1
2	VCCO_2	G4
3	VCCO_3	AH4
3	VCCO_3	AE1
3	VCCO_3	AC11
3	VCCO_3	AB12
3	VCCO_3	AB11
3	VCCO_3	AA12
3	VCCO_3	AA11
3	VCCO_3	Y12
3	VCCO_3	Y11
3	VCCO_3	Y5
3	VCCO_3	W12
3	VCCO_3	W1
3	VCCO_3	V12
4	VCCO_4	AP16
4	VCCO_4	AP10
4	VCCO_4	AL7
4	VCCO_4	AK15
4	VCCO_4	AD15
4	VCCO_4	AD14
4	VCCO_4	AD13
4	VCCO_4	AD12

Table 80: CF1144 CGA — XQ2V6000

Bank	Pin Description	Pin Number
4	VCCO_4	AC17
4	VCCO_4	AC16
4	VCCO_4	AC15
4	VCCO_4	AC14
4	VCCO_4	AC13
5	VCCO_5	AP25
5	VCCO_5	AP19
5	VCCO_5	AL28
5	VCCO_5	AK20
5	VCCO_5	AD23
5	VCCO_5	AD22
5	VCCO_5	AD21
5	VCCO_5	AD20
5	VCCO_5	AC22
5	VCCO_5	AC21
5	VCCO_5	AC20
5	VCCO_5	AC19
5	VCCO_5	AC18
6	VCCO_6	AH31
6	VCCO_6	AE34
6	VCCO_6	AC24
6	VCCO_6	AB24
6	VCCO_6	AB23
6	VCCO_6	AA24
6	VCCO_6	AA23
6	VCCO_6	Y30
6	VCCO_6	Y24
6	VCCO_6	Y23
6	VCCO_6	W34
6	VCCO_6	W23
6	VCCO_6	V23
7	VCCO_7	U23
7	VCCO_7	T34
7	VCCO_7	T23
7	VCCO_7	R30

Table 80: CF1144 CGA — XQ2V6000

Bank	Pin Description	Pin Number
7	VCCO_7	R24
7	VCCO_7	R23
7	VCCO_7	P24
7	VCCO_7	P23
7	VCCO_7	N24
7	VCCO_7	N23
7	VCCO_7	M24
7	VCCO_7	K34
7	VCCO_7	G31
NA	CCLK	AH8
NA	PROG_B	D30
NA	DONE	AJ7
NA	M0	AH27
NA	M1	AJ28
NA	M2	AK29
NA	HSWAP_EN	E29
NA	TCK	F7
NA	TDI	C31
NA	TDO	D5
NA	TMS	E6
NA	PWRDWN_B	AK6
NA	DXN	F28
NA	DXP	G27
NA	VBATT	C4
NA	RSVD	G8
NA	VCCAUX	AM30
NA	VCCAUX	AM18
NA	VCCAUX	AM5
NA	VCCAUX	V3
NA	VCCAUX	U32
NA	VCCAUX	C30
NA	VCCAUX	C17
NA	VCCAUX	C5
NA	VCCINT	AD24

Table 80: CF1144 CGA — XQ2V6000

Bank	Pin Description	Pin Number
NA	VCCINT	AD11
NA	VCCINT	AC23
NA	VCCINT	AC12
NA	VCCINT	AB22
NA	VCCINT	AB21
NA	VCCINT	AB20
NA	VCCINT	AB19
NA	VCCINT	AB18
NA	VCCINT	AB17
NA	VCCINT	AB16
NA	VCCINT	AB15
NA	VCCINT	AB14
NA	VCCINT	AB13
NA	VCCINT	AA22
NA	VCCINT	AA13
NA	VCCINT	Y22
NA	VCCINT	Y13
NA	VCCINT	W22
NA	VCCINT	W13
NA	VCCINT	V22
NA	VCCINT	V13
NA	VCCINT	U22
NA	VCCINT	U13
NA	VCCINT	T22
NA	VCCINT	T13
NA	VCCINT	R22
NA	VCCINT	R13
NA	VCCINT	P22
NA	VCCINT	P13
NA	VCCINT	N22
NA	VCCINT	N21
NA	VCCINT	N20
NA	VCCINT	N19
NA	VCCINT	N18
NA	VCCINT	N17

Table 80: CF1144 CGA — XQ2V6000

Bank	Pin Description	Pin Number
NA	VCCINT	N16
NA	VCCINT	N15
NA	VCCINT	N14
NA	VCCINT	N13
NA	VCCINT	M23
NA	VCCINT	M12
NA	VCCINT	L24
NA	VCCINT	L11
NA	GND	AP32
NA	GND	AP27
NA	GND	AP8
NA	GND	AP3
NA	GND	AN33
NA	GND	AN20
NA	GND	AN15
NA	GND	AN2
NA	GND	AM34
NA	GND	AM32
NA	GND	AM25
NA	GND	AM10
NA	GND	AM3
NA	GND	AM1
NA	GND	AL31
NA	GND	AL4
NA	GND	AK30
NA	GND	AK23
NA	GND	AK12
NA	GND	AK5
NA	GND	AJ29
NA	GND	AJ6
NA	GND	AH28
NA	GND	AH21
NA	GND	AH14
NA	GND	AH7

Table 80: CF1144 CGA — XQ2V6000

Bank	Pin Description	Pin Number
NA	GND	AG34
NA	GND	AG27
NA	GND	AG8
NA	GND	AG1
NA	GND	AF19
NA	GND	AF16
NA	GND	AE32
NA	GND	AE3
NA	GND	AC30
NA	GND	AC5
NA	GND	AA28
NA	GND	AA21
NA	GND	AA20
NA	GND	AA19
NA	GND	AA18
NA	GND	AA17
NA	GND	AA16
NA	GND	AA15
NA	GND	AA14
NA	GND	AA7
NA	GND	Y33
NA	GND	Y21
NA	GND	Y20
NA	GND	Y19
NA	GND	Y18
NA	GND	Y17
NA	GND	Y16
NA	GND	Y15
NA	GND	Y14
NA	GND	Y2
NA	GND	W26
NA	GND	W21
NA	GND	W20
NA	GND	W19
NA	GND	W18

Table 80: CF1144 CGA — XQ2V6000

Bank	Pin Description	Pin Number
NA	GND	W17
NA	GND	W16
NA	GND	W15
NA	GND	W14
NA	GND	W9
NA	GND	V21
NA	GND	V20
NA	GND	V19
NA	GND	V18
NA	GND	V17
NA	GND	V16
NA	GND	V15
NA	GND	V14
NA	GND	U21
NA	GND	U20
NA	GND	U19
NA	GND	U18
NA	GND	U17
NA	GND	U16
NA	GND	U15
NA	GND	U14
NA	GND	T26
NA	GND	T21
NA	GND	T20
NA	GND	T19
NA	GND	T18
NA	GND	T17
NA	GND	T16
NA	GND	T15
NA	GND	T14
NA	GND	T9
NA	GND	R33
NA	GND	R21
NA	GND	R20
NA	GND	R19

Table 80: CF1144 CGA — XQ2V6000

Bank	Pin Description	Pin Number
NA	GND	R18
NA	GND	R17
NA	GND	R16
NA	GND	R15
NA	GND	R14
NA	GND	R2
NA	GND	P28
NA	GND	P21
NA	GND	P20
NA	GND	P19
NA	GND	P18
NA	GND	P17
NA	GND	P16
NA	GND	P15
NA	GND	P14
NA	GND	P7
NA	GND	M30
NA	GND	M5
NA	GND	K32
NA	GND	K3
NA	GND	J19
NA	GND	J16
NA	GND	H34
NA	GND	H27
NA	GND	H8
NA	GND	H1
NA	GND	G28
NA	GND	G21
NA	GND	G14
NA	GND	G7
NA	GND	F29
NA	GND	F6
NA	GND	E30
NA	GND	E23
NA	GND	E12

Table 80: CF1144 CGA — XQ2V6000

Bank	Pin Description	Pin Number
NA	GND	E5
NA	GND	D31
NA	GND	D4
NA	GND	C34
NA	GND	C32
NA	GND	C25
NA	GND	C10
NA	GND	C3
NA	GND	C1
NA	GND	B33
NA	GND	B20
NA	GND	B15
NA	GND	B2
NA	GND	A32
NA	GND	A27
NA	GND	A8
NA	GND	A3

CF1144 Ceramic Flip-Chip Fine-Pitch CGA Package Specifications (1.00mm pitch)

CF1144 WITH CAST COLUMNS

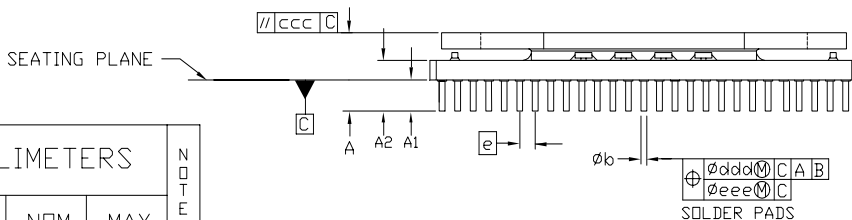
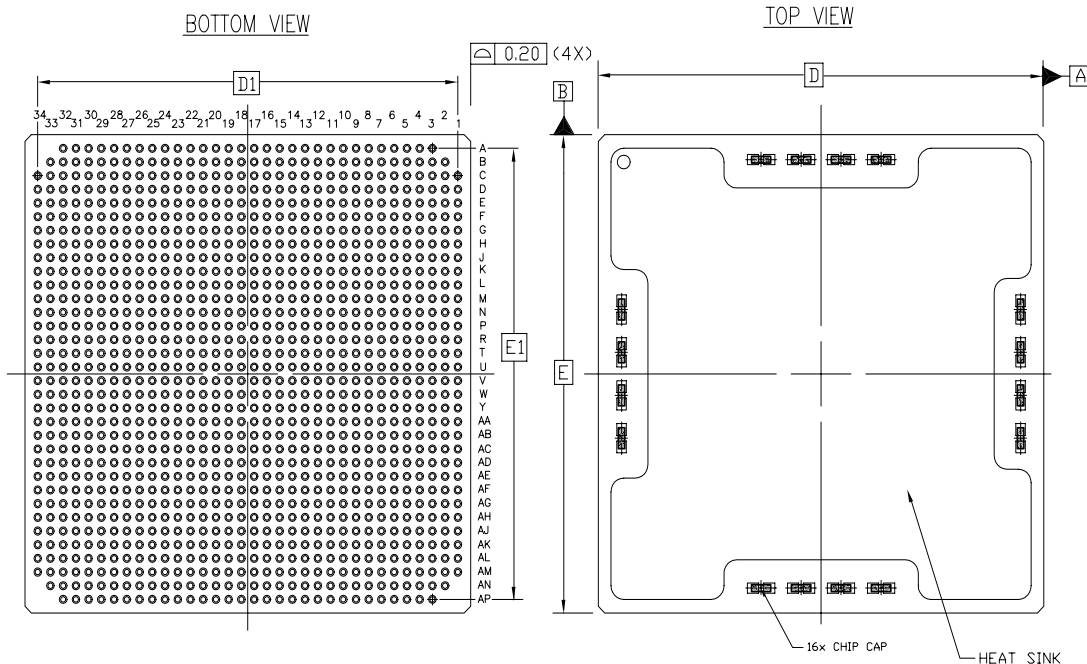

SYMBOL	MILLIMETERS			NOTE
	MIN.	NOM.	MAX.	
A	6.30	6.65	7.00	
A ₁	2.05	2.20	2.35	
A ₂	3.40	3.70	4.00	
D/E	35.00 BASIC			
D ₁ /E ₁	33.00 REF			
e	1.00 BASIC			
ϕ_b	0.51	0.54	0.57	
ccc	\sphericalangle	\sphericalangle	0.35	
ddd	\sphericalangle	\sphericalangle	0.30	
eee	\sphericalangle	\sphericalangle	0.10	
M	34			2

NOTES:

1. ALL DIMENSIONS AND TOLERANCES CONFORM TO ANSI Y14.5M-1994
2. SYMBOL 'M' IS THE BALL MATRIX SIZE.
3. CONFORMS TO JEDEC MS-034-AAR-1 (DEPOPULATED)

Figure 56: CF1144 Ceramic Flip-Chip Fine-Pitch CGA Package Specifications

Revision History

This section records the change history for this module of the data sheet.

Date	Version	Revision
9/24/03	1.0	Advance release.
01/07/04	1.1	Initial Xilinx release.