

FEATURES

- 5 Filters in one 14 Pin Package
- On Chip R/C Oscillator
- Provides 30dB of Gain

APPLICATIONS

- Graphic Equalizers
- Tape Recorders
- Receivers
- Portable Systems
- Spectrum Analyzers

GENERAL DESCRIPTION

The XR-1093A is a 5-band switched capacitor bandpass filter with peak hold outputs for use in audio applications. The 5-filters are spaced from 63Hz to 10kHz. All of the outputs provide a peak hold with slow decay time constant (330 msec) for use with most display circuits. The XR-1093A is fabricated in a low noise 3 micron

double poly-silicon CMOS process and comes in a 14 pin plastic DIP package. The nominal operating voltages are $\pm 5VDC$ (4V peak output) or $\pm 6VDC$ (5V peak output). The chip oscillator operates at 400kHz and requires only an external resistor and a capacitor.

ORDERING INFORMATION

Part No.	Package	Operating Temperature Range
XR-1093ACP	14 Lead 300 Mil PDIP	-30°C to 75°C

BLOCK DIAGRAM

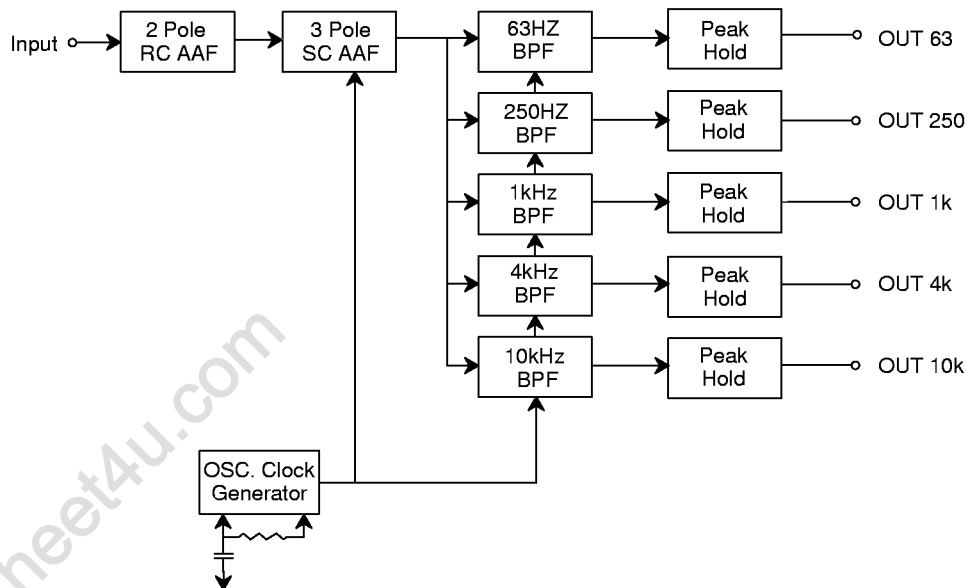
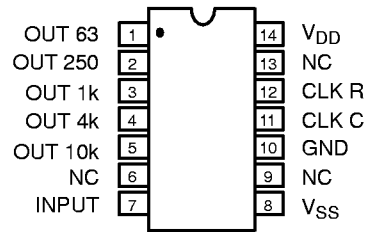

Figure 1. Internal Structure Block Diagram

PIN CONFIGURATION



14 Lead PDIP (0.300")

PIN DESCRIPTION

Pin #	Symbol	Description
1	OUT 63	Peak Hold Output of the 63Hz Filter
2	OUT 250	Peak Hold Output of the 250Hz filter
3	OUT 1k	Peak Hold Output of the 1kHz filter
4	OUT 4k	Peak Hold Output of the 4kHz filter
5	OUT 10k	Peak Hold Output of the 10kHz filter
6	NC	No Connection
7	INPUT	Device Input
8	V _{SS}	Negative Supply Voltage
9	NC	No Connection
10	GND	Ground
11	CLK C	Clock Capacitor from this Pin to GND (C _{nom} = 1nf)
12	CLK R	Clock Resistor from this Pin to CLK C (R _{nom} = 1.46kΩ)
13	NC	No Connection
14	V _{DD}	Positive Supply Voltage

ELECTRICAL CHARACTERISTICS

Test Conditions: $V_{DD} = 5V$, $V_{SS} = -5V$, $T_A = 25^\circ C$, $R = 1.46k\Omega$, $C = 1nF$

Symbol	Parameter	Min.	Typ.	Max.	Units	Conditions
General Characteristics						
V_{DD}	Positive Supply	4.75	5.0	6	V	
V_{SS}	Negative Supply	-6.0	-5.0	-4.75	V	
I_{DD}	Positive Current		8	12	mA	
I_{SS}	Negative Current		-8	-12	mA	
Oscillator Characteristics						
f_{VCO}	Clock Frequency	375	400	425	kHz	$R = 1.46k\Omega$
	Accuracy					$C = 1nF$
Output Characteristics						
V_{OS}	Output Offset	-50		150	mV	$V_{IN} = 0V$
R_O	Output Impedance		100		Ω	
C_L	Capacitive Load		30		pF	
T_D	Output Decay Time		330		mS	
Filter Characteristics						
f_o	Filter Center Frequency Variation	-5	0	+5	%	Measured at 63Hz, 250Hz, 1kHz, 4kHz, 10kHz
AV	Channel Gain	28.5	30	31.5	dB	$V_{IN} = 125mVpk$

Notes

¹ Recommended power-on sequence, V_{SS} first, followed by V_{DD} .

Specifications are subject to change without notice

ABSOLUTE MAXIMUM RATINGS

Power Supply Voltage $\pm 7V$
 Input Current $\pm 10mA$

Storage Temperature $-60^\circ C$ to $+150^\circ C$

SYSTEM DESCRIPTION

The XR-1093A generates its clocks with an internal oscillator and does not require an external clock source, thus it can be used in any application where active filters are now being used. The chip has filters spaced at 63Hz, 250Hz, 1kHz, 4kHz and 10kHz, standard frequencies in the consumer audio industry. The peak detector outputs are referenced to 0V and drive positive to be compatible

with a variety of display decoders.

The XR1093A also has an on-chip anti-alias filter that provides 30dB of rejection above 50kHz, preventing most external signals from affecting the filter performance.

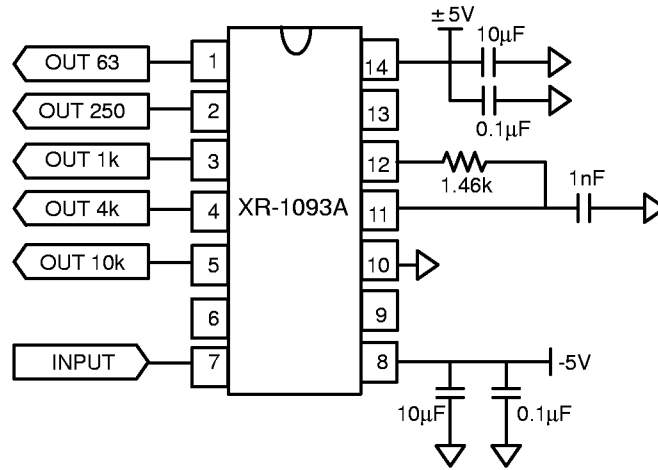

Figure 2. Typical 5-Band Application Schematic

XR-1093A I/O EQUIVALENT CIRCUITS

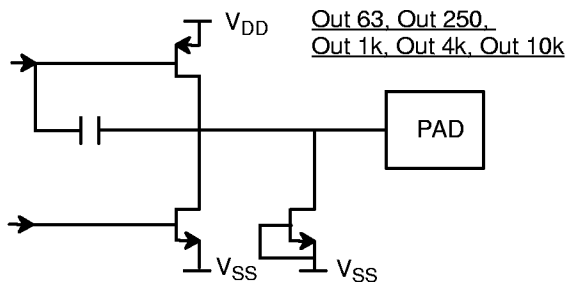

Figure 3.

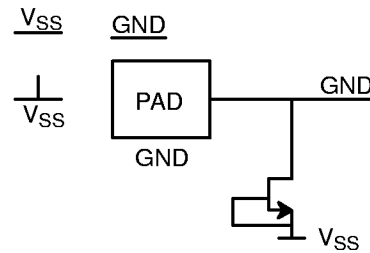

Figure 4.

XR-1093A I/O EQUIVALENT CIRCUITS (CONT'D)

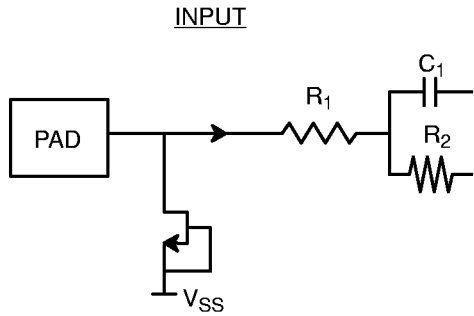

Figure 5.

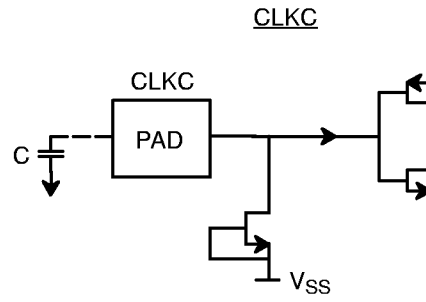

Figure 6.

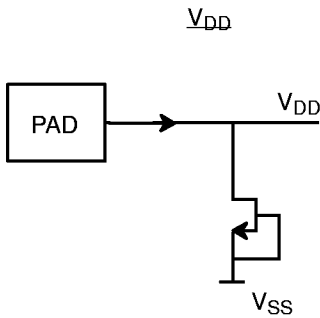

Figure 7.

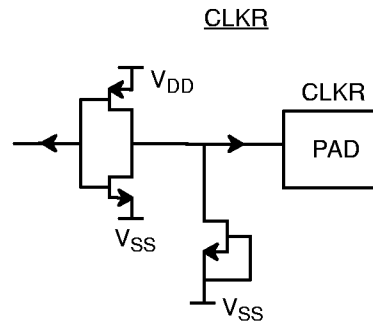
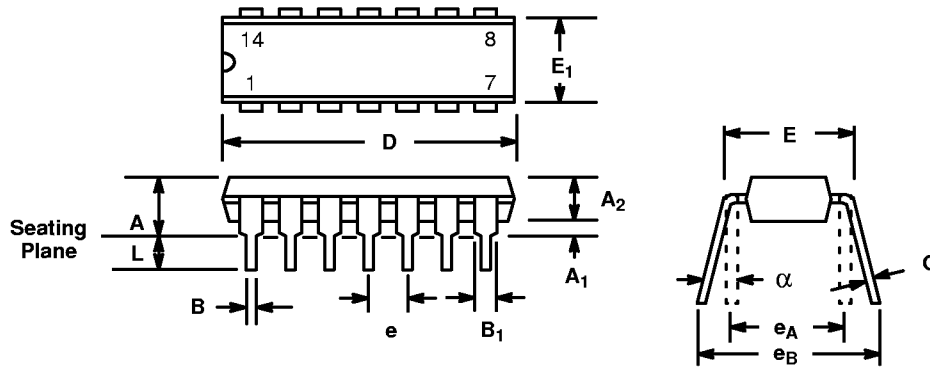

Figure 8.

14 LEAD PLASTIC DUAL-IN-LINE (300 MIL PDIP)

Rev. 1.00



SYMBOL	INCHES		MILLIMETERS	
	MIN	MAX	MIN	MAX
A	0.145	0.210	3.68	5.33
A ₁	0.015	0.070	0.38	1.78
A ₂	0.115	0.195	2.92	4.95
B	0.014	0.024	0.36	0.56
B ₁	0.030	0.070	0.76	1.78
C	0.008	0.014	0.20	0.38
D	0.725	0.795	18.42	20.19
E	0.300	0.325	7.62	8.26
E ₁	0.240	0.280	6.10	7.11
e	0.100 BSC		2.54 BSC	
e _A	0.300 BSC		7.62 BSC	
e _B	0.310	0.430	7.87	10.92
L	0.115	0.160	2.92	4.06
α	0°	15°	0°	15°

Note: The control dimension is the inch column