

Dual-Polarity Tracking Voltage Regulator

GENERAL DESCRIPTION

The XR-1468/1568 is a dual polarity tracking voltage regulator, internally trimmed for symmetrical positive and negative 15V outputs. Current output capability is 100 mA, and may be increased by adding external pass transistors. The device is intended for local "on-card" regulation, which eliminates the distribution problems associated with single point regulation.

The XR-1468CN and XR-1568N are guaranteed over the 0°C to 70°C commercial temperature range. The XR-1568M is rated over the full military temperature range of -55°C to +125°C.

FEATURES

- Internally Set for $\pm 15\text{V}$ Outputs
- $\pm 100\text{ mA}$ Peak Output Current
- Output Voltages Balanced Within 1% (XR-1568)
- 0.06% Line and Load Regulation
- Low Stand-By Current
- Output Externally Adjustable from ± 8 to ± 20 Volts
- Externally Adjustable Current Limiting
- Remote Sensing

APPLICATIONS

- Main Regulation in Small Instruments
- On-Card Regulation in Analog and Digital Systems
- Point-of-Load Precision Regulation

ABSOLUTE MAXIMUM RATINGS

Power Supply	± 30 Volts
Minimum Short-Circuit Resistance	4.0 Ohms
Load Current, Peak	± 100 mA
Power Dissipation	
Ceramic (N) Package	1.0 Watt
Derate Above +25°C	6.7 mW/°C
Operating Temperature	
XR-1568M	-55°C to +125°C
XR-1568/XR-1468C	0°C to +70°C
Storage Temperature	-65°C to +150°C

FUNCTIONAL BLOCK DIAGRAM

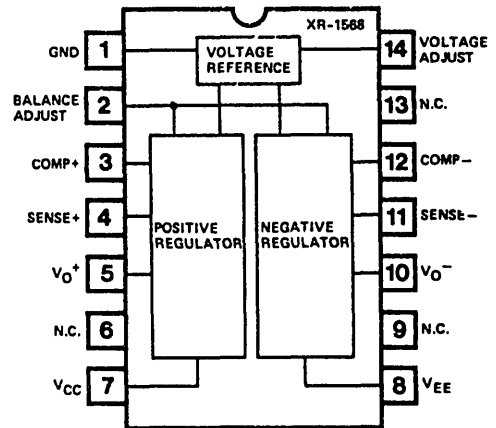

ORDERING INFORMATION

Part Number	Temperature	Output Offset	Package
XR-1568M	-55°C to +125°C	± 150 mV max	Ceramic
XR-1568N	0°C to +70°C	± 150 mV max	Ceramic
XR-1468CN	0°C to +70°C	± 300 mV max	Ceramic

SYSTEM DESCRIPTION

The XR-1468/1568 is a dual polarity tracking voltage regulator combining two separate regulators with a common reference element in a single monolithic circuit, thus providing a very close balance between the positive and negative output voltages. Outputs are internally set to ± 15 Volts but can be externally adjusted between ± 8.0 to ± 20 Volts with a single control. The circuit features ± 100 mA output current, with externally adjustable current limiting, and provision for remote voltage sensing.

XR-1468/1568

ELECTRICAL CHARACTERISTICS

Test conditions: ($V_{CC} = +20V$, $V_{EE} = -20V$, $C1 = C2 = 1500 \text{ pF}$, $C3 = C4 = 1.0 \text{ } \mu\text{F}$, $R_{SC}^+ = R_{SC}^- = 4.0\Omega$. $I_L^+ = I_L^- = 0$, $T_C = +25^\circ\text{C}$ unless otherwise noted.)

PARAMETERS	XR-1468C			XR-1568			UNITS
	MIN	TYP	MAX	MIN	TYP	MAX	
Output Voltage	14.5	15	15.5	14.8	15	15.2	Vdc
Input Voltage	—	—	30	—	—	30	Vdc
Input-Output Voltage Differential	2.0	—	—	2.0	—	—	Vdc
Output Voltage Balance	—	± 50	± 300	—	± 50	± 150	mV
Line Regulation Voltage ($V_{in} = 18V$ to $30V$) (T_L^\dagger to T_H^\ddagger) ^{††}	—	—	10	—	—	10	mV
Load Regulation Voltage ($I_L = 0$ to 50 mA , $T_J = \text{constant}$) ($T_A = T_L$ to T_H)	—	—	10	—	—	10	mV
Output Voltage Range	8.0	—	20	8.0	—	20	Vdc
Ripple Rejection ($f = 120 \text{ Hz}$)	—	75	—	—	75	—	dB
Output Voltage Temperature Stability (T_L to T_H)	—	0.3	1.0	—	0.3	1.0	%
Short-Circuit Limit ($R_{SC} = 10 \text{ ohms}$)	—	60	—	—	60	—	mA
Output Noise Voltage ($BW = 10 \text{ Hz} - 10 \text{ kHz}$)	—	100	—	—	100	—	$\mu\text{V}(\text{rms})$
Positive Standby Current ($V_{in} = +30V$)	—	2.4	4.0	—	2.4	4.0	mA
Negative Standby Current ($V_{in} = -30V$)	—	1.0	3.0	—	1.0	3.0	mA
Long-Term Stability	—	0.2	—	—	0.2	—	%/kHr

$^\dagger T_L = 0^\circ\text{C}$ for XR-1468C/1568
 $= -55^\circ\text{C}$ for XR-1568M

$^\ddagger T_H = +70^\circ\text{C}$ for XR-1468C/1568
 $= +125^\circ\text{C}$ for XR-1568M

$T_J = \text{Junction Temp.}$
 $T_C = \text{Case Temp.}$

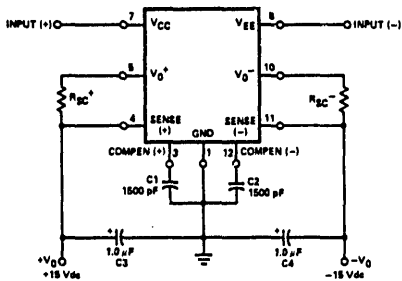

C1 and C2 should be located as close to the device as possible. A $0.1 \text{ } \mu\text{F}$ ceramic capacitor may be required on the input lines if the device is located an appreciable distance from the rectifier filter capacitors.

C3 and C4 may be increased to improve load transient response and to reduce the output noise voltage. At low temperature operation, it may be necessary to bypass C4 with a $0.1 \text{ } \mu\text{F}$ ceramic disc capacitor.

Figure 1. Basic 50 mA Regulator

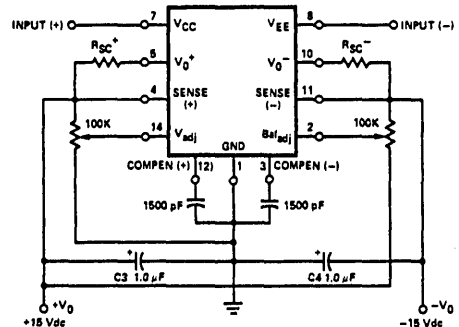

Figure 2. Voltage Adjust and Balance Adjust Circuit