

Timing Circuit

GENERAL DESCRIPTION

The XR-555 monolithic timing circuit is a highly stable controller capable of producing accurate timing pulses. It is a direct, pin-for-pin replacement for the SE/NE 555 timer. The circuit contains independent control terminals for triggering or resetting if desired.

In the monostable mode of operation, the time delay is controlled by one external resistor and one capacitor. For astable operation as an oscillator, the free-running frequency and the duty cycle are accurately controlled with two external resistors and one capacitor (as shown in Figure 2).

The XR-555 may be triggered or reset on falling waveforms. Its output can source or sink up to 200 mA or drive TTL circuits.

FEATURES

- Direct Replacement for SE/NE 555
- Timing from Microseconds Thru Hours
- Operates in Both Monostable and Astable Modes
- High Current Drive Capability (200 mA)
- TTL and DTL Compatible Outputs
- Adjustable Duty Cycle
- Temperature Stability of 0.005%/°C

APPLICATIONS

- Precision Timing
- Pulse Generation
- Sequential Timing
- Pulse Shaping
- Clock Generation
- Missing Pulse Detection
- Pulse-Width Modulation
- Frequency Division
- Pulse-Position Modulation
- Appliance Timing

ABSOLUTE MAXIMUM RATINGS

Power Supply	18 volts
Power Dissipation (package limitation)	
Ceramic Package	385 mW
Plastic Package	300 mW
Derate above +25°C	2.5 mW/°C
Storage Temperature	-65°C to +125°C

FUNCTIONAL BLOCK DIAGRAM

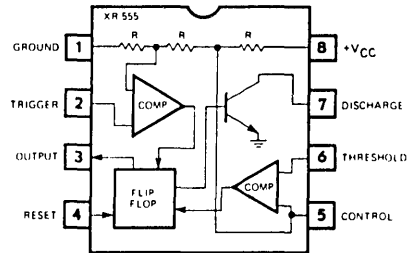

ORDERING INFORMATION

Part Number	Package	Operating Temperature
XR-555M	Ceramic	-55°C to +125°C
XR-555CN	Ceramic	0°C to +70°C
XR-555CP	Plastic	0°C to +70°C

SYSTEM DESCRIPTION

The XR-555 is an industry standard timing circuit capable of both monostable and astable operation with timing intervals ranging from low microseconds up through several hours. Timing is independent of supply voltage, which may range from 4.5 V to 18 V. The output stage can source or sink 200 mA.

In the monostable (one shot) mode, timing is determined by one resistor and capacitor. Astable operations (oscillation) requires an additional resistor, which controls duty cycle. An internal resistive divider provides a reference voltage of $2/3 V_{CC}$, which provides a timing interval of $1.1 RC$. As the reference is related to V_{CC} , the interval is independent of supply voltage; however, for maximum accuracy, the user should ensure V_{CC} does not vary during timing.

The output of the XR-555 is high during the timing interval, and pulls low at timeout. It is triggered and reset on falling waveforms. The control voltage input (Pin 5) may serve as a pulse width modulation point.

For applications requiring dual matched 555-type timers, see the XR-556 and XR-2556. For low voltage and/or low power drain applications, consider the XR-L555 and XR-L556 devices.

XR-555

ELECTRICAL CHARACTERISTICS

Test Conditions: ($T_A = 25^\circ\text{C}$, $V_{CC} = +5\text{V}$ to $+15\text{V}$, unless otherwise specified.)

PARAMETERS	XR-555M			XR-555C			UNITS	CONDITIONS
	MIN	TYP	MAX	MIN	TYP	MAX		
Supply Voltage	4.5		18	4.5		16	V	
Supply Current		3 10	5 12		3 10	6 15	mA mA	Low State Output (Note 1) $V_{CC} = 5\text{V}$, $R_L = \infty$ $V_{CC} = 15\text{V}$, $R_L = \infty$
Timing Error (Monostable)								
Initial Accuracy		0.5	2.0		1.0	3.0	%	$R_A, R_B = 1\text{K}\Omega$ to $100\text{K}\Omega$ Note 2, $C = 0.1\mu\text{F}$ $0^\circ\text{C} \leq T_A \leq 75^\circ\text{C}$
Drift with Temperature		30	100		50		ppm/ $^\circ\text{C}$	
Drift with Supply Voltage		0.05	0.2		0.1	0.5	%/V	
Timing Error (Astable)								
Initial Accuracy (Note 2)		1.5			2.25		%	$R_A, R_B = 1\text{K}\Omega$ to $100\text{K}\Omega$ $C = 0.1\mu\text{F}$ $V_{CC} = 15\text{V}$
Drift with Temperature		90			150		ppm/ $^\circ\text{C}$	
Drift with Supply Voltage		0.15			0.3		%/V	
Threshold Voltage	9.4 2.7	10.0 3.33	10.6 4.0	8.8 2.4	10.0 3.33	11.2 4.2	V V	$V_{CC} = 15\text{V}$ $V_{CC} = 5\text{V}$
Trigger Voltage	1.45 4.8	1.67 5.0	1.9 5.2		1.67 5.0		V V	$V_{CC} = 5\text{V}$ $V_{CC} = 15\text{V}$
Trigger Current		0.5	0.9		0.5	2.0	μA	
Reset Voltage	0.4	0.7	1.0	0.4	0.7	1.0	V	Trigger Input High
Reset Current		0.4	1.0		0.4	1.5	mA	
Threshold Current		0.1	0.25		0.1	0.25	μA	(Note 3)
Control Voltage level	2,7 9.4	3.33 10.0	4.0 10.6	2.4 8.8	3.33 10.0	4.2 11.2	V V	$V_{CC} = 5\text{V}$ $V_{CC} = 15\text{V}$
Output Voltage Drop (Low)		0.10 0.05	0.25 0.2		0.3 0.25	0.35	V V	$V_{CC} = 5\text{V}$ $I_{\text{sink}} = 8.0\text{mA}$ $I_{\text{sink}} = 5.0\text{mA}$ $V_{CC} = 15\text{V}$ $I_{\text{sink}} = 10\text{mA}$ $I_{\text{sink}} = 50\text{mA}$ $I_{\text{sink}} = 100\text{mA}$ $I_{\text{sink}} = 200\text{mA}$
Output Voltage Drop (High)	3.0 13	3.3 13.3		2.75 12.75	3.3 13.3		V V	$I_{\text{source}} = 100\text{mA}$ $V_{CC} = 5\text{V}$ $V_{CC} = 15\text{V}$ $I_{\text{source}} = 200\text{mA}$ $V_{CC} = 15\text{V}$
Turn Off Time (Note 4)		0.5	0.2		0.5		μs	V_{RESET} High
Rise Time of Output		100	200		100	300	nsec	
Fall Time of Output		100	200		100	300	nsec	
Discharge Transistor Leakage		20	100		20	100	nA	

Note 1: Supply current when output is high is typically 1.0 mA less.

Note 2: Tested at $V_{CC} = 5\text{V}$ and $V_{CC} = 15\text{V}$.

Note 3: This will determine the maximum value of $R_A + R_B$ for 15V operation. The maximum total $R = 20$ megohms and for 5V operation, the maximum $R_T = 3.4$ megohms.

Note 4: Time measured from a positive-going input pulse from 0 to $0.8 \times V_{CC}$ into the threshold to the drop from high to low of the output. Trigger is tied to threshold.

XR-555

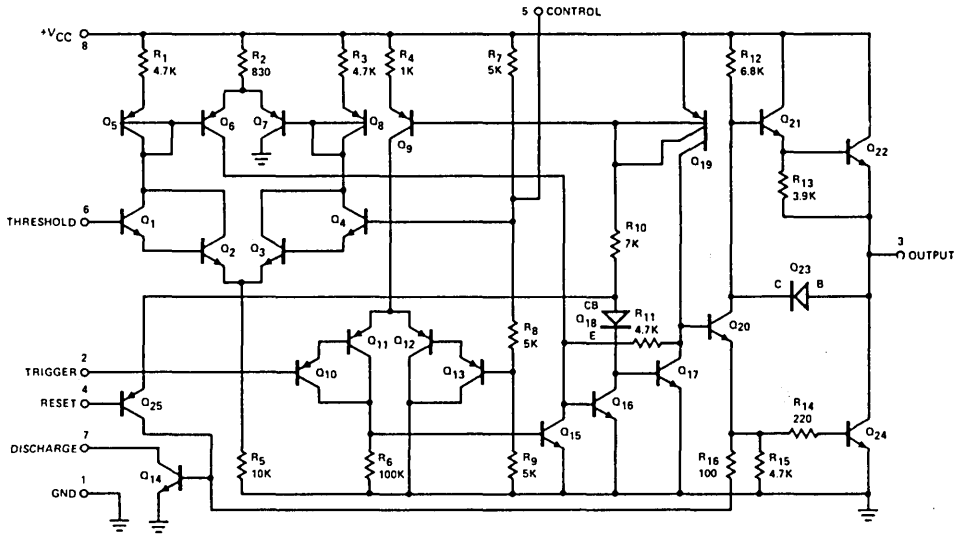

EQUIVALENT SCHEMATIC DIAGRAM

5

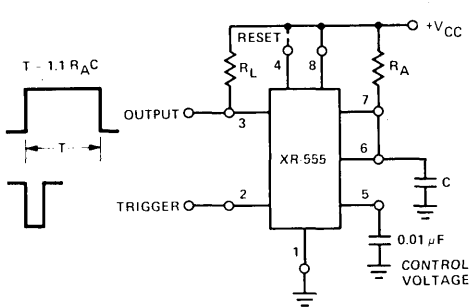

Figure 1. Monostable (One-Shot) Circuit

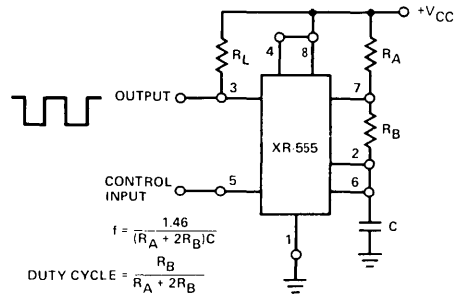

Figure 2. Astable (Free-Running) Circuit