

## Dual Line Driver

### GENERAL DESCRIPTION

The XR-T5675 is a bipolar monolithic dual line driver designed to drive PCM lines up to a 10 MBPS rate. The device is powered from a single  $5V \pm 5\%$  source. Its current consumption is 14mA (typical) and the output can be pulled up to 20VDC.

### FEATURES

- 50mA Output Drive Current Capability
- Low Current Consumption (18mA Max.)
- High Speed Switching
- Dual Matched Driver Outputs
- High Output Voltage
- TTL or DTL Compatible Inputs

### APPLICATIONS

- T1, T1C, T2, 2.048MBPS and 8.448MBPS PCM Line Driver
- LAN Line Driver
- Relay Driver
- LED/Lamp Driver

### ABSOLUTE MAXIMUM RATINGS

Supply Voltage ( $V_{CC}$ )	+7.0V
Input Voltage (Pin 1,2,6,7)	-0.2V to $+V_{CC}$
Output Pull-up Voltages (Pin 3,5)	+35.0V
Power Dissipation	
Ceramic	700mW
Plastic	600mW
Storage Temperature	-65°C to 150°C

### PIN ASSIGNMENT

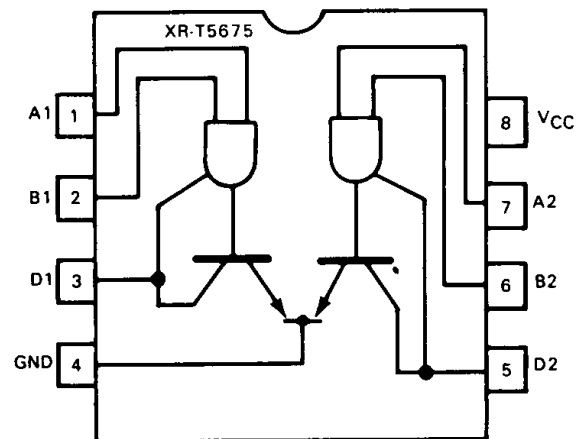

### ORDERING INFORMATION

Part Number	Package	Operating Temperature
XR-T5675CP	Plastic	0°C to +70°C
XR-T5675CN	Ceramic	0°C to +70°C
XR-T5675 D	SOIC	0°C to +70°C

### SYSTEM DESCRIPTION

Figure 1 contains the Functional Block Diagram of the XR-T5675. The circuit consists of two AND logic gates with their outputs internally connected to the bases of the output transistors. The low level outputs are clamped at 1 VBE to ground to insure non-saturating operation for fast switching.

A	B	OUTPUT (D)
L	L	H (OFF)
L	H	H (OFF)
H	L	H (OFF)
H	H	L (ON)

Truth Table — XR-T5675  
H = High Level, L = Low Level

## ELECTRICAL CHARACTERISTICS

Test Conditions:  $V_{CC} = 5.0V$ ,  $T_A = 0^{\circ}C$  to  $+70^{\circ}C$ , unless specified otherwise,

SYMBOL	PARAMETERS	PINS	MIN	TYP	MAX	UNIT	CONDITIONS
$V_{CC}$	Supply Voltage	8	4.75	5.0	5.25	V	
$V_{IH}$	High Level Input Voltage	1,2,6,7	2.2			V	$I_{OL} = 50mA$ , $V_{OL} = 0.95V$
$V_{IL}$	Low Level Input Voltage	1,2,6,7			0.8	V	
$I_{IH}$	High Level Input Current	1,2,6,7			40	$\mu A$	$V_{IH} = 2.7V$ , Pins 3 & 5 Open
$I_{IL}$	Low Level Input Current	1,2,6,7			-1.2	mA	$V_{IL} = 0.4V$ , Pins 3 & 5 Open
$V_{OL}$	Low Level Output Voltage	3,5	0.6		0.95	V	$V_{IH} = 2.2V$ , $I_{OL} = 50mA$
$I_{OL}$	Low Level Output Current	3,5			50	mA	$V_{IH} = 2.2V$ , $V_{OL} = 0.95V$
$I_{OH}$	High Level Leakage Current	3,5			100	$\mu A$	Pins 3 & 5, Pull-up to +20V
$I_{cch}$	Supply Current Output High	8			3.0	mA	Pins 3 & 5 Open
$I_{ccl}$	Supply Current Output Low	8		14.0	18.0	mA	Pins 3 & 5 Open
<b>SWITCHING CHARACTERISTICS, <math>V_{CC} = 5.0V \pm 5\%</math>, <math>T_A = +25^{\circ}C</math></b>							
$t_{pLH}$	Propagation Delay, Low to High	3,5		15		ns	See Figure 2
$t_{pHL}$	Propagation Delay, High to Low	3,5		15		ns	See Figure 2
$t_{rise}$	Rise Time	3,5		15	24	ns	See Figure 2
$t_{fall}$	Fall Time	3,5		10	24	ns	See Figure 2
	Output Pulse Imbalance			2.5		ns	At 50% Output Level

# XR-T5675

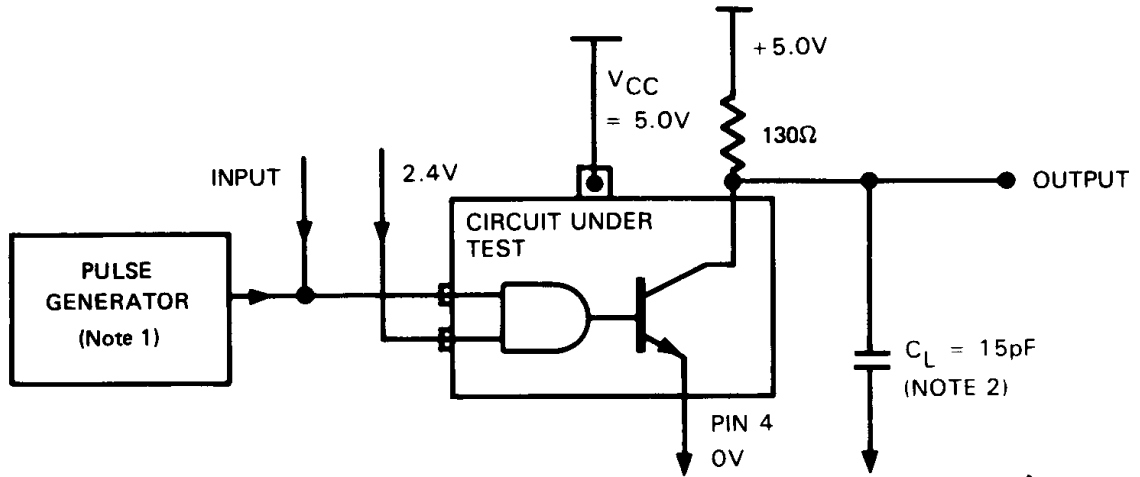

**Note 1.** Pulse Generator Frequency = 2.0MHz,  $Z_{OUT} = 50\Omega$ .  
**Note 2.**  $C_L$  Included — Probe and Jig Capacitance

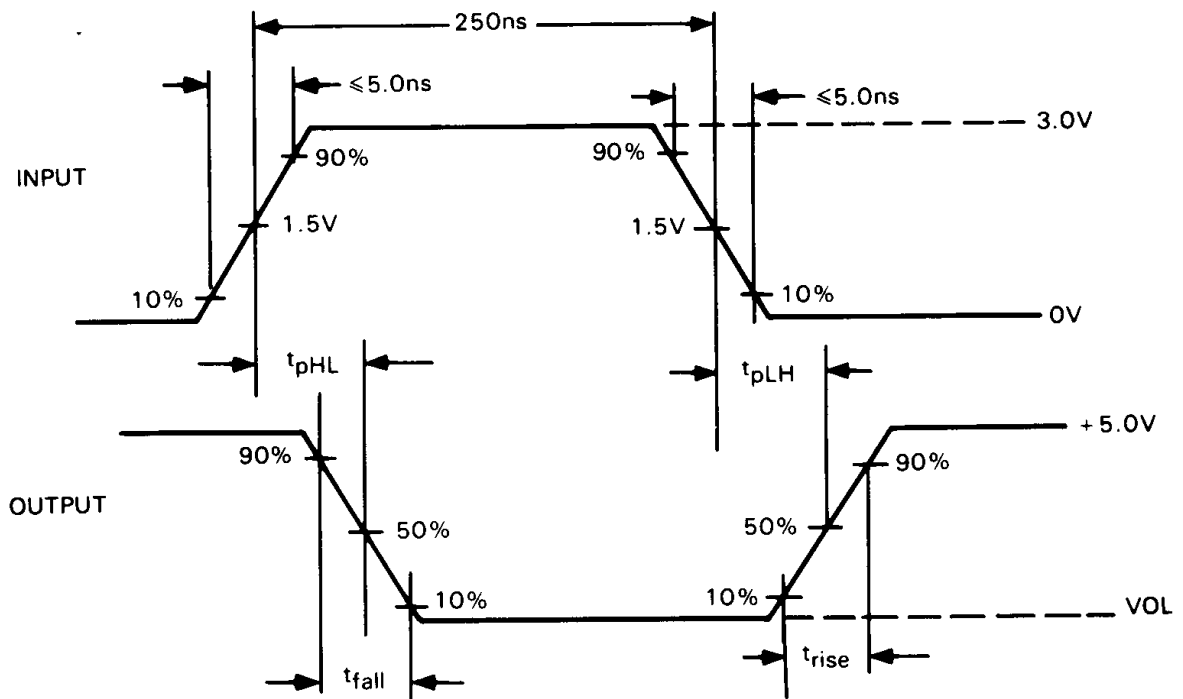

**Figure 2. AC Test Circuit and Switching Waveforms**

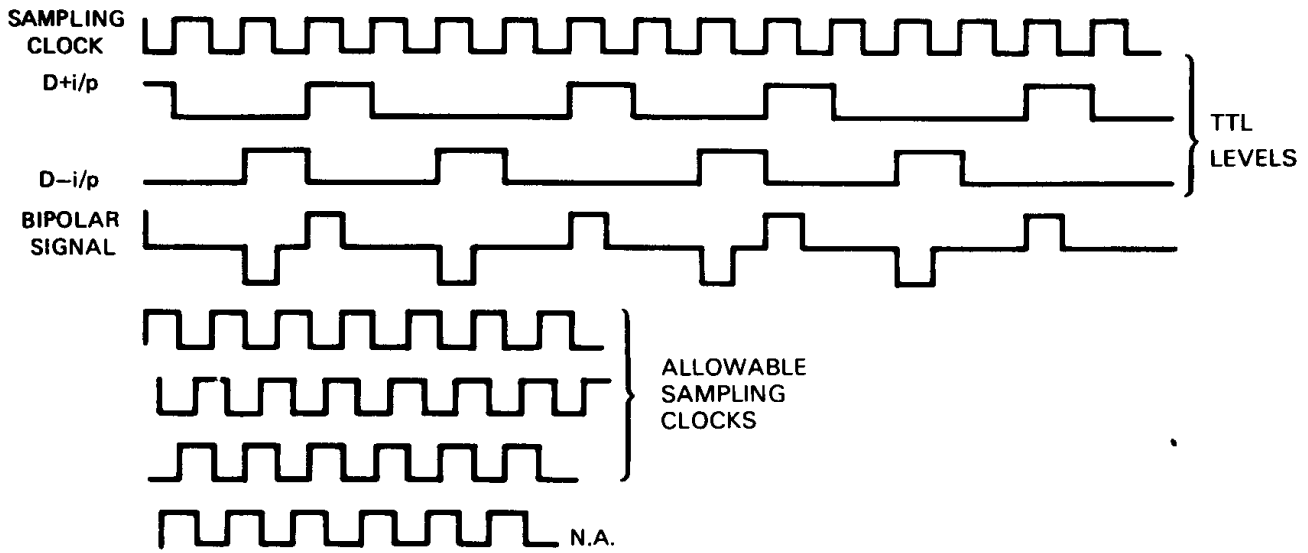

\*  $R_X$  is intended for matching line impedance, but its final value may be determined by the output signal amplitude required.

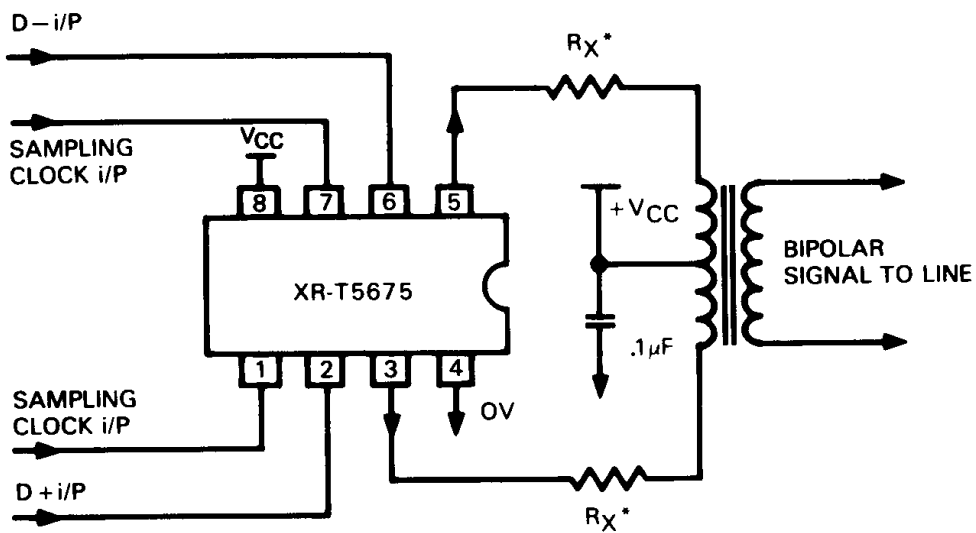

In the case where D+ and D- are half width signals, Pin 1 and Pin 7 should be tied together and returned to +5.0V via a 1K resistor

Figure 3. XR-T5675 PCM Line Driver Application Circuit