

Active Load Current Regulator for Phase-Cut Dimmable AC Direct Drive LED Lamp

Description

The **XR46010** is an active load current regulator for phase-cut dimmable AC direct drive LED lamp system. The active load circuit can provide the holding current for TRIAC and also the charging current path of R/C circuit in a dimmer. It can help to stabilize TRIAC operation and increase the dimming range of the lamp system.

The application of the XR46010 is configured in parallel with an LED string. It conducts the current when the LED string is in off state, and stops conducting the current when the LED string is in on state.

The active load circuit can be placed in the same board with the LED string or a separate board in front of the LED board. The design is very flexible to meet various shape requirements.

FEATURES

- 3V to 80V input operation range
- 250mV low current sense voltage
- Linear over temperature protection

APPLICATIONS

- LED Lighting Applications
 - Downlight
 - High bay
 - Specialty
 - Architectural

Typical Application

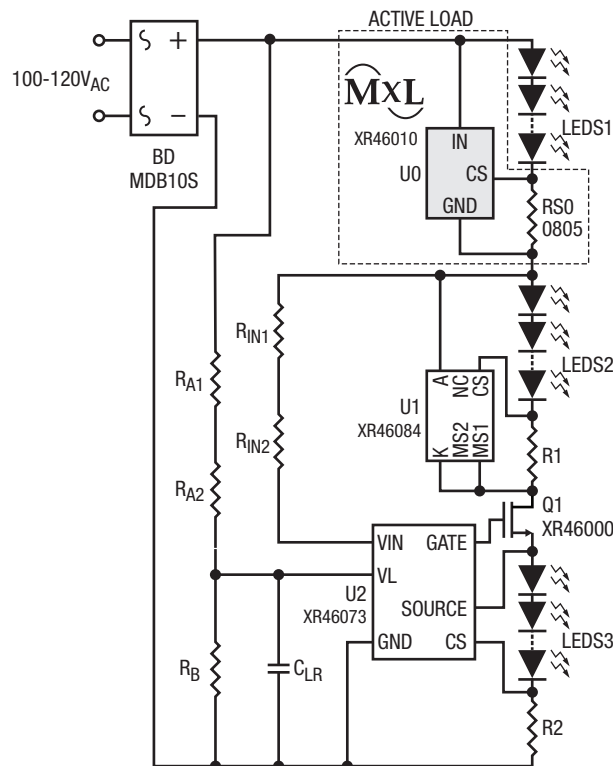

Figure 1. Typical Application

Absolute Maximum Ratings

Stresses beyond the limits listed below may cause permanent damage to the device. Exposure to any Absolute Maximum Rating condition for extended periods may affect device reliability and lifetime.

Sustaining voltage, IN.....	-0.3V to 88V
Sustaining voltage, CS	-0.3V to 5V
Regulating current	75mA
Maximum junction temperature, T _J	165°C
Storage temperature range	-55°C to 150°C
Lead temperature (soldering, 10 seconds).....	260°C
ESD Rating	
HBM - human body model.....	±2kV
MM - machine model.....	±200V

NOTES:

All voltages are with respect to ground. Currents are positive into negative out of the specified terminal.
All parameters having min/max specifications are guaranteed. Typical values are for reference purpose only.
Unless otherwise noted, all tests are pulsed tests at the specified temperature, therefore: T_J = T_C = T_A.

Electrical Characteristics

Unless otherwise noted, typical values are at T_A = 25°C.

Symbol	Parameter	Conditions	Min	Typ	Max	Units
V _{CS}	CS pin reference voltage	V _{IN} = 5V	225	250	275	mV
V _{DROP}	Dropout voltage ⁽¹⁾	IN to GND		3	4	V
ΔV _{LR} /V _{CS}	CS pin reference voltage line regulation ⁽²⁾	V _{IN} = 5V and 40V, R _{CS} = 50Ω		±1	±2	%
T _{TP}	Thermal protection trip temperature ⁽³⁾⁽⁴⁾	When T _J is higher than T _{TP} , the V _{CS} decreases to V _{CS,OTP} linearly	110	125		°C
ΔV _{CS} /ΔT _J	Thermal protection mode V _{CS} decreasing slope ⁽²⁾	T _J > T _{TP}		-1.1		%/°C

NOTES:

- Dropout voltage = V_{IN} at (I_{LED} = 90% × (I_{LED} at V_{IN} = 5V)).
- The CS pin reference voltage line regulation is defined as: $\frac{\Delta V_{LR}}{V_{CS}} = \frac{V_{CS}(V_{IN} = 40V) - V_{CS}(V_{IN} = 5V)}{V_{CS}(V_{IN} = 5V)}$.
- Guarantee by design, not by production test.
- When T_J > T_{TP}, the V_{CS} decreases linearly to around 50% at 170°C.

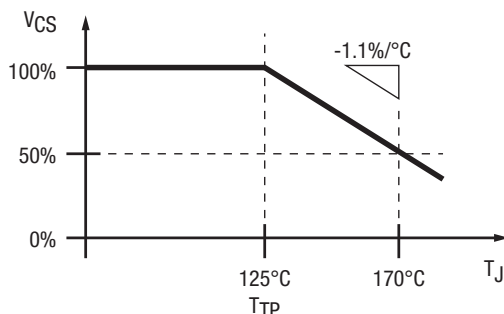
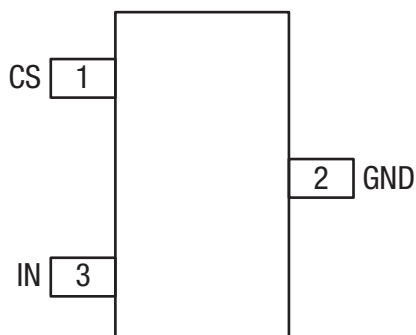

Figure 2. V_{CS} vs. T_J

Pin Configuration



Top View

Pin Functions

Pin Number	Pin Name	Description
1	CS	Current sense and setting pin $I_{LED} = V_{CS}/R_{CS} = 0.25V/R_{CS}$
2	GND	Chip ground pin
3	IN	Power source input pin

Functional Block Diagram

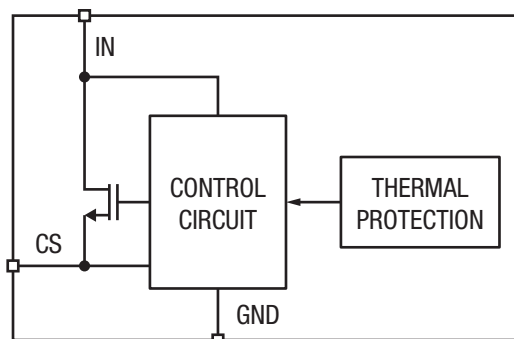

Figure 3. Functional Block Diagram

Applications Information

The addition of XR46010 active load circuit to the XR46084 or the XR46073 system can provide better dimming performance to make it compatible with more types of TRIAC dimmers (phase-cut dimmers), as shown below:

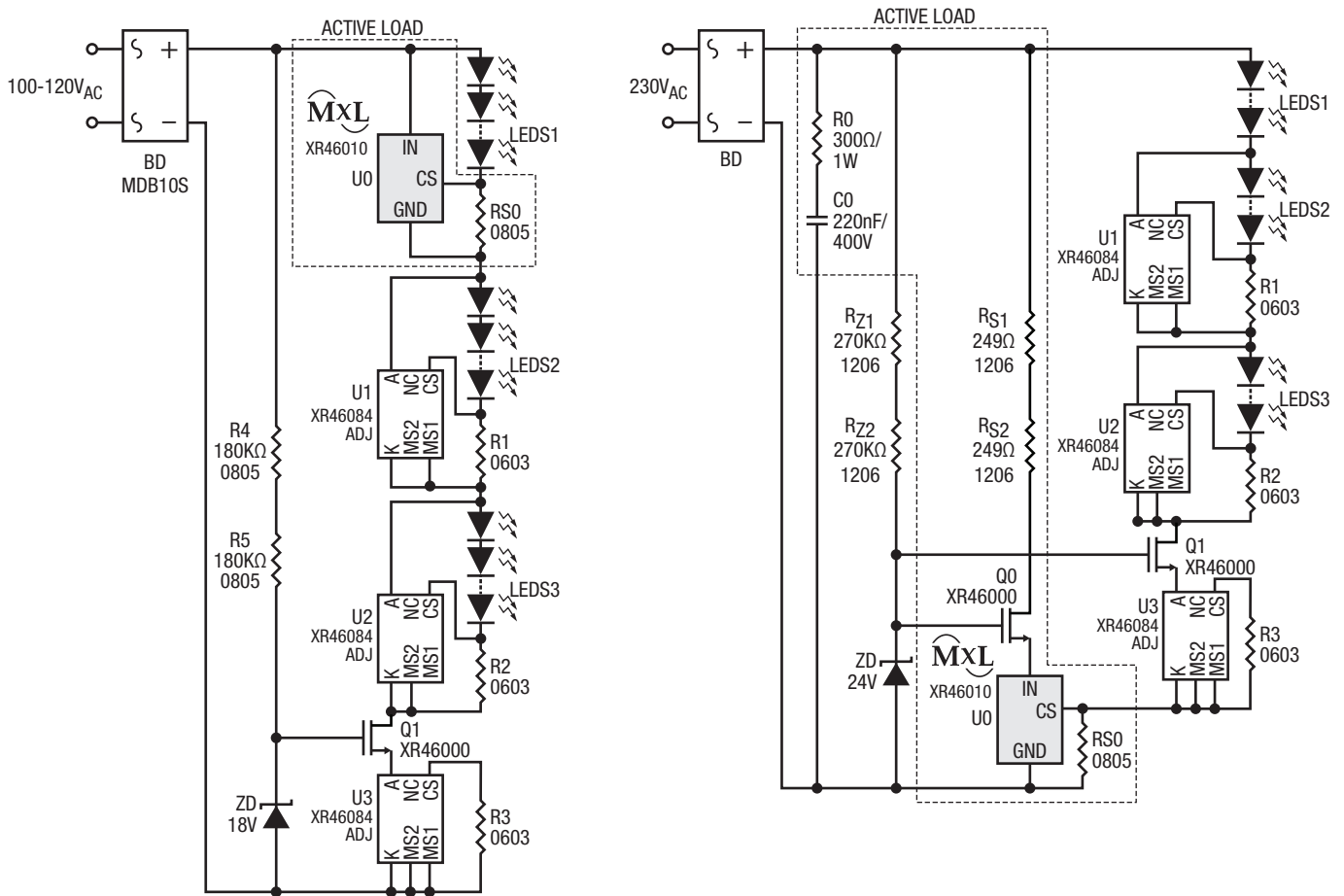

Figure 4. XR46084 3-Step Lamp System

Applications Information (Continued)

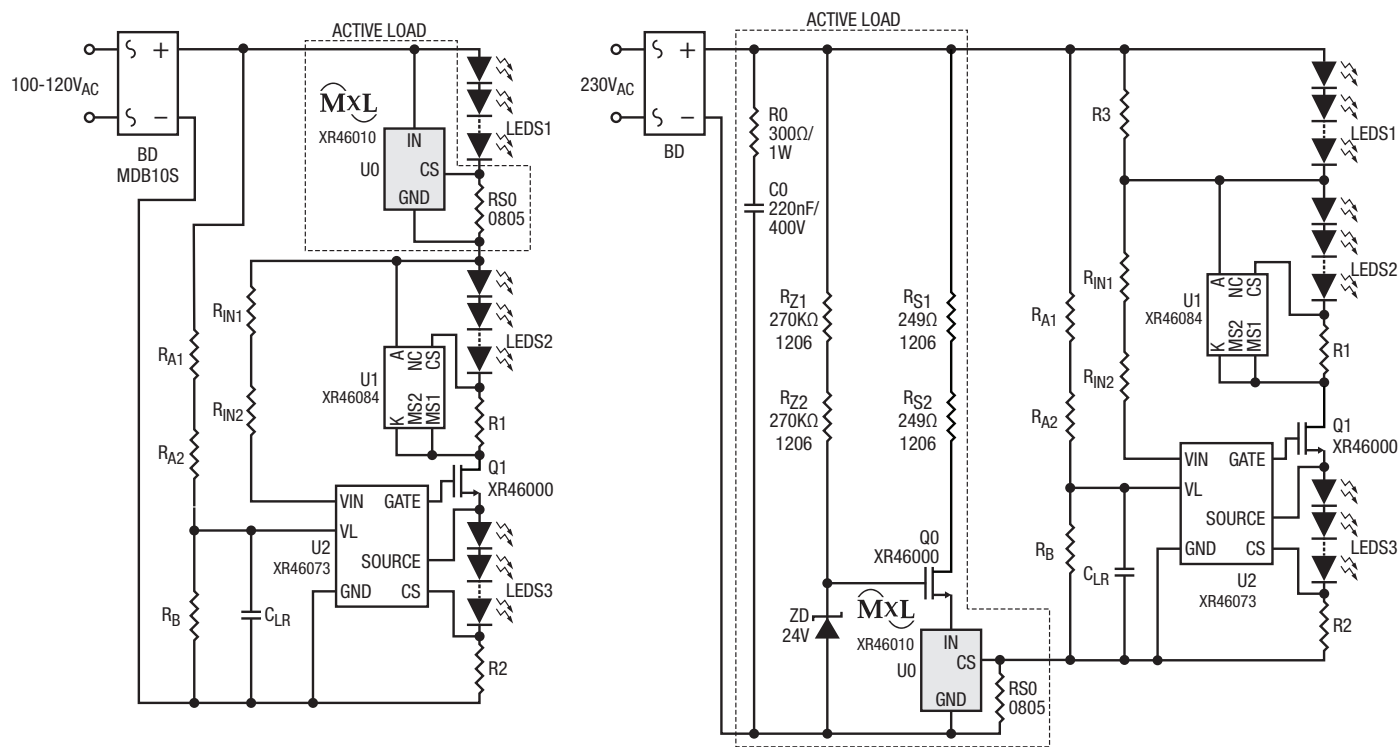
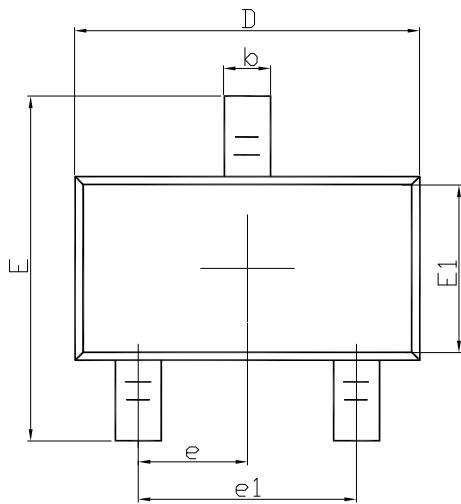
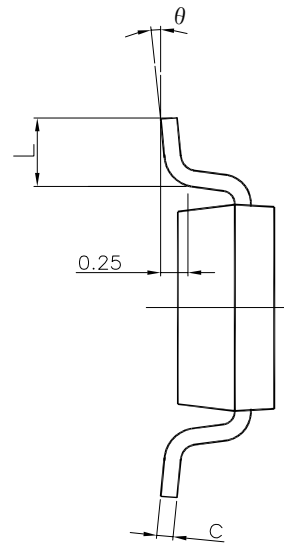

Figure 5. XR46073 3-Step Lamp System

Mechanical Dimensions



TOP VIEW



SIDE VIEW - 1

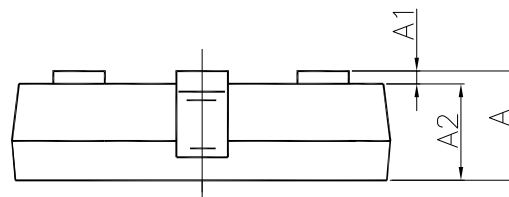

SIDE VIEW - 2

DIM SYMBOL	MIN	NOM	MAX
A	-	NA	0.90
A1	0.000	0.050	0.100
A2	0.700	0.750	0.800
b	0.350	0.425	0.500
c	0.080	1.140	0.200
D	2.820	2.920	3.020
E	2.650	2.800	2.950
E1	1.600	1.650	1.700
e	0.950(BSC)		
e1	1.900(BSC)		
L	0.300	0.450	0.600
θ	0	4	8

TERMINAL DETAILS

- ALL DIMENSIONS ARE IN MILLIMETERS, ANGLES ARE IN DEGREES.
- DIMENSIONS AND TOLERANCE PER JEDEC MO-193.

Drawing No.: POD-00000073

Revision: B

Recommended Land Pattern and Stencil

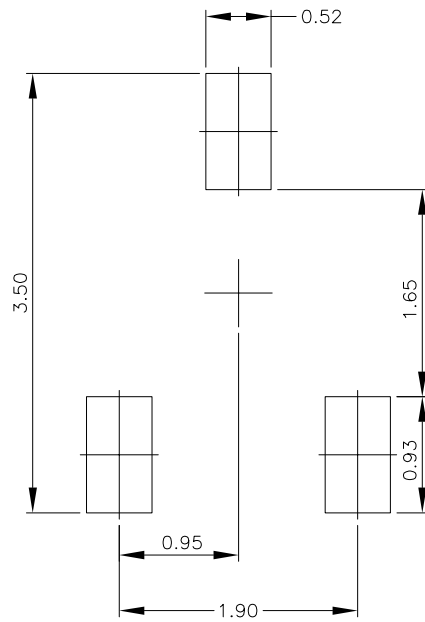

TYPICAL RECOMMENDED LAND PATTERN

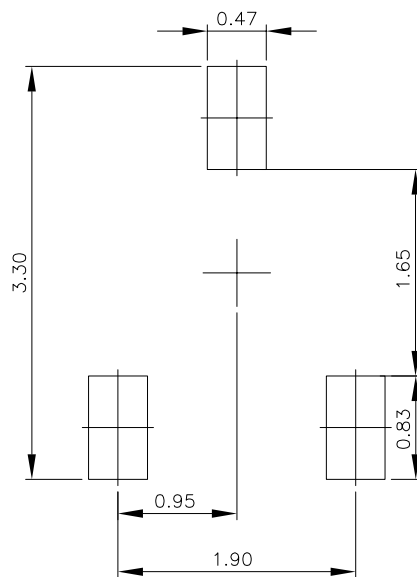

TYPICAL RECOMMENDED STENCIL

Drawing No.: POD-00000073

Revision: B

Ordering Information

Part Number	Junction Temperature Range	Lead-Free	Package	Packaging Method
XR46010ISBTR	$-40^{\circ}\text{C} \leq T_J \leq 150^{\circ}\text{C}$	Yes ⁽²⁾	TSOT-23-3L	Reel

NOTE:

1. Refer to www.exar.com/XR46010 for most up-to-date Ordering Information.
2. Visit www.exar.com for additional information on Environmental Rating.

Revision History

Revision	Date	Description
1.0	June 2015	Initial Release
1.1	October 2015	Change Typical Application Circuit
1A	July 2016	Change to new datasheet format and correct typo in Package Description table
1B	March 2017	Corrected typographical errors; clarified temperature range.
1C	May 2018	Updated to MaxLinear logo. Update format.



Corporate Headquarters:
 5966 La Place Court
 Suite 100
 Carlsbad, CA 92008
 Tel.: +1 (760) 692-0711
 Fax: +1 (760) 444-8598
www.maxlinear.com

High Performance Analog:
 1060 Rincon Circle
 San Jose, CA 95131
 Tel.: +1 (669) 265-6100
 Fax: +1 (669) 265-6101
www.exar.com

The content of this document is furnished for informational use only, is subject to change without notice, and should not be construed as a commitment by MaxLinear, Inc.. MaxLinear, Inc. assumes no responsibility or liability for any errors or inaccuracies that may appear in the informational content contained in this guide. Complying with all applicable copyright laws is the responsibility of the user. Without limiting the rights under copyright, no part of this document may be reproduced into, stored in, or introduced into a retrieval system, or transmitted in any form or by any means (electronic, mechanical, photocopying, recording, or otherwise), or for any purpose, without the express written permission of MaxLinear, Inc.

MaxLinear, Inc. does not recommend the use of any of its products in life support applications where the failure or malfunction of the product can reasonably be expected to cause failure of the life support system or to significantly affect its safety or effectiveness. Products are not authorized for use in such applications unless MaxLinear, Inc. receives, in writing, assurances to its satisfaction that: (a) the risk of injury or damage has been minimized; (b) the user assumes all such risks; (c) potential liability of MaxLinear, Inc. is adequately protected under the circumstances.

MaxLinear, Inc. may have patents, patent applications, trademarks, copyrights, or other intellectual property rights covering subject matter in this document. Except as expressly provided in any written license agreement from MaxLinear, Inc., the furnishing of this document does not give you any license to these patents, trademarks, copyrights, or other intellectual property.

Company and product names may be registered trademarks or trademarks of the respective owners with which they are associated.