



XR75100

40V Synchronous Step Down COT Controller

General Description

The XR75100 is a synchronous step-down controller for point-of load supplies up to 20A. A wide 5.5V to 40V input voltage range allows for single supply operation from industry standard 12V, 18V, and 24V DC and AC rails.

With a proprietary emulated current mode Constant On-Time (COT) control scheme, the XR75100 provides extremely fast line and load transient response using ceramic output capacitors. It requires no loop compensation hence simplifying circuit implementation and reducing overall component count. The control loop also provides exceptional load and line regulation and maintains constant operating frequency. A selectable power saving mode allows the user to operate in discontinuous mode (DCM) at light current loads thereby significantly increasing the converter efficiency.

A host of protection features, including over-current, over-temperature, short-circuit and UVLO, help achieve safe operation under abnormal operating conditions.

The XR75100 is available in RoHS compliant, green/halogen free space-saving 16-pin 3x3 QFN package.

FEATURES

- 20A Capable Step Down Controller
 - Wide 5.5V to 40V Input Voltage Range
 - Integrated High Current 2A/3A Drivers
 - 0.6 to 30V Adjustable Output Voltage
- Proprietary Constant On-Time Control
 - No Loop Compensation Required
 - Stable Ceramic Output Capacitor Operation
 - Programmable 200ns to 2µs On-Time
 - Constant 100kHz to 800kHz Frequency
 - Selectable CCM or CCM/DCM Operation
- Programmable Hiccup Current Limit with Thermal Compensation
- Precision Enable and Power Good flag
- Programmable Soft-start
- Integrated Bootstrap diode
- 16-pin QFN package

APPLICATIONS

- Networking and Communications
- Fast Transient Point-of-Loads
- Industrial and Medical Equipment
- Embedded High Power FPGA

Ordering Information – [back page](#)

Typical Application

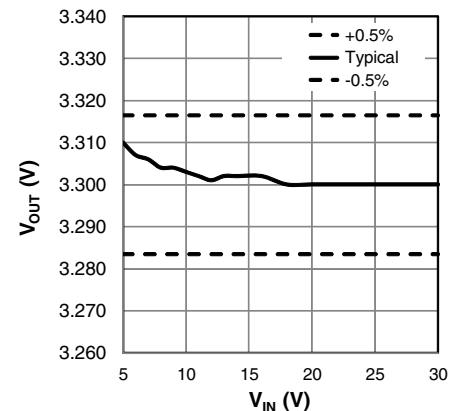
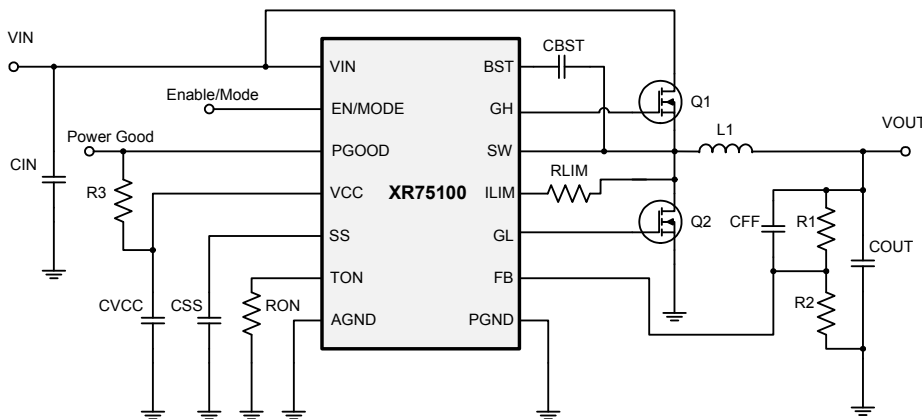

Absolute Maximum Ratings

Stresses beyond the limits listed below may cause permanent damage to the device. Exposure to any Absolute Maximum Rating condition for extended periods may affect device reliability and lifetime.

V_{IN}	-0.3V to 43V
V_{CC}	-0.3V to 6.0V
BST.....	-0.3V to 48V ²
BST-SW.....	-0.3V to 6V
SW, ILIM.....	-5V to 43V ^{1, 2}
GH.....	-0.3V to BST+0.3V
GH-SW.....	-0.3V to 6V
ALL other pins.....	-0.3V to VCC+0.3V
Storage Temperature.....	-65°C to +150°C
Junction Temperature.....	150°C
Power Dissipation.....	Internally Limited
Lead Temperature (Soldering, 10 sec).....	300°C
ESD Rating (HBM - Human Body Model).....	2kV

Operating Conditions

V_{IN}	-0.3V to 40V
V_{CC}	-0.3V to 5.5V
SW, ILIM.....	-1V to 40V ¹
PGOOD, TON, SS, EN, GL, FB.....	-0.3V to 5.5V
Switching Frequency.....	100kHz to 800kHz ³
Junction Temperature Range.....	-40°C to +125°C

Note 1: SW pin's minimum DC range is -1V, transient is -5V for less than 50ns.

Note 2: No external voltage applied.

Note 3: Recommended

Electrical Characteristics

Unless otherwise noted: $T_J = 25^\circ\text{C}$, $V_{IN} = 24\text{V}$, $BST = V_{CC}$, $SW = AGND = PGND = 0\text{V}$, $CGH = CGL = 3.3\text{nF}$, $4.7\mu\text{F}$ at $V_{CC} - AGND$. Limits applying over the full operating temperature range are denoted by a “•”

Symbol	Parameter	Conditions		Min	Typ	Max	Units
Power Supply Characteristics							
V_{IN}	Input Voltage Range	VCC regulating	•	5.5		40	V
I_{VIN}	VIN Input Supply Current	Not switching, $V_{IN} = 24\text{V}$, $V_{FB} = 0.7\text{V}$	•		0.7	2	mA
		$f = 300\text{kHz}$, $R_{ON} = 215\text{k}$, $V_{FB} = 0.58\text{V}$			11		mA
I_{OFF}	Shutdown Current	Enable = 0V, $V_{IN} = 24\text{V}$			0.1		μA
Enable and Under-Voltage Lock-Out UVLO							
V_{IH_EN}	EN Pin Rising Threshold		•	1.8	1.9	2.0	V
V_{EN_HYS}	EN Pin Hysteresis				50		mV
V_{IH_EN}	EN Pin Rising Threshold for DCM/CCM operation		•	2.9	3.0	3.1	V
V_{EN_HYS}	EN Pin Hysteresis				100		mV
	VCC UVLO Start Threshold, Rising Edge		•	4.00	4.25	4.50	V

Symbol	Parameter	Conditions		Min	Typ	Max	Units
	VCC UVLO Hysteresis				200		mV
Reference Voltage							
V _{REF}	Reference Voltage	V _{IN} = 5.5V to 40V		0.597	0.600	0.603	V
			•	0.594	0.600	0.606	V
	DC Line Regulation	CCM, closed loop, V _{IN} =5.5V-30V, applies to any C _{OUT}			±0.3		%
	DC Load Regulation	CCM, closed loop, I _{OUT} =0A-10A, applies to any C _{OUT}			±0.15		%
Programmable Constant On-Time							
	Maximum Recommended On-Time	R _{ON} = 237k, V _{IN} = 40V			2.0		us
	On-Time 1	R _{ON} = 237k, V _{IN} = 40V	•	1.7	2.0	2.3	us
	f Corresponding to On-Time 1	V _{IN} = 40V, V _{OUT} = 24V		261	300	353	kHz
	Minimum Programmable On-Time	R _{ON} = 14k, V _{IN} = 40V			120		ns
		R _{ON} = 14k, V _{IN} = 24V			200	230	ns
	On-Time 2	R _{ON} = 14k, V _{IN} = 24V	•	170	200	230	ns
	f Corresponding to On-Time 2	V _{OUT} = 5V		906	1042	1225	kHz
		V _{OUT} = 3.3V		598	688	809	kHz
	On-Time 3	R _{ON} = 35.7k, V _{IN} = 24V	•	430	506	582	ns
	Minimum Off-Time		•		250	350	ns
Diode Emulation Mode							
	Zero Crossing Threshold	DC value measured during test		-4	-1	2	mV
Soft-start							
	SS Charge Current		•	-14	-10	-6	μA
	SS Discharge Current	Fault present	•	1			mA
VCC Linear Regulator							
	VCC Output Voltage	V _{IN} = 6V to 40V, I _{LOAD} = 0 to 30mA	•	4.8	5.0	5.2	V
		V _{IN} = 5.5V, I _{LOAD} = 0 to 20mA	•	4.8	5.0	5.2	V
Power Good Output							
	Power Good Threshold			-10	-7.5	-5	%
	Power Good Hysteresis				2	4	%
	Power Good Sink Current			1			mA
Protection: OCP, OTP, Short-Circuit							
	Hiccup Timeout				110		ms
	ILIM Pin Source Current			45	50	55	μA
	ILIM Current Temperature Coefficient				0.4		%/°C

Symbol	Parameter	Conditions		Min	Typ	Max	Units
	OCP Comparator Offset		•	-8	0	+8	mV
	Current Limit Blanking	GL rising > 1V			100		ns
	Thermal Shutdown Threshold ¹	Rising temperature			150		°C
	Thermal Hysteresis ¹				15		°C
	VSCTH Feedback Pin Short-Circuit Threshold	Percent of VREF, short circuit is active after PGOOD is up	•	50	60	70	%
Output Gate Drivers							
	GH Pull-Down Resistance	IGH = 200mA			1.35	2.0	Ω
	GH Pull-Up Resistance	IGH = 200mA			1.8	2.8	Ω
	GL Pull-Down Resistance	IGL = 200mA			1.35	1.9	Ω
	GL Pull-Up Resistance	IGL = 200mA			1.7	2.7	Ω
	GH and GL Pull-down Resistance				50		kΩ
	GH and GL Rise Time	10% to 90%			35	50	ns
	GH and GL Fall Time	90% to 10%			30	40	ns
	GL to GH Non-Overlap Time	Measured GL falling edge = 1V to GH rising edge = 1V, BST=VCC, SW = 0V			30	60	ns
	GH to GL Non-Overlap Time	Measured GH falling edge = 1V to GL rising edge = 1V			20	40	ns

Note 1: Guaranteed by design

Pin Configuration

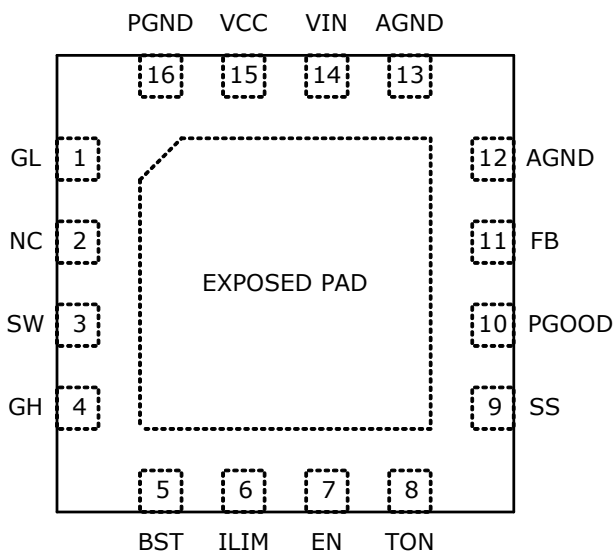

Pin Assignments

Pin No.	Pin Name	Type	Description
1	GL	O	Driver output for Low-side N-channel synchronous MOSFET.
2	NC		Internally not connected. Leave this pin floating.
3	SW	A	Lower supply rail for high-side gate driver GH. Connect this pin to the junction between the two external N-channel MOSFETs.
4	GH	O	Driver output for high-side N-channel switching MOSFET.
5	BST	A	High-side driver supply pin. Connect a 0.1uF bootstrap capacitor between BST and SW.
6	ILIM	A	Over-current protection programming. Connect with a resistor to the drain of the low-side MOSFET.
7	EN/MODE	I	Precision enable pin. Pulling this pin above 1.9V will turn the IC on and it will operate in Forced CCM. If the voltage is raised above 3.0V, then the IC will operate in DCM or CCM depending on load.
8	TON	A	Constant on-time programming pin. Connect with a resistor to AGND.
9	SS	A	Soft-start pin. Connect an external capacitor between SS and AGND to program the soft-start rate based on the 10uA internal source current.
10	PGOOD	OD	Power-good output. This open-drain output is pulled low when VOUT is outside the regulation.
11	FB	A	Feedback input to feedback comparator. Connect with a set of resistors to VOUT and GND in order to program VOUT.
12, 13	AGND	A	Analog ground. Control circuitry of the IC is referenced to this pin.
14	VIN	PWR	IC supply input. Provides power to internal LDO.
15	VCC	PWR	The output of LDO. For operation using a 5V rail, VCC should be shorted to VIN.
16	PGND	PWR	Low side driver ground
	Exposed Pad	A	Thermal pad for heat dissipation. Connect to AGND with a short trace.

Type: A = Analog, I = Input, O = Output, I/O = Input/Output, PWR = Power, OD = Open-Drain

Functional Block Diagram

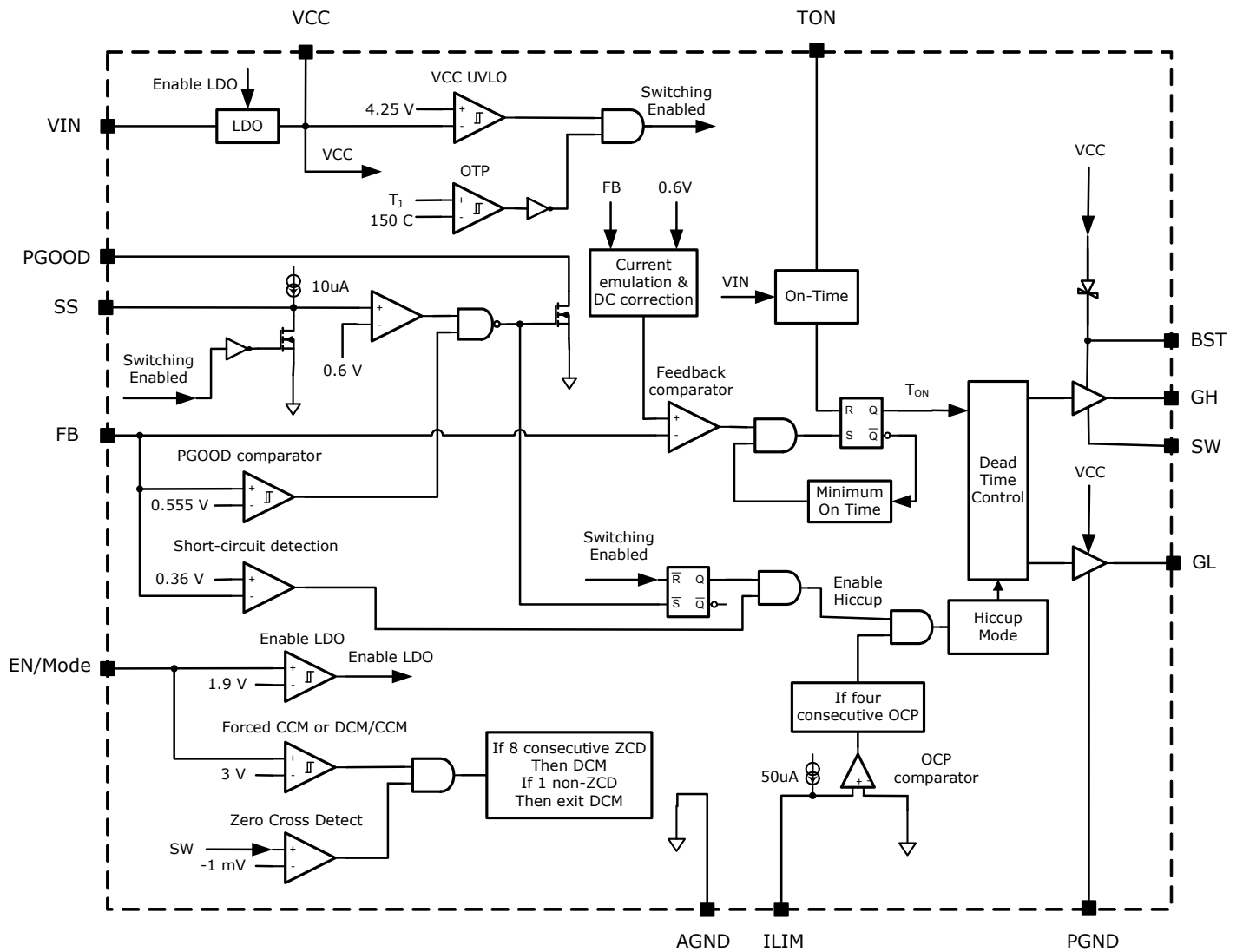

Typical Performance Characteristics

Unless otherwise noted: $V_{IN} = 24V$, $V_{OUT}=3.3V$, $I_{OUT}=10A$, $f=500kHz$, $T_A = 25^{\circ}C$. Schematic from the application information section.

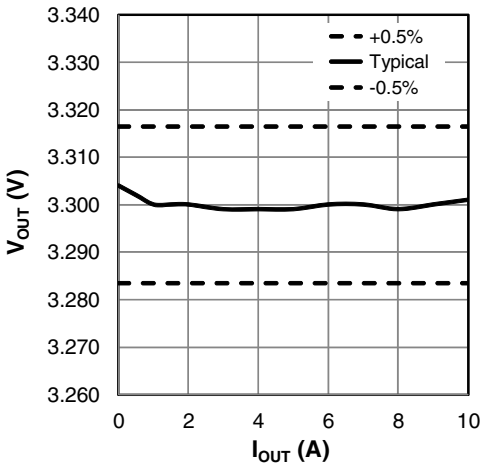

Figure 1: Load Regulation

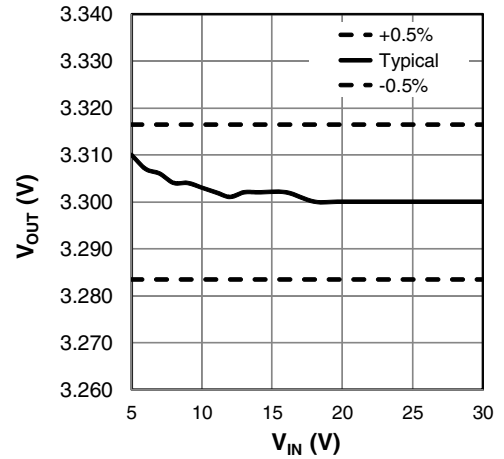

Figure 2: Line regulation

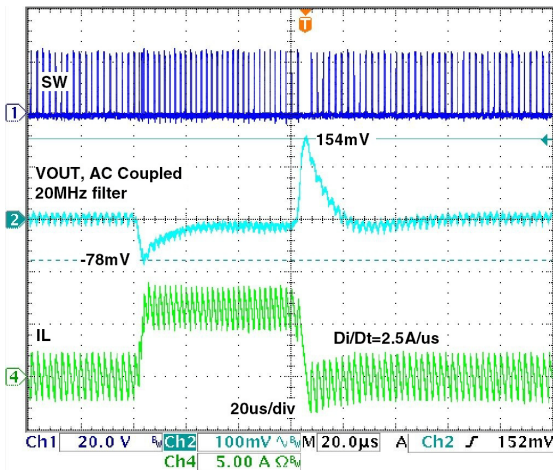

Figure 3: Load step, Forced CCM, 0A-6.5A-0A

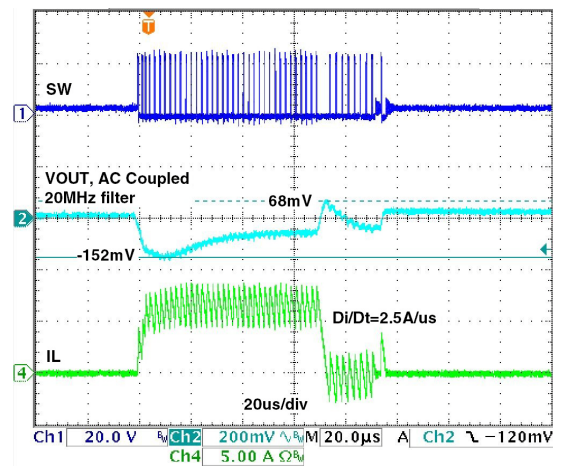

Figure 4: Load step, DCM/CCM, 0A-6.5A-0A

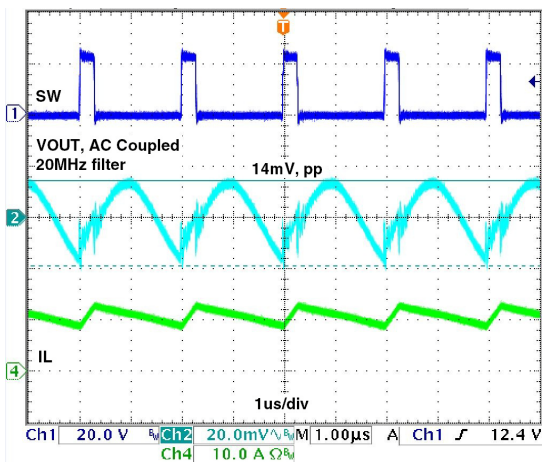

Figure 5: Steady state, $V_{OUT,ripple}=14mV$, $I_{OUT}=10A$

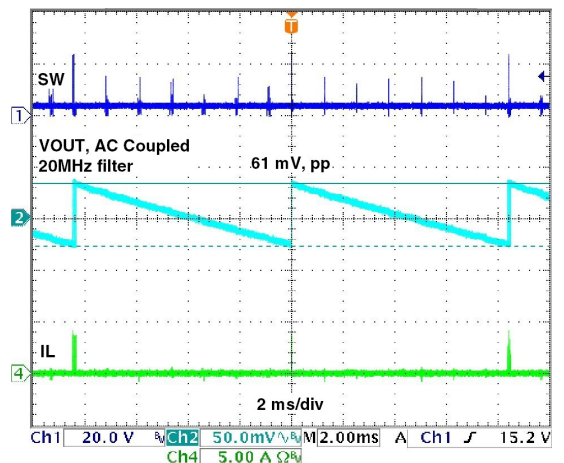

Figure 6: Steady state, DCM, $V_{OUT,ripple}=61mV$, $I_{OUT}=0A$

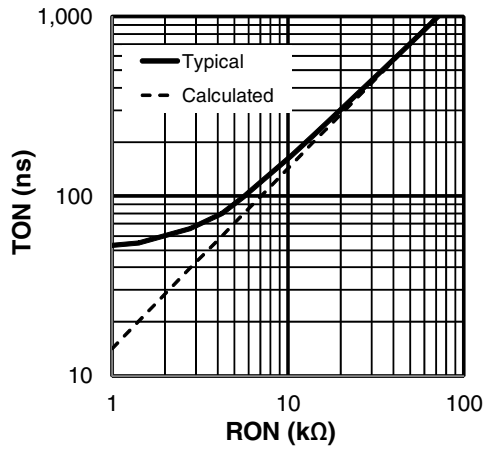

Figure 7: TON versus RON, $V_{IN}=24V$

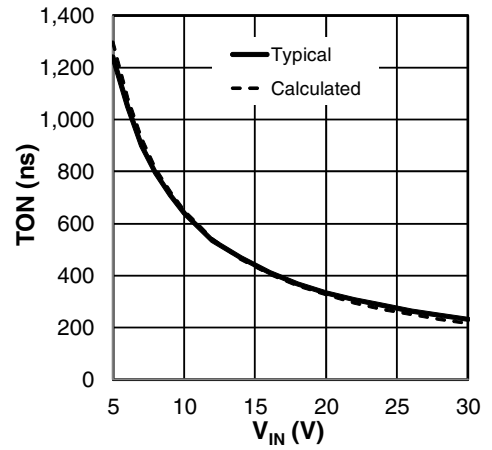

Figure 8: TON versus V_{IN} , $R_{ON}=19.1k$

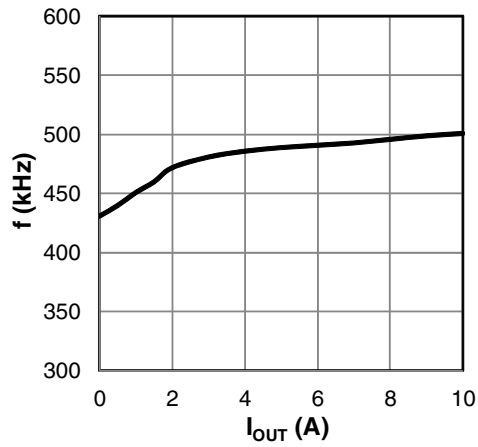

Figure 9: frequency versus I_{OUT} , $V_{IN}=24V$

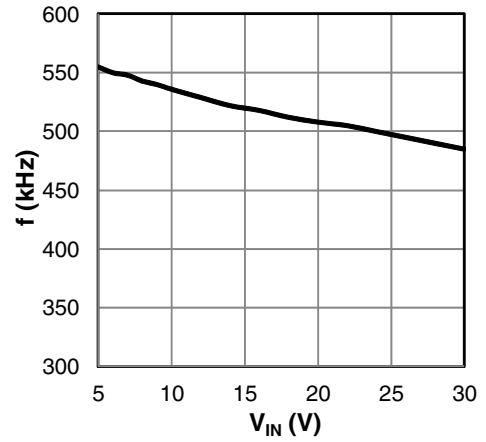

Figure 10: frequency versus V_{IN} , $I_{OUT}=10A$

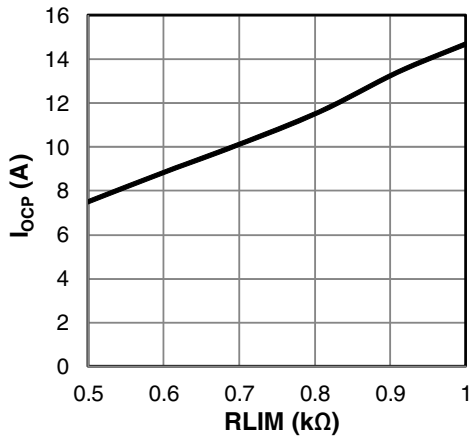

Figure 11: I_{ocp} versus RLIM

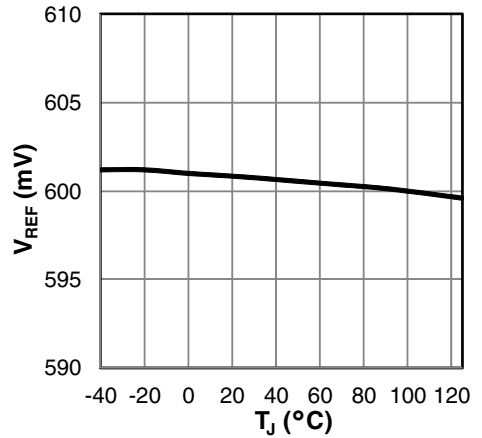

Figure 12: V_{REF} versus temperature

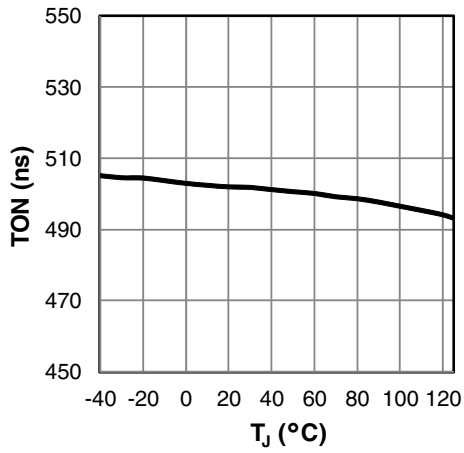

Figure 13: TON versus temperature

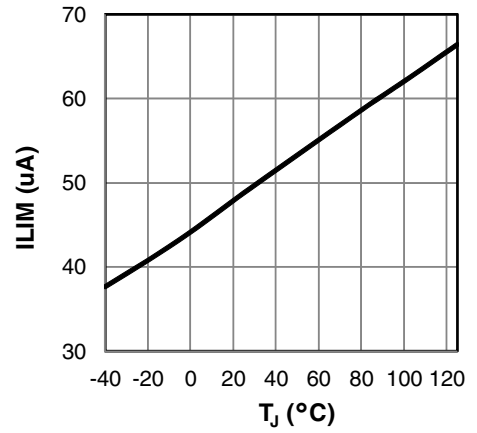

Figure 14: ILIM versus temperature

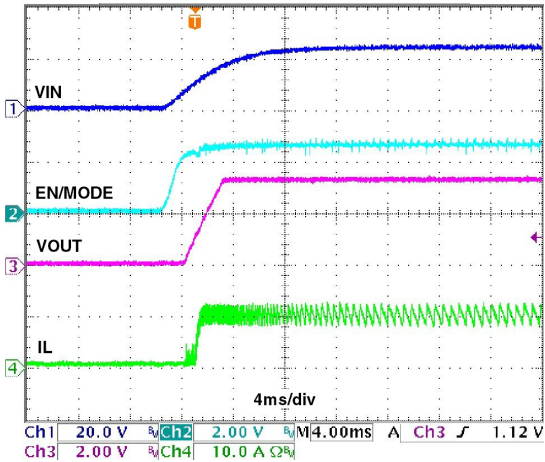

Figure 15: Powerup, Forced CCM

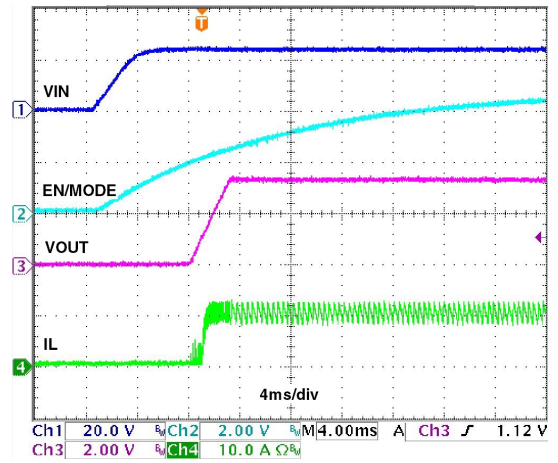

Figure 16: Powerup, DCM/CCM

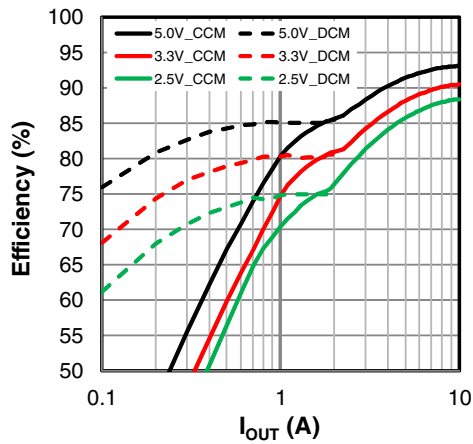

Figure 17: Efficiency, V_{IN}=24V, f=500kHz

Functional Description

XR75100 is a synchronous step-down proprietary emulated current-mode Constant On-Time (COT) controller. The on-time, which is programmed via R_{ON} , is inversely proportional to V_{IN} and maintains a nearly constant frequency. The emulated current-mode control is stable with ceramic output capacitors.

Each switching cycle begins with GH signal turning on the high-side (control) FET for a preprogrammed time. At the end of the on-time, the high-side FET is turned off and the low-side (synchronous) FET is turned on for a preset minimum time (250ns nominal). This parameter is termed Minimum Off-Time. After the minimum off-time, the voltage at the feedback pin FB is compared to an internal voltage ramp at the feedback comparator. When V_{FB} drops below the ramp voltage, the high-side FET is turned on and the cycle repeats. This voltage ramp constitutes an emulated current ramp and makes possible the use of ceramic capacitors, in addition to other capacitor types, for output filtering.

Enable/Mode Input (EN/MODE)

EN/MODE pin accepts a tri-level signal that is used to control turn on/off. It also selects between two modes of operation: 'Forced CCM' and 'DCM/CCM'. If EN is pulled below 1.8V, the controller shuts down. A voltage between 2.0V and 2.9V selects the Forced CCM mode which will run the converter in continuous conduction at all times. A voltage higher than 3.1V selects the DCM/CCM mode which will run the converter in discontinuous conduction at light loads.

Selecting the Forced CCM Mode

In order to set the controller to operate in Forced CCM, a voltage between 2.0V and 2.9V must be applied to EN/MODE. This can be achieved with an external control signal that meets the above voltage requirement. Where an external control is not available, the EN/MODE can be derived from V_{IN} . If V_{IN} is well regulated, use a resistor divider and set the voltage to 2.5V. If V_{IN} varies over a wide range, the circuit shown in figure 18 can be used to generate the required voltage. Note that at V_{IN} of 5.5V and 40V the nominal Zener voltage is 4.0V and 5.0V respectively. Therefore for V_{IN} in the range of 5.5V to 40V, the circuit shown in figure 18 will generate V_{EN} required for Forced CCM.

Selecting the DCM/CCM Mode

In order to set the controller operation to DCM/CCM, a voltage between 3.1V and 5.5V must be applied to EN/MODE pin. If an external control signal is available, it can be directly connected to EN/MODE. In applications where an external control is not available, EN/MODE input can be derived from V_{IN} . If V_{IN} is well regulated, use a resistor

divider and set the voltage to 4V. If V_{IN} varies over a wide range, the circuit shown in figure 19 can be used to generate the required voltage.

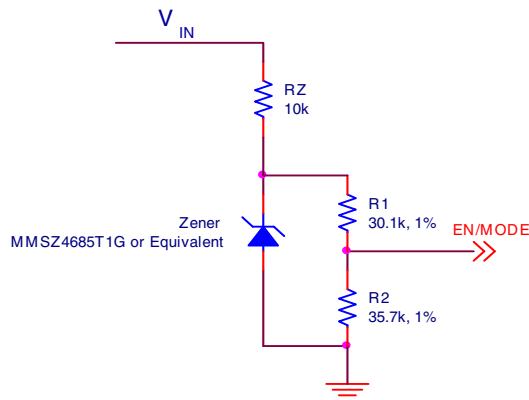

Figure 18: Selecting Forced CCM by deriving EN/MODE from V_{IN}

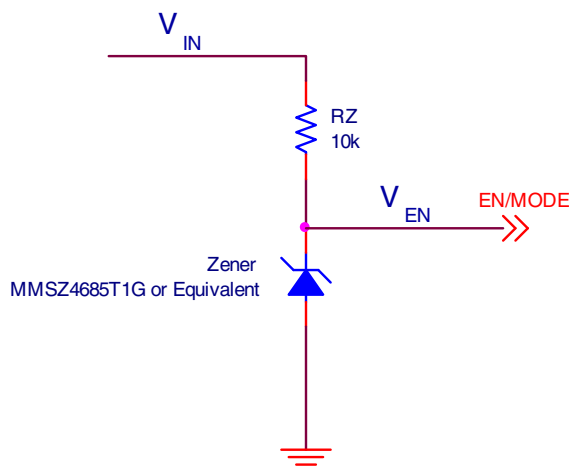

Figure 19: Selecting DCM/CCM by deriving EN/MODE from V_{IN}

DCM Operation

When DCM operation is enabled, the Zero Cross Detect comparator in the XR75100 senses when the current in the inductor reaches 0Amps and turns off the low side MOSFET. The low side MOSFET is operated to emulate the operation of a diode preventing the inductor current from flowing in the negative direction. In this mode the device is now operating in Pulse Frequency Modulation (PFM) control. As the load reduces the frequency reduces and thus the switching losses are reduced resulting in much better efficiency at light load. The Zero Cross comparator monitors the voltage across the low side MOSFET to determine the

correct time to turn it off. Ideally, this threshold is -1mV, meaning there is still positive current in the inductor (positive inductor current refers to current from SW to VOUT). However, there is a range to the sensed voltage from -4mV to +2mV. In the case where a very low RDSON low side MOSFET is used a higher negative inductor current is required to reach the +2mV. For instance, a 2mohm MOSFET would require a negative 1A inductor valley current before the XR75100 recognizes the signal to turn off the low side MOSFET. As a result, the XR75100 will not enter PFM until the load reduces further. It should be noted that the net power saving between ideal zero cross detection and the -4mV to +2mV range of the XR75100 is minor. The operating frequency will have changed little from what one would have in the ideal case.

One important feature added to the DCM detection is a counter which allows 8 switching cycles to trigger in the zero cross comparator before enabling DCM operation. This ensures that during large unloading events, the XR75100 will respond quickly. This operation can be seen during the unloading event in Figure 4 in the Typical Performance Characteristics section above.

Programming the On-Time

The On-Time T_{ON} is programmed via resistor R_{ON} according to following equation:

$$R_{ON} = \frac{V_{IN} \times T_{ON}}{3.4 \times 10^{-10}}$$

where T_{ON} is calculated from:

$$T_{ON} = \frac{V_{OUT}}{V_{IN} \times f}$$

As an example the calculated T_{ON} for the application circuit is 275ns. An R_{ON} of 19.4k is required in order to set T_{ON} to 275ns. A graph of typical T_{ON} versus R_{ON} is shown in figure 7.

Over-Current Protection (OCP)

If load current exceeds the programmed over-current I_{OCP} for four consecutive switching cycles, then IC enters hiccup mode of operation. In hiccup the MOSFET gates are turned off for 110ms (hiccup timeout). Following the hiccup timeout a soft-start is attempted. If OCP persists, hiccup timeout will repeat. The IC will remain in hiccup mode until load current

is reduced below the programmed I_{OCP} . In order to program over-current protection use the following equation:

$$R_{LIM} = \frac{(I_{OCP} \times R_{DS}) + 8mV}{I_{LIM}}$$

Where:

R_{LIM} is resistor value for programming I_{OCP}

I_{OCP} is the over-current threshold to be programmed

R_{DS} is the MOSFET rated on resistance

8mV is the OCP comparator offset

I_{LIM} is the internal current that generates the necessary OCP comparator threshold (use 45 μ A).

Note that I_{LIM} has a positive temperature coefficient of 0.4%/°C. This is meant to roughly match and compensate for positive temperature coefficient of the synchronous FET R_{DS} . In order for this feature to be effective the temperature rise of the IC should approximately match the temperature rise of the FET. A graph of typical I_{OCP} versus R_{LIM} is shown in figure 11.

Short-Circuit Protection (SCP)

If the output voltage drops below 60% of its programmed value, the IC will enter hiccup mode. Hiccup will persist until short-circuit is removed. SCP circuit becomes active after PGOOD asserts high.

Over-Temperature (OTP)

OTP triggers at a nominal die temperature of 150°C. The gate of switching FET and synchronous FET are turned off. When die temperature cools down to 135°C, soft-start is initiated and operation resumes.

Programming the Output Voltage

Use an external voltage divider as shown in the application circuit to program the output voltage V_{OUT} .

$$R1 = R2 \times \left(\frac{V_{OUT}}{0.6} - 1 \right)$$

where $R2$ has a nominal value of 2k Ω .

Programming the Soft-start

Place a capacitor C_{SS} between the SS and GND pins to program the soft-start. In order to program a soft-start time of TSS, calculate the required capacitance C_{SS} from the following equation:

$$C_{SS} = TSS \times \left(\frac{10\mu A}{0.6V} \right)$$

Feed-Forward Capacitor (C_{FF})

A feed-forward capacitor (C_{FF}) may be necessary depending on the Equivalent Series Resistance (ESR) of C_{OUT} . If only ceramic output capacitors are used for C_{OUT} then a C_{FF} is necessary. Calculate C_{FF} from:

$$C_{FF} = \frac{1}{2 \times \pi \times R1 \times 7 \times f_{LC}}$$

where:

$R1$ is the resistor that C_{FF} is placed in parallel with

f_{LC} is the frequency of output filter double-pole

f_{LC} must be less than 11kHz when using ceramic C_{OUT} . If necessary, increase C_{OUT} and/or L in order to meet this constraint.

When using capacitors with higher ESR, such as PANASONIC TPE series, a C_{FF} is not required provided following conditions are met:

1. The frequency of output filter LC double-pole f_{LC} should be less than 10kHz.
2. The frequency of ESR Zero $f_{Zero,ESR}$ should be at least five times larger than f_{LC} .

Note that if $f_{Zero,ESR}$ is less than $5f_{LC}$, then it is recommended to set the f_{LC} at less than 2kHz. C_{FF} is still not required.

Feed-Forward Resistor (R_{FF})

Poor PCB layout and/or extremely fast switching FETs can cause switching noise at the output and may couple to the FB pin via C_{FF} . Excessive noise at FB will cause poor load regulation. To solve this problem place a resistor R_{FF} in series with C_{FF} . R_{FF} value up to 2% of $R1$ is acceptable.

Maximum Allowable Voltage Ripple at FB pin

Note that the steady-state voltage ripple at feedback pin FB ($V_{FB,RIPPLE}$) must not exceed 50mV in order for the Module to function correctly. If $V_{FB,RIPPLE}$ is larger than 50mV then C_{OUT} should be increased as necessary in order to keep the $V_{FB,RIPPLE}$ below 50mV.

Application Circuit

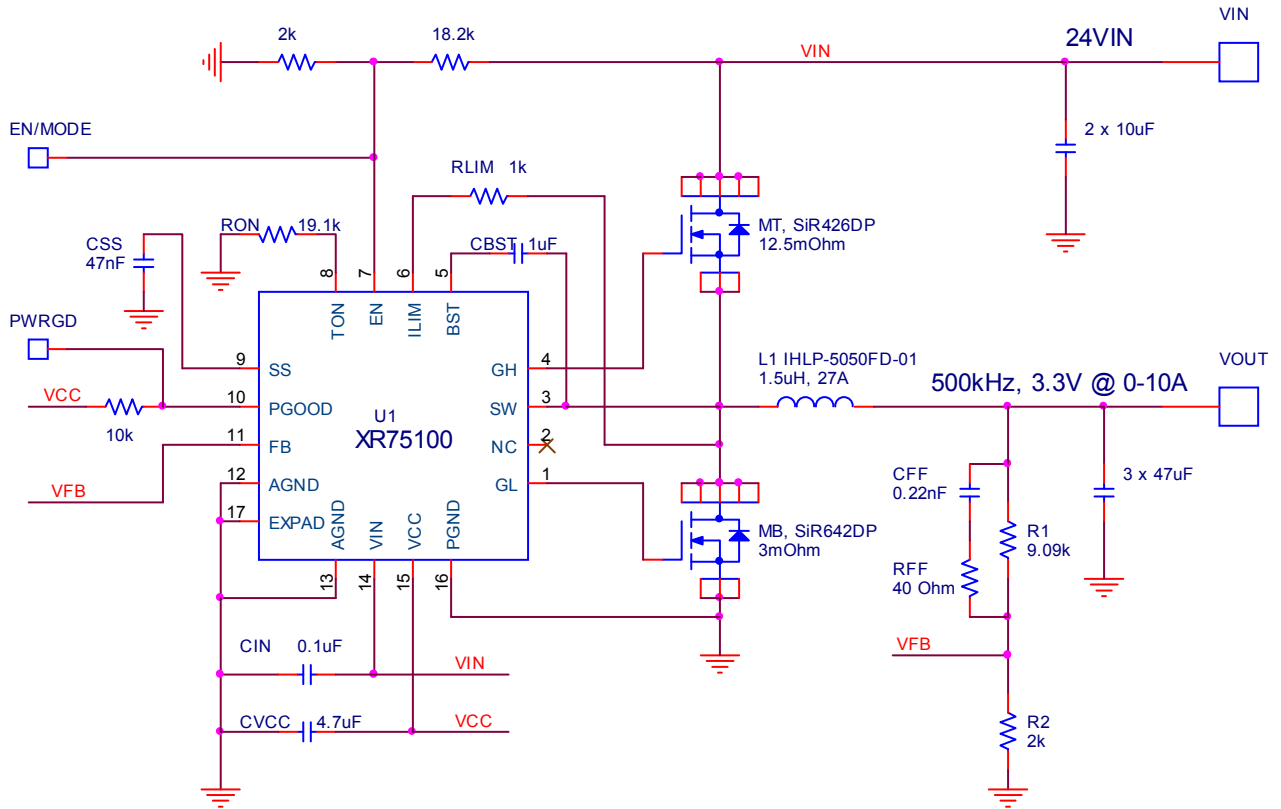

Mechanical Dimensions

16-Pin QFN

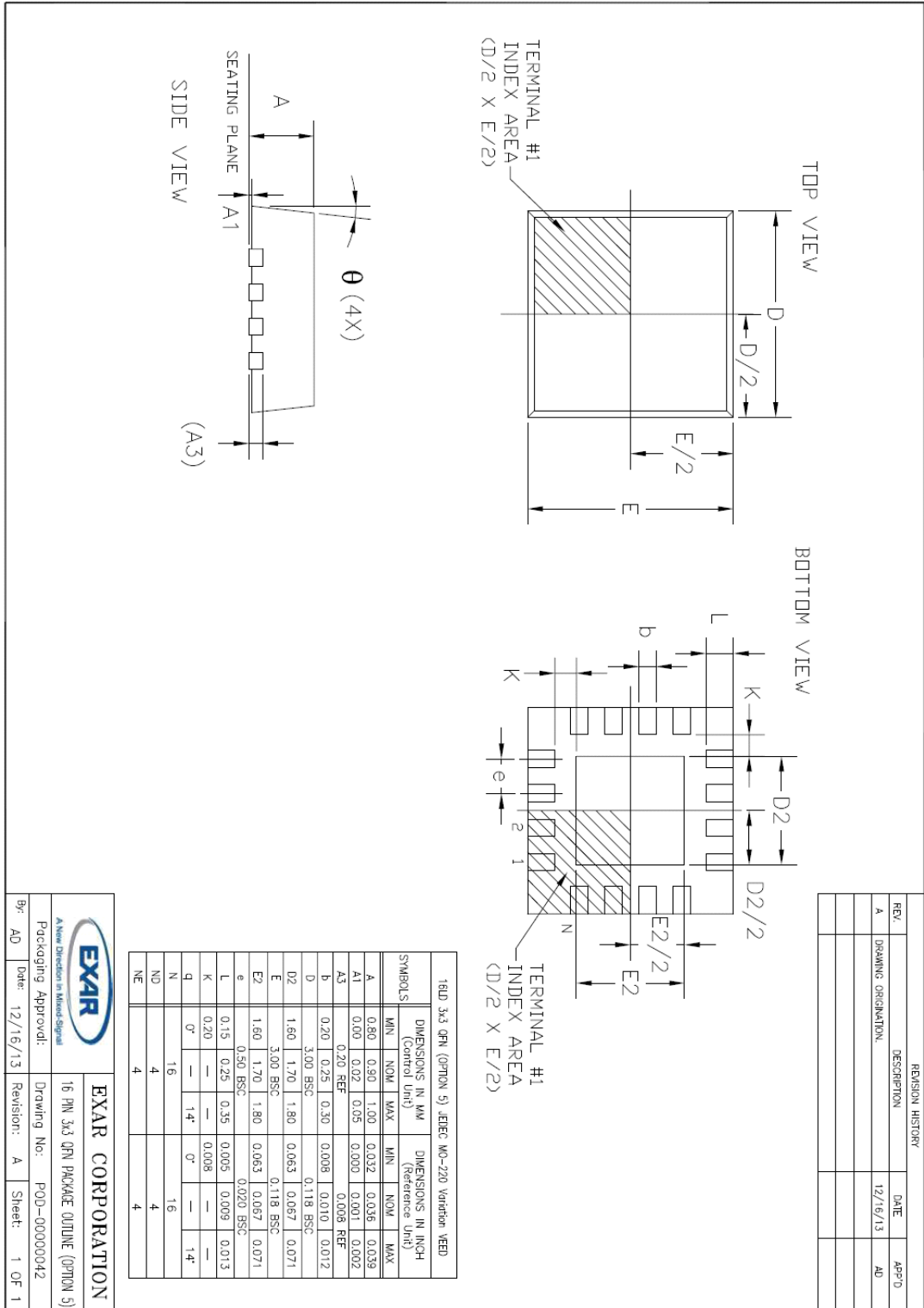

REVISION HISTORY			
REV.	DESCRIPTION	DATE	APP'D
A	DRAWING ORIGINATOR	12/16/13	AD

		EXAR CORPORATION	
A New Direction in Mixed-Signal Packaging Approval:		16 PIN 3x3 QFN PACKAGE OUTLINE (OPTION 5)	
By: AD	Date: 12/16/13	Revision: A	Sheet: 1 OF 1

ECN: 1351-04 12/16/2013

Ordering Information

Part Number	Package	JEDEC Compliant	Operating Temperature Range	Packaging Quantity	Marking
XR75100EL-F	16-pin QFN	Yes	$-40^{\circ}\text{C} \leq T_J \leq +125^{\circ}\text{C}$	Bulk	75100 YYWWF XXXXX
XR75100ELMTR-F	16-pin QFN	Yes	$-40^{\circ}\text{C} \leq T_J \leq +125^{\circ}\text{C}$	250 / Reel	
XR75100ELTR-F	16-pin QFN	Yes	$-40^{\circ}\text{C} \leq T_J \leq +125^{\circ}\text{C}$	3000 / Reel	
XR75100EVB	Evaluation Board	N/A	N/A	N/A	N/A

“YY” = Year (last two digits)- “WW” = Work Week- “X” = Lot Number; when applicable

For Further Assistance:

Technical Support: techsupport.exar.com

Technical Documentation: www.exar.com/techdoc

Exar Corporation Headquarters and Sales Offices

48720 Kato Road Tel.: +1 (510) 668-7000
Fremont, CA 95438 - USA Fax: +1 (510) 668-7001



NOTICE

EXAR Corporation reserves the right to make changes to the products contained in this publication in order to improve design, performance or reliability. EXAR Corporation assumes no responsibility for the use of any circuits described herein, conveys no license under any patent or other right, and makes no representation that the circuits are free of patent infringement. Charts and schedules contained herein are only for illustration purposes and may vary depending upon a user's specific application. While the information in this publication has been carefully checked; no responsibility, however, is assumed for inaccuracies.

EXAR Corporation does not recommend the use of any of its products in life support applications where the failure or malfunction of the product can reasonably be expected to cause failure of the life support system or to significantly affect its safety or effectiveness. Products are not authorized for use in such applications unless EXAR Corporation receives, in writing, assurances to its satisfaction that: (a) the risk of injury or damage has been minimized; (b) the user assumes all such risks; (c) potential liability of EXAR Corporation is adequately protected under the circumstances.

Reproduction, in part or whole, without the prior written consent of EXAR Corporation is prohibited.