

YIC Quartz Crystal Unit (XT532/534 Series)

XT532,XT534 Series: SMD Crystal 5x3.2 2pad & 4pad

8.000 - 125.000MHz

● SPECIFICATION

Type	XT532 & XT534
Frequency Range	8.000 - 125.000MHz
Frequency Tolerance	± 10 , 20 , 30 PPM (at 25°C)
Frequency Stability	± 10 , 20 , 30 PPM (Ref. to 25°C)
Operation Temperature	-10°C ~ +70°C by Customer requirement
Storage Temperature	-40°C ~ +85°C
Load Capacitance	Series,9pF,10pF,12pF,15pF,18pF,20pF,30pF or Special requirement
Drive Level	15,30,50,100,200,500 μW or Special requirement
Series Resistance	See below
Shunt Capacitance	7pF max
Aging	±3PPM/year

● EQUIVALENT SERIES RESISTANCE

XT534

Frequency (MHz)	ESR (Ω)
Fundamental	
8.000 - 12.000MHz	100 max.
12.001 - 20.000MHz	40 max.
20.001 - 30.000MHz	40 max.
30.001 - 40.000MHz	40 max.
40.001 - 48.000MHz	40 max.
3rd Overtone	
40.000 - 60.000MHz	120 max.
60.000 - 100.000MHz	80 max.

XT532

Frequency (MHz)	ESR (Ω)
Fundamental	
8.000 - 40.000MHz	100 max.
40.000- 100.000MHz	120 max.

● TAPE SPECIFICATION(mm)

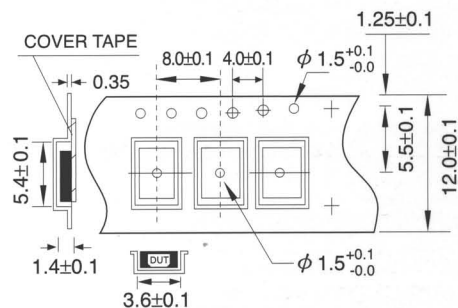

● DIMENSIONS(mm)

XT 532

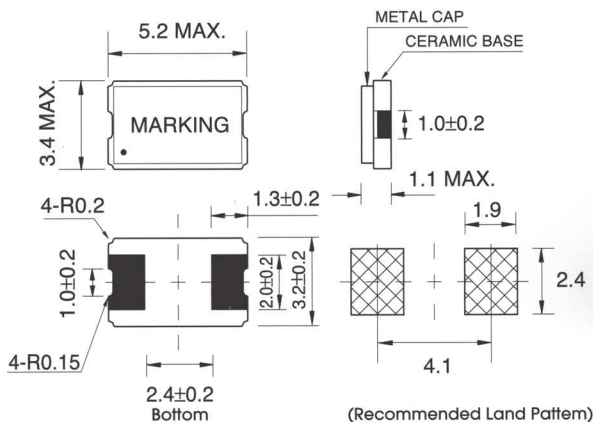

XT 534

