

CRYSTAL SPECIFICATION



Customer : 共濟企業股份有限公司

Customer P/N :

SIWARD P/N : XTL571200-A180-120

Customer Approval :

希華晶體科技股份有限公司
SIWARD CRYSTAL TECHNOLOGY CO., LTD.

業務部/ SALE DEPARTMENT
TEL: (04)25347909
FAX: (04)25327885 / 25337396
URL HTTP://www.siward.com.tw

DATE : 2012/06/13

Approved By : *Steve Chen*

品質保證部/ QUALITY ASSURANCE DEPT.
TEL: (04)25347909 EXT 1340/1341

Checked By : *Tom Tang*

研發部/R & D DEPT.
TEL: (04)25347909 EXT 1521

Designer : *Sally Lin*

Address: 1-1, LANE 111, JUNG-SHAN RD., SEC.3, TANTZU HSING, TAICHUNG 427, TAIWAN, R.O.C.

Rev.	Description of Revision History	Date	Designer	Checked By
1	New Publication	2007/11/15	Sally Lin	Tom Tang

CRYSTAL SPECIFICATION

- 1. Description : Quartz Crystal
 - 2. Nominal Frequency : 18.432000 MHz
 - 3. Center Frequency : 18.432000 MHz
 - 4. Dimension & Drawing No. : SX-3225 ; SXD-00213
 - 5. Oscillation Mode : Fundamental
 - 6. Cutting Mode : AT cut
 - 7. Packing Style : TP-094
 - 8. Measurement Instrument : S&A 250B(Measured FL)
 - 9. Electrical Characteristics :
- [1] Operating Conditions :

Item	Symbol	MIN.	TYP.	MAX.	Unit	Condition
Operating Temperature Range	Topt	-20		70	°C	
Storage Temperature Range	Tstg	-40		90	°C	
Load Capacitance	CL		18		pF	
Drive Level	DL			100	μW	

[2] Frequency Stability :

Item	Symbol	MIN.	TYP.	MAX.	Unit	Condition
Tolerance	dF/Fo	-20		20	ppm	Refer to Center Frequency @25±3°C
Stability Over Temperature	dF/F25	-20		20	ppm	Refer to Operating Temperature
Aging	dF/F25	-3		3	ppm	Per Year

dF/Fo: Frequency Deviation Refer to Center Frequency

dF/F25: Frequency Deviation Refer to 25 °C Frequency

[3] Electrical Performance :

Item	Symbol	MIN.	TYP.	MAX.	Unit	Condition
Equivalent Series Resistance	ESR			100	Ω	@Series
Shunt Capacitance	Co			5	pF	
Insulation Resistance	IR	500			M Ω	@DC 100 Volt

10. Marking : Laser

<p>*MARKING : D ->YEAR C -> MONTH YEAR : 1 2 3 4 5 6 7 8 9 0 CODE : A B C D E F G H J K MONTH: 1 2 3 4 5 6 7 8 9 10 11 12 CODE : A B C D E F G H J K L M</p>	<div style="border: 1px solid black; padding: 10px; width: 150px; margin: auto;"> <p>18.4</p> <p>S DC</p> </div>
--	--

11. Remark :

<p>*Lead Free, RoHS compliant</p>

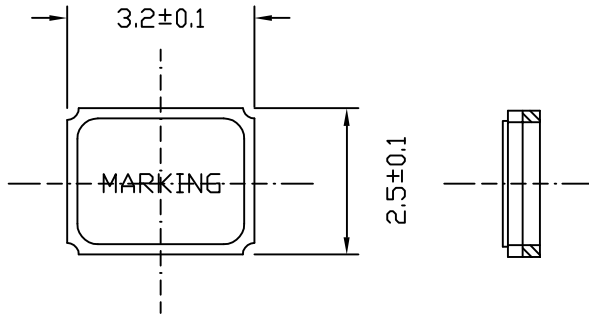

PIN CONNECT	
1,3	Crystal
2,4	GND

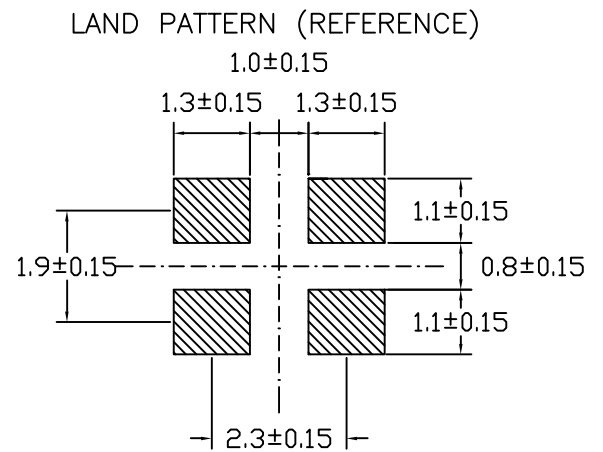
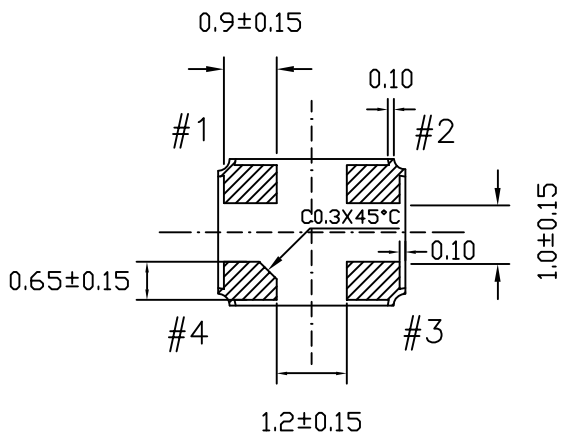
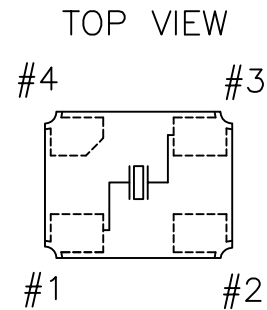
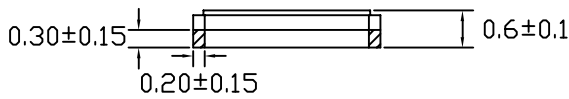

3	ADD PIN CONNECT	'11.03.04	DRAWING NAME	SX-3225 (XTL57)		
2	ADD MARKING	'05.09.28	DRAWING NO.	SXD-00213		
1	NEW EDITION	'04.03.26	SCALE		UNIT	mm
NO.	MODIFY CONTENTS	DATE	APPROVE	<i>Jason</i>	DESIGNER	<i>John</i>

1.CARRIER TYPE

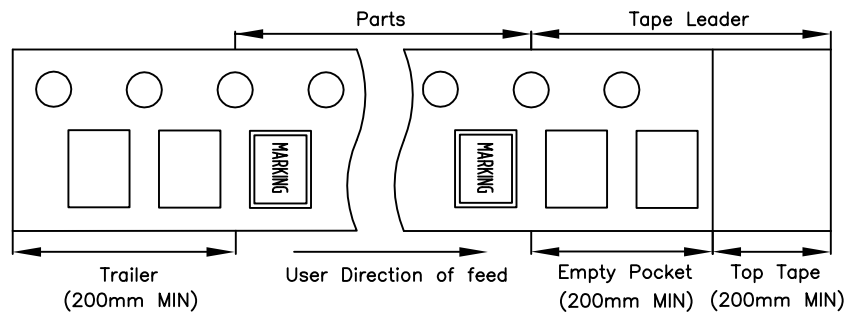
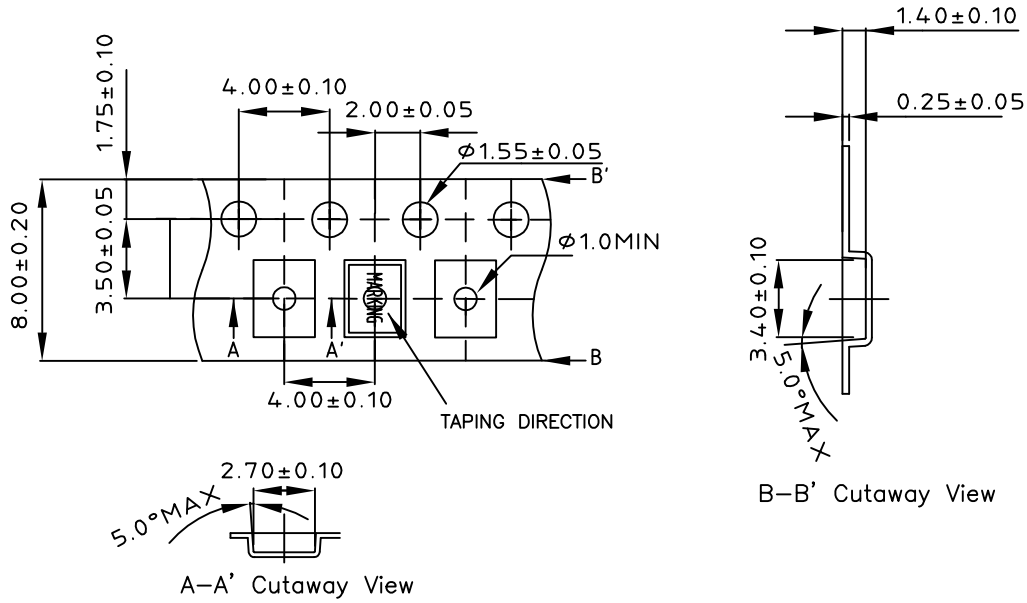

2.REEL : 3000PCS

C.ENLARGE

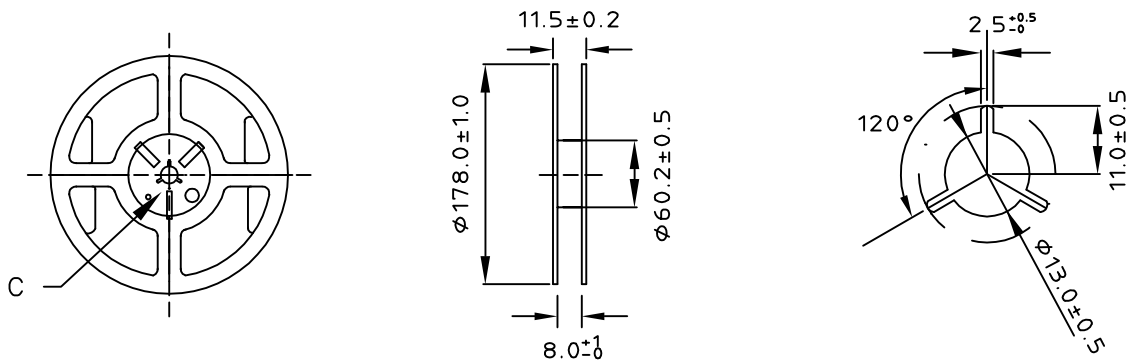

4	ORIGIN REEL : 3000PCS OR 1000PCS DELETE BOX AND CARTON	'10.06.01	DRAWING NAME	SX-3225 REEL PACKING		
2	MODIFY (101A0408-005)	'04.08.06	DRAWING NO.	TP-094		
1	NEW EDITION	'03.06.23	SCALE		UNIT	mm
NO.	MODIFY CONTENTS	DATE	APPROVE	<i>Tkanno</i>	DESIGNER	<i>Jane</i>

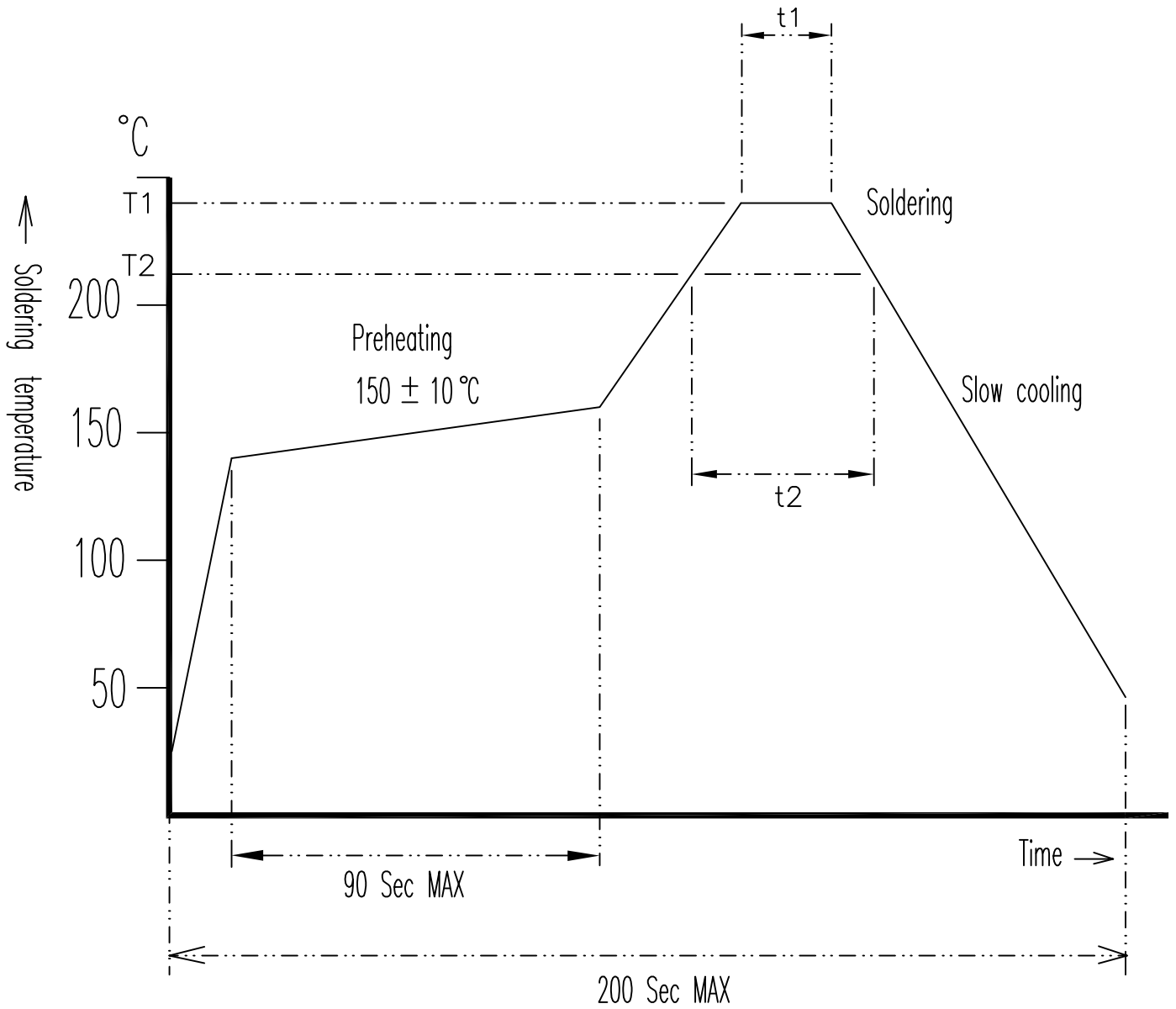

Application	Temperature/Time	T1/t1	T2/t2
Lead Free		260±5°C/10 Sec Max	225°C Min/60 Ses Max
Non Lead Free		240±5°C/10 Sec Max	200°C Min/40 Sec Max

5	MODIFY DRAWING NAME	'07.07.06	DRAWING NAME	QUARTZ DEVICE SMD REFLOW CHART		
4	ADD 225 °C Min/60 Sec Max	'06.06.13	DRAWING NO.	FLOW-004		
1	NEW ISSUANCE	'99.12.10	SCALE		UNIT	
NO.	MODIFY CONTENTS	DATE	APPROVE	<i>Cat</i>	DESIGNER	<i>Olive</i>