

Dual High-Efficiency PWM Step-Down DC/DC Converter

GENERAL DESCRIPTION

The XU5122 is a dual high-efficiency PWM step-down DC-DC converter. It is capable of delivering 700mA output each channel over a wide input voltage from 2.5V to 5.5V, the XU5122 is ideally suited for portable electronic devices that are powered from 1-cell Li-ion battery or from other power sources within the range such as cellular phones, PDAs and other handheld devices. The switching ripple is easily smoothed-out by small package filtering elements due to a fixed operation frequency of 1.5MHz. This along with small WDFN-12L 3X3 package provides small PCB area application. Other features include soft start, lower internal reference voltage with 2% accuracy, over temperature protection, and over current protection.

FEATURES FOR EACH CHANNEL

- 700mA Output Current
- High Efficiency up to 95%
- 2.5V to 5.5V Input Range
- Low Quiescent Current 130uA
- Adjustable Output from 0.6V to VIN
- No Schottky Diode Required
- 1.5MHz Constant Frequency Operation
- Low Dropout Operation: 100% Duty Cycle
- Small 12-Lead WDFN Package
- RoHS Compliant and 100% Lead(Pb)-Free

APPLICATIONS

- Personal Information Appliances
- Mobile Phones
- Wireless and DSL Modems
- Portable Instruments

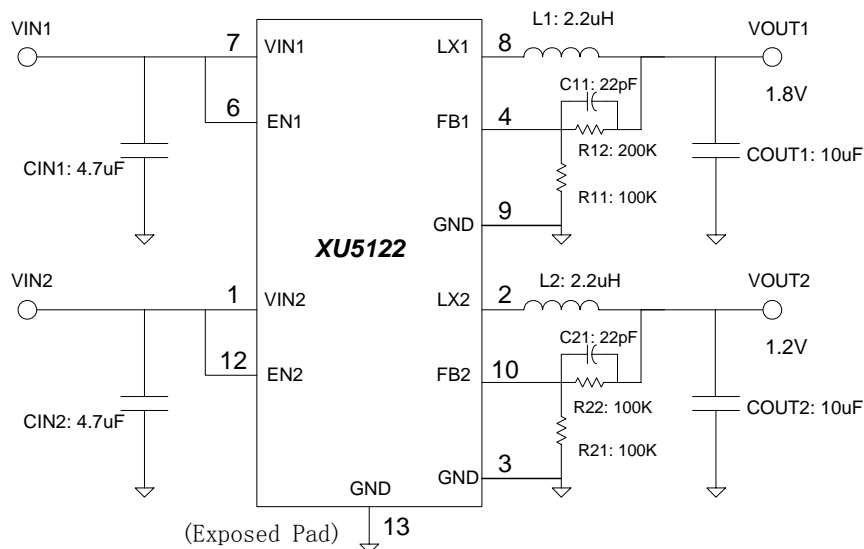

Figure 1. Typical Application Circuit for Adjustable Version

ORDERING INFORMATION

PART NUMBER	TEMP RANGE	SWICHING FREQUENCY	OUTPUT VOLTAGE (V)	OUTPUT CURRENT (A)	PACKAG E	PINS
XU5122AA	-40°C to 85°C	1.5MHz	Adjustable	0.7	DFN	12

PIN CONFIGURATION

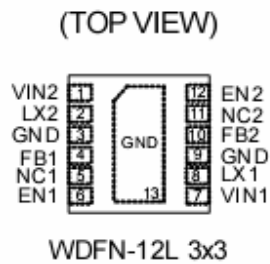

Figure 2. PIN Configuration

PIN DESCRIPTION

PIN NUMBER	PIN NAME	PIN DESCRIPTION
1	VIN2	Power Input of Channel 2.
2	LX2	Pin for Switching of Channel 2.
3,9,13(Exposed-Pad)	GND	Ground. The exposed pad must be soldered to a large PCB and connected to GND for maximum power dissipation.
4	FB1	Feedback of Channel 1.
5,11	NC1,NC2	No Connection
6	EN1	Enable of Channel 1(Active High).
7	VIN1	Power Input of Channel 1.
8	LX1	Pin for Switch of Channel 1.
10	FB2	Feedback of Channel 2
12	EN2	Enable of Channel 2(Active High).

ABSOLUTE MAXIMUM RATINGS

(Note: Do not exceed these limits to prevent damage to the device. Exposure to absolute maximum rating conditions for long periods may affect device reliability.)

PARAMETER	VALUE	UNIT
Supply Voltage VIN1	-0.3 to 6.0	V
FB, EN Voltage	-0.3 to VIN+0.3	V
LX Voltage	-0.3 to VIN+0.3	V
Operating Ambient Temperature	-40 to 85	°C
Maximum Junction Temperature	125	°C
Storage Temperature	-65 to 150	°C
Lead Temperature (Soldering, 10 sec)	300	°C
Power Dissipation	1.667	W

ELECTRICAL CHARACTERISTICS

(For each output channel, $V_{IN} = 3.6V$, $V_{REF} = 0.6V$, $L = 2.2\mu H$, $C_{IN} = 2.2\mu H$, $V_{OUT} = 10\mu F$, $T_A = 25^\circ C$ unless otherwise specified)

PARAMETER	SYMBOL	TEST CONDITIONS	MIN	TYP	MAX	UNIT
CHANNEL 1 AND CHANNEL 2						
Input Voltage Range	V_{IN}		2.5		5.5	V
UVLO Threshold	V_{UVLO}	$V_{HYSTERESIS} = 100mV$	2.3	2.45	2.5	V
Operating Supply Current	I_{SUPPLY}	$V_{FB} = 0.5V$ or $V_{OUT} = 90%$, $I_{Load} = 0$		130	170	μA
Shutdown Supply Current		$V_{EN} = 0V$, $V_{IN} = 4.2V$		0.1	1	
Regulated Feedback Voltage	V_{FB}	$T_a = 25^\circ C$	0.588	0.6	0.612	V
		$0 < T_a < 85^\circ C$	0.5865	0.6	0.6135	
		$-40^\circ C < T_a < 85^\circ C$	0.585	0.6	0.615	
Reference Voltage Line Regulation		$V_{IN} = 2.7V$ to $5.5V$		0.04	0.4	%
Regulated Output Voltage	V_{OUT}	$V_{OUT} = 1.8V$; $I_{OUT} = 100mA$	1.746	1.8	1.854	V
Peak Inductor Current	I_{PEAK}	$V_{IN} = 3V$, $V_{FB} = 0.5V$ or $V_{OUT} = 90%$, Duty Cycle $< 35%$		1		A
Oscillator Frequency	F_{OSC}	$V_{FB} = 0.6V$ or $V_{OUT} = 100%$	1.2	1.5	1.8	MHz
		$V_{FB} = 0$ or $V_{OUT} = 0$		220		KHz
Rds(ON) of P-channel FET		$I_{SW} = 100mA$		0.15	0.3	Ohm

Rds(ON) of N-channel FET		$I_{SW} = -100mA$		0.15	0.3	Ohm
Enable Threshold		$V_{IN} = 2.5V$ to $5.5V$	0.3	1	1.5	V
Enable Leakage Current			-0.1		0.1	μA
LX Leakage Current		$V_{EN} = 0V$, $V_{SW} = 0V$ or $5V$, $V_{IN} = 5V$	-1		1	μA
Maximum Duty Cycle			100			%

FUNCTION BLOCK DIAGRAM

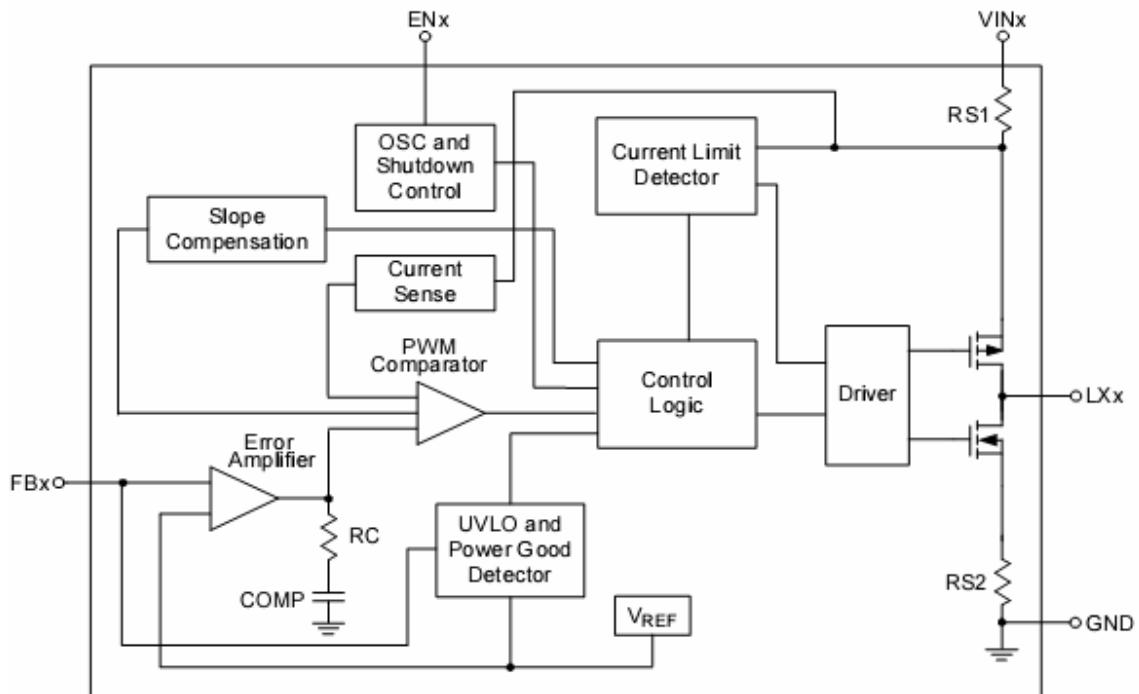

Figure 3. Functional Block Diagram

APPLICATION INFORMATION

INDUCTOR SELECTION

In normal operation, the inductor maintains continuous current to the output. The inductor current has a ripple that is dependent on the inductance value. The high inductance reduces the ripple current. In general, select the inductance by the following equation:

$$L = \frac{V_{OUT} \times (V_{IN} - V_{OUT})}{V_{IN} \cdot f \cdot \Delta I}$$

Where V_{OUT} is the output voltage, V_{IN} is the input voltage, f is the switch frequency, and ΔI is the peak-to-peak inductor ripple current. Typically, choose ΔI as the 30% of the maximum output current.

Manufacturer	Part Number	Inductance (uH)	DRC max (Ohms)	Dimensions L*W*H(mm3)
Murata	LQH32PN	2.2	0.09	3.2*2.5*1.7
		4.7	0.15	
Sumida	CDRH3D16	2.2	0.07	4*4*1.8
		4.7	0.16	

Table 1. Recommend Surface Mount Inductors

INPUT CAPACITOR SELECTION

The input capacitor reduces input voltage ripple to the converter, low ESR ceramic capacitor is highly recommended. For most applications, a 4.7uF capacitor is used. The input capacitor should be placed as close as possible to VIN and GND.

OUTPUT CAPACITOR SELECTION

A low ESR output capacitor is required in order to maintain low output voltage ripple. In the case of ceramic output capacitors, capacitor ESR is very small and does not contribute to the ripple, so a lower capacitance value is acceptable when ceramic capacitors are used. A 10uF ceramic output capacitor is suitable for most applications.

OUTPUT VOLTAGE PROGRAMMING

In the adjustable version, the output voltage is set by a resistive divider according to the following equation:

$$R_2 = R_1 \times \left(\frac{V_{OUT}}{0.6} - 1 \right)$$

Typically choose R1=100K and determine R2 from the following equation:

Connect a small capacitor across R1 feed forward capacitance at the FB pin for better performance.

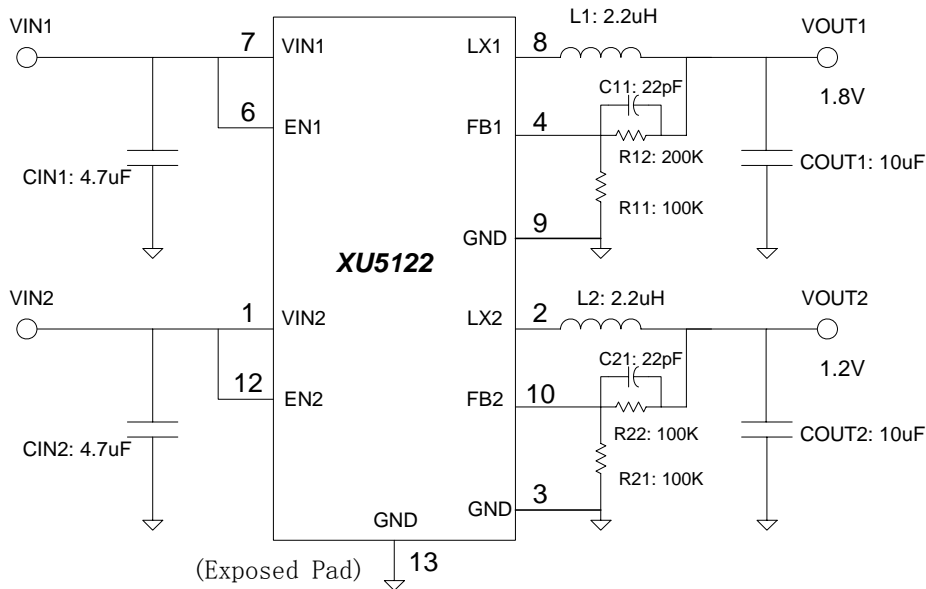
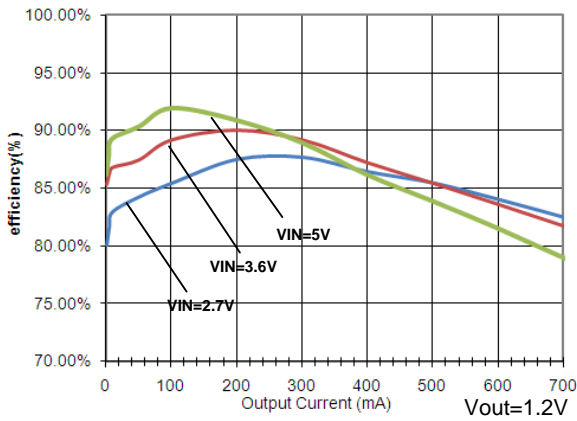

Figure 4. Typical Application Circuit for Adjustable Version

TYPICAL PERFORMANCE CHARACTERISTICS

(VIN=VEN=3.6V, L=2.2uH, CIN=4.7uF, COU=10uF)

Efficiency vs. Output Current



Steady State Waveform

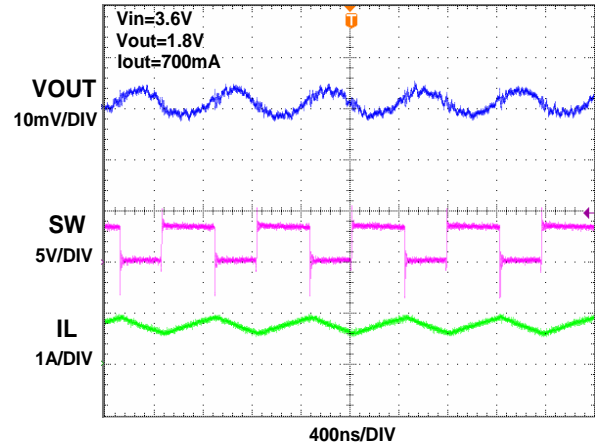

Oscillator Frequency vs. Temperature

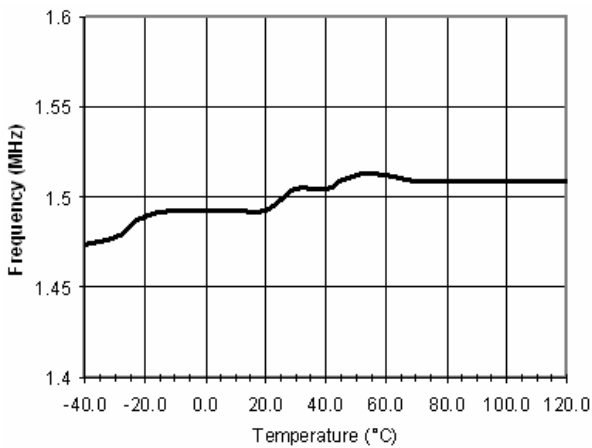

Load Transient Waveform

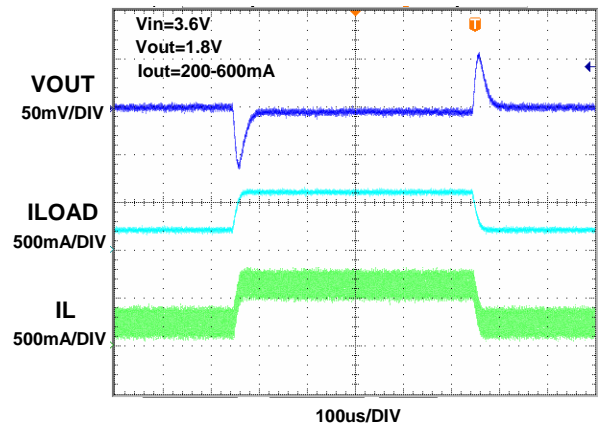

Reference Voltage vs. Temperature

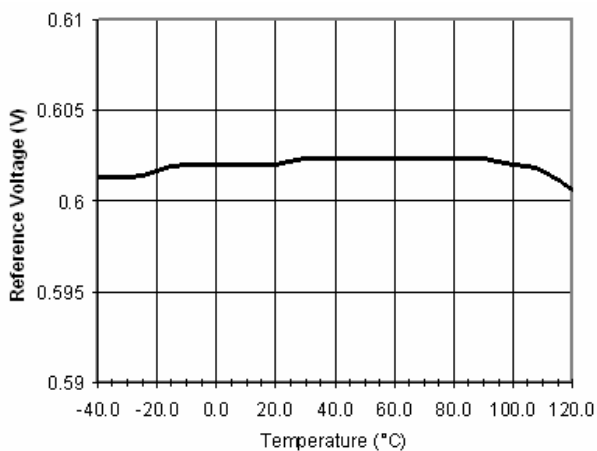

Startup through Enable Waveform

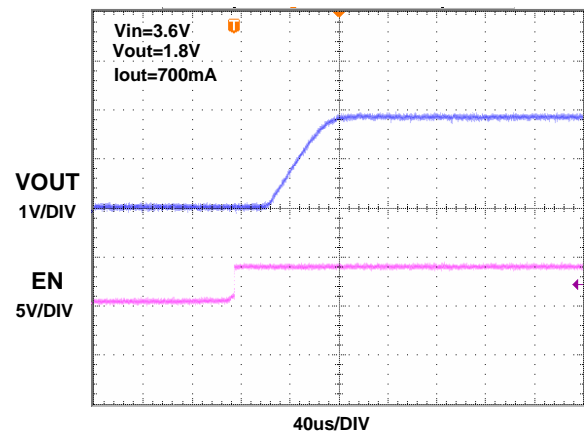

PACKAGE OUTLINE

DFN12 3MM X 3MM PACKAGE OUTLINE AND DIMENSIONS

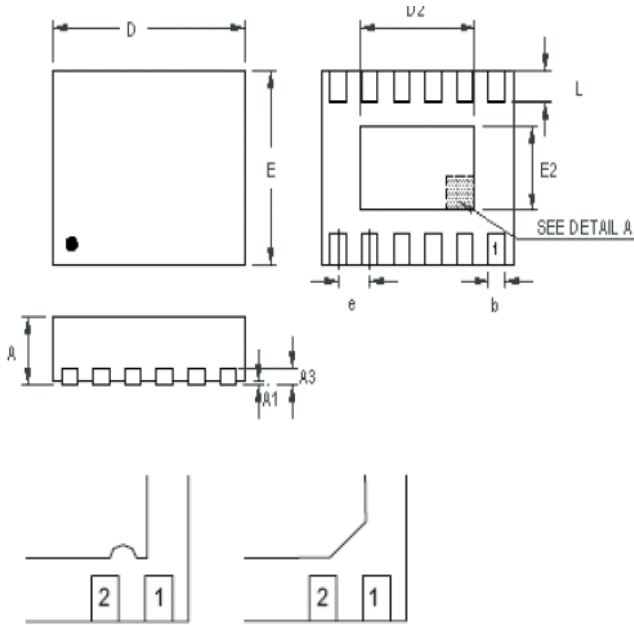

SYMBOL	DIMENSION IN MILLIMETERS		DIMENSION IN INCHES	
	MIN	MAX	MIN	MAX
A	0.700	0.800	0.028	0.031
A1	0.000	0.050	0.000	0.002
A3	0.175	0.250	0.007	0.010
b	0.150	0.250	0.006	0.010
D	2.950	3.050	0.116	0.120
D2	2.300	2.650	0.091	0.104
E	2.950	3.050	0.116	0.120
E2	1.400	1.750	0.055	0.069
e	0.450		0.018	
L	0.035	0.450	0.014	0.018

DETAIL A

PIN #1 ID and Tie Bar Mark Options