

SPECIFICATION FOR LCD MODULE

MODULE NO: YB-TG1280800S07A-N-A0

Doc.Version:01

Customer Approval:

<input type="checkbox"/> Accept	<input type="checkbox"/> Reject
---------------------------------	---------------------------------

YEEBO	NAME	SIGNATURE	DATE
Prepare	Electronic Engineer	邓茗刚	2018/10/17
Check	Mechanical Engineer	丁百益	2018/10/17
Verify		丁百益	2018/10/17
Approval		丁百益	2018/10/17

APPROVAL FOR SPECIFICATIONS ONLY

APPROVAL FOR SPECIFICATIONS AND SAMPLE

WIMRD005-02-D

1. Revision History

Sample Version	DOC. Version	DATE	DESCRIPTION		CHANGED BY
A0	00	2018-09-30	Spec only	First issue	D.M.G /Allenson
A0	01	2018-10-17	Spec only	1. Modify LED Life time to 50000hr (Min)P15	D.M.G /Allenson

2. Table of Contents:

NO	CONTENTS	PAGE
1	Revision History	1
2	Table of Contents	2
3	Module Numbering System	3
4	General Specification	4
5	LCM drawing	5
6	Electrical Characteristics	7
7	Optical Characteristics	11
8	Interface Pin Assignment	13
9	Backlight Characteristics	15
10	Standard Specification for Reliability	16
11	Specification of Quality Assurance	18
12	Handling Precaution	26
13	Guarantee	26

3. Module Numbering System:

(Example)

YB- T G 240320 S 01 D -T - A0

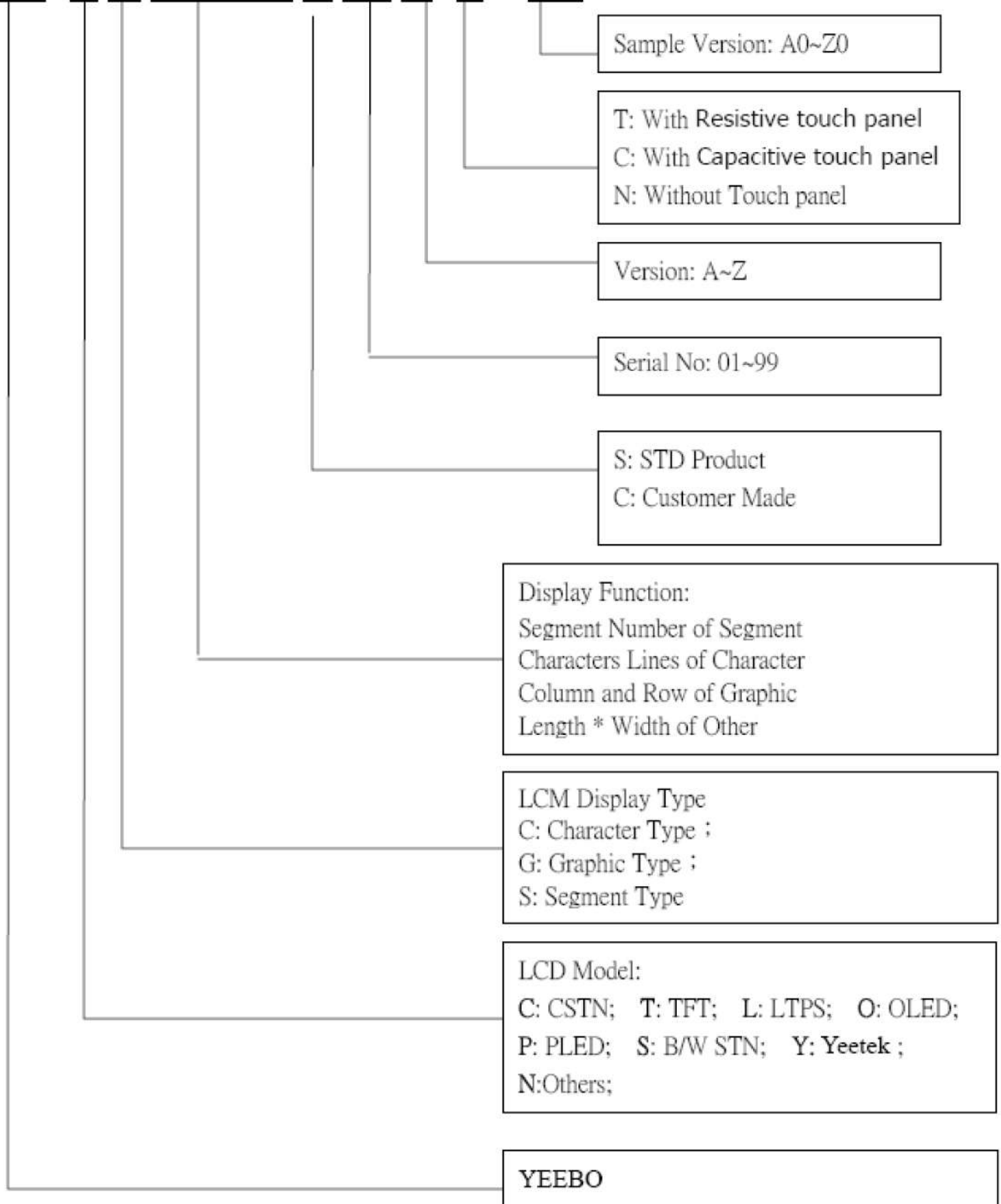

4. General Specification:

ITEM	CONTENTS
Module Size	229.46 (W) *149.1 (H) *2.55 (T) mm
Module Size(With FPC)	229.46 (W) *150.1 (H) *4.6 (T) mm
Display Size(Diagonal)	10.1 inch
Display Format	1280(RGB) * 800 Pixels
Active Area	216.96(W) * 135.6(H) mm
Pixel Pitch	0.1695 * 0.1695 mm
LCD Type	TFT(16.7M) / Transmissive / Normal Black / Glare
View Direction	Free
Interface	LVDS
IC	HX8288*4 & HX8695*1
Weight	TBD

5. LCM drawing:

Count drawing & Spec revision record during discussion with customer	
Rec. #1	Revision content description
	FIRST ISSUE
Date	2018-09-29

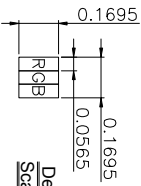
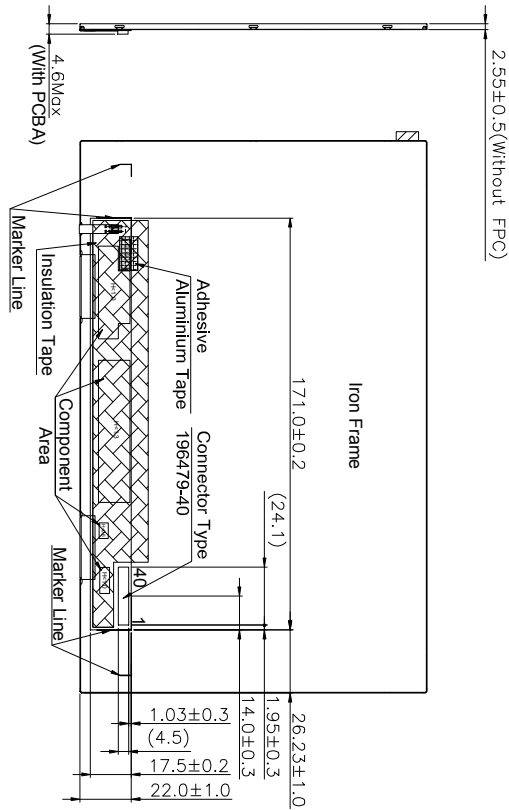
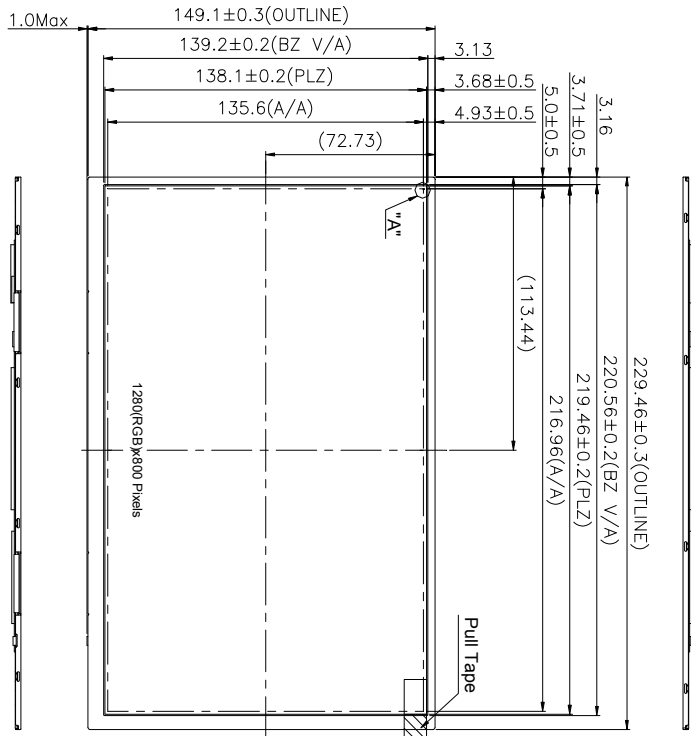

Detail: "A"

Scale:100X

- Specification:**
1. Display mode: 10.1" TFT / Transmissive / Normally Black
 2. Viewing Direction: Free
 3. Controller IC: HX8288-A02 & HX8695-B01
 4. Operating temperature: -20°C to +70°C
 5. Storage temperature: -30°C to +80°C
 6. Backlight: 49 chips White LED
 7. ROHS compliant

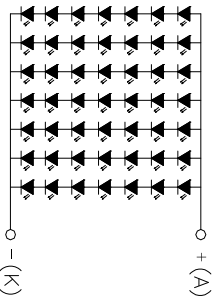

		UNIT	SIZE	SCALE	DESIGNED	CHECKED	VERIFIED	APPROVED	FILE NAME
		mm	A4	N-T-S	王琬琳				Count Dwg.
MOD. Name	YB-TG1280800S07A-N-A								
DESIGNED	王琬琳	2018-09-29							
CHECKED									
VERIFIED									
APPROVED									
Sheet	1								
Of	1								

No.	Symbol	PIN ASSIGNMENT
1	VCOM	
2	VDD	
3	VDD	
4	NC	
5	NC	
6	NC	
7	GND	
8	RXIN0-	
9	RXIN0+	
10	GND	
11	RXIN1-	
12	RXIN1+	
13	GND	
14	RXIN2-	
15	RXIN2+	
16	GND	
17	RXCLKIN-	
18	RXCLKIN+	
19	GND	
20	RXIN3-	
21	RXIN3+	
22	GND	
23	NC	
24	NC	
25	GND	
26	NC	
27	LED_PWM	
28	NC	
29	NC	
30	GND	
31	LED-	
32	LED-	
33	NC	
34	NC	
35	NC	
36	NC	
37	CABC_EN	
38	NC	
39	LED+	
40	LED+	

6. Electrical Characteristics

6-1 Absolute Maximum Ratings

(Ta=25°C VSS=0V)

Item	Symbol	Min.	Type	Max.	Unit	Remark
Power Supply voltage	VDD	-0.3	-	3.9	Volt	-
Operating Temperature	Topr	-20	-	+70	°C	-
Storage Temperature	Tstg	-30	-	+80	°C	-

Note : The absolute maximum rating values of this product are not allowed to be exceeded at any times. Should a module be used with any of the absolute maximum ratings exceeded, the characteristics of the module may not be recovered, or in an extreme case, the module may be permanently destroyed.

6-2 Operating Conditions

(Ta=25°C)

Item	Symbol	Min.	Typ.	Max.	Unit	Remark
Power Supply voltage	VDD	2.3	2.5	2.7	Volt	Note 2
Input signal voltage	VCOM	2.7	3.0	3.3	Volt	Note 4
Input logic high voltage	V _{IH}	0.8 VDD	-	3.6	Volt	Note 3
Input logic low voltage	V _{IL}	0	-	0.2 DVDD	Volt	

Note : Be sure to apply VDD and V_{GL} to the LCD first, and then apply V_{GH}.

Note 2: VDD setting should match the signals output voltage (refer to Note 3) of customer's system board.

Note 4: Typical VCOM is only a reference value, it must be optimized according to each LCM. Be sure to use VR.

6-3 Current Consumption

Item	Symbol	Min.	Typ.	Max.	Unit	Remark
Current for Driver	I _{VDD}	-	315	365	mA	V _{DD} =2.5V

6-4 LVDS Receiver

6-4-1 Signal Electrical Characteristics For LVDS Receiver

Parameter	Symbol	Min.	Typ.	Max.	Unit	Conditions
Differential Input High	Vth	-	-	+100	mV	V _{CM} =1.2V
Differential Input Low	Vtl	-100	-	-	mV	V _{CM} =1.2V
Magnitude Differential Input	V _{ID}	200	-	600	mV	-
Common Mode Voltage	V _{CM}	0.7	-	1.6	V	-

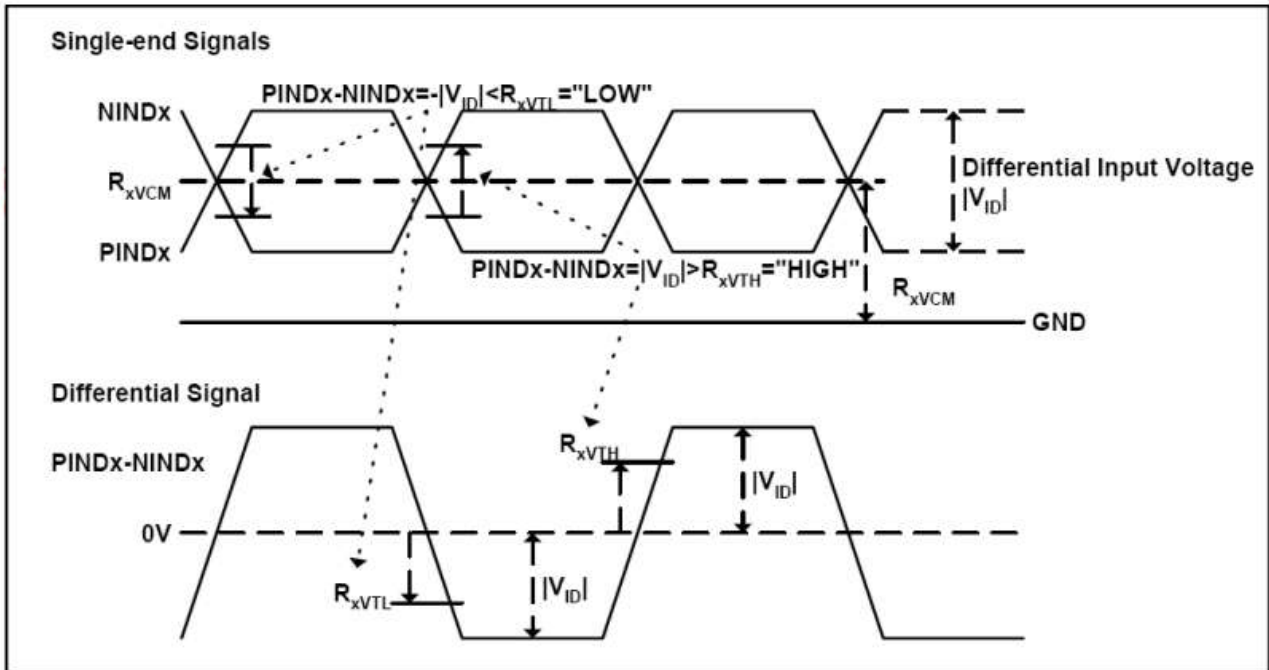

6-4-2 LVDS Data Input Format

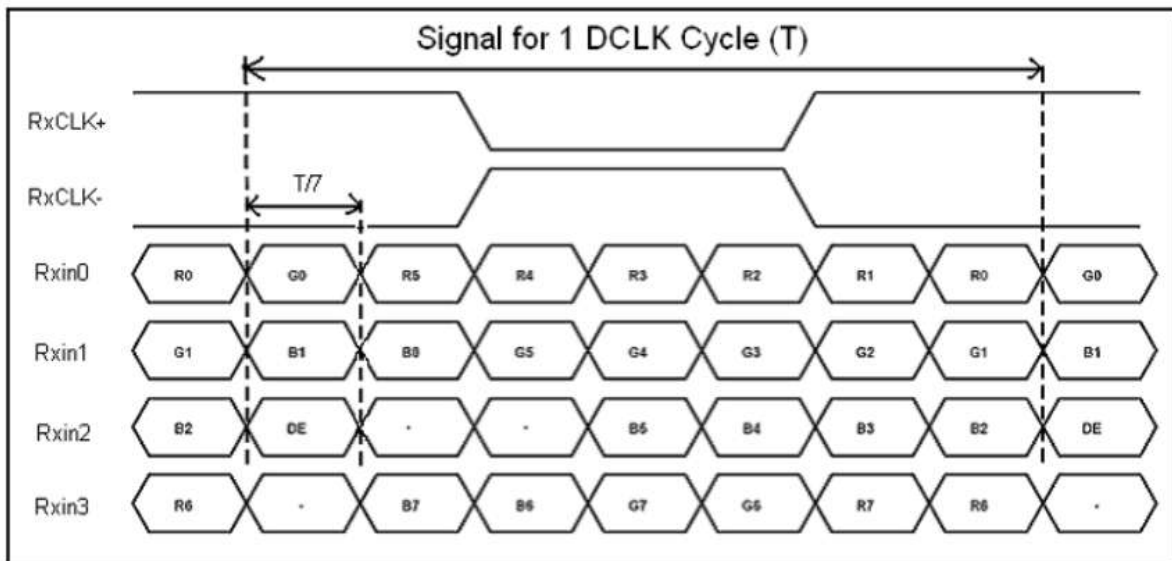

6-5 Interface Timing

6-5-1 Timing Characteristics

Interface Timings

Parameter	Symbol	Unit	Min.	Typ.	Max.
Frame Period	tV	line	(815)	(823)	(833)
Vertical display area	tVD	line	800		
VS Width +Back Porch +Front Porch	tVW+tVBP+tVFP	line	(15)	(23)	(33)
HS period time	tH	clock	(1410)	(1440)	(1470)
Horizontal Display Time	tHD	clock	1280		
HS Width +Back Porch +Front Porch	tHW+tHBP+tHFP	clock	(60)	(160)	(190)
Clock Rate	1/TC	MHz	(68.9)	(71.1)	(73.4)

Note: Frame rate is 60±5Hz, PCLK=Vtotal*Htotal*Frame Rate

6-5-2 Timing Diagram of Interface Signal(DE mode)

Timing Characteristics

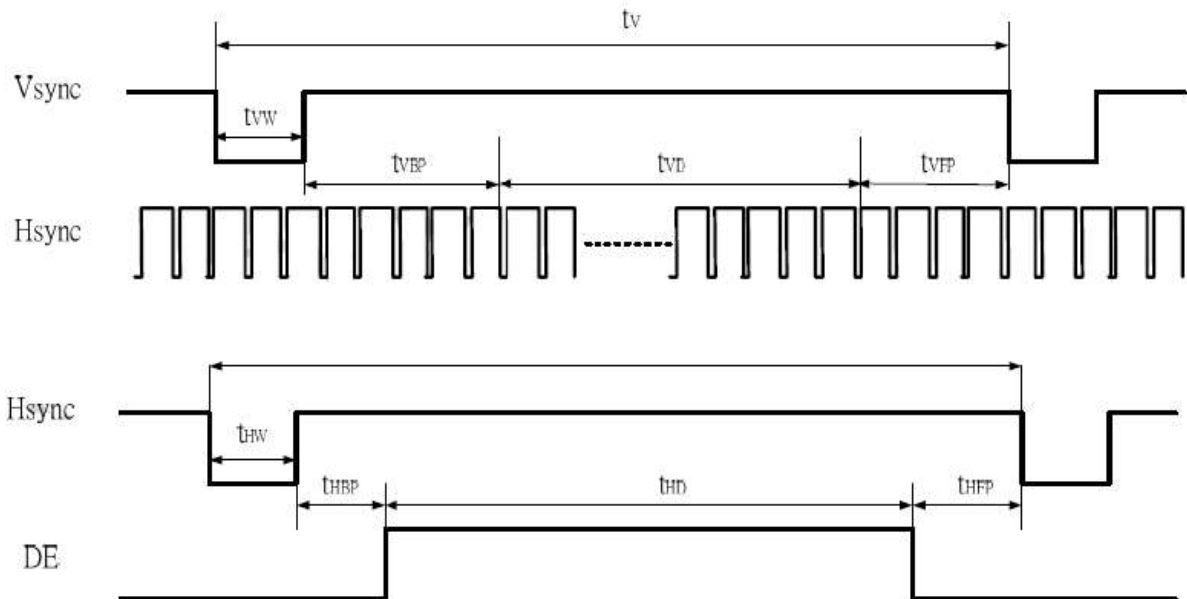

6-6 Power Sequence

a. Power on:

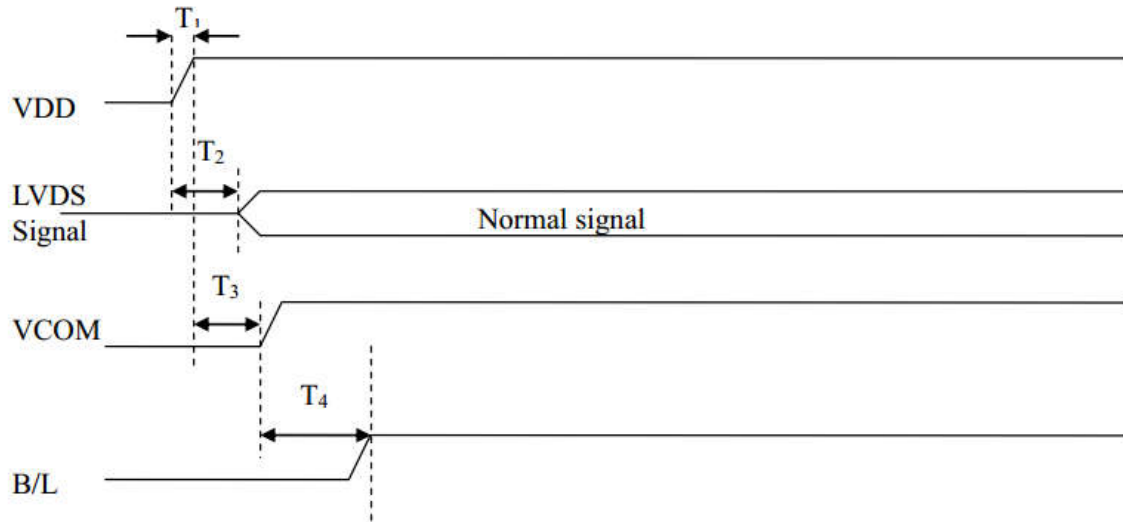

Symbol	Value			Unit
	Min.	Typ.	Max.	
T1	0.5	2	10	ms
T2	0	5	50	ms
T3	0	6	100	ms
T4	120	130	200	ms

b.Power off:

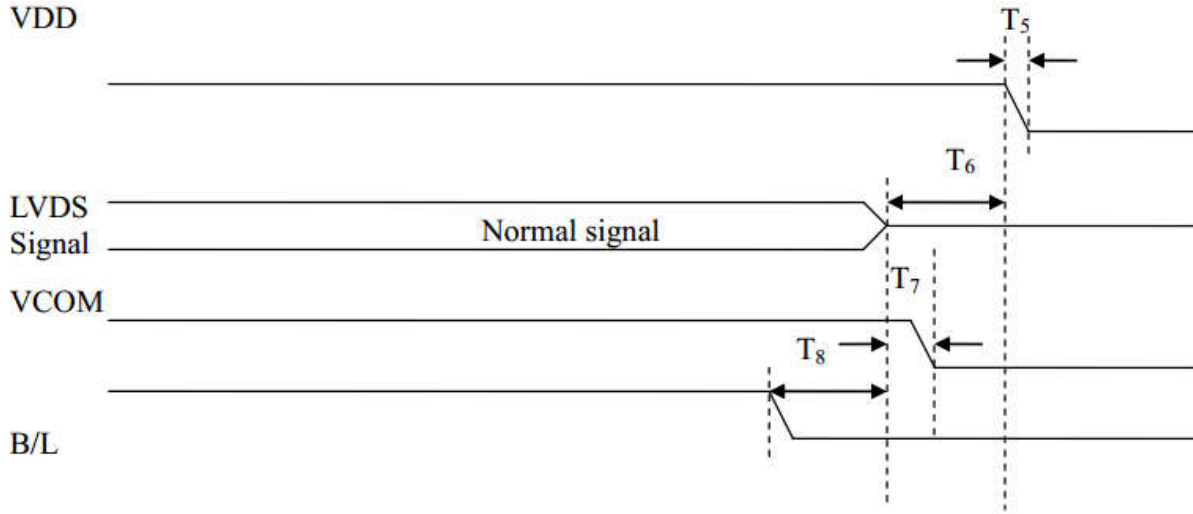

Symbol	Value			Unit
	Min.	Typ.	Max.	
T5	0.5	2	10	ms
T6	0	5	50	ms
T7	0	3	10	ms
T8	0	2	100	ms

7. Optical Characteristics:

Item	Symbol	Conditions	Specifications			Unit	Note	
			Min	Typ	Max			
Transmittance (With PLZ)	T(%)	-	4.8	5.4	-	%	-	
Contrast Ratio	CR	$\Theta=0$ Normal Viewing angle	600	800	-	-	(1) (2)	
Response time	TR+TF	-	-	25	50	ms	(1) (3)	
Viewing angle	Hor.	Θ_{x+}	CR ≥ 10	75	85	-	deg.	-
		Θ_{x-}		75	85	-		
	Ver.	Θ_{y+}		75	85	-		
		Θ_{y-}		75	85	-		

Measuring Condition

1. Measuring surrounding: dark room
2. Ambient temperature: $25 \pm 2^{\circ}\text{C}$
3. 30 min. Warm-up time.

Color of CIE Coordinate:

Item		Symbol	Condition	Min.	Typ.	Max.
Chromaticity Coordinates (Transmissive)	Red	x	$\theta = \phi = 0^{\circ}$ LED Backlight Color Degree	TBD	0.5860	TBD
		y		TBD	0.3547	TBD
	Green	x		TBD	0.3513	TBD
		y		TBD	0.5877	TBD
	Blue	x		TBD	0.1584	TBD
		y		TBD	0.1696	TBD
	White	x		TBD	0.3268	TBD
		y		TBD	0.3690	TBD

Note 1: Definition of viewing angle range

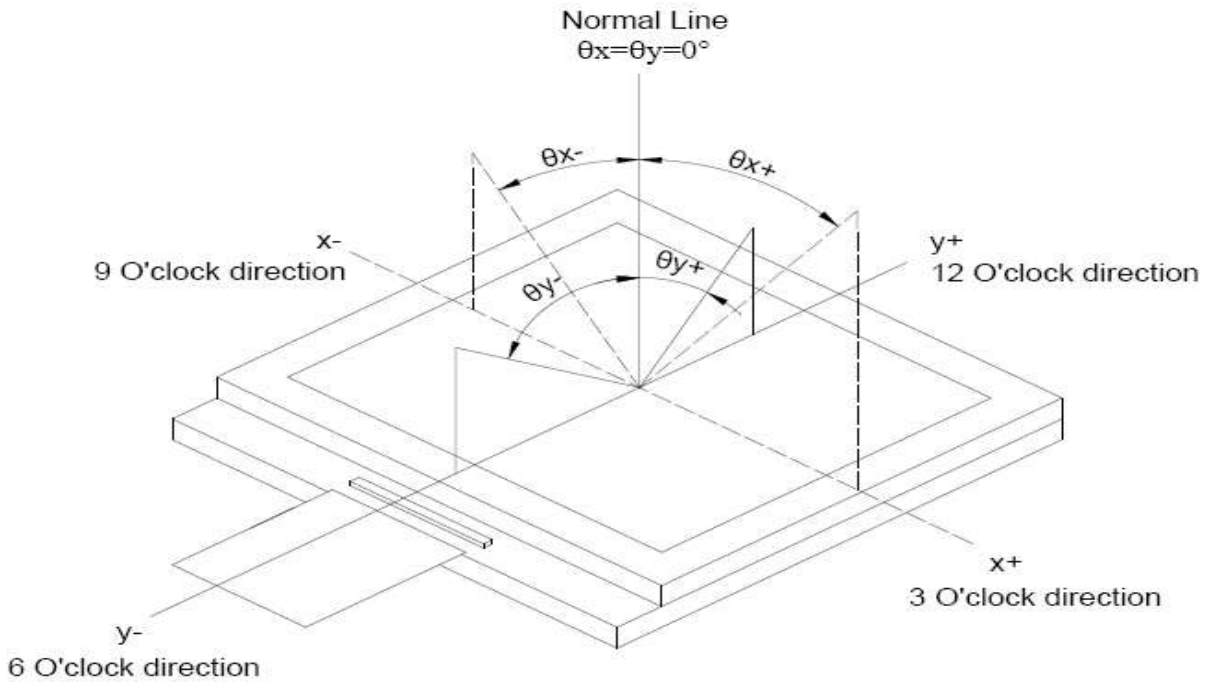

Note (2) Definition of Contrast Ratio(CR) :
measured at the center point of panel

$$\text{Contrast ratio (CR)} = \frac{\text{Photo detector output when LCD is at "White" state}}{\text{Photo detector output when LCD is at "Black" state}}$$

Note (3) Definition of Response Time : Sum of T_R and T_F

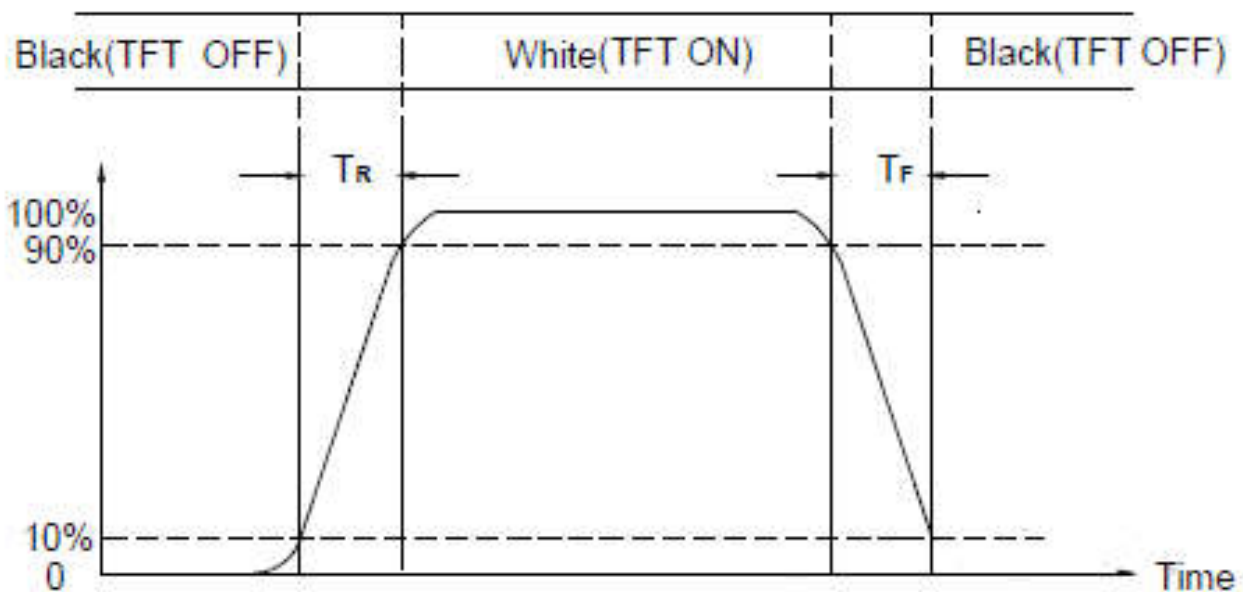

8. Interface Pin Assignment:

8-1 LCM FPC Interface

No.	Symbol	I/O	Function	Remark
1	VCOM	P	Common Voltage	
2	VDD	P	Power Voltage.	
3	VDD	P	Power Voltage.	
4	NC	---	Internal testing pin. (No Connection)	
5	NC	---	Internal testing pin. (No Connection)	
6	NC	---	Internal testing pin. (No Connection)	
7	GND	P	Ground	
8	RXIN0-	I	-LVDS differential data input	R0-R5, G0
9	RXIN0+	I	+LVDS differential data input	
10	GND	P	Ground	
11	RXIN1-	I	-LVDS differential data input	G1~G5, B0,B1
12	RXIN1+	I	+LVDS differential data input	
13	GND	P	Ground	
14	RXIN2-	I	-LVDS differential data input	B2-B5,HS,VS, DE
15	RXIN2+	I	+LVDS differential data input	
16	GND	P	Ground	
17	RXCLKIN-	I	-LVDS differential clock input	LVDS CLK
18	RXCLKIN+	I	+LVDS differential clock input	
19	GND	P	Ground	
20	RXIN3-	I	-LVDS differential data input	R6,R7,G6,G7, B6,B7
21	RXIN3+	I	+LVDS differential data input	
22	GND	P	Ground	
23	NC	---	No Connection	
24	NC	---	No Connection	
25	GND	P	Ground	
26	NC	---	No Connection	
27	LED_PWM	O	CABC controller signal output for backlight	Note2
28	NC	---	No Connection	
29	NC	---	No Connection	
30	GND	P	Ground	

No.	Symbol	I/O	Function	Remark
31	LED-	P	LED Cathode	
32	LED-	P	LED Cathode	
33	NC	---	No Connection	
34	NC	---	No Connection	
35	NC	---	Internal testing pin. (No Connection)	
36	NC	---	No Connection	
37	CABC_EN	I	CABC Enable Input	Note1
38	NC	---	No Connection	
39	LED+	P	Power Supply for LED Driver	
40	LED+	P	Power Supply for LED Driver	

I: input, O: output, P: Power

Note1: The setting of CABC function are as follows

Pin	Enable	Disable
CABC_EN	High Voltage	Low Voltage or open

Note2: LED_PWM is used to adjust backlight brightness.

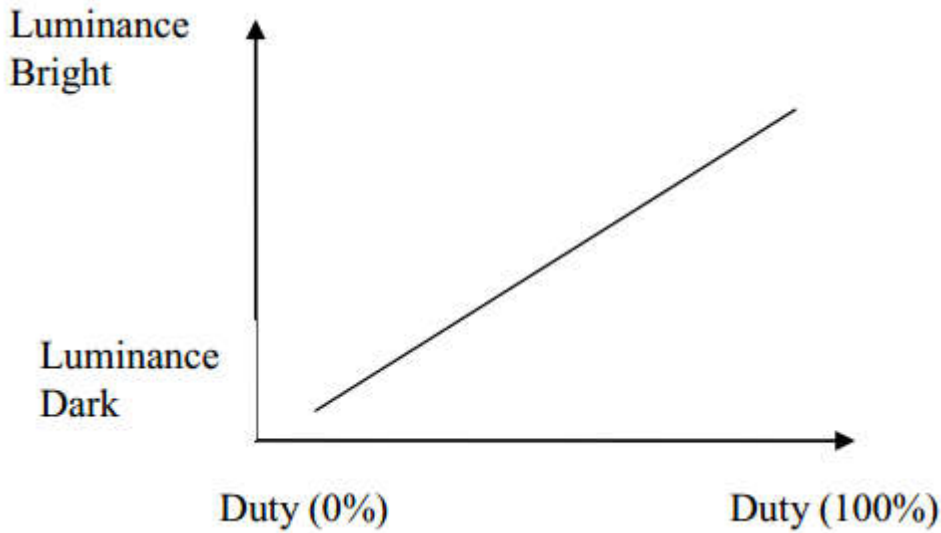

9. Backlight:

1. Standard Lamp Styles (Edge Lighting Type):
The LED chips are distributed over the edge light area of the illumination unit, which gives the less power consumption:
2. The Main Advantages of the LED Backlight are as following:
 - 2.1 The brightness of the backlight can simply be adjusted.
By a resistor or a potentiometer.

3. Data About LED Backlight:

(Ta=25°C)

PARAMETER	Sym.	Min.	Typ.	Max.	Unit	Test Condition	Note
Supply Current	I	-	140	-	mA	-	-
Voltage of the Backlight	V _{BL}	18.9	21.0	24.5	V	If=140mA	-
Luminous Intensity for LCM	IV	600	800	-	cd/m ²		2
Uniformity for LCM	-	70	-	-	%		3
LED Life Time	-	50000	-	-	Hr		4
Color	White						

NOTE:

1. Backlight Only
2. Average Luminous Intensity of P1-P13
3. Uniformity = Min/Max * 100%
4. LED life time defined as follows: The final brightness is at 50% of original brightness

Measured Method: (X*Y: Light Area)

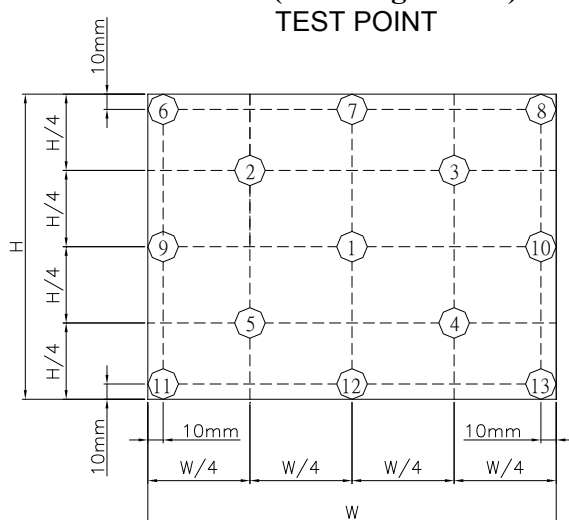

Internal Circuit Diagram

CIRCUIT DIAGRAM
B/L Electrical Circuit

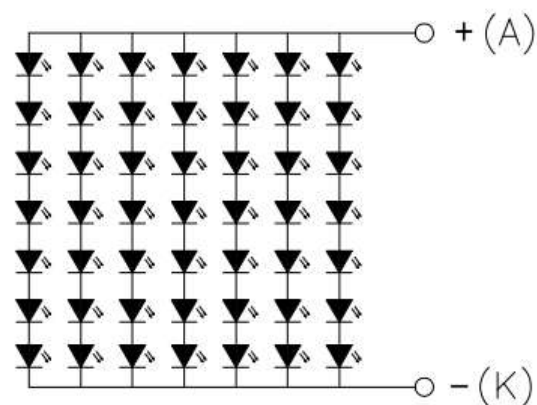

(Effective spatial Distribution)

Using aperture of 1°, distance 50cm.

10. Standard Specification for Reliability:

10-1. Standard Specifications for Reliability of LCD Module

No	Item	Description
01	High temperature operation	The sample should be allowed to stand at 70°C for 120 hours under driving condition and then returning it to normal temperature condition, and allowing it stand for 2 hours.
02	Low temperature operation	The sample should be allowed to stand at -20°C for 120 hours under driving condition and then returning it to normal temperature condition, and allowing it stand for 2 hours.
03	High temperature storage	The sample should be allowed to stand at 80°C for 240 hours under no-load condition, and then returning it to normal temperature condition, and allowing it stand for 2 hours.
04	Low temperature storage	The sample should be allowed to stand at -30°C for 240 hours under no-load condition, then returning it to normal temperature condition, and allowing it stand for 2 hours.
05	Moisture storage	The sample should be allowed to stand at 60°C, 90%RH MAX for 240 hours under no-load condition, then taking it out and drying it at normal temperature for 2 hours.
06	Thermal shock storage	The sample should be allowed to stand the following 10 cycles : -30°C for 30 minutes → normal temperature for 5 minutes → +80°C for 30 minutes → normal temperature for 5 minutes, as one cycle.
07	Packing vibration	Frequency range : 10Hz ~ 55Hz Amplitude of vibration : 1.5mm Sweep time: 12 min X,Y,Z 2 hours for each direction.
08	Packing drop test	According to ISTA 1A 2001.
09	Electrical Static Discharge	Air: ±6KV 150pF/330Ω 5 times
		Contact: ±4KV 150pF/330Ω 5 time

*Sample size for each test item is 3~5pcs

10 - 2. Testing Conditions and Inspection Criteria

For the final test the testing sample must be stored at room temperature for 24 hours, after the tests listed in Table 12.2, Standard specifications for Reliability have been executed in order to ensure stability.

No	Item	Test Model	In section Criteria
01	Current Consumption	Refer To Specification	The current consumption should conform to the product specification.
02	Contrast	Refer To Specification	After the tests have been executed, the contrast must be larger than half of its initial value prior to the tests.
03	Appearance	Visual inspection	Defect free.

10- 3. MTBF

MTBF	Functions, performance, appearance, etc. shall be free from remarkable deterioration within 50,000 hours under ordinary operating and storage conditions room temperature (25±5°C), normal humidity (50±10% RH), and in area not exposed to direct sun light.
------	---

11. Specification of Quality Assurance:

11-1. Purpose

This standard for Quality Assurance should affirm the quality of LCD module products to supply to purchaser by YEEBO CORPORATION (Supplier).

11-2. Standard for Quality Test

a. Inspection:

Before delivering, the supplier should take the following tests, and affirm the quality of product.

b. Electro-Optical Characteristics:

According to the individual specification to test the product.

c. Test of Appearance Characteristics:

According to the individual specification to test the product.

d. Test of Reliability Characteristics:

According to the definition of reliability on the specification for testing products.

e. Delivery Test:

Before delivering, the supplier should take the delivery test.

(i) Test method: According to **ISO2859-1**.General Inspection Level II take a single time.

(ii) The defects classify of AQL as following:

Major defect: AQL = 0.65%

Minor defect: AQL = 2.5%

Total defects: AQL = 2.5%

11-3. Non- conforming Analysis & Deal With Manners

a. Non- conforming Analysis:

(i) Purchaser should supply the detail data of non- conforming sample and the non-conforming.

(ii) After accepting the detail data from purchaser, the analysis of non- conforming should be finished in two weeks.

(iii) If supplier can not finish analysis on time, must announce purchaser before 3 days.

b. Disposition of non- conforming:

(i) If find any product defect of supplier during assembly time, supplier must change the good product for every defect after recognition.

(ii) Both supplier and customer should analyze the reason and discuss the disposition of non- conforming when the reason of nonconforming is not sure.

11-4. Agreement items

Both sides should discuss together when the following problems happen.

a. There is any problem of standard of quality assurance, and both sides should think that must be modified.

b. There is any argument item which does not record in the standard of quality assurance.

c. Any other special problem.

11-5. Standard of The Product Appearance Test

a. Manner of appearance test:

- (i) The test must be under 20W × 2 or 40W fluorescent light, and the distance of view must be at 30±5cm.
- (ii) When test the model of transmissive product must add the reflective plate.
- (iii) The test direction is base on around 10° of vertical line.
- (iiii) Temperature: 25±5°C Humidity: 60±10%RH

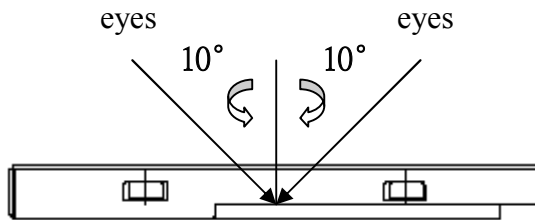

(iv) Definition of area:

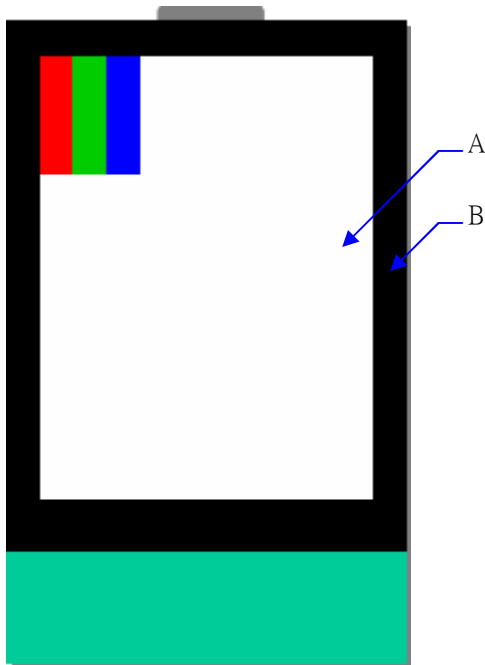

- A. Area: Viewing area.
- B. Area: Out of viewing area.
(Outside viewing area)

b. Basic principle:

- (i) It will accord to the AQL when the standard can not be described.
- (ii) The sample of the lowest acceptable quality level must be discussed by both supplier and customer when any dispute happened.
- (iii) Must add new item on time when it is necessary.

c. Standard of inspection: (Unit: mm)

11-6. Inspection specification

Defect out of viewing area can be neglected.

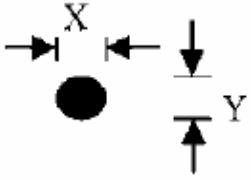
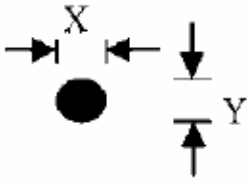
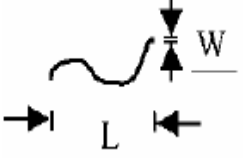
NO	Item	Criterion	AQL													
01	Electrical Testing	1.1 Missing vertical, horizontal segment, segment contrast defect. 1.2 Missing character, dot or icon. 1.3 Display malfunction. 1.4 No function or no display. 1.5 Current consumption exceeds product specifications. 1.6 LCD viewing angle defect. 1.7 Mixed product types. 1.8 Flicker	0.65													
02	Black or White spots or Bright spots or Color spots on LCD (Display only)	2.1 Dot dimension as below drawing: $\Phi = (X+Y) / 2$  <table border="1" data-bbox="821 772 1353 936"> <thead> <tr> <th>Size(mm)</th> <th>Acceptable Q'ty</th> </tr> </thead> <tbody> <tr> <td>$\Phi \leq 0.20$</td> <td>Accept no dense</td> </tr> <tr> <td>$0.20 < \Phi \leq 0.60$</td> <td>5</td> </tr> <tr> <td>$0.60 < \Phi$</td> <td>0</td> </tr> </tbody> </table> 2.2 Not visible through 5% ND filter * Densely spaced: No more than two spots within 3mm.	Size(mm)	Acceptable Q'ty	$\Phi \leq 0.20$	Accept no dense	$0.20 < \Phi \leq 0.60$	5	$0.60 < \Phi$	0	2.5					
Size(mm)	Acceptable Q'ty															
$\Phi \leq 0.20$	Accept no dense															
$0.20 < \Phi \leq 0.60$	5															
$0.60 < \Phi$	0															
03	LCD and Touch Panel black spots, white spots, contamination (non – display)	3.1 Round type: As following drawing $\Phi = (X+Y) / 2$  <table border="1" data-bbox="821 1198 1353 1361"> <thead> <tr> <th>Size(mm)</th> <th>Acceptable Q'ty</th> </tr> </thead> <tbody> <tr> <td>$\Phi \leq 0.20$</td> <td>Accept no dense</td> </tr> <tr> <td>$0.20 < \Phi \leq 0.60$</td> <td>5</td> </tr> <tr> <td>$0.60 < \Phi$</td> <td>0</td> </tr> </tbody> </table> * Densely spaced: No more than two spots within 3mm.	Size(mm)	Acceptable Q'ty	$\Phi \leq 0.20$	Accept no dense	$0.20 < \Phi \leq 0.60$	5	$0.60 < \Phi$	0	2.5					
		Size(mm)	Acceptable Q'ty													
$\Phi \leq 0.20$	Accept no dense															
$0.20 < \Phi \leq 0.60$	5															
$0.60 < \Phi$	0															
3.2 Line type: (As following drawing)  <table border="1" data-bbox="726 1556 1353 1899"> <thead> <tr> <th>Length(mm)</th> <th>Width(mm)</th> <th>Acceptable Q'ty</th> </tr> </thead> <tbody> <tr> <td>$L \leq 10$</td> <td>$W \leq 0.1$</td> <td>Accept no dense</td> </tr> <tr> <td>$L \leq 10.0$</td> <td>$0.1 < W \leq 0.25$</td> <td>4</td> </tr> <tr> <td>$L > 10$</td> <td>----</td> <td>Rejection</td> </tr> <tr> <td>----</td> <td>$0.25 < W$</td> <td>Rejection</td> </tr> </tbody> </table> * Densely spaced: No more than two lines within 3mm.	Length(mm)	Width(mm)	Acceptable Q'ty	$L \leq 10$	$W \leq 0.1$	Accept no dense	$L \leq 10.0$	$0.1 < W \leq 0.25$	4	$L > 10$	----	Rejection	----	$0.25 < W$	Rejection	2.5
Length(mm)	Width(mm)	Acceptable Q'ty														
$L \leq 10$	$W \leq 0.1$	Accept no dense														
$L \leq 10.0$	$0.1 < W \leq 0.25$	4														
$L > 10$	----	Rejection														
----	$0.25 < W$	Rejection														

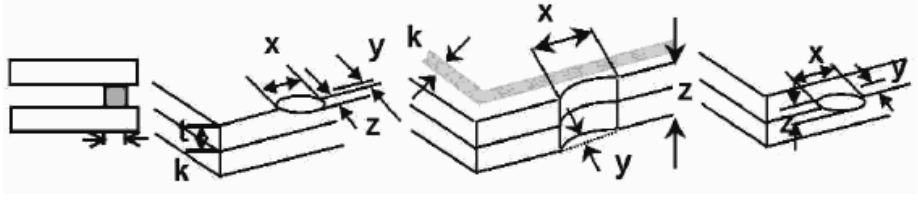
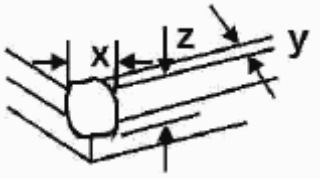
NO	Item	Criterion	AQL																		
04	Polarizer bubbles	<p>If bubbles are visible, judge using black spot specifications, not easy to find, must check in specify direction</p> <table border="1"> <thead> <tr> <th>Size Φ(mm)</th> <th>Acceptable Q'ty</th> </tr> </thead> <tbody> <tr> <td>$\Phi \leq 0.20$</td> <td>Accept no dense</td> </tr> <tr> <td>$0.20 < \Phi \leq 0.60$</td> <td>4</td> </tr> <tr> <td>$0.60 < \Phi \leq 1.00$</td> <td>3</td> </tr> <tr> <td>$1.00 < \Phi$</td> <td>0</td> </tr> <tr> <td>Total Q'ty</td> <td>4</td> </tr> </tbody> </table>	Size Φ (mm)	Acceptable Q'ty	$\Phi \leq 0.20$	Accept no dense	$0.20 < \Phi \leq 0.60$	4	$0.60 < \Phi \leq 1.00$	3	$1.00 < \Phi$	0	Total Q'ty	4	2.5						
Size Φ (mm)	Acceptable Q'ty																				
$\Phi \leq 0.20$	Accept no dense																				
$0.20 < \Phi \leq 0.60$	4																				
$0.60 < \Phi \leq 1.00$	3																				
$1.00 < \Phi$	0																				
Total Q'ty	4																				
05	Scratches	Follow NO.3 -2 Line Type.																			
06	Mura	Not visible through 5% ND filter in 50% gray.	2.5																		
07	Chipped glass	<p>Symbols: x: Chip length y: Chip width z: Chip thickness k: Seal width t: Glass thickness a: LCD side length L: Electrode pad length</p> <p>7.1 General glass chip: 7.1.1 Chip on panel surface and crack between panels:</p>  <table border="1"> <thead> <tr> <th>z: Chip thickness</th> <th>y: Chip width</th> <th>x: Chip length</th> </tr> </thead> <tbody> <tr> <td>$Z \leq 1/2t$</td> <td>Not over viewing area</td> <td>$x \leq 1/8a$</td> </tr> <tr> <td>$1/2t < z \leq 2t$</td> <td>Not exceed 1/3k</td> <td>$x \leq 1/8a$</td> </tr> </tbody> </table> <p>⊙ Unit: mm ⊙ If there are 2 or more chips, x is the total length of each chip</p> <p>7.1.2 Corner crack:</p>  <table border="1"> <thead> <tr> <th>z: Chip thickness</th> <th>y: Chip width</th> <th>x: Chip length</th> </tr> </thead> <tbody> <tr> <td>$Z \leq 1/2t$</td> <td>Not over viewing area</td> <td>$x \leq 1/8a$</td> </tr> <tr> <td>$1/2t < z \leq 2t$</td> <td>Not exceed 1/3k</td> <td>$x \leq 1/8a$</td> </tr> </tbody> </table> <p>⊙ Unit: mm ⊙ If there are 2 or more chips, x is the total length of each chip</p>	z: Chip thickness	y: Chip width	x: Chip length	$Z \leq 1/2t$	Not over viewing area	$x \leq 1/8a$	$1/2t < z \leq 2t$	Not exceed 1/3k	$x \leq 1/8a$	z: Chip thickness	y: Chip width	x: Chip length	$Z \leq 1/2t$	Not over viewing area	$x \leq 1/8a$	$1/2t < z \leq 2t$	Not exceed 1/3k	$x \leq 1/8a$	2.5
z: Chip thickness	y: Chip width	x: Chip length																			
$Z \leq 1/2t$	Not over viewing area	$x \leq 1/8a$																			
$1/2t < z \leq 2t$	Not exceed 1/3k	$x \leq 1/8a$																			
z: Chip thickness	y: Chip width	x: Chip length																			
$Z \leq 1/2t$	Not over viewing area	$x \leq 1/8a$																			
$1/2t < z \leq 2t$	Not exceed 1/3k	$x \leq 1/8a$																			

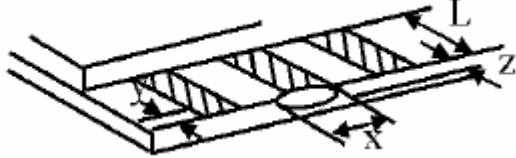
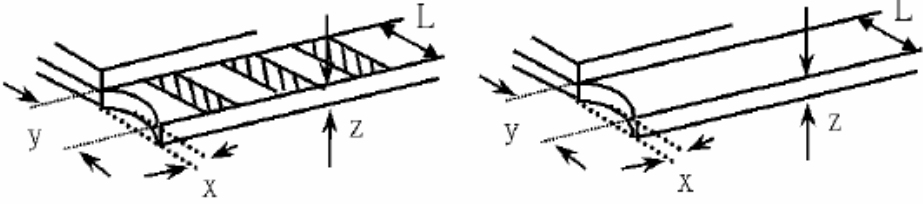
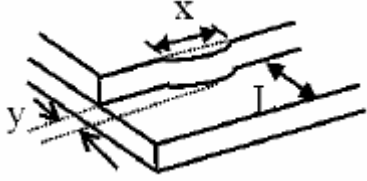
NO	Item	Criterion	AQL																
08	Glass crack	<p>Symbols: x: Chip length y: Chip width z: Chip thickness k: Seal width t: Glass thickness a: LCD side length L: Electrode pad length</p> <p>8.1 Protrusion over terminal: 8.1.1 Chip on electrode pad:</p>  <table border="1" data-bbox="545 685 1235 842"> <tr> <td>y: Chip width</td> <td>x: Chip length</td> <td>z: Chip thickness</td> </tr> <tr> <td>$y \leq 0.5\text{mm}$</td> <td>$x \leq 1/8a$</td> <td>$0 < z \leq t$</td> </tr> </table> <p>8.1.2 Non-conductive portion:</p>  <table border="1" data-bbox="545 1205 1235 1361"> <tr> <td>y: Chip width</td> <td>x: Chip length</td> <td>z: Chip thickness</td> </tr> <tr> <td>$y \leq L$</td> <td>$x \leq 1/8a$</td> <td>$0 < z \leq t$</td> </tr> </table> <p>⊙ If there chipped area touches the ITO terminal, over 2/3 of the ITO must remain and be inspected according to electrode terminal specifications. ⊙ If the product will be heat sealed by the customer, the alignment mark must not be damaged.</p> <p>8.1.3 Substrate protuberance and internal crack</p>  <table border="1" data-bbox="865 1675 1305 1832"> <tr> <td>y: width</td> <td>x: length</td> </tr> <tr> <td>$y \leq 1/3L$</td> <td>$X \leq a$</td> </tr> </table>	y: Chip width	x: Chip length	z: Chip thickness	$y \leq 0.5\text{mm}$	$x \leq 1/8a$	$0 < z \leq t$	y: Chip width	x: Chip length	z: Chip thickness	$y \leq L$	$x \leq 1/8a$	$0 < z \leq t$	y: width	x: length	$y \leq 1/3L$	$X \leq a$	2.5
y: Chip width	x: Chip length	z: Chip thickness																	
$y \leq 0.5\text{mm}$	$x \leq 1/8a$	$0 < z \leq t$																	
y: Chip width	x: Chip length	z: Chip thickness																	
$y \leq L$	$x \leq 1/8a$	$0 < z \leq t$																	
y: width	x: length																		
$y \leq 1/3L$	$X \leq a$																		

NO	Item	Criterion	AQL
09	Cracked glass	The LCD with extensive crack is not acceptable.	2.5
10	Backlight elements	10.1 Illumination source flickers when lit. 10.2 Spots or scratches that appear when lit must be judged. Using LCD spot, lines and contamination standards. 10.3 Backlight doesn't light or color is wrong.	2.5 2.5 0.65
11	Bezel	Bezel must comply with product specifications.	2.5
12	PCB、COB	12.1 COB seal may not have pinholes larger than 0.2mm or contamination. 12.2 COB seal surface may not have pinholes through to the IC. 12.3 The height of the COB should not exceed the height indicated in the assembly diagram. 12.4 There may not be more than 2mm of sealant outside the seal area on PCB. And there should be no more than three places. 12.5 Parts on PCB must be the same as on the production characteristic chart, There should be no wrong parts, missing parts or excess parts. 12.6 The jumper on the PCB should conform to the product characteristic chart.	2.5 2.5 2.5 2.5 0.65 0.65
13	FPC	13.1 FPC terminal damage \leq 1/2 FPC terminal width and can not affect the function , we judge accept. 13.2 FPC alignment hole damage \leq 1/2 alignment area and can not affect the function , we judge accept.	2.5 2.5
14	Soldering	14.1 No cold solder joints, missing solder connections, oxidation or icicle. 14.2 No short circuits in components on PCB or FPC.	2.5 0.65

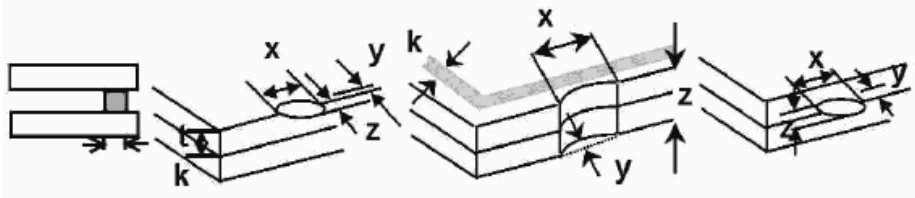
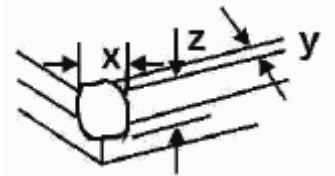
NO	Item	Criterion	AQL												
15	Touch Panel Chipped glass	<p>Symbols: x: Chip length y: Chip width z: Chip thickness k: Seal width t: Touch Panel Total thickness a: LCD side length L: Electrode pad length</p> <p>15.1 General glass chip: 15.1.1 Chip on panel surface and crack between panels:</p>  <table border="1" data-bbox="411 801 1233 1019"> <tr> <td>z: Chip thickness</td> <td>y: Chip width</td> <td>x: Chip length</td> </tr> <tr> <td>$Z \leq t$</td> <td>$\leq 1/2 k$ and not over viewing area</td> <td>$x \leq 1/8a$</td> </tr> </table> <p>⊙ Unit: mm ⊙ If there are 2 or more chips, x is the total length of each chip</p> <p>15.1.2 Corner crack:</p>  <table border="1" data-bbox="411 1400 1233 1617"> <tr> <td>z: Chip thickness</td> <td>y: Chip width</td> <td>x: Chip length</td> </tr> <tr> <td>$z \leq t$</td> <td>$\leq 1/2 k$ and not over viewing area</td> <td>$x \leq 1/8a$</td> </tr> </table> <p>⊙ Unit: mm ⊙ If there are 2 or more chips, x is the total length of each chip</p>	z: Chip thickness	y: Chip width	x: Chip length	$Z \leq t$	$\leq 1/2 k$ and not over viewing area	$x \leq 1/8a$	z: Chip thickness	y: Chip width	x: Chip length	$z \leq t$	$\leq 1/2 k$ and not over viewing area	$x \leq 1/8a$	2.5
z: Chip thickness	y: Chip width	x: Chip length													
$Z \leq t$	$\leq 1/2 k$ and not over viewing area	$x \leq 1/8a$													
z: Chip thickness	y: Chip width	x: Chip length													
$z \leq t$	$\leq 1/2 k$ and not over viewing area	$x \leq 1/8a$													

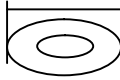
NO	Item	Criterion		AQL
16	Touch Panel(Fish eye)	SIZE(mm)	Acceptable Q'ty	2.5
		$L \leq 1.0$	Accept no dense	
		$L > 1.0\text{mm}$	0	
				
17	Touch Panel Newton ring	Newton ring dimension $\leq 1/2$ touch panel area and not affect font and line distortion($\leq 2.5\%$), it is acceptable.		2.5
18	Touch Panel Linearity	Less than 2.5% is acceptable.		2.5
19	LCD Ripple	Touch the touch panel, can not see the LCD ripple. Pen: R 1.0mm silicon rubber. Operation Force: 10~100g		2.5
20	General appearance	20.1 Pin type must match type in specification sheet.		0.65
		20.2 LCD pin loose or missing pins.		0.65
		20.3 Product packaging must the same as specified on packaging specification sheet.		0.65
		20.4 Product dimension and structure must conform to product specification sheet.		0.65

12. Handling Precaution:

12-1 Handling of LCM

- Don't give external shock.
- Don't apply excessive force on the surface.
- Liquid in LCD is hazardous substance. Must not lick and swallow. when the liquid is attach to your hand, skin, cloth etc. Wash it out thoroughly and immediately.
- Don't operate it above the absolute maximum rating.
- Don't disassemble the LCM.
- The operators should be grounded whenever he/she comes into contact with the module. Never touch any of the conductive parts such as the LSI pads, the copper leads on the FPC and the interface terminals with any parts of the human body.
- The modules should be kept in antistatic bags or other containers resistant to static for storage.
- The module is coated with a film to protect the display surface. Be care when peeling off this protective film since static electricity may be generated.

12-2 Storage

- Store in an ambient temperature of $25\pm 10^{\circ}\text{C}$, and in a relative humidity of $50\pm 10\%\text{RH}$. Don't expose to sunlight or fluorescent light.
- Storage in a clean environment, free from dust, active gas, and solvent.
- Store in anti-static electricity container.
- Store without any physical load.

12-3 Soldering

- Use only soldering irons with proper grounding and no leakage.
- Iron: No higher than $280\pm 10^{\circ}\text{C}$ and less than 3 sec during Hand soldering.
- Rewiring: no more than 2 times.

13. Guarantee:

Our products meet requirements of the environment.

YEEBO ROHS requirement is based on European Union Directive 2011/65/EU (ROHS) Requirements and Update.