



# SPECIFICATION FOR LCD MODULE

MODULE NO: YB-TG800480S21A-C-A0

Doc.Version:01

Customer Approval:

<input type="checkbox"/> Accept	<input type="checkbox"/> Reject
---------------------------------	---------------------------------

YEEBO	NAME	SIGNATURE	DATE
Prepare	Electronic Engineer		2014-7-3
Check	Mechanical Engineer		2014.7.3
Verify			2014.7.3
Approval			2014.7.3

APPROVAL FOR SPECIFICATIONS ONLY

APPROVAL FOR SPECIFICATIONS AND SAMPLE

WIMRD005-02-C





## **2. Table of Contents:**

<b>NO</b>	<b>CONTENTS</b>	<b>PAGE</b>
1	Revision History	1
2	Table of Contents	2
3	Module Numbering System	3
4	General Specification	4
5	LCM drawing	5
6	Electrical Characteristics	6
7	Optical Characteristics	10
8	Interface Pin Assignment	12
9	Block Diagram	14
10	Backlight	15
11	Standard Specification for Reliability	16
12	Specification of Quality Assurance	18
13	Handling Precaution	26
14	Guarantee	26



### 3. Module Numbering System:

(Example)

**YB - T G 240320 S 01 D -T - A0**

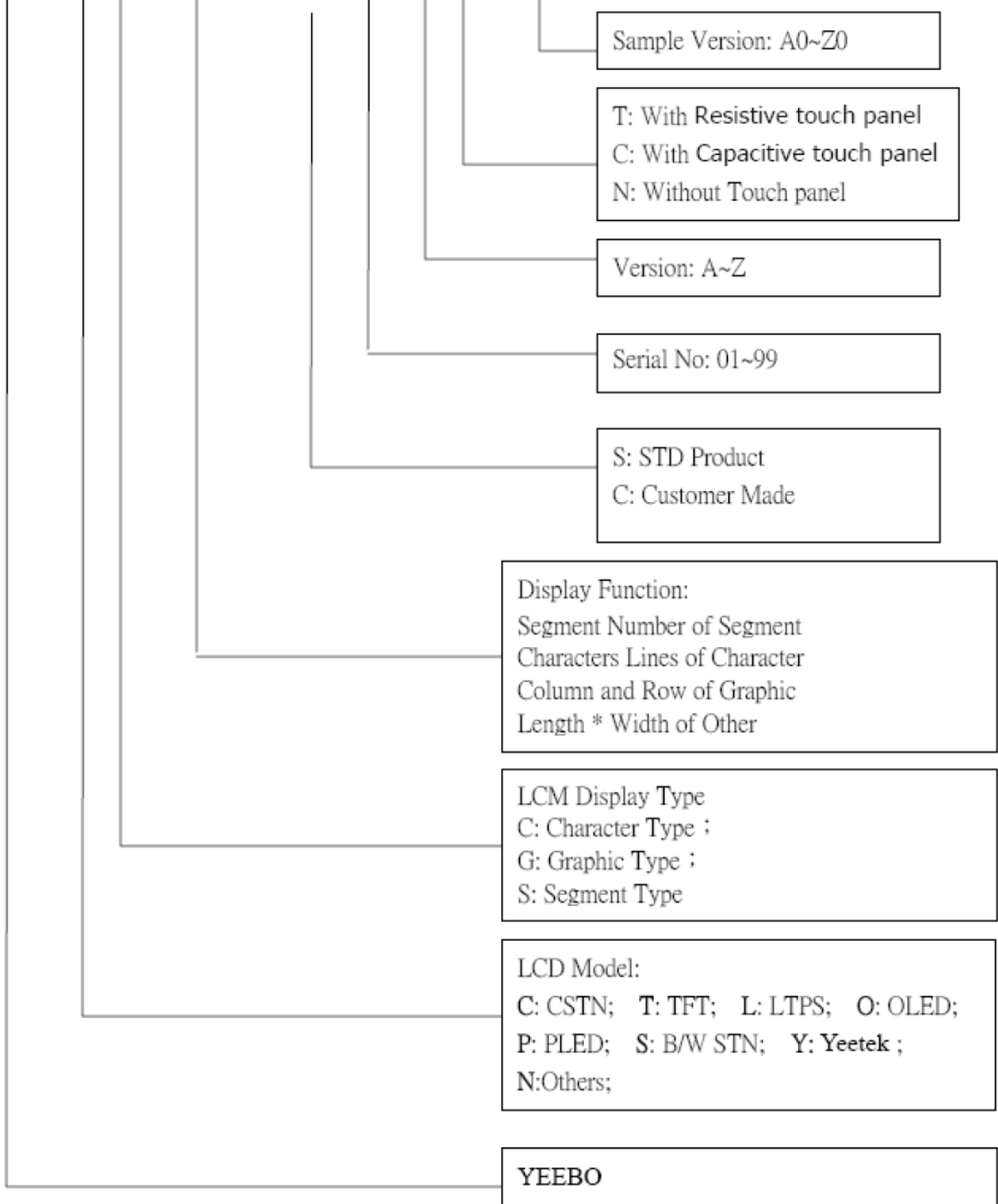



#### **4. General Specification:**

ITEM	CONTENTS
Module Size	190.0 (W) * 112.5 (H) * 4.6(T) mm
Module Size(With FPC)	235.85 (W) *171.32 (H) * 4.6(T) mm
Display Size (Diagonal)	7.0 inch
Display Format	800(RGB)* 480 Pixels
Active Area	153.6 (W) * 86.64 (H) mm
Dots Pitch	0.192 * 0.1805 mm
LCD Type	TFT (16.7M)/ Transmissive / Normal White
Touch panel Type	OLGS / PCTP
View Angle (Gray Inversion)	6:00 O'clock
The Best Viewing Direction	12:00 O'clock
Controller IC	NT39416Q & NT52001
CTP IC	ILI2303
Weight	161.0g



# 5. LCM drawing:

Count drawing & Spec. revision record during discussion with customer	
Rev:	Revision content description
#1	FIRST ISSUE
#2	Modify Spec Δ
Date	2014-04-18
Date	2014-07-03

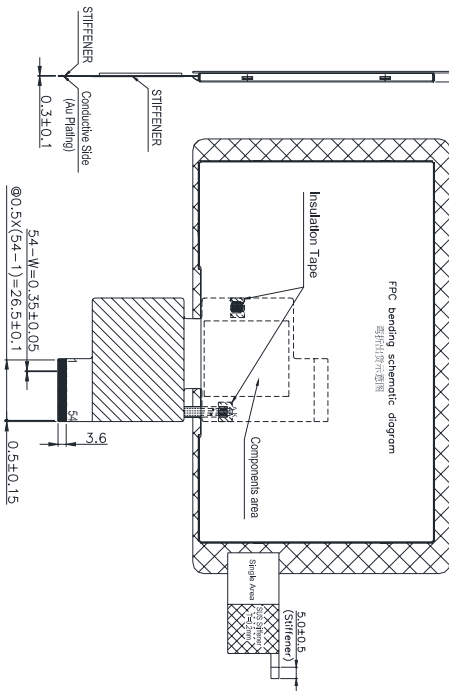
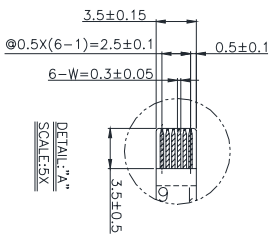
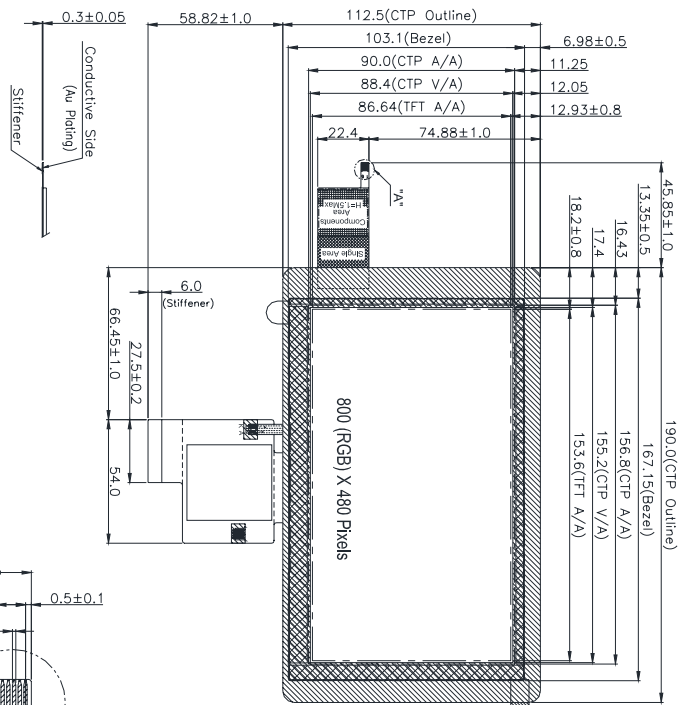

TOUCH PANEL	47	DITHB
PIN ASSIGNMENT	48	GND
No. Symbol	49	NC
1 VDD	50	NC
2 RESET	51	NC
3 INT	52	NC
4 SCL	53	A
5 SDA	54	A
6 GND	54	K

- Specification:**
1. Display mode: 7.0" TFT, Normal White/ Transmissive
  2. Color depth: 16.7M Colors
  3. Gray Scale Inversion Direction: 6:00 O'clock
  4. The Best Viewing Direction: 12:00 O'clock
  5. Storage temperature: -30°C to +80°C
  6. Drive IC: NT39416Q & NT52001
  7. Backlight: 18 CHIP WHITE LED/ LCM Luminance(with T/P): 220 cd/m<sup>2</sup> (TYP)/ V=9.6V(TYP)/ If=120mA
  8. ROHS compliant
  9. Glass Type: OLGs PCTP
  10. Channel NO.: 28(X) x 16(Y)
  11. Drive ICs: IL12303

		UNIT	SIZE	SCALE	DESIGNED	CHECKED	VERIFIED	APPROVED	FILE NAME
		mm	A4	N-T-S	連翊班				YB-TG800480S21A-C-A
MOD. Name		YB-TG800480S21A-C-A							
Sheet	1								
Of	1								



## 6. Electrical Characteristics

### 6-1 Absolute Maximum Ratings

(Ta=25°C VSS=0V)

TFT IC Parameter ( NT39416Q & NT52001)

Item	Symbol	Min.	Type	Max.	Unit	Remark
Power Supply voltage	DVDD	-0.3		5.0	Volt	
	AVDD	-0.3	-	15	Volt	
	VDDG	-0.3		42	Volt	
	VEEG	-20		-0.3	Volt	
	VDDG-VEEG	-0.3	-	40	Volt	DVDD =3.3V
Operating Temperature	Topr	-20	-	+70	°C	
Storage Temperature	Tstg	-30	-	+80	°C	

Touch panel controller IC ( ILI2303 )

Item	Symbol	Min.	Type	Max.	Unit	Remark
Power Supply voltage	VDD	-0.3		3.3	Volt	

Note: Absolute maximum rating is the limit value beyond which the IC maybe broken.

### 6-2 Operating Conditions

(Ta=25°C )

TFT IC Parameter (NT39416Q & NT52001)

Item	Symbol	Condition	Min.	Typ.	Max.	Unit
Power Supply voltage	DVDD	-	3.1	3.3	3.5	Volt
	AVDD	-	10.3	10.5	10.7	Volt
	VCOM	-	3.7	3.9	4.2	Volt
	VDDG		14.3	15.0	15.7	Volt
	VEEG	-	-7.7	-7.0	-6.3	Volt
Level Input Voltage (Digital signal)	VIH	-	0.7*DVDD	-	DVDD	Volt
	VIL	-	GND	-	0.3*DVDD	Volt
	VOH	-	DVDD-0.4	-	DVDD	Volt
	VOL	-	GND	-	GND+0.4	Volt
Power Supply Current for LCM	DVDD_IDD	DVDD=3.3V	-	70	105	mA
	AVDD_IDD	AVDD=10.5V	-	13.5	20.3	mA

Touch panel controller IC ( ILI2303 )

Item	Symbol	Condition	Min.	Typ.	Max.	Unit
Power Supply voltage	VDD	-	3.0	3.3	3.3	Volt

Note:GND=VSS=0V

## 6-3 Data Input Timing

### 6-3-1 TFT Data Input Timing (Reference to NT39416Q)

#### Vertical Input Timing

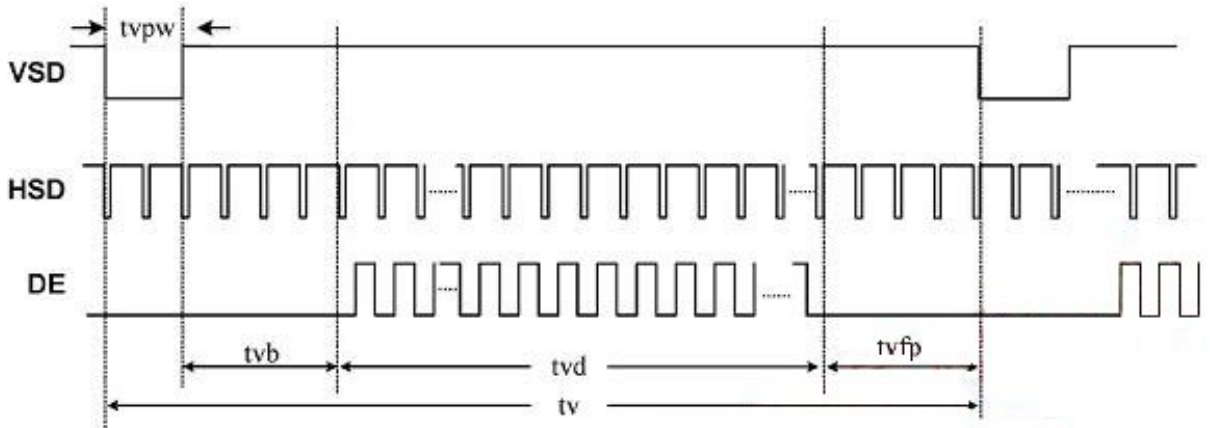

#### Horizontal Input Timing

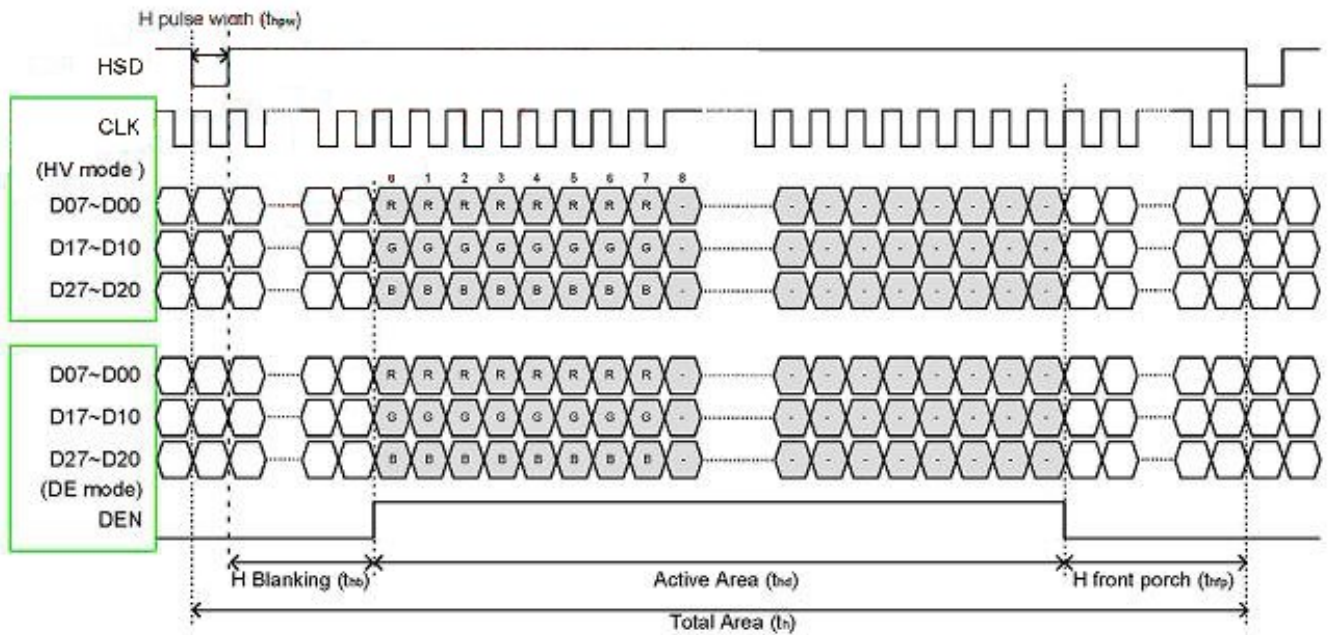





### Horizontal Input Timing Table

Parameter	Symbol	Value			Unit	Note
		Min.	Typ.	Max.		
DCLK frequency	fclk	20	33.3	50	MHz	DCLK(max) = 50MHz
Horizontal display area	thd	800			DCLK	
1 Horizontal Line	th	908	928	1088	DCLK	
HSD pulse width	thpw	1	48	87	DCLK	thb+thpw =88 DCLK is fixed.
HSD Back Porch (Blanking)	thb	87	40	1	DCLK	
HSD Front Porch	thfp	20	40	200	DCLK	

### Vertical Input Timing Table

Parameter	Symbol	Value			Unit	Note
		Min.	Typ.	Max.		
Vertical display area	tvd	480			H	
VSD period time	tv	517	525	712	H	
VSD pulse width	tvpw	1	1	3	H	Tvpw+tvb=32 H is fixed
VSD Back Porch (Blanking)	tvb	31	31	29	H	
VSD Front Porch	tvfp	5	13	200	H	

### 6-3-2 Touch panel controller IC Input Timing ( Reference to ILI2303 )

#### I<sup>2</sup>C interface

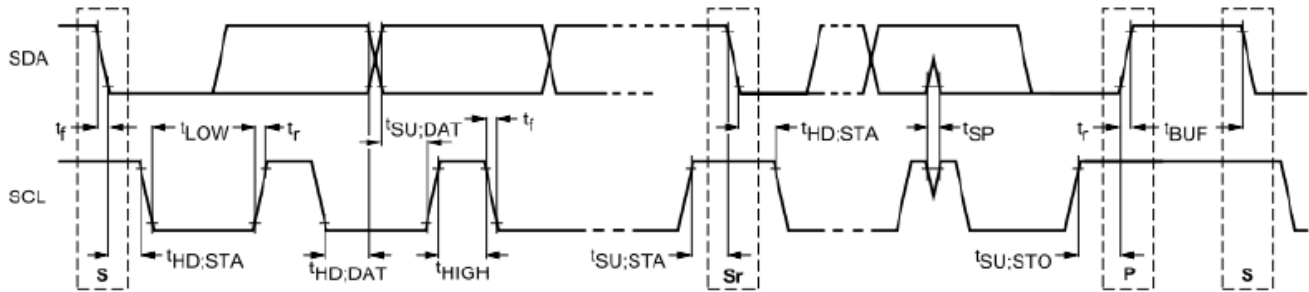

Symbol	Parameter	100KHz			400KHz		
		Min	Max	Unit	Min	Max	Unit
$f_{SCL}$	SCL clock frequency	0	100	kHz	0	400	kHz
$t_{HD:STA}$	Hold time (repeated) START condition. After this period, the first clock pulse is generated	4.0	–	$\mu s$	0.6	–	$\mu s$
$t_{LOW}$	LOW period of the SCL clock	4.7	–	$\mu s$	1.3	–	$\mu s$
$t_{HIGH}$	HIGH period of the SCL clock	4.0	–	$\mu s$	0.6	–	$\mu s$
$t_{SU:STA}$	Set-up time for a repeated START condition	4.7	–	$\mu s$	0.6	–	$\mu s$
$t_{HD:DAT}$	Data hold time	5.0	–	$\mu s$	0	0.9	$\mu s$
$t_{SU:DAT}$	Data set-up time	250	–	ns	100	–	ns
$t_r$	Rise time of both SDA and SCL signals	–	1000	ns	–	300	ns
$t_f$	Fall time of both SDA and SCL signals	–	300	ns	–	300	ns
$t_{SU:STO}$	Set-up time for STOP condition	4.0	–	$\mu s$	0.6	–	$\mu s$
$t_{BUF}$	Bus free time between a STOP and START condition	4.7	–	$\mu s$	1.3	–	$\mu s$



## 7. Optical Characteristics:

Item	Symbol	Conditions	Specifications			Unit	Note	
			Min	Typ	Max			
Transmittance	T(%)	-	-	5.0	-	-	-	
Contrast Ratio	CR	$\theta=0$ Normal Viewing angle	-	500	-		(1) (2)	
Response time	TR+TF	-	-	25	-	ms	(1) (3)	
Viewing angle	Hor.	$\Theta_{x+}$	CR $\geq 10$	60	70	-	deg.	-
		$\Theta_{x-}$		60	70	-		
	Ver.	$\Theta_{y+}$		40	50	-		
		$\Theta_{y-}$		50	60	-		

### Measuring Condition

1. Measuring surrounding: dark room
2. Ambient temperature:  $25 \pm 2^\circ\text{C}$
3. 30 min. Warm-up time.

### Color of CIE Coordinate:

Item	Symbol	Condition	Min.	Typ.	Max.	Brightness	
Chromaticity Coordinates (Transmissive)	Red	x	$\theta = \varphi = 0^\circ$ LED Backlight Color Degree X=0.30 Y=0.30 Brightness =5000 cd/m <sup>2</sup>	0.5959	0.5974	0.5993	55 cd/m <sup>2</sup>
		y		0.3551	0.3561	0.3577	
	Green	x		0.3223	0.3244	0.3256	180 cd/m <sup>2</sup>
		y		0.5676	0.5688	0.5702	
	Blue	x		0.1529	0.1537	0.1569	35 cd/m <sup>2</sup>
		y		0.0921	0.0945	0.0973	
	White	x		0.2964	0.3000	0.3038	250 cd/m <sup>2</sup>
		y		0.3198	0.3245	0.3295	

Note (1) Definition of Viewing Angle :

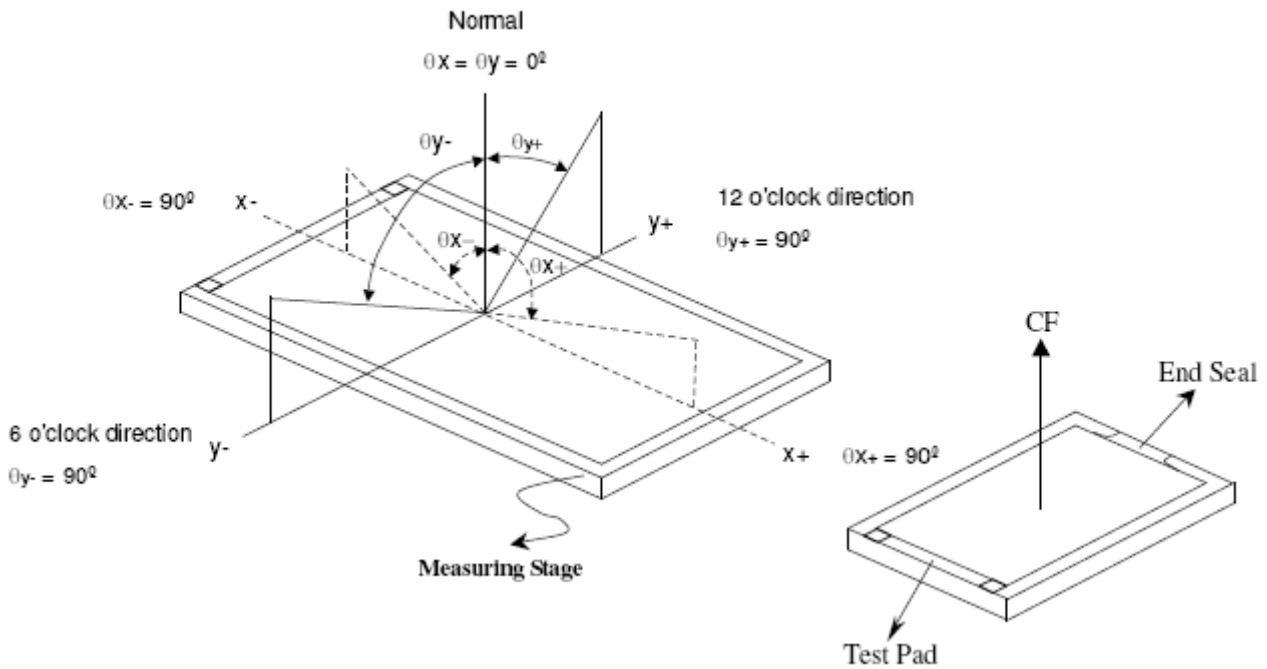

Note (2) Definition of Contrast Ratio(CR) :  
measured at the center point of panel

$$\text{Contrast ratio (CR)} = \frac{\text{Photo detector output when LCD is at "White" state}}{\text{Photo detector output when LCD is at "Black" state}}$$

Note (3) Definition of Response Time : Sum of TR and TF

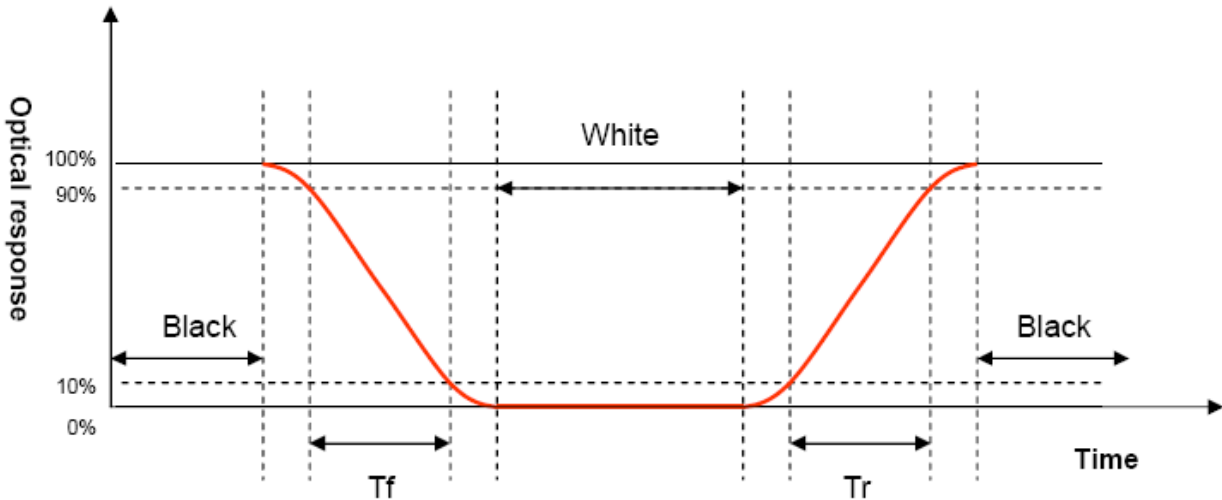



## 8. Interface Pin Assignment:

### 8-1 LCM FPC Interface

No.	Symbol	Function
1	NC	No Connection
2	NC	No Connection
3	NC	No Connection
4	NC	No Connection
5	GND	Power ground
6	VCOM	Common voltage input.
7	DVDD	Digital Power input.
8	MODE	DE/SYNC mode select. Normally pull high H:DE mode. L:HSD/VSD mode
9	DE	Data Enable signal
10	VS	Vertical sync input. Negative polarity
11	HS	Horizontal sync input. Negative polarity
12~19	B7~B0	Blue Data Input
20~27	G7~G0	Green Data Input
28~35	R7~R0	Red Data Input
36	GND	Power ground
37	DCLK	Data clock Input
38	GND	Power ground
39	SHLR	Left or Right Display Control
40	UPDN	Up / Down Display Control
41	VDDG	Positive Power for TFT. (VGH)
42	VEEG	Negative Power for TFT.(VGL)
43	AVDD	Analog Power input.
44	RSTB	Global reset pin. Active low to enter reset state. Suggest to connecting with an RC reset circuit for stability. Normally pull high. (R=10K , C=1μF)
45	NC	Not connect
46	VCOM	Common Voltage input.
47	DITHB	Dithering setting, Normally pull high. DITH="H" 6bit resolution(last 2 bit of input data truncated)
48	GND	Power ground
49	NC	Not connect



50	NC	No Connection
51	NC	No Connection
52	NC	No Connection
53	A	Black Light+
54	K	Black Light -

## 8-2 CTP Interface Pin

No.	Symbol	Function
1	VDD	Analog power supply.
2	RESET	RESET.
3	INT	External interrupt pin to host.
4	SCL	Serial clock pin for I2C interface.
5	SDA	Serial data pin for I2C interface.
6	GND	Ground.

Note: I2C interface

## 9. Block Diagram:

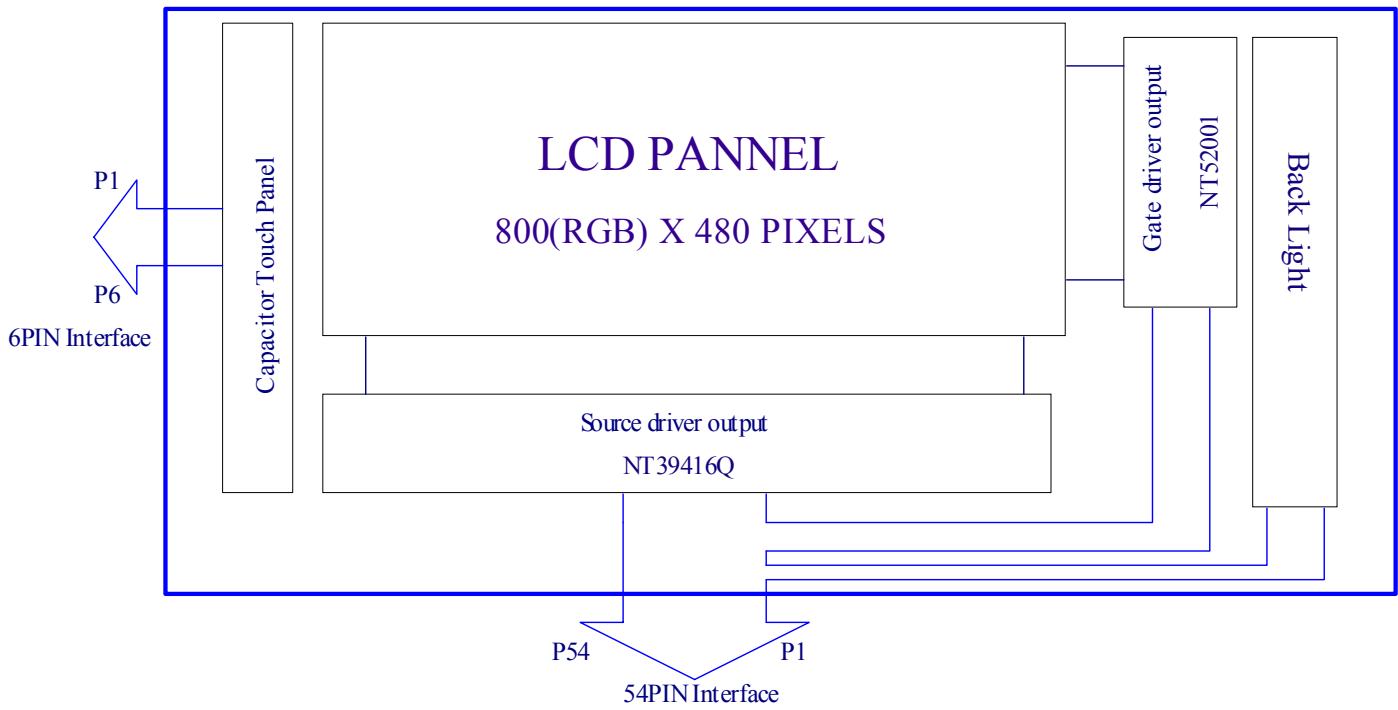

## 10. Backlight:

### 1. Standard Lamp Styles (Edge Lighting Type):

The LED chips are distributed over the edge light area of the illumination unit, which gives the less power consumption:

### 2. The Main Advantages of the LED Backlight are as following:

2.1 The brightness of the backlight can simply be adjusted.

By a resistor or a potentiometer.

### 3. Data About LED Backlight:

PARAMETER	Sym.	Min.	Typ.	Max.	Unit	Test Condition	Note
Supply Current	I	120			mA	V=9.6V	
Supply Voltage	V	-	9.6	-	V	If=120mA	
Reverse Voltage	VR	-	-	5.0	V	-	
Luminous Intensity for LCM	IV	150	220	-	Cd/m <sup>2</sup>	If=120mA	2
Uniformity for LCM	-	70	-	-	%		3
Life Time	-	20000	-	-	Hr.		4
Color	White						

NOTE:

1. Backlight Only

2. Average Luminous Intensity of P1-P13

3. Uniformity = Min/Max \* 100%

4. LED life time defined as follow: the final brightness is at 70% of original brightness

### Measured Method: (X\*Y: Light Area)

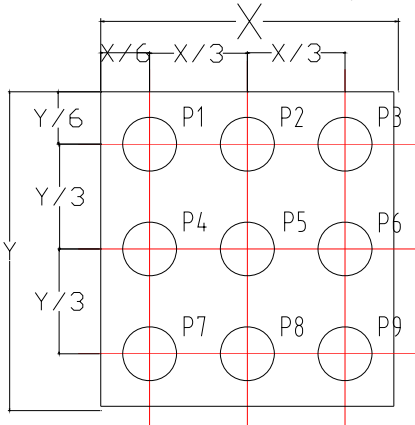

### Internal Circuit Diagram

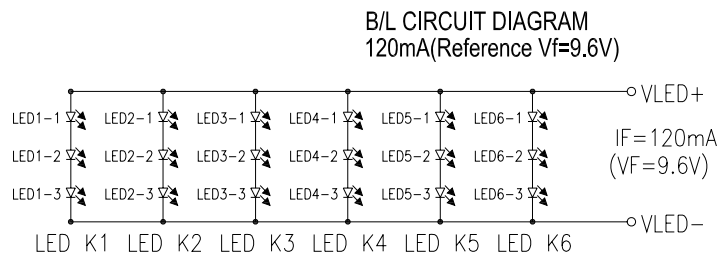



## **11. Standard Specification for Reliability:**

### 11-1. Standard Specifications for Reliability of LCD Module

No	Item	Description
01	High temperature operation	The sample should be allowed to stand at 70°C for 120 hours under driving condition and then returning it to normal temperature condition, and allowing it stand for 2 hours.
02	Low temperature operation	The sample should be allowed to stand at -20°C for 120 hours under driving condition and then returning it to normal temperature condition, and allowing it stand for 2 hours.
03	High temperature storage	The sample should be allowed to stand at 80°C for 240 hours under no-load condition, and then returning it to normal temperature condition, and allowing it stand for 2 hours.
04	Low temperature storage	The sample should be allowed to stand at -30°C for 240 hours under no-load condition, then returning it to normal temperature condition, and allowing it stand for 2 hours.
05	Moisture storage	The sample should be allowed to stand at 60°C, 90%RH MAX for 240 hours under no-load condition, then taking it out and drying it at normal temperature for 2 hours.
06	Thermal shock storage	The sample should be allowed to stand the following 10 cycles : -30°C for 30 minutes → normal temperature for 5 minutes → +80°C for 30 minutes → normal temperature for 5 minutes, as one cycle.
07	Packing vibration	Frequency range : 10Hz ~ 55Hz Amplitude of vibration : 1.5mm      Sweep time: 12 min X,Y,Z 2 hours for each direction.
08	Packing drop test	According to ISTA 1A 2001.
09	Electrical Static Discharge	Air: ±6KV 150pF/330Ω 5 times
		Contact: ±4KV 150pF/330Ω 5 time



### 11 - 2. Testing Conditions and Inspection Criteria

For the final test the testing sample must be stored at room temperature for 24 hours, after the tests listed in Table 11-1, Standard specifications for Reliability have been executed in order to ensure stability.

No	Item	Test Model	In section Criteria
01	Current Consumption	Refer To Specification	The current consumption should conform to the product specification.
02	Contrast	Refer To Specification	After the tests have been executed, the contrast must be larger than half of its initial value prior to the tests.
03	Appearance	Visual inspection	Defect free.

### 11- 3. MTBF

MTBF	Functions, performance, appearance, etc. shall be free from remarkable deterioration within 50,000 hours under ordinary operating and storage conditions room temperature ( $25\pm 5^{\circ}\text{C}$ ), normal humidity ( $50\pm 10\%$ RH), and in area not exposed to direct sun light.
------	---



## **12. Specification of Quality Assurance:**

### 12-1. Purpose

This standard for Quality Assurance should affirm the quality of LCD module products to supply to purchaser by YEEBO CORPORATION (Supplier).

### 12-2. Standard for Quality Test

#### a. Inspection:

Before delivering, the supplier should take the following tests, and affirm the quality of product.

#### b. Electro-Optical Characteristics:

According to the individual specification to test the product.

#### c. Test of Appearance Characteristics:

According to the individual specification to test the product.

#### d. Test of Reliability Characteristics:

According to the definition of reliability on the specification for testing products.

#### e. Delivery Test:

Before delivering, the supplier should take the delivery test.

(i) Test method: According to MIL-STD105E.General Inspection Level II take a single time.

(ii) The defects classify of AQL as following:

Major defect: AQL = 0.65%

Minor defect: AQL = 2.5%

Total defects: AQL = 2.5%

### 12-3. Non- conforming Analysis & Deal With Manners

#### a. Non- conforming Analysis:

(i) Purchaser should supply the detail data of non- conforming sample and the non- conforming.

(ii) After accepting the detail data from purchaser, the analysis of non- conforming should be finished in two weeks.

(iii) If supplier can not finish analysis on time, must announce purchaser before 3 days.

#### b. Disposition of non- conforming:

(i) If find any product defect of supplier during assembly time, supplier must change the good product for every defect after recognition.

(ii) Both supplier and customer should analyze the reason and discuss the disposition of non- conforming when the reason of nonconforming is not sure.

### 12-4. Agreement items

Both sides should discuss together when the following problems happen.

a. There is any problem of standard of quality assurance, and both sides should think that must be modified.

b. There is any argument item which does not record in the standard of quality assurance.

c. Any other special problem.

12-5. Standard of The Product Appearance Test

a. Manner of appearance test:

- (i) The test must be under 20W × 2 or 40W fluorescent light, and the distance of view must be at 30±5cm.
- (ii) When test the model of transmissive product must add the reflective plate.
- (iii) The test direction is base on around 10° of vertical line.
- (iiii) Temperature: 25±5°C      Humidity: 60±10%RH

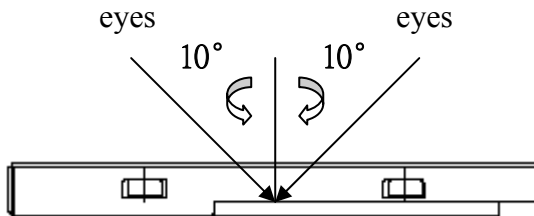

(iv) Definition of area:

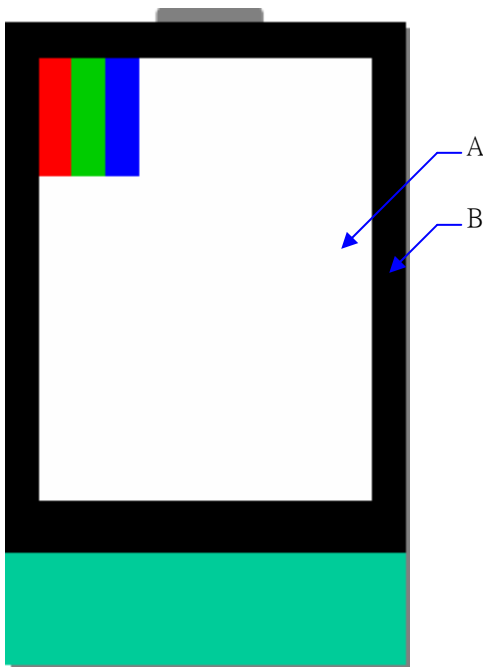

- A. Area: Viewing area.
- B. Area: Out of viewing area.  
(Outside viewing area)

b. Basic principle:

- (i) It will accord to the AQL when the standard can not be described.
- (ii) The sample of the lowest acceptable quality level must be discussed by both supplier and customer when any dispute happened.
- (iii) Must add new item on time when it is necessary.

c. Standard of inspection: (Unit: mm)

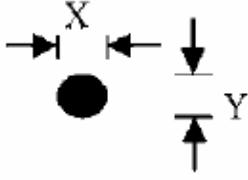
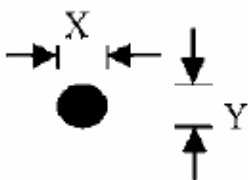
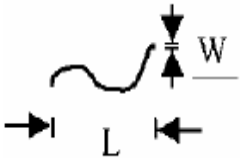
NO	Item	Criterion	AQL													
01	Electrical Testing	1.1 Missing vertical, horizontal segment, segment contrast defect. 1.2 Missing character, dot or icon. 1.3 Display malfunction. 1.4 No function or no display. 1.5 Current consumption exceeds product specifications. 1.6 LCD viewing angle defect. 1.7 Mixed product types. 1.8 Flicker	<b>0.65</b>													
02	Black or White spots or Bright spots or Color spots on LCD (Display only)	2.1 Dot dimension as below drawing: $\Phi = (X+Y) / 2$  <table border="1" data-bbox="817 728 1348 891"> <thead> <tr> <th>Size(mm)</th> <th>Acceptable Q'ty</th> </tr> </thead> <tbody> <tr> <td><math>\Phi \leq 0.20</math></td> <td>Accept no dense</td> </tr> <tr> <td><math>0.20 &lt; \Phi \leq 0.40</math></td> <td>5</td> </tr> <tr> <td><math>0.40 &lt; \Phi</math></td> <td>0</td> </tr> </tbody> </table> * Densely spaced: No more than two spots within 3mm	Size(mm)	Acceptable Q'ty	$\Phi \leq 0.20$	Accept no dense	$0.20 < \Phi \leq 0.40$	5	$0.40 < \Phi$	0	<b>2.5</b>					
Size(mm)	Acceptable Q'ty															
$\Phi \leq 0.20$	Accept no dense															
$0.20 < \Phi \leq 0.40$	5															
$0.40 < \Phi$	0															
03	LCD and Touch Panel black spots, white spots, contamination (non – display)	3.1 Round type: As following drawing $\Phi = (X+Y) / 2$  <table border="1" data-bbox="817 1115 1348 1279"> <thead> <tr> <th>Size(mm)</th> <th>Acceptable Q'ty</th> </tr> </thead> <tbody> <tr> <td><math>\Phi \leq 0.30</math></td> <td>Accept no dense</td> </tr> <tr> <td><math>0.30 &lt; \Phi \leq 0.50</math></td> <td>5</td> </tr> <tr> <td><math>0.50 &lt; \Phi</math></td> <td>0</td> </tr> </tbody> </table> * Densely spaced: No more than two spots within 3mm.	Size(mm)	Acceptable Q'ty	$\Phi \leq 0.30$	Accept no dense	$0.30 < \Phi \leq 0.50$	5	$0.50 < \Phi$	0	<b>2.5</b>					
		Size(mm)	Acceptable Q'ty													
$\Phi \leq 0.30$	Accept no dense															
$0.30 < \Phi \leq 0.50$	5															
$0.50 < \Phi$	0															
3.2 Line type: (As following drawing)  <table border="1" data-bbox="721 1478 1348 1809"> <thead> <tr> <th>Length(mm)</th> <th>Width(mm)</th> <th>Acceptable Q'ty</th> </tr> </thead> <tbody> <tr> <td><math>L \leq 10</math></td> <td><math>W \leq 0.1</math></td> <td>Accept no dense</td> </tr> <tr> <td><math>L \leq 10.0</math></td> <td><math>0.1 &lt; W \leq 0.25</math></td> <td>4</td> </tr> <tr> <td><math>L &gt; 10</math></td> <td>----</td> <td>Rejection</td> </tr> <tr> <td>----</td> <td><math>0.25 &lt; W</math></td> <td>Rejection</td> </tr> </tbody> </table> * Densely spaced: No more than two lines within 3mm.	Length(mm)	Width(mm)	Acceptable Q'ty	$L \leq 10$	$W \leq 0.1$	Accept no dense	$L \leq 10.0$	$0.1 < W \leq 0.25$	4	$L > 10$	----	Rejection	----	$0.25 < W$	Rejection	<b>2.5</b>
Length(mm)	Width(mm)	Acceptable Q'ty														
$L \leq 10$	$W \leq 0.1$	Accept no dense														
$L \leq 10.0$	$0.1 < W \leq 0.25$	4														
$L > 10$	----	Rejection														
----	$0.25 < W$	Rejection														

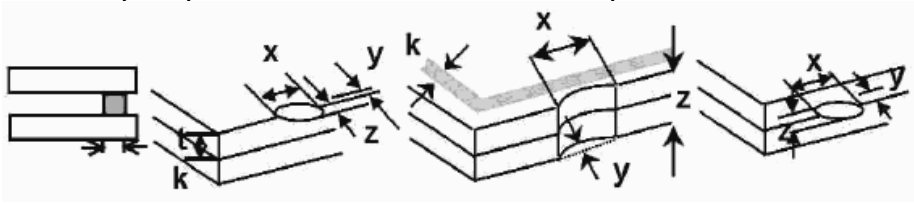
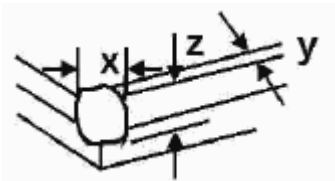
NO	Item	Criterion	AQL																		
04	Polarizer bubbles	If bubbles are visible, judge using black spot specifications, not easy to find, must check in specify direction <table border="1" data-bbox="852 248 1350 495" style="margin-left: auto; margin-right: auto;"> <thead> <tr> <th>Size <math>\Phi</math>(mm)</th> <th>Acceptable Q'ty</th> </tr> </thead> <tbody> <tr> <td><math>\Phi \leq 0.20</math></td> <td>Accept no dense</td> </tr> <tr> <td><math>0.20 &lt; \Phi \leq 0.50</math></td> <td>4</td> </tr> <tr> <td><math>0.50 &lt; \Phi \leq 1.00</math></td> <td>3</td> </tr> <tr> <td><math>1.00 &lt; \Phi</math></td> <td>0</td> </tr> <tr> <td>Total Q'ty</td> <td>4</td> </tr> </tbody> </table>	Size $\Phi$ (mm)	Acceptable Q'ty	$\Phi \leq 0.20$	Accept no dense	$0.20 < \Phi \leq 0.50$	4	$0.50 < \Phi \leq 1.00$	3	$1.00 < \Phi$	0	Total Q'ty	4	2.5						
Size $\Phi$ (mm)	Acceptable Q'ty																				
$\Phi \leq 0.20$	Accept no dense																				
$0.20 < \Phi \leq 0.50$	4																				
$0.50 < \Phi \leq 1.00$	3																				
$1.00 < \Phi$	0																				
Total Q'ty	4																				
05	Scratches	Follow NO.3 -2 Line Type.																			
06	Chipped glass	Symbols: x: Chip length      y: Chip width      z: Chip thickness k: Seal width      t: Glass thickness      a: LCD side length L: Electrode pad length 6.1 General glass chip: 6.1.1 Chip on panel surface and crack between panels:  <table border="1" data-bbox="402 1021 1219 1178" style="margin-left: auto; margin-right: auto;"> <thead> <tr> <th>z: Chip thickness</th> <th>y: Chip width</th> <th>x: Chip length</th> </tr> </thead> <tbody> <tr> <td><math>Z \leq 1/2t</math></td> <td>Not over viewing area</td> <td><math>x \leq 1/8a</math></td> </tr> <tr> <td><math>1/2t &lt; z \leq 2t</math></td> <td>Not exceed 1/3k</td> <td><math>x \leq 1/8a</math></td> </tr> </tbody> </table> <ul style="list-style-type: none"> <li>⊙ Unit: mm</li> <li>⊙ If there are 2 or more chips, x is the total length of each chip</li> </ul> 6.1.2 Corner crack:  <table border="1" data-bbox="402 1541 1219 1697" style="margin-left: auto; margin-right: auto;"> <thead> <tr> <th>z: Chip thickness</th> <th>y: Chip width</th> <th>x: Chip length</th> </tr> </thead> <tbody> <tr> <td><math>Z \leq 1/2t</math></td> <td>Not over viewing area</td> <td><math>x \leq 1/8a</math></td> </tr> <tr> <td><math>1/2t &lt; z \leq 2t</math></td> <td>Not exceed 1/3k</td> <td><math>x \leq 1/8a</math></td> </tr> </tbody> </table> <ul style="list-style-type: none"> <li>⊙ Unit: mm</li> <li>⊙ If there are 2 or more chips, x is the total length of each chip</li> </ul>	z: Chip thickness	y: Chip width	x: Chip length	$Z \leq 1/2t$	Not over viewing area	$x \leq 1/8a$	$1/2t < z \leq 2t$	Not exceed 1/3k	$x \leq 1/8a$	z: Chip thickness	y: Chip width	x: Chip length	$Z \leq 1/2t$	Not over viewing area	$x \leq 1/8a$	$1/2t < z \leq 2t$	Not exceed 1/3k	$x \leq 1/8a$	2.5
z: Chip thickness	y: Chip width	x: Chip length																			
$Z \leq 1/2t$	Not over viewing area	$x \leq 1/8a$																			
$1/2t < z \leq 2t$	Not exceed 1/3k	$x \leq 1/8a$																			
z: Chip thickness	y: Chip width	x: Chip length																			
$Z \leq 1/2t$	Not over viewing area	$x \leq 1/8a$																			
$1/2t < z \leq 2t$	Not exceed 1/3k	$x \leq 1/8a$																			

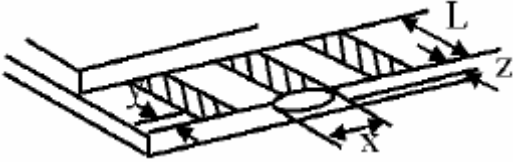
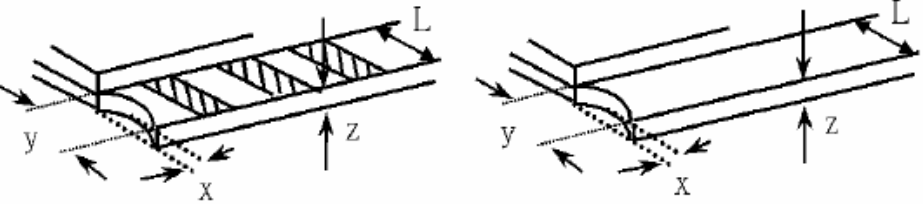
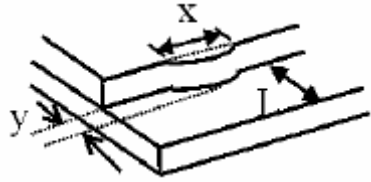
NO	Item	Criterion	AQL																
07	Glass crack	<p>Symbols:            x: Chip length      y: Chip width      z: Chip thickness            k: Seal width      t: Glass thickness      a: LCD side length            L: Electrode pad length</p> <p>7.2 Protrusion over terminal:            7.2.1 Chip on electrode pad:</p>  <table border="1" data-bbox="544 645 1230 801"> <tr> <td>y: Chip width</td> <td>x: Chip length</td> <td>z: Chip thickness</td> </tr> <tr> <td><math>y \leq 0.5\text{mm}</math></td> <td><math>x \leq 1/8a</math></td> <td><math>0 &lt; z \leq t</math></td> </tr> </table> <p>7.2.2            Non-conductive portion:</p>  <table border="1" data-bbox="544 1160 1230 1317"> <tr> <td>y: Chip width</td> <td>x: Chip length</td> <td>z: Chip thickness</td> </tr> <tr> <td><math>y \leq L</math></td> <td><math>x \leq 1/8a</math></td> <td><math>0 &lt; z \leq t</math></td> </tr> </table> <p>⊙ If there chipped area touches the ITO terminal, over 2/3 of the ITO must remain and be inspected according to electrode terminal specifications.            ⊙ If the product will be heat sealed by the customer, the alignment mark must not be damaged.</p> <p>7.2.3 Substrate protuberance and internal crack</p>  <table border="1" data-bbox="863 1637 1305 1787"> <tr> <td>y: width</td> <td>x: length</td> </tr> <tr> <td><math>y \leq 1/3L</math></td> <td><math>X \leq a</math></td> </tr> </table>	y: Chip width	x: Chip length	z: Chip thickness	$y \leq 0.5\text{mm}$	$x \leq 1/8a$	$0 < z \leq t$	y: Chip width	x: Chip length	z: Chip thickness	$y \leq L$	$x \leq 1/8a$	$0 < z \leq t$	y: width	x: length	$y \leq 1/3L$	$X \leq a$	2.5
y: Chip width	x: Chip length	z: Chip thickness																	
$y \leq 0.5\text{mm}$	$x \leq 1/8a$	$0 < z \leq t$																	
y: Chip width	x: Chip length	z: Chip thickness																	
$y \leq L$	$x \leq 1/8a$	$0 < z \leq t$																	
y: width	x: length																		
$y \leq 1/3L$	$X \leq a$																		



NO	Item	Criterion	AQL
08	Cracked glass	The LCD with extensive crack is not acceptable.	2.5
09	Backlight elements	9.1 Illumination source flickers when lit. 9.2 Spots or scratches that appear when lit must be judged. Using LCD spot, lines and contamination standards. 9.3 Backlight doesn't light or color is wrong.	2.5 2.5 0.65
10	Bezel	Bezel must comply with product specifications.	2.5
11	PCB、COB	11.1 COB seal may not have pinholes larger than 0.2mm or contamination. 11.2 COB seal surface may not have pinholes through to the IC. 11.3 The height of the COB should not exceed the height indicated in the assembly diagram. 11.4 There may not be more than 2mm of sealant outside the seal area on PCB. And there should be no more than three places. 11.5 Parts on PCB must be the same as on the production characteristic chart, There should be no wrong parts, missing parts or excess parts. 11.6 The jumper on the PCB should conform to the product characteristic chart.	2.5 2.5 2.5 2.5 0.65 0.65
12	FPC	12.1 FPC terminal damage $\leq 1/2$ FPC terminal width and can not affect the function , we judge accept. 12.2 FPC alignment hole damage $\leq 1/2$ alignment area and can not affect the function , we judge accept.	2.5 2.5
13	Soldering	13.1 No cold solder joints, missing solder connections, oxidation or icicle. 13.2 No short circuits in components on PCB or FPC.	2.5 0.65

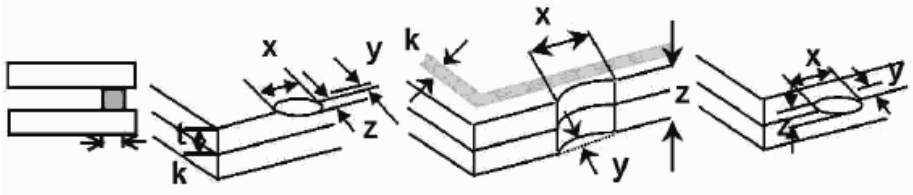
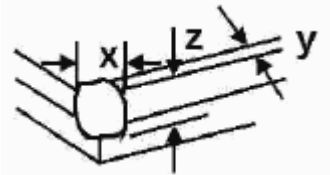

NO	Item	Criterion	AQL												
14	Touch Panel Chipped glass	<p>Symbols:            x: Chip length                      y: Chip width                      z: Chip thickness            k: Seal width                      t: Touch Panel Total thickness      a: LCD side length            L: Electrode pad length</p> <p>14.1 General glass chip:            14.1.1 Chip on panel surface and crack between panels:</p>  <table border="1" data-bbox="400 763 1220 976"> <tr> <td>z: Chip thickness</td> <td>y: Chip width</td> <td>x: Chip length</td> </tr> <tr> <td><math>Z \leq t</math></td> <td><math>\leq 1/2 k</math> and not over viewing area</td> <td><math>x \leq 1/8a</math></td> </tr> </table> <p>⊙ Unit: mm            ⊙ If there are 2 or more chips, x is the total length of each chip</p> <p>14.1.2 Corner crack:</p>  <table border="1" data-bbox="400 1359 1220 1572"> <tr> <td>z: Chip thickness</td> <td>y: Chip width</td> <td>x: Chip length</td> </tr> <tr> <td><math>z \leq t</math></td> <td><math>\leq 1/2 k</math> and not over viewing area</td> <td><math>x \leq 1/8a</math></td> </tr> </table> <p>⊙ Unit: mm            ⊙ If there are 2 or more chips, x is the total length of each chip</p>	z: Chip thickness	y: Chip width	x: Chip length	$Z \leq t$	$\leq 1/2 k$ and not over viewing area	$x \leq 1/8a$	z: Chip thickness	y: Chip width	x: Chip length	$z \leq t$	$\leq 1/2 k$ and not over viewing area	$x \leq 1/8a$	2.5
z: Chip thickness	y: Chip width	x: Chip length													
$Z \leq t$	$\leq 1/2 k$ and not over viewing area	$x \leq 1/8a$													
z: Chip thickness	y: Chip width	x: Chip length													
$z \leq t$	$\leq 1/2 k$ and not over viewing area	$x \leq 1/8a$													

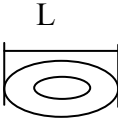
NO	Item	Criterion	AQL							
15	Touch Panel(Fish eye)	<table border="1"> <thead> <tr> <th>SIZE(mm)</th> <th>Acceptable Q'ty</th> </tr> </thead> <tbody> <tr> <td><math>L \leq 0.7</math></td> <td>Accept no dense</td> </tr> <tr> <td><math>L &gt; 0.7\text{mm}</math></td> <td>0</td> </tr> </tbody> </table>	SIZE(mm)	Acceptable Q'ty	$L \leq 0.7$	Accept no dense	$L > 0.7\text{mm}$	0		2.5
		SIZE(mm)	Acceptable Q'ty							
		$L \leq 0.7$	Accept no dense							
$L > 0.7\text{mm}$	0									
Newton ring dimension $\leq 1/2$ touch panel area and not affect font and line distortion( $\leq 2.5\%$ ), it is acceptable.	2.5									
Touch Panel Linearity	Less than 2.5% is acceptable.	2.5								
18	LCD Ripple	Touch the touch panel, can not see the LCD ripple. Pen: R 1.0mm silicon rubber. Operation Force: 80g	2.5							
19	General appearance	19.1 Pin type must match type in specification sheet.	0.65							
		19.2 LCD pin loose or missing pins.	0.65							
		19.3 Product packaging must the same as specified on packaging specification sheet.	0.65							
		19.4 Product dimension and structure must conform to product specification sheet.	0.65							



## **13. Handling Precaution:**

### 13-1 Handling of LCM

- Don't give external shock.
- Don't apply excessive force on the surface.
- Liquid in LCD is hazardous substance. Must not lick and swallow. when the liquid is attach to your hand, skin, cloth etc. Wash it out thoroughly and immediately.
- Don't operate it above the absolute maximum rating.
- Don't disassemble the LCM.
- The operators should be grounded whenever he/she comes into contact with the module. Never touch any of the conductive parts such as the LSI pads, the copper leads on the PCB and the interface terminals with any parts of the human body.
- The modules should be kept in antistatic bags or other containers resistant to static for storage.
- The module is coated with a film to protect the display surface. Be care when peeling off this protective film since static electricity may be generated.

### 13-2 Storage

- Store in an ambient temperature of  $25\pm 10^{\circ}\text{C}$ , and in a relative humidity of  $50\pm 10\%\text{RH}$ . Don't expose to sunlight or fluorescent light.
- Storage in a clean environment, free from dust, active gas, and solvent.
- Store in anti-static electricity container.
- Store without any physical load.

### 13-3 Soldering

- Use only soldering irons with proper grounding and no leakage.
- Iron: No higher than  $280\pm 10^{\circ}\text{C}$  and less than 3 sec during Hand soldering.
- Rewiring: no more than 2 times.

## **14. Guarantee:**

Our products meet requirements of the environment.

YEEBO ROHS requirement is based on European Union Directive 2011/65/EU (ROHS) Requirements and Update.