



SPECIFICATION FOR LCD MODULE

MODULE NO: YB-YG800480S12A-C-A0

Doc.Version:00

Customer Approval:

<input type="checkbox"/> Accept	<input type="checkbox"/> Reject
---------------------------------	---------------------------------

YEEBO	NAME	SIGNATURE	DATE
Prepare	Electronic Engineer		2014.4.25
Check	Mechanical Engineer		2014.4.25
Verify			2014.4.25
Approval			2014.4.25

■ APPROVAL FOR SPECIFICATIONS ONLY

□ APPROVAL FOR SPECIFICATIONS AND SAMPLE

WIMRD005-02-C



2. Table of Contents:

NO	CONTENTS	PAGE
1	Revision History	1
2	Table of Contents	2
3	Module Numbering System	3
4	General Specification	4
5	LCM drawing	5
6	Electrical Characteristics	6
7	Optical Characteristics	13
8	Interface Pin Assignment	15
9	Block Diagram	17
10	Backlight	18
11	Standard Specification for Reliability	19
12	Specification of Quality Assurance	21
13	Handling Precaution	29
14	Guarantee	29



3. Module Numbering System:

(Example)

YB- T G 240320 S 01 D -T - A0

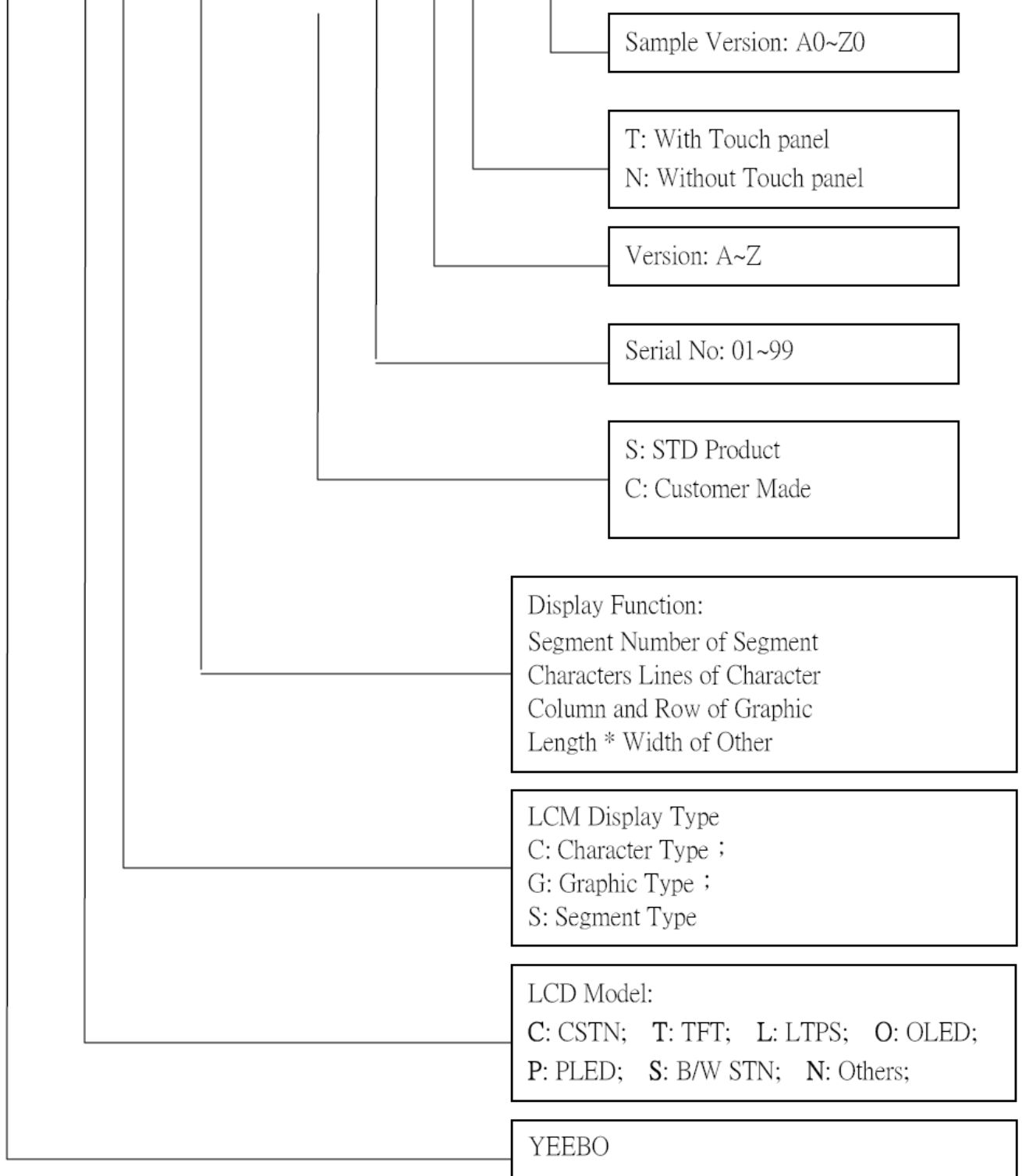



4. General Specification:

ITEM	CONTENTS
Module Size	190.0 (W) * 112.5 (H) * 6.6 (T) mm
Module Size(With FPC)	235.85(W) * 142.32 (H) * 6.6 (T) mm
Display Size(Diagonal)	7.0 inch
Display Format	800(RGB)* 480 Pixels
Active Area	153.6(W) *86.64 (H) mm
Dots Pitch	0.192*0.1805 mm
LCD Type	TFT (16.7M)/ Transmissive / NW
Touch panel Type	OLGS / PCTP
View Angle	6:00 O'clock
Controller IC	HX8264+HX8678
CTP IC	ILI2303
Weight	TBD



5. LCM drawing:

Count drawing & Spec. revision record during discussion with customer	
Rev. #1	Revision content description
	FIRST ISSUE
Date	2014-04-18

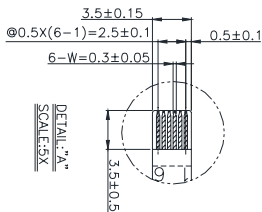
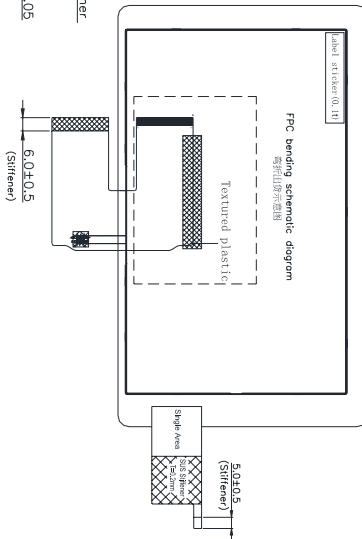
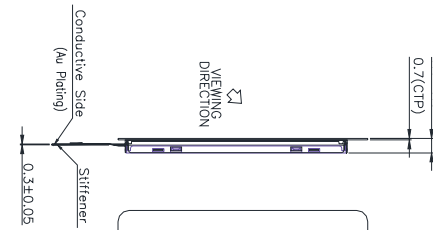
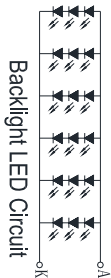
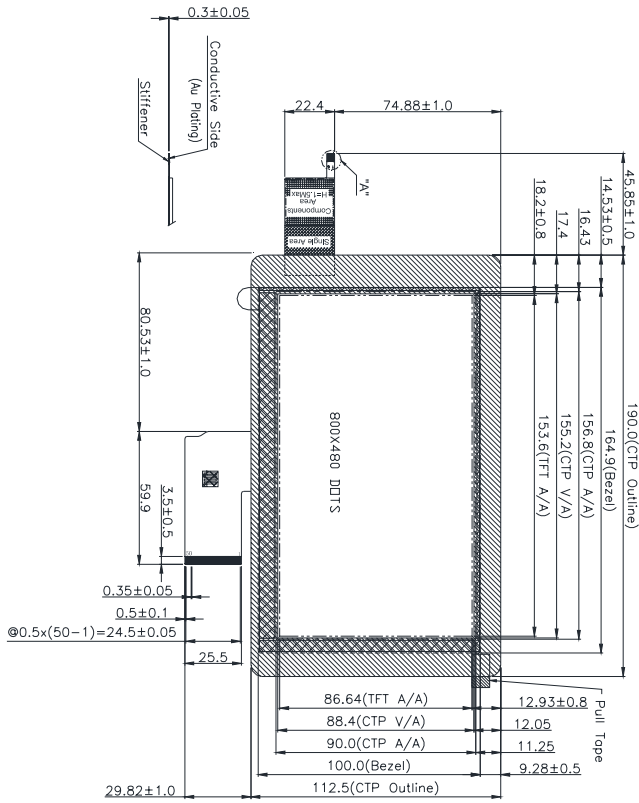

TOUCH PANEL	4.3	DITHB
PIN ASSIGNMENT	44	GND
No. Symbol	45	NC
1	VDD	NC
2	RESET	47
3	INT	48
4	SCL	49
5	SDA	50
6	GND	K

LCD MODULE	1
FPC PIN OUT	1
PIN ASSIGNMENT	1
No. Symbol	1
1	GND
2	VCOM
3	DYDD
4	MODE
5	DE
6	VS
7	HS
8	B7
9	B6
10	B5
11	B4
12	B3
13	B2
14	B1
15	B0
16	G7
17	G6
18	G5
19	G4
20	G3
21	G2
22	G1
23	G0
24	R7
25	R6
26	R5
27	R4
28	R3
29	R2
30	R1
31	RO
32	GND
33	DCLK
34	GND
35	SHLR
36	LEPN
37	VDDG
38	VEEG
39	AVDD
40	RSTB
41	NC
42	VCOM

- Specification:**
1. Display mode: 7.0" TFT/ Normal White/ Transmissive
 2. Color depth: 16.7M Colors
 3. Viewing direction: 6 O'clock
 4. Operating temperature: -0°C to +60°C
 5. Drive IC: HX8264+HX8678
 6. Backlight: 18 CHIP WHITE LED/ LCM Luminaire(with T/P); 200 cd/m² (TYP)
 7. V=9.6V(TYP)/ If=120mA
 8. ROHS compliant
 9. Glass Type: OLGs PCTP
 10. Channel NO: 28(X) x 16(Y)
 11. Drive IC is: IL2303

YEEBO		MOD. Name	YB-YG800480S12A-C-A	DESIGNED	CHECKED	VERIFIED	APPROVED	FILE NAME
UNIT	SIZE	SCALE	DESIGNED	2014-04-18				Count Dwg.
mm	A4	N-T-S	連翹班					
Sheet		1						
Of		1						



6. Electrical Characteristics

6-1 Absolute Maximum Ratings

TFT Driver IC HX8264+HX8678 Parameter

(Ta=25°C VSS=0V)

Item	Symbol	Min.	Type	Max.	Unit	Remark
Power Supply voltage	DVDD	-0.3	-	6.0	Volt	GND=0
	VDDG	0.3	-	20.0	Volt	GND=0
	VEEG	-20	-	0.3	Volt	GND=0
	AVDD	0.5	-	14.0	Volt	GND=0
Common Voltage	VCOM	0		5	Volt	GND=0
Logic Signal Input Level	VI	-0.3		DVDD+0.3	Volt	GND=0
Operating Temperature	Topr	0	-	+60	°C	-
Storage Temperature	Tstg	-10	-	+70	°C	-

Note1: Absolute maximum rating is the limit value beyond which the IC maybe broken.
They do not assure operations.

Touch panel controller ILI2303 Parameter

Item	Symbol	Min.	Type	Max.	Unit	Humidity
Supply Voltage	VDD	-0.3	-	+3.6	Volt	Note1

Note1: Absolute maximum rating is the limit value beyond which the IC maybe broken.
They do not assure operations.



6-2 Operating Conditions

(Ta=25°C)

Item	Symbol	Condition	Min.	Typ.	Max.	Unit
Power Supply voltage	DVDD	-	3.0	3.3	3.6	Volt
	VDDG	-	14.5	15.0	15.5	Volt
	VEEG		-7.5	-7.0	-6.5	Volt
	AVDD		9.85	10	10.15	Volt
Common Voltage	VCOM		-	3.72	-	Volt
Input Voltage Level Note (1)	VIH	-	0.7*DVDD	-	VCC	V
	VIL	-	0		0.3*DVDD	V
Current of Power Supply	IDD	VDD=3.3V	-	TBD	-	mA
	IAVDD	AVDD=10.0V	-	TBD	-	mA
	IVDDG	VDDG=15.0V		TBD		mA
	IVEEG	VEEG=-7.0V		TBD		mA

Note (1): HSYNC, VSYNC, DE, Digital Data

Note (2): Be sure to apply the power voltage as the power sequence spec.

Note (3): DGND=AGND=GND=0V

Touch panel controller ILI2303

Item	Symbol	Condition	Min.	Typ.	Max.	Unit
Power Supply	V _{DD}	-	3.0	3.3	3.3	Volt

6-3 Timing Characteristics

6-3-1 TFT Driver IC HX8264+HX8678

Electrical AC Characteristics

Item	Symbol	Min.	Typ.	Max.	Unit	Note
DCLK cycle time	Tcph	25			ns	
DCLK frequency	fclk		30	40	MHz	
DCLK pulse duty	Tcwh	40	50	60	%	
VSD setup time	Tvst	8			ns	
VSD hold time	Tvhd	8			ns	
HSD setup time	Thst	8			ns	
HSD hold time	Thhd	8			ns	
Data setup time	Tdsu	8			ns	
Data hold time	Tdhd	8			ns	
DE setup time	Tesu	8			ns	
DE hold time	Tehd	8			ns	
Horizontal display area	thd		800		Tcph	
HSD period time	th		928		Tcph	
HSD pulse width	thpw	1	48		Tcph	
HSD back porch	thb		40		Tcph	
HSD front porch	thfp		40		Tcph	
Vertical display area	tvd		480		th	
VSD period time	tv		525		th	
VSD pulse width	tvpw		3		th	
VSD back porch	tvb		29		th	
VSD front porch	tvfp		13		th	

Timing Diagram of Interface Signal

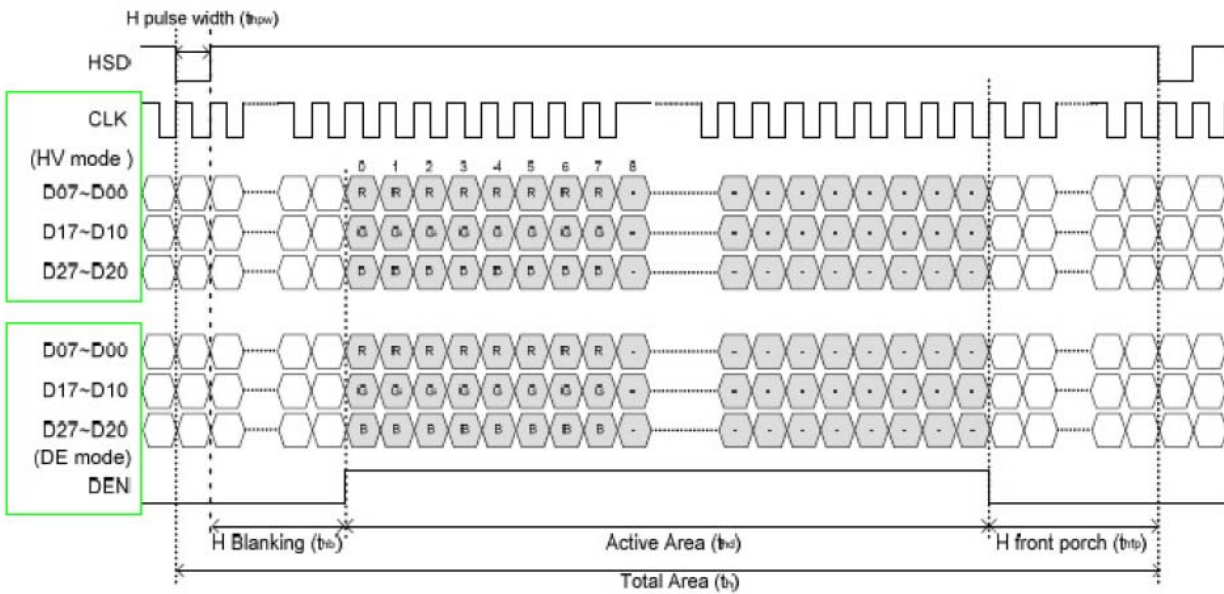
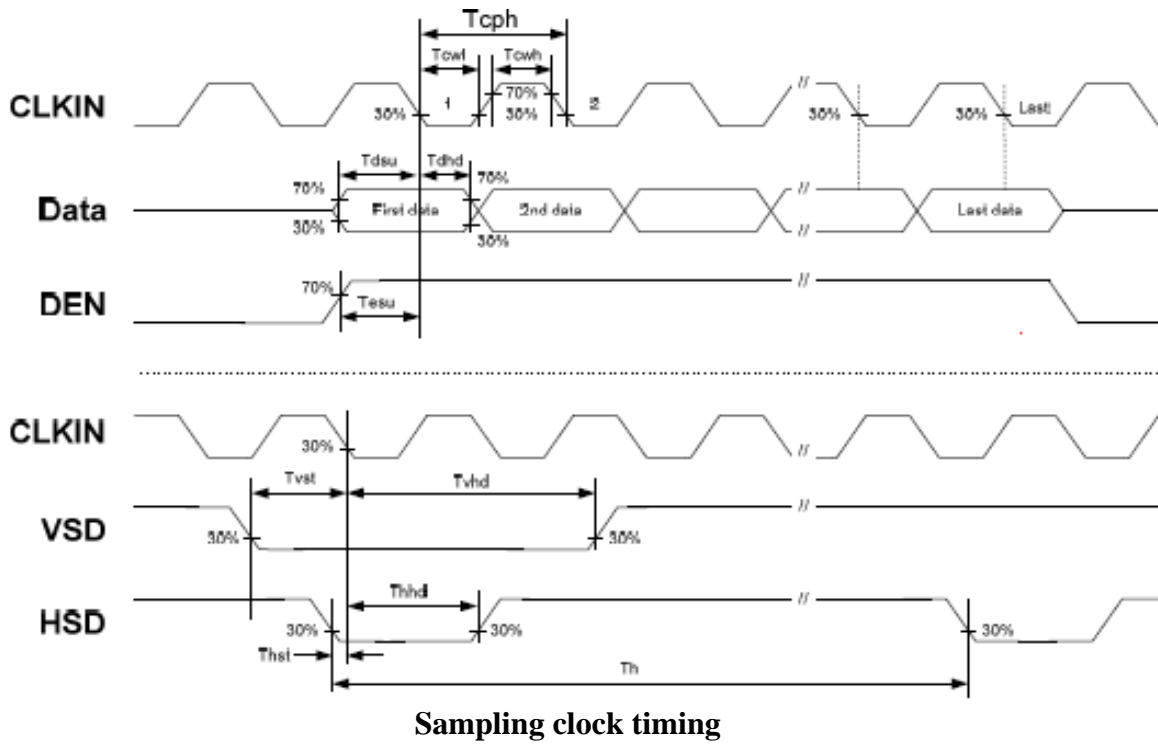

Horizontal display timing range

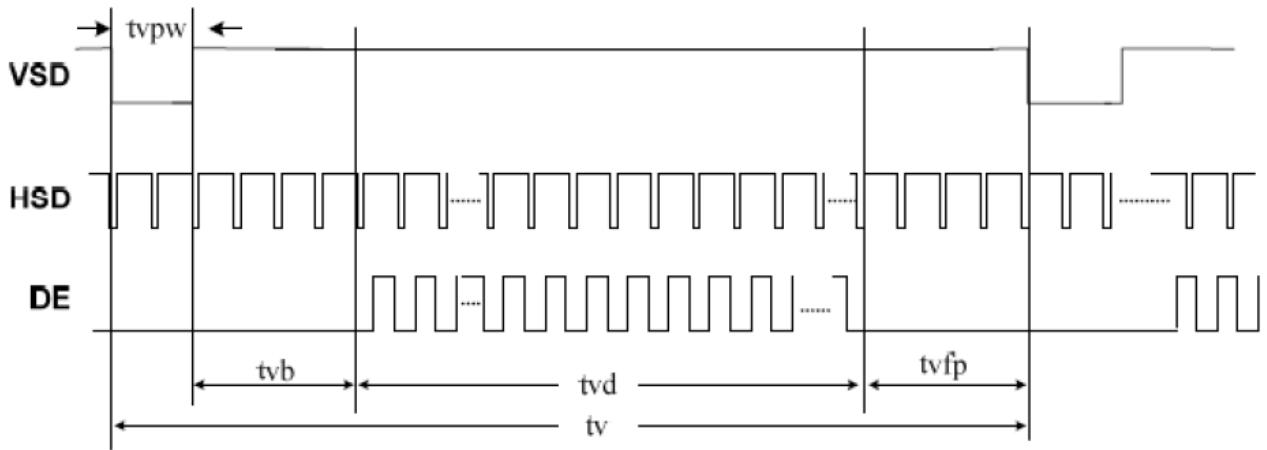

Vertical timing

Power Sequence

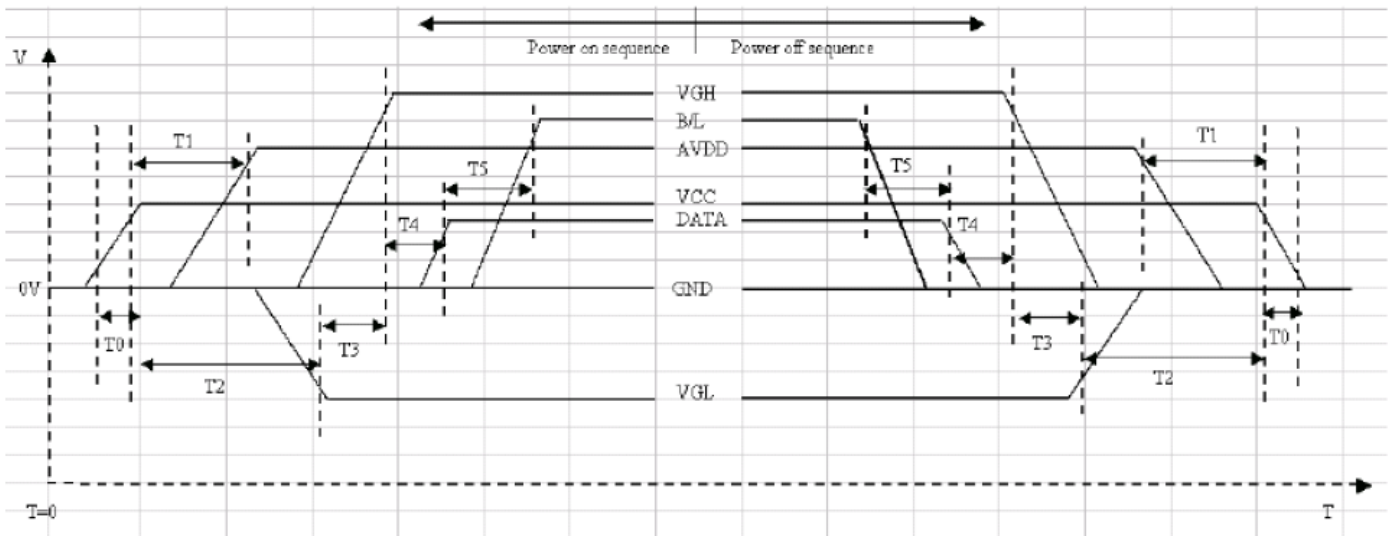

Item	Min.	Typ.	Max.	Unit
T0	0.5	--	20	msec
T1	16			msec
T2	20			msec
T3	10			msec
T4	10		50	msec
T5	50			msec

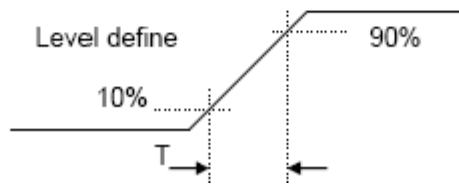

Power On Sequence: VCC-> AVDD -> VGL -> VGH -> Data -> B/L

Power Off Sequence: B/L-> Data -> VGH -> VGL -> AVDD -> VCC

Notes: Data include R0~R7, G0~G7, B0~B7, HSD, VSD, DCLK, SHLR, UPDN, DE MODE, RSTB, STBYB, SHLR, UPDN, DITH

6-3-2 Touch panel controller IC Input Timing (Reference to ILI2303)

I²C interface

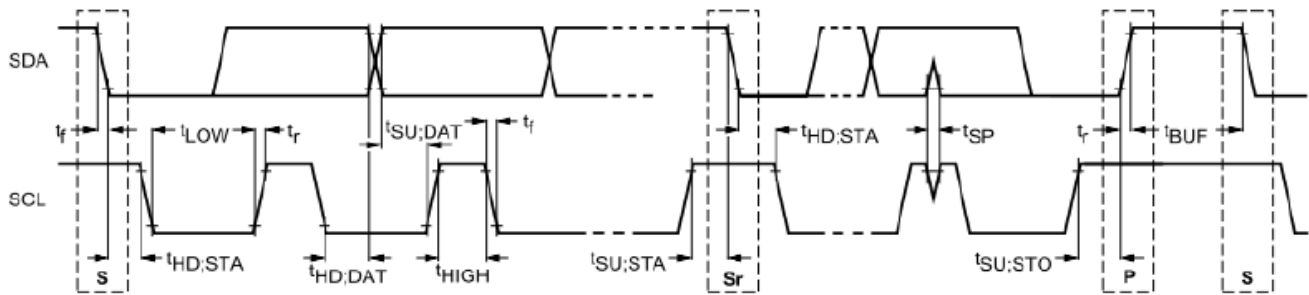

Symbol	Parameter	100KHz			400KHz		
		Min	Max	Unit	Min	Max	Unit
f _{SCL}	SCL clock frequency	0	100	kHz	0	400	kHz
t _{HD:STA}	Hold time (repeated) START condition. After this period, the first clock pulse is generated	4.0	–	μs	0.6	–	μs
t _{LOW}	LOW period of the SCL clock	4.7	–	μs	1.3	–	μs
t _{HIGH}	HIGH period of the SCL clock	4.0	–	μs	0.6	–	μs
t _{SU:STA}	Set-up time for a repeated START condition	4.7	–	μs	0.6	–	μs
t _{HD:DAT}	Data hold time	5.0	–	μs	0	0.9	μs
t _{SU:DAT}	Data set-up time	250	–	ns	100	–	ns
t _r	Rise time of both SDA and SCL signals	–	1000	ns	–	300	ns
t _f	Fall time of both SDA and SCL signals	–	300	ns	–	300	ns
t _{SU:STO}	Set-up time for STOP condition	4.0	–	μs	0.6	–	μs
t _{BUF}	Bus free time between a STOP and START condition	4.7	–	μs	1.3	–	μs



7. Optical Characteristics:

Item	Symbol	Conditions	Specifications			Unit	Note	
			Min	Typ	Max			
Transmittance	T(%)	-	-	6.27	-	-	-	
Contrast Ratio	CR	$\Theta=0$ Normal Viewing angle	400	500	-		(1) (2)	
Response time	TR+TF	-	-	25	35	ms	(1) (3)	
Viewing angle	Hor.	Θ_{x+}	$CR \geq 10$	-	70	-	deg.	-
		Θ_{x-}		-	70	-		
	Ver.	Θ_{y+}		-	50	-		
		Θ_{y-}		-	50	-		

Measuring Condition

1. Measuring surrounding: dark room
2. Ambient temperature: $25 \pm 2^\circ\text{C}$
3. 30 min. Warm-up time.

Color of CIE Coordinate:

Item	Symbol	Condition	Min.	Typ.	Max.	Brightness	
Chromaticity Coordinates (Transmissive)	Red	x	-	0.6143	-	TBD cd/m^2	
		y	-	0.3667	-		
	Green	x	BacklightColor degree X=0.28 Y=0.28 Brightness=TBD cd/m^2	-	0.3543	-	TBD cd/m^2
		y		-	0.5903	-	
	Blue	x		-	0.1571	-	TBD cd/m^2
		y		-	0.1343	-	
	White	x		-	0.3031	-	TBD cd/m^2
		y		-	0.3379	-	

Note (1) Definition of Viewing Angle :

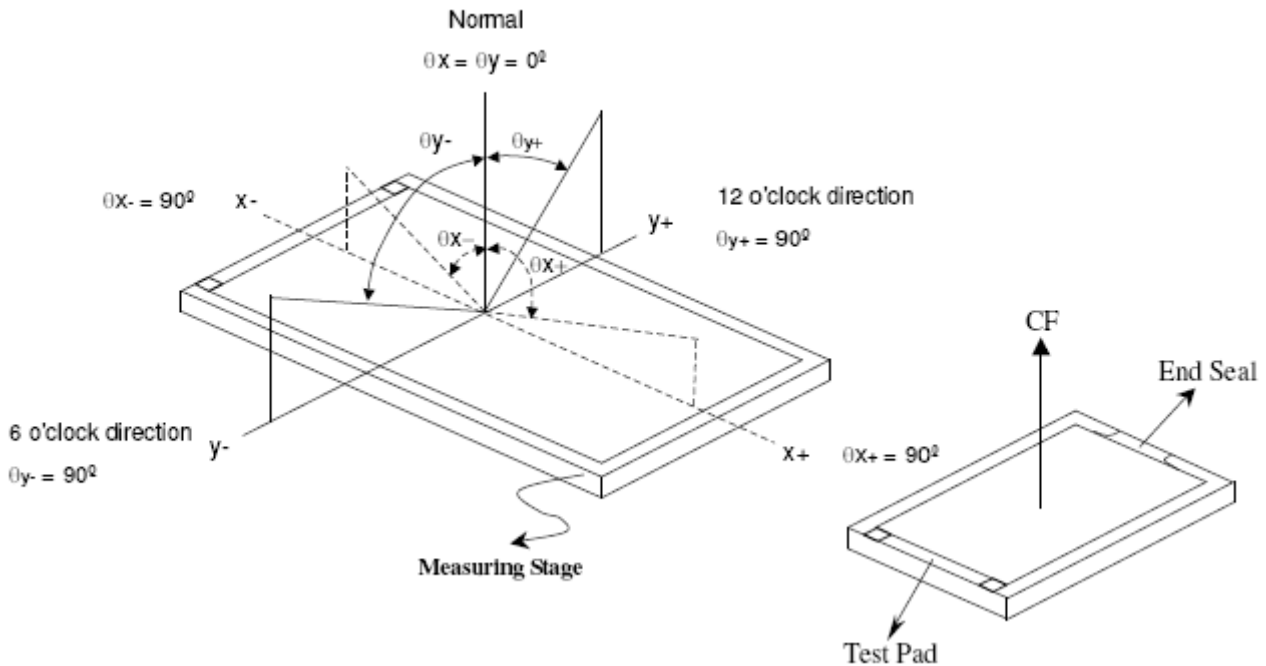

Note (2) Definition of Contrast Ratio(CR) :
measured at the center point of panel

$$\text{Contrast ratio (CR)} = \frac{\text{Photo detector output when LCD is at "White" state}}{\text{Photo detector output when LCD is at "Black" state}}$$

Note (3) Definition of Response Time : Sum of TR and TF

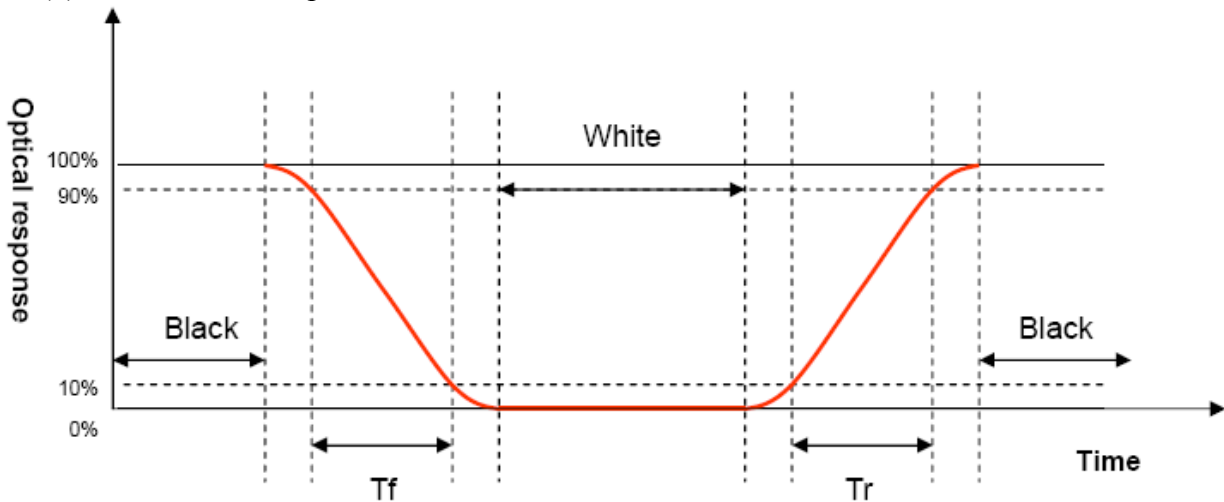



8. Interface Pin Assignment:

8-1 LCM FPC Interface

No.	Symbol	Function
1	GND	Power ground
2	VCOM	Common Voltage
3	DVDD	Digital Power
4	MODE	DE/SYNC mode select. Normally pull high H:DE mode. L:HSD/VSD mode
5	DE	Data Enable signal
6	VS	Vertical sync input. Negative polarity
7	HS	Horizontal sync input. Negative polarity
8~15	B7~B0	Blue Data Input
16~23	G7~G0	Green Data Input
24~31	R7~R0	Red Data Input
32	GND	Power ground
33	DCLK	Clock Input
34	GND	Power ground
35	SHLR	Left or Right Display Control
36	UPDN	Up / Down Display Control
37	VDDG	Positive Power for TFT
38	VEEG	Negative Power for TFT
39	AVDD	Analog Power
40	RSTB	Global reset pin. Active low to enter reset state. Suggest to connecting with an RC reset circuit for stability. Normally pull high. (R=10K , C=1μF)
41	NC	Not connect
42	VCOM	Common Voltage
43	DITHB	Dithering setting, Normally pull high. DITH="H" 6bit resolution(last 2 bit of input data truncated)
44	GND	Power ground
45	NC	No Connection
46	NC	No Connection
47	NC	No Connection
48	NC	No Connection
49	A	Black Light+
50	K	Black Light -

Note: DVDD=VCC=VDD, VDDG=VGH, VEEG=VGL

Module P/N: YB-YG800480S12A-C-A0

Doc.Version:00



8-2 CTP Interface Pin

No.	Symbol	Function
1	VDD	Analog power supply.
2	RESET	RESET.
3	INT	External interrupt pin to host.
4	SCL	Serial clock pin for I2C interface.
5	SDA	Serial data pin for I2C interface.
6	GND	Ground.

Note: I2C interface

9. Block Diagram:

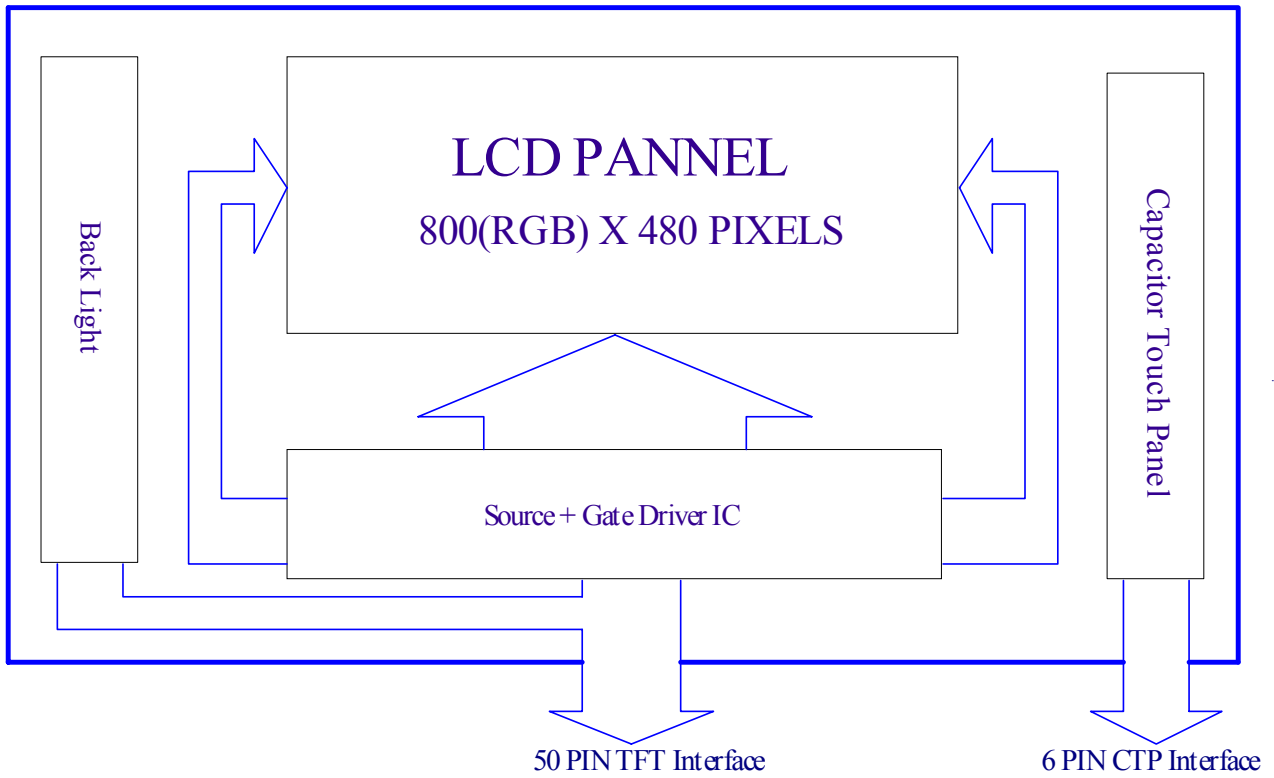

10. Backlight:

1. Standard Lamp Styles (Edge Lighting Type):
The LED chips are distributed over the edge light area of the illumination unit, which gives the less power consumption:
2. The Main Advantages of the LED Backlight are as following:
 - 2.1 The brightness of the backlight can simply be adjusted.
By a resistor or a potentiometer.

3. Data About LED Backlight:

PARAMETER	Sym.	Min.	Typ.	Max.	Unit	Test Condition	Note
Supply Current	I	-	120	-	mA	Vf=9.6V	
Supply Voltage	V	-	9.6	-	V	If=120mA	
Reverse Voltage	V _R	-	-	5.0	V		
Luminous Intensity for LCM	I _v	-	200	-	Cd/m ²	If=120mA	2
Uniformity for LCM	-	70	-	-	%	If=120mA	3
Life Time	-	20000	-	-	Hr.		4
Color	White						

NOTE:

1. Backlight Only
2. Average Luminous Intensity of P1-P9
3. Uniformity = Min/Max * 100%
4. LED life time defined as follows: The final brightness is at 70% of original brightness

Internal Circuit Diagram

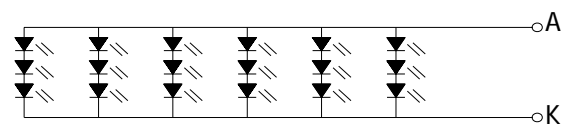
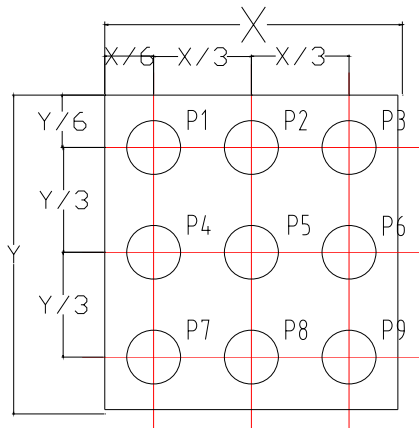

Backlight LED Circuit

11. Standard Specification for Reliability:

11-1. Standard Specifications for Reliability of LCD Module

No	Item	Description
01	High temperature operation	The sample should be allowed to stand at 70°C for 120 hours under driving condition and then returning it to normal temperature condition, and allowing it stand for 2 hours.
02	Low temperature operation	The sample should be allowed to stand at -20°C for 120 hours under driving condition and then returning it to normal temperature condition, and allowing it stand for 2 hours.
03	High temperature storage	The sample should be allowed to stand at 80°C for 240 hours under no-load condition, and then returning it to normal temperature condition, and allowing it stand for 2 hours.
04	Low temperature storage	The sample should be allowed to stand at -30°C for 240 hours under no-load condition, then returning it to normal temperature condition, and allowing it stand for 2 hours.
05	Moisture storage	The sample should be allowed to stand at 60°C, 90%RH MAX for 240 hours under no-load condition, then taking it out and drying it at normal temperature for 2 hours.
06	Thermal shock storage	The sample should be allowed to stand the following 10 cycles : -30°C for 30 minutes → normal temperature for 5 minutes → +80°C for 30 minutes → normal temperature for 5 minutes, as one cycle.
07	Packing vibration	Frequency range : 10Hz ~ 55Hz Amplitude of vibration : 1.5mm Sweep time: 12 min X, Y, Z 2 hours for each direction.
08	Packing drop test	According to ISTA 1A 2001.
09	Electrical Static Discharge	Air: ±6KV 150pF/330Ω 5 times
		Contact: ±4KV 150pF/330Ω 5 time

11 - 2. Testing Conditions and Inspection Criteria



For the final test the testing sample must be stored at room temperature for 24 hours, after the tests listed in Table 11-1, Standard specifications for Reliability have been executed in order to ensure stability.

No	Item	Test Model	In section Criteria
01	Current Consumption	Refer To Specification	The current consumption should conform to the product specification.
02	Contrast	Refer To Specification	After the tests have been executed, the contrast must be larger than half of its initial value prior to the tests.
03	Appearance	Visual inspection	Defect free.

11- 3. MTBF

MTBF	Functions, performance, appearance, etc. shall be free from remarkable deterioration within 50,000 hours under ordinary operating and storage conditions room temperature ($25\pm 5^{\circ}\text{C}$), normal humidity ($50\pm 10\%$ RH), and in area not exposed to direct sun light.
------	---



12. Specification of Quality Assurance:

12-1. Purpose

This standard for Quality Assurance should affirm the quality of LCD module products to supply to purchaser by YEEBO CORPORATION (Supplier).

12-2. Standard for Quality Test

a. Inspection:

Before delivering, the supplier should take the following tests, and affirm the quality of product.

b. Electro-Optical Characteristics:

According to the individual specification to test the product.

c. Test of Appearance Characteristics:

According to the individual specification to test the product.

d. Test of Reliability Characteristics:

According to the definition of reliability on the specification for testing products.

e. Delivery Test:

Before delivering, the supplier should take the delivery test.

(i) Test method: According to MIL-STD105E.General Inspection Level II take a single time.

(ii) The defects classify of AQL as following:

Major defect: AQL = 0.65%

Minor defect: AQL = 2.5%

Total defects: AQL = 2.5%

12-3. Non- conforming Analysis & Deal With Manners

a. Non- conforming Analysis:

(i) Purchaser should supply the detail data of non- conforming sample and the non- conforming.

(ii) After accepting the detail data from purchaser, the analysis of non- conforming should be finished in two weeks.

(iii) If supplier can not finish analysis on time, must announce purchaser before 3 days.

b. Disposition of non- conforming:

(i) If find any product defect of supplier during assembly time, supplier must change the good product for every defect after recognition.

(ii) Both supplier and customer should analyze the reason and discuss the disposition of non- conforming when the reason of nonconforming is not sure.

12-4. Agreement items

Both sides should discuss together when the following problems happen.

a. There is any problem of standard of quality assurance, and both sides should think that must be modified.

b. There is any argument item which does not record in the standard of quality assurance.

c. Any other special problem.

12-5. Standard of The Product Appearance Test

a. Manner of appearance test:

- (i) The test must be under 20W × 2 or 40W fluorescent light, and the distance of view must be at 30±5cm.
- (ii) When test the model of transmissive product must add the reflective plate.
- (iii) The test direction is base on around 10° of vertical line.
- (iiii) Temperature: 25±5°C Humidity: 60±10%RH

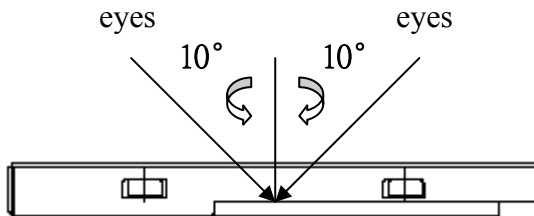

(iv) Definition of area:

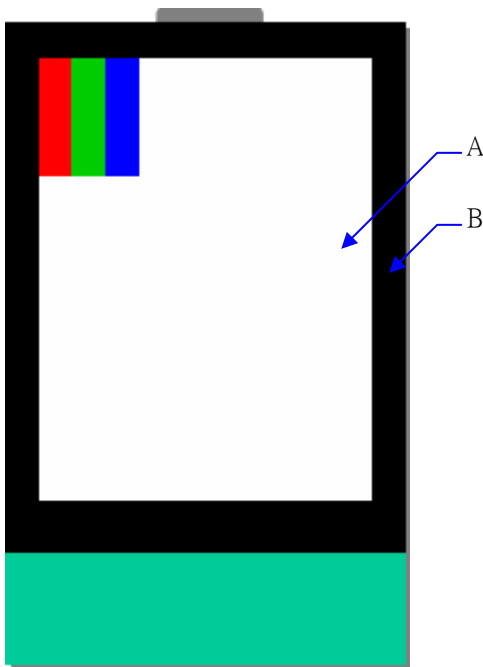

- A. Area: Viewing area.
- B. Area: Out of viewing area.
(Outside viewing area)

b. Basic principle:

- (i) It will accord to the AQL when the standard can not be described.
- (ii) The sample of the lowest acceptable quality level must be discussed by both supplier and customer when any dispute happened.
- (iii) Must add new item on time when it is necessary.

c. Standard of inspection: (Unit: mm)

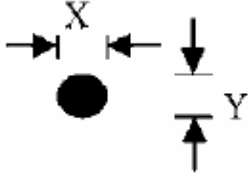
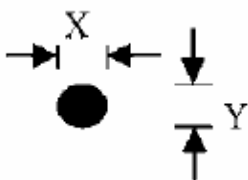
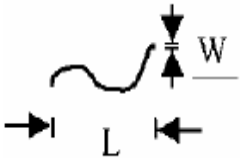
NO	Item	Criterion	AQL													
01	Electrical Testing	1.1 Missing vertical, horizontal segment, segment contrast defect. 1.2 Missing character, dot or icon. 1.3 Display malfunction. 1.4 No function or no display. 1.5 Current consumption exceeds product specifications. 1.6 LCD viewing angle defect. 1.7 Mixed product types. 1.8 Flicker	0.65													
02	Black or White spots or Bright spots or Color spots on LCD (Display only)	2.1 Dot dimension as below drawing: $\Phi = (X+Y) / 2$  <table border="1" data-bbox="817 728 1348 891"> <thead> <tr> <th>Size(mm)</th> <th>Acceptable Q'ty</th> </tr> </thead> <tbody> <tr> <td>$\Phi \leq 0.20$</td> <td>Accept no dense</td> </tr> <tr> <td>$0.20 < \Phi \leq 0.40$</td> <td>5</td> </tr> <tr> <td>$0.40 < \Phi$</td> <td>0</td> </tr> </tbody> </table> * Densely spaced: No more than two spots within 3mm	Size(mm)	Acceptable Q'ty	$\Phi \leq 0.20$	Accept no dense	$0.20 < \Phi \leq 0.40$	5	$0.40 < \Phi$	0	2.5					
Size(mm)	Acceptable Q'ty															
$\Phi \leq 0.20$	Accept no dense															
$0.20 < \Phi \leq 0.40$	5															
$0.40 < \Phi$	0															
03	LCD and Touch Panel black spots, white spots, contamination (non – display)	3.1 Round type: As following drawing $\Phi = (X+Y) / 2$  <table border="1" data-bbox="817 1120 1348 1283"> <thead> <tr> <th>Size(mm)</th> <th>Acceptable Q'ty</th> </tr> </thead> <tbody> <tr> <td>$\Phi \leq 0.30$</td> <td>Accept no dense</td> </tr> <tr> <td>$0.30 < \Phi \leq 0.50$</td> <td>5</td> </tr> <tr> <td>$0.50 < \Phi$</td> <td>0</td> </tr> </tbody> </table> * Densely spaced: No more than two spots within 3mm.	Size(mm)	Acceptable Q'ty	$\Phi \leq 0.30$	Accept no dense	$0.30 < \Phi \leq 0.50$	5	$0.50 < \Phi$	0	2.5					
		Size(mm)	Acceptable Q'ty													
$\Phi \leq 0.30$	Accept no dense															
$0.30 < \Phi \leq 0.50$	5															
$0.50 < \Phi$	0															
3.2 Line type: (As following drawing)  <table border="1" data-bbox="721 1478 1348 1814"> <thead> <tr> <th>Length(mm)</th> <th>Width(mm)</th> <th>Acceptable Q'ty</th> </tr> </thead> <tbody> <tr> <td>$L \leq 10$</td> <td>$W \leq 0.1$</td> <td>Accept no dense</td> </tr> <tr> <td>$L \leq 10.0$</td> <td>$0.1 < W \leq 0.25$</td> <td>4</td> </tr> <tr> <td>$L > 10$</td> <td>----</td> <td>Rejection</td> </tr> <tr> <td>----</td> <td>$0.25 < W$</td> <td>Rejection</td> </tr> </tbody> </table> * Densely spaced: No more than two lines within 3mm.	Length(mm)	Width(mm)	Acceptable Q'ty	$L \leq 10$	$W \leq 0.1$	Accept no dense	$L \leq 10.0$	$0.1 < W \leq 0.25$	4	$L > 10$	----	Rejection	----	$0.25 < W$	Rejection	2.5
Length(mm)	Width(mm)	Acceptable Q'ty														
$L \leq 10$	$W \leq 0.1$	Accept no dense														
$L \leq 10.0$	$0.1 < W \leq 0.25$	4														
$L > 10$	----	Rejection														
----	$0.25 < W$	Rejection														

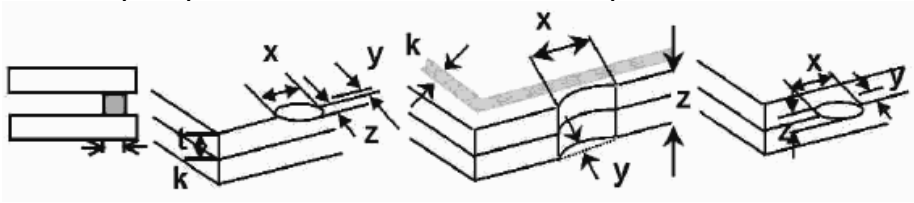
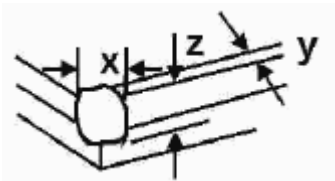
NO	Item	Criterion	AQL																		
04	Polarizer bubbles	<p>If bubbles are visible, judge using black spot specifications, not easy to find, must check in specify direction</p> <table border="1"> <thead> <tr> <th>Size Φ(mm)</th> <th>Acceptable Q'ty</th> </tr> </thead> <tbody> <tr> <td>$\Phi \leq 0.20$</td> <td>Accept no dense</td> </tr> <tr> <td>$0.20 < \Phi \leq 0.50$</td> <td>4</td> </tr> <tr> <td>$0.50 < \Phi \leq 1.00$</td> <td>3</td> </tr> <tr> <td>$1.00 < \Phi$</td> <td>0</td> </tr> <tr> <td>Total Q'ty</td> <td>4</td> </tr> </tbody> </table>	Size Φ (mm)	Acceptable Q'ty	$\Phi \leq 0.20$	Accept no dense	$0.20 < \Phi \leq 0.50$	4	$0.50 < \Phi \leq 1.00$	3	$1.00 < \Phi$	0	Total Q'ty	4	2.5						
Size Φ (mm)	Acceptable Q'ty																				
$\Phi \leq 0.20$	Accept no dense																				
$0.20 < \Phi \leq 0.50$	4																				
$0.50 < \Phi \leq 1.00$	3																				
$1.00 < \Phi$	0																				
Total Q'ty	4																				
05	Scratches	Follow NO.3 -2 Line Type.																			
06	Chipped glass	<p>Symbols: x: Chip length y: Chip width z: Chip thickness k: Seal width t: Glass thickness a: LCD side length L: Electrode pad length</p> <p>6.1 General glass chip: 6.1.1 Chip on panel surface and crack between panels:</p>  <table border="1"> <thead> <tr> <th>z: Chip thickness</th> <th>y: Chip width</th> <th>x: Chip length</th> </tr> </thead> <tbody> <tr> <td>$Z \leq 1/2t$</td> <td>Not over viewing area</td> <td>$x \leq 1/8a$</td> </tr> <tr> <td>$1/2t < z \leq 2t$</td> <td>Not exceed 1/3k</td> <td>$x \leq 1/8a$</td> </tr> </tbody> </table> <p>⊙ Unit: mm ⊙ If there are 2 or more chips, x is the total length of each chip</p> <p>6.1.2 Corner crack:</p>  <table border="1"> <thead> <tr> <th>z: Chip thickness</th> <th>y: Chip width</th> <th>x: Chip length</th> </tr> </thead> <tbody> <tr> <td>$Z \leq 1/2t$</td> <td>Not over viewing area</td> <td>$x \leq 1/8a$</td> </tr> <tr> <td>$1/2t < z \leq 2t$</td> <td>Not exceed 1/3k</td> <td>$x \leq 1/8a$</td> </tr> </tbody> </table> <p>⊙ Unit: mm ⊙ If there are 2 or more chips, x is the total length of each chip</p>	z: Chip thickness	y: Chip width	x: Chip length	$Z \leq 1/2t$	Not over viewing area	$x \leq 1/8a$	$1/2t < z \leq 2t$	Not exceed 1/3k	$x \leq 1/8a$	z: Chip thickness	y: Chip width	x: Chip length	$Z \leq 1/2t$	Not over viewing area	$x \leq 1/8a$	$1/2t < z \leq 2t$	Not exceed 1/3k	$x \leq 1/8a$	2.5
z: Chip thickness	y: Chip width	x: Chip length																			
$Z \leq 1/2t$	Not over viewing area	$x \leq 1/8a$																			
$1/2t < z \leq 2t$	Not exceed 1/3k	$x \leq 1/8a$																			
z: Chip thickness	y: Chip width	x: Chip length																			
$Z \leq 1/2t$	Not over viewing area	$x \leq 1/8a$																			
$1/2t < z \leq 2t$	Not exceed 1/3k	$x \leq 1/8a$																			

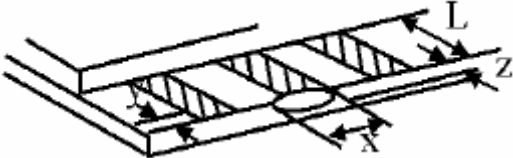
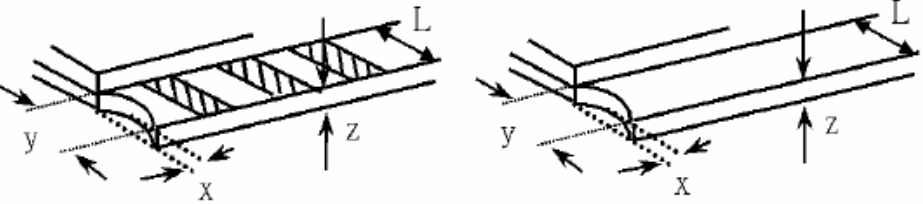
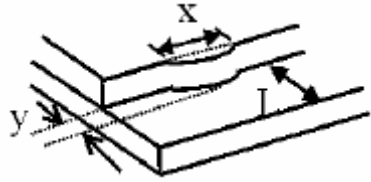
NO	Item	Criterion	AQL																
07	Glass crack	<p>Symbols: x: Chip length y: Chip width z: Chip thickness k: Seal width t: Glass thickness a: LCD side length L: Electrode pad length</p> <p>7.2 Protrusion over terminal: 7.2.1 Chip on electrode pad:</p>  <table border="1" data-bbox="544 645 1230 801"> <tr> <td>y: Chip width</td> <td>x: Chip length</td> <td>z: Chip thickness</td> </tr> <tr> <td>$y \leq 0.5\text{mm}$</td> <td>$x \leq 1/8a$</td> <td>$0 < z \leq t$</td> </tr> </table> <p>7.2.2 Non-conductive portion:</p>  <table border="1" data-bbox="544 1160 1230 1317"> <tr> <td>y: Chip width</td> <td>x: Chip length</td> <td>z: Chip thickness</td> </tr> <tr> <td>$y \leq L$</td> <td>$x \leq 1/8a$</td> <td>$0 < z \leq t$</td> </tr> </table> <p>⊙ If there chipped area touches the ITO terminal, over 2/3 of the ITO must remain and be inspected according to electrode terminal specifications. ⊙ If the product will be heat sealed by the customer, the alignment mark must not be damaged.</p> <p>7.2.3 Substrate protuberance and internal crack</p>  <table border="1" data-bbox="863 1630 1305 1787"> <tr> <td>y: width</td> <td>x: length</td> </tr> <tr> <td>$y \leq 1/3L$</td> <td>$X \leq a$</td> </tr> </table>	y: Chip width	x: Chip length	z: Chip thickness	$y \leq 0.5\text{mm}$	$x \leq 1/8a$	$0 < z \leq t$	y: Chip width	x: Chip length	z: Chip thickness	$y \leq L$	$x \leq 1/8a$	$0 < z \leq t$	y: width	x: length	$y \leq 1/3L$	$X \leq a$	2.5
y: Chip width	x: Chip length	z: Chip thickness																	
$y \leq 0.5\text{mm}$	$x \leq 1/8a$	$0 < z \leq t$																	
y: Chip width	x: Chip length	z: Chip thickness																	
$y \leq L$	$x \leq 1/8a$	$0 < z \leq t$																	
y: width	x: length																		
$y \leq 1/3L$	$X \leq a$																		

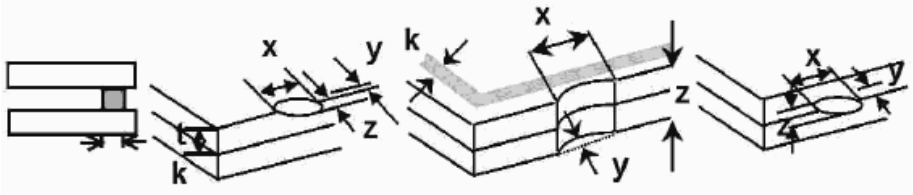
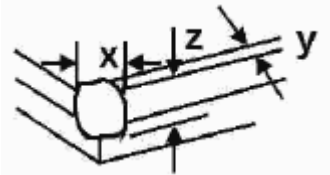

NO	Item	Criterion	AQL
08	Cracked glass	The LCD with extensive crack is not acceptable.	2.5
09	Backlight elements	9.1 Illumination source flickers when lit. 9.2 Spots or scratches that appear when lit must be judged. Using LCD spot, lines and contamination standards. 9.3 Backlight doesn't light or color is wrong.	2.5 2.5 0.65
10	Bezel	Bezel must comply with product specifications.	2.5
11	PCB、COB	11.1 COB seal may not have pinholes larger than 0.2mm or contamination. 11.2 COB seal surface may not have pinholes through to the IC. 11.3 The height of the COB should not exceed the height indicated in the assembly diagram. 11.4 There may not be more than 2mm of sealant outside the seal area on PCB. And there should be no more than three places. 11.5 Parts on PCB must be the same as on the production characteristic chart, There should be no wrong parts, missing parts or excess parts. 11.6 The jumper on the PCB should conform to the product characteristic chart.	2.5 2.5 2.5 2.5 0.65 0.65
12	FPC	12.1 FPC terminal damage \leq 1/2 FPC terminal width and can not affect the function , we judge accept. 12.2 FPC alignment hole damage \leq 1/2 alignment area and can not affect the function , we judge accept.	2.5 2.5
13	Soldering	13.1 No cold solder joints, missing solder connections, oxidation or icicle. 13.2 No short circuits in components on PCB or FPC.	2.5 0.65

NO	Item	Criterion	AQL												
14	Touch Panel Chipped glass	<p>Symbols: x: Chip length y: Chip width z: Chip thickness k: Seal width t: Touch Panel Total thickness a: LCD side length L: Electrode pad length</p> <p>14.1 General glass chip: 14.1.1 Chip on panel surface and crack between panels:</p>  <table border="1" data-bbox="400 763 1220 981"> <tr> <td>z: Chip thickness</td> <td>y: Chip width</td> <td>x: Chip length</td> </tr> <tr> <td>$Z \leq t$</td> <td>$\leq 1/2 k$ and not over viewing area</td> <td>$x \leq 1/8a$</td> </tr> </table> <p>⊙ Unit: mm ⊙ If there are 2 or more chips, x is the total length of each chip</p> <p>14.1.2 Corner crack:</p>  <table border="1" data-bbox="400 1359 1220 1576"> <tr> <td>z: Chip thickness</td> <td>y: Chip width</td> <td>x: Chip length</td> </tr> <tr> <td>$z \leq t$</td> <td>$\leq 1/2 k$ and not over viewing area</td> <td>$x \leq 1/8a$</td> </tr> </table> <p>⊙ Unit: mm ⊙ If there are 2 or more chips, x is the total length of each chip</p>	z: Chip thickness	y: Chip width	x: Chip length	$Z \leq t$	$\leq 1/2 k$ and not over viewing area	$x \leq 1/8a$	z: Chip thickness	y: Chip width	x: Chip length	$z \leq t$	$\leq 1/2 k$ and not over viewing area	$x \leq 1/8a$	2.5
z: Chip thickness	y: Chip width	x: Chip length													
$Z \leq t$	$\leq 1/2 k$ and not over viewing area	$x \leq 1/8a$													
z: Chip thickness	y: Chip width	x: Chip length													
$z \leq t$	$\leq 1/2 k$ and not over viewing area	$x \leq 1/8a$													

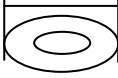
NO	Item	Criterion	AQL						
15	Touch Panel(Fish eye)	<table border="1"> <thead> <tr> <th>SIZE(mm)</th> <th>Acceptable Q'ty</th> </tr> </thead> <tbody> <tr> <td>$L \leq 0.7$</td> <td>Accept no dense</td> </tr> <tr> <td>$L > 0.7\text{mm}$</td> <td>0</td> </tr> </tbody> </table>	SIZE(mm)	Acceptable Q'ty	$L \leq 0.7$	Accept no dense	$L > 0.7\text{mm}$	0	2.5 
		SIZE(mm)	Acceptable Q'ty						
		$L \leq 0.7$	Accept no dense						
$L > 0.7\text{mm}$	0								
16	Touch Panel Newton ring	Newton ring dimension $\leq 1/2$ touch panel area and not affect font and line distortion($\leq 2.5\%$), it is acceptable.	2.5						
17	Touch Panel Linearity	Less than 2.5% is acceptable.	2.5						
18	LCD Ripple	Touch the touch panel, can not see the LCD ripple. Pen: R 1.0mm silicon rubber. Operation Force: 80g	2.5						
19	General appearance	19.1 Pin type must match type in specification sheet.	0.65						
		19.2 LCD pin loose or missing pins.	0.65						
		19.3 Product packaging must the same as specified on packaging specification sheet.	0.65						
		19.4 Product dimension and structure must conform to product specification sheet.	0.65						



13. Handling Precaution:

13-1 Handling of LCM

- Don't give external shock.
- Don't apply excessive force on the surface.
- Liquid in LCD is hazardous substance. Must not lick and swallow. when the liquid is attach to your hand, skin, cloth etc. Wash it out thoroughly and immediately.
- Don't operate it above the absolute maximum rating.
- Don't disassemble the LCM.
- The operators should be grounded whenever he/she comes into contact with the module. Never touch any of the conductive parts such as the LSI pads, the copper leads on the PCB and the interface terminals with any parts of the human body.
- The modules should be kept in antistatic bags or other containers resistant to static for storage.
- The module is coated with a film to protect the display surface. Be care when peeling off this protective film since static electricity may be generated.

13-2 Storage

- Store in an ambient temperature of $25\pm 10^{\circ}\text{C}$, and in a relative humidity of $50\pm 10\%\text{RH}$. Don't expose to sunlight or fluorescent light.
- Storage in a clean environment, free from dust, active gas, and solvent.
- Store in anti-static electricity container.
- Store without any physical load.

13-3 Soldering

- Use only soldering irons with proper grounding and no leakage.
- Iron: No higher than $280\pm 10^{\circ}\text{C}$ and less than 3 sec during Hand soldering.
- Rewiring: no more than 2 times.

14. Guarantee:

Our products meet requirements of the environment.

YEEBO ROHS requirement is based on European Union Directive 2011/65/EU (ROHS) Requirements and Update.