

▪ Description

The YB1210R is a series of ultra-low-noise, low dropout (LDO) linear regulators with 2.0% output voltage accuracy. The YB1210R regulators achieve a low 320mV dropout at 300mA load current of 3.3V output and are available in voltages ranging from 1.2V to 3.6V with 0.1 V per step (custom voltage is considerable at request).

The YB1210R regulators are optimized to work with low-ESR and low cost ceramic capacitors, reducing the amount of board space critical in portable devices. The YB1210R requires only 1.0 μ F output capacitor for stability with any load and consumes less than 1 μ A in shutdown mode.

Built-in thermal shutdown and short-circuit protect offer secure protection against fault operation. The YB1210R regulators are available in SOT-23 / SOT-25 / SOT-89 packages.

▪ Features

- High Accuracy Output Voltage : $\pm 2\%$
- Wide Output Voltage Range : 1.2 ~ 3.6V
- Ultra-Low-Noise Low-Drop-Out
- Typical Output Current : 300 mA
- Low Quiescent Current: $\sim 60\mu\text{A}$
- 320mV Dropout at 300mA 3.3V Output
- Stable with 1.0 μ F Ceramic Capacitor
- Only Need Input and Output Capacitors
- Thermal Protection Shutdown
- Output Short-Circuit Current Limit
- Built-In Internal Soft-Start
- Green Package (RoHS) Available

▪ Applications

- PDA, Notebook, PC Computers
- DSC, Handset Camera Modules
- PCMCIA Cards, PC Cameras
- USB Based Portable Devices
- GSM/GPRS/3G RF Transceiver
- Wireless LANs
- Bluetooth Portable Radios
- Battery-Powered Devices

Typical Application Circuit

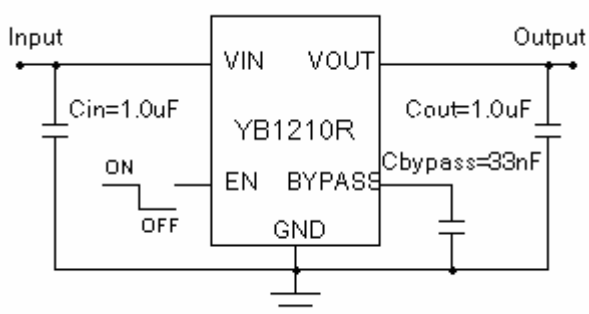

Figure 1-1: SOT-25 Application Circuit

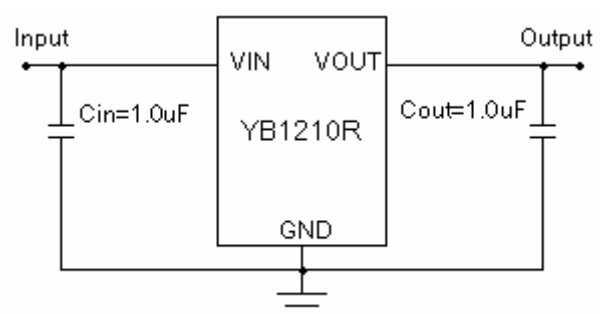

Figure 1-2: SOT-23/SOT-89 Application Circuit

Pin Configuration

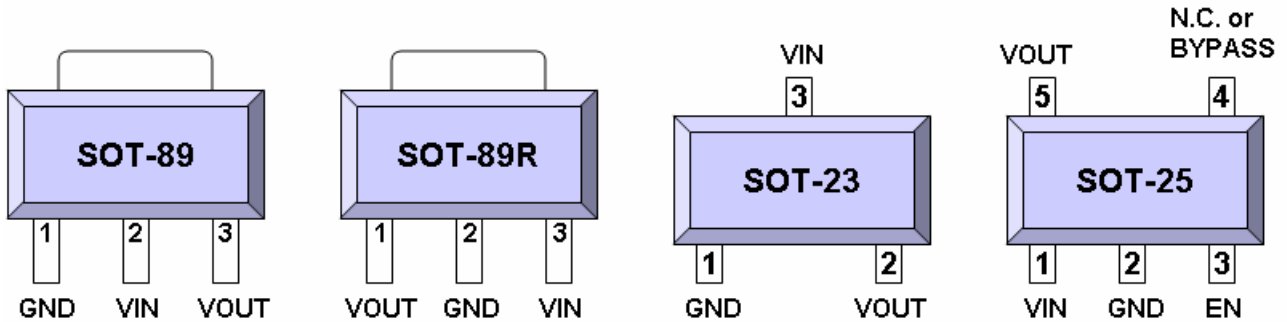

Figure 2: Pin Configuration

Pin Description

Table 1

Name	Description
VIN	Unregulated input supply. Bypass with a capacitor to GND.
GND	Ground pin.
EN	Pull high to enable the regulator.
N.C. or BYPASS	Connect a 33nF capacitor to GND for low noise operation or N.C.
VOUT	Regulated output voltage. Bypass with a capacitor to GND.

Electrical Characteristics

Table 2 $V_{IN} = (V_{OUT} + 1V)$, $C_{IN} = C_{OUT} = 1.0\mu F$, $V_{EN} = V_{IN}$, $T_A = 25^\circ C$, unless otherwise noted.

Description	Symbol	Test Conditions	MIN	TYP	MAX	Units
Input Voltage Range	V_{IN}		2.0		5.5	V
Output Voltage	V_{OUT}	Predefined	1.2		3.6	V
Output Voltage Accuracy	ΔV_{OUT}	$I_{OUT} = 10mA, V_{OUT} \geq 1.3V$	-2.0		+2.0	%
		$I_{OUT} = 10mA, V_{OUT} = 1.2V$	0		+4.0	
Output Current Limit	I_{SC}	Short-Circuit Output		200		mA
Dropout Voltage (Note 1)	V_{DROP}	$V_{OUT} = 3.6V, I_{OUT} = 300mA$		300		mV
		$V_{OUT} = 3.0V, I_{OUT} = 300mA$		350		
		$V_{OUT} = 2.5V, I_{OUT} = 300mA$		450		
		$V_{OUT} = 1.5V, I_{OUT} = 300mA$		700		
		$V_{OUT} = 1.2V, I_{OUT} = 300mA$		870		
Ground Current	I_G	$I_{ground} = I_{IN} - I_{OUT}$		60		μA
Line Regulation	ΔV_{LINE}	$V_{IN} = (V_{OUT} + 1V)$ to 5.5V, $I_{OUT} = 10mA$		0.3	0.4	%/V
Load Regulation	ΔV_{LOAD}	$I_{OUT} = 1mA$ to 300mA		1.0	1.5	%
Shutdown Supply Current	I_{SD}	EN = 0V			1	μA
Ripple Rejection (PSRR)	PSRR	f = 1KHz, $I_{OUT} = 1mA$		50		dB
		f = 10KHz, $I_{OUT} = 1mA$		60		
		f = 100KHz, $I_{OUT} = 1mA$		40		
Start Up Delay (Note 2)		Rload = 100 ohm, Cbypass = 0nF		20	50	μs
		Rload = 100 ohm, Cbypass = 33nF		2	3.5	ms
Shutdown Delay (Note 3)		Rload = 10K ohm, $V_{OUT} = 1.5V$		1		ms
		Rload = 10K ohm, $V_{OUT} = 1.2V$		1		
EN Logic Low Level	V_{IL}	$V_{IN} = 2.0V$ to 5.5V			0.4	V
EN Logic High Level	V_{IH}	$V_{IN} = 2.0V$ to 5.5V	1.2		V_{IN}	V
EN Input Bias Current	I_{BEN}	$V_{IN} = EN = V_{OUT} + 1V$		0.01		μA
Thermal Shutdown	T_{SD}	Shutdown Temperature		160		$^\circ C$
Thermal Hysteresis	T_{HYS}			20		$^\circ C$

Note :

1. The drop out voltage varies depending on output voltage selection. Dropout is defined as $V_{IN} - V_{OUT}$ when V_{OUT} is 100mV below nominal V_{OUT} where $V_{IN} = V_{OUT} + 1V$ for nominal V_{OUT} .
2. Time needed for V_{OUT} to reach 90% of final value.
3. Time needed for V_{OUT} to discharge below 0.5V.

Typical Performance Characteristics

$V_{IN} = (V_{OUT} + 1V)$, $C_{IN} = C_{OUT} = 1.0\mu F$, $V_{EN} = V_{IN}$, $T_A = 25^\circ C$, unless otherwise noted.

Dropout Voltage vs. Output Load

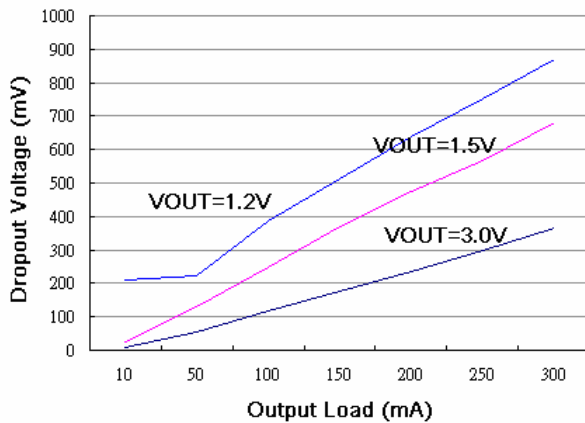

Ground Current vs. Input Voltage

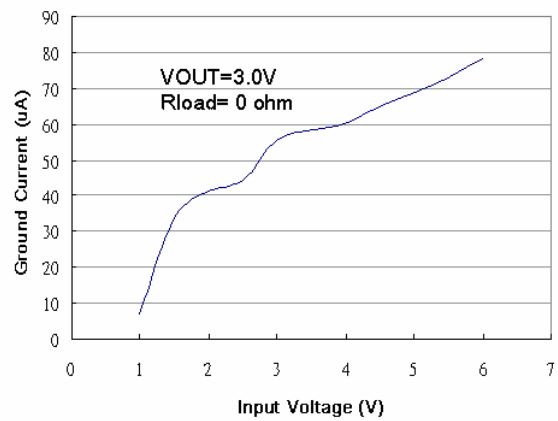

Dropout Voltage vs. Temperature

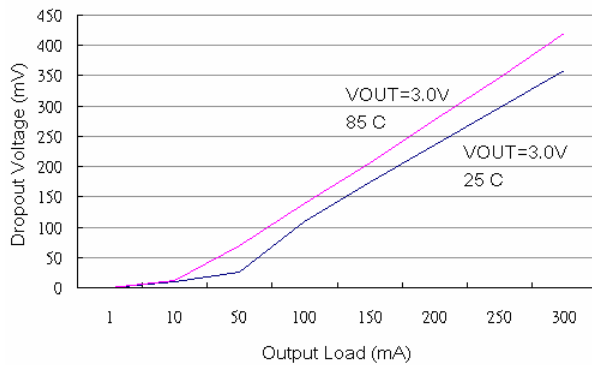

Dropout Voltage vs. Temperature

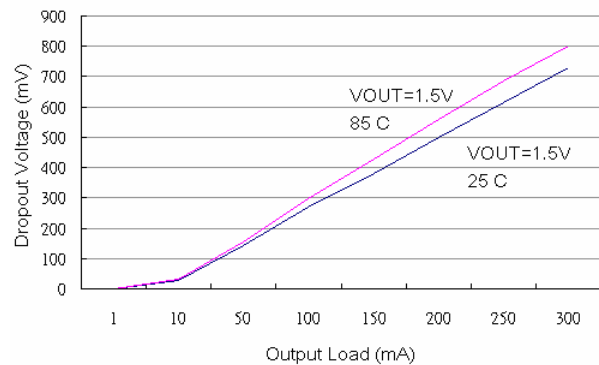

Output Voltage vs. Temperature

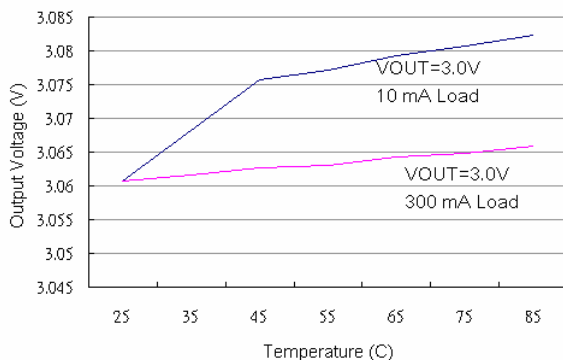

Output Voltage vs. Temperature

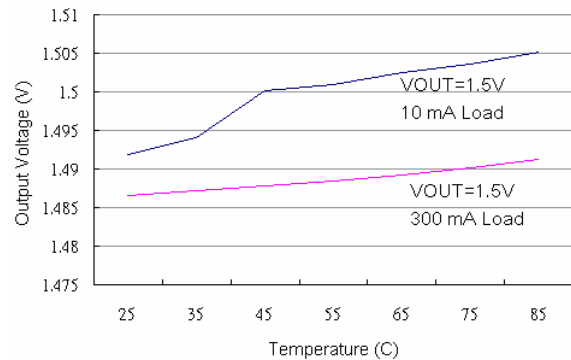

Load Transient Response

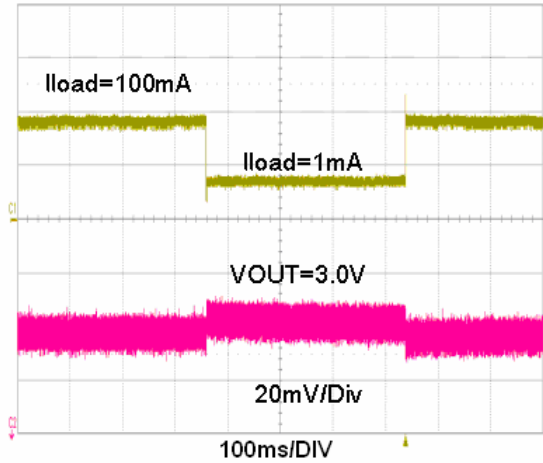

Line Transient Response

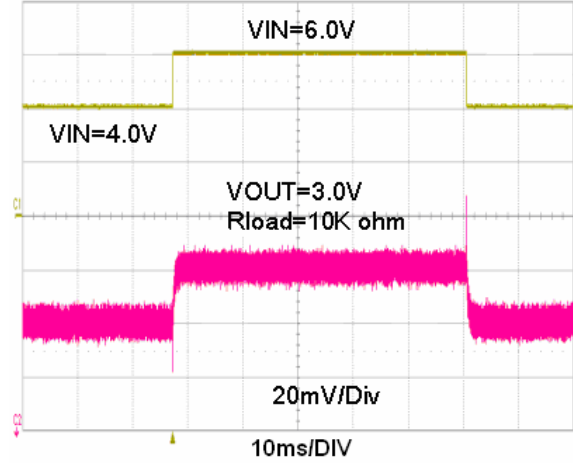

Start Up Delay (C_{bypass}=0nF)

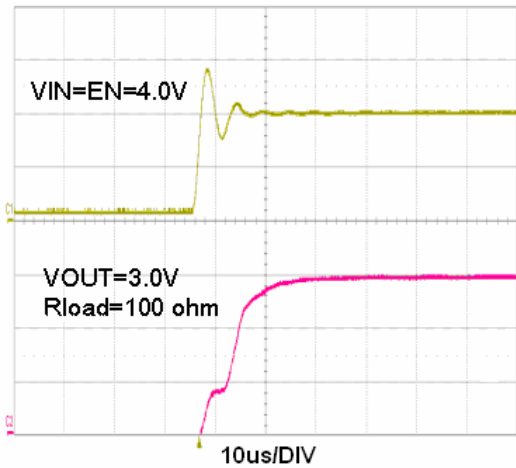

Start Up Delay (C_{bypass}=33nF)

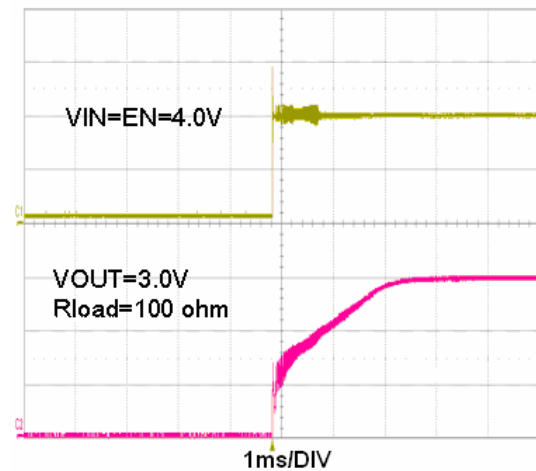

Shutdown Delay (V_{OUT}=1.2V)

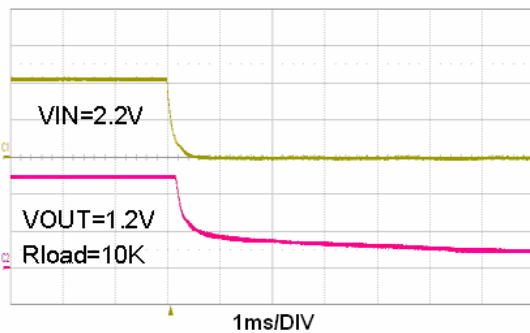

Shutdown Delay (V_{OUT}=1.5V)

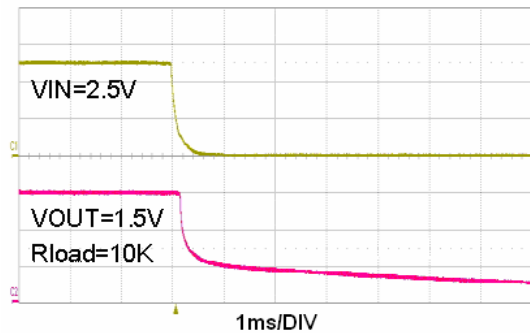

PSRR vs. Frequency (1mA load)

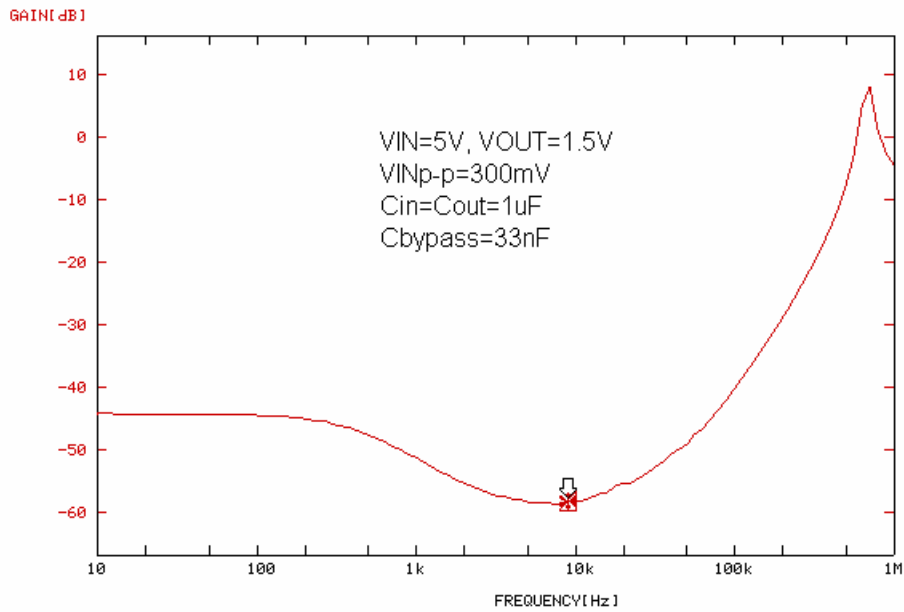

PSRR vs. Frequency (10mA load)

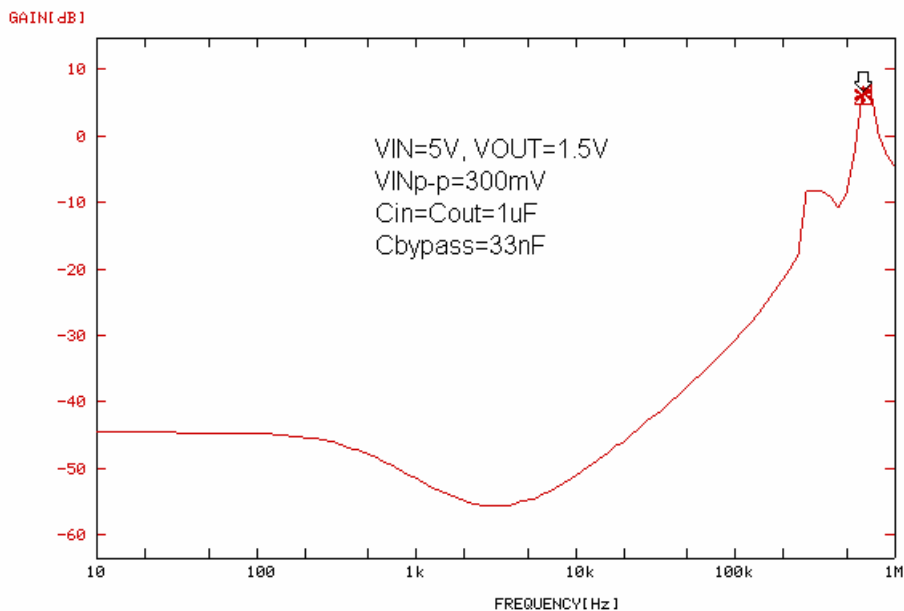

Function Block

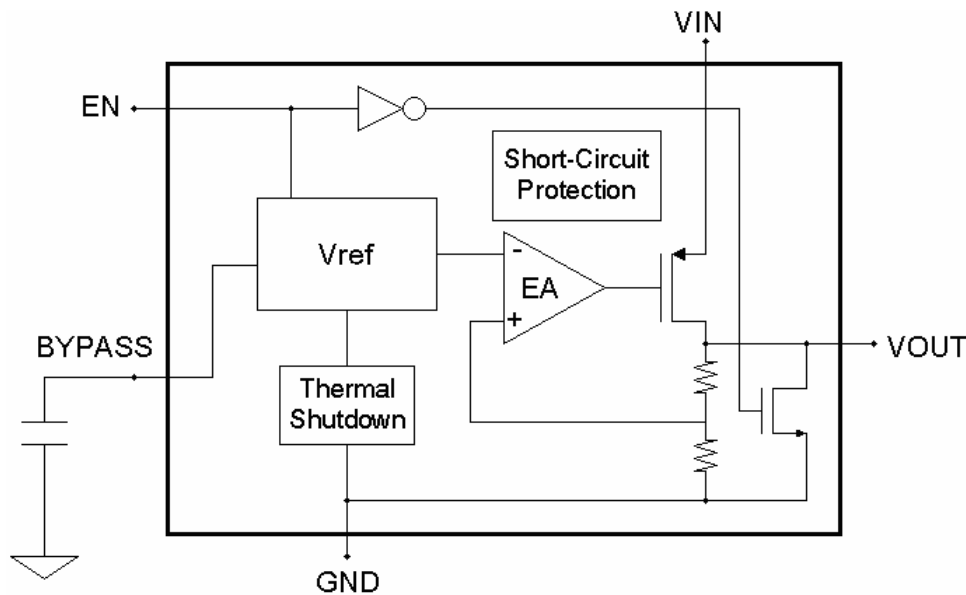

Figure 3: Function Block

Functional Description

The YB1210R is an ultra-low-noise, low-quiescent current, low-dropout linear regulator. It is supplied in a SOT-23 / SOT-25 / SOT-89 package for different applications. YB1210R can supply loads up to 300mA (typical operation, not maximum) and output voltages are preset and ranging from 1.2V to 3.6V.

As shown in the *Functional Block Diagram*, the YB1210R consists of a reference and noise bypass circuit, error amplifier, output drive transistor, internal feedback voltage divider, thermal sensor, and short circuit current limiter.

The internal reference is connected to the error amplifier's inverting input. The error amplifier compares this reference with the

feedback voltage and amplifies the difference. If the feedback voltage is lower than the reference voltage, the gate of the pass-transistor is pulled low. This allows more current to pass to the output and increases the output voltage. If the feedback voltage is too high, the gate of the pass transistor is pulled high, allowing less current to pass to the output.

Stability

The YB1210R is a high performance LDO emphasizing stability with low output capacitance. It is able to maintain stability with an output capacitor as low as 1.0 μ F. The output capacitor can also be increased to optimize performance. The YB1210R will remain stable and in regulation with no load, unlike many other voltage regulators.

Internal P-Channel Pass Transistor

The YB1210R features a low impedance P-channel MOSFET pass transistor. This provides several advantages over similar designs using a PNP pass transistor, including low operating power and longer battery life. The YB1210R consumes only 60 μ A of quiescent current under most conditions.

Output Short-Circuit Current Limit

The YB1210R includes a current limiter, which monitors and controls the pass transistor's gate voltage, limiting the output current to about 200mA, for example, in a short-circuit output situation.

Shutdown

The YB1210R also features a low-power active shutdown mode. It has a switch that turns off the device when disabled. This allows the output capacitor and load to discharge and de-energize the load. In the shutdown mode, the internal functional blocks, such as voltage reference and the error amplifier, are turned off completely, and the quiescent current is less than 1 μ A.

Thermal Protection Shutdown

The thermal protection shutdown function protects the device from operating in over temperature condition. When the junction temperature exceeds +160 $^{\circ}$ C, the thermal sensor signals the shutdown logic, turning off the pass transistor and allowing the IC to cool down. The thermal sensor turns the pass transistor on again after the IC's junction temperature drops to +140 $^{\circ}$ C.

Auto-Discharge Circuitry

The YB1210R deploys a NMOS connecting

between V_{OUT} and ground. When EN pin is pulled low, the NMOS is activated by an inverted signal from EN. The charge kept on output capacitor is discharged quickly through the NMOS. It prevents the system from abnormal operation at the beginning of shutdown mode.

Soft-Start Circuitry

The YB1210R includes a soft-start circuitry to limit inrush current at turn-on. During power up, the output capacitor and output load are charged with a reduced output current. Shortly after the initial power up, the soft-start feature is terminated and normal operation is resumed.

Application Information**Enable/Shutdown**

The YB1210R comes with an active-high enable pin that allows the regulator to be enabled. Forcing the enable pin low disables the regulator and puts it into the shutdown mode. This pin cannot be left floating as it may cause an undetermined state.

Input/Output Capacitor

It is recommended to use a 1.0 μ F capacitor on the YB1210R input and a 1.0 μ F capacitor on the output. For high regulation performance, larger input capacitor values and lower ESRs provide better noise rejection and line-transient response. The output noise, load-transient response, stability, and power-supply rejection can be improved by using large output capacitors. Low ESR ceramic capacitors provide optimal performance and save space.

Package Information (SOT-23)

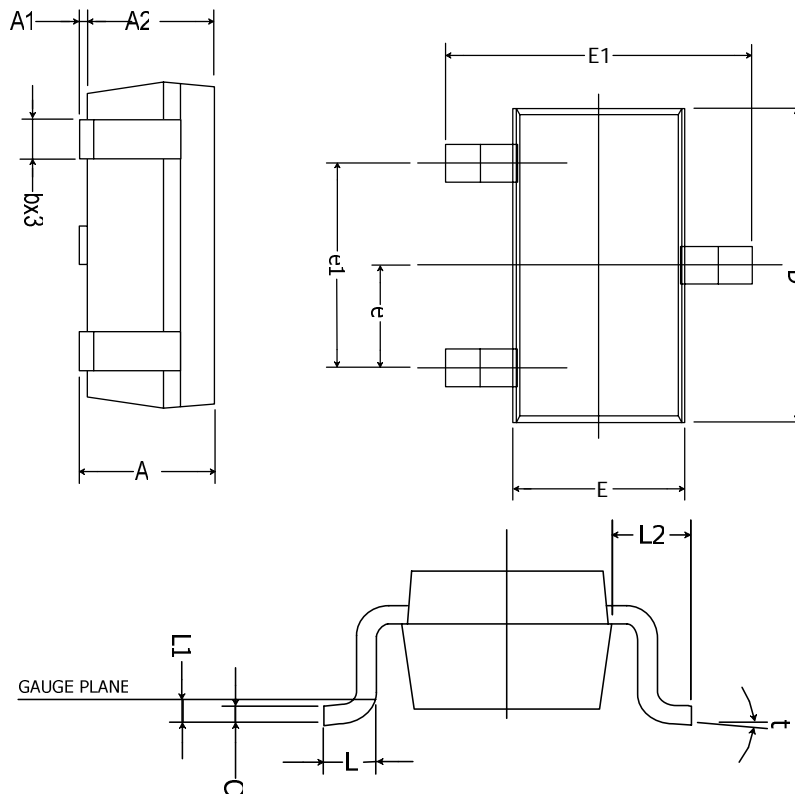

Symbol	millimeters		Inches	
	MIN.	MAX.	MIN.	MAX.
A	0.95	1.45	.037	.057
A1	0.05	0.15	.002	.006
A2	0.90	1.30	.035	.051
b	0.30	0.50	.0118	.019
C	0.08	0.20	.0031	.0078
D	2.84	3.00	.1118	.118
E	1.50	1.70	.059	.0669
E1	2.60	3.00	.102	.118
e	0.95 BSC.		.0374 BSC.	
e1	1.90 BSC.		.0748 BSC.	
L	0.35	0.55	.0137	.0216
L1	0.10 BSC.		.0039 BSC.	
L2	0.60 REF.		.0236 REF.	
t	0°	8°	0°	8°

Package Information (SOT-25)

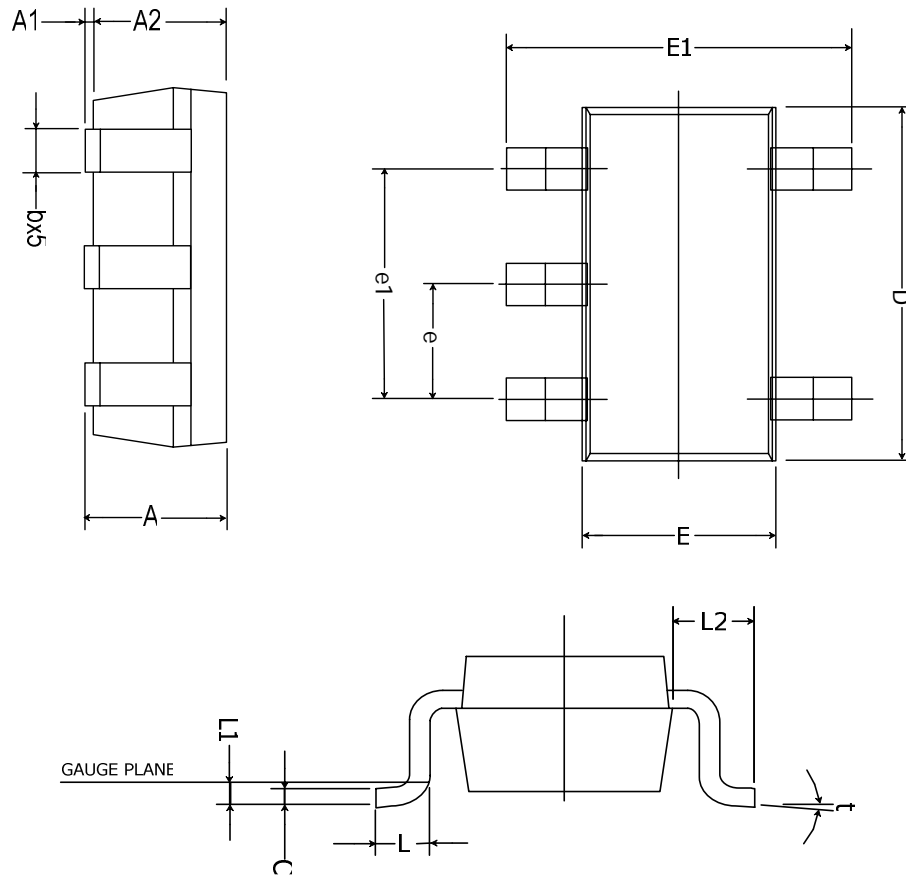

Symbol	millimeters		Inches	
	MIN.	MAX.	MIN.	MAX.
A	0.95	1.45	.037	.057
A1	0.05	0.15	.002	.006
A2	0.90	1.30	.035	.051
b	0.30	0.50	.0118	.019
C	0.08	0.20	.0031	.0078
D	2.84	3.00	.1118	.118
E	1.50	1.70	.059	.0669
E1	2.60	3.00	.102	.118
e	0.95 BSC.		.0374 BSC.	
e1	1.90 BSC.		.0748 BSC.	
L	0.35	0.55	.0137	.0216
L1	0.10 BSC.		.0039 BSC.	
L2	0.60 REF.		.0236 REF.	
t	0°	8°	0°	8°

Package Information (SOT-89)

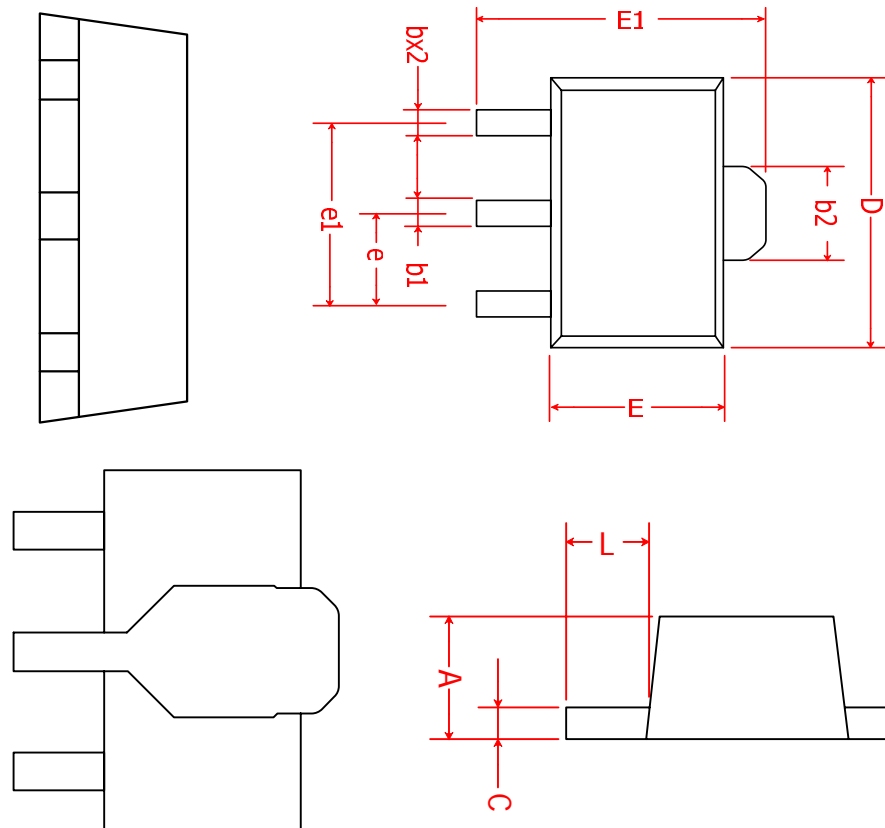

Symbol	millimeters		Inches	
	MIN.	MAX.	MIN.	MAX.
A	1.40	1.60	.055	.063
b	0.36	0.48	.014	.019
b1	0.44	0.56	.017	.022
b2	1.50	1.83	.059	.072
C	0.35	0.44	.014	.017
D	4.40	4.60	.173	.181
E	2.29	2.60	.090	.102
E1	3.94	4.25	.155	.167
e	1.50 BSC.		.059 BSC.	
e1	3.00 BSC.		.118 BSC.	
L	0.89	1.20	.035	.047

NOTICE:

- The information described herein is subject to change without notice.
- Yobon does not assume any responsibility for use of any circuitry or applications described herein, nor does it convey any patent license.