

## DUAL CHANNEL POWER AMPLIFIER——YD2822

### DESCRIPTION

The YD2822 is a monolithic integrated audio amplifier in a 8-pin plastic dual in line package. It is designed for portable cassette players and radios.

### FEATURES

- \*Wide operating supply voltage : $V_{CC}=1.8V\sim 15V$
- \*Low crossover distortion
- \*Low quiescent circuit current
- \*Bridge/stereo configuration

### BLOCK DIAGRAM

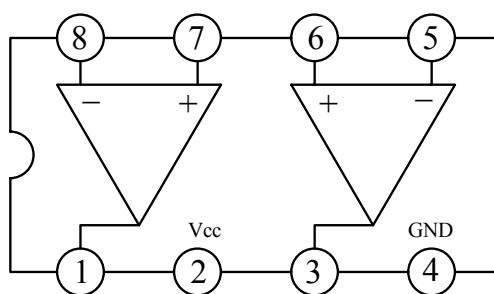

### ABSOLUTE MAXIMUM RATINGS (Tamb=25°C)

PARAMETER		SYMBOL	VALUE	UNIT
Supply Voltage		V <sub>cc</sub>	15	V
Output Peak Current		I <sub>op</sub>	1.0	A
Power Dissipation	T <sub>amb</sub> =50°C	P <sub>D</sub>	1.0	W
	T <sub>case</sub> =50°C		1.4	
Operating Temperature		T <sub>opr</sub>	-20~+ 70	°C
Storage Temperature		T <sub>stg</sub>	-40~+150	°C

### WuXi YouDa Electronics Co., Ltd

Add: No.5 Xijin Road, National Hi-Tech Industrial Development Zone, Wuxi Jiangsu China

Tel: 86-510-85205117 86-510-85205106 Fax: 86-510-85205110 Website: www.e-youda.com

SHENZHEN OFFICE Tel: 86-755-83740369 Fax: 86-755-83741418

## ELECTRICAL CHARACTERISTICS

(V<sub>CC</sub>=6V, T<sub>amb</sub>=25°C, all voltage referenced to GND, Unless otherwise specified)

## STEREO APPLICATION

PARAMETER	SYMBOL	TEST CONDITIONS		MIN	TYP	MAX	UNIT	
Operating Supply Voltage	V <sub>CC</sub>			1.8		15	V	
Quiescent Circuit Output Voltage	V <sub>O</sub>				2.7		V	
		V <sub>CC</sub> =3V			1.2		V	
Input Bias Current	I <sub>B</sub>				100		nA	
Quiescent Circuit Current	I <sub>ccq</sub>				6	9	mA	
Output Power	P <sub>O</sub>	f=1kHz THD=10%	R <sub>L</sub> =32Ω	V <sub>CC</sub> =9V		300		mW
				V <sub>CC</sub> =6V	90	120		
				V <sub>CC</sub> =4.5V		60		
				V <sub>CC</sub> =3V	15	20		
				V <sub>CC</sub> =2V		5		
			R <sub>L</sub> =16Ω	V <sub>CC</sub> =6V	170	220		
				V <sub>CC</sub> =9V		1000		
				V <sub>CC</sub> =6V	300	380		
			R <sub>L</sub> =8Ω	V <sub>CC</sub> =6V	450	650		
				V <sub>CC</sub> =4.5V		320		
R <sub>L</sub> =4Ω	V <sub>CC</sub> =4.5V		320					
	V <sub>CC</sub> =3V		110					
Total Harmonic Distortion	THD	R <sub>L</sub> =32Ω, P <sub>O</sub> =40mW			0.2		%	
		R <sub>L</sub> =16Ω, P <sub>O</sub> =75mW			0.2			
		R <sub>L</sub> =8Ω, P <sub>O</sub> =150mW			0.2			
Closed Loop Voltage Gain	G <sub>V</sub>	f=1kHz		37	39	41	dB	
Channel Balance	ΔG <sub>V</sub>					±1	dB	
Input Resistance	Z <sub>i</sub>	f=1kHz		100			kΩ	
Input Noise Voltage	V <sub>NI</sub>	R <sub>g</sub> =10kΩ BPF=20Hz~20kHz			2.5		μV	
Ripple Rejection	RR	f=100Hz C <sub>1</sub> =C <sub>2</sub> =100μF		24	30		dB	
Cross Talk	CT	f=1kHz			30		dB	

## YOU DA INTEGRATED CIRCUIT

YD2822

## BTL APPLICATION

PARAMETER	SYMBOL	TEST CONDITIONS		NIN	TYP	MAX	UNIT	
Operating Supply Voltage	$V_{CC}$			1.8		15	V	
Quiescent Circuit Current	$I_{ccq}$	$R_L = \infty$			6	9	mW	
DC Output Balance	$\Delta V_O$	$R_L = 8 \Omega$				$\pm 50$	mW	
Input Bias Current	$I_B$				100		nA	
Output Power	$P_o$	$f=1\text{kHz}$ THD =10%	$R_L=32 \Omega$	$V_{CC}=9\text{V}$		1000		mW
				$V_{CC}=6\text{V}$	300	320		
				$V_{CC}=4.5\text{V}$		200		
				$V_{CC}=3\text{V}$	50	65		
				$V_{CC}=2\text{V}$		8		
			$R_L=16 \Omega$	$V_{CC}=9\text{V}$		2000		
				$V_{CC}=6\text{V}$				
				$V_{CC}=3\text{V}$		120		
			$R_L=8 \Omega$	$V_{CC}=6\text{V}$	900	1350		
				$V_{CC}=4.4\text{V}$		700		
				$V_{CC}=3\text{V}$		220		
			$R_L=4 \Omega$	$V_{CC}=4.5\text{V}$		1000		
$V_{CC}=3\text{V}$	200	350						
$V_{CC}=2\text{V}$		80						
Total Harmonic Distortion	THD	$P_o=0.5\text{W}, R_L=8 \Omega, f=1\text{kHz}$			0.2		%	
Closed Loop Voltage Gain	$G_V$	$f=1\text{kHz}$		37	39	41	dB	
Input Resistance	$Z_i$	$f=1\text{kHz}$		100			k $\Omega$	
Input Noise Voltage	$V_{N1}$	$R_g=10\text{k}\Omega$ BPF=20Hz~20kHz			3		$\mu\text{V}$	
Ripple Rejection	RR	$f=100\text{Hz}$			40		dB	
Power Bandwidth	BW	$R_L=8 \Omega, P_o=1\text{W}$			120		kHz	

## APPLICATION CIRCUIT

## (1) YD2822 STEREO APPLICATION

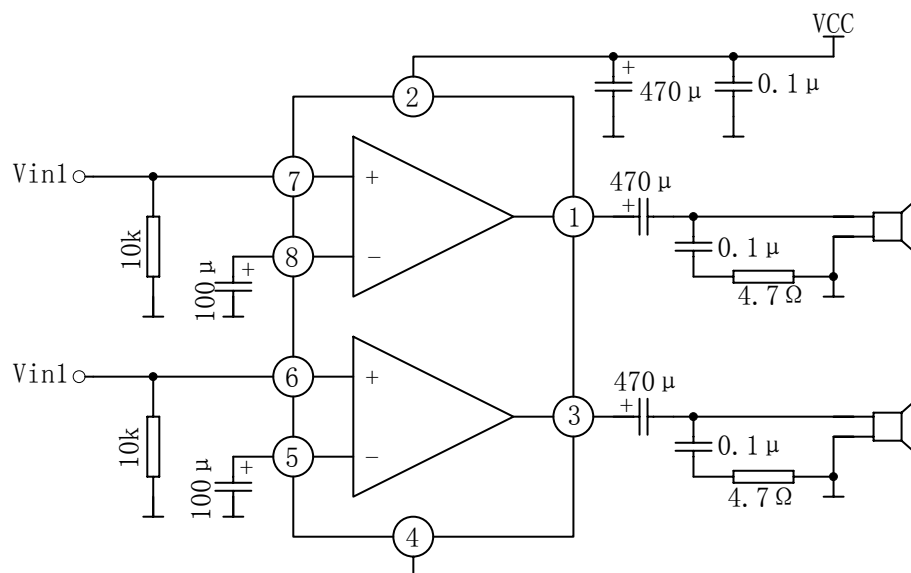

## (2) YD2822 BTL APPLICATION

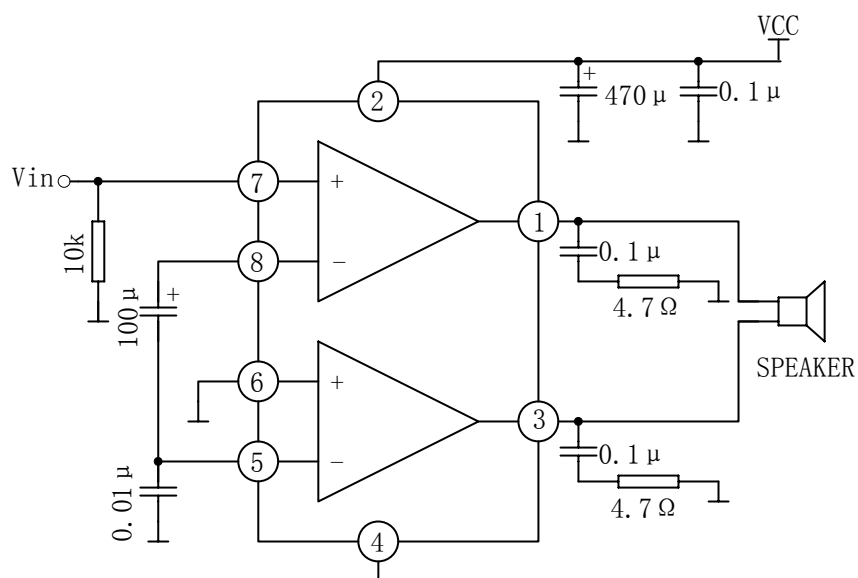

OUTLINE DRAWING

DIP-8

unit:mm

