

LOW POWER AUDIO AMPLIFIER—YD34119

DESCRIPTION

The YD34119 is a low power audio amplifier integrated circuit intended (primarily) for the telephone applications, such as in speakerphones.

FEATURES

- *Wide operating supply voltage: $V_{CC}=2\sim 16V$;
- *Low quiescent supply current ($I_{CC}=2.7mA$, typ.);
- *Medium output power
 $P_o=250mW$ at $V_{CC}=6V$, $R_L=32\ \Omega$, THD=10%;
- *Load impedance range ($8\ \Omega$ to $100\ \Omega$);
- *Low distortion;
- *Mute function ($I_{CC}=65\ \mu A$, typ.);
- *Minimum number of external parts required.

BLOCK DIAGRAM

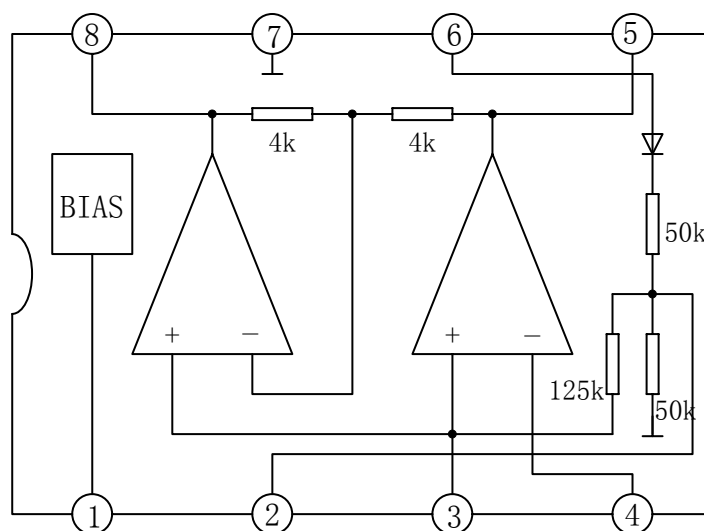

WuXi YouDa Electronics Co., Ltd

Add: No.5 Xijin Road, National Hi-Tech Industrial Development Zone, Wuxi Jiangsu China

Tel: 86-510-85205117 86-510-85205106 Fax: 86-510-85205110 Website: www.e-youda.com

SHENZHEN OFFICE Tel: 86-755-83740369 Fax: 86-755-83741418

YOUDA INTEGRATED CIRCUIT

YD34119

ABSOLUTE MAXIMUM RATINGS (Tamb=25°C)

PARAMETER	SYMBOL	VALUE	UNIT
Supply Voltage	Vcc	18	V
Peak Output Current	Iop	±250	mA
Maximum Input/Output Voltage	Vi/Vout	-1.0~Vcc+1.0	V
Junction Temperature	Tj	-55~+140	°C

RECOMMENDED OPERATION CONDITIONS (Tamb=25°C)

PARAMETER	SYMBOL	MIN	TYP	MAX	UNIT
Supply Voltage	Vcc	2.0	4.2	16	V
Load Impedance	RL	8	32	100	Ω
Peak Load Current	Iop		100	200	mA
Differential Gain(5kHz Bandwidth)	Gv	0	30	46	dB
Voltage at Mute	Vi(mute)	0		Vcc	V
Ambient Temperature	Tamb	-20		+70	°C

ELECTRICAL CHARACTERISTICS (Tamb=25°C, Vcc=6V, Unless otherwise specified)

PARAMETER	SYMBOL	TEST CONDITIONS	MIN	TYP	MAX	UNIT
Operating Current	Iccq	Vcc=3.0V, Mute=0.8V, RL=∞		2.7	4.0	mA
		Vcc=16.0, Mute=0.8V, RL=∞		3.3	5.0	mA
		Vcc=3.0V, Mute=2.0V, RL=∞		65	100	μA
Output DC Voltage	Vo	Vcc=3.0V, RL=16Ω, Rf=75kΩ,	1.0	1.15	1.25	V
		Vcc=6.0V, RL=16Ω, Rf=75kΩ,		2.65		
		Vcc=12.0V, RL=16Ω, Rf=75kΩ,		5.65		
Output Offset Voltage	ΔVo	Vcc=6.0V, Rf=75kΩ, RL=32Ω	-30	0	+30	mV
Output High Level	VOH	2.0V < Vcc < 16V, Iout=-75mA		Vcc -1.0		V
Output Low Level	VOL	2.0V < Vcc < 16V, Iout=75mA		0.16		V
Input Bias Current	IIB			-100	-200	nA
AC Input Resistance	Zi	@Vin		>30		MΩ
Equivalent Resistance	Ri	Pin4	100	150	220	kΩ
	Rf	Pin2	18	25	40	kΩ
	R1	Pin1	50		175	kΩ
Chip Disable (Pin1)Input Voltage	VI _L	Low			0.8	V
	VI _H	High	2.0			V

YOUDA INTEGRATED CIRCUIT

YD34119

PARAMETER	SYMBOL	TEST CONDITIONS	MIN	TYP	MAX	UNIT
Open Loop Gain of Amp 1	G_{vo}		80			dB
Close Loop Gain of Amp 2	G_v	$V_{cc}=6.0V, f=1.0kHz, R_L=32\Omega$	-0.35	0	0.35	dB
Output Power	P_o	$V_{cc}=3.0V, R_L=16\Omega, THD\leq 10\%$	55			mW
		$V_{cc}=6.0V, R_L=32\Omega, THD\leq 10\%$	250			
		$V_{cc}=12.0V, R_L=100\Omega, THD\leq 10\%$	400			
Total Harmonic Distortion	THD	$V_{cc}=6.0V, R_L=32\Omega, P_o=125mW$		0.5	1.0	%
		$V_{cc}\geq 3.0V, R_L=8\Omega, P_o=20mW$		0.5		
		$V_{cc}\geq 12V, R_L=32\Omega, P_o=200mW$		0.6		
Gain Bandwidth	BW			1.5		MHz
Power Supply rejection	RR ($V_{cc}=6.0V, \Delta=3.0V$)	$C1=\infty, C2=0.01\mu F$	50			dB
		$C1=0.1\mu F, C2=0, f=1.0kHz$		12		
		$C1=1.0\mu F, C2=0.01\mu F, f=1.0kHz$		52		
Muting	G_{MUT}	Mute=2.0V, $V_{cc}=6.0V, 1.0kHz < f < 20kHz,$	70			dB

APPLICATION CIRCUIT

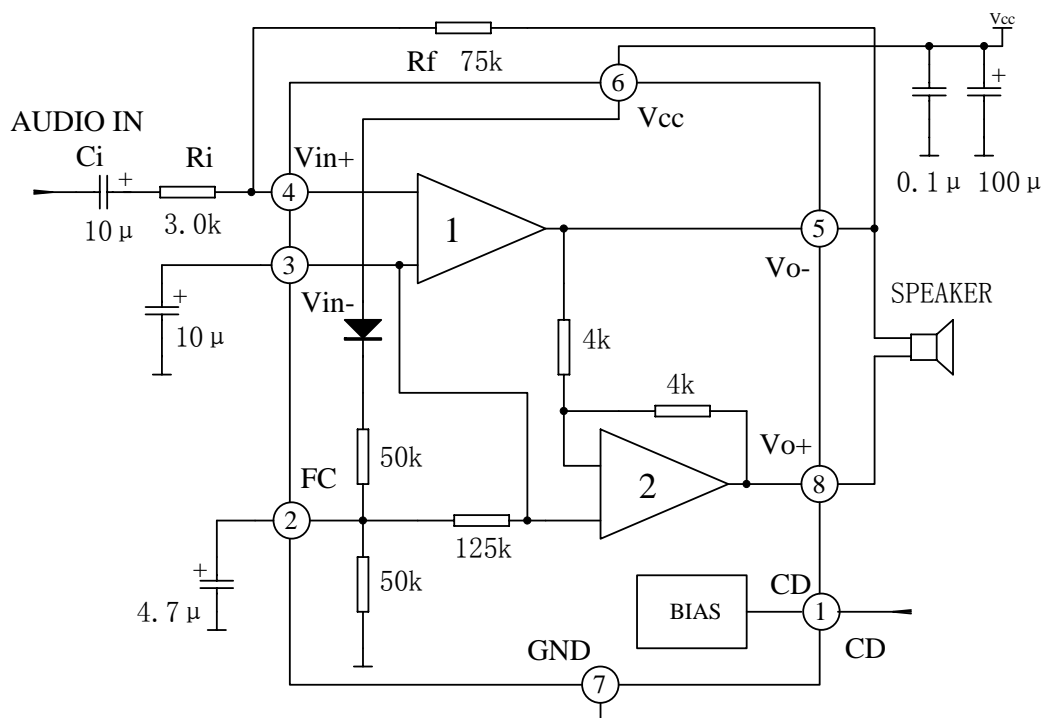

OUTLINE DRAWING

SOP-8

unit:mm

