

LOW VOLTAGE COMPANDER—YD5020

DESCRIPTION

The YD5020 contains two variable gain circuits configured for compressing and expanding the dynamic range of an audio signal. One circuit is configured as an expander, while the other circuit can be configured as a compressor or expander. Each circuit has a full wave rectifier to provide average value information to a variable gain cell located in either the input stage or the feedback path.

FEATURES

- *Low voltage operation: $V_{opr}=1.8\sim 5.0V$
- *Decreasing external component
- *Built in compressor and expander mute circuit
- *Unity gain level set a $100mV_{rms}$
- *Response time adjustable

BLOCK DIAGRAM

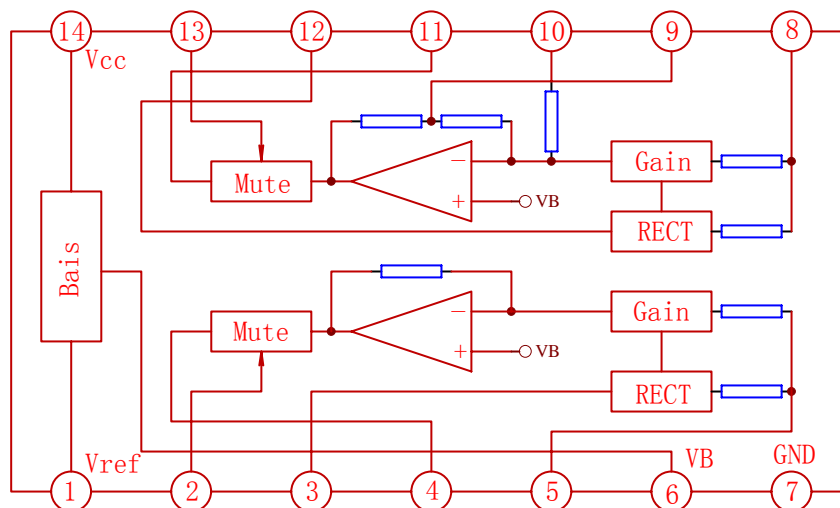

WuXi YouDa Electronics Co., Ltd

Add: No.5 Xijin Road, National Hi-Tech Industrial Development Zone, Wuxi Jiangsu China

Tel: 86-510-85205117 86-510-85205106 Fax: 86-510-85205110 Website: www.e-youda.com

SHENZHEN OFFICE Tel: 86-755-83740369 Fax: 86-755-83741418

PIN NO.	SYMBOL	PIN NO.	SYMBOL
1	Vref	8	COM FEED
2	EXP MUTE	9	COM CF
3	EXP FILTER	10	COM INPUT
4	EXP OUTPUT	11	COM OUTPUT
5	EXP INPUT	12	COM FILTER
6	VB	13	COM MUTE
7	GND	14	Vcc

ABSOLUTE MAXIMUM RATINGS (Tamb=25°C)

PARAMETER	SYMBOL	VALUE	UNIT
Supply Voltage	Vcc	10	V
Power Dissipation	P _D	410	mW
Operating Temperature	Topr	-20~+75	°C
Storage Temperature	Tstg	-55~+150	°C

OPERATION CONDITIONS (Vcc=3V, Tamb=25°C, Unless otherwise specified)

PARAMETER	SYMBOL	VALUE	UNIT
Supply Voltage	Vcc	1.8~5.0	V
Input Frequency Range	f _{in}	100~20k	Hz
Compressor Input Voltage	V _{inc}	700	mVrms
Expander Input Voltage	V _{ine}	316	mVrms

ELECTRICAL CHARACTERISTICS ($V_{CC}=3V, T_{amb}=25^{\circ}C, f=1kHz$, Unless otherwise specified)

Parameter	Symbol	Test Condition	Min.	Typ.	Max.	Unit
Supply Current	Iccq	Vin=0		3.1		mA
Compressor						
0dB Gain	G _{C0}	Vinc=100mV, 0dB	-1.5	0	1.5	dB
Gain Error (Note)	G _{C1}	Vinc=316mV, 10dB	-1.0	0	1.0	dB
	G _{C2}	Vinc=10mV, -20dB	-1.0	0	1.0	dB
	G _{C3}	Vinc=1mV, -40dB	-1.0	0	1.0	dB
	G _{C4}	Vinc=100 μ V, -60dB	-1.0	0	1.0	dB
Distortion	THD _C	Vinc=100mV, f=1kHz		0.3	1.5	%
Noise Output	V _{N0c}	Rg=600 Ω		0.8	5.0	mV
Ripple Rejection Ratio	RR _C	Vcc=1kHz, 3V(DC), 100mV		-25	-18	dB
Cross Talk (C→E)	CTc	Vinc=100mV, EXP Output		-72	-50	dB
Muting Attenuation	Attc	Vinc=100mV, Vpin13=GND		-65	-50	dB
Input Impedance	Rinc	PIN 10		20		k Ω
Expander Section						
0dB Gain	G _{e0}	Vine=100mV, 0dB	-1.5	0	1.5	dB
Gain Error (Note)	G _{e1}	Vine=178mV, 5dB	-1	0	1	dB
	G _{e2}	Vine=31.6mV, -10dB	-1	0	1	dB
	G _{e3}	Vine=10mV, -20dB	-1	0	1	dB
	G _{e4}	Vine=3.16mV, -30dB	-1	0	1	dB
Distortion	THD _e	Vine=100mV, f=1kHz		0.4	1.5	%
Noise Output	V _{N0e}	Rg=600 Ω		0.06	5.0	mV
Ripple Rejection Ratio	RR _e	Vcc=1kHz, 3V(DC), 100mV		-58	-38	dB
CrossTalk (E→C)	CTe	Vine=100mV, COM Output		-34	-24	dB
Muting Attenuation	Atte	Vine=316mV, Vpin2=GND		-70	-50	dB
Input Impedance	Rine	PIN 4		4.3		k Ω

(Note1) Gain Error= (Vout-20dB) - Vin × K Compressor: K=0.5 Expander: K=2

APPLICATION CIRCUIT

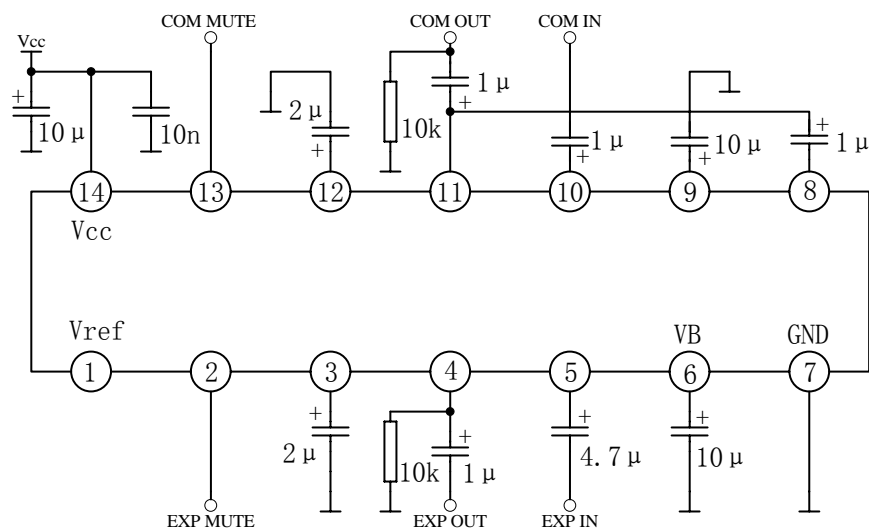

OUTLINE DRAWING

SOP-14

unit:mm

