

SPECIFICATION



LCD Module specification

YM12864-75

JAN, 20, 2006
Version 1.0



Dalian Good Display Co., Ltd.

Tel: +86-411-84619565

Fax: +86-411-84619585

WebSite: <http://www.good-lcd.com>

REVISION RECORD		
REV. NO.	DATA	REVISION ITEMS
1.0	JAN 20, 2006	First Release Version

Contents

1.Scope-----	4
2.Warranty-----	4
3.Features-----	4
4.Mechanical Diagram-----	6
5.I/O Terminal-----	7
6. Quality Level-----	9
7.Reliability-----	13
8.Handling Precautions-----	13
9.Precautions for Use-----	14

1.Scope

This manual defines general provisions as well as inspection standards for standard LCD module. If the event of unforeseen problem or unspecified items may occur, please contact the nearest supplier or our company.

2.Warranty

If module is not stored or used as specified in this manual, it will be void the 12- month warranty.

3.Features

3-1. Features

- (1) Display mode: { Transflective type
STN LCD
- (2) Display color: { Display dots: Black
Background:Yellow-Green
- (3) Display Fonts: Graphics Matrix
- (4)Input data: 8-bit parallel data interfaced from a MPU
- (5) Multiplex ratio: 1/64 Duty, 1/9 Bias
- (6)Viewing direction: 6 O'clock
- (7) Backlight: Yellow-Green LED
- (8) Controller: KS0108
- (9) Heater: Built-in, Booting up at -20 degrees C.

3-2. Mechanical features

Item	Specifications	Unit
Outline dimensions	93.0(W)×70.0(H) ×13.5Max.(T)	mm
Viewing Area	72.0(W)×40.0(H)	mm
Image Area	66.52(W)×33.24(H)	mm
Number of Dots	128(W) ×64(H)	mm
Dot Size	0.48(W)×0.48(H)	mm
Dot Pitch	0.52(W)×0.52(H)	mm
Weight	---	g

3-3. Absolute maximum ratings

Item	Symbol	Condition	Min	Max	Units
Power supply for logic	Vdd	25℃	- 0.3	7.0	V
Operating voltage for LCD	Vee	25℃	VDD-19.0	Vdd+0.3	V
Input voltage	Vin	25℃	- 0.3	Vdd+0.3	V
Operating temperature	Top	---	- 40	70	℃
Storage temperature	Tstg	---	- 45	75	℃

Note:

- 1) The modules may be destroyed if they are used beyond absolute maximum ratings. In ordinary operation, it is desirable to use them within recommended operation conditions. Using the modules beyond these conditions may cause malfunction and poor reliability.
- 2) All voltage values are referenced to GND=0V.

3-4 Electrical characteristics (VDD=5.0V, Vss=0V, Ta = 25°C)

Item	Symbol	Condition	Min.	Typ.	Max.	Unit
Power Voltage	Logic	Vdd	---	5.0	---	V
	LCDdrive	Vdd-Vee	---	9.4	---	
Input High Voltage	Vih1		0.7Vdd	---	Vdd	
	Vih2		2.0	---	Vdd	
Input Low Voltage	Vil1		0	---	0.3Vdd	
	Vil2		0	---	0.8	
Output Voltage	"H" Level	Voh	-Ioh=200uA	2.4	---	
	"L" Level	Vol	Iol=1.6mA	---	0.4	
Frame Frequency	Fosc	Vdd=3.0V Rf=75k $\Omega \pm 2\%$	190	270	350	KHz
Power Consumption	Idd		---	1.3	---	mA

Note: All the dots are in the static state.

3-5 LED back light specifications

(Users may select DM12864-05 with or without backlight according to their own needs.)

Item	Unit	Standard Values			Condition
		Min.	Typ.	Max.	
Supply Voltage	V	—	4.2	---	—
Current	mA	---	240	---	---
Luminous Color	—	Yellow green			---
Operating Temp.	°C	-40 ~ +70			—
Storage Temp.	°C	-45 ~ +80			—

4. Mechanical Diagram

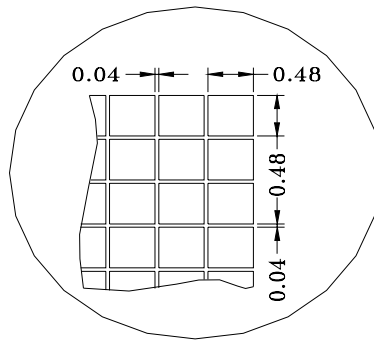
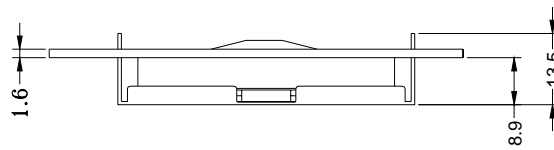
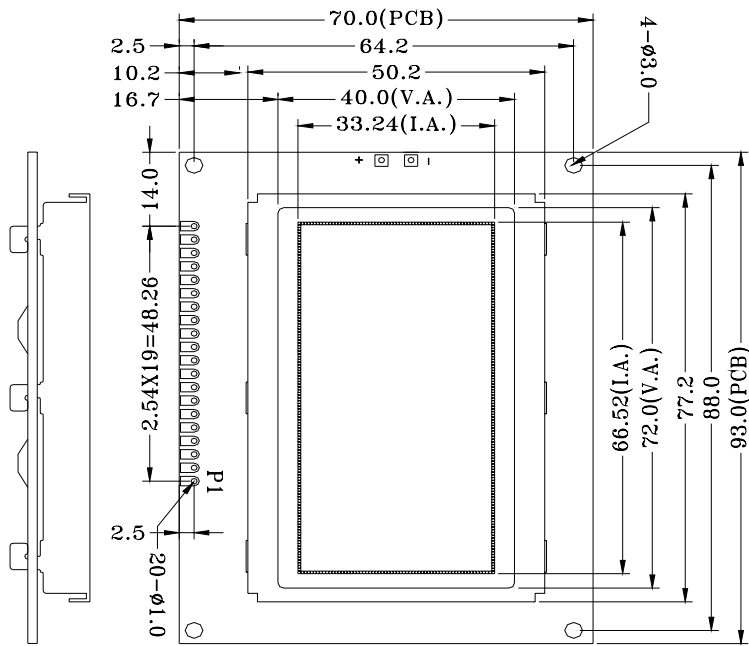

NOTE:
 TOLERANCES UNLESS OTHERWISE SPECIFIED: ± 0.2
 ALL DIMENSIONS ARE IN mm

5.I/O Terminal

5-1 I/O Connection

Pin No.	Symbol	Function
1	VSS	Power supply (GND)
2	VDD	Power supply (+)
3	V0	Contrast adjust
4	D/I	Input terminal, interfaced with MPU Register select signal D/I=0, Instruction register (for write) Busy flag: address counter (for read) D/I=1, Data register (for write and read)
5	R/W	Input terminal, interfaced with MPU Data read/write R/W=1 Read ; R/W=0 Write
6	E	Input terminal, interfaced with MPU Enabe signal
7-14	DB0-DB7	Data bus line
15	CS1	This is the chip select signal.
16	CS2	This is the chip select signal.
17	RST	When /RST is set to "L," the settings are initialized.
18	VEE	Power supply for LCD
19	BL+	Power supply for LED (+)
20	BL-	Power supply for LED (-)

5-2 Signal timing diagra

Characteristic	Symbol	Min	Typ	Max	Unit
E Cycle	t_C	1000	-	-	ns
E High Level Width	t_{WH}	450	-	-	ns
E Low Level Width	t_{WL}	450	-	-	ns
E Rise Time	t_R	-	-	25	ns
E Fall Time	t_F	-	-	25	ns
Address Set-Up Time	t_{ABU}	140	-	-	ns
Address Hold Time	t_{AH}	10	-	-	ns
Data Set-Up Time	t_{DBU}	200	-	-	ns
Data Delay Time	t_D	-	-	320	ns
Data Hold Time (Write)	t_{DHW}	10	-	-	ns
Data Hold Time (Read)	t_{DHR}	20	-	-	ns

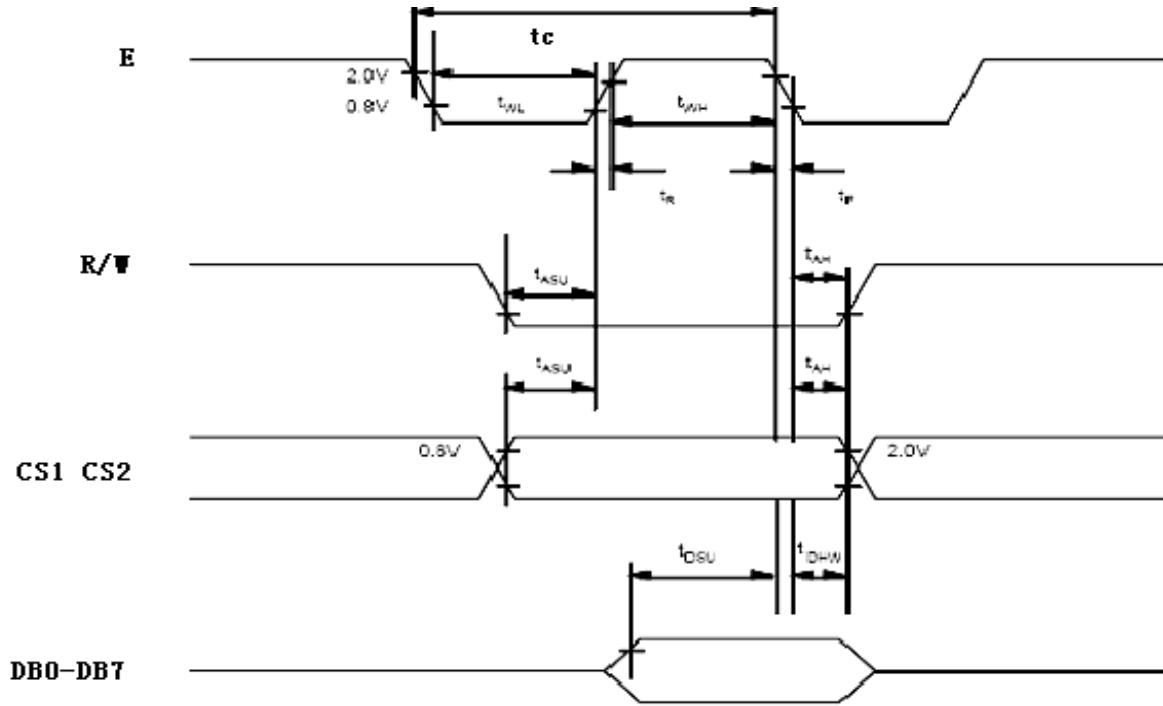

MPU Write timing

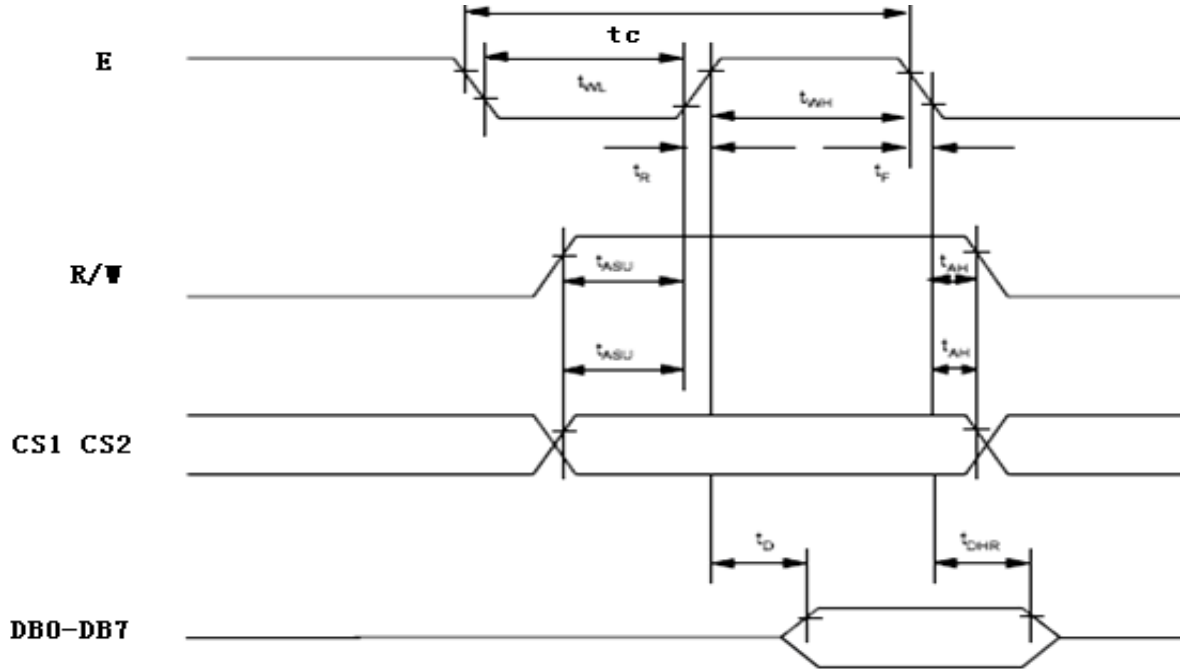

MPU Read timing

5-3 Display command

Instruction	RS	R/W	DB7	DB6	DB5	DB4	DB3	DB2	DB1	DB0	Function	
Display ON/OFF	L	L	L	L	H	H	H	H	H	L/H	Controls the display on or off. Internal status and display RAM data is not affected. L:OFF, H:ON	
Set Address (Y address)	L	L	L	H	Y address (0~63)						Sets the Y address in the Y address counter.	
Set Page (X address)	L	L	H	L	H	H	H			Page (0~7)	Sets the X address at the X address register.	
Display Start Line (Z address)	L	L	H	H	Display start line (0~63)						Indicates the display data RAM displayed at the top of the screen.	
Status Read	L	H	B U S Y	L	O N / O F F	R E S E T	L	L	L	L	Read status. BUSY L: Ready H: In operation ON/OFF L: Display ON H: Display OFF RESET L: Normal H: Reset	
Write Display Data	H	L	Write Data									Writes data (DB0:7) into display data RAM. After writing instruction, Y address is increased by 1 automatically.
Read Display Data	H	H	Read Data									Reads data (DB0:7) from display data RAM to the data bus.

Note:The details of The Display Commands ,please refer to KS0108/PT6608data sheet.

6. Quality Level

6-1 Inspection conditions

6-1-1 The environmental conditions for inspection shall be as follows:

Room temperature: $20 \pm 3^\circ\text{C}$

Humidity: $65 \pm 20\% \text{ RH}$

6-1-2 The external visual inspection:

The inspection shall be performed by using a 20W fluorescent lamp for illumination and the distance between LCD and the eyes of the inspector should be at least 30cm.

(1) Light method

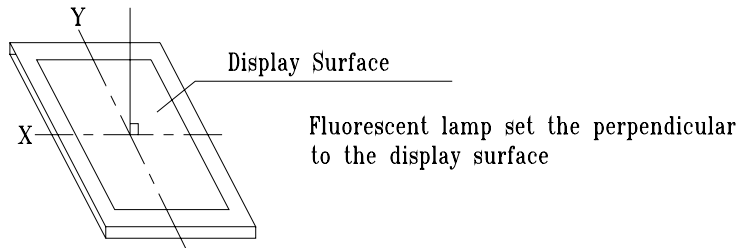

(2) Inspection distance and angle

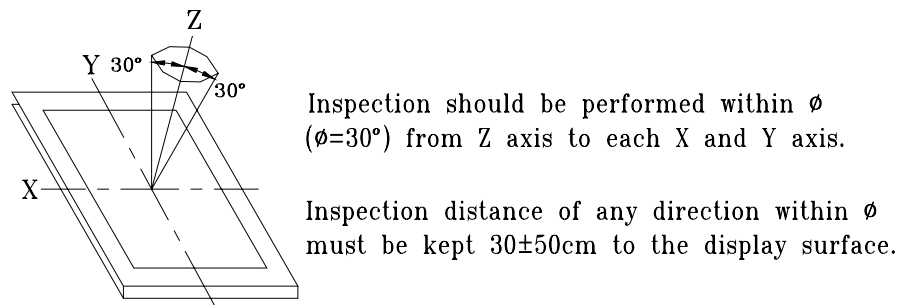

6-2 Sampling procedures for each item's acceptance level table

Defect type	Sampling procedure	AQL
Major defect	MIL-STD-105D Inspection Level I Normal inspection Single sample inspection	Q/GD-07-2006(1)
Minor defect	MIL-STD-105D Inspection Level I Normal inspection Single sample inspection	Q/GD-07-2006(1)

6-3 Classification of defects

6-3-1 Major defect

A major defect refers to a defect that may substantially degrade usability for product applications.

6-3-2 Minor defect

A minor defect refers to a defect that deviates from existing standards almost unrelated to the effective use of the product or its operation.

6-4 Inspection standar

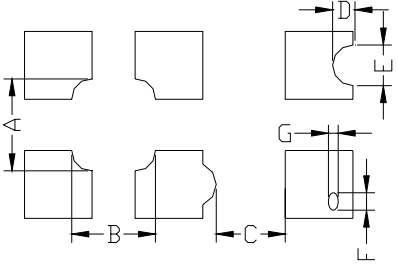
Item	Criterion for defects	Defect type																					
1) Display on inspection	(1) Non display (2) Vertical line is deficient (3) Horizontal line is deficient (4) Cross line is deficient	Major																					
2) Black / White spot	<table border="1" data-bbox="619 517 1086 696"> <thead> <tr> <th>Size Φ (mm)</th> <th>Acceptable number</th> </tr> </thead> <tbody> <tr> <td>$\Phi \leq 0.3$</td> <td>Ignore (note)</td> </tr> <tr> <td>$0.3 < \Phi \leq 0.45$</td> <td>3</td> </tr> <tr> <td>$0.45 < \Phi \leq 0.6$</td> <td>1</td> </tr> <tr> <td>$0.6 < \Phi$</td> <td>0</td> </tr> </tbody> </table> <p>(Note) Not allowed if four more spots crowd together</p>	Size Φ (mm)	Acceptable number	$\Phi \leq 0.3$	Ignore (note)	$0.3 < \Phi \leq 0.45$	3	$0.45 < \Phi \leq 0.6$	1	$0.6 < \Phi$	0	Minor											
Size Φ (mm)	Acceptable number																						
$\Phi \leq 0.3$	Ignore (note)																						
$0.3 < \Phi \leq 0.45$	3																						
$0.45 < \Phi \leq 0.6$	1																						
$0.6 < \Phi$	0																						
3) Black / White line	<table border="1" data-bbox="587 763 1257 1066"> <thead> <tr> <th>Length (mm)</th> <th>Width (mm)</th> <th>Acceptable number</th> </tr> </thead> <tbody> <tr> <td>$L \leq 10$</td> <td>$W \leq 0.03$</td> <td>Ignore</td> </tr> <tr> <td>$5.0 \leq L \leq 10$</td> <td>$0.03 < W \leq 0.04$</td> <td>3</td> </tr> <tr> <td>$5.0 \leq L \leq 10$</td> <td>$0.04 < W \leq 0.05$</td> <td>2</td> </tr> <tr> <td>$1.0 \leq L \leq 10$</td> <td>$0.05 < W \leq 0.06$</td> <td>2</td> </tr> <tr> <td>$1.0 \leq L \leq 10$</td> <td>$0.06 < W \leq 0.08$</td> <td>1</td> </tr> <tr> <td>$L \leq 10$</td> <td>$0.08 < W$</td> <td>follows 2) point defect</td> </tr> </tbody> </table> <p>Defects separate with each other at an interval of more than 20mm.</p>	Length (mm)	Width (mm)	Acceptable number	$L \leq 10$	$W \leq 0.03$	Ignore	$5.0 \leq L \leq 10$	$0.03 < W \leq 0.04$	3	$5.0 \leq L \leq 10$	$0.04 < W \leq 0.05$	2	$1.0 \leq L \leq 10$	$0.05 < W \leq 0.06$	2	$1.0 \leq L \leq 10$	$0.06 < W \leq 0.08$	1	$L \leq 10$	$0.08 < W$	follows 2) point defect	Minor
Length (mm)	Width (mm)	Acceptable number																					
$L \leq 10$	$W \leq 0.03$	Ignore																					
$5.0 \leq L \leq 10$	$0.03 < W \leq 0.04$	3																					
$5.0 \leq L \leq 10$	$0.04 < W \leq 0.05$	2																					
$1.0 \leq L \leq 10$	$0.05 < W \leq 0.06$	2																					
$1.0 \leq L \leq 10$	$0.06 < W \leq 0.08$	1																					
$L \leq 10$	$0.08 < W$	follows 2) point defect																					
4) Display pattern	 <p>[Unit: mm]</p> <table border="1" data-bbox="587 1435 1150 1514"> <thead> <tr> <th>$A+B \leq 0.45$</th> <th>$0 < C$</th> <th>$D+E \leq 0.35$</th> <th>$F+G \leq 0.35$</th> </tr> </thead> <tbody> <tr> <td>2</td> <td></td> <td>2</td> <td>2</td> </tr> </tbody> </table> <p>Note: 1) Up to 3 damages acceptable 2) Not allowed if there are two or more pinholes every 3 of fourths inch.</p>	$A+B \leq 0.45$	$0 < C$	$D+E \leq 0.35$	$F+G \leq 0.35$	2		2	2	Minor													
$A+B \leq 0.45$	$0 < C$	$D+E \leq 0.35$	$F+G \leq 0.35$																				
2		2	2																				
5) Spot-like contrast irregularity	<table border="1" data-bbox="635 1650 1126 1830"> <thead> <tr> <th>Size Φ (mm)</th> <th>Acceptable Number</th> </tr> </thead> <tbody> <tr> <td>$\Phi \leq 0.7$</td> <td>Ignore (note)</td> </tr> <tr> <td>$0.7 < \Phi \leq 1.0$</td> <td>3</td> </tr> <tr> <td>$1.0 < \Phi \leq 1.5$</td> <td>1</td> </tr> <tr> <td>$1.5 < \Phi$</td> <td>0</td> </tr> </tbody> </table> <p>Note: 1) Conformed to limit samples. 2) Intervals of defects are more than 30mm.</p>	Size Φ (mm)	Acceptable Number	$\Phi \leq 0.7$	Ignore (note)	$0.7 < \Phi \leq 1.0$	3	$1.0 < \Phi \leq 1.5$	1	$1.5 < \Phi$	0	Minor											
Size Φ (mm)	Acceptable Number																						
$\Phi \leq 0.7$	Ignore (note)																						
$0.7 < \Phi \leq 1.0$	3																						
$1.0 < \Phi \leq 1.5$	1																						
$1.5 < \Phi$	0																						

LCD Module User Manual

Item	Criterion for defects			Defect type
	Size Φ (mm)	Acceptable Number		
6) Bubbles in polarizer	$\Phi \leq 0.4$	Ignore (note)		Minor
	$0.4 < \Phi \leq 0.65$	2		
	$0.65 < \Phi \leq 1.2$	1		
	$1.2 < \Phi$	0		
7) Scratches and dent on the polarizer	Scratches and dent on the polarizer shall be in the accordance with "2) Black/white spot", and "3) Black/White line".			Minor
8) Stains on the surface of LCD panel	Stains which cannot be removed even when wiped lightly with a soft cloth or similar cleaning.			Minor
9) Rainbow color	No rainbow color is allowed in the optimum contrast on state within the active area.			Minor
10) Viewing area encroachment	Polarizer edge or line is visible in the opening viewing area due to polarizer shortness or sealing line.			Minor
11) Bezel appearance	Rust and deep damages that are visible in the bezel are rejected.			Minor
12) Defect of land surface contact	Evident crevices that are visible are rejected.			Minor
13) Parts mounting	(1) Failure to mount parts (2) Parts not in the specifications are mounted (3) For example: Polarity is reversed, HSC or TCP falls off.			Major
14) Part alignment	(1) LSI, IC lead width is more than 50% beyond pad outline. (2) More than 50% of LSI, IC leads is off the pad outline.			Minor
15) Conductive foreign matter (solder ball, solder hips)	(1) $0.45 < \Phi$, $N \geq 1$			Major
	(2) $0.3 < \Phi \leq 0.45$, $N \geq 1$ Φ : Average diameter of solder ball (unit: mm)			Minor
	(3) $0.5 < L$, $N \geq 1$ L : Average length of solder chip (unit: mm)			Minor
16) PCB pattern damage	(1) Deep damage is found on copper foil and the pattern is nearly broken.			Major
	(2) Damage on copper foil other than 1) above			Minor
17) Faulty PCB correction	(1) Due to PCB copper foil pattern burnout, the pattern is connected, using a jumper wire for repair; 2 or more places are corrected per PCB. (2) Short-circuited part is cut, and no resist coating has been performed.			Minor
18) Bezel flaw	Bezel claw missing or not bent			Minor
19) Indication on name plate (sampling indication label)	(1) Failure to stamp or label error, or not legible.(all acceptable if legible) (2) The separation is more than 1/3 for indication discoloration, in which the characters can be checked.			Minor

7. Reliability

7-1 Lifetime

50,000 hours (25°C in the room without ray of sun)

7-2 Items of reliability

Item	Condition	Criterion
1) High Temperature Operating	60°C 96hrs	No cosmetic failure is allowable. Contrast ratio should be between initial value ±10%. Total current consumption should be below double of initial value.
2) Low Temperature Operation	-20°C 96hrs	
3) Humidity	40°C, 90%RH, 96hrs	No cosmetic failure is allowable. Contrast ratio should be between initial value ±20%. Total current consumption should be below double of initial value.
4) High Temperature	70°C 96hrs	
5) Low Temperature	-30°C 96hrs	
6) Thermal shock	25°C→30°C→25°C→70°C 5(min) 30(min) 5(min) 30(min) 5 cycle, 55~60%RH	
7) Vibration	10~55~10hz amplitude: 1.5mm 2hrs for each direction (X,Y,Z)	No defects in cosmetic and operational function are allowable. Total current consumption should be below double of initial value.

8. Handling Precautions

8-1 Mounting method

A panel of LCD module consists of two thin glass plates with polarizers that easily get damaged.

And since the module is so constructed as to be fixed by utilizing fitting holes in the printed circuit board (PCB).

Extreme care should be used when handling the LCD modules.

8-2 Cautions of LCD handling and cleaning

When cleaning the display surface, use soft cloth with solvent (recommended below) and wipe lightly.

- Isopropyl alcohol
- Ethyl alcohol
- Trichlorotrifluoroethane

Do not wipe the display surface with dry or hard materials that will damage the polarizer surface.

Do not use the following solvent:

- Water
- Ketone
- Aromatics

8-3 Caution against static charge

The LCD module use C-MOS LSI drivers. So we recommend you:

Connect any unused input terminal to V_{dd} or V_{ss} . Do not input any signals before power is turned on, and ground your body, work/assembly areas, assembly equipment to protect against static electricity.

8-4 Packaging

- Module employs LCD elements, and must be treated as such. Avoid intense shock and falls from a height. To prevent modules from degradation, do not operate or store them exposed direct to sunshine or high temperature/humidity.

8-5 Caution for operation

- It is an indispensable condition to drive LCD module within the limits of the specified voltage since the higher voltage over the limits may cause the shorter life of LCD module. An electrochemical reaction due to DC (direct current) causes LCD undesirable deterioration so that the uses of DC (direct current) drive should be avoided.
- Response time will be extremely delayed at lower temperature than the operating temperature range and on the other hand at higher temperature LCD module may show dark color in them. However those phenomena do not mean malfunction or out of order of LCD module, which will come back in the specified operating temperature.

8-6 Storage

In the case of storing for a long period of time, the following ways are recommended:

- Storage in polyethylene bag with the opening sealed so as not to enter fresh air outside in it. And with not desiccant.
- Placing in a dark place where neither exposure to direct sunlight nor light is. Keeping the storage temperature range.
- Storing with no touch on polarizer surface by any thing else.

8-7 Safety

- It is recommendable to crash damaged or unnecessary LCD into pieces and to wash off liquid crystal by either of solvents such as acetone and ethanol, which should be burned up later.
- When any liquid leaked out of a damaged glass cell comes in contact with your hands, please wash it off well at once with soap and water.

9. Precautions for Use

9-1 Both parties should provide a limit sample on an occasion when both parties agree its necessity.

The judgement by a limit sample shall take effect after the limit sample has been established and confirmed by both parties

9-2 On the following occasions, the handling of problem should be decided through discussion and agreement between responsible of the both parties.

-When a question is arisen in this manual.

-When a new problem is arisen which is not specified in this manual.

-Some problem is arisen due to the change of inspection and operating conditions in users.

-When a new problem is arisen at the customer's operating set for sample evaluation in the customer site.