

SPECIFICATION



深圳耀宇
SHENZHEN YAOYU



YM300T-006AT

MaY, 19, 2009
Version 1.0

CONTENTS

1.	FEATURES-----	1
2.	BLOCK DIAGRAM &APPLICATION CIRCUIT -----	1
3.	OUTLINE DIMENSIONS-----	2
4.	INTERFACE PIN CONNECTIONS-----	4
5.	ELECTRICAL CHARACTERISTICS-----	4
6.	Electro-Optical Characteristics -----	5
7.	QUALITY GUARANTEE & INSPECTION CRITERIA ---	5
8.	RELIABILITY -----	7

1. FEATURES

ITEM	STANDARD VALUE	UNIT
LCD Type	3.0"QVGA TFT-LCD (Thin Film Transistor Liquid Crystal Display)	---
Viewing Direction	12:00	O'clock
Backlight Type	4-parallel-White LED	---
Module Outsize	45.04*77*3.6(WITH TP)	mm
TP Viewing area	40.88*71.00	mm
TP Active area	39.88*70.00	mm
LCD Active area	38.88*64.80	mm
Dot Number	240(RGB) ×400	---
Dot size	0.162*0.162	mm
Operation temperature	-20 ~70	℃
Storage temperature	-30 ~80	℃
Driver IC	R61509V	---
Interface mode	8080 System 16 bit Interface	---

Remark:

2. BLOCK DIAGRAM

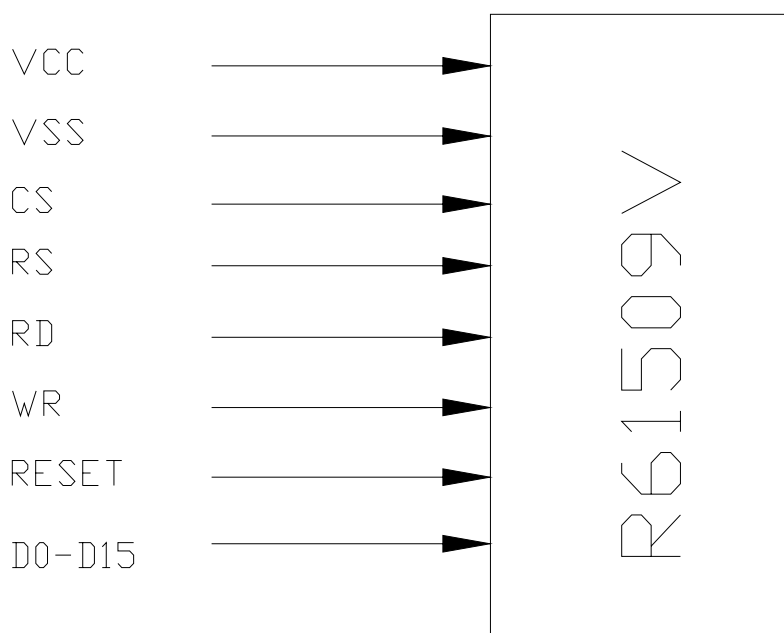

3. OUTLINE DIMENSIONS

由 Autodesk 教育版产品制作

客户确认签名:

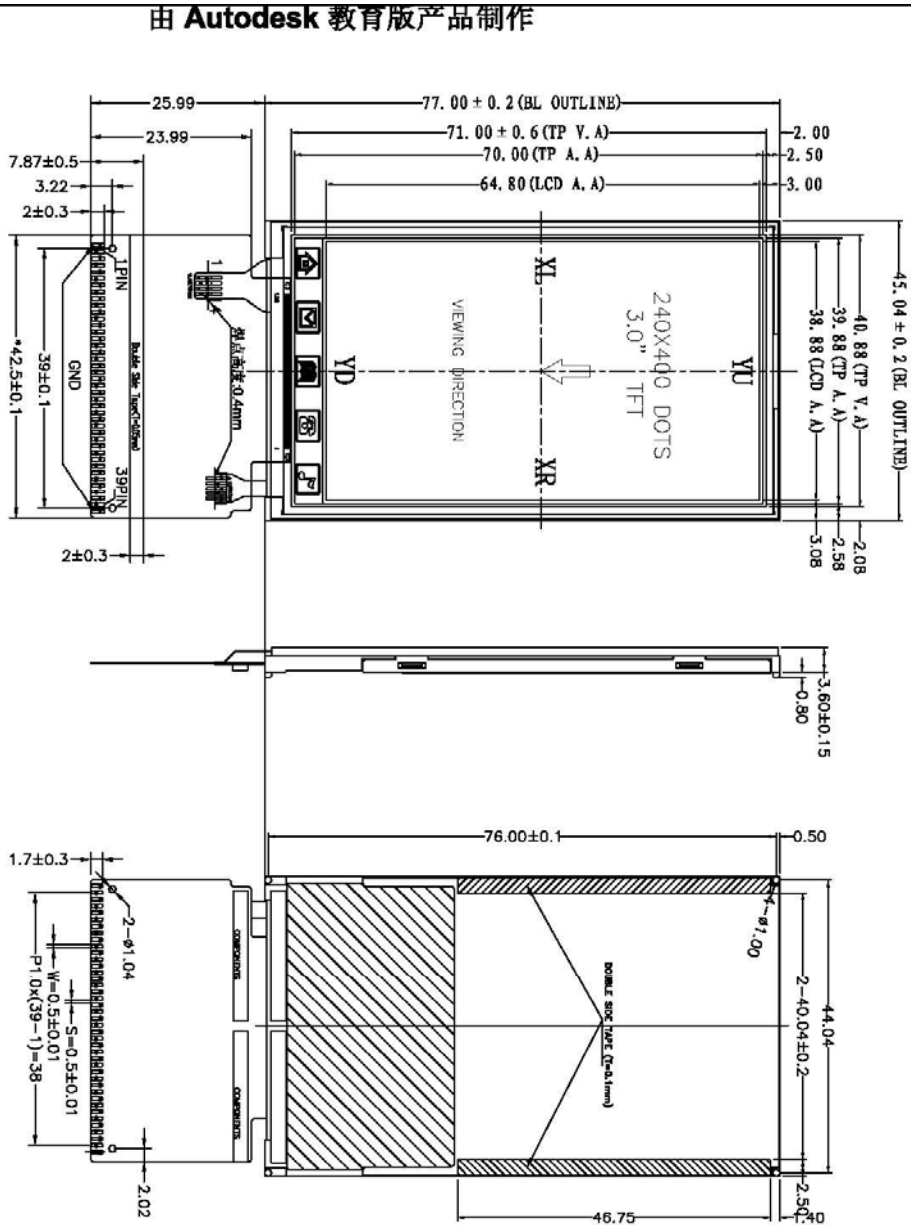

NOTES:

1. DISPLAY TYPE: 3.0° (16:9) TFT, Transmissive
2. OPERATING TEMP: -20° C ~ 70° C
3. STORAGE TEMP: -30° C ~ 80° C
4. MAIN LCD DRIVER: R61509V
5. BACKLIGHT: 4 CHIP-WHITE LED
6. GENERAL TOLERANCE: ±0.2

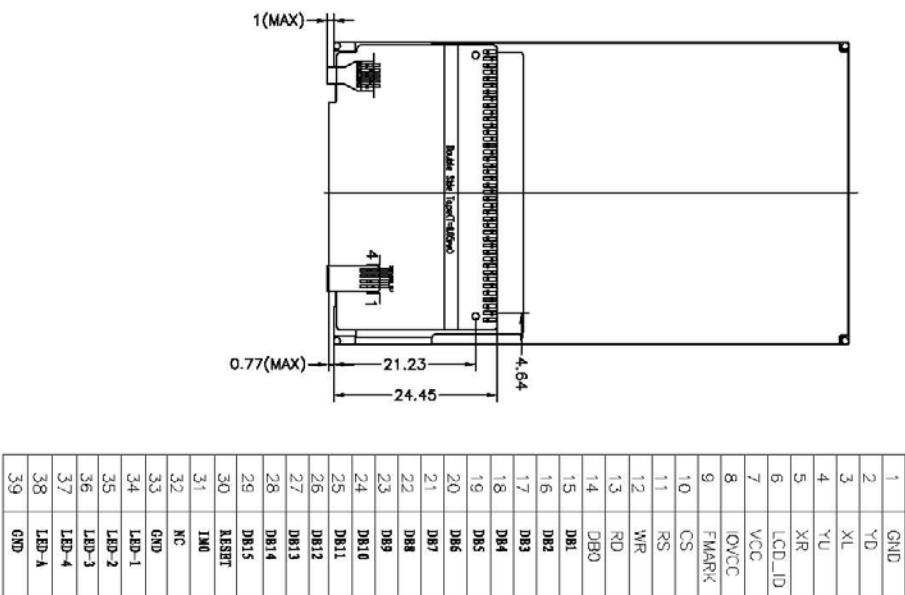
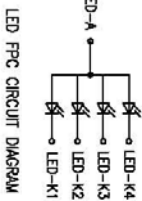

由 Autodesk 教育版产品制作

由 Autodesk 教育版产品制作

深圳市耀宇科技有限公司
 SHENZHEN YAO YU TECHNOLOGY CO., LTD

出图编号	YM300T-006AT 090602	设计	唐祥云/090602
产品编号	YM300T-006AT	客户编号	

单位	mm	公差	±0.2	页数	1/1	视角	
版本	A	公差	±0.5°	比例	1:1		

4. NTERFACE PIN CONNECTIONS

PIN	SYMBOL	FUNCTION
1	GND Gr	ound
2	YD	TP bottom electrode
3	XL	TP left electrode
4	YU	TP top electrode
5	XR	TP right electrode
6	LCD_ID	No connect
7	VCC	Power supply (2.8 V)
8	IOVCC	
9	FMARK	No connect
10	/CS	Chip select input pin (“Low” enable).
11	RS	Display data / Command selection pin
12	/WR	Write pin
13	/RD	Read pin
14	DB0	Data bus
15	DB1	
16	DB2	
17	DB3	
18	DB4	
19	DB5	
20	DB6	
21	DB7	
22	DB8	
23	DB9	
24	DB10	
25	DB11	
26	DB12	
27	DB13	
28	DB14	
29	DB15	
30	/RESET	Reset pin
31	IM0	No connect
32	NC	No connect
33	GND Gr	ound
34	LED-K1	Backlight ground
35	LED-K2	
36	LED-K3	
37	LED-K4	
38	LED-A	Backlight power supply
39	GND Gr	ound

5. ELECTRICAL CHARACTERISTICS

5.1 ABSOLUTE MAXIMUM RATING

Please Refer to the SPEC of **R61509V**.

5.2 DC Characteristics

Please Refer to the SPEC of **R61509V**.

5.3 AC Characteristics

Please Refer to the SPEC of **R61509V**.

6. Electro-Optical Characteristics

6.1 Backlight Unit

Item	Symbol	Min	Typ.	Max	Unit	Remark
Input voltage	Vci	2.5	3.2	3.3	V	-
Current ILCD		---	18	---	mA/chip	-
ICE	X 0.2	6	-	0.30	-	X>Y
	Y 0.2	7	-	0.31	-	
Brightness -		-----	3000	----	cd/m ²	
Luminous Intensity Ratio	-	---	----	20	%	-

6.2 LCD panel

T .B.D

7. QUALITY GUARANTEE & INSPECTION CRITERIA

7.1 Appearance inspection

Appearance inspection should be done under the following condition.

- (1) In the dark room.
- (2) The distance from eyes to LCD must be 30 cm.
- (3) Viewing direction must be within 30 degrees to vertical line of LCD center.

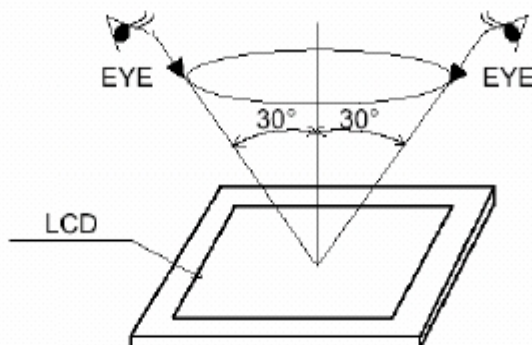

7.2 Definition of A zone, B zone and C zone

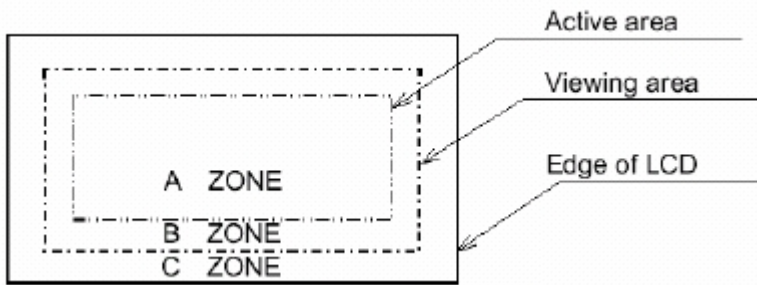

7.3 Electrical Testing

1. Missing vertical, horizontal segment, segment contrast defect.
2. Missing character, dot or icon.
3. Display malfunction.
4. No function or no display.
5. Current consumption exceeds product specifications.
6. LCD viewing angle defect.
7. Mixed product types.
8. Contrast defect

7.4 Black or white spots on LCD (display only)

1. White and black spots on display $\leq 0.20\text{mm}$, no more than three white or black spots present.
2. Densely spaced: No more than two spots or lines within 5mm

7.5 LCD black spots, white spots, contamination (non-display)

1. Round type: As following drawing

$$\psi = (x+y)/2$$

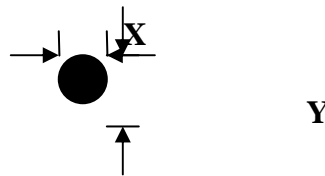

SIZE Acceptable	QTY
$\psi \leq 0.10$	Accept no dense
$0.10 < \psi \leq 0.15$ 2	
$0.15 < \psi \leq 0.20$	1
total	2

2. Line Type: (As following drawing)

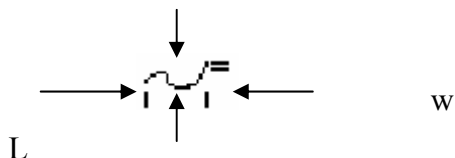

Length	Width	Acceptable QTY
---	$W \leq 0.02$	Accept no dense
$L \leq 3.0$	$0.02 < W \leq 0.03$	2
$L \leq 2.5$	$0.03 < W \leq 0.05$	
---	$0.05 < W$	As round type

7.6 Polarizer bubbles

If bubbles are visible, judge using black spot specifications, not easy to find, must check in specify direction.

Size ψ	Acceptable QTY
$\psi \leq 0.20$	Accept no dense
$0.20 < \psi \leq 0.50$	2

7.7 Chipped glass

Symbols:

a: Chip length b: Chip width c: Chip thickness

t: Glass thickness

1 ITO electrode

$a \leq t$

$b \leq 0.5\text{mm}$

$c \leq 3.0\text{mm}$

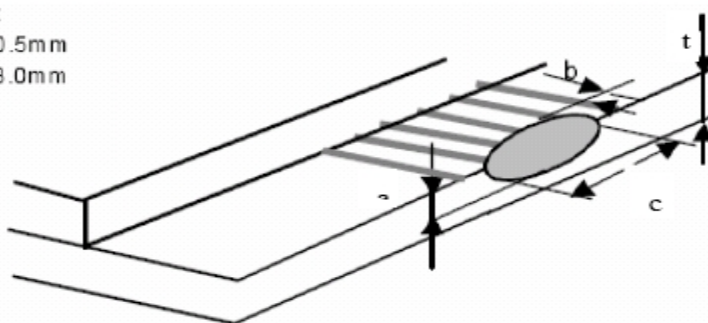

2 General ,corner portion

$a \leq t$

$b \leq 1.0\text{mm}$

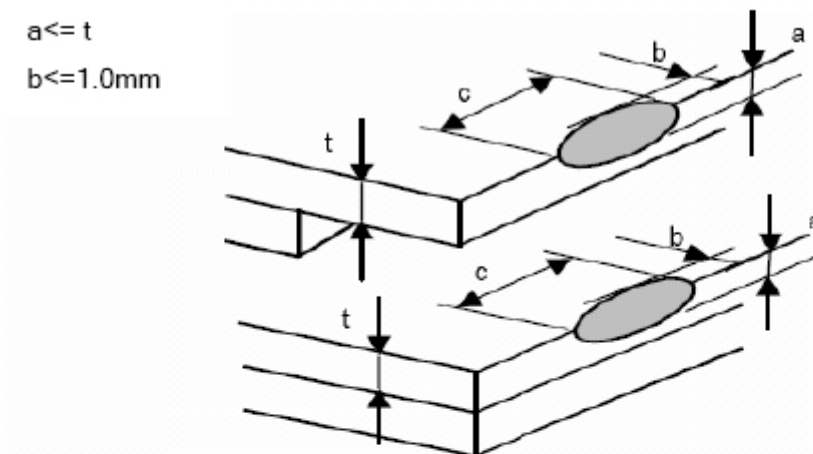

*Effective width of seal area shall be more than 0.3mm.

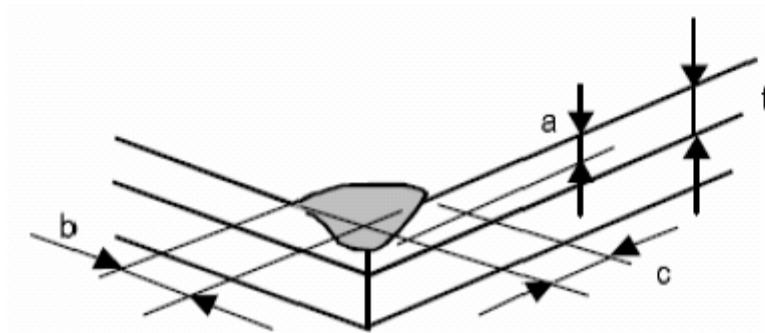

7.8 Backlight elements

1. Illumination source flickers when lit.
2. Spots or scratches that appear when lit must be judged using LCD spot, lines and contamination standards.
3. Backlight doesn't light or color is wrong

7.9 Soldering

1. No unmelted solder paste may be present on the PCB.
2. No cold solder joints, missing solder connections, oxidation or icicle.
3. No residue or solder balls on PCB.
4. No short circuits in components on PCB.

7.10 General appearance

1. No oxidation, contamination, curves or, bends on interface pin (OLB) of TCP.
2. No cracks on interface pin (OLB) of TCP
3. NO contamination, solder residue or solder balls on product.
4. The IC on the TCP may not be damaged, circuits.
5. The uppermost edge of the protective strip on the interface pin must be present or look as if it cause the interface pin to sever.
6. The residual rosin or tin oil of soldering (component or chip component) is not burned into brown or black color.
7. Sealant on top of the ITO circuit has not hardened
8. Pin type must match type in specification sheet.

9. LCD pin loose or missing pins.
10. Product packaging must the same as specified on packaging specification sheet.
11. Product dimension and structure must conform to product specification sheet.
12. The appearance of Heat Seal should not admit any dirt and break.

8. RELIABILITY

Test Item	Sample Type	Test Condition	Test result determinant gist
High temperature storage	Normal temperature	70 ± 3 °C;240H	the inspection of Appearance and function character.
	Broad temperature	80 ± 3 °C;240H	
Low temperature storage	Normal temperature	-20 ± 3 °C;240H	
	Broad temperature	-30 ± 3 °C;240H	
High temperature /humidity storage	Normal temperature	50 °C ± 3 °C,90% ± 3%RH;240H	
	Broad temperature	60 °C ± 3 °C,90% ± 3%RH;240H	
High temperature operation	Normal temperature	60 ± 3 °C;96H	No objection of the function character; no fatal objection of the appearance.
	Broad temperature	70 ± 3 °C;96H	
Low temperature operation	Normal temperature	0 ± 3 °C;96H	
	Broad temperature	-20 ± 3 °C;96H	
High temperature /humidity operation	Normal temperature	40 °C ± 3 °C,90% ± 3%RH;96H	
	Broad temperature	50 °C ± 3 °C,90% ± 3%RH;96H	
Temperature Shock	Normal temperature	-20 ± 3 °C,30min → 70 ± 3 °C,30min;10cycle	inspect the objections appearance、function & the whole structure
	Broad temperature	-30 ± 3 °C, 30min 80 ± 3, 30min;10cycle	The inspection of appearance、function & the whole structure

ESD test	ALL	Discharge modality: Air discharge. Discharge voltage: $\pm 2KV/\pm 4 KV/\pm 6K \pm 8KV/\pm 12KV/15KV$.no software error & objection in $\pm 2KV\sim\pm 12KV$,no hardware errors & objection in $\pm 15KV$.
		Discharge modality: Contact discharge Discharge voltage: $\pm 2KV/\pm 4 KV/\pm 6KV/\pm 8KV$	no software errors & objection in $\pm 2KV\sim\pm 12KV$,no hardware errors & objection in $\pm 8KV$.
Bend test	ALL	Bend velocity: 60time/min; Bendtimes:50000tims	Stimulate the folder's repeat folding, no objection of display function
Vibration test	ALL	frequencyrange:10HZ~55HZ;swing:0.75mm;Z-axist direction: 60min.	the inspection of appearance、function & the whole structure

9. PRECAUTIONS FOR USING LCD MODULES

Handing Precautions

(1) The display panel is made of glass. Do not subject it to a mechanical shock by dropping it or impact.

(2) If the display panel is damaged and the liquid crystal substance leaks out, be sure not to get any in your mouth. If the substance contacts your skin or clothes, wash it off using soap and water.

(3) Do not apply excessive force to the display surface or the adjoining areas since this may cause the color tone to vary.

(4) The polarizer covering the display surface of the LCD module is soft and easily scratched. Handle this polarizer carefully.

(5) If the display surface becomes contaminated, breathe on the surface and gently wipe it with a soft dry cloth. If it is heavily contaminated, moisten cloth with one of the following solvents :

- Isopropyl alcohol
- Ethyl alcohol

(6) Solvents other than those above-mentioned may damage the polarizer. Especially, do not use the following.

- Water
- Ketone
- Aromatic solvents

(7) Exercise care to minimize corrosion of the electrode. Corrosion of the electrodes is accelerated by water droplets, moisture condensation or a current flow in a high-humidity environment.

(8) Install the LCD Module by using the mounting holes. When mounting the LCD module make sure it is free of twisting, warping and distortion. In particular, do not forcibly pull or bend

the IO cable or the backlight cable.

(9) Do not attempt to disassemble or process the LCD module.

(10) NC terminal should be open. Do not connect anything.

(11) If the logic circuit power is off, do not apply the input signals.

(12) To prevent destruction of the elements by static electricity, be careful to maintain an optimum work environment.

- Be sure to ground the body when handling the LCD modules.
- Tools required for assembling, such as soldering irons, must be properly grounded.
- To reduce the amount of static electricity generated, do not conduct assembling and other work under dry conditions.

- The LCD module is coated with a film to protect the display surface. Exercise care when peeling off this protective film since static electricity may be generated.

Storage Precautions

When storing the LCD modules, avoid exposure to direct sunlight or to the light of fluorescent lamps. Keep the modules in bags (avoid high temperature, high humidity and low temperatures below 0°C). Whenever possible, the LCD modules should be stored in the same conditions in which they were shipped from our company.

Others

Liquid crystals solidify under low temperature (below the storage temperature range) leading to defective orientation or the generation of air bubbles (black or white). Air bubbles may also be generated if the module is subject to a low temperature.

If the LCD modules have been operating for a long time showing the same display patterns, the display patterns may remain on the screen as ghost images and a slight contrast irregularity may also appear. A normal operating status can be regained by suspending use for some time. It should be noted that this phenomenon does not adversely affect performance reliability.

To minimize the performance degradation of the LCD modules resulting from destruction caused by static electricity etc., exercise care to avoid holding the following sections when handling the modules.

- Exposed area of the printed circuit board.
- Terminal electrode sections.