

# D/A CONVERTER

2-Channel Serial & Binary input Floating D/A Converter

## YM3016 DAC(CD)

### ■ OUTLINE

The YM3016 : DAC-GS is a Floating D/A converter (referred to as DAC hereafter) with the 2-channel serial and 16-bit binary input or 2's complement input. It can produce analog output (16-bit dynamic range) which has 10-bit mantissa and 7-step exponent characteristic for the input digital signal.

### ■ FEATURES

- 16-bit input format can select either binary or 2's complement (due to built-in floating converter logic).
- Analog output can be obtained easily by adding a buffer operational amplifier, etc.
- 16-bit wide dynamic range.
- Capable of processing PCM sound source up to 2 channels.
- Equipped with a built-in analog switch for sample hold.
- Lower noise and less harmonic distortion and outstanding temperature characteristics.
- Made by the monolithic process of highly accurate thin film resistor and CMOS.
- Package type: 16 pin plastic SOP : YM3016F  
DIP : YM3016D
- +5V single power supply.

### ■ Electrical characteristics

#### ① Absolute Maximum Ratings

Item	Rating	Unit
Supply voltage	-0.3 ~ +15.0	V
High-level input voltage	V <sub>DD</sub> +0.3	V
Low-level input voltage	V <sub>SS</sub> -0.3	V
Operating ambient temperature	0 ~ 70	°C
Storing temperature	-50 ~ +125	°C

#### ② Recommended Operating Conditions

Item	Symbol	Min		Max	Unit
Supply voltage	V <sub>DD</sub>	4.75*	5.0	5.25	V
	V <sub>SS</sub>	0	0	0	V
Input signal voltage	CLOCK				
	SD	0	—	V <sub>DD</sub>	V
	SMP1, 2				
	ICL				
Operating ambient temperature	T <sub>a</sub>	0	—	70	°C

#### ③ DC Characteristics

Item	Symbol	Measuring Conditions	Min	Typ	Max	Unit
High-level input voltage	V <sub>IH</sub>		0.66V <sub>DD</sub>	—	—	V
Low-level input voltage	V <sub>IL</sub>		—	—	0.30V <sub>DD</sub>	V
Input current	I <sub>IN</sub>	V <sub>DD</sub> = 5.0V	—	—	10 <sup>-3</sup>	μA
Analog output voltage	V <sub>OUT</sub>		—	0.50V <sub>DD</sub>	—	V <sub>p-p</sub>
Supply current	I <sub>DD</sub>	V <sub>DD</sub> = 5.0V	—	—	6	mA

## ■ OUTLINE DIMENSIONS

### YM3016-F

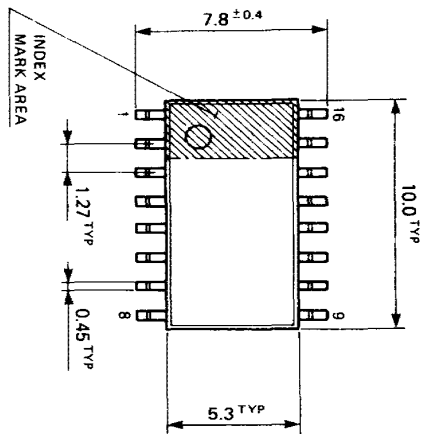

UNIT : MM

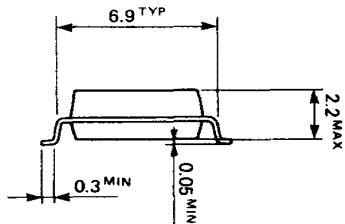

### YM3016-D

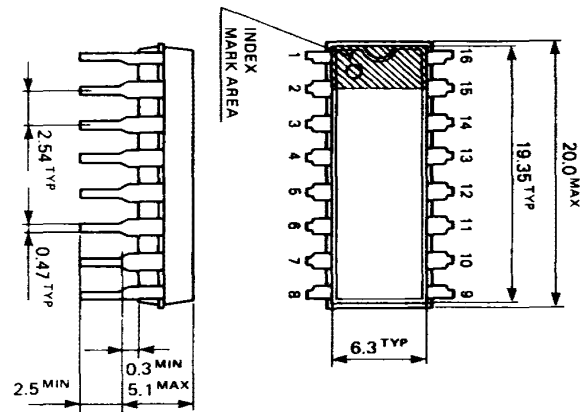

UNIT : MM

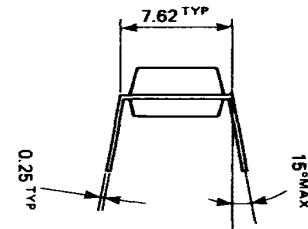

## ■ BLOCK DIAGRAM

