

SPECIFICATIONS

Prepared by	Approved by
王惠颖	牛红丽

CUSTOMER'S APPROVAL

APPROVED BY: _____ DATE: _____

DATE MAR.02.2018	Version	1.0	TECHNICAL SPECIFICATION
LCM			Page 1 of 25

REVISION HISTORY

Rev	Date	Item	Page	Remark
1.0	MER.02.2018	New Creation	ALL	

DATE MAR.02.2018	Version	1.0	TECHNICAL SPECIFICATION
LCM			Page 2 of 25

LIST

1. Over View	-----	(4)
2. Features	-----	(4)
3. Mechanical Specification	-----	(4)
4. Mechanical Drawing of EPD Module	-----	(5)
5. Input/output Pin Assignment	-----	(6-7)
6. Electrical Characteristics	-----	(8)
6.1 Absolute Maximum Rating	-----	(8)
6.2 Panel DC Characteristics	-----	(8-9)
6.3 Panel DC Characteristics(Driver IC Internal Regulators)	-----	(9)
6.4 Panel AC Characteristics	-----	(9)
6.4.1 MCU Interface Selection	-----	(9)
6.4.2 MCU Serial Interface (4-wire SPI)	-----	(9-10)
6.4.3 MCU Serial Interface (3-wire SPI)	-----	(11-12)
6.4.4 Interface Timing	-----	(12-13)
7. Command Table	-----	(14-17)
8. Optical Specification	-----	(18)
9. Handling, Safety, and Environment Requirements	-----	(18)
10. Reliability Test	-----	(19)
11. Block Diagram	-----	(20)
12. Typical Application Circuit with SPI Interface	-----	(20)
13. Typical Operating Sequence	-----	(21)
13.1 Normal Operation Flow	-----	(21)
13.2 Normal Operation Reference Program Code	-----	(22)
14. Part Number Definition	-----	(22)
15. Inspection condition	-----	(22)
15.1 Environment	-----	(22)
15.2 Illuminance	-----	(22)
15.3 Inspect method	-----	(23)
15.4 Display area	-----	(23)
15.5 Inspection standard	-----	(23)
15.5.1 Electric inspection standard	-----	(23-24)
15.5.2 Appearance inspection standard	-----	(24-25)
16. Packaging	-----	(25)

DATE MAR.02.2018	Version	1.0	TECHNICAL SPECIFICATION
LCM			Page 3 of 25

1. General Description

is an Active Matrix Electrophoretic Display (AM EPD), with interface and a reference system design. The 2.9inch active area contains 296×128 pixels. The module is a TFT-array driving electrophoresis display, with integrated circuits including gate driver, source driver, MCU interface, timing controller, oscillator, DC-DC, SRAM, LUT, VCOM. Module can be used in portable electronic devices, such as Electronic Shelf Label (ESL) System.

2.Features

- 296×128 pixels display
- High contrast High reflectance
- Ultra wide viewing angle Ultra low power consumption
- Pure reflective mode
- Bi-stable display
- Commercial temperature range
- Landscape portrait modes
- Hard-coat antiglare display surface
- Ultra Low current deep sleep mode
- On chip display RAM
- Waveform can stored in On-chip OTP or written by MCU
- Serial peripheral interface available
- On-chip oscillator
- On-chip booster and regulator control for generating VCOM, Gate and Source driving voltage
- I2C signal master interface to read external temperature sensor
- Built-in temperature sensor
- With black white, red display color

3. Mechanical Specifications

Parameter	Specifications	Unit	Remark
Screen Size	2.9	Inch	
Display Resolution	128(H)×296(V)	Pixel	DPI:112
Active Area	29.06×66.90	mm	
Pixel Pitch	0.227×0.226	mm	
Pixel Configuration	Rectangle		
Outline Dimension	36.7(H)×79.0 (V) ×1.20(D)	mm	
Weight	5.5±0.5	g	

DATE MAR.02.2018	Version	1.0	TECHNICAL SPECIFICATION
LCM			Page 4 of 25

4. Mechanical Drawing of EPD module

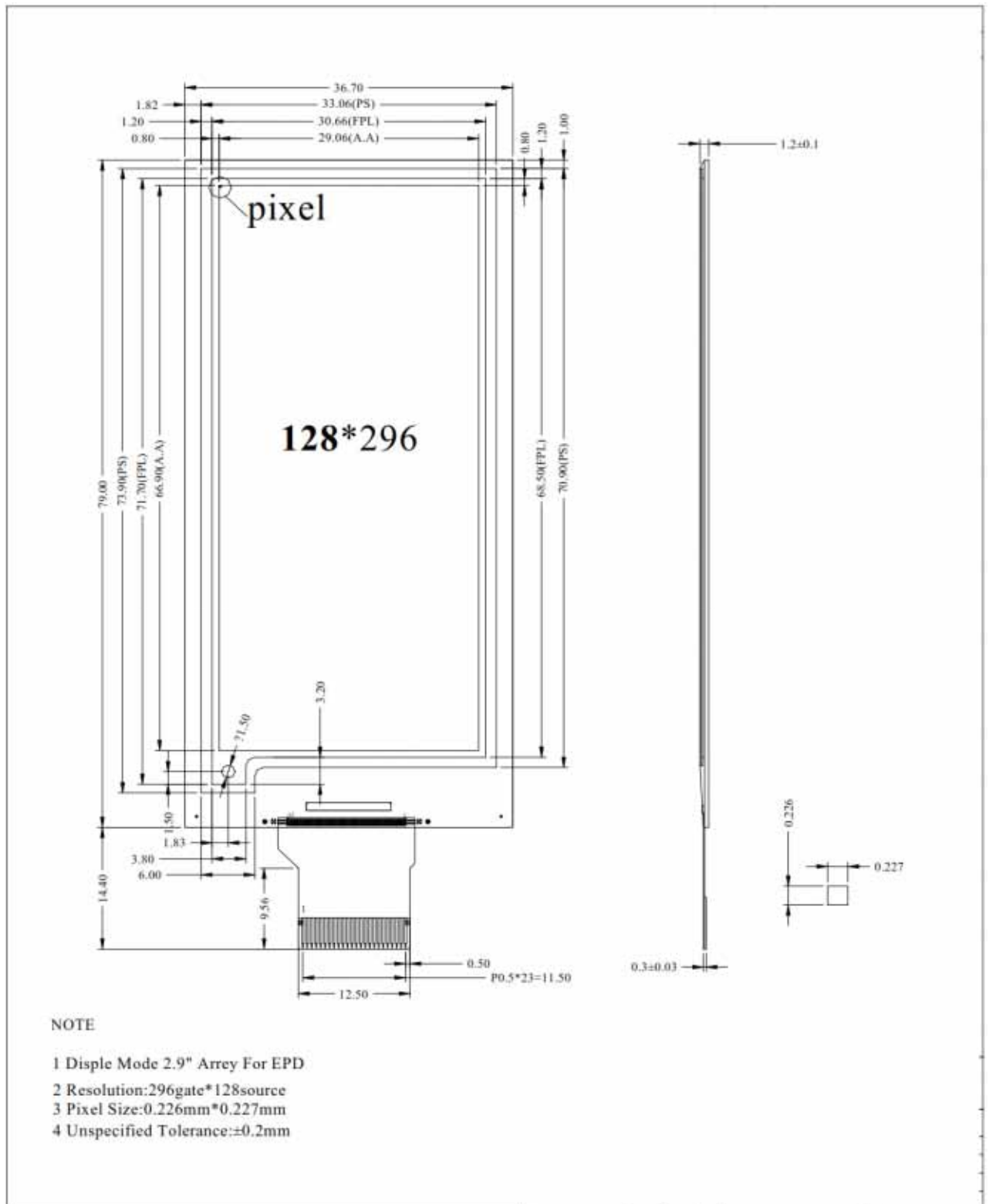

DATE MAR.02.2018	Version	1.0	TECHNICAL SPECIFICATION
LCM			Page 5 of 25

5. Input / Output Terminals

No.	Name	I/O	Description	Remark
1	NC		Do not connect with other NC pins	Keep Open
2	GDR	O	N-Channel MOSFET Gate Drive Control	
3	RESE	I	Current Sense Input for the Control Loop	
4	NC	NC	Do not connect with other NC pins	Keep Open
5	VSH2	NC	Positive Source driving voltage	
6	TSCL	O	I2C Interface to digital temperature sensor Clock pin	
7	TSDA	I/O	I2C Interface to digital temperature sensor Data pin	
8	BS1	I	Bus Interface selection pin	Note 5-5
9	BUSY	O	Busy state output pin	Note 5-4
10	RES#	I	Reset signal input. Active Low.	Note 5-3
11	D/C#	I	Data /Command control pin	Note 5-2
12	CS#	I	Chip select input pin	Note 5-1
13	SCL	I	Serial Clock pin (SPI)	
14	SDA	I	Serial Data pin (SPI)	
15	VDDIO	P	Power Supply for interface logic pins It should be connected with VCI	
16	VCI	P	Power Supply for the chip	
17	VSS	P	Ground	
18	VDD	C	Core logic power pin VDD can be regulated internally from VCI. A capacitor should be connected between VDD and VSS	
19	VPP	P	FOR TEST	Keep Open
20	VSH1	C	Positive Source driving voltage	
21	VGH	C	Power Supply pin for Positive Gate driving voltage and VSH1	
22	VSL	C	Negative Source driving voltage	
23	VGL	C	Power Supply pin for Negative Gate driving voltage VCOM and VSL	
24	VCOM	C	VCOM driving voltage	

DATE MAR.02.2018

Version

1.0

TECHNICAL SPECIFICATION

LCM

Page 6 of 25

I = Input Pin, O =Output Pin, /O = Bi-directional Pin (Input/output), P = Power Pin, C = Capacitor Pin

Note 5-1: This pin (CS#) is the chip select input connecting to the MCU. The chip is enabled for MCU communication only when CS# is pulled LOW.

Note 5-2: This pin is (D/C#) Data/Command control pin connecting to the MCU in 4-wire SPI mode. When the pin is pulled HIGH, the data at SDA will be interpreted as data. When the pin is pulled LOW, the data at SDA will be interpreted as command.

Note 5-3: This pin (RES#) is reset signal input. The Reset is active low.

Note 5-4: This pin is Busy state output pin. When Busy is High, the operation of chip should not be interrupted, command should not be sent. The chip would put Busy pin High when -Outputting display waveform -Communicating with digital temperature sensor

Note 5-5: Bus interface selection pin

BS1 State	MCU Interface
L	4-lines serial peripheral interface(SPI) - 8 bits SPI
H	3- lines serial peripheral interface(SPI) - 9 bits SPI

DATE MAR.02.2018

Version

1.0

TECHNICAL SPECIFICATION

LCM

Page 7 of 25

6. Electrical Characteristics

6.1 Absolute Maximum Ratings

Parameter	Symbol	Rating	Unit
Logic supply voltage	V _{CI}	-0.5 to +4.0	V
Logic Input voltage	V _{IN}	-0.5 to V _{CI} +0.5	V
Logic Output voltage	V _{OUT}	-0.5 to V _{CI} +0.5	V
Operating Temp range	TOPR	0 to +40	°C.
Storage Temp range	TSTG	-25 to +70	°C.

Note:

1. Maximum ratings are those values beyond which damages to the device may occur. Functional operation should be restricted to the limits in the Panel DC Characteristics tables.
2. Optimal operating temperature range: 0-30°C (@1pixel) 30~70%RH
3. The optimal storage environment: 23 ± 2°C 55 ± 10%RH

6.2 Panel DC Characteristics

The following specifications apply for: V_{SS}=0V, V_{CI}=3.0V, TOPR =25°C.

Parameter	Symbol	Condition	Applicable pin	Min.	Typ.	Max.	Unit
Single ground	V _{SS}	-		-	0	-	V
Logic supply voltage	V _{CI}	-	V _{CI}	2.2	3.0	3.7	V
Core logic voltage	V _{DD}		V _{DD}	1.7	1.8	1.9	V
High level input voltage	V _{IH}	-	-	0.8 V _{CI}	-	-	V
Low level input voltage	V _{IL}	-	-	-	-	0.2 V _{CI}	V
High level output voltage	V _{OH}	I _{OH} = -100uA	-	0.9 V _{CI}	-	-	V
Low level output voltage	V _{OL}	I _{OL} = 100uA	-	-	-	0.1 V _{CI}	V
Typical power	P _{TYP}	V _{CI} =3.0V	-	-	12.9	13.5	mW
Deep sleep mode	P _{STPY}	V _{CI} =3.0V	-	-	0.003	-	mW
Typical operating current	I _{opr_VCI}	V _{CI} =3.0V	-	-	4.3	4.5	mA
Image update time	-	25 °C	-	-	12	15	sec
Sleep mode current	I _{slp_VCI}	DC/DC off No clock No input load Ram data retain	-	-	20		uA
Deep sleep mode current	I _{dslp_VCI}	DC/DC off No clock No input load Ram data not retain	-	-	1	5	uA

Notes: 1. The typical power is measured with following transition from horizontal 2 scale pattern to vertical 2 scale pattern.

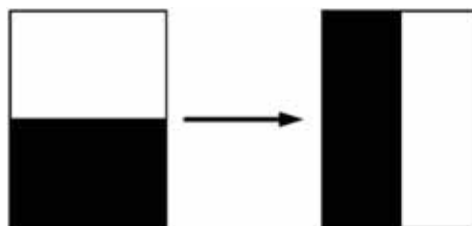

DATE MAR.02.2018	Version	1.0	TECHNICAL SPECIFICATION
LCM			Page 8 of 25

2. The deep sleep power is the consumed power when the panel controller is in deep sleep mode.
3. The listed electrical/optical characteristics are only guaranteed under the controller & waveform provided by YES

6.3 Panel DC Characteristics(Driver IC Internal Regulators)

The following specifications apply for: VSS=0V, VCI=3.0V, TOPR =25°C.

Parameter	Symbol	Condition	Applicable pin	Min.	Typ.	Max.	Unit
VCOM output voltage	VCOM	-	VCOM	-2.5	-2	-1.5	V
Positive Source output voltage	V _{SH}	-	S ₀ ~S ₁₂₇	+14.5	+15	+15.5	V
Negative Source output voltage	V _{SL}	-	S ₀ ~S ₁₂₇	-15.5	-15	-14.5	V
Positive gate output voltage	V _{gh}	-	G ₀ ~G ₂₉₅	+21	+22	+23	V
Negative gate output voltage	V _{gl}	-	G ₀ ~G ₂₉₅	-21	-20	-19	V

6.4 Panel AC Characteristics

6.4.1 MCU Interface Selection

The pin assignment at different interface mode is summarized in Table 6-4-1. Different MCU mode can be set by hardware selection on BS1 pins. The display panel only supports 4-wire SPI or 3-wire SPI interface mode.

Pin Name	Data/Command Interface		Control Signal		
Bus interface	SDA	SCL	CS#	D/C#	RES#
BS1=L 4-wire SPI	SDA	SCL	CS#	D/C#	RES#
BS1=H 3-wire SPI	SDA	SCL	CS#	L	RES#

6.4.2 MCU Serial Interface (4-wire SPI)

The serial interface consists of serial clock SCL, serial data SDA, D/C#, CS#. This interface supports Write mode and Read mode.

Function	CS#	D/C#	SCL
Write command	L	L	↑
Write data	L	H	↑

Note: ↑ stands for rising edge of signal

In the write mode SDA is shifted into an 8-bit shift register on every rising edge of SCL in the order of D7, D6, ... D0. The level of D/C# should be kept over the whole byte. The data byte in the shift register is written to the Graphic Display Data RAM /Data Byte register or command Byte register according to D/C# pin.

DATE MAR.02.2018	Version	1.0	TECHNICAL SPECIFICATION
LCM			Page 9 of 25

Figure 6-1: Write procedure in 4-wire SPI mode

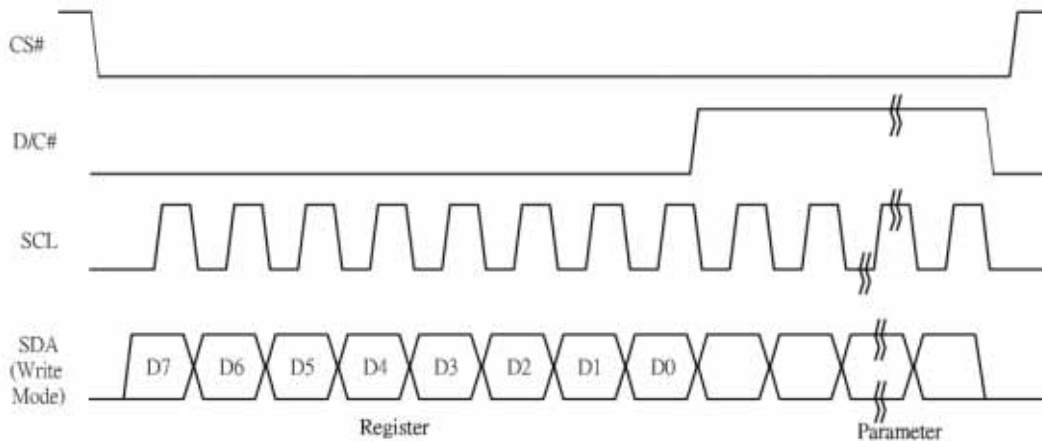

In the Read mode:

1. After driving CS# to low, MCU need to define the register to be read.
2. SDA is shifted into an 8-bit shift register on every rising edge of SCL in the order of D7, D6, ... D0 with D/C# keep low.
3. After SCL change to low for the last bit of register, D/C# need to drive to high.
4. SDA is shifted out an 8-bit data on every falling edge of SCL in the order of D7, D6, ...D0.
5. Depending on register type, more than 1 byte can be read out. After all byte are read, CS# need to drive to high to stop the read operation.

Figure 6-2: Read procedure in 4-wire SPI mode

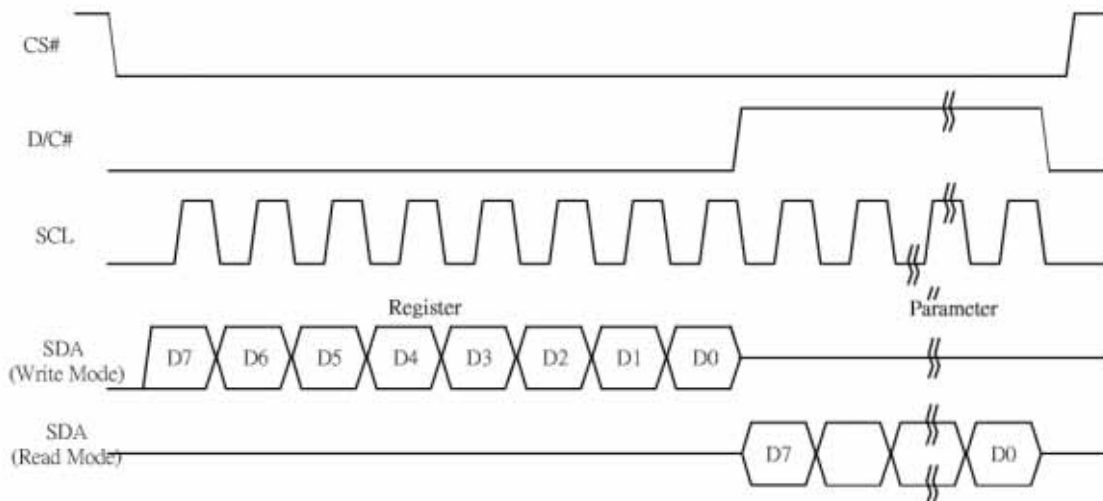

DATE MAR.02.2018	Version	1.0	TECHNICAL SPECIFICATION
LCM			Page 10 of 25

6.4.3 MCU Serial Interface (3-wire SPI)

The 3-wire serial interface consists of serial clock SCL, serial data SDA and CS#. This interface also supports Write mode and Read mode.

The operation is similar to 4-wire serial interface while D/C# pin is not used. There are altogether 9-bits will be shifted into the shift register on every ninth clock in sequence: D/C# bit, D7 to D0 bit. The D/C# bit (first bit of the sequential data) will determine the following data byte in the shift register is written to the Display Data RAM (D/C# bit = 1) or the command register (D/C#bit = 0).

Function	CS#	D/C#	SCL
Write command	L	Tie	↑
Write data	L	Tie	↑

Note: ↑ stands for rising edge of signal

Figure 6-3: Write procedure in 3-wire SPI mode

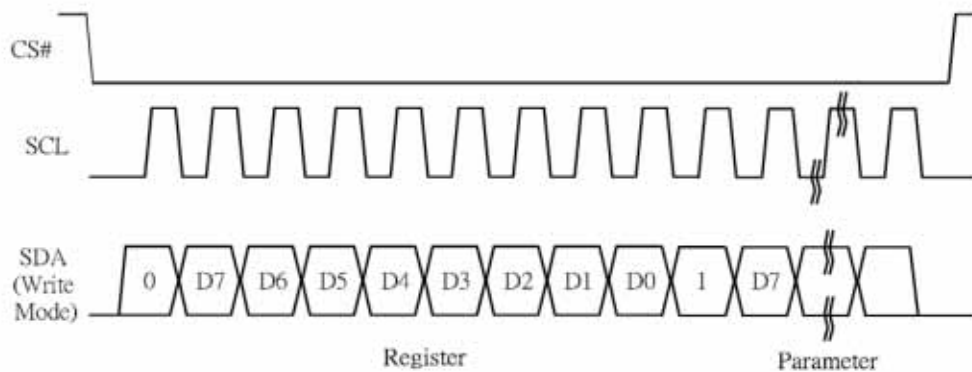

In the Read mode:

1. After driving CS# to low, MCU need to define the register to be read.
2. D/C=0 is shifted thru SDA with one rising edge of SCL
3. SDA is shifted into an 8-bit shift register on every rising edge of SCL in the order of D7, D6, ... D0.
4. D/C=1 is shifted thru SDA with one rising edge of SCL
5. SDA is shifted out an 8-bit data on every falling edge of SCL in the order of D7, D6, ...D0.
6. Depending on register type, more than 1 byte can be read out. After all byte are read, CS# need to drive to high to stop the read operation.

DATE MAR.02.2018	Version	1.0	TECHNICAL SPECIFICATION
LCM			Page 11 of 25

Figure 6-4: Read procedure in 3-wire SPI mode

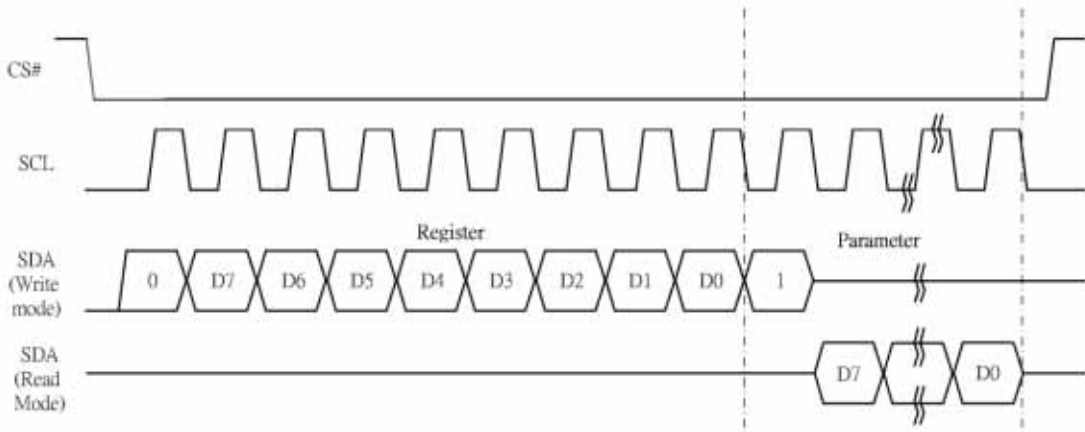

6.4.4 Interface Timing

The following specifications apply for: $V_{SS}=0V$, $V_{CI}=3.0V$, $T_{OPR}=25^{\circ}C$.

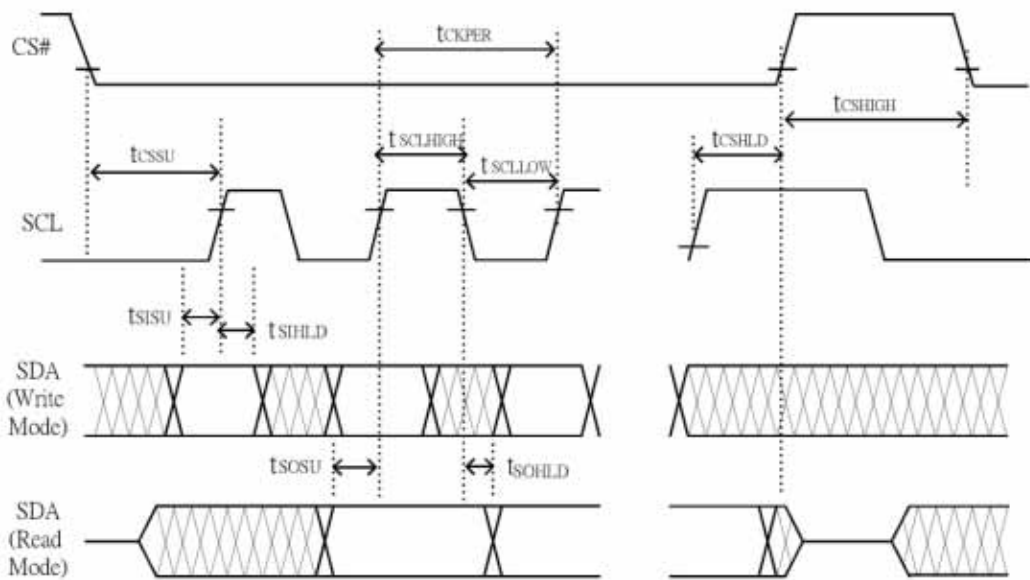

Changed Diagram

DATE MAR.02.2018	Version	1.0	TECHNICAL SPECIFICATION
LCM			Page 12 of 25

Serial Interface Timing Characteristics

(VCI - VSS = 2.2V to 3.7V, TOPR = 25°C, CL=20pF)

Write mode

Symbol	Parameter	Min	Typ.	Max	Unit
fSCL	SCL frequency (Write Mode)			20	MHz
tCSSU	Time CS# has to be low before the first rising edge of SCLK	20			ns
tCSHLD	Time CS# has to remain low after the last falling edge of SCLK	20			ns
tCSHIGH	Time CS# has to remain high between two transfers	100			ns
tSCLHIGH	Part of the clock period where SCL has to remain high	25			ns
tSCLLOW	Part of the clock period where SCL has to remain low	25			ns
tSISU	Time SI (SDA Write Mode) has to be stable before the next rising edge of SCL	10			ns
tSIHLD	Time SI (SDA Write Mode) has to remain stable after the rising edge of SCL	40			ns

Read mode

Symbol	Parameter	Min	Typ.	Max	Unit
fSCL	SCL frequency (Read Mode)			2.5	MHz
tCSSU	Time CS# has to be low before the first rising edge of SCLK	100			ns
tCSHLD	Time CS# has to remain low after the last falling edge of SCLK	50			ns
tCSHIGH	Time CS# has to remain high between two transfers	250			ns
tSCLHIGH	Part of the clock period where SCL has to remain high	180			ns
tSCLLOW	Part of the clock period where SCL has to remain low	180			ns
tSOSU	Time SO(SDA Read Mode) will be stable before the next rising edge of SCL		50		ns
tSOHLD	Time SO (SDA Read Mode) will remain stable after the rising edge of SCL		70		ns

DATE MAR.02.2018

Version

1.0

TECHNICAL SPECIFICATION

LCM

Page 13 of 25

7.Command Table

R/W#	D/C#	Hex	D7	D6	D5	D4	D3	D2	D1	D0	Command	Description	
0	0	01	0	0	0	0	0	0	0	1	Driver Output control	Gate setting Set A[8:0]=0127h Set B[8:0]=00h	
0	1		A7	A6	A5	A4	A3	A2	A1	A0			
0	1		0	0	0	0	0	0	0	A8			
0	1		0	0	0	0	0	B2	B1	B0			
0	0	03	0	0	0	0	0	0	1	1	Gate Driving voltage control	SetGate Driving voltage A[4:0]=17h[POR],VGH at 20V[POR] VGH setting from 10V to 21V	
0	1		0	0	0	A4	A3	A2	A1	A0			
0	0	04	0	0	0	0	0	1	0	0	Source Driving voltage control	SetSource Driving voltage A[7:0]= 41h[POR],VSH1 at 15V B[7:0]=A Ch[POR],VSH2 at 5.4V C[7:0]= 32h[POR], VSL at -15V	
0	1		A7	A6	A5	A4	A3	A2	A1	A0			
0	1		B7	B6	B5	B4	B3	B2	B1	B0			
0	1		C7	C6	C5	C4	C3	C2	C1	C0			
0	0	10	0	0	0	1	0	0	0	0	Deep Sleep mode	Deep Sleep mode Control	
0	1		0	0	0	0	0	0	0	A ₀		A[0] :	Description
												0	Normal Mode [POR]
												1	Enter Deep Sleep Mode
0	0	11	0	0	0	1	0	0	0	1	Data Entry mode setting	Define data entry sequence A [1:0] = ID[1:0]Address automatic increment / decrement setting The setting of incrementing or decrementing of the address counter can be made independently in each upper and lower bit of the address. 00 –Y decrement, X decrement, 01 –Y decrement, X increment, 10 –Y increment, X decrement, 11 –Y increment, X increment [POR] A[2] = AM Set the direction in which the address counter is updated automatically after data are written to the RAM. AM= 0, the address counter is updated in the X direction. [POR] AM = 1, the address counter is updated in the Y direction.	
0	1		0	0	0	0	0	A ₂	A ₁	A ₀			
0	0	12	0	0	0	1	0	0	1	0	SWRESET	It resets the commands and parameters to their S/W Reset default values except R10h-Deep Sleep Mode Note: RAM are unaffected by this command.	
0	0	18	0	0	0	1	1	0	0	0	Temperature Sensor Control	Temperature Sensor Selection A[7:0] = 48h [POR], external temperature sensor A[7:0] = 80h Internal temperature sensor	
0	1		A7	A6	A5	A4	A3	A2	A1	A0			

DATE MAR.02.2018

Version

1.0

TECHNICAL SPECIFICATION

LCM

Page 14 of 25

0	0	1A	0	0	0	1	1	0	1	0	Temperature Sensor Control (Write to temperature register)	Write to temperature register. A[7:0] – MS Byte 01111111[POR] B[7:0] – LS Byte 11110000[POR]
0	1		A7	A6	A5	A4	A3	A2	A1	A0		
0	1		B7	B6	B5	B4	0	0	0	0		
0	0	20	0	0	1	0	0	0	0	0	Master Activation	Activate Display Update Sequence The Display Update Sequence Option is located at R22h User should not interrupt this operation to avoid corruption of panel images.
0	0	21	0	0	1	0	0	0	0	1	Display Update Control 1	RAM content option for Display Update BW RAM option A[7:4]=0100 (For BW) A[3:0]=0000[POR] Normal A[3:0]=0100 Bypass RAM content as 0 A[3:0]=0100 Inverse RAM content
0	1		0	0	0	0	A3	A2	A1	A0		
0	0	22	0	0	1	0	0	0	1	0	Display Update Control 2	Display Update Sequence Option: Enable the stage for Master Activation
	1		A7	A6	A5	A4	A3	A2	A1	A0		Setting for LUT from MCU
												Enable Clock Signal, Then Enable Analog Then PATTERN DISPLAY C7 Then Disable Analog Then Disable OSC
												Setting for LUT from OTP according to external Temperature Sensor operation
												Then Enable Analog Then Load LUT
											Enable Analog Then PATTERN DISPLAY Then Disable Analog Then Disable OSC	47
0	0	24	0	0	1	0	0	1	0	0	Write RAM (BW)	After this command, data entries will be written into the IRAM until another command is written. Address pointers will advance accordingly. For Write pixel: Content of write RAM(BW)=1 For Black pixel: Content of write RAM(BW)=0

DATE MAR.02.2018	Version	1.0	TECHNICAL SPECIFICATION
LCM			Page 15 of 25

0	0	26	0	0	1	0	0	1	1	0	Write RAM (RED)	After this command, data entries will be written into the 2 RAM until another command is written. Address pointers will advance accordingly. For RED pixel: Content of write RAM(RED)=1 For White/Black pixel: Content of write RAM(RED)=0		
0	0	2C	0	0	1	0	1	1	0	0	Write VCOM register	Set A[7:0]=2Fh		
0	1		A7	A6	A5	A4	A3	A2	A1	A0				
0	0	2D	0	0	1	0	1	1	0	1	OTP Register Read	Read Register stored in OTP: 1. A[7:0]~ B[7:0]: VCOM Information 3. C[7:0]~F[7:0]: Reserved 4. G[7:0]~H[7:0]: Module ID/ Waveform Version [2bytes]		
1	1		A7	A6	A5	A4	A3	A2	A1	A0				
1	1		B7	B6	B5	B4	B3	B2	B1	B0				
1	1		C7	C6	C5	C4	C3	C2	C1	C0				
1	1		D7	D6	D5	D4	D3	D2	D1	D0				
1	1		E7	E6	E5	E4	E3	E2	E1	E0				
1	1		F7	F6	F5	F4	F3	F2	F1	F0				
1	1		G7	G6	G5	G4	G3	G2	G1	G0				
1	1		H7	H6	H5	H4	H3	H2	H1	H0				
0	0	2F	0	0	1	0	1	1	1	1			Status Bit Read	Read IC status Bit [POR 0x21] A[5]: HV Ready Detection flag [POR=1] 0: Ready 1: Not Ready A[4]: VCI Detection flag [POR=0] 0: Normal 1: VCI lower than the Detect level A[3]: [POR=0] A[2]: Busy flag [POR=0] 0: Normal 1: BUSY A[1:0]: Chip ID [POR=01] Remark: A[5] and A[4] status are not valid after RESET, they need to be initiated by command 0x14 and command 0x15 respectively.
1	1		0	0	A5	A4	0	0	A1	A0				
0	0	32	0	0	1	1	0	0	1	0	Write LUT register	Write LUT register from MCU interface [70 bytes].		
0	1		A7	A6	A5	A4	A3	A2	A1	A0				
0	1		B7	B6	B5	B4	B3	B2	B1	B0				
0	1		:	:	:	:	:	:	:	:				
0	1		:	:	:	:	:	:	:	:				
0	1		:	:	:	:	:	:	:	:				
0	1		:	:	:	:	:	:	:	:				

DATE MAR.02.2018	Version	1.0	TECHNICAL SPECIFICATION
LCM			Page 16 of 25

0	0	3A	0	0	1	1	1	0	1	0	Set dummy line period	Set A[6:0]=30h Default value will give 50Hz Frame frequency
0	1		0	A ₆	A ₅	A ₄	A ₃	A ₂	A ₁	A ₀		
0	0	3B	0	0	1	1	1	0	1	1	Set Gate line width	Set A[3:0]=0Ah Default value will give 50Hz Frame frequency
0	1		0	0	0	0	A ₃	A ₂	A ₁	A ₀		
0	0	3C	0	0	1	1	1	1	0	0	Border Waveform Control	Select border waveform for VBD A [7:6] Select VBD
0	1		A ₇	A ₆	A ₅	A ₄	0	0	A ₁	A ₀		
												A [7:6] Select VBD as
												00[POR] GS Transition Define A[1:0]
												01 Fix Level Define A [5:4]
												10 VCOM
												11 HIZ
												A [5:4] Fix Level Setting for VBD
												A[5:4] VBD level
												00[POR] VSS
												01 VSH1
												10 VSL
												11 VSH2
												A[1:0] BW Transition setting for VBD
												A[1:0] VBD Transition
												00 [POR] LUT0
												01 LUT1
												10 LUT2
												11 LUT3
0	0	44	0	1	0	0	0	1	0	0	Set RAM X - address Start / End position	Specify the start/end positions of the window address in the X direction by an address unit A[4:0]: XSA[4:0], X Start, POR = 00h B[4:0]: XEA[4:0], X End, POR = 0Fh
0	1		0	0	0	A ₄	A ₃	A ₂	A ₁	A ₀		
0	1		0	0	0	B ₄	B ₃	B ₂	B ₁	B ₀		
0	0	45	0	1	0	0	0	1	0	1	Set Ram Y- address Start / End position	Specify the start/end positions of the window address in the Y direction by an address unit A[8:0]: YSA[8:0], Y Start, POR = 0127h B[8:0]: YEA[8:0], Y End, POR = 0000h
0	1		A ₇	A ₆	A ₅	A ₄	A ₃	A ₂	A ₁	A ₀		
0	1		0	0	0	0	0	0	0	A ₈		
0	1		B ₇	B ₆	B ₅	B ₄	B ₃	B ₂	B ₁	B ₀		
0	1		0	0	0	0	0	0	0	B ₈		
0	0	4E	0	1	0	0	1	1	1	0	Set RAM X address counter	Make initial settings for the RAM X address in the address counter (AC) A[4:0]: XAD[4:0], POR is 00h
0	1		0	0	0	A ₄	A ₃	A ₂	A ₁	A ₀		
0	0	4F	0	1	0	0	1	1	1	1	Set RAM Y address counter	Make initial settings for the RAM Y address in the address counter (AC) A[8:0]: YAD8:0], POR is 0127h
0	1		A ₇	A ₆	A ₅	A ₄	A ₃	A ₂	A ₁	A ₀		
0	1		0	0	0	0	0	0	0	A ₈		
0	0	74	0	1	1	1	0	1	0	0	Set Analog Block control	A[7:0] = 54h
0	1		A ₇	A ₆	A ₅	A ₄	A ₃	A ₂	A ₁	A ₀		
0	0	7E	0	1	1	1	1	1	1	0	Set Digital Block control	A[7:0] = 3Bh
0	1		A ₇	A ₆	A ₅	A ₄	A ₃	A ₂	A ₁	A ₀		

DATE MAR.02.2018

Version

1.0

TECHNICAL SPECIFICATION

LCM

Page 17 of 25

8. Optical Specification

Measurements are made with that the illumination is under an angle of 45 degree, the detection is perpendicular unless otherwise specified

Symbol	Parameter	Conditions	Min	Typ.	Max	Units	Notes
R	White Reflectivity	White	30	35	-	%	8-1
CR	Contrast Ratio	indoor	8:1		-		8-2
GN	2Grey Level	-	-	DS+(WS-DS)*n(m-1)			8-3
T update	Image update time	at 25 °C	-	12	-	sec	
Life		0°C-40°C		1000000times or 5years			

Notes: 8-1. Luminance meter: Eye-One Pro Spectrophotometer.

8-2. CR=Surface Reflectance with all white pixel/Surface Reflectance with all black pixels.

8-3 WS: White state, DS: Dark state

9. Handling, Safety and Environmental Requirement

Warning

The display glass may break when it is dropped or bumped on a hard surface. Handle with care. Should the display break, do not touch the electrophoretic material. In case of contact with electrophoretic material, wash with water and soap.

Caution

The display module should not be exposed to harmful gases, such as acid and alkali gases, which corrode electronic components. Disassembling the display module.

Disassembling the display module can cause permanent damage and invalidates the warranty agreements.

Observe general precautions that are common to handling delicate electronic components. The glass can break and front surfaces can easily be damaged. Moreover the display is sensitive to static electricity and other rough environmental conditions.

Data sheet status	
Product specification	This data sheet contains final product specifications.
Limiting values	
Limiting values given are in accordance with the Absolute Maximum Rating System (IEC 134). Stress above one or more of the limiting values may cause permanent damage to the device. These are stress ratings only and operation of the device at these or at any other conditions above those given in the Characteristics sections of the specification is not implied. Exposure to limiting values for extended periods may affect device reliability.	
Application information	
Where application information is given, it is advisory and does not form part of the specification.	

DATE MAR.02.2018	Version	1.0	TECHNICAL SPECIFICATION
LCM			Page 18 of 25

10. Reliability test

NO	Test items	Test condition
1	Low-Temperature Storage	T = -25°C, 240 h Test in white pattern
2	High-Temperature Storage	T=60°C, RH=35%, 240h Test in white pattern
3	High-Temperature Operation	T=40°C, RH=35%, 240h
4	Low-Temperature Operation	0°C, 240h
5	High-Temperature, High-Humidity Operation	T=40°C, RH=80%, 168h
6	High Temperature, High Humidity Storage	T=50°C, RH=80%, 240h Test in white pattern
7	Temperature Cycle	1 cycle:[-25°C 30min]→[+60 °C 30 min] : 50 cycles Test in white pattern
8	UV exposure Resistance	765W/m ² for 168hrs,40 °C Test in white pattern
9	ESD Gun	Air+/-15KV;Contact+/-8KV (Test finished product shell,not display only) Air+/-8KV;Contact+/-6KV (Naked EPD display,no including IC and FPC area) Air+/-4KV;Contact+/-2KV (Naked EPD display,including IC and FPC area)

Note: Put in normal temperature for 1hour after test finished, display performance is ok.

DATE MAR.02.2018	Version	1.0	TECHNICAL SPECIFICATION
LCM			Page 19 of 25

11. Block Diagram

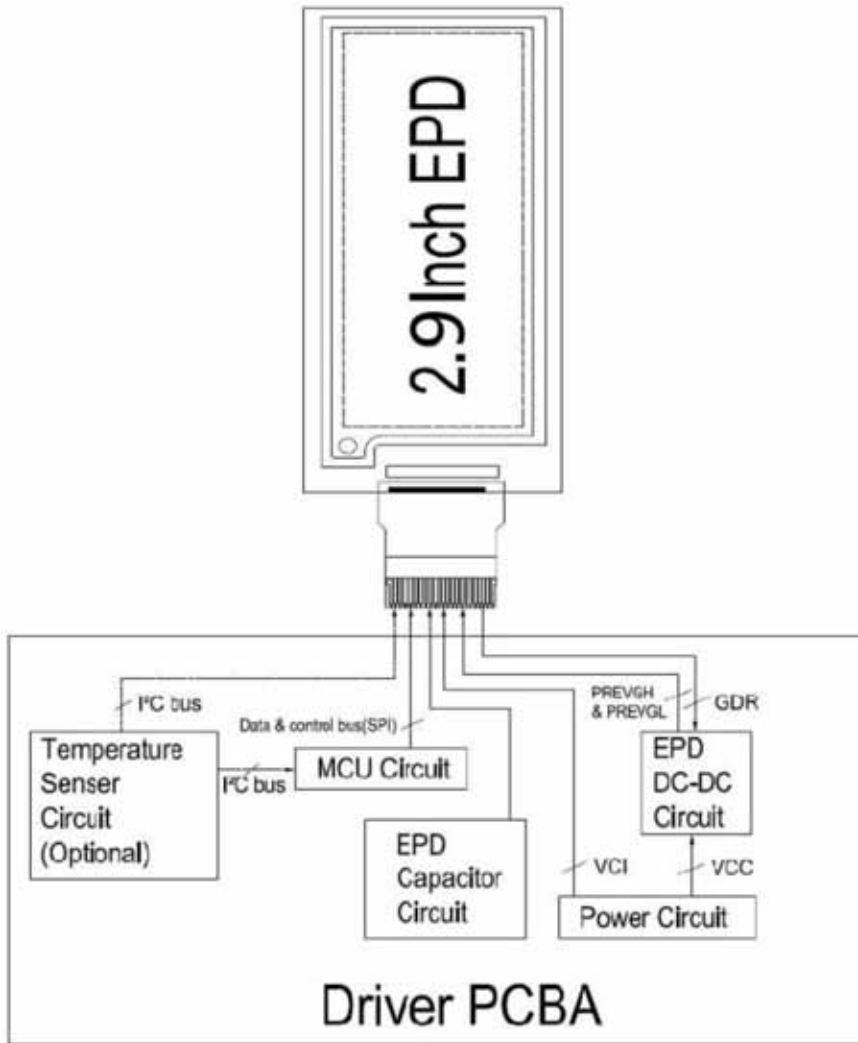

12. Typical Application Circuit with SPI Interface

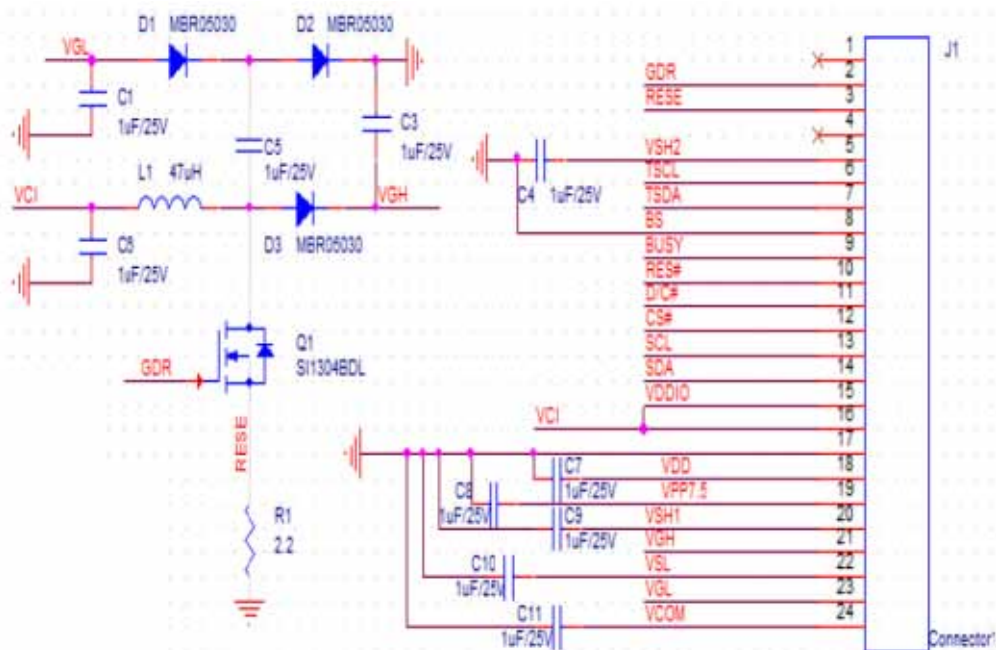

DATE MAR.02.2018

Version

1.0

TECHNICAL SPECIFICATION

LCM

Page 20 of 25

13 Typical Operating Sequence

13.1 Normal Operation Flow

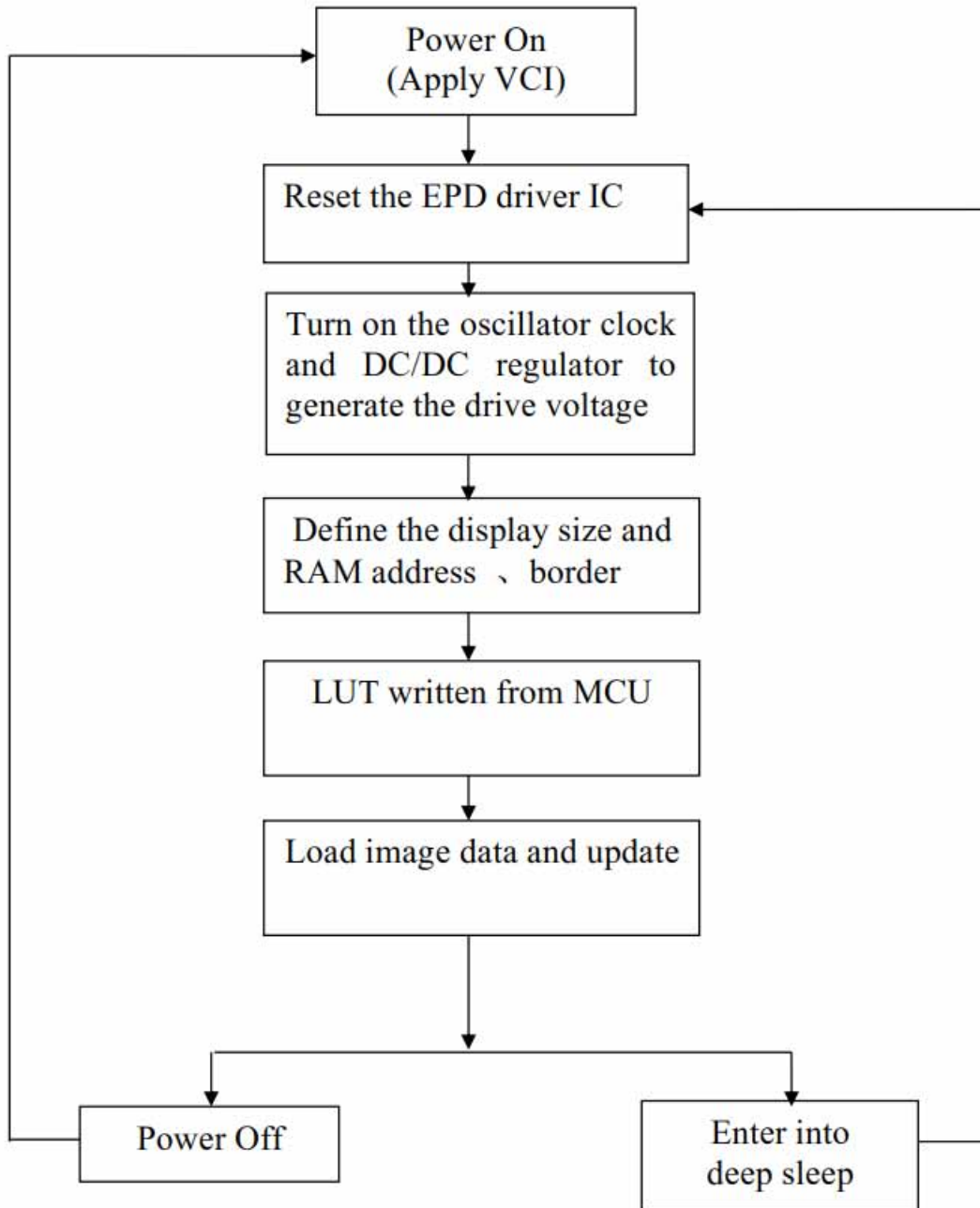

13.2 Normal Operation Reference Program Code

ACTION	VALUE/DATA	COMMENT
POWER ON		
delay	10ms	
PIN CONFIG		
RESE#	high	Hardware reset
delay	200us	
RESE#	low	
delay	200us	
Read busy pin		Wait for busy low
Command 0x12		Software reset
Read busy pin		Wait for busy low
Command 0x74	Data 0x54	Set Analog Block Control
Command 0x7E	Data 0x3B	Set Digital Block Control
Command 0x01	Data 0x27 0x01 0x00	Set display size and driver output control
Command 0x11	Data 0x01	Ram data entry mode
Command 0x44	Data 0x00 0x0F	Set Ram X address
Command 0x45	Data 0x27 0x01 0x00 0x00	Set Ram Y address
Command 0x3C	Data 0x01	Set border
SET VOLTAGE AND LOAD LUT		
Command 0x2C	Data 0x2F	Set VCOM value
Command 0x03	Data 0x17	Gate voltage setting
Command 0x04	Data 0x41 0xAC 0x32	Source voltage setting
Command 0x3A	Data 0x30	Frame setting 50hz
Command 0x3B	Data 0x0A	
Command 0x32	Write 70bytes LUT	Load LUT
LOAD IMAGE AND UPDATE		
Command 0x4E	Data 0x00	Set Ram X address counter
Command 0x4F	Data 0x27 0x01	Set Ram Y address counter
Command 0x24	4736bytes	Load BW image (128/8*296)
Command 0x4E	Data 0x00	Set Ram X address counter
Command 0x4F	Data 0x27 0x01	Set Ram Y address counter
Command 0x26	4736bytes	Load RED image (128/8*296)
Command 0x22	Data 0XC7	Image update
Command 0x20		
Read busy pin		Wait for busy low
Command 0x10	Data 0X01	Enter deep sleep mode
POWER OFF		

14. Part Number Definition

TBD

15. Inspection condition

15.1 Environment

Temperature: 25±3°C

Humidity: 55±10%RH

15.2 Illuminance

Brightness: 1200~1500LUX; distance: 20-30CM; Angle: Relate 30°surround.

DATE MAR.02.2018	Version	1.0	TECHNICAL SPECIFICATION
LCM			Page 22 of 25

15.3 Inspect method

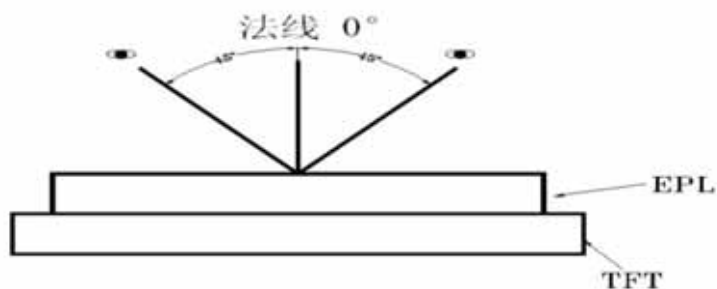

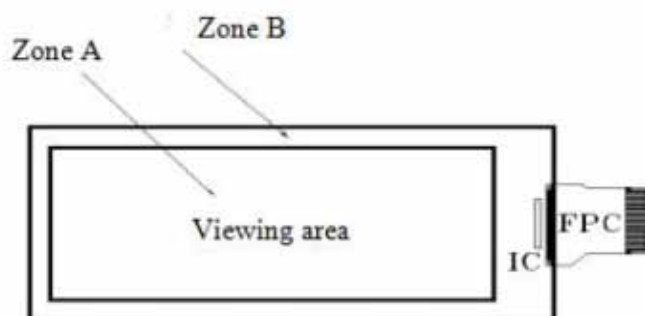

15.4 Display area

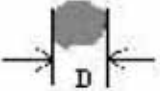

15.5 Inspection standard

15.5.1 Electric inspection standard

NO.	Item	Standard	Defect level	Method	Scope
1	Display	Display complete Display uniform	MA	Visual inspection	Zone A
2	Black/White spots	 $D \leq 0.25\text{mm}$, Allowed $0.25\text{mm} < D \leq 0.4\text{mm}$, $N \leq 3$, and Distance $\geq 5\text{mm}$ $0.4\text{mm} < D$ Not Allow	MI		
3	Black/White spots (No switch)	 $L \leq 0.6\text{mm}$, $W \leq 0.2\text{mm}$, $N \leq 1$ $L \leq 2.0\text{mm}$, $W > 0.2\text{mm}$, Not Allow $L > 0.6\text{mm}$, Not Allow			
4	Ghost image	Allowed in switching process	MI		

DATE MAR.02.2018

Version

1.0





TECHNICAL SPECIFICATION

LCM

Page 23 of 25

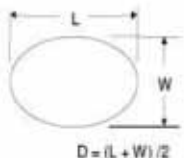
5	Flash spots/ Larger FPL size	Flash spots in switching, Allowed FPL size larger than viewing area, Allowed	MI	Visual/ Inspection card	Zone A Zone B
6	Display wrong/Missing	All appointed displays are showed correct	MA	Visual inspection	Zone A
6	Short circuit/ Circuit break/ Display abnormal	Not Allow			

15.5.2 Appearance inspection standard

NO.	Item	Standard	Defect level	Method	Scope
1	B/W spots /Bubble/ Foreign bodies/ Dents	 $D = (L + W) / 2$ <p>D ≤ 0.25mm, Allowed 0.25mm < D ≤ 0.4mm, N ≤ 3 D > 0.4mm, Not Allow</p>	MI	Visual inspection	Zone A
2	Glass crack	Not Allow	MA	Visual / Microscope	Zone A Zone B
3	Dirty	Allowed if can be removed	MI		Zone A Zone B
4	Chips/Scratch/ Edge crown	 <p>$X \leq 3\text{mm}, Y \leq 0.5\text{mm}$</p>  <p>$2\text{mm} \leq X \text{ or } 2\text{mm} \leq Y$ Allow</p>  <p>$W \leq 0.1\text{mm}, L \leq 5\text{mm}, n \leq 2$ Edge crown: $X \leq 0.3\text{mm}, Y \leq 3\text{mm}$</p>	MI	Visual / Microscope	Zone A Zone B

DATE MAR.02.2018

Version

1.0

TECHNICAL SPECIFICATION

LCM

Page 24 of 25

5	Substrate color difference	Allowed			
6	FPC broken/ Goldfingers oxidation/ scratch	 Not Allow	MA	Visual / Microscope	Zone B
7	PCB damaged/ Poor welding/ Curl	PCB (Circuit area) damaged Not Allow PCB Poor welding Not Allow PCB Curl ≤ 1%	MI	Visual / Ruler	Zone B
8	Edge Adhesives height/FPL/ Edge adhesives bubble	Edge Adhesives height ≤ Display surface Edge adhesives seep in ≤ 1/2 Margin width FPL tolerance ± 0.3mm Edge adhesives bubble: bubble Width ≤ 1/2 Margin width; Length ≤ 0.5mm. n ≤ 3			
9	Protect film	Surface scratch but not effect protect function, Allowed		Visual Inspection	

16.Packing
TBD

DATE MAR.02.2018	Version	1.0	TECHNICAL SPECIFICATION
LCM			Page 25 of 25