

YP6151 同步升压 DC—DC 变换器

特点:

- 高效率, 高压 96%
- 低压启动: 0.9V
- 输入电压范围: 0.9V 至 5V
- 输入电压范围: 2.5V 至 5V (固定/可调节)
- 1.5MHz 恒定频率操作
- 低接同电阻 $R_{DS(on)}$ 内部开关: 0.35 Ω
- 短路保护
- 高开关电流: 1A
- 无需肖特基二极管 ($V_{our} < 4.3V$)
- 超低停机电流 $I_Q < 1\mu A$
- 小外型封装 SOT-23-6 封装 (无铅封装)

应用:

- MP3/MP4
- 点携式媒体播放机
- DSL 调制解调器
- PC 卡
- 蜂窝电话
- 掌上电脑/PDA
- 数码相机/无线电话

描述:

YP6151 是一款输出、恒定频率、同步升压型 DC/DC 变换器。这款以中等功率以中等功率为对象的器件可在 0.9V 至 5V 的输入电压范围内工作, 并具有一个 1.5MHz 恒定开关频率, 应允许采用纤巧型、低成本电容器以及高度仅 2mm 或更低的电感器。

输出电压可在 2.5V 至 5V 的范围内进行调节, 内部同步 0.35 Ω 、1A 电源开关可在无需使用外部肖特基二极管的情况下提供高效率。

在输入电压为 1V, 输入电压为 3.3V 时, YP6151 可提供最高至 200mA 的电流。

YP6151 变换器采用 SOT-23-6 引脚封装。

引脚封装说明:

Pin No.	Pin Name	Function
1	SW	Switch Output
2	VSS	Ground
3	FB	Feedback
4	EN	On/Off(High Enable)
5	VOUT	Output
6	VIN	Input

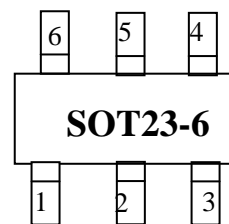

应用线路参考图:

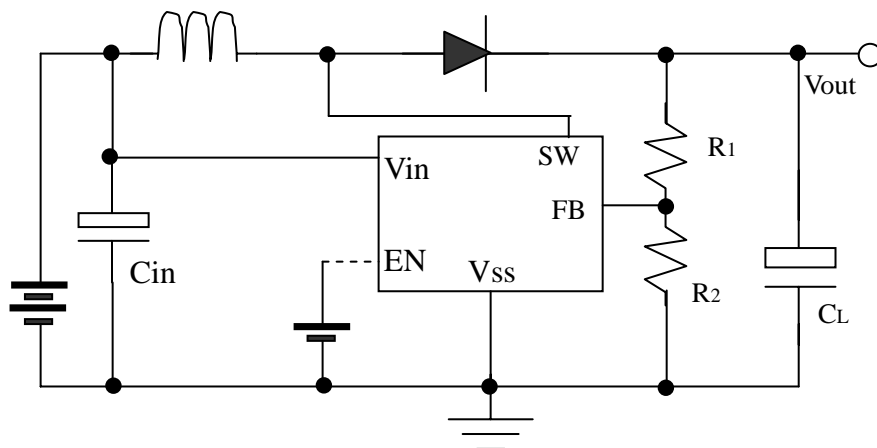

- L: 22 μ H (Sumida)
- D: 1N5819/1N5817
- CL: 16V 20 μ F(Tantalum)
- Cin: 16V 10 μ F
- R1: 1M Ω
- R2: 604KHz

YP6151 同步升压 DC—DC 变换器

电气特性:

Operating conditions: Ta=25 Vin=1.2V Vout=3.3V Unless otherwise specified

Parameter	Condition	Min	Typ	Max	Units
Output Voltage Range(Adj)		2.5		5	V
Minimum Start –UpVoltage	Iload=1mA		0.9	1.1	V
Minium Operating Voltage	EN=VIN		0.5	0.65	V
Switching Frequency		1.1	1.4	1.7	MHz
Max Duty Cycle	VFB=1.15V	80	87		%
Current Limit Delay to Output			40		ns
Feedback Voltage		1.165	1.203	1.241	V
Feedback Input Current	VFB=1.22V		1		nA
NMOS Switch Leakage	VSW=5V		0.1	5	μA
PMOS Switch Leakage	VSW=0V		0.1	5	μA
NMOS Switch On Resistance	VOUT=3.3V		0.35		Ω
PMOS Switch On Resistance	VOUT=3.3V		0.45		Ω
NMOS Current Limit		700	950		mA
Quiescent Current (Active)	Measured On VOUT, Nonswitching		300	500	μA
Shutdown Current	VEN=0V,including Switch Leakage		0.1	1	μA
En Lnpud High		1			V
En Lnpud Low				0.35	V
En Lnpud Current	VEN=5.5V		0.01	1	μA

应用资料:

SW (Pin 1):Switch Pin. Connect inductor between SW and Vin. Keep these PCB trace lengths as short and wide as possible to reduce EMI and voltage overshoot.

VSS (Pin 2):Signal and Power Ground. Provide a short direct PCB path between GND and the(-) side of the output capacitor(s).

FB(Pin 3):feedback Input to the gm Error Amplifier. Connect resistor divider tap to this pin. The output voltage can be adjusted from 2.5V to 5V by: $V_{out}=1.212V [1+(R1/R2)]$

EN(Pin 4): Logic Controlled Shutdown Input. EN=High: Normal free running operation, 1.5MHz typical operating frequency. EN=Low:Shutdown,quiescent current<1uA. Output capacitor can be completely discharged through the load or feedback resistors.

Vout(Pin 5): Output Voltage Sense Input and Drain of the Internal Synchronous Rectifier MOSFET. Bias is derived from Vout. PCB trace length from Vout to the output filter capacitor(s) should be as short and wide as possible.

Vin(Pin 6): Battery Input Voltage. The device gets its start-up bias from Vin. Once Vout exceeds Vin, bias comes from Vout. Thus , once started, operation is completely independent from Vin. Operation is only limited by the output power level and the battery's internal series resistance.

PCB Llayout guidelines.

The high speed operation of the YP6151 demands careful attention to board layout. You will not get advertised performance with careless layout.

YP6151 同步升压 DC—DC 变换器

Inductor selection:

The YP6151 can utilize small surface mount and chip inductors due to its fast 1.5MHz switching frequency. Typically, a 2.2uH inductor is recommended for most applications. Larger values of inductance will allow greater output current capability by reducing the inductor ripple current. Increasing the inductance above 10uH will increase size while providing little improvement in output current capability.

$$I_{out(Max)} = \eta * \{I_p - V_{in} * D / (f * L * 2)\} * (1 - D)$$

where:

η = estimated efficiency

I_p = peak current limit value (0.6A)

V_{in} = input (battery) voltage

D = steady-state duty ratio = $(V_{out} - V_{in}) / V_{out}$

f = switching frequency (1.5MHz typical)

L = inductance value

The inductor current ripple is typically set for 20% to 40% of the maximum inductor current (I_p). High frequency ferrite core inductor materials reduce frequency dependent power losses compared to cheaper powdered iron types, improving efficiency. The inductor should have low ESR (series resistance of the windings) to reduce the $I^2 R$ power losses, and must be able to handle the peak inductor current without saturating. Molded chokes and some chip inductors usually do not have enough core to support the peak inductor currents of 850mA seen on the YP6151. To minimize radiated noise use a toroid, pot core or shielded bobbin inductor. See Table 1 for some suggested components and suppliers.

Table 1. Recommended Inductors.

PART	L (μ H)	MAX DCR m Ω	MAX DC CURRENT (A)	SIZE W x L x H (mm ³)	VENDOR
CDRH3D16	2.2	75	1.20	3.8x3.8x1.8	Sumida
CDH3B16	2.2	70	1.20	4.0x4.0x1.8	Ceaiya

Output and Input Capacitor Selection:

Low ESR (equivalent series resistance) capacitors should be used to minimize the output voltage ripple. Multilayer ceramic capacitors are an excellent choice as they have extremely low ESR and are available in small footprints. A 4.7uF to 20uF output capacitor is sufficient for most applications. Large values up to 22uF may be used to obtain extremely low output voltage ripple and improve transient response. An additional phase lead capacitor may be required with output capacitors larger than 10uF to maintain acceptable phase margin. X5R and X7R dielectric are preferred for their ability to maintain capacitance over wide voltage and temperature ranges.

Low ESR input capacitors reduce input switching noise and reduce the peak current drawn from the battery. It follows that ceramic capacitors are also a good choice for input decoupling and should be located as close as possible to the device. A 10 μ F input capacitor is sufficient for virtually any application. Larger values may be used without limitations. Table 2 shows a list of several ceramic capacitor manufacturers. Consult the manufacturers directly for detailed information on their entire selection of ceramic capacitors.

Table 2. Capacitor Vendor Information

SUPPLIER	WEBSITE
AVX	www.AVXCORP.COM
Murata	www.murata.com
Taiyo Yuden	www.t-yuden.com