

Differential Oscillator



YSO251PJ TCXO - Low Jitter



Applications

- Networking
- Satellite Navigation
- Communications

Features

- RMS Jitter (12KHz ~ 20MHz) : 250 fsec typ. (at 156.250MHz, 3.3V)
- Multiple Output: PECL、LVDS、HCSL、CML
- Package Size: 3.2*2.5mm, 5.0*3.2mm

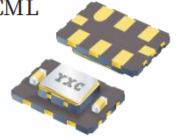

Specifications (规格参数)

Output Type	PECL	LVDS	HCSL	CML
Frequency Range 额定频率范围	15MHz ~ 2100MHz	15MHz ~ 2100MHz	15MHz ~ 700MHz	15MHz ~ 1500MHz
Supply Voltage VDD 电源电压	2.5V, 3.3V	1.8, 2.5V, 3.3V	1.8, 2.5V, 3.3V	1.8, 2.5V, 3.3V
Operating Temperature Range 工作温度	-40 ~ +85°C, or specify			
Storage Temperature Range 储存温度	-55 ~ +150°C			
Output Load 输出负载	50Ω into Vcc - 2V or Thevenin equivalent	100 Ω between output and complimentary output	50 Ω to GND	50 Ω to VDD
Rise Time / Fall Time (Tr / Tf : 10% ↔ 90% waveform) 上升沿/下降沿	0.4 nsec (max.)			
Duty Cycle 占空比	45~55%			
Start-up Time 启动时间	5.0msec (typ.)			
RMS Jitter [12 kHz ~ 20 MHz] 相位抖动	15 MHz ~ 50 MHz : 500 fsec (typ.) ; 51MHz ~ 1,200 MHz : 250 fsec (typ.)			
Current Consumption (max.) (VDD = + 3.3V) 消耗电流	99 mA (typ.)	74 mA (typ.)	79 mA (typ.)	69 mA (typ.)
Initial Calibration Tolerance 初始校准公差	±2.0ppm (max.) at +25°C ±2°C (at the shipment)			
Frequency Stability 频率稳定度	Temperature (ref to +25°C)	± 2.5 ppm over -40 °C to +85°C (typical)		
		± 1.5 ppm over -40°C to +85°C (available)		
	Aging at Ta = +25°C	± 1.0ppm max, pear year at 25°C		
	Voltage Change	± 0.2 ppm (max.) , for a ± 5% input voltage change.		
	Load Change	± 0.2 ppm (max.) , for a ± 10% load condition change.		
	Reflow	± 1.0 ppm (max.) , 1 reflow and measured 24 hours afterwards.		
Output Enable / Disable Function	70% of VDD (min.) to enable output.			
	30% of VDD (max.) to disable output.			

Differential Oscillator



YSO251PJ TCXO - Low Jitter



Pin Dimension (脚位尺寸)

Pin	#1	#2	#3	#4
FUNCTION	Ground	Output Enable	Ground	Output
Pin	#5	#6	#7	#8
FUNCTION	Complementary	Supply Voltage	No Connection	No Connection

Pin Assignments

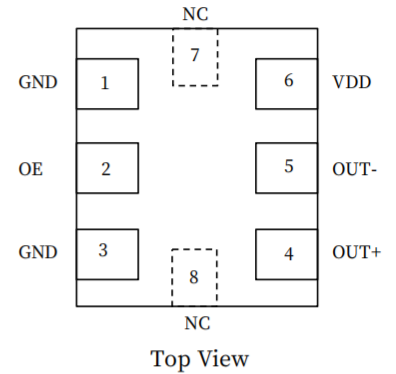

Dimensions and Recommended Land Pattern (外观尺寸及推荐焊盘)

Dimensions (Unit: mm)	Recommended Land Pattern (Unit: mm)
<p>3.2*2.5mm</p>	
<p>5.0*3.2mm</p>	

Differential Oscillator



YSO251PJ TCXO - Low Jitter



Test Circuit (测试电路)

