

**DESCRIPTION**

The YT5166 is a semiconductor integrated circuit for use in servo motor in radio control applications. The built-in voltage regulating circuit, and the differential comparator used in the comparator circuit provide the YT5166 with extremely stable power supply voltage fluctuation characteristics and temperature change characteristics.

FUNCTION

When a peripheral PNP transistor is connected to YT5166, a direct current pulse-duration modulation circuit is completed. When the control input PIN2 (IN) input an adjustable pulse of 20ms cycle and 1.0-2.0ms pulse-duration, the bridge PWM circuit will input accordingly a forward-backward reversible driving voltage. Taking 1.5ms input pulse-duration as balance, the transistor of bridge circuit output a symmetrical voltage of approximately 2.6v and the average voltage on load will be zero. When output pulse duration is increased (decreased), one side (or the other side) of the bridge circuit is turned on. The period of turning on is the direct ratio with the difference between input pulse-duration and balance point (1.5ms). When pulse-duration is 2.0ms, load voltage is close to +Vcc. When pulse-duration is 1.0ms, load voltage is close to -Vcc. When input pulse-duration is balance (1.5ms) and output is not balance, adjust voltage of PIN11 to balance. With this characteristic, the bridge circuit could drive a mechanical position sensor (adjustable resistor) and form a position loop to build up a position controller.

FEATURES

- Small circuit current: 5 mA (When output is off)
- Simple setting of dead band
- Supply voltage range: 3.5-6.5V
- Operating temperature: -20 - +75
- Includes protection circuit for continuous high level input
- Logic inputs CMOS/TTL compatible

ORDERING INFORMATION

Model	Package	Temperature Range()
YT5166	DIP14	-20 - +75
	DIE	-20 - +75

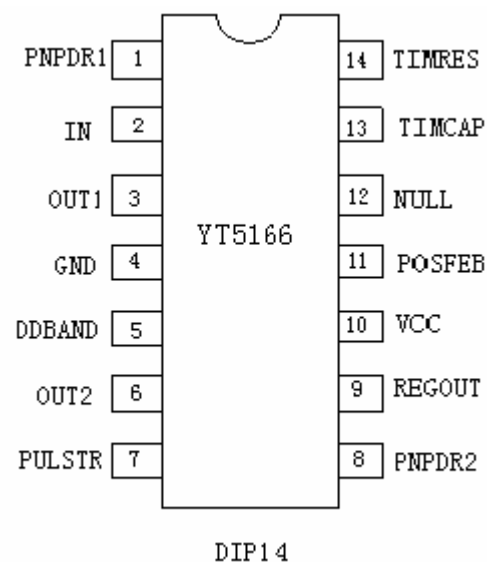
PIN CONFIGURATION

PIN DESCRIPTION

Pin Number	PIN Symbol	I/O	Pin Description and (or) Function
PIN1	PNPDR1	O	Connect to the base of the external PNP transistor.
PIN2	IN	I	Operate with a positive pulse of peak value 3V or greater. Normative cycle T=20ms, pulse-duration 1.0-2.0ms adjustable.
PIN3	OUT1	O	Connect a feedback resistor of stated 560kΩ between PIN3 and PIN13
PIN4	GND		Ground ;
PIN5	DDBAND	I	Connect a resistor between PIN5 and PIN7. The dead band will change according to the value of this resistor. The range of the resistor is 2-20kΩ ;
PIN6	OUT2	O	Connect to the collector of the external PNP transistor.
PIN7	PULSTR	I	Connect the capacitor and resistor to stretch the pulse; Connect a resistor of 220k* to PIN9.
PIN8	PNPDR2	O	Connect to the base of the external PNP transistor.
PIN9	REGOUT	O	Regulate the output of internal supply voltage; Connect a capacitor of approximately 2.2μF for increasing the circuit stability.
PIN10	VCC		The supply voltage exhibits uniform characteristics from 3.5V to 6.5V.
PIN11	POSFEB	I	Connect the middle of the potentiometer to adjust internal comparator input voltage. Compare this voltage with the voltage of the triangular wave to adjust balance. Connect a capacitor for the noise prevention.
PIN12	NULL		Null
PIN13	TIMECAP	O	Connect a capacitor that will generate a triangular wave by constant current. A typical value is 0.1μF. Must use CBB or NPO capacitor with high temperature tolerance; Connect a resistor from the OUT1.
PIN14	TIMRES	O	Connect a resistor that will determine that value of the current of PIN13. A resistor of 18k will yield a current of 1.0mA. A capacitor of approximately 0.1μF should be connected in parallel with the resistor to increase stability.

*When the dead band resistor connected between PIN5 and PIN7 is high value , the external resistor of PIN7 should be increased accordingly; So that the output pulse of PIN1 and PIN8 have enough duration.

Example: When RDB = 10K , RS = 330K ; When RDB=20K , RS=430K.

ABSOLUTE MAXIMUM RATING (TA=25)

Symbol	Description	Test Conditions	Value	Unit
Vcc	Circuit voltage		7.0	V
Io SINK	Output sink current		500	mA
Io SOURCE	Output source current		200	mA
pd _F	Power dissipation		550	mW
K?	Thermal derating range	Ta = 25	5.5	mW/
Topr	Operating temperature		-20- +75	
Tstg	Storage temperature range	V _I =5V	-40-+125	

ELECTRICAL CHARACTERISTICS ($T_A=25$, $V_{CC}=4.8V$)

Pin No.	Symbol	Parameter	Test conditions	Range			Unit
				Min.	Typ.	Max.	
PIN10	Vcc	Supply voltage		3.5	5	6.5	V
PIN10	Icc	Operating voltage	Non-operating		3.5	5	mA
			Operating		20		
PIN9	Vreg	Reference voltage		2.3	2.55	2.8	V
PIN9	Ireg	Reference voltage output current				3.0	mA
PIN2	Tdb	Min. dead band width	RDB=2K CS=0.1uF			20	us
PIN2	Ii	Input current			1		mA

BLOCK DIAGRAM

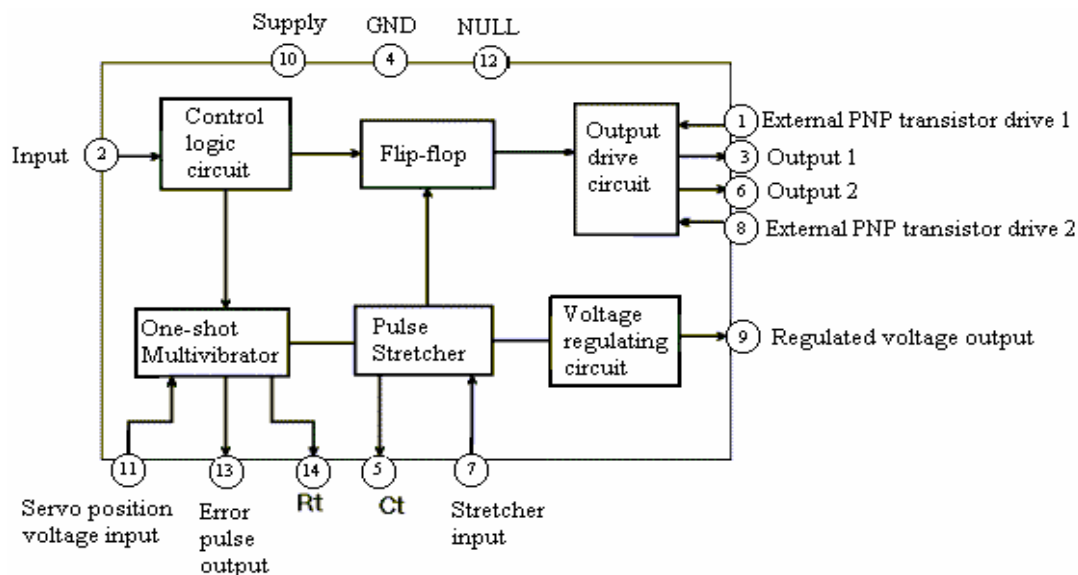

TYPICAL APPLICATION CIRCUIT

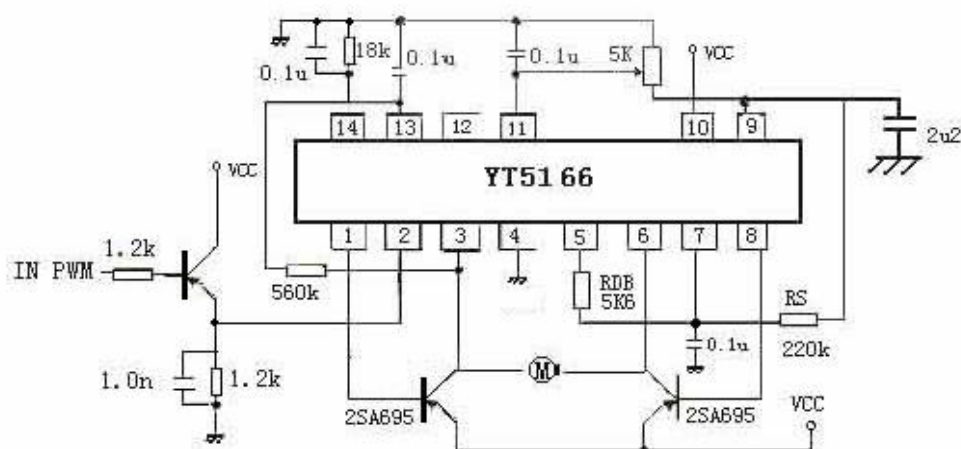

PACKAGE OUTLINE DIMENSIONS

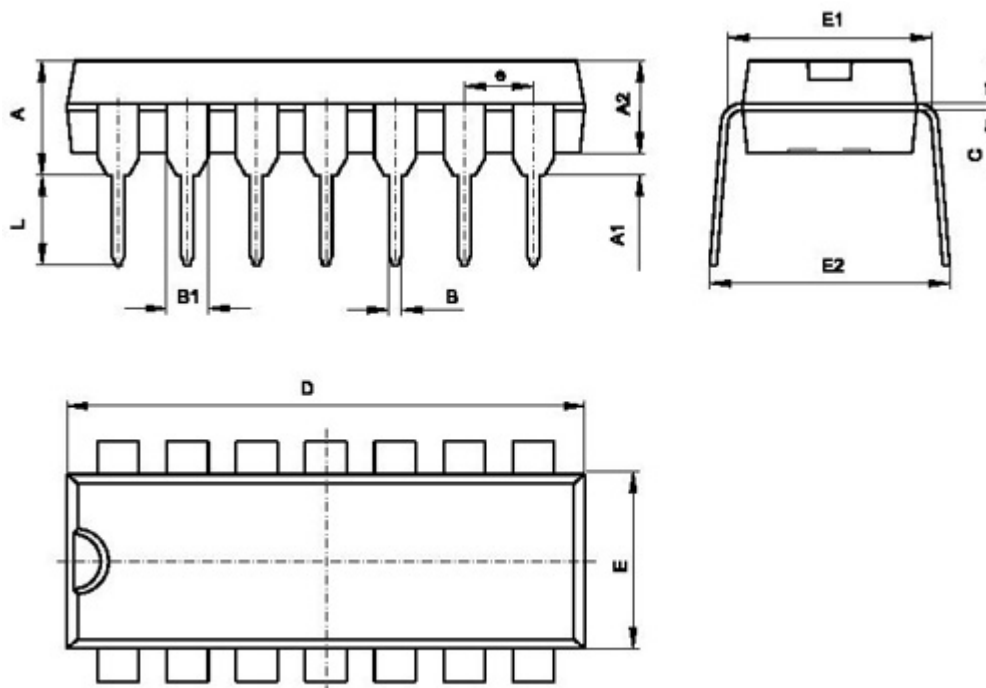

Symbol	Dimensions in Millimeters		Dimensions in Inches	
	MIN	MAX	MIN	MAX
A	3.710	4.310	0.146	0.170
A1	0.510		0.020	
A2	3.200	3.600	0.126	0.142
B	0.360	0.560	0.014	0.022
B1	1.524(TYP)		0.060(TYP)	
C	0.204	0.360	0.008	0.014
D	18.800	19.200	0.740	0.756
E	6.200	6.600	0.244	0.260
E1	7.620(TYP)		0.300(TYP)	
e	2.540(TYP)		0.100(TYP)	
L	3.000	3.600	0.118	0.142
E2	8.200	9.400	0.323	0.370

*Chip size: 3.31*2.20mm.

WAVE DIAGRAM

1. PIN2 is a square wave with adjustable cycle duty.
2. The supply voltage is 4.8V.
3. The voltage of PIN9 is 2.3-2.8v, typically 2.55v.
4. Connect a resistor between PIN3 & PIN6 to make the output current 100mA. (Or connect a motor. The turning direction and speed of the motor will be changed according to the cycle duty of the input voltage.)

