

256Mb Synchronous DRAM Specification

Z2V56S20BTP

Z2V56S30BTP

Z2V56S40BTP



Deutron Electronics Corp.

8F, 68, SEC. 3, NANKING E. RD., TAIPEI 104,

TAIWAN, R. O. C.

TEL : 886-2-2517-7768

FAX : 886-2-2517-4575

<http://www.deutron.com.tw>



256Mb Synchronous DRAM

ORDERING INFORMATION

Frequency	Speed(ns)	Order Part Number					Package
		Type	Standard	Low Power	Pb-Free	Low Power and Pb-Free	
166MHz	6	Z2V56S20/30/40 BTP	-6	-6L	-G6	-G6L	400mil TSOP-2
143MHz	7	Z2V56S20/30/40 BTP	-7	-7L	-G7	-G7L	400mil TSOP-2
133MHz	7.5	Z2V56S20/30/40 BTP	-75	-75L	-G75	-G75L	400mil TSOP-2
125MHz	8	Z2V56S20/30/40 BTP	-8	-8L	-G8	-G8L	400mil TSOP-2

Type Designation Code

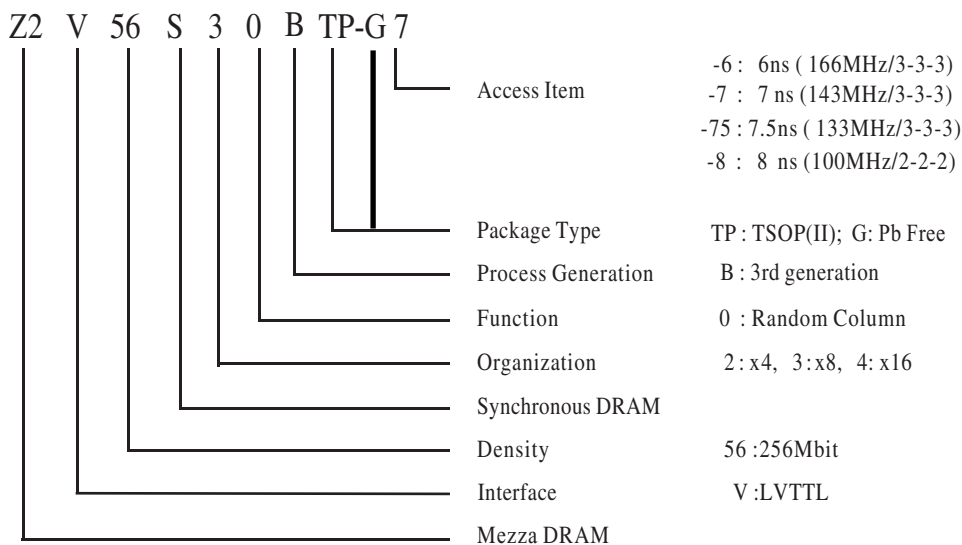



256Mb Synchronous DRAM

Z2V56S20BTP (4-BANK x 16,777,216-WORD x 4-BIT)

Z2V56S30BTP (4-BANK x 8,388,6084-WORD x 8-BIT)

Z2V56S40BTP (4-BANK x 4,194,304-WORD x 16-BIT)

PRELIMINARY

Some of contents are described for general products and are subject to change without notice.

DESCRIPTION

Z2V56S20BTP is organized as 4-bank x 16,777,216-word x 4-bit Synchronous DRAM with LVTTL interface and Z2V56S30BTP is organized as 4-bank x 8,388,608-word x 8-bit and Z2V56S40BTP is organized as 4-bank x 4,194,304-word x 16-bit. All inputs and outputs are referenced to the rising edge of CLK.

Z2V56S20BTP, Z2V56S30BTP and Z2V56S40BTP achieve very high speed clock rates up to 166MHz, and are suitable for main memories or graphic memories in computer systems.

FEATURES

ITEM			Z2V56S20/30/40BTP				
			-6	-7	-75	-8	Unit
tCLK	Clock Cycle Time (Min.)	CL=2	-	-	10	10	ns
		CL=3	6	7	7.5	8	ns
tRAS	Active to Precharge Command Period (Min.)		42	45	45	48	ns
tRCD	Row to Column Delay (Min.)		15	20	20	20	ns
tAC	Access Time from CLK (Max.)	CL=2	-	-	6	6	ns
		CL=3	5	5.4	5.4	6	ns
tRC	Ref /Active Command Period (Min.)		60	63	67.5	70	ns
Icc1	Operation Current (Single Bank) (Max.)	V56S20	100	100	100	95	mA
		V56S30	110	110	110	100	mA
		V56S40	130	130	130	120	mA
Icc6	Self Refresh Current (Max.)	-6,-7,-75,-8	3	3	3	3	mA

- Single 3.3V \pm 0.3V power supply

- Max. Clock frequency:

-6:166MHz<3-3-3>/-7:143MHz<3-3-3>/-75:133MHz<3-3-3>/-8:100MHz<2-2-2>

- Fully synchronous operation referenced to clock rising edge

- 4-bank operation controlled by BA0,BA1(Bank Address)

- /CAS latency- 2/3 (programmable)

- Burst length- 1/2/4/8/FP (programmable)

- Burst type- Sequential and interleave burst (programmable)

- Byte Control- DQML and DQMU (P2V56S40BTP)

- Random column access

- Auto precharge / All bank precharge controlled by A10

- Auto and self refresh

- 8192 refresh cycles /64ms(4 banks concurrent refresh)

- LVTTL Interface

- Row address A0-12 /Column address A0-9, 11(x4) / A0-9(x8) / A0-8(x16)

- Package

400-mil, 54-pin Thin Small Outline (TSOP II) with 0.8mm lead pitch



Z2V56S20BTP (4-BANK x 16,777,216-WORD x 4-BIT)
 Z2V56S30BTP (4-BANK x 8,388,608-WORD x 8-BIT)
 Z2V56S40BTP (4-BANK x 4,194,304-WORD x 16-BIT)

PIN CONFIGURATION (TOP VIEW)

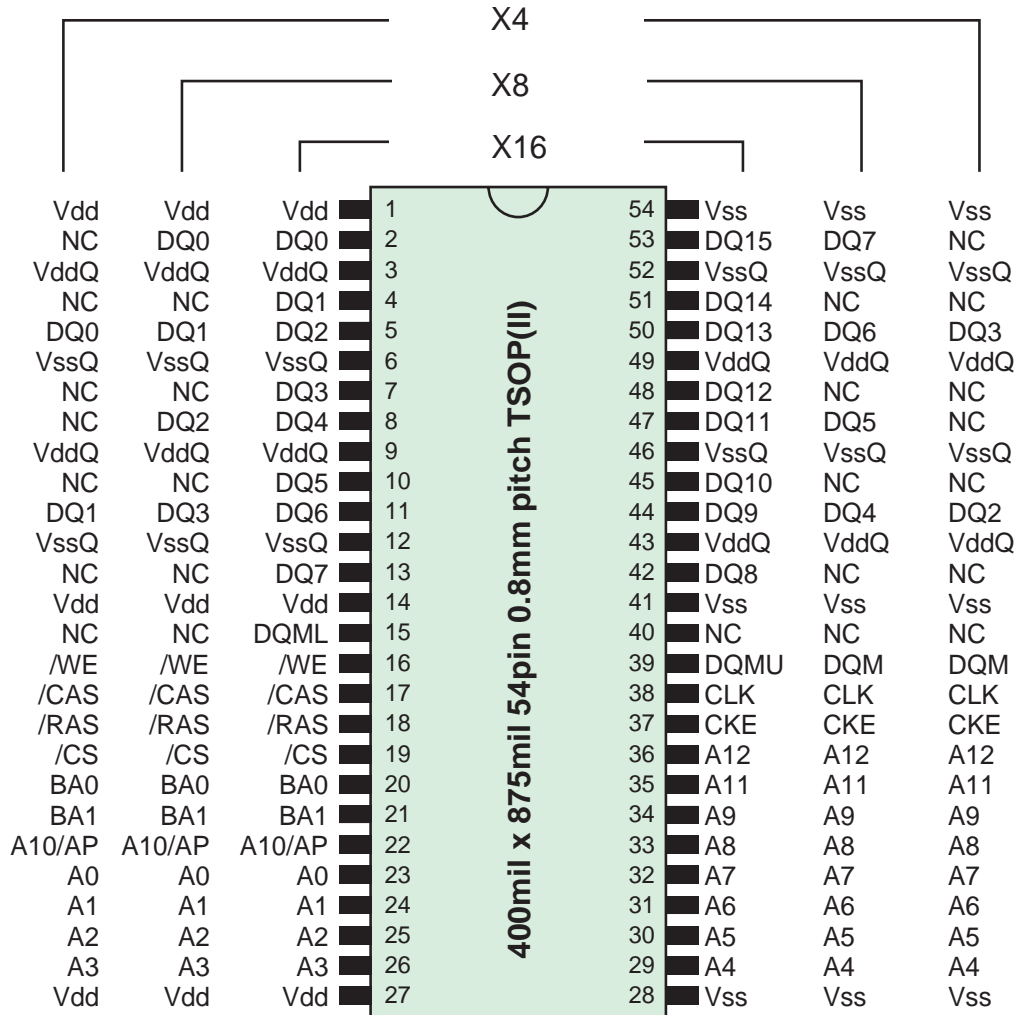

CLK : Master Clock
CKE : Clock Enable
/CS : Chip Select
/RAS : Row Address Strobe
/CAS : Column Address Strobe
/WE : Write Enable
DQ0-15 : Data I/O

DQM, DQMU/L : Output Disable / Write Mask
A0-12 : Address Input
BA0,1 : Bank Address Input
Vdd : Power Supply
VddQ : Power Supply for Output
Vss : Ground
VssQ : Ground for Output



Z2V56S20BTP (4-BANK x 16,777,216-WORD x 4-BIT)
 Z2V56S30BTP (4-BANK x 8,388,608-WORD x 8-BIT)
 Z2V56S40BTP (4-BANK x 4,194,304-WORD x 16-BIT)

BLOCK DIAGRAM

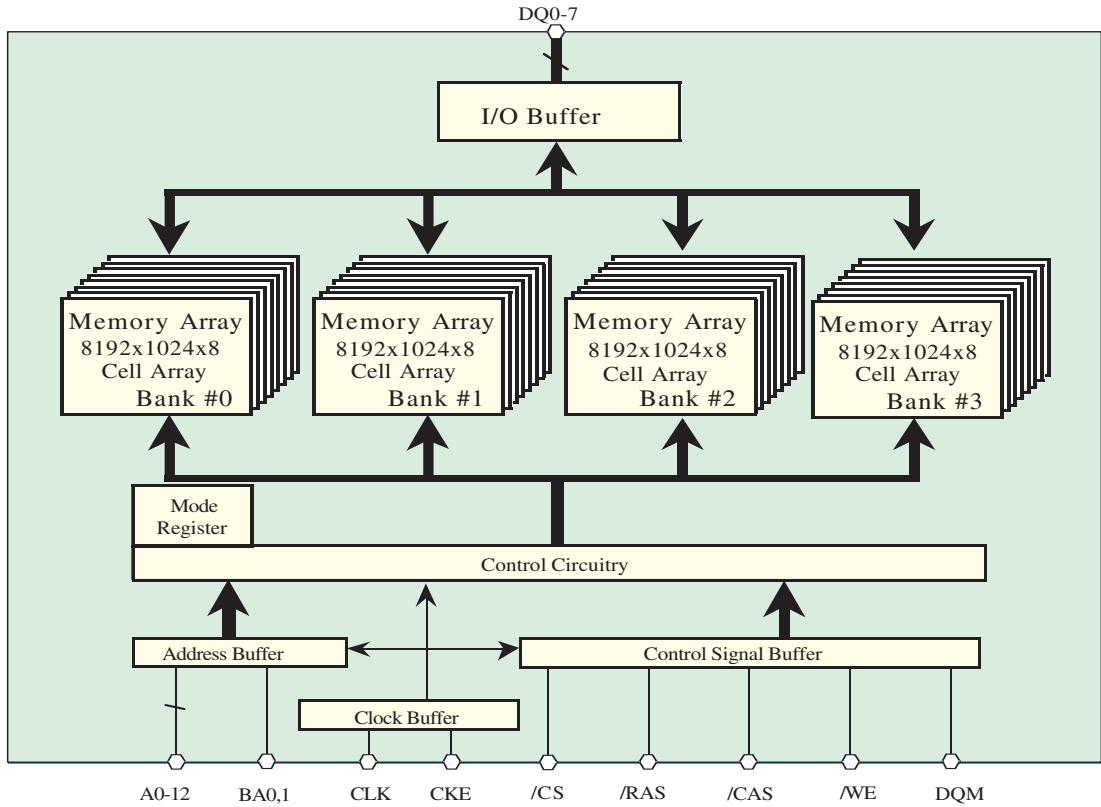

Note: This figure shows the Z2V56S30BTP
 The Z2V56S20BTP configuration is 8192x2048x4 of cell array and DQ0-3
 The Z2V56S40BTP configuration is 8192x512x16 of cell array and DQ0-15

Type Designation Code

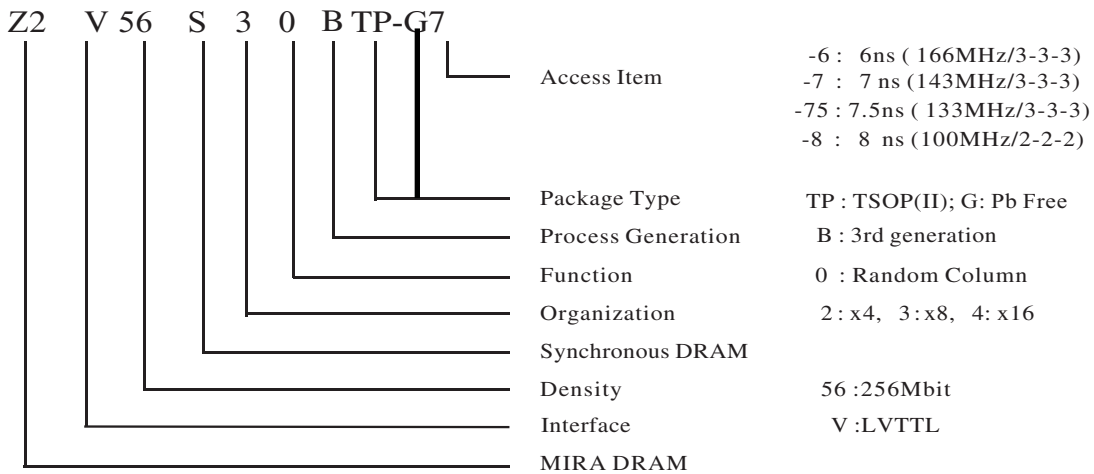

PIN FUNCTION

CLK	Input	Master Clock: All other inputs are referenced to the rising edge of CLK
CKE	Input	Clock Enable: CKE controls internal clock. When CKE is low, internal clock for the following cycle is ceased. CKE is also used to select auto / self-refresh. After self-refresh mode is started, CKE becomes asynchronous input. Self-refresh is maintained as long as CKE is low.
/CS	Input	Chip Select: When /CS is high, any command means No Operation.
/RAS, /CAS, /WE	Input	Combination of /RAS, /CAS, /WE defines basic commands.
A0-12	Input	A0-12 specify the Row / Column Address in conjunction with BA0,1. The Row Address is specified by A0-12. The Column Address is specified by A0-9,11(x4)/A0-9(x8)/A0-8(x16). A10 is also used to indicate precharge option. When A10 is high at a read / write command, an auto precharge is performed. When A10 is high at a precharge command, all banks are precharged.
BA0,1	Input	Bank Address: BA0,1 specifies one of four banks to which a command is applied. BA0,1 must be set with ACT, PRE, READ, WRITE commands.
DQ0-3(x4), DQ0-7(x8), DQ0-15(x16)	Input / Output	Data In and Data out are referenced to the rising edge of CLK.
DQM(x4,x8), DQMU/L(x16)	Input	Din Mask / Output Disable: When DQM(U/L) is high in burst write, Din for the current cycle is masked. When DQM(U/L) is high in burst read, Dout is disabled at the next but one cycle.
Vdd, Vss	Power Supply	Power Supply for the memory array and peripheral circuitry.
VddQ, VssQ	Power Supply	VddQ and VssQ are supplied to the Output Buffers only.



BASIC FUNCTIONS

The Z2V56S20 , 30 and 40 BTP provides basic functions, bank (row) activate, burst read / write, bank (row) precharge, and auto / self refresh.

Each command is defined by control signals of /RAS,

/CAS and /WE at CLK rising edge. In addition to 3 signals, /CS ,CKE and A10 are used as chip select, refresh option, and precharge option, respectively .

To know the detailed definition of commands, please see the command truth table.

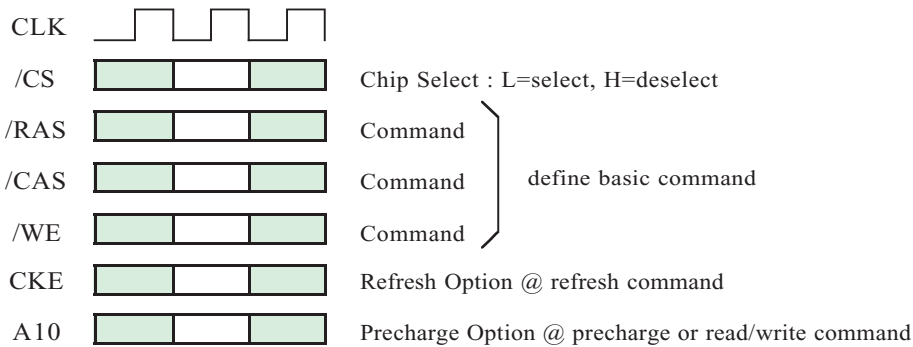

Activate (ACT) [/RAS =L, /CAS =/WE =H]

ACT command activates a row in an idle bank indicated by BA.

Read (READ) [/RAS =H, /CAS =L, /WE =H]

READ command starts burst read from the active bank indicated by BA. First output data appears after /CAS latency. When A10 =H at this command, the bank is deactivated after the burst read (auto-precharge, **READA**).

Write (WRITE) [/RAS =H, /CAS =/WE =L]

WRITE command starts burst write to the active bank indicated by BA. Total data length to be written is set by burst length. When A10 =H at this command, the bank is deactivated after the burst write (auto-precharge, **WRITEA**).

Precharge (PRE) [/RAS =L, /CAS =H, /WE =L]

PRE command deactivates the active bank indicated by BA. This command also terminates burst read / write operation. When A10 =H at this command, all banks are deactivated (precharge all, **PREA**).

Auto-Refresh (REFA) [/RAS =/CAS =L, /WE =CKE =H]

REFA command starts auto-refresh cycle. Refresh address including bank address are generated internally. After this command, the banks are precharged automatically.



Z2V56S20BTP (4-BANK x 16,777,216-WORD x 4-BIT)
 Z2V56S30BTP (4-BANK x 8,388,608-WORD x 8-BIT)
 Z2V56S40BTP (4-BANK x 4,194,304-WORD x 16-BIT)

COMMAND TRUTH TABLE

COMMAND	MNEMONIC	CKE n-1	CKE n	/CS	/RAS	/CAS	/WE	BA0,1	A10 /AP	A0-9, 11-12	note
Deselect	DESEL	H	X	H	X	X	X	X	X	X	
No Operation	NOP	H	X	L	H	H	H	X	X	X	
Row Address Entry & Bank Activate	ACT	H	X	L	L	H	H	V	V	V	
Single Bank Precharge	PRE	H	X	L	L	H	L	V	L	X	
Precharge All Banks	PREA	H	X	L	L	H	L	X	H	X	
Column Address Entry & Write	WRITE	H	X	L	H	L	L	V	L	V	
Column Address Entry & Write with Auto-Precharge	WRITEA	H	X	L	H	L	L	V	H	V	
Column Address Entry & Read	READ	H	X	L	H	L	H	V	L	V	
Column Address Entry & Read with Auto-Precharge	READA	H	X	L	H	L	H	V	H	V	
Auto-Refresh	REFA	H	H	L	L	L	H	X	X	X	
Self-Refresh Entry	REFS	H	L	L	L	L	H	X	X	X	
Self-Refresh Exit	REFSX	L	H	H	X	X	X	X	X	X	
		L	H	L	H	H	H	X	X	X	
Burst Terminate	TBST	H	X	L	H	H	L	X	X	X	
Mode Register Set	MRS	H	X	L	L	L	L	L	L	V	1

H=High Level, L=Low Level, V=Valid, X=Don't Care, n=CLK cycle number

NOTE:

- A7-9,11-12=L, A0-A6 =Mode Address



FUNCTION TRUTH TABLE

Current State	/CS	/RAS	/CAS	/WE	Address	Command	Action
IDLE	H	X	X	X	X	DESEL	NOP
	L	H	H	H	X	NOP	NOP
	L	H	H	L	X	TBST	ILLEGAL*2
	L	H	L	X	BA, CA, A10	READ / WRITE	ILLEGAL*2
	L	L	H	H	BA, RA	ACT	Bank Active, Latch RA
	L	L	H	L	BA, A10	PRE / PREA	NOP*4
	L	L	L	H	X	REFA	Auto-Refresh*5
	L	L	L	L	Op-Code, Mode-Add	MRS	Mode Register Set*5
ROW ACTIVE	H	X	X	X	X	DESEL	NOP
	L	H	H	H	X	NOP	NOP
	L	H	H	L	X	TBST	NOP
	L	H	L	H	BA, CA, A10	READ / READA	Begin Read, Latch CA, Determine Auto-Precharge
	L	H	L	L	BA, CA, A10	WRITE / WRITEA	Begin Write, Latch CA, Determine Auto-Precharge
	L	L	H	H	BA, RA	ACT	Bank Active / ILLEGAL*2
	L	L	H	L	BA, A10	PRE / PREA	Precharge / Precharge All
	L	L	L	H	X	REFA	ILLEGAL
	L	L	L	L	Op-Code, Mode-Add	MRS	ILLEGAL
READ	H	X	X	X	X	DESEL	NOP (Continue Burst to END)
	L	H	H	H	X	NOP	NOP (Continue Burst to END)
	L	H	H	L	X	TBST	Terminate Burst
	L	H	L	H	BA, CA, A10	READ / READA	Terminate Burst, Latch CA, Begin New Read, Determine Auto-Precharge*3
	L	H	L	L	BA, CA, A10	WRITE / WRITEA	Terminate Burst, Latch CA, Begin Write, Determine Auto- Precharge*3
	L	L	H	H	BA, RA	ACT	Bank Active / ILLEGAL*2
	L	L	H	L	BA, A10	PRE / PREA	Terminate Burst, Precharge
	L	L	L	H	X	REFA	ILLEGAL
	L	L	L	L	Op-Code, Mode-Add	MRS	ILLEGAL



Z2V56S20BTP (4-BANK x 16,777,216-WORD x 4-BIT)
 Z2V56S30BTP (4-BANK x 8,388,608-WORD x 8-BIT)
 Z2V56S40BTP (4-BANK x 4,194,304-WORD x 16-BIT)

FUNCTION TRUTH TABLE (continued)

Current State	/CS	/RAS	/CAS	/WE	Address	Command	Action
WRITE	H	X	X	X	X	DESEL	NOP (Continue Burst to END)
	L	H	H	H	X	NOP	NOP (Continue Burst to END)
	L	H	H	L	X	TBST	Terminate Burst
	L	H	L	H	BA, CA, A10	READ / READA	Terminate Burst, Latch CA, Begin Read, Determine Auto-Precharge*3
	L	H	L	L	BA, CA, A10	WRITE / WRITEA	Terminate Burst, Latch CA, Begin Write, Determine Auto-Precharge*3
	L	L	H	H	BA, RA	ACT	Bank Active / ILLEGAL*2
	L	L	H	L	BA, A10	PRE / PREA	Terminate Burst, Precharge
	L	L	L	H	X	REFA	ILLEGAL
	L	L	L	L	Op-Code, Mode-Add	MRS	ILLEGAL
READ with AUTO PRECHARGE	H	X	X	X	X	DESEL	NOP (Continue Burst to END)
	L	H	H	H	X	NOP	NOP (Continue Burst to END)
	L	H	H	L	X	TBST	ILLEGAL
	L	H	L	H	BA, CA, A10	READ / READA	ILLEGAL
	L	H	L	L	BA, CA, A10	WRITE / WRITEA	ILLEGAL
	L	L	H	H	BA, RA	ACT	Bank Active / ILLEGAL*2
	L	L	H	L	BA, A10	PRE / PREA	ILLEGAL*2
	L	L	L	H	X	REFA	ILLEGAL
	L	L	L	L	Op-Code, Mode-Add	MRS	ILLEGAL
WRITE with AUTO PRECHARGE	H	X	X	X	X	DESEL	NOP (Continue Burst to END)
	L	H	H	H	X	NOP	NOP (Continue Burst to END)
	L	H	H	L	X	TBST	ILLEGAL
	L	H	L	H	BA, CA, A10	READ / READA	ILLEGAL
	L	H	L	L	BA, CA, A10	WRITE / WRITEA	ILLEGAL
	L	L	H	H	BA, RA	ACT	Bank Active / ILLEGAL*2
	L	L	H	L	BA, A10	PRE / PREA	ILLEGAL*2
	L	L	L	H	X	REFA	ILLEGAL
	L	L	L	L	Op-Code, Mode-Add	MRS	ILLEGAL



FUNCTION TRUTH TABLE (continued)

Current State	/CS	/RAS	/CAS	/WE	Address	Command	Action
PRE - CHARGING	H	X	X	X	X	DESEL	NOP (Idle after tRP)
	L	H	H	H	X	NOP	NOP (Idle after tRP)
	L	H	H	L	X	TBST	ILLEGAL*2
	L	H	L	X	BA, CA, A10	READ / WRITE	ILLEGAL*2
	L	L	H	H	BA, RA	ACT	ILLEGAL*2
	L	L	H	L	BA, A10	PRE / PREA	NOP*4 (Idle after tRP)
	L	L	L	H	X	REFA	ILLEGAL
	L	L	L	L	Op-Code, Mode-Add	MRS	ILLEGAL
ROW ACTIVATING	H	X	X	X	X	DESEL	NOP (Row Active after tRCD)
	L	H	H	H	X	NOP	NOP (Row Active after tRCD)
	L	H	H	L	X	TBST	ILLEGAL*2
	L	H	L	X	BA, CA, A10	READ / WRITE	ILLEGAL*2
	L	L	H	H	BA, RA	ACT	ILLEGAL*2
	L	L	H	L	BA, A10	PRE / PREA	ILLEGAL*2
	L	L	L	H	X	REFA	ILLEGAL
	L	L	L	L	Op-Code, Mode-Add	MRS	ILLEGAL
WRITE RE-COVERING	H	X	X	X	X	DESEL	NOP
	L	H	H	H	X	NOP	NOP
	L	H	H	L	X	TBST	ILLEGAL*2
	L	H	L	X	BA, CA, A10	READ / WRITE	ILLEGAL*2
	L	L	H	H	BA, RA	ACT	ILLEGAL*2
	L	L	H	L	BA, A10	PRE / PREA	ILLEGAL*2
	L	L	L	H	X	REFA	ILLEGAL
	L	L	L	L	Op-Code, Mode-Add	MRS	ILLEGAL



FUNCTION TRUTH TABLE (continued)

Current State	/CS	/RAS	/CAS	/WE	Address	Command	Action
RE-FRESHING	H	X	X	X	X	DESEL	NOP (Idle after tRC)
	L	H	H	H	X	NOP	NOP (Idle after tRC)
	L	H	H	L	X	TBST	ILLEGAL
	L	H	L	X	BA, CA, A10	READ / WRITE	ILLEGAL
	L	L	H	H	BA, RA	ACT	ILLEGAL
	L	L	H	L	BA, A10	PRE / PREA	ILLEGAL
	L	L	L	H	X	REFA	ILLEGAL
MODE REGISTER SETTING	L	L	L	L	Op-Code, Mode-Add	MRS	ILLEGAL
	H	X	X	X	X	DESEL	NOP (Idle after tRSC)
	L	H	H	H	X	NOP	NOP (Idle after tRSC)
	L	H	H	L	X	TBST	ILLEGAL
	L	H	L	X	BA, CA, A10	READ / WRITE	ILLEGAL
	L	L	H	H	BA, RA	ACT	ILLEGAL
	L	L	H	L	BA, A10	PRE / PREA	ILLEGAL
L	L	L	H	X	REFA	ILLEGAL	
L	L	L	L	Op-Code, Mode-Add	MRS	ILLEGAL	

ABBREVIATIONS:

H=High Level, L=Low Level, X=Don't Care

BA=Bank Address, RA=Row Address, CA=Column Address, NOP=No Operation

NOTES:

1. All entries assume that CKE was High during the preceding clock cycle and the current clock cycle.
2. ILLEGAL to bank in specified state; function may be legal in the bank indicated by BA, depending on the state of that bank.
3. Must satisfy bus contention, bus turn around, write recovery requirements.
4. NOP to bank precharging or in idle state. May precharge bank indicated by BA.
5. ILLEGAL if any bank is not idle.

ILLEGAL = Device operation and/or data-integrity are not guaranteed.



FUNCTION TRUTH TABLE (continued)

Current State	CKE _{n-1}	CKE _n	/CS	/RAS	/CAS	/WE	Add	Action
SELF-REFRESH*1	H	X	X	X	X	X	X	INVALID
	L	H	H	X	X	X	X	Exit Self-Refresh (Idle after tRC)
	L	H	L	H	H	H	X	Exit Self-Refresh (Idle after tRC)
	L	H	L	H	H	L	X	ILLEGAL
	L	H	L	H	L	X	X	ILLEGAL
	L	H	L	L	X	X	X	ILLEGAL
	L	L	X	X	X	X	X	NOP (Maintain Self-Refresh)
POWER DOWN	H	X	X	X	X	X	X	INVALID
	L	H	X	X	X	X	X	Exit Power Down to Idle
	L	L	X	X	X	X	X	NOP (Maintain Power Down)
ALL BANKS IDLE*2	H	H	X	X	X	X	X	Refer to Function Truth Table
	H	L	L	L	L	H	X	Enter Self-Refresh
	H	L	H	X	X	X	X	Enter Power Down
	H	L	L	H	H	H	X	Enter Power Down
	H	L	L	H	H	L	X	ILLEGAL
	H	L	L	H	L	X	X	ILLEGAL
	H	L	L	L	X	X	X	ILLEGAL
	L	X	X	X	X	X	X	Refer to Current State =Power Down
ANY STATE other than listed above	H	H	X	X	X	X	X	Refer to Function Truth Table
	H	L	X	X	X	X	X	Begin CLK Suspend at Next Cycle*3
	L	H	X	X	X	X	X	Exit CLK Suspend at Next Cycle*3
	L	L	X	X	X	X	X	Maintain CLK Suspend

ABBREVIATIONS:

H=High Level, L=Low Level, X=Don't Care

NOTES:

1. CKE Low to High transition will re-enable CLK and other inputs **asynchronously**. A minimum setup time must be satisfied before any command other than EXIT.
2. Self-Refresh can be entered only from the All Banks Idle State.
3. Must be legal command.



SIMPLIFIED STATE DIAGRAM

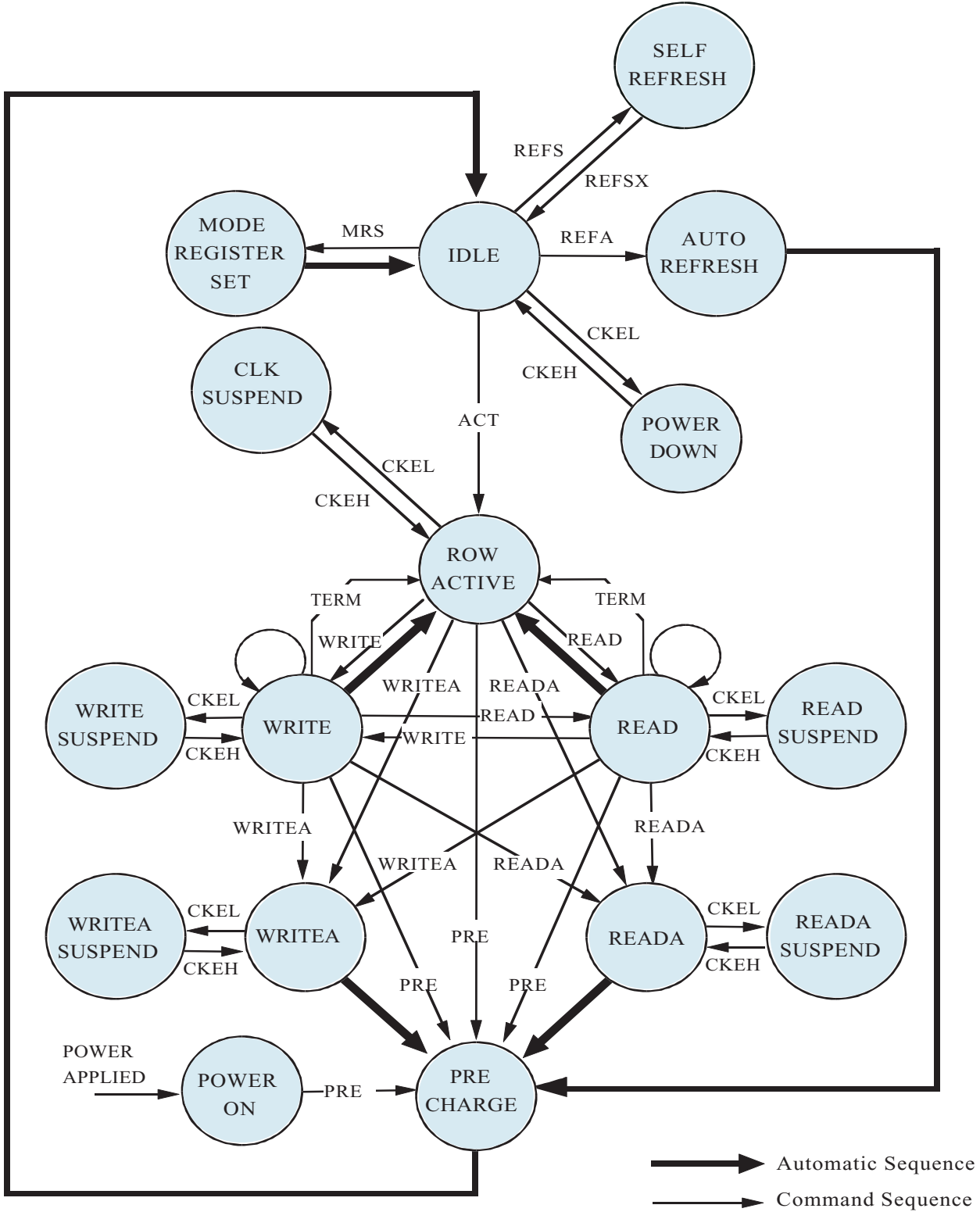



Z2V56S20BTP (4-BANK x 16,777,216-WORD x 4-BIT)
 Z2V56S30BTP (4-BANK x 8,388,608-WORD x 8-BIT)
 Z2V56S40BTP (4-BANK x 4,194,304-WORD x 16-BIT)

POWER ON SEQUENCE

Before starting normal operation, the following power on sequence is necessary to prevent a SDRAM from damaged or malfunctioning.

1. Apply power and start clock. Attempt to maintain CKE high, DQM high and NOP condition at the inputs.
2. Maintain stable power, stable clock, and NOP input conditions for a minimum of 200µs.
3. Issue precharge commands for all banks. (PRE or PREA)
4. After all banks become idle state (after tRP), issue 8 or more auto-refresh commands.
5. Issue a mode register set command to initialize the mode register.

After these sequence, the SDRAM is idle state and ready for normal operation.

MODE REGISTER

Burst Length, Burst Type and /CAS Latency can be programmed by setting the mode register (MRS). The mode register stores these data until the next MRS command, which may be issued when all banks are in idle state. After tRSC from a MRS command, the SDRAM is ready for new command.

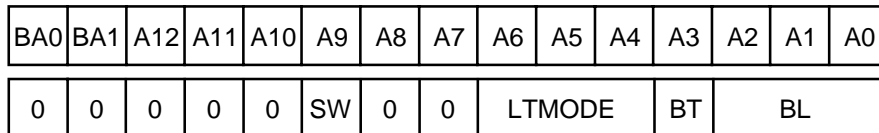
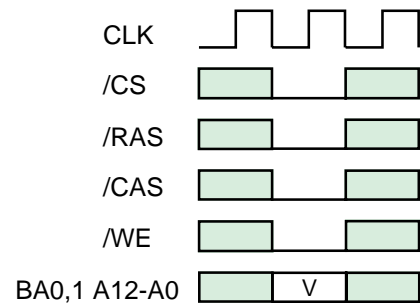

SW	0	Burst Write
	1	Single Write

LATENCY MODE	CL	/CAS LATENCY
	0 0 0	R
	0 0 1	R
	0 1 0	2
	0 1 1	3
	1 0 0	R
	1 0 1	R
	1 1 0	R
1 1 1	R	

BURST LENGTH	BL	BT=0	BT=1
	0 0 0	1	1
	0 0 1	2	2
	0 1 0	4	4
	0 1 1	8	8
	1 0 0	R	R
	1 0 1	R	R
	1 1 0	R	R
1 1 1	Full Page	R	

BURST TYPE	0	SEQUENTIAL
	1	INTERLEAVED

R: Reserved for Future Use



256Mb Synchronous DRAM

Z2V56S20BTP (4-BANK x 16,777,216-WORD x 4-BIT)
 Z2V56S30BTP (4-BANK x 8,388,608-WORD x 8-BIT)
 Z2V56S40BTP (4-BANK x 4,194,304-WORD x 16-BIT)

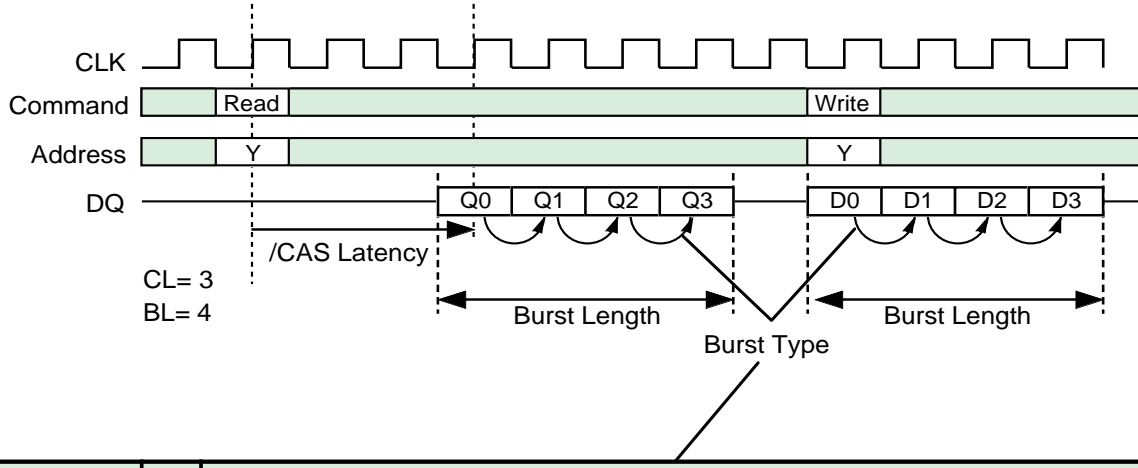

Initial Address			BL	Column Addressing															
A2	A1	A0		Sequential								Interleaved							
0	0	0	8	0	1	2	3	4	5	6	7	0	1	2	3	4	5	6	7
0	0	1		1	2	3	4	5	6	7	0	1	0	3	2	5	4	7	6
0	1	0		2	3	4	5	6	7	0	1	2	3	0	1	6	7	4	5
0	1	1		3	4	5	6	7	0	1	2	3	2	1	0	7	6	5	4
1	0	0		4	5	6	7	0	1	2	3	4	5	6	7	0	1	2	3
1	0	1		5	6	7	0	1	2	3	4	5	4	7	6	1	0	3	2
1	1	0		6	7	0	1	2	3	4	5	6	7	4	5	2	3	0	1
1	1	1		7	0	1	2	3	4	5	6	7	6	5	4	3	2	1	0
-	0	0	4	0	1	2	3					0	1	2	3				
-	0	1		1	2	3	0					1	0	3	2				
-	1	0		2	3	0	1					2	3	0	1				
-	1	1		3	0	1	2					3	2	1	0				
-	-	0	2	0	1							0	1						
-	-	1		1	0							1	0						



OPERATIONAL DESCRIPTION

BANK ACTIVATE

The SDRAM has four independent banks. Each bank is activated by the ACT command with the bank addresses (BA0,1). A row is indicated by the row addresses (A0,12). The minimum activation interval between one bank and the other bank is tRRD. Multiple banks can be active state concurrently by issuing multiple ACT commands.

PRECHARGE

The PRE command deactivates the bank indicated by BA0,1. When multiple banks are active, the precharge all command (PREA, PRE + A10=H) is available to deactivate them at the same time.

After tRP from the precharge, an ACT command to the same bank can be issued. BA0-1 are **“DON’T CARE”** in this case.

READ

After tRCD from the bank activation, a READ command can be issued. 1st output data is available after the /CAS Latency from the READ, followed by (BL -1) consecutive data when the Burst Length is BL. The start address is specified by A0-A9,A11(x4), A0-9(X8), A0-8(X16) , and the address sequence of burst data is defined by the Burst Type. A READ command may be applied to any active bank, so the row precharge time (tRP) can be hidden behind continuous output data by interleaving the multiple banks. When A10 is high at a READ command, the auto-precharge (READA) is performed. Any command (READ, WRITE, PRE, TBST, ACT) to the same bank is inhibited till the internal precharge is complete. The internal precharge starts at BL after READA. The next ACT command can be issued after (BL + tRP) from the previous READA.

In any case, $tRCD+BL \geq tRASmin$ must be met.

Bank Activation and Precharge All (BL=4, CL=3)

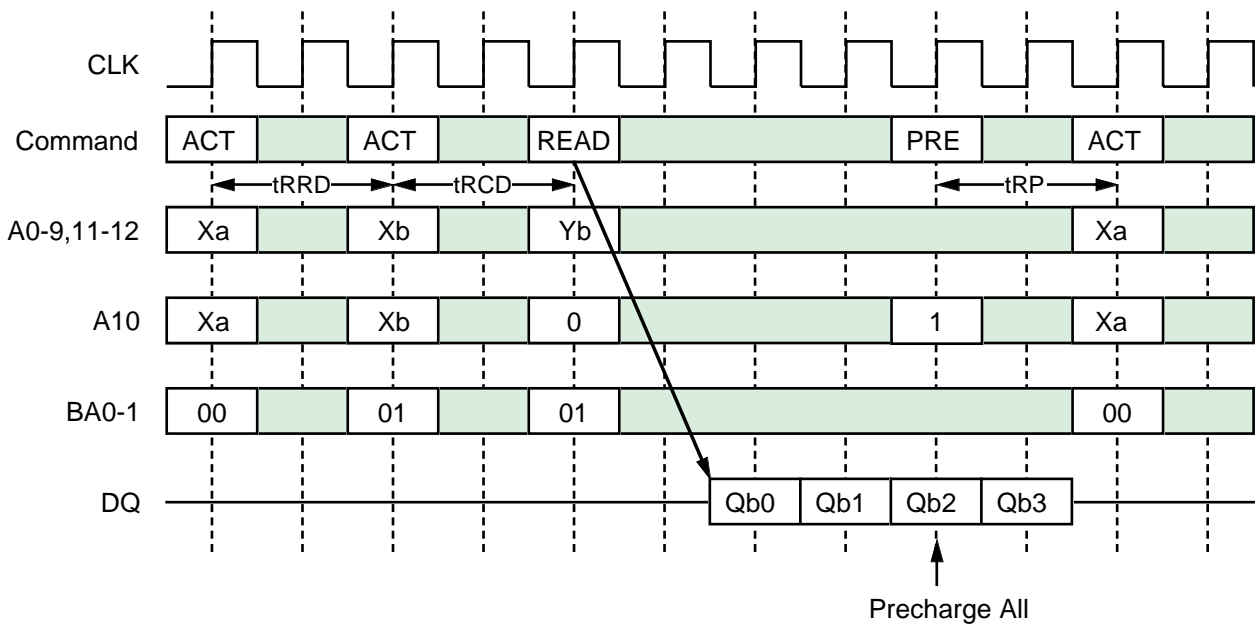



Z2V56S20BTP (4-BANK x 16,777,216-WORD x 4-BIT)
 Z2V56S30BTP (4-BANK x 8,388,608-WORD x 8-BIT)
 Z2V56S40BTP (4-BANK x 4,194,304-WORD x 16-BIT)

Multi Bank Interleaving Read (CL=2, BL=4)

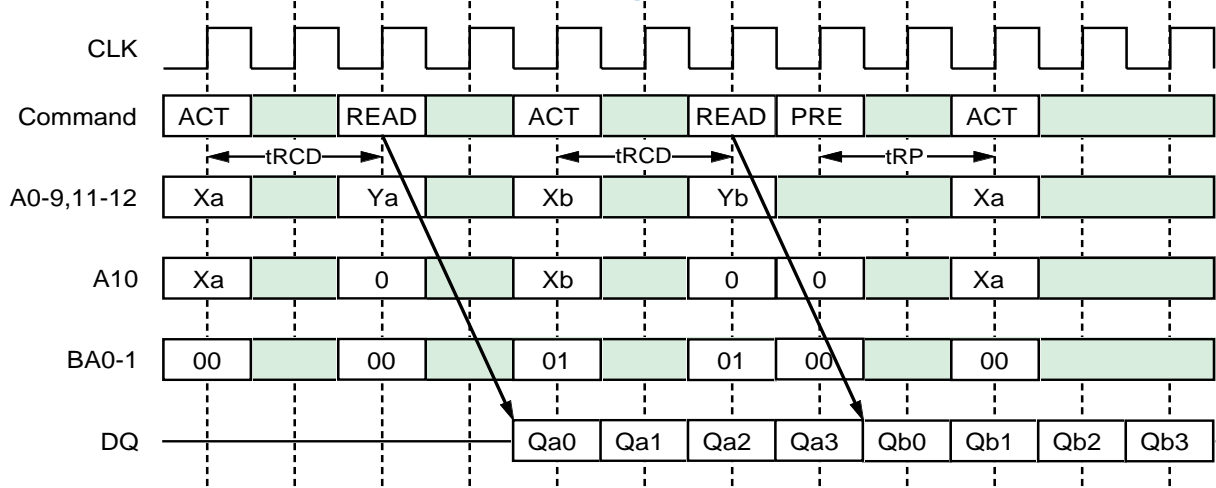

Read with Auto-Precharge (CL=2, BL=4)

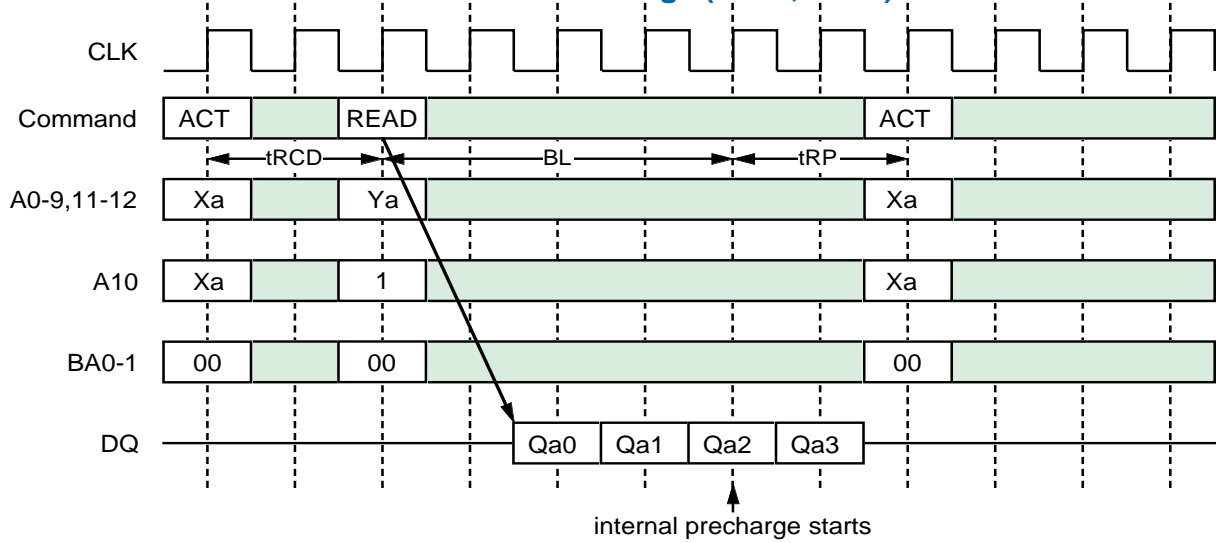

Auto-Precharge Timing (READ, BL=4)

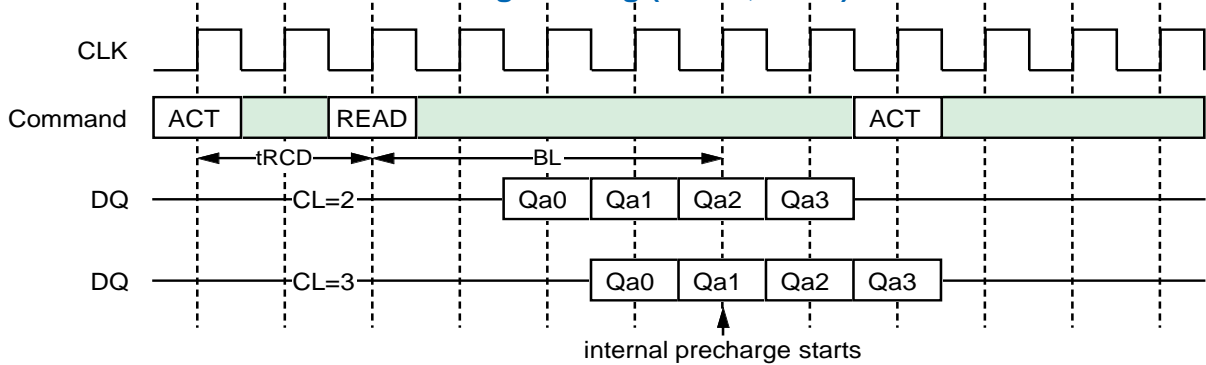



WRITE

A WRITE command can be issued to any active bank. The start address is specified by A0-9,11(x4),A0-9(x8), A0-8(x16). 1st input data is set at the same cycle as the WRITE. The consecutive data length to be write is defined by the Burst Length. The address sequence of burst data is defined by Burst Type. Minmum delay time of a WRITE command after an ACT command to the same bank is tRCD. From the last input data to the PRE command , the write recovery time (tWR) is

required. When A10 is high at a WRITE command , auto-precharge (WRITEEA) is performed. Any command (READ,WRITE,PRE,ACT,TBST) to the same bank is inhibited till the internal precharge is complete. The internal precharge starts at tWR after the last input data cycle . The next ACT command can be issued after (BL+tWR-1+tRP) from the previous WRITEEA. In any case, tRCD+BL+tWR-1 ≥ tRASmin must be met.

Write (BL=4)

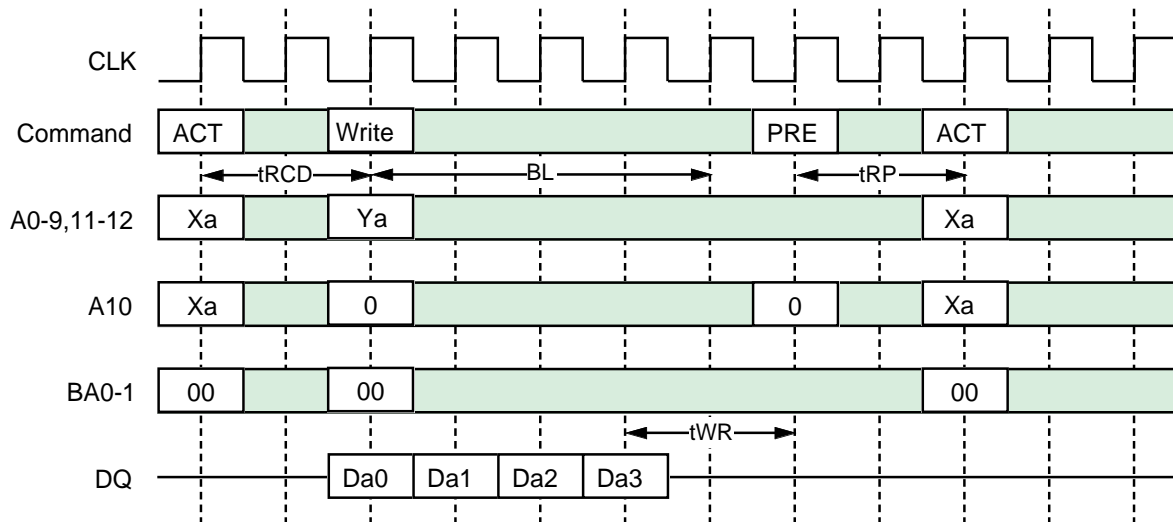

Write with Auto-Precharge (BL=4)

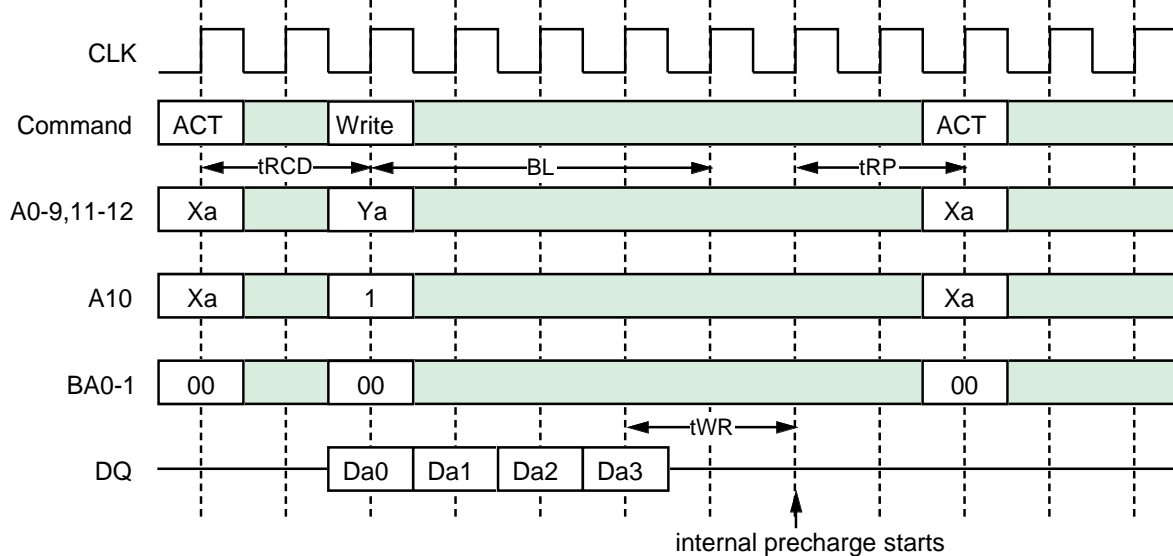



BURST INTERRUPTION

[Read Interrupted by Read]

Burst read operation can be interrupted by new read of any bank. Random column access is allowed. READ to READ interval is minimum 1 CLK.

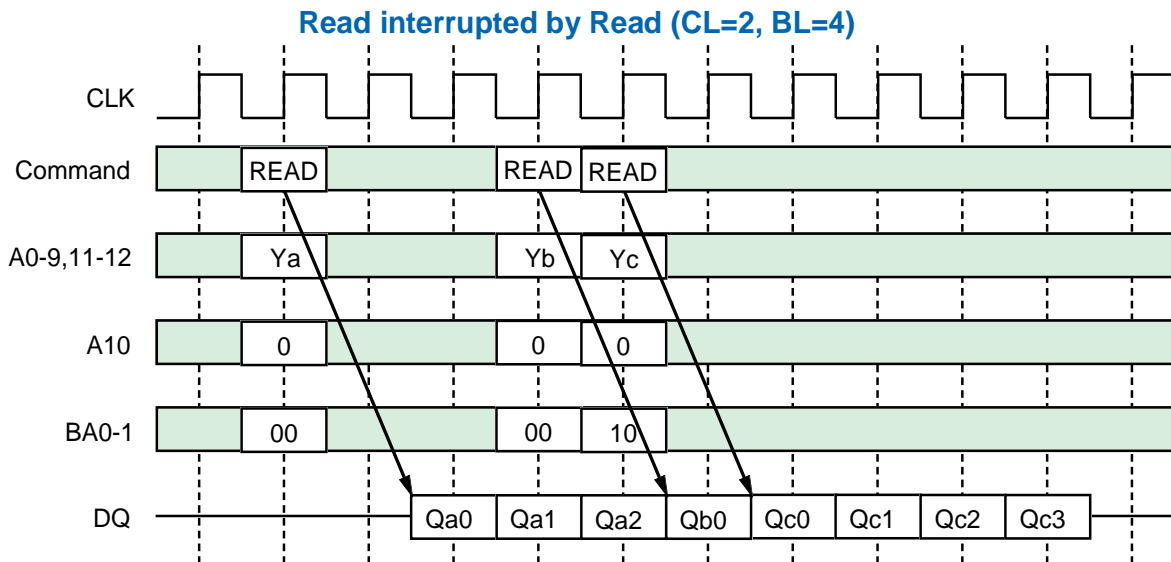

[Read Interrupted by Write]

Burst read operation can be interrupted by write of any bank. Random column access is allowed. In this case, the DQ should be controlled adequately by using the DQM to prevent the bus contention. The output is disabled automatically 2 cycle after WRITE assertion.

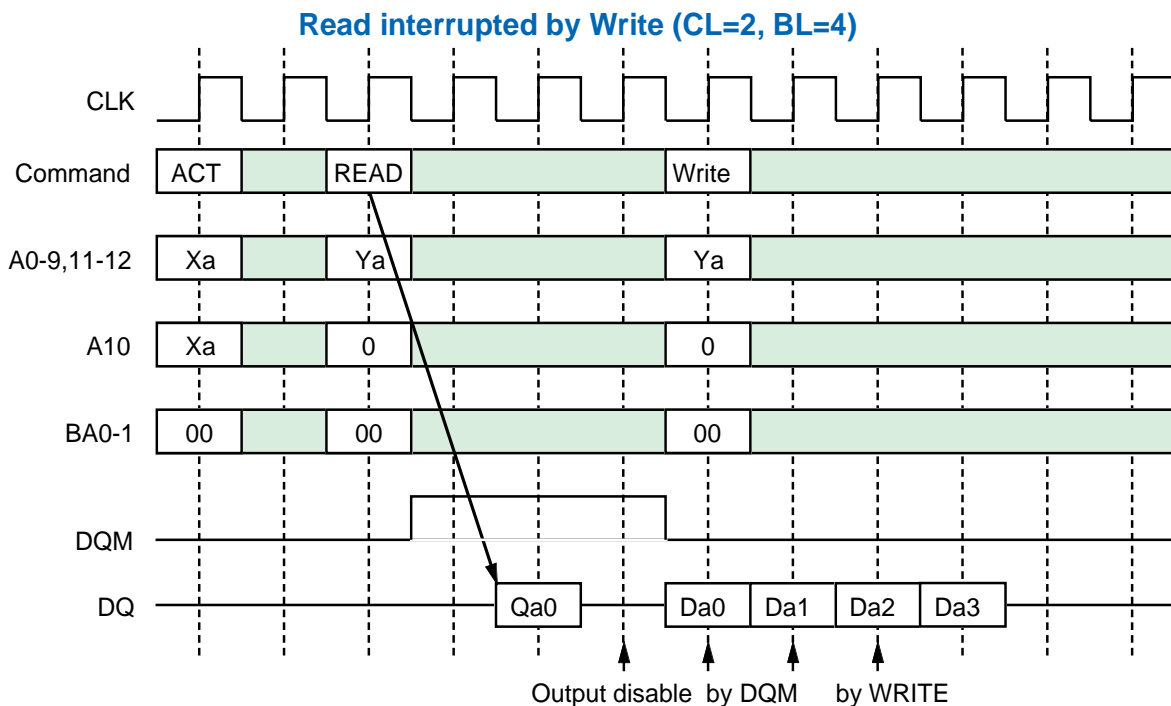



[Read Interrupted by Precharge]

Burst read operation can be interrupted by precharge of the same bank. READ to PRE interval is minimum 1 CLK. A PRE command to output disable latency is equivalent to the /CAS Latency. As a result, READ to PRE interval determines valid data length to be output. PRE interval determines valid data length to be output. The figure below shows examples of BL=4.

Read interrupted by Precharge (BL=4)

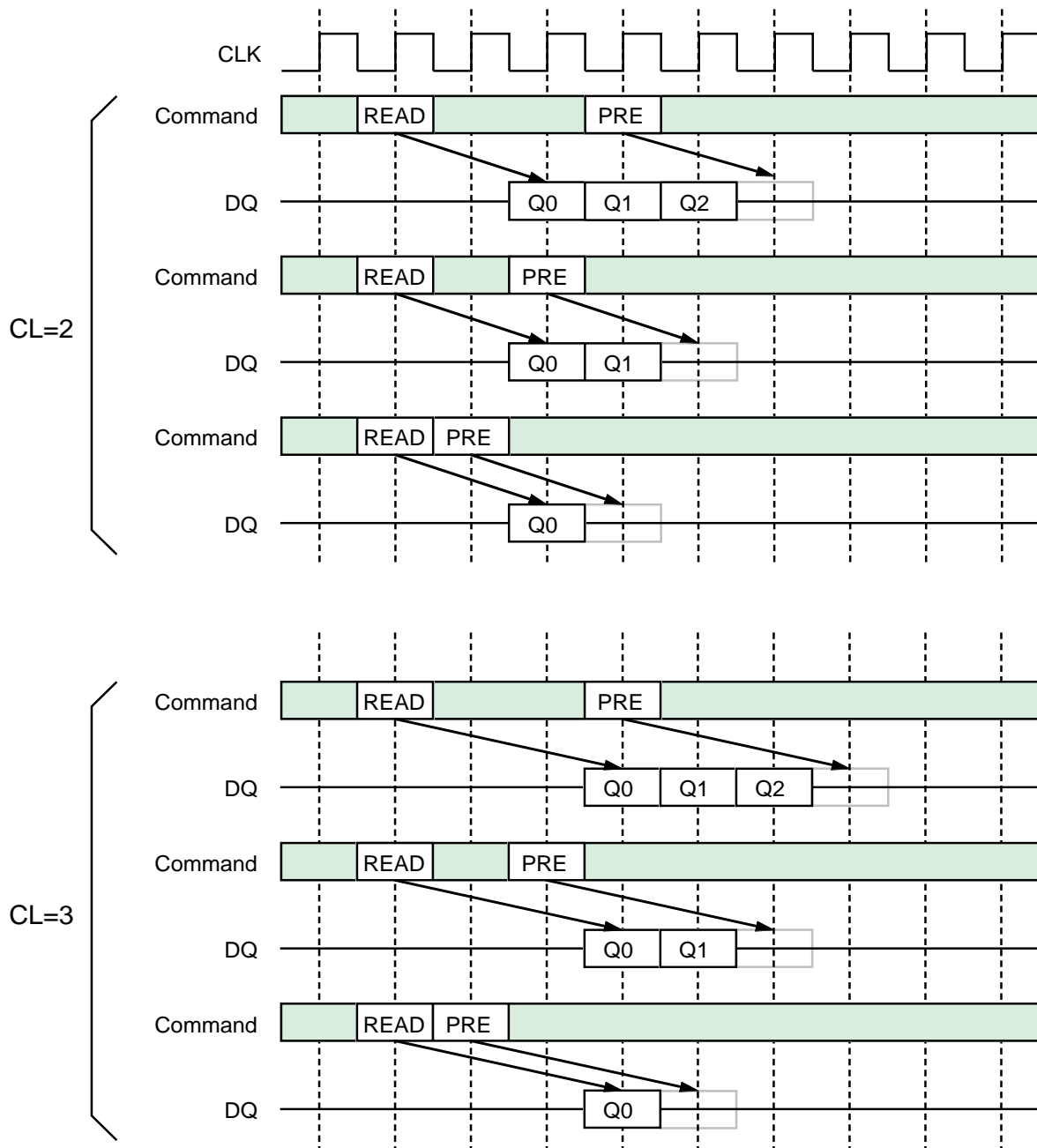



[Read Interrupted by Burst Terminate]

Similarly to the precharge, a burst terminate command can interrupt the burst read operation and disable the data output. The terminated bank remains active.

READ to TBST interval is minimum 1 CLK. A TBST command to output disable latency is equivalent to the /CAS Latency.

Read interrupted by Terminate (BL=4)

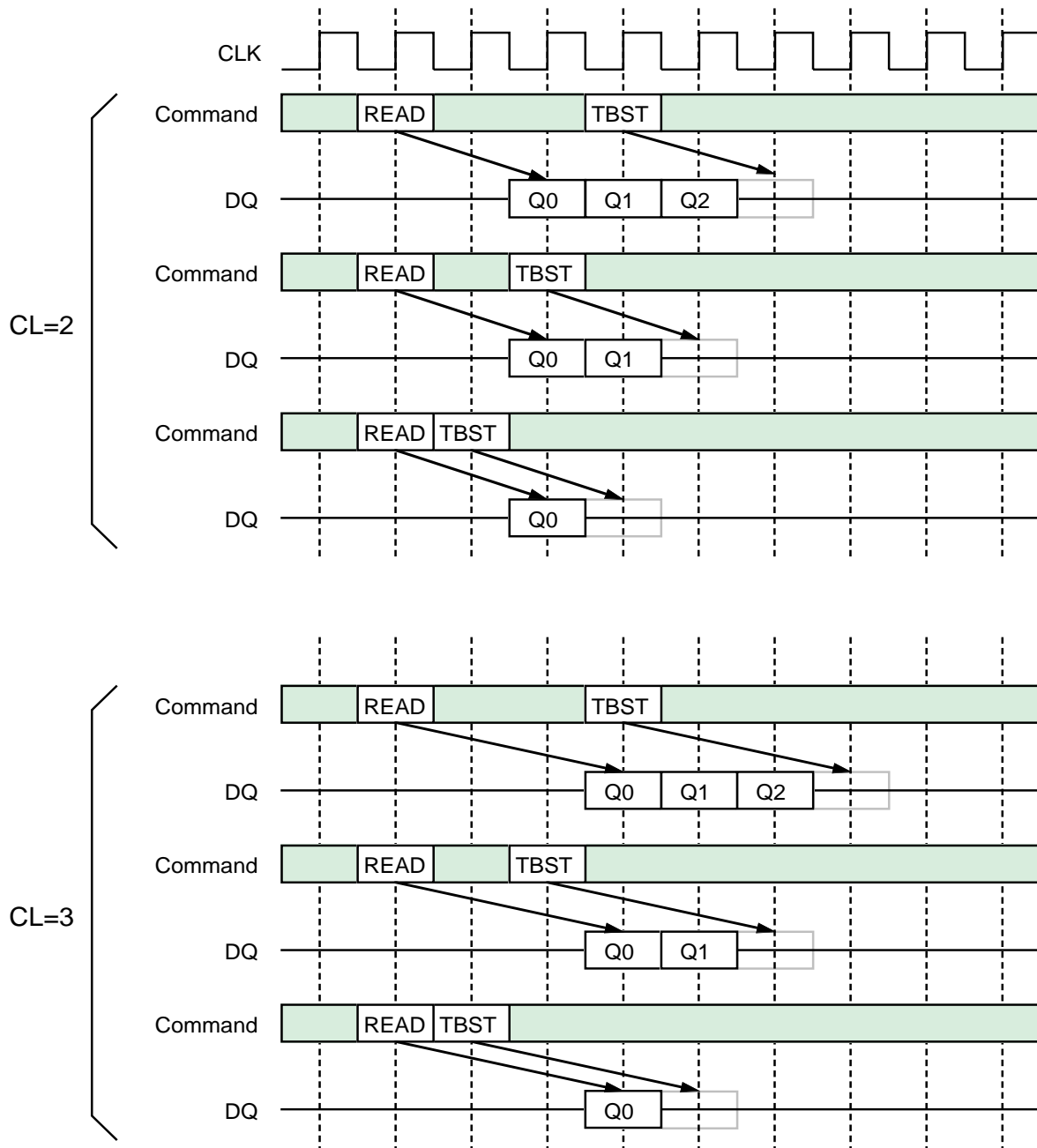



[Write Interrupted by Write]

Burst write operation can be interrupted by new write of any bank. Random column access is allowed. WRITE to WRITE interval is minimum 1 CLK.

Write interrupted by Write (BL=4)

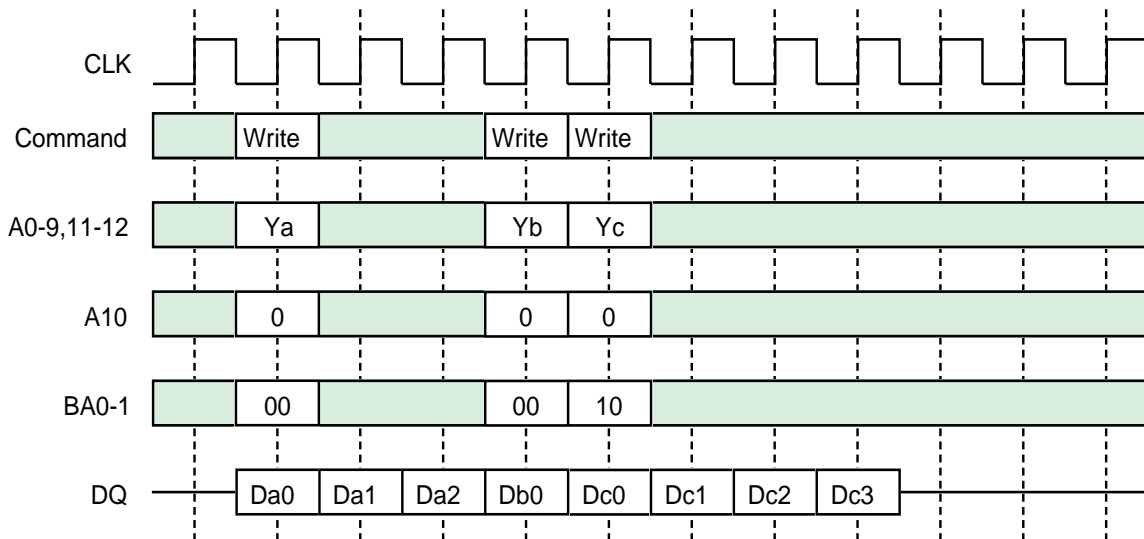

[Write Interrupted by Read]

Burst write operation can be interrupted by read of the same or the other bank. Random column access is allowed. WRITE to READ interval is minimum 1 CLK. The input data on DQ at the interrupting READ cycle is "don't care".

Write interrupted by Read (CL=2, BL=4)

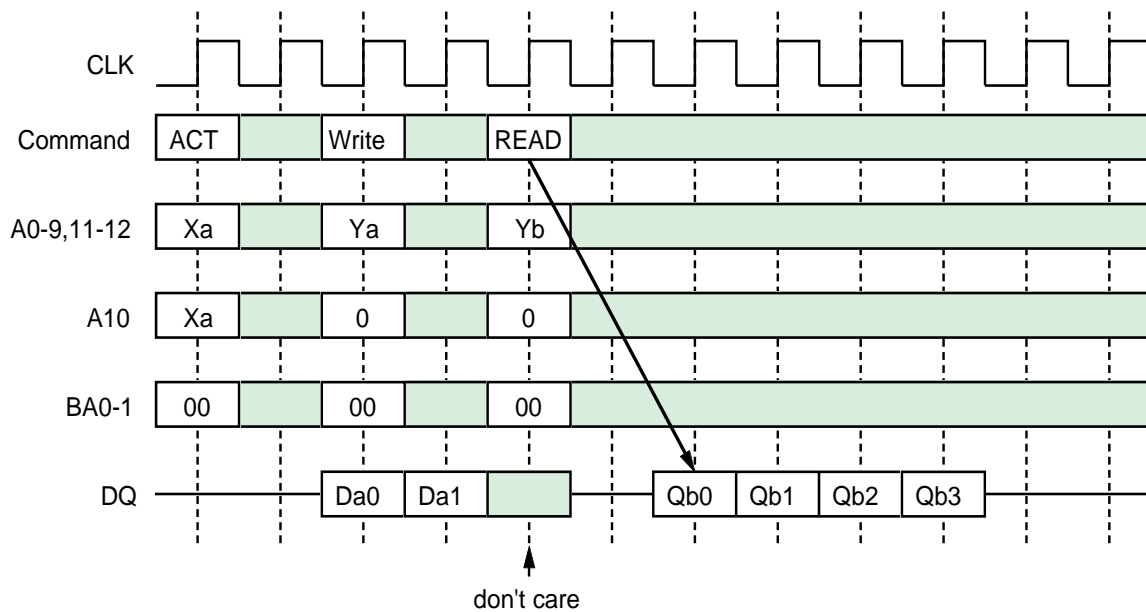



[Write Interrupted by Precharge]

Burst write operation can be interrupted by precharge of the same bank. Write recovery time(t_{WR}) is required from the last data to PRE command. During write recovery, data inputs must be masked by DQM.

Write interrupted by Precharge (BL=4)

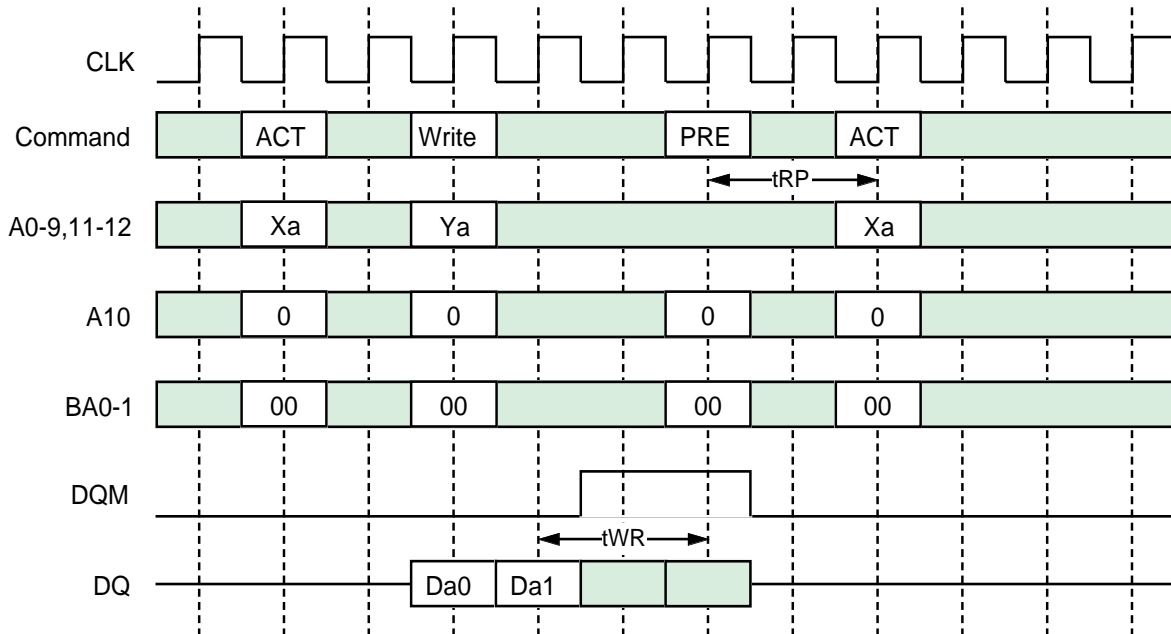

[Write Interrupted by Burst Terminate]

Burst terminate command can terminate burst write operation. In this case, the write recovery time is not required and the bank remains active. WRITE to TBST interval is minimum 1 CLK.

Write interrupted by Terminate (BL=4)

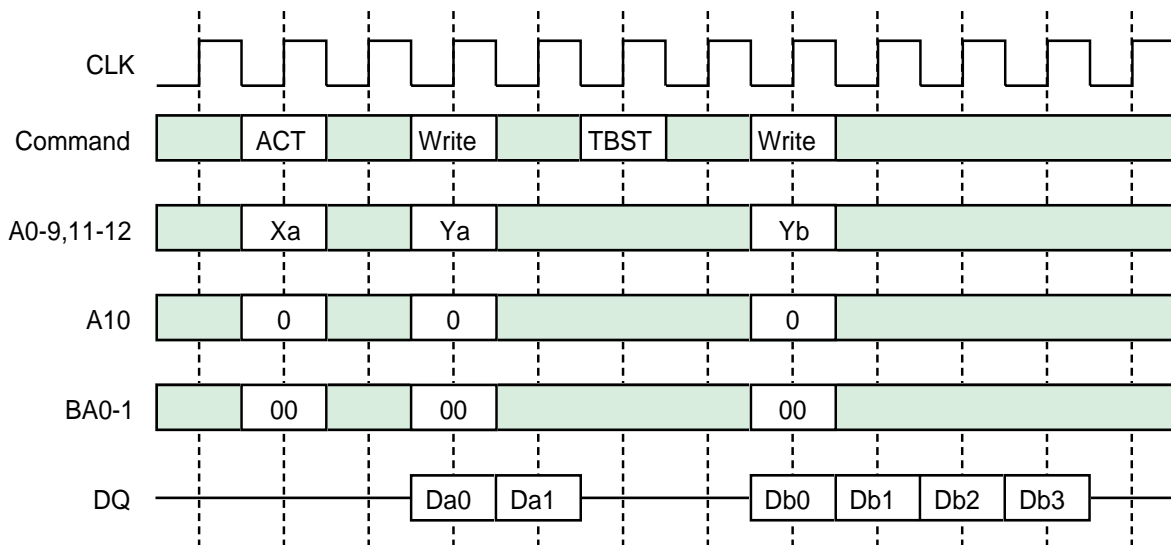



[Write with Auto-Precharge Interrupted by Write or Read to another Bank]

Burst write with auto-precharge can be interrupted by write or read to another bank. Next ACT command can be issued after $(BL+tWR+1+tRP)$ from the WRITEEA. Auto-precharge interruption by a command to the same bank is inhibited.

WRITEEA interrupted by WRITE to another bank (BL=4)

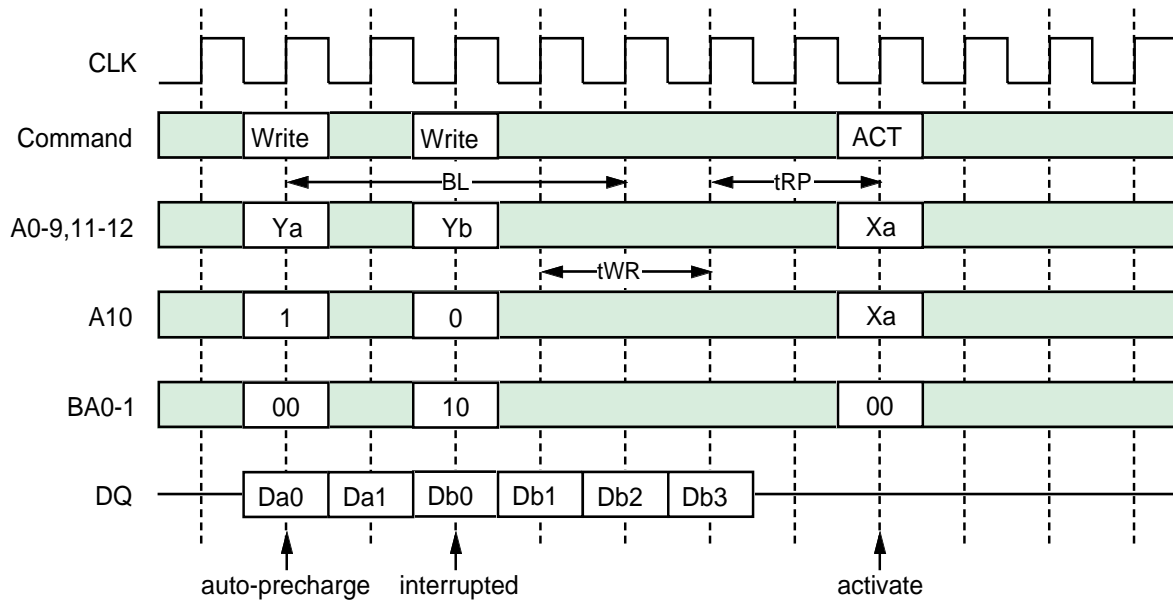

WRITEEA interrupted by READ to another bank (CL=2, BL=4)

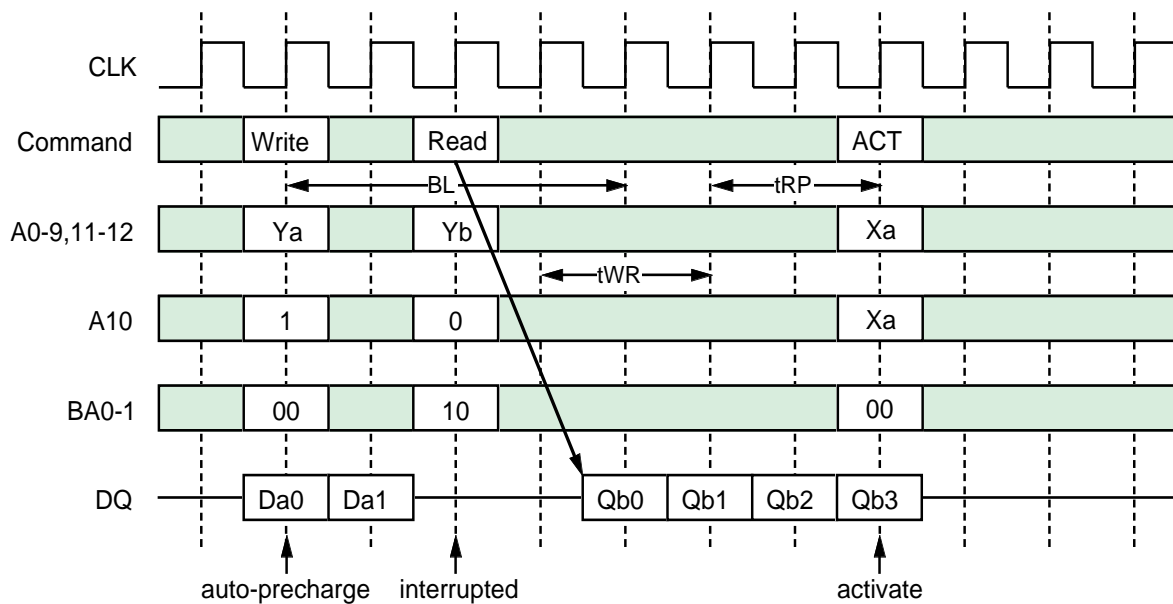

[Read with Auto-Precharge Interrupted by Read to another Bank]

Burst write with auto-precharge can be interrupted by write or read to another bank. Next ACT command can be issued after (BL+tRP) from the READA. Auto-precharge interruption by a command to the same bank is inhibited.

READA interrupted by READ to another bank (CL=2, BL=4)

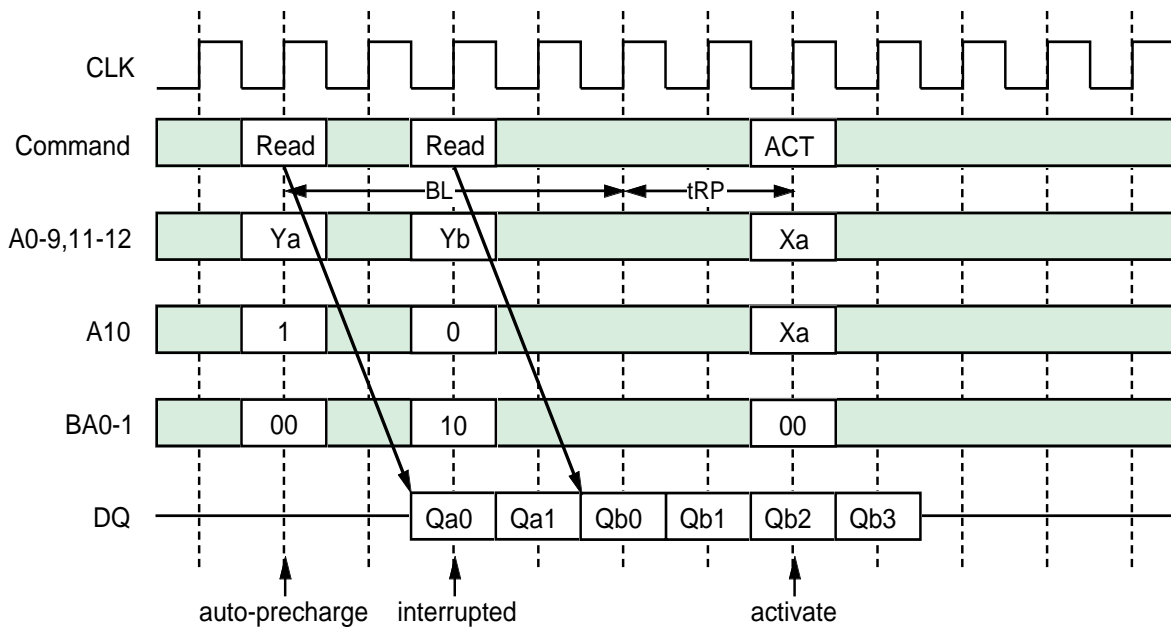

[Full Page Burst]

Full page burst length is available for only the sequential burst type. Full page burst read or write is repeated until a Precharge or a Burst Terminate command is issued. In case of the full page burst, a read or write with auto-precharge command is illegal.

[Single Write]

When single write mode is set, burst length for write is always one, independently of Burst Length defined by (A2-0).

AUTO REFRESH

Single cycle of auto-refresh is initiated with a REFA (/CS= /RAS= /CAS= L, /WE= /CKE= H) command. The refresh address is generated internally. 8192 REFA cycles within 64ms refresh 256M bit memory cells. The auto-refresh is performed on 4 banks

concurrently. Before performing an auto-refresh, all banks must be in the idle state. Auto-refresh to auto-refresh interval is minimum tRFC. Any command must not be supplied to the device before tRFC from the REFA command.

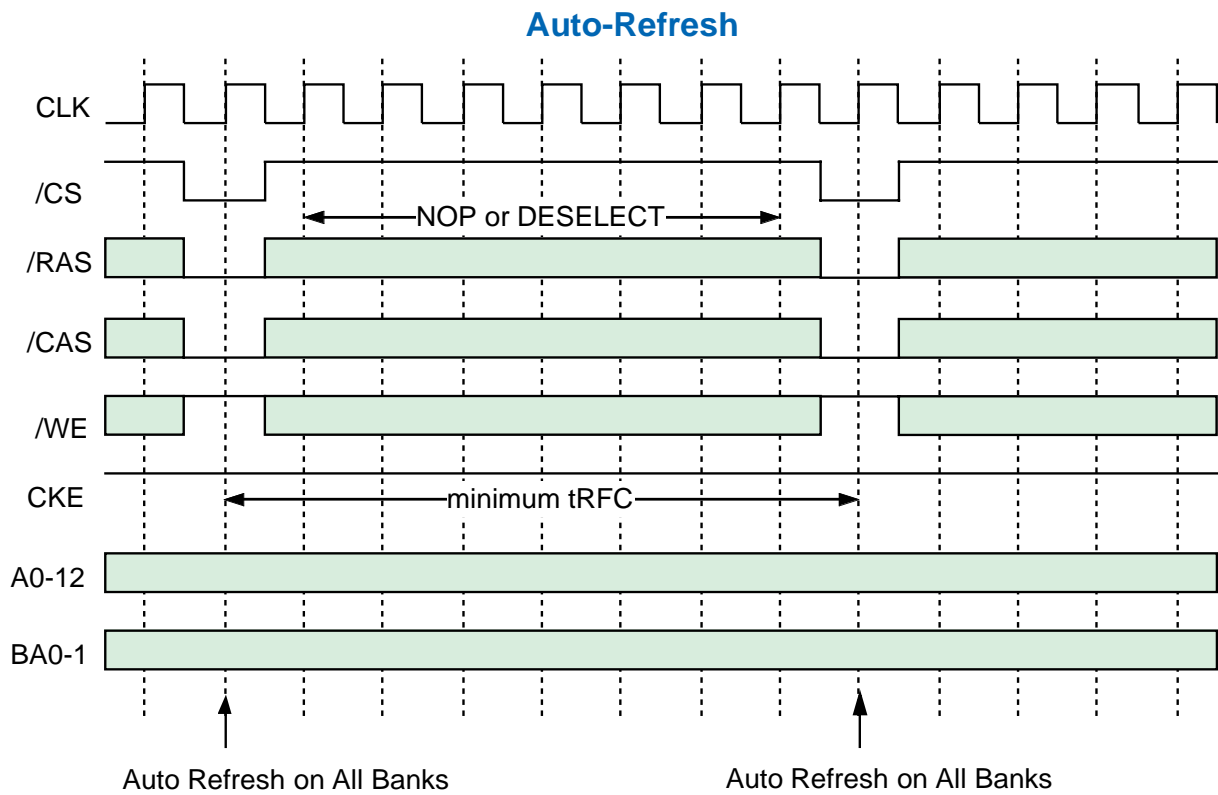

SELF REFRESH

Self-refresh mode is entered by issuing a REFS command (/CS= /RAS= /CAS= L, /WE= H, CKE= L). Once the self-refresh is initiated, it is maintained as long as CKE is kept low. During the self-refresh mode, CKE is asynchronous and the only enabled input. All other inputs including CLK are disabled and ignored, so that power consumption due to synchro-

nous inputs is saved. To exit the self-refresh, supplying stable CLK inputs, asserting DESEL or NOP command and then asserting CKE=H. After tRFC from the 1st CLK edge following CKE=H, all banks are in the idle state and a new command can be issued, but DESEL or NOP commands must be asserted till then.

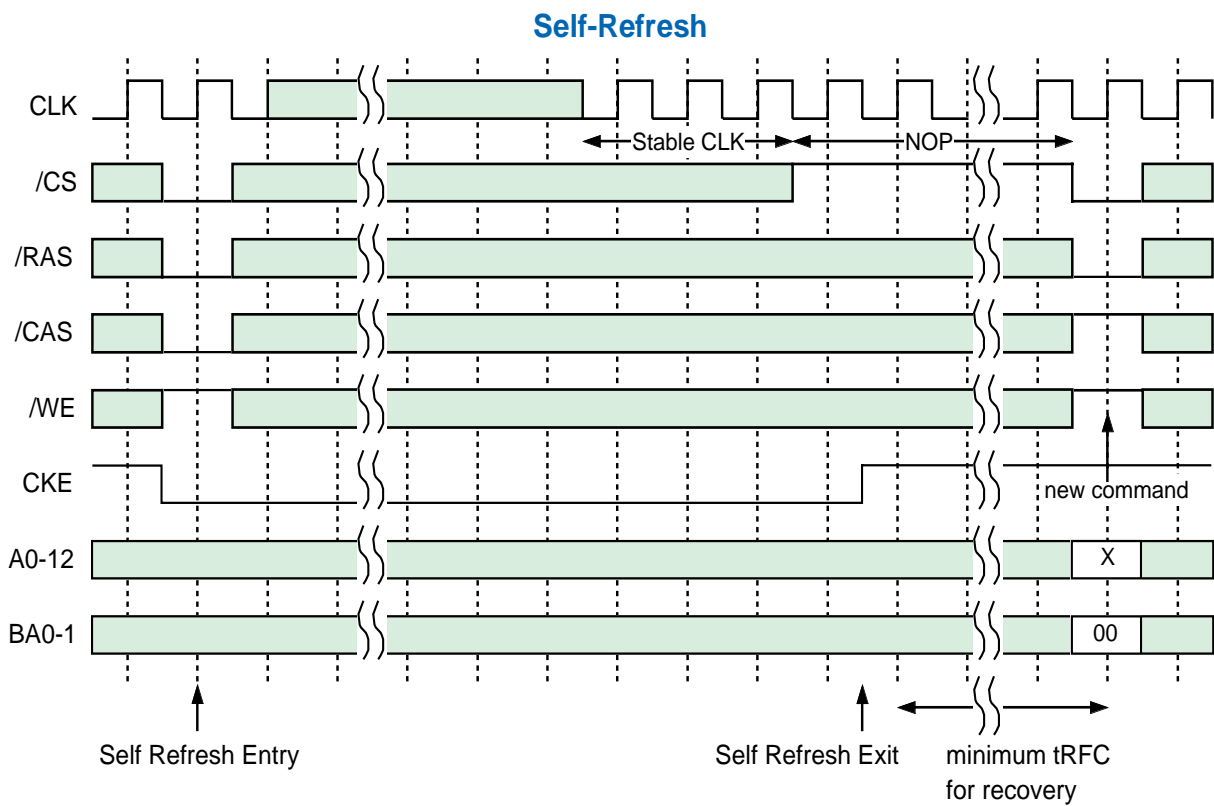



CLK SUSPEND

CKE controls the internal CLK at the following cycle. Figure below shows how CKE works. By negating CKE, the next internal CLK is suspended. The purpose of CLK suspend is power down, output suspend or input

suspend. CKE is a synchronous input except during the self-refresh mode. CLK suspend can be performed either when the banks are active or idle. A command at the suspended cycle is ignored.

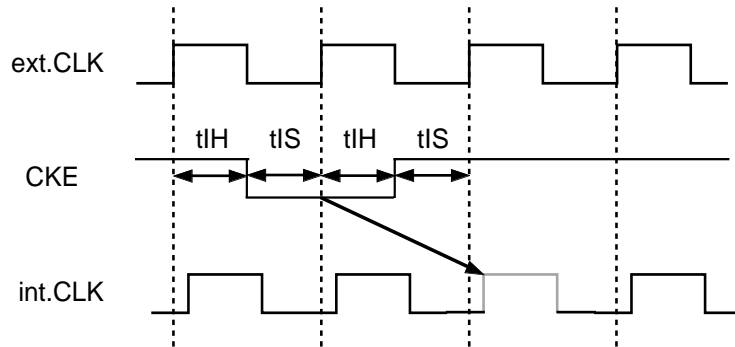

Power Down by CKE

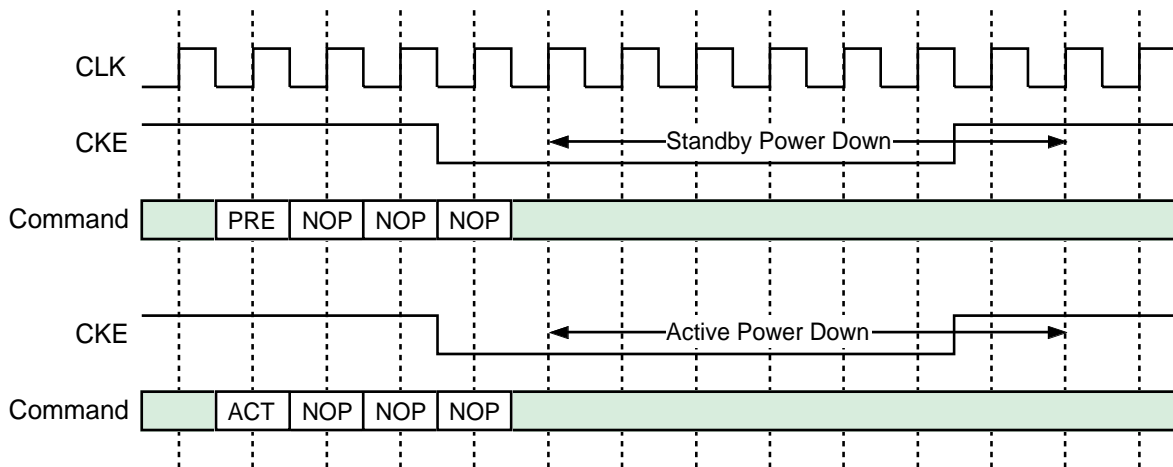

DQ Suspend by CKE

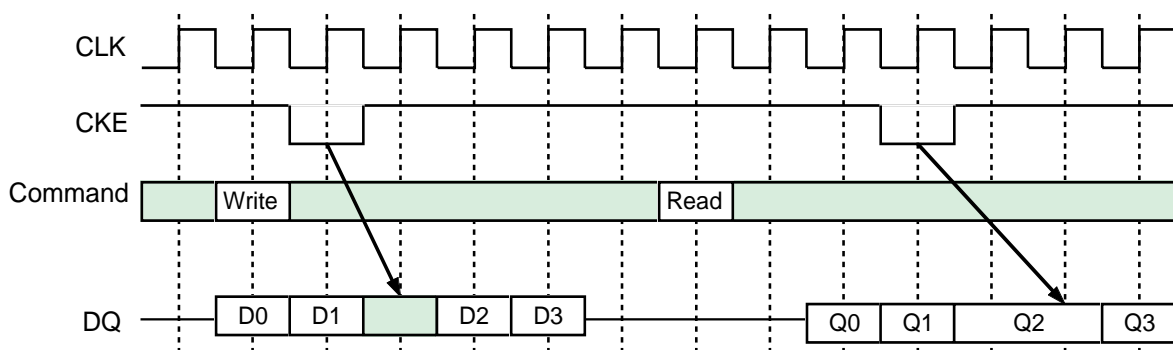

DQM CONTROL

DQM is a dual function signal defined as the data mask for writes and the output disable for reads. During writes, DQM(U,L) masks input data word by word. DQM(U,L) to write mask latency is 0. During reads, DQM(U,L) forces output to Hi-Z word by word. DQM(U,L) to output Hi-Z latency is 2.

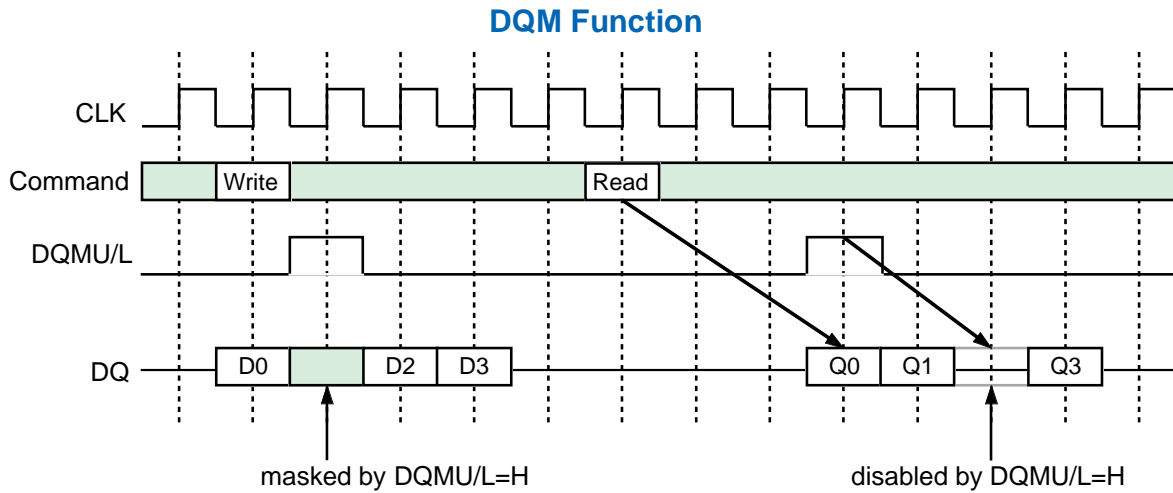



Z2V56S20BTP (4-BANK x 16,777,216-WORD x 4-BIT)
Z2V56S30BTP (4-BANK x 8,388,608-WORD x 8-BIT)
Z2V56S40BTP (4-BANK x 4,194,304-WORD x 16-BIT)

ABSOLUTE MAXIMUM RATINGS

Symbol	Parameter	Conditions	Ratings	Unit
Vdd	Supply Voltage	with respect to Vss	-0.5 - 4.6	V
VddQ	Supply Voltage for Output	with respect to VssQ	-0.5 - 4.6	V
VI	Input Voltage	with respect to Vss	-0.5 - 4.6	V
VO	Output Voltage	with respect to VssQ	-0.5 - 4.6	V
IO	Output Current		50	mA
Pd	Power Dissipation	Ta = 25 C	1000	mW
Topr	Operating Temperature		0 - 70	C
Tstg	Storage Temperature		-65 - 150	C

RECOMMENDED OPERATING CONDITIONS

(Ta=0 - 70 C ,unless otherwise noted)

Symbol	Parameter	Limits			Unit
		Min.	Typ.	Max.	
Vdd	Supply Voltage	3.0	3.3	3.6	V
Vss	Supply Voltage	0	0		V
VddQ	Supply Voltage for output	3.0	3.3	3.6	V
VssQ	Supply Voltage for output	0	0	0	V
VIH*1	High-Level Input Voltage all inputs	2.0		VddQ +0.3	V
VIL*2	Low-level Input Voltage all inputs	-0.3		0.8	V

CAPACITANCE

(Ta=0 -70 C,Vdd=VddQ=3.3±0.3 V,Vss=VssQ=0V,unless otherwise noted)

Symbol	Parameter	Test Condition	Limits (min.)	Limits (max.)		Unit
				-6/-7	-75/-8	
CI(A)	Input Capacitance, address pin	@ 1MHz 1.4V bias 200mV swing Vcc=3.3V	2.5	3.8	5.0	pF
CI(C)	Input Capacitance, contorl pin		2.5	3.8	5.0	pF
CI(K)	Input Capacitance, CLK pin		2.5	3.5	4.0	pF
CI/O	Input Capacitance, I/O pin		4.0	6.5	6.5	pF



Z2V56S20BTP (4-BANK x 16,777,216-WORD x 4-BIT)
Z2V56S30BTP (4-BANK x 8,388,608-WORD x 8-BIT)
Z2V56S40BTP (4-BANK x 4,194,304-WORD x 16-BIT)

AVERAGE SUPPLY CURRENT from Vdd

(Ta=0 - 70 C, Vdd=VddQ=3.3±0.3V, Vss=VssQ=0V, unless otherwise noted)

ITEM	Symbol		Organi- zation	Limits (max.)				Unit	Note	
				-6	-7	-75	-8			
Operating current	Icc1	tRC=min, tCLK=min BL=1, IOL=0mA	x4	100	100	100	95	mA	1	
			x8	110	110	110	100	mA		
			x16	130	130	130	120	mA		
Precharge Standby current in Non-Power down mode	Icc2N	CKE=VILmax tCLK=15ns	x4/x8/x16	20	20	20	20	mA	2,3	
	Icc2NS	CKE=VIHmin CLK=VILmax(fixed)	x4/x8/x16	15	15	15	15	mA	2,4	
Precharge Standby current in Power down mode	Icc2P	CKE=VIHmin tCLK=15ns(Note)	x4/x8/x16	2	2	2	2	mA	2	
	Icc2PS	CKE=VIHmin tCLK=VILmax(fixed)	x4/x8/x16	1	1	1	1	mA		
Active Standby current	Icc3N	CKE=/CS=VIHmin tCLK=15ns(Note)	x4/x8/x16	30	30	30	30	mA	3,5	
	Icc3NS	CKE=VIHmin tCLK=VILmax(fixed)	x4/x8/x16	20	20	20	20	mA	4,5	
Burst current	Icc4	All Bank Active tCLK = min BL=4, CL=3, IOL=0mA	x4	140	140	140	110	mA	5	
			x8	150	150	150	120	mA		
			x16	160	160	160	130	mA		
Auto-refresh current	Icc5	tRC=min, tCLK=min	x4/x8/x16	160	160	160	160	mA		
Self-refresh current	Icc6	CKE < 0.2V	x4/x8/x16	6,7,75,8	3	3	3	3	mA	

NOTE:

- 1.address are changed 3 times during tRC , only 1 bank is active & all other banks are idle
- 2.all banks are idle
- 3.input signals are changed one time during 3x tCLK
- 4.input signals are stable
- 5.all banks are active

AC OPERATING CONDITIONS AND CHARACTERISTICS

(Ta=0 - 70 C, Vdd=VddQ=3.3±0.3V, Vss=VssQ=0V, unless otherwise noted)

Symbol	Parameter	Test Conditions	Limits		unit
			Min.	Max.	
VOH (DC)	High-Level Output Voltage (DC)	IOH=-2mA	2.4		V
VOL (DC)	Low-level Output Voltage (DC)	IOL= 2mA		0.4	V
IOZ	Off-state Output Current	Q floating VO=0 -- VddQ	-10	10	µA
Ii	Input Current	VIH = 0 -- VddQ +0.3V	-10	10	µA



Z2V56S20BTP (4-BANK x 16,777,216-WORD x 4-BIT)
Z2V56S30BTP (4-BANK x 8,388,608-WORD x 8-BIT)
Z2V56S40BTP (4-BANK x 4,194,304-WORD x 16-BIT)

AC TIMING REQUIREMENTS

(Ta=0 - 70 C, Vdd=VddQ=3.3±0.3V, Vss=VssQ=0V, unless otherwise noted)

Input Pulse Levels:0.8V-2.0V

Input Timing Measurement Level:1.4V

Symbol	Parameter	Limits								Unit	
		-6		-7		-75		-8			
		Min.	Max.	Min.	Max.	Min.	Max.	Min.	Max.		
tCLK	CLK cycle time	CL=2	-		-		10		10		ns
		CL=3	6		7		7.5		8		ns
tCH	CLK High pulse width	2		2.5		2.5		3		ns	
tCL	CLK Low pulse width	2		2.5		2.5		3		ns	
tT	Transition time of CLK	1	10	1	10	1	10	1	10	ns	
tIS	Input Setup time (all inputs)	1.8		1.8		1.8		2		ns	
tIH	Input Hold time (all inputs)	1		1		1		1		ns	
tRC	Row Cycle time	60		63		67.5		70		ns	
tRFC	Refresh Cycle Time	60		70		75		80		ns	
tRCD	Row to Column Delay	15		20		20		20		ns	
tRAS	Row Active time	42	120K	45	120K	45	120K	48	120K	ns	
tRP	Row Precharge time	15		20		20		20		ns	
tWR	Write Recovery time	12		14		15		20		ns	
tRRD	Act to Act Delay time	12		14		15		20		ns	
tRSC	Mode Register Set Cycle time	12		14		15		20		ns	
tREF	Refresh Interval time		7.8		7.8		7.8		7.8	us	

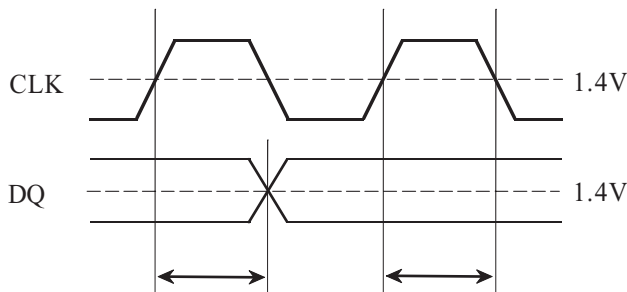

Any AC timing is referenced to the input signal passing through 1.4V.



Z2V56S20BTP (4-BANK x 16,777,216-WORD x 4-BIT)
Z2V56S30BTP (4-BANK x 8,388,608-WORD x 8-BIT)
Z2V56S40BTP (4-BANK x 4,194,304-WORD x 16-BIT)

SWITCHING CHARACTERISTICS

(Ta=0 - 70 C, Vdd=VddQ=3.3±0.3V, Vss=VssQ=0V, unless otherwise noted)

Symbol	Parameter	Limits								Unit	Note
		-6		-7		-75		-8			
		Min.	Max.	Min.	Max.	Min.	Max.	Min.	Max.		
tAC	Access time from CLK	CL=2					6		6	ns	*1
		CL=3		5		5.4		5.4		6	
tOH	Output Hold time from CLK	CL=2				3		3		ns	
		CL=3	2.5		2.7		3		3	ns	
tOLZ	Delay time, output low-impedance from CLK	0		0		0		0		ns	
tOHZ	Delay time, output high-impedance from CLK	2.5	5	2.7	5.4	3	5.4	3	6	ns	

NOTE:

1. If clock rising time is longer than 1ns, (tr/2-0.5ns) should be added to the parameter.

Output Load Condition

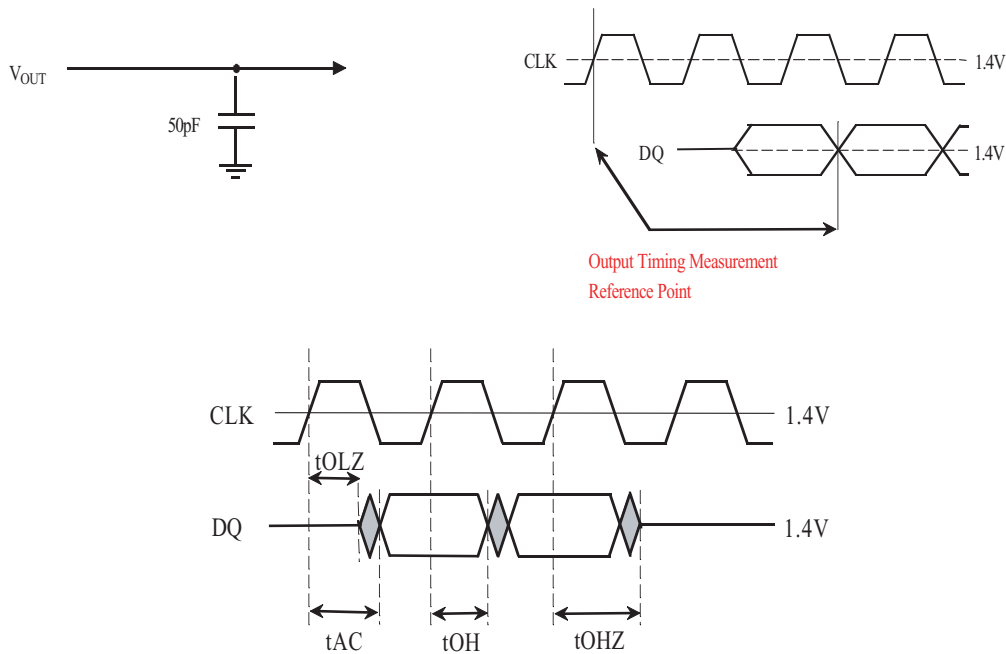



Z2V56S20BTP (4-BANK x 16,777,216-WORD x 4-BIT)
 Z2V56S30BTP (4-BANK x 8,388,608-WORD x 8-BIT)
 Z2V56S40BTP (4-BANK x 4,194,304-WORD x 16-BIT)

Burst Write (Single Bank) [BL=4]

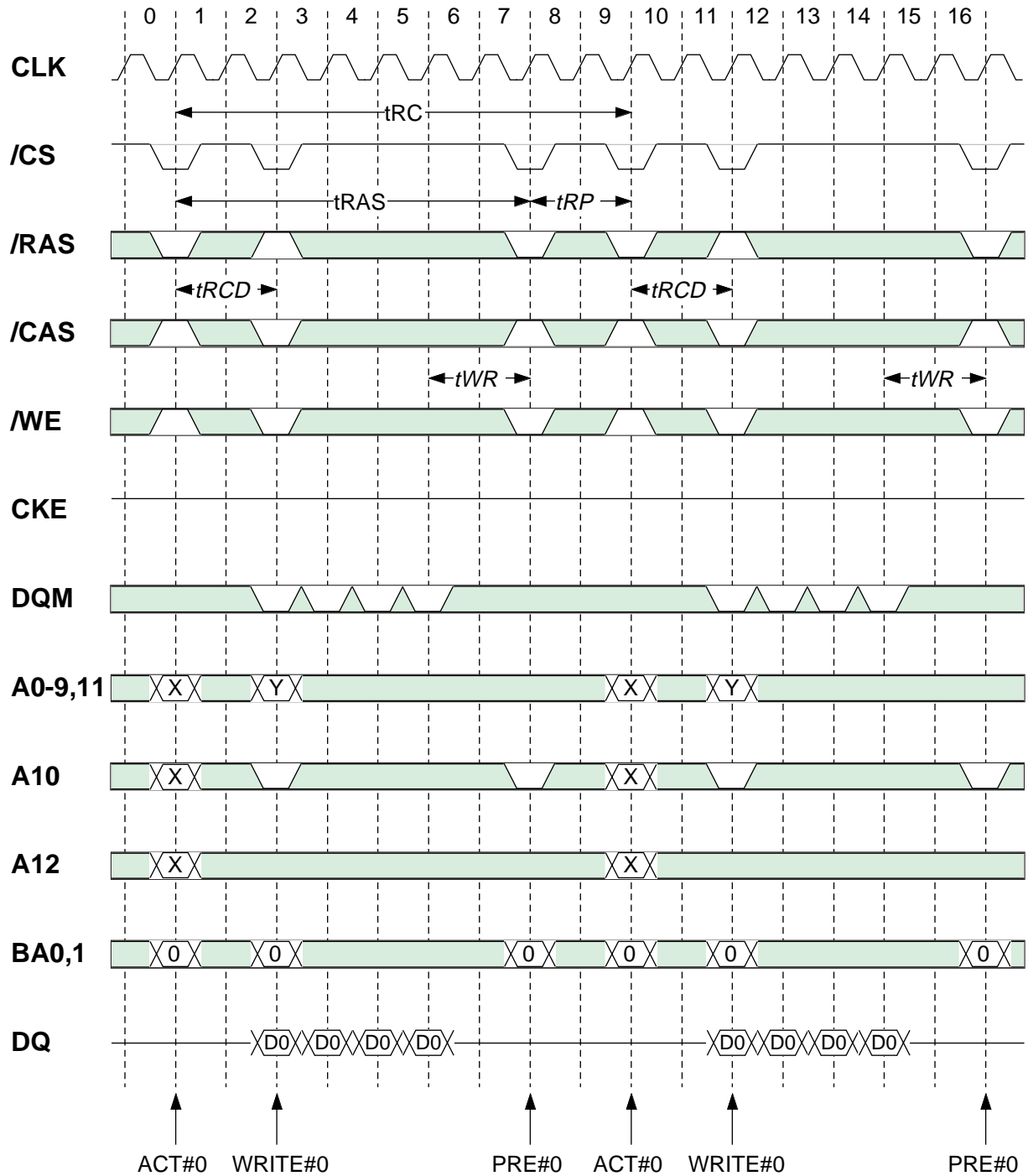

Italic parameter shows minimum case



Z2V56S20BTP (4-BANK x 16,777,216-WORD x 4-BIT)
 Z2V56S30BTP (4-BANK x 8,388,608-WORD x 8-BIT)
 Z2V56S40BTP (4-BANK x 4,194,304-WORD x 16-BIT)

Burst Write (Multi Bank) [BL=4]

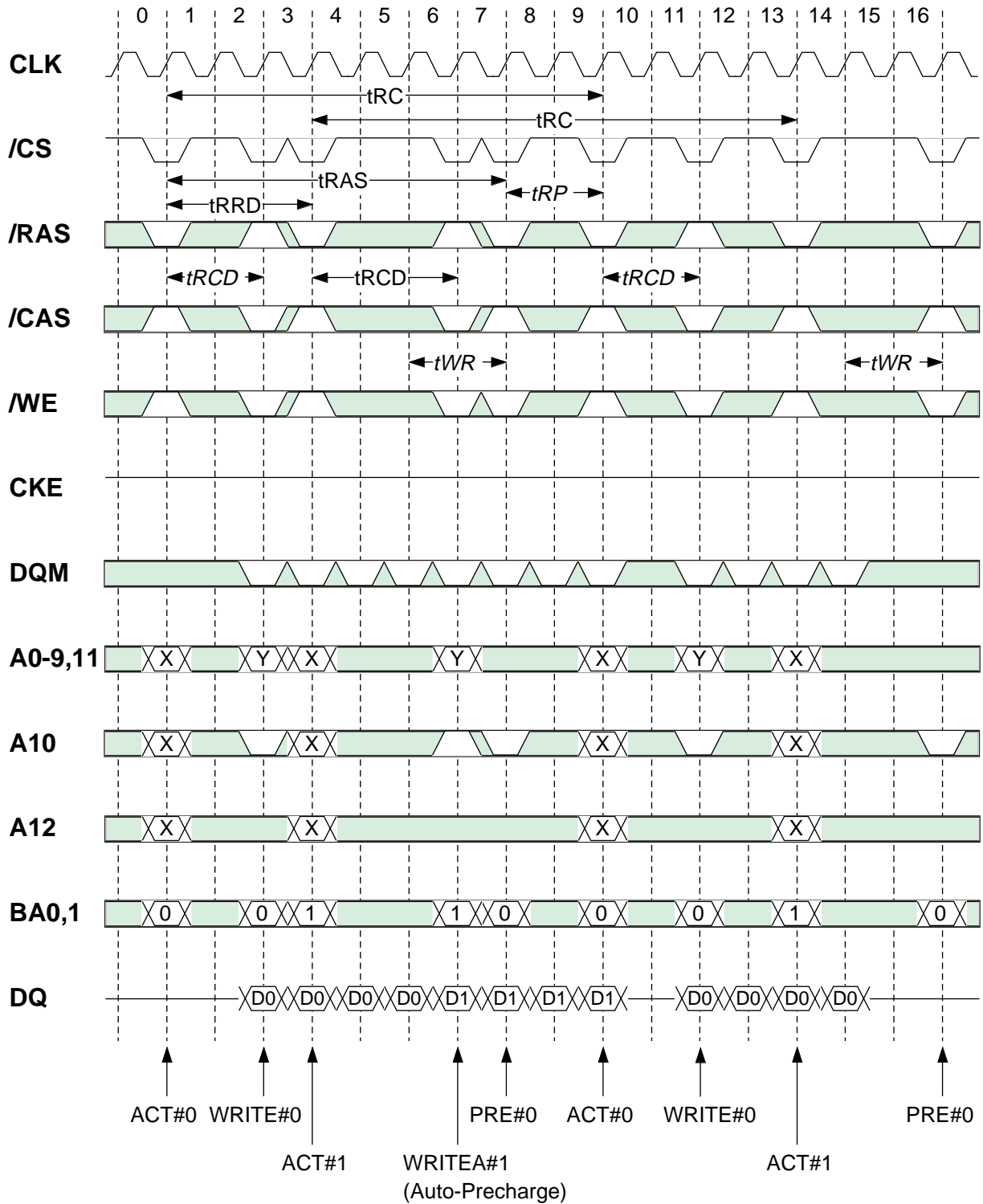

Italic parameter shows minimum case



Z2V56S20BTP (4-BANK x 16,777,216-WORD x 4-BIT)
 Z2V56S30BTP (4-BANK x 8,388,608-WORD x 8-BIT)
 Z2V56S40BTP (4-BANK x 4,194,304-WORD x 16-BIT)

Burst Read (Single Bank) [CL=2, BL=4]

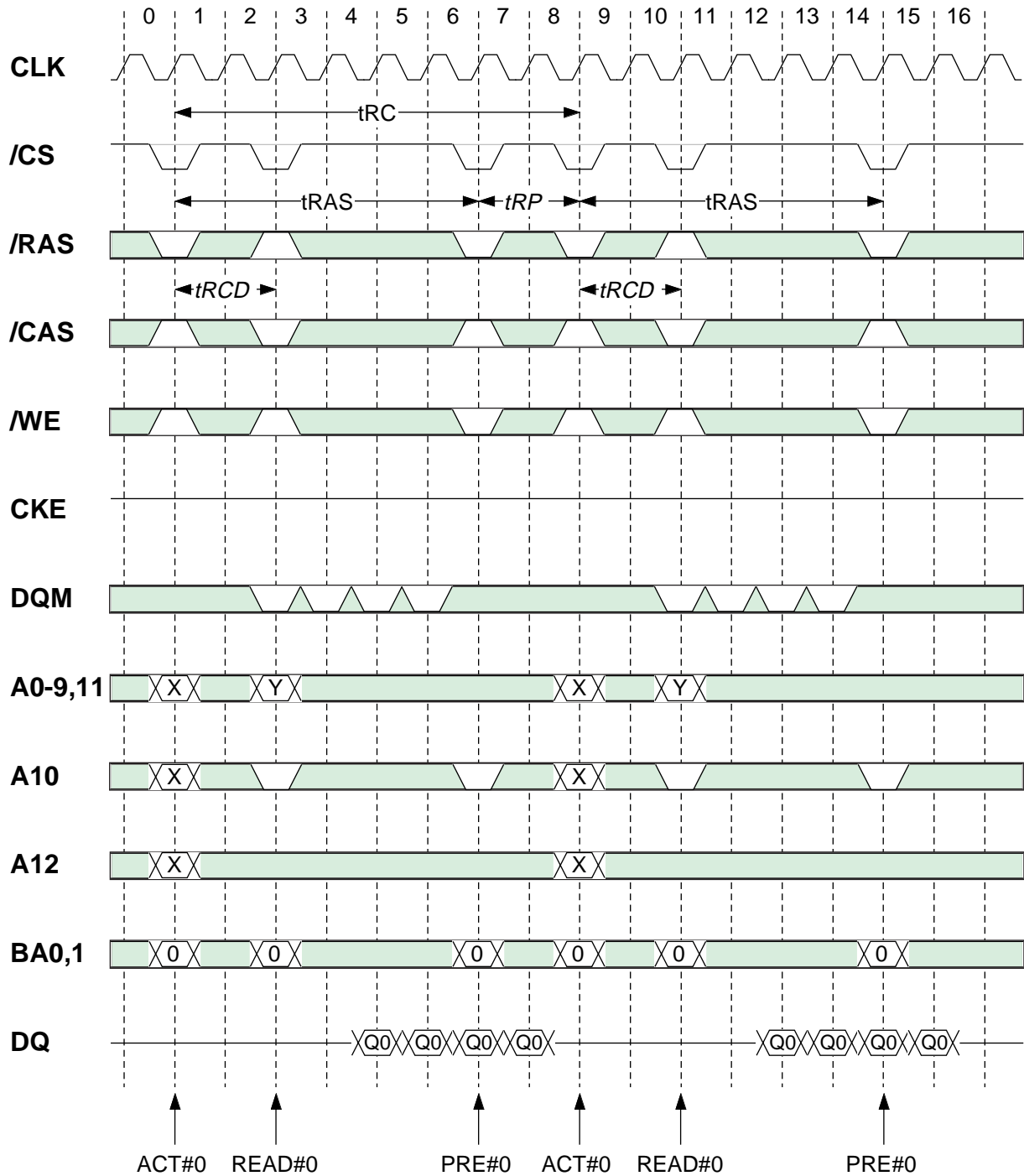

Italic paramater shows minimum case



Z2V56S20BTP (4-BANK x 16,777,216-WORD x 4-BIT)
 Z2V56S30BTP (4-BANK x 8,388,608-WORD x 8-BIT)
 Z2V56S40BTP (4-BANK x 4,194,304-WORD x 16-BIT)

Burst Read (Multi Bank) [CL=2, BL=4]

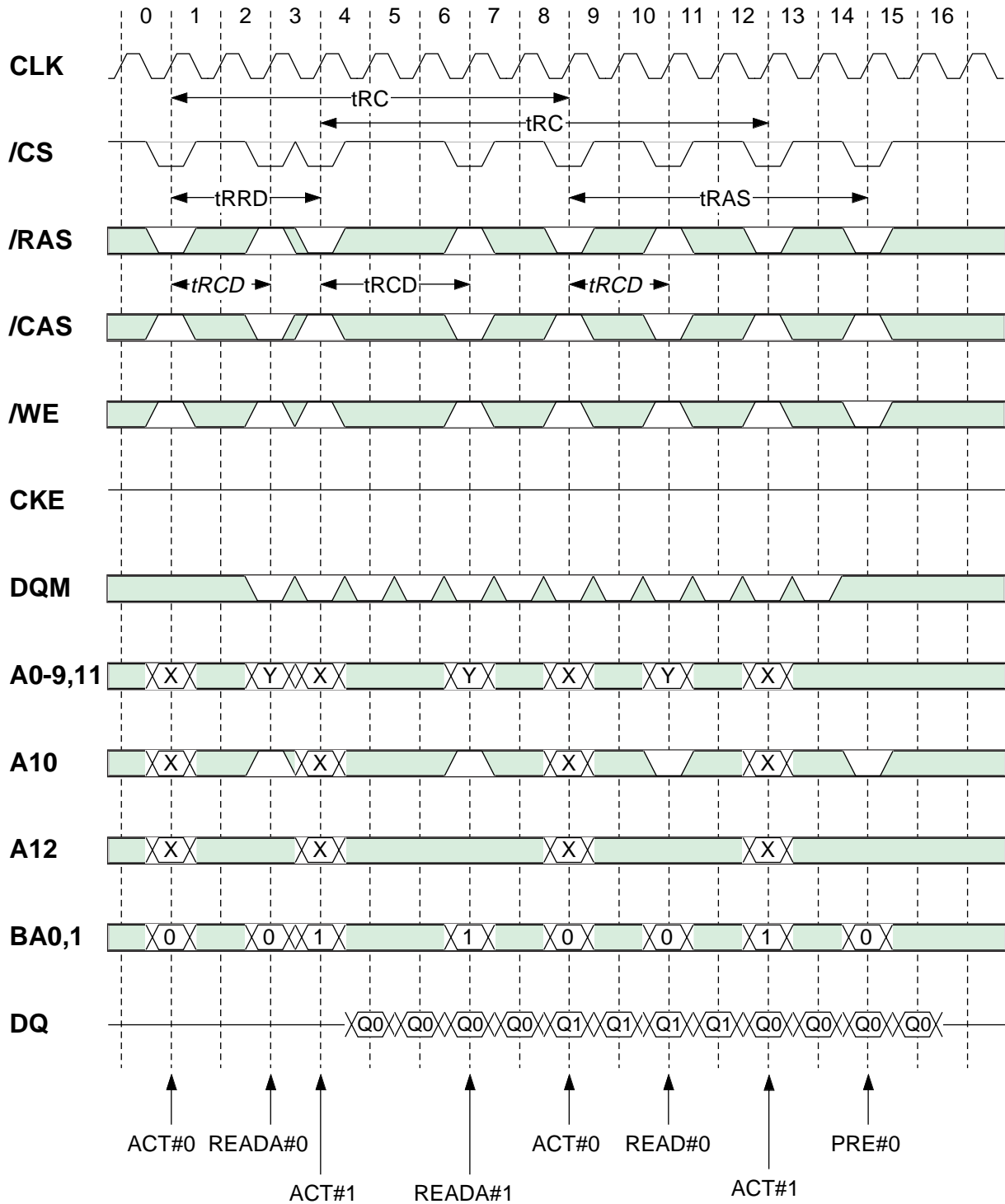

Italic parameter shows minimum case



Z2V56S20BTP (4-BANK x 16,777,216-WORD x 4-BIT)
 Z2V56S30BTP (4-BANK x 8,388,608-WORD x 8-BIT)
 Z2V56S40BTP (4-BANK x 4,194,304-WORD x 16-BIT)

Write Interrupted by Write [BL=4]

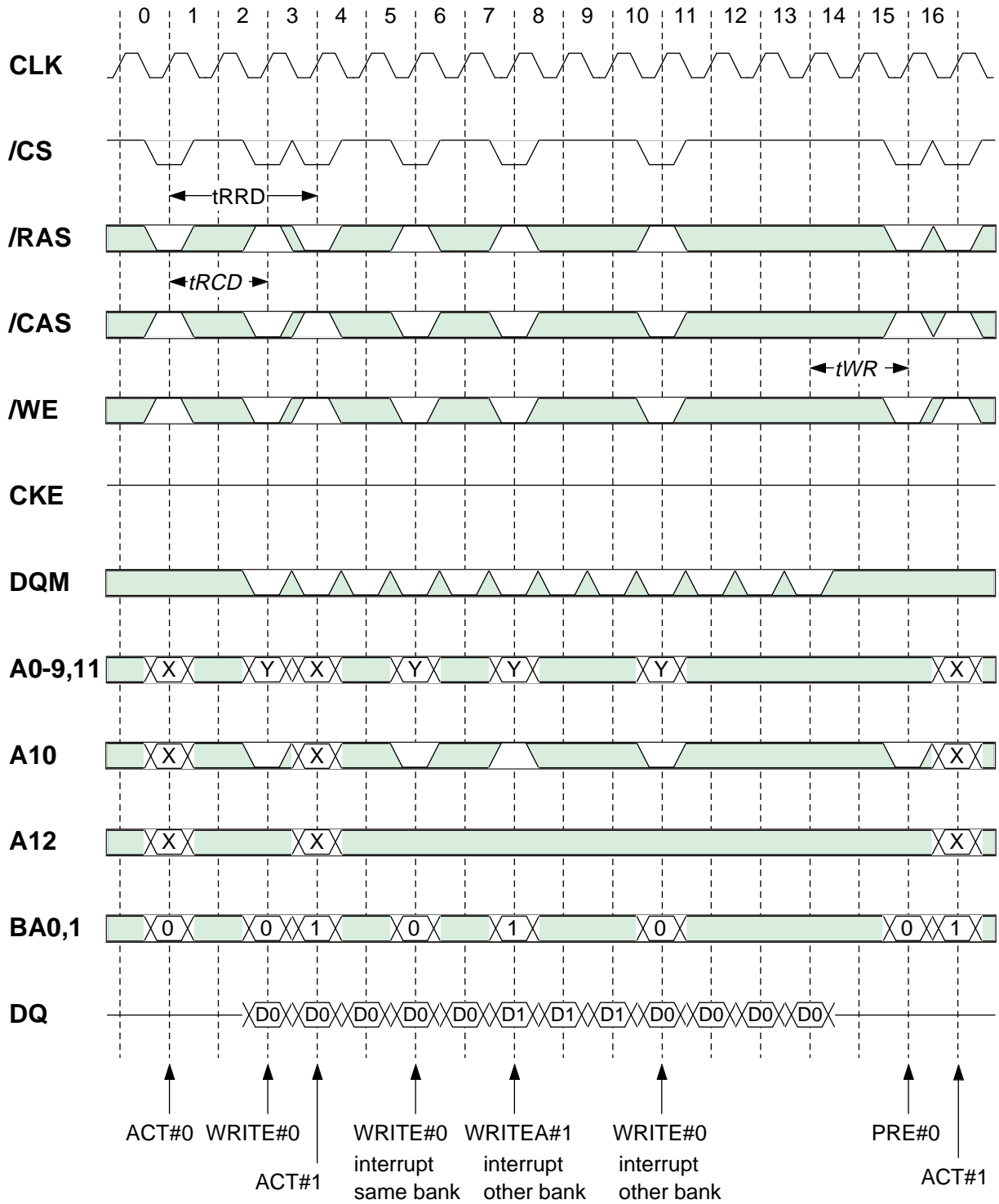

Italic paramater shows minimum case



Z2V56S20BTP (4-BANK x 16,777,216-WORD x 4-BIT)
 Z2V56S30BTP (4-BANK x 8,388,608-WORD x 8-BIT)
 Z2V56S40BTP (4-BANK x 4,194,304-WORD x 16-BIT)

Read Interrupted by Read [CL=2, BL=4]

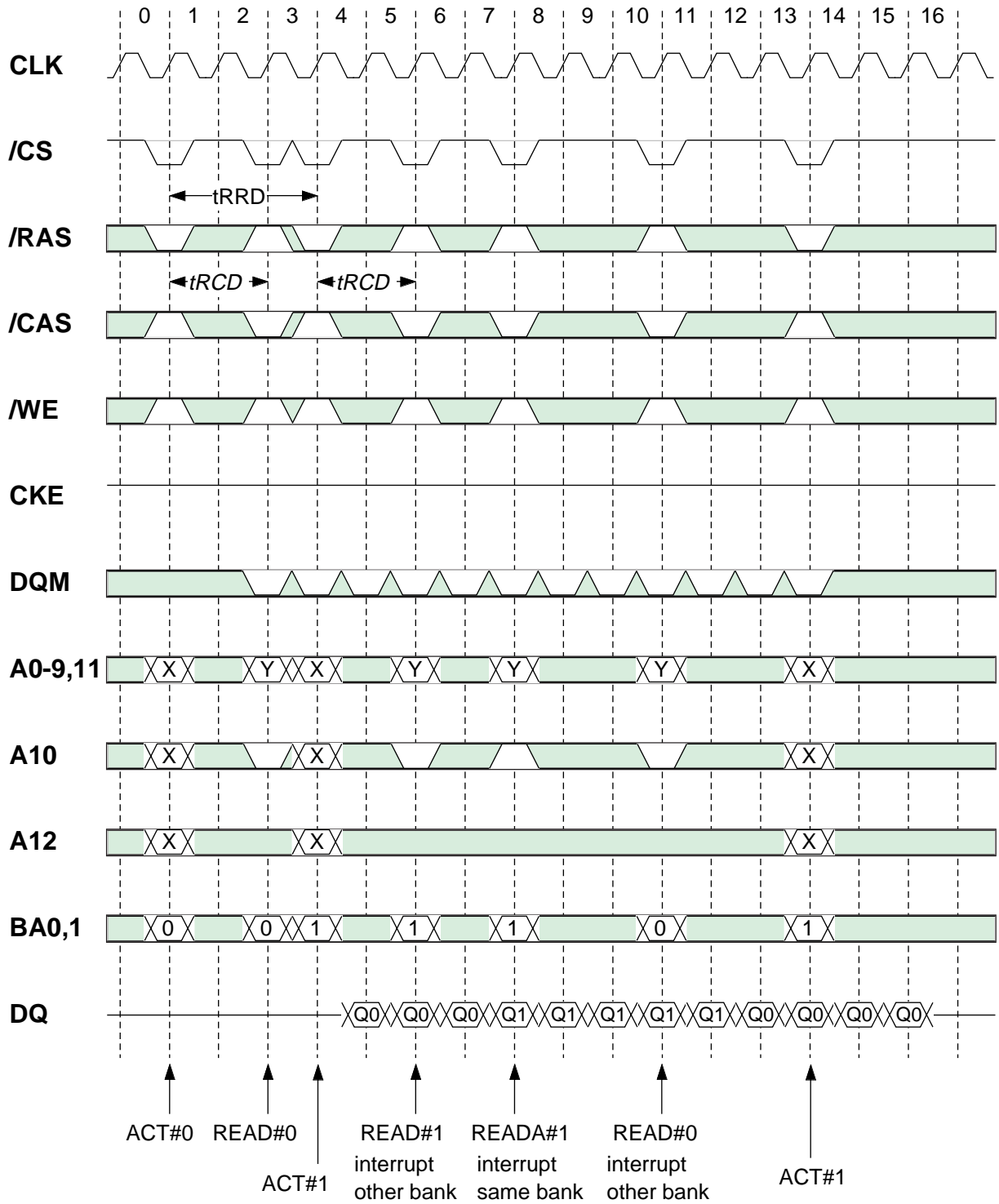

Italic parameter shows minimum case



Z2V56S20BTP (4-BANK x 16,777,216-WORD x 4-BIT)
 Z2V56S30BTP (4-BANK x 8,388,608-WORD x 8-BIT)
 Z2V56S40BTP (4-BANK x 4,194,304-WORD x 16-BIT)

Write Interrupted by Read, Read Interrupted by Write [CL=2, BL=4]

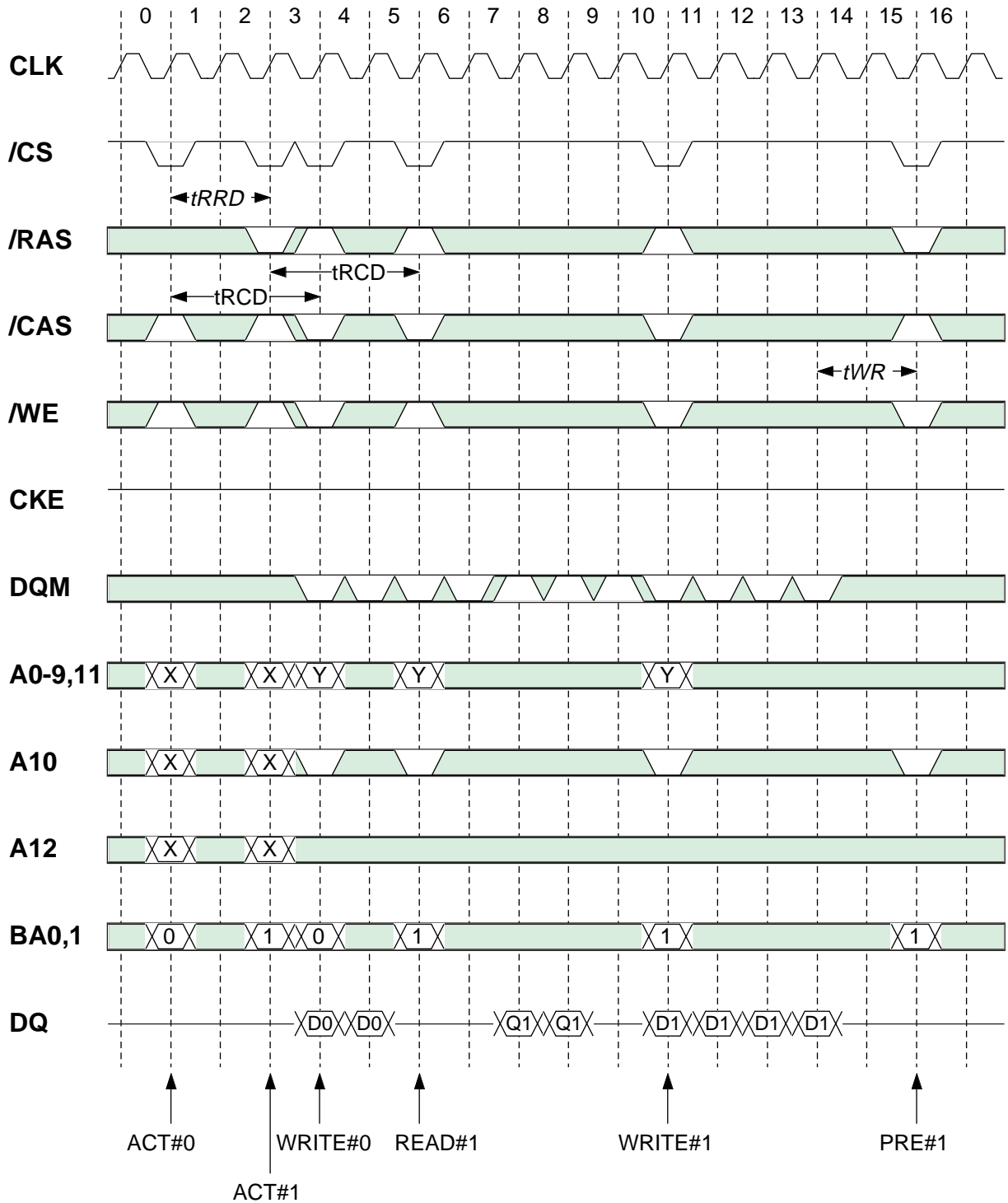

Italic parameter shows minimum case



Z2V56S20BTP (4-BANK x 16,777,216-WORD x 4-BIT)
 Z2V56S30BTP (4-BANK x 8,388,608-WORD x 8-BIT)
 Z2V56S40BTP (4-BANK x 4,194,304-WORD x 16-BIT)

Write / Read Terminated by Precharge [CL=2, BL=4]

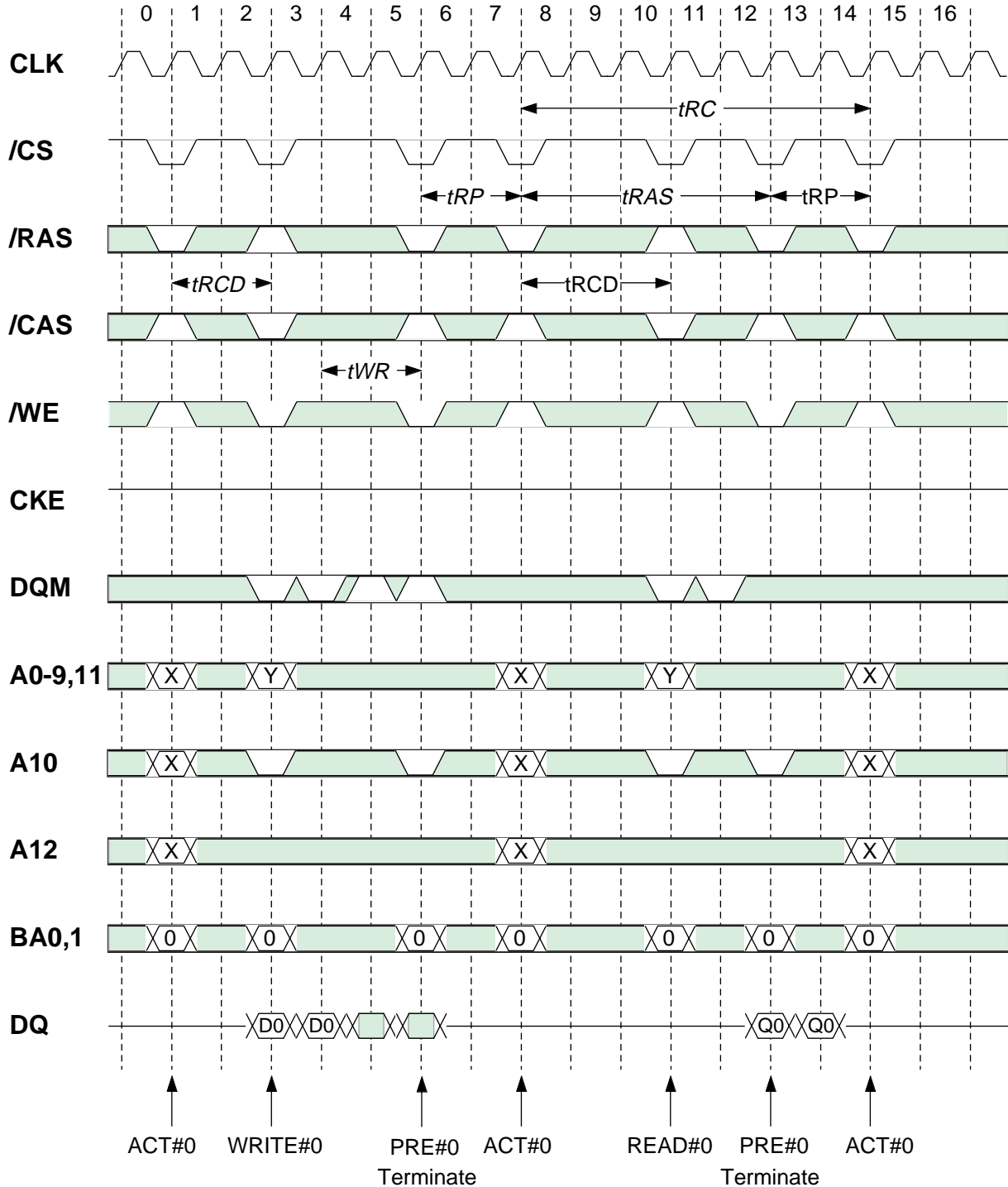

Italic parameter shows minimum case



Z2V56S20BTP (4-BANK x 16,777,216-WORD x 4-BIT)
 Z2V56S30BTP (4-BANK x 8,388,608-WORD x 8-BIT)
 Z2V56S40BTP (4-BANK x 4,194,304-WORD x 16-BIT)

Write / Read Terminated by Burst Terminate [CL=2, BL=4]

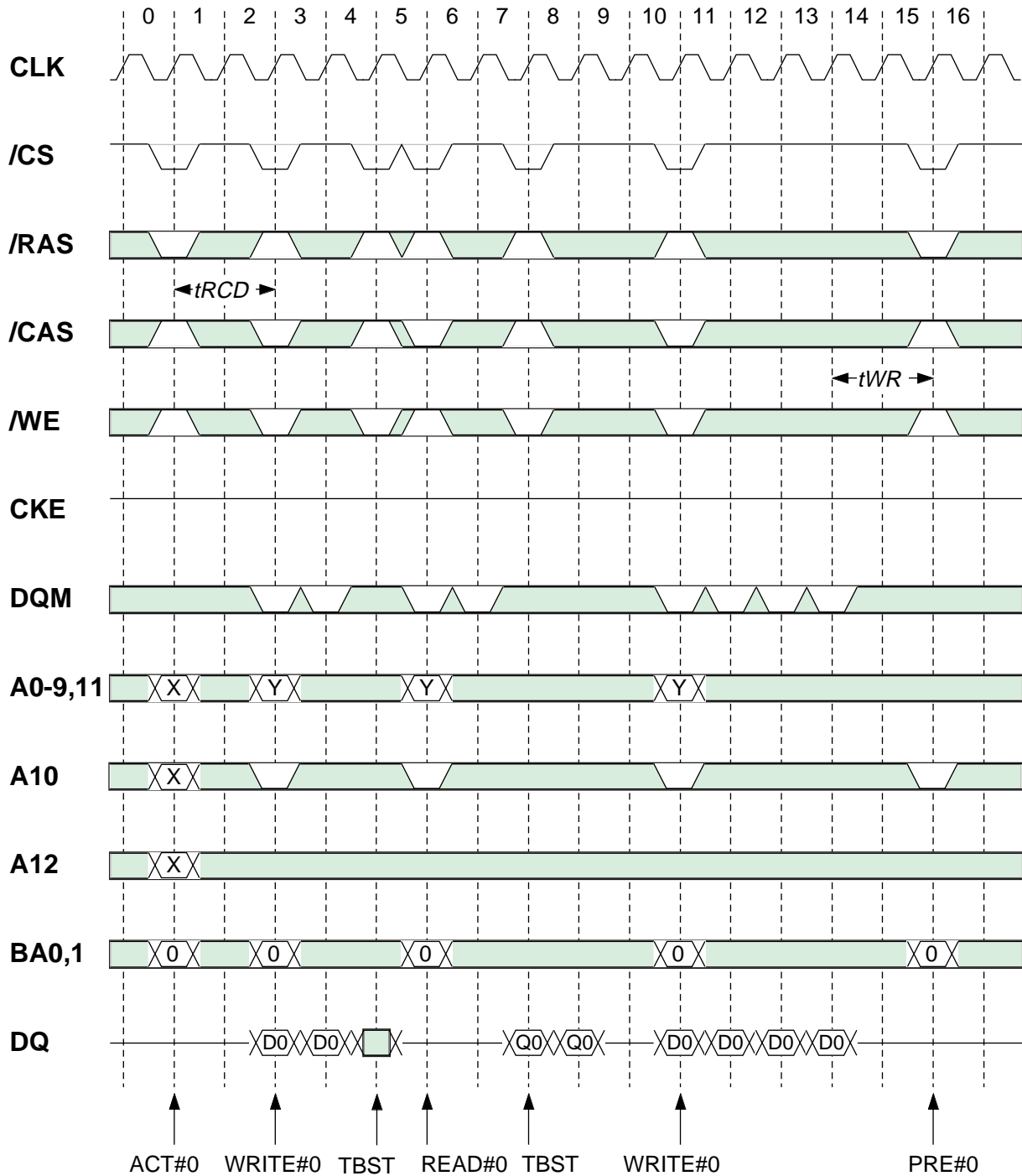

Italic parameter shows minimum case



Z2V56S20BTP (4-BANK x 16,777,216-WORD x 4-BIT)
 Z2V56S30BTP (4-BANK x 8,388,608-WORD x 8-BIT)
 Z2V56S40BTP (4-BANK x 4,194,304-WORD x 16-BIT)

Single Write Burst Read [CL=2, BL=4]

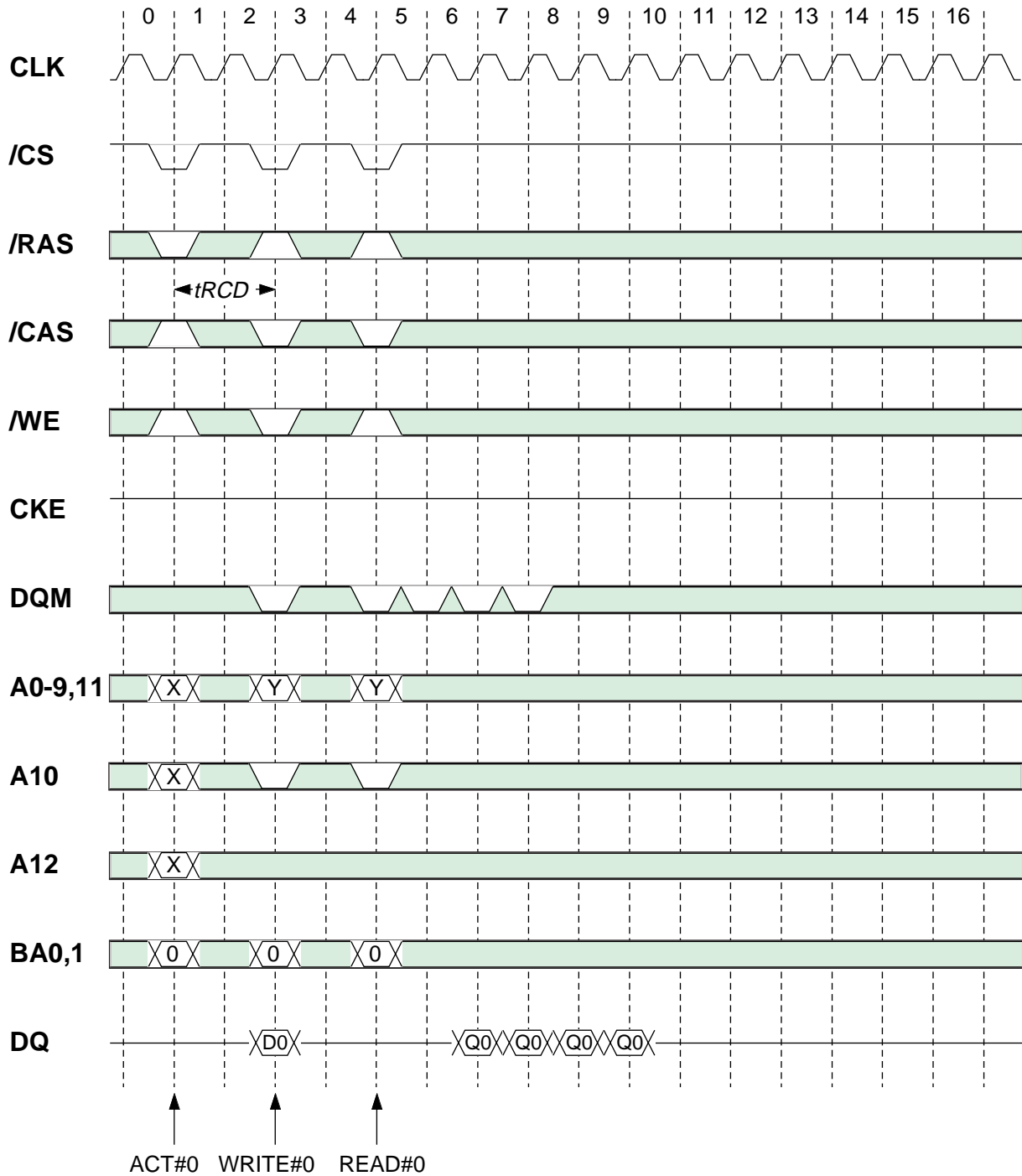

Italic parameter shows minimum case



Z2V56S20BTP (4-BANK x 16,777,216-WORD x 4-BIT)
 Z2V56S30BTP (4-BANK x 8,388,608-WORD x 8-BIT)
 Z2V56S40BTP (4-BANK x 4,194,304-WORD x 16-BIT)

Power-Up Sequence and Intialize

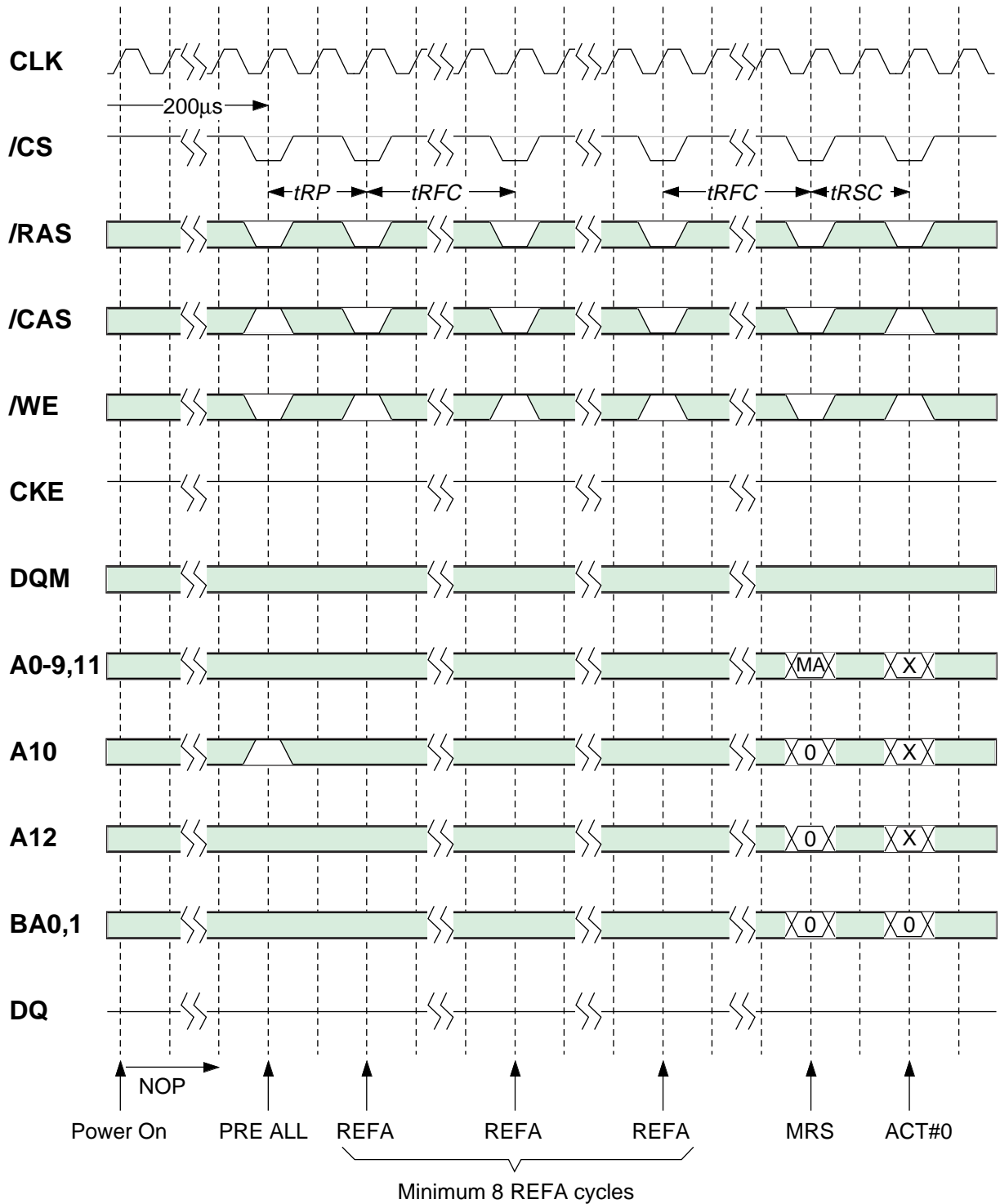

Italic paramater shows minimum case



Z2V56S20BTP (4-BANK x 16,777,216-WORD x 4-BIT)
 Z2V56S30BTP (4-BANK x 8,388,608-WORD x 8-BIT)
 Z2V56S40BTP (4-BANK x 4,194,304-WORD x 16-BIT)

Auto Refresh

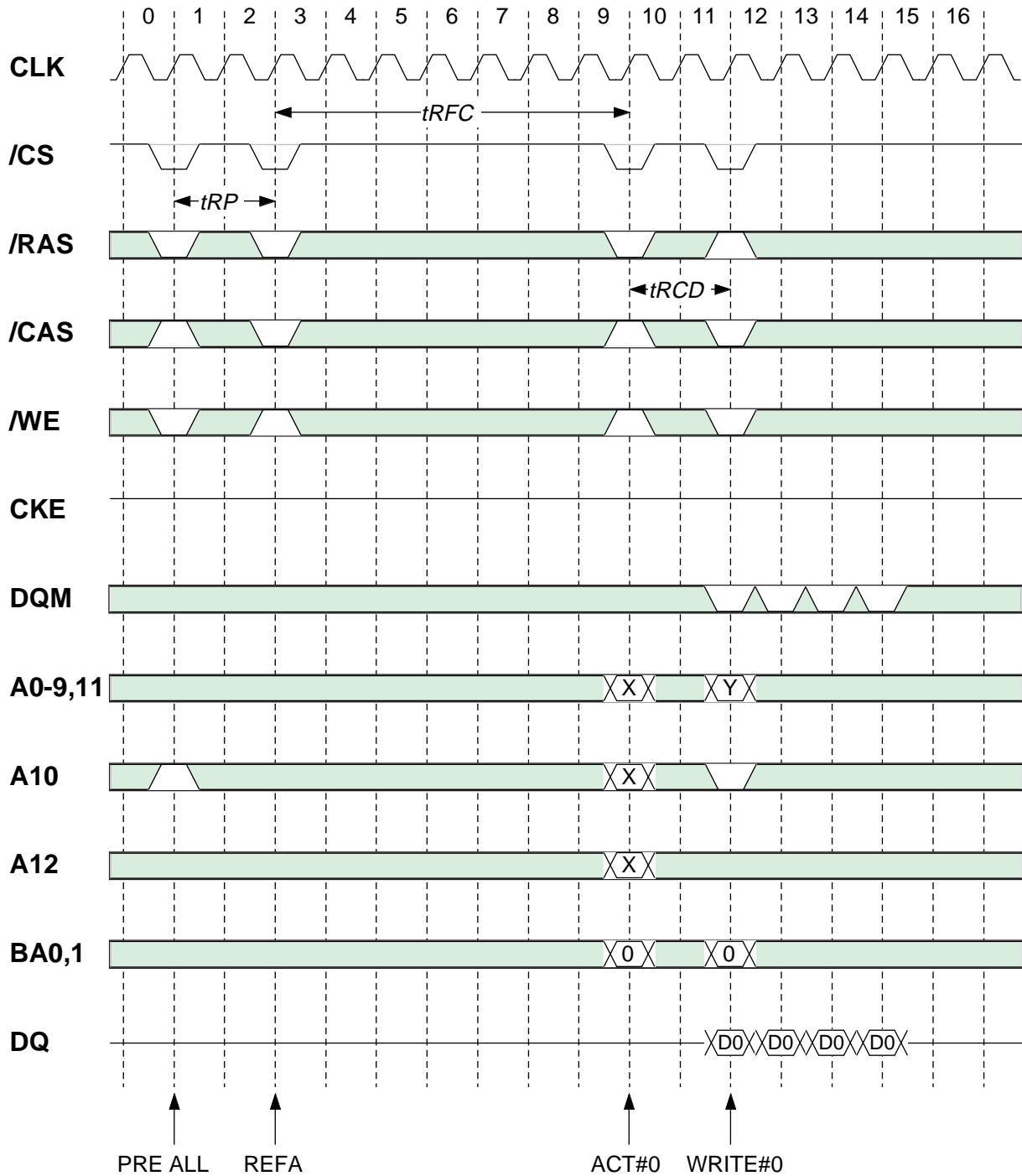

All banks must be idle before REFA is issued.

Italic parameter shows minimum case



Z2V56S20BTP (4-BANK x 16,777,216-WORD x 4-BIT)
 Z2V56S30BTP (4-BANK x 8,388,608-WORD x 8-BIT)
 Z2V56S40BTP (4-BANK x 4,194,304-WORD x 16-BIT)

Self Refresh

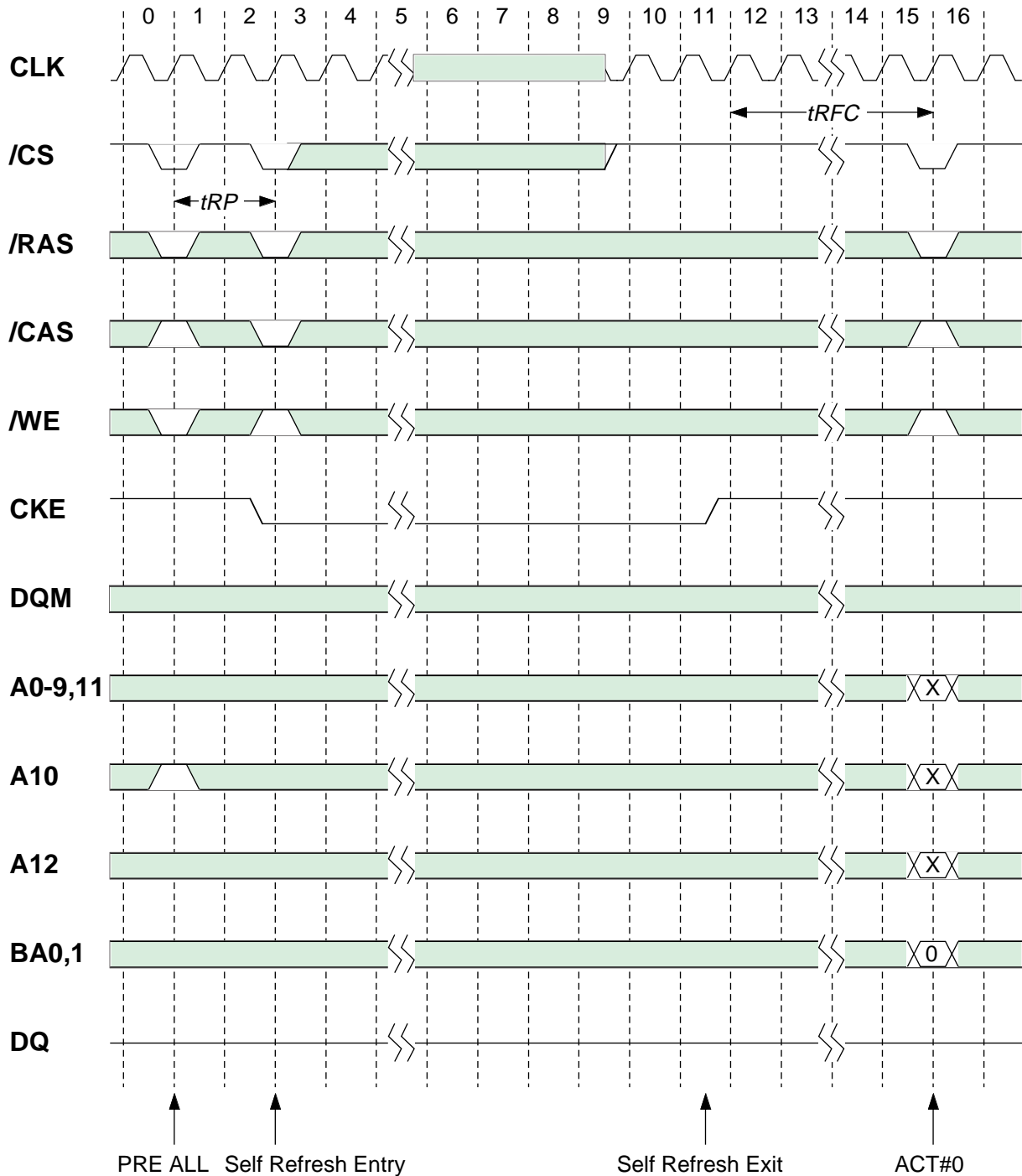

All banks must be idle before REFS is issued.

Italic parameter shows minimum case



Z2V56S20BTP (4-BANK x 16,777,216-WORD x 4-BIT)
 Z2V56S30BTP (4-BANK x 8,388,608-WORD x 8-BIT)
 Z2V56S40BTP (4-BANK x 4,194,304-WORD x 16-BIT)

CLK Suspension [CL=2, BL=4]

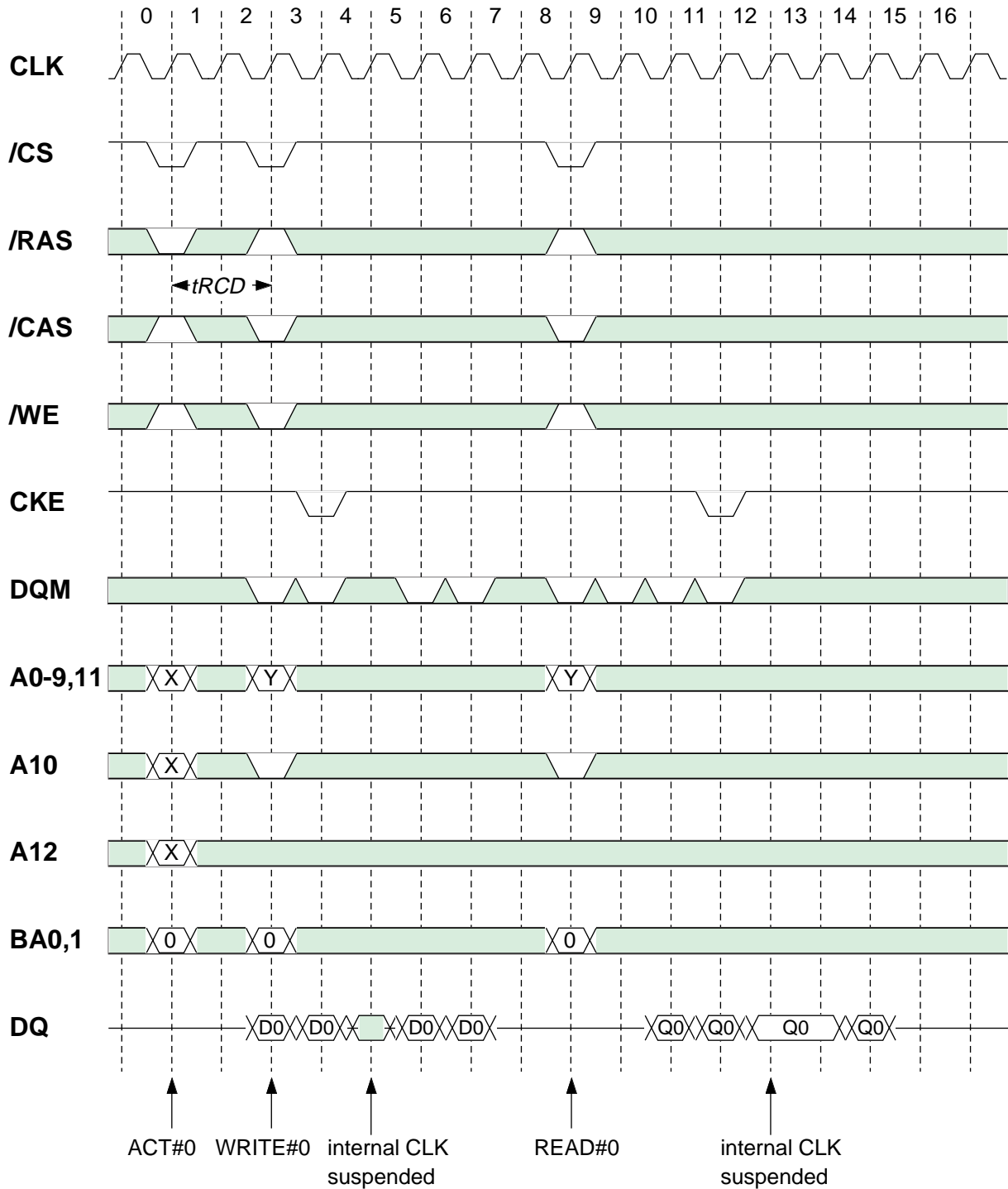

Italic parameter shows minimum case



Z2V56S20BTP (4-BANK x 16,777,216-WORD x 4-BIT)
 Z2V56S30BTP (4-BANK x 8,388,608-WORD x 8-BIT)
 Z2V56S40BTP (4-BANK x 4,194,304-WORD x 16-BIT)

Power Down

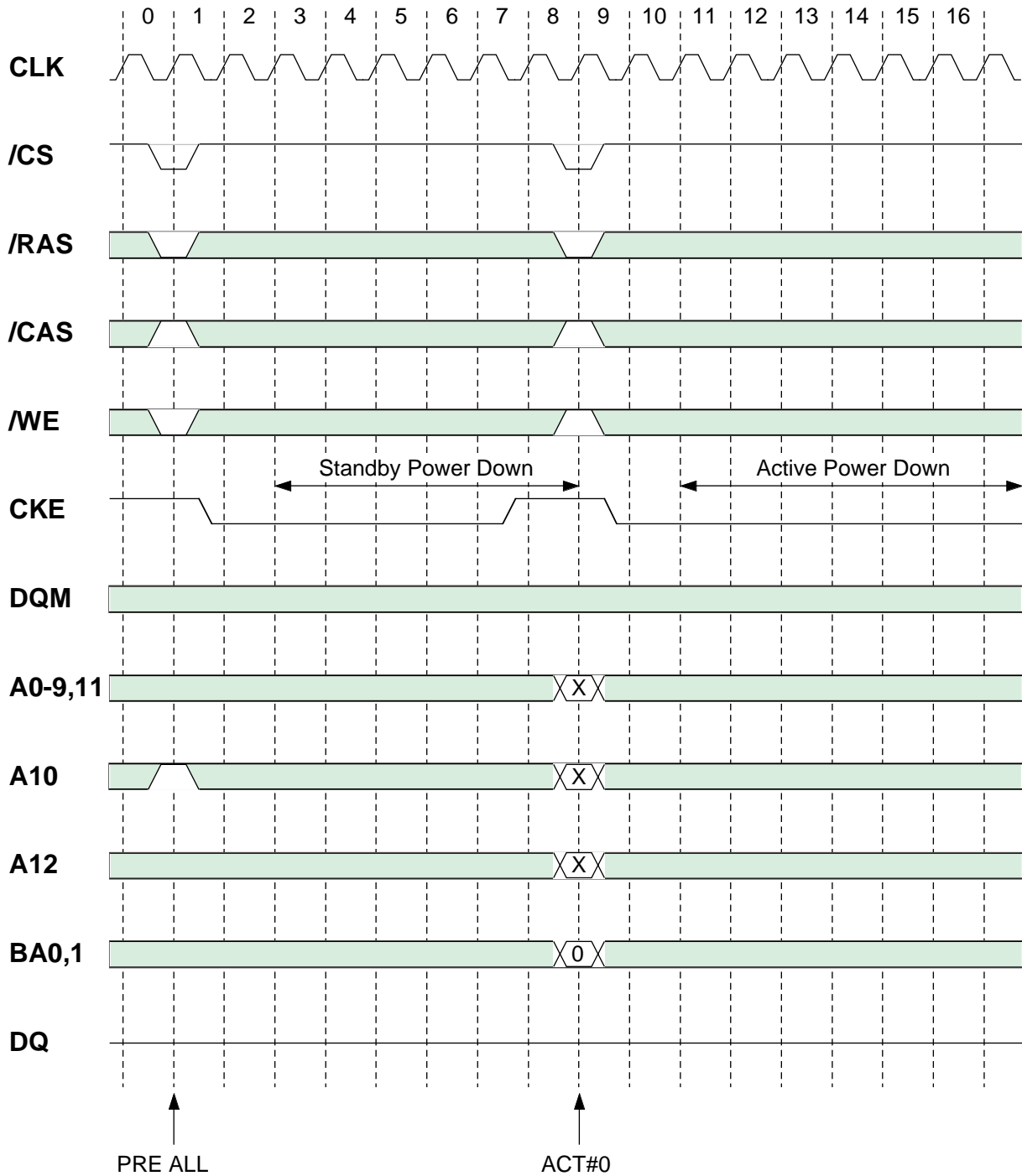

Italic parameter shows minimum case