

Z86C63/64

CMOS Z8[®] 32K ROM MICROCONTROLLER

GENERAL DESCRIPTION

The Z86C63/64 microcontroller introduces a new level of sophistication to single-chip architecture. The Z86C63/64 is a member of the Z8 single-chip microcontroller family with 32 Kbytes of ROM and 256 bytes of RAM.

The Z86C63 is housed in a 40-pin DIP, and a 44-pin PLCC package, and is manufactured in CMOS technology. The ROMless pin option is available on the 44-pin version only. The Z86C64 is housed in a 64-pin DIP, and a 68-pin PLCC. Both versions of the Z86C64 have the ROMless pin option, which allows both external memory and preprogrammed ROM, enabling this Z8 microcontroller to be used in high-volume applications or where code flexibility is required. The Z86C96 ROMless Z8 will support the Z86C63/64.

Zilog's CMOS microcontroller offers fast execution, more efficient use of memory, more sophisticated interrupts, input/output bit manipulation capabilities, and easy hardware/software system expansion along with low cost and low power consumption.

The Z86C63/64 architecture is characterized by Zilog's 8-bit microcontroller core. The device offers a flexible I/O scheme, an efficient register and address space structure, multiplexed capabilities between address/data, I/O, and a number of ancillary features that are useful in many industrial and advanced scientific applications.

For applications which demand powerful I/O capabilities, the Z86C63 fulfills this with 32 pins dedicated to input and output. These lines are grouped into four ports with eight lines each. The Z86C64 has 52 pins for input and output, and these lines are grouped into six, 8-bit ports and one 4-bit port. Each port is configurable under software control to provide timing, status signals, serial or parallel I/O with or without handshake, and an address/data bus for interfacing external memory.

There are three basic address spaces available to support this wide range of configurations: Program Memory, Data Memory, and 236 General-Purpose Registers.

To unburden the program from coping with the real-time problems such as counting/timing and serial data communication, the Z86C63/64 offers two on-chip counter/timers with a large number of user selectable modes, and an asynchronous receiver/transmitter (UART) (see Block Diagrams).

Notes:

All Signals with a preceding front slash, "/", are active Low, e.g., B/W (WORD is active Low); /B/W (BYTE is active Low, only).

Power connections follow conventional descriptions below:

Connection	Circuit	Device
Power Ground	V _{CC} GND	V _{DD} V _{SS}

GENERAL DESCRIPTION

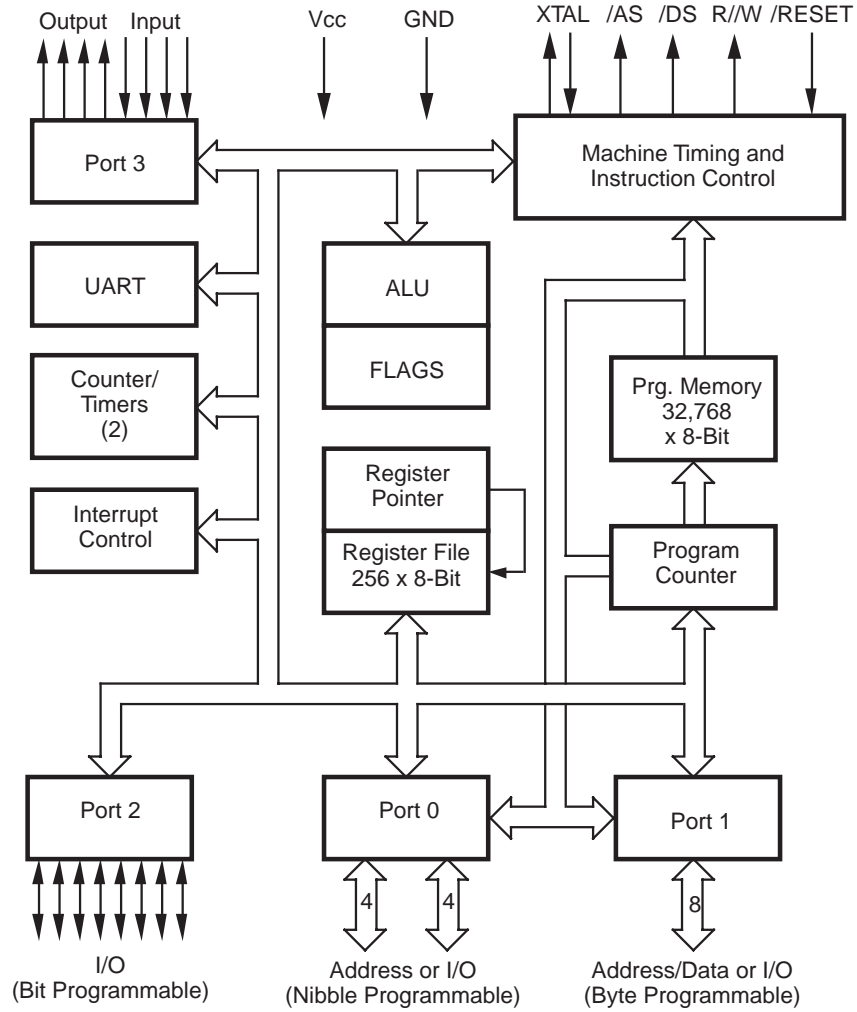

Z86C63 Functional Block Diagram

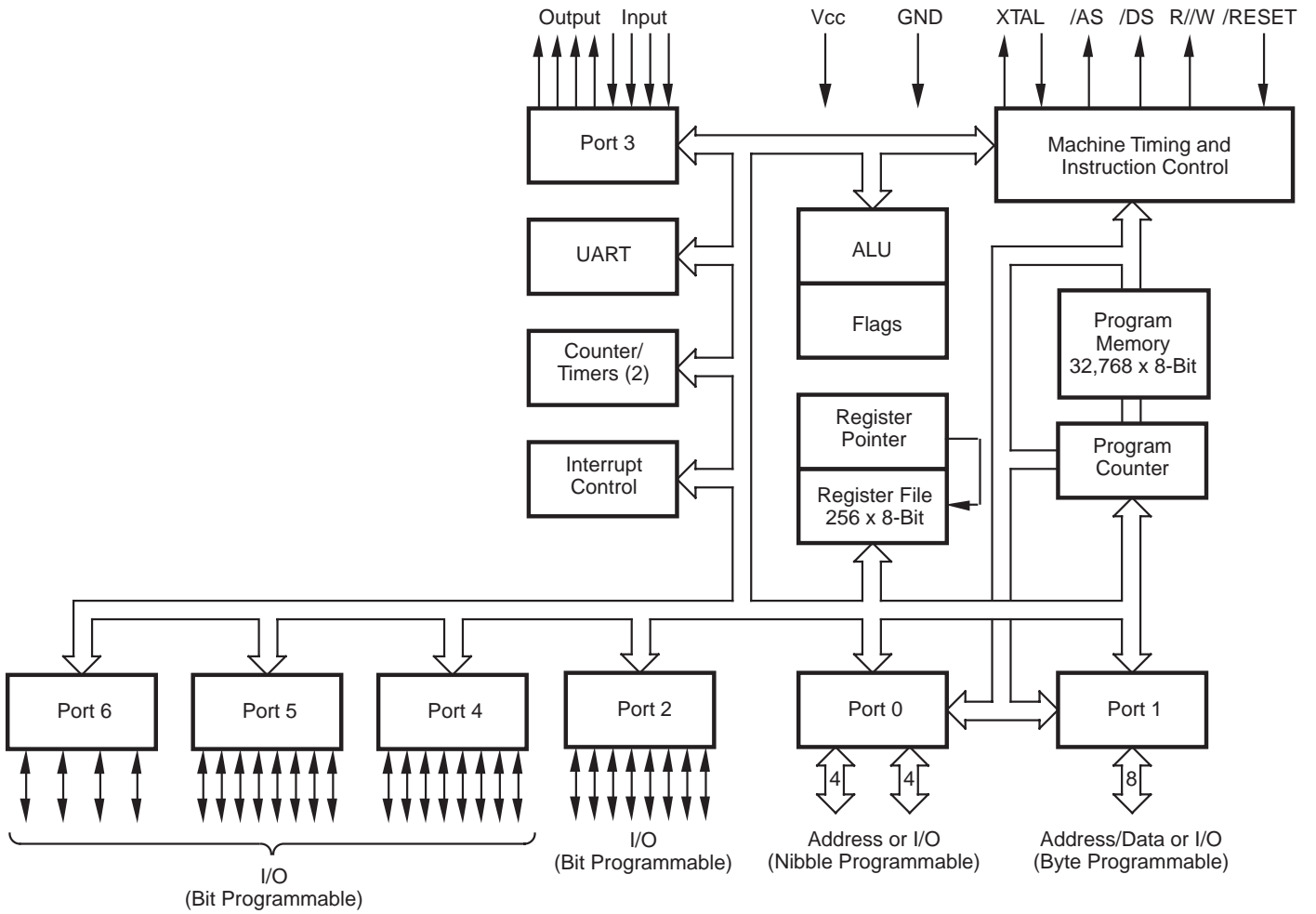

Z86C64 Functional Block Diagram

PIN DESCRIPTION

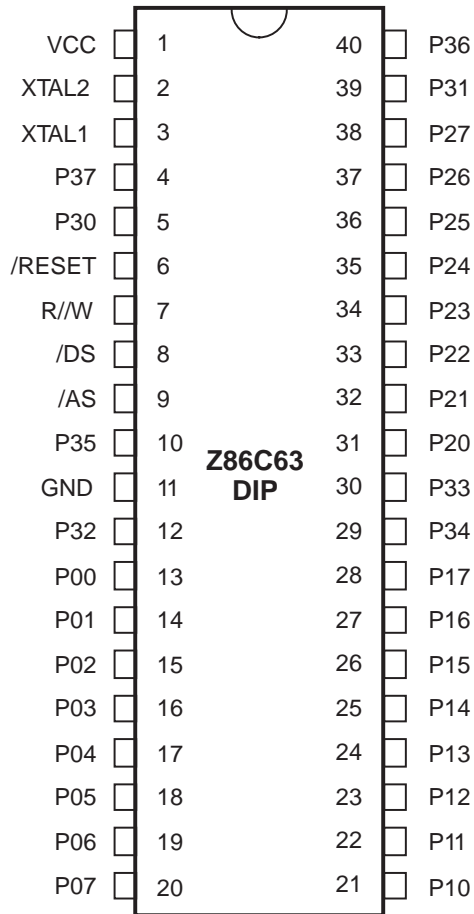

**Z86C63 40-Pin DIP
Pin Assignments**

Z86C63 40-Pin DIP Pin Identification

Pin #	Symbol	Function	Direction
1	V _{CC}	Power Supply	Input
2	XTAL2	Crystal, Oscillator Clock	Output
3	XTAL1	Crystal, Oscillator Clock	Input
4	P37	Port 3, Pin 7	Output
5	P30	Port 3, Pin 0	Input
6	/RESET	Reset	Input
7	R/W	Read/Write	Output
8	/DS	Data Strobe	Output
9	/AS	Address Strobe	Output
10	P35	Port 3, Pin 5	Output
11	GND	Ground	Input
12	P32	Port 3, Pin 2	Input
13-20	P07-P00	Port 0, Pins 0, 1, 2, 3, 4, 5, 6, 7	In/Output
21-28	P17-P10	Port 1, Pins 0, 1, 2, 3, 4, 5, 6, 7	In/Output
29	P34	Port 3, Pin 4	Output
30	P33	Port 3, Pin 3	Input
31-38	P27-P20	Port 2, Pins 0, 1, 2, 3, 4, 5, 6, 7	In/Output
39	P31	Port 3, Pin 1	Input
40	P36	Port 3, Pin 6	Output

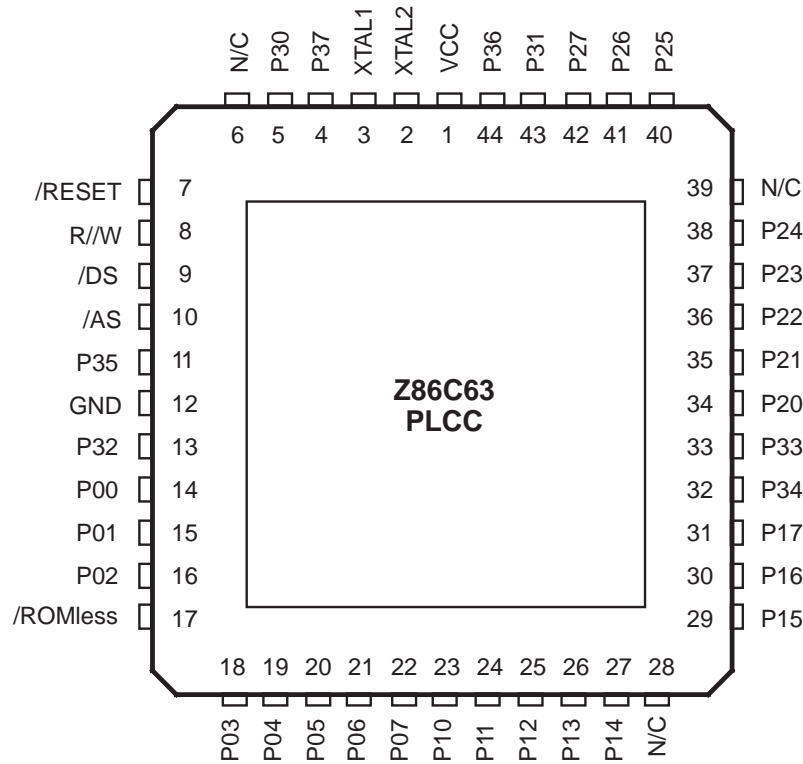

Z86C63 44-Pin PLCC Pin Assignments

Z86C63 44-Pin PLCC Pin Identification

Pin #	Symbol	Function	Direction	Pin #	Symbol	Function	Direction
1	V _{CC}	Power Supply	Input	17	/ROMless	ROM/ROMless control	Input
2	XTAL2	Crystal, Oscillator Clock	Output	18-22	P07-P03	Port 0, Pins 3,4,5,6,7	In/Output
3	XTAL1	Crystal, Oscillator Clock	Input	23-27	P14-P10	Port 1, Pins 0,1,2,3,4	In/Output
4	P37	Port 3, Pin 7	Output	28	N/C	Not Connected	Input
5	P30	Port 3, Pin 0	Input	29-31	P17-P15	Port 1, Pins 5,6,7	In/Output
6	N/C	Not Connected	Input	32	P34	Port 3, Pin 4	Output
7	/RESET	Reset	Input	33	P33	Port 3, Pin 3	Input
8	R/W	Read/Write	Output	34-38	P24-P20	Port 2, Pins 0,1,2,3,4	In/Output
9	/DS	Data Strobe	Output	39	N/C	Not Connected	Input
10	/AS	Address Strobe	Output	40-42	P25-P27	Port 2, Pins 5,6,7	In/Output
11	P35	Port 3, Pin 5	Output	43	P31	Port 3, Pin 1	Input
12	GND	Ground	Input	44	P36	Port 3, Pin 6	Output
13	P32	Port 3, Pin 2	Input				
14-16	P02-P00	Port 0, Pins 0,1,2	In/Output				

PIN DESCRIPTION (Continued)

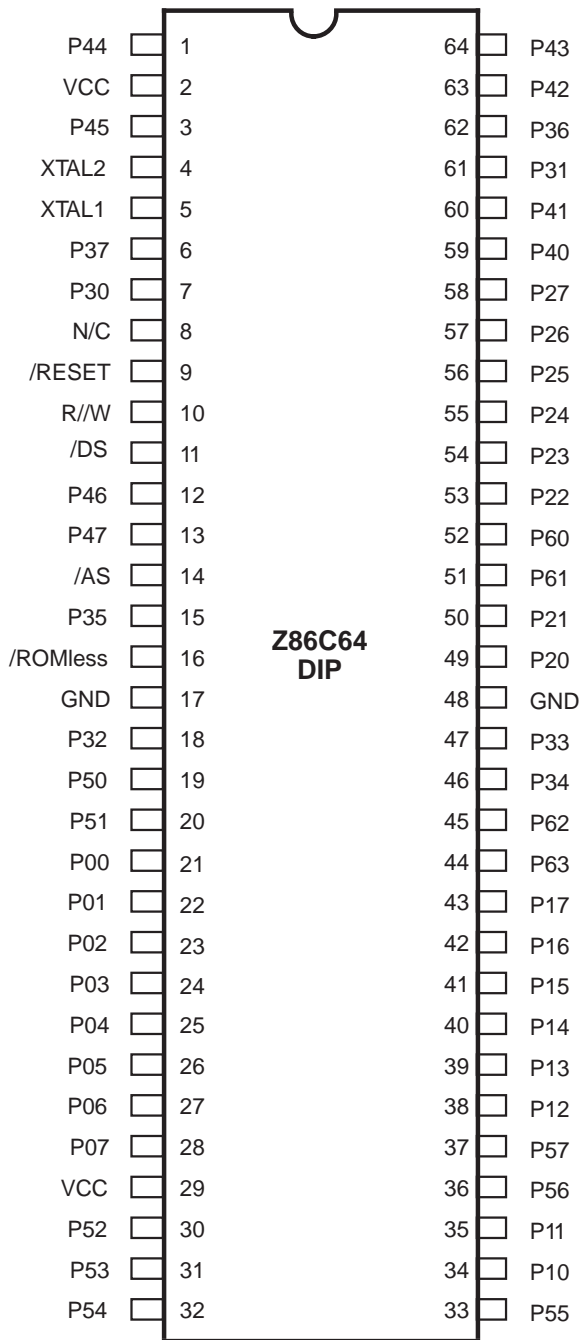

**Z86C64
DIP**

Z86C64 64-Pin DIP Pin Assignments

Z86C64 64-Pin DIP Pin Identification

Pin #	Symbol	Function	Direction
1	P44	Port 4, Pin 4	In/Output
2	V _{CC}	Power Supply	Input
3	P45	Port 4, Pin 5	In/Output
4	XTAL2	Crystal, Oscillator Clock	Output
5	XTAL1	Crystal, Oscillator Clock	Input
6	P37	Port 3, Pin 7	Output
7	P30	Port 3, Pin 0	Input
8	N/C	Not Connected	Input
9	/RESET	Reset	Input
10	R/W	Read/Write	Output
11	/DS	Data Strobe	Output
12-13	P47-P46	Port 4, Pin 6,7	In/Output
14	/AS	Address Strobe	Output
15	P35	Port 3, Pin 5	Output
16	/ROMless	ROM/ROMless control	Input
17	GND	Ground	Input
18	P32	Port 3, Pin 2	Input
19-20	P51-P50	Port 5, Pin 0,1	In/Output
21-28	P07-P00	Port 0, Pins 0,1,2,3,4,5,6,7	In/Output
29	V _{CC}	Power Supply	Input
30-33	P52-P55	Port 5, Pins 2,3,4,5	In/Output
34-35	P11-P10	Port 1, Pins 0,1	In/Output
36-37	P57-P56	Port 5, Pins 6,7	In/Output
38-43	P17-P12	Port 1, Pins 2,3,4,5,6,7	In/Output
44-45	P63-P62	Port 6, Pins 3,2	In/Output
46	P34	Port 3, Pin 4	Output
47	P33	Port 3, Pin 3	Input
48	GND	Ground	Input
49-50	P21-P20	Port 2, Pins 0,1	In/Output
51-52	P61-P60	Port 6, Pins 1,0	In/Output
53-58	P27-P22	Port 2, Pins 2,3,4,5,6,7	In/Output
59-60	P41-P40	Port 4, Pins 0,1	In/Output
61	P31	Port 3, Pin 1	Input
62	P36	Port 3, Pin 6	Output
63	P42	Port 4, Pin 2	In/Output
64	P43	Port 4, Pin 3	In/Output

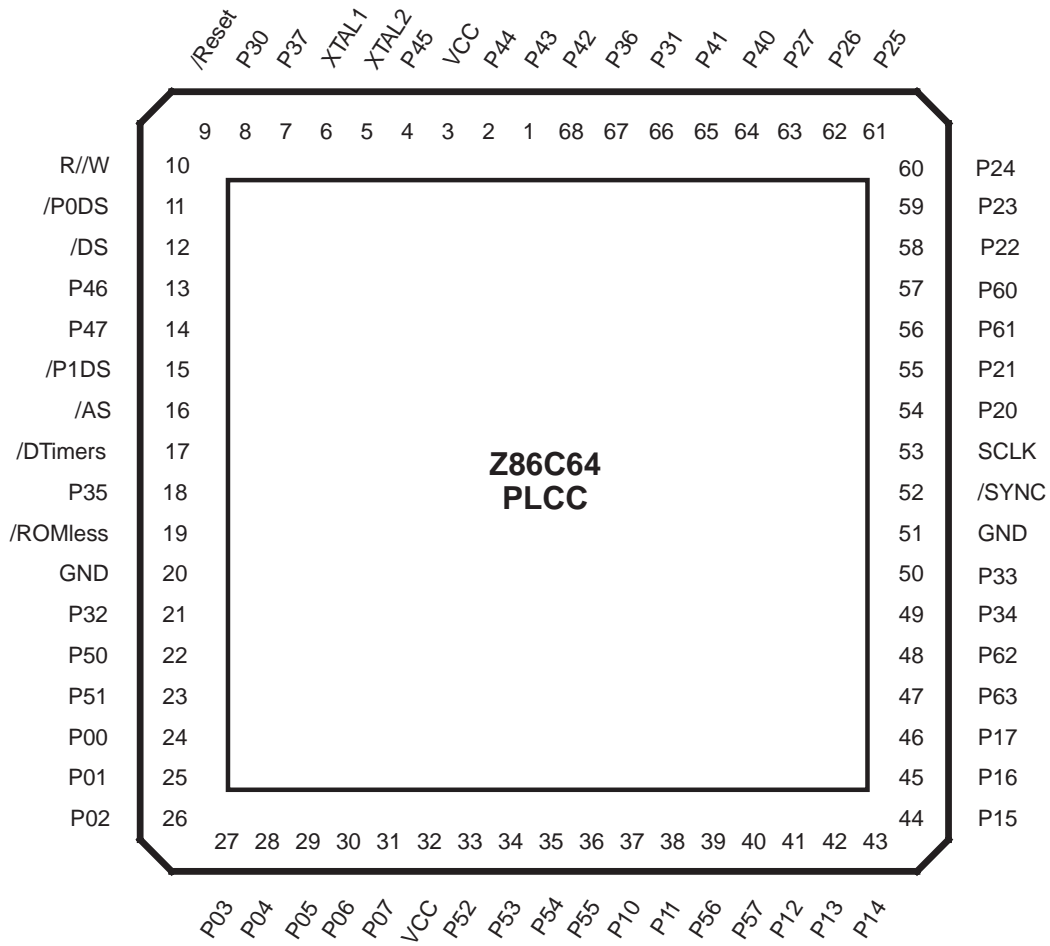

Z86C64 68-Pin PLCC Pin Assignments

PIN DESCRIPTION (Continued)

Z86C64 68-Pin PLCC Pin Identification

Pin #	Symbol	Function	Direction	Pin #	Symbol	Function	Direction
1-2	P44-P43	Port 4, Pins 3,4	In/Output	24-31	P07-P00	Port 0, Pins 0,1,2,3,4,5,6,7	In/Output
3	V _{CC}	Power Supply	Input	32	V _{CC}	Power Supply	Input
4	P45	Port 4, Pin 5	In/Output	33-36	P55-P52	Port 5, Pins 2,3,4,5	In/Output
5	XTAL2	Crystal, Oscillator Clock	Output	37-38	P11-P10	Port 1, Pins 0,1	In/Output
6	XTAL1	Crystal, Oscillator Clock	Input	39-40	P56-P57	Port 5, Pins 6,7	In/Output
7	P37	Port 3, Pin 7	Output	41-46	P17-P12	Port 1, Pins 2,3,4,5,6,7	In/Output
8	P30	Port 3, Pin 0	Input	47-48	P63-P62	Port 6, Pins 3,2	In/Output
9	/RESET	Reset	Input	49	P34	Port 3, Pin 4	Output
10	R/W	Read/Write	Output	50	P33	Port 3, Pin 3	Input
11	/PODS	Port 0 Data Strobe	Output	51	GND	Ground	Input
12	/DS	Data Strobe	Output	52	/SYNC	Synchronization	Output
13-14	P47-P46	Port 4, Pins 6,7	In/Output	53	SCLK	System Clock	Output
15	/P1DS	Port 1, Data Strobe	Output	54-55	P21-P20	Port 2, Pins 0,1	In/Output
16	/AS	Address Strobe	Output	56-57	P60-P61	Port 6, Pins 1,0	In/Output
17	/DTIMER	DTIMER	Input	58-63	P27-P22	Port 2, Pins 2,3,4,5,6,7	In/Output
18	P35	Port 3, Pin 5	Output	64-65	P41-P40	Port 4, Pins 0,1	In/Output
19	/ROMless	ROM/ROMless control	Input	66	P31	Port 3, Pin 1	Input
20	GND	Ground	Input	67	P36	Port 3, Pin 6	Output
21	P32	Port 3, Pin 2	Input	68	P42	Port 4, Pin 2	In/Output
22-23	P51-P50	Port 5, Pins 0,1	In/Output				

ABSOLUTE MAXIMUM RATINGS

Symbol	Description	Min	Max	Units
V_{CC}	Supply Voltage*	-0.3	+7.0	V
T_{STG}	Storage Temp	-65	+150	C
T_A	Oper Ambient Temp	†	†	

Stresses greater than those listed under Absolute Maximum Ratings may cause permanent damage to the device. This is a stress rating only; operation of the device at any condition above those indicated in the operational sections of these specifications is not implied. Exposure to absolute maximum rating conditions for an extended period may affect device reliability.

Notes:

- * Voltages on all pins with respect to GND.
- † See ordering information

STANDARD TEST CONDITIONS

The characteristics listed below apply for standard test conditions as noted. All voltages are referenced to GND. Positive current flows into the referenced pin (Test Load).

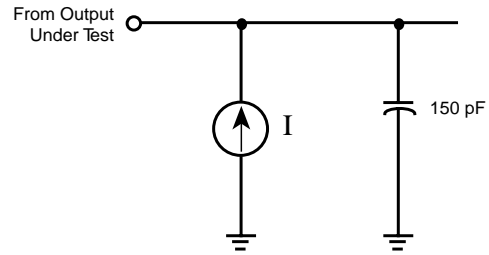

Test Load Diagram

DC ELECTRICAL CHARACTERISTICS

Z86C63

Sym	Parameter	$T_A = 0^\circ\text{C}$ to $+70^\circ\text{C}$		$T_A = -40^\circ\text{C}$ to $+105^\circ\text{C}$		Typical at 25°C	Units	Conditions
		Min	Max	Min	Max			
	Max Input Voltage		7		7		V	[4] $I_{IN} < 250 \mu\text{A}$
V_{CH}	Clock Input High Voltage	$0.85 V_{CC}$	$V_{CC} + 0.3$	$0.85 V_{CC}$	$V_{CC} + 0.3$		V	Driven by External Clock Generator
V_{CL}	Clock Input Low Voltage	$V_{SS} - 0.3$	0.8	$V_{SS} - 0.3$	0.8		V	Driven by External Clock Generator
V_{IH}	Input High Voltage	2	$V_{CC} + 0.3$	2	$V_{CC} + 0.3$		V	
V_{IL}	Input Low Voltage	$V_{SS} - 0.3$	$0.2 V_{CC}$	$V_{SS} - 0.3$	$0.2 V_{CC}$		V	
V_{OH}	Output High Voltage	2.4		2.4			V	$I_{OH} = -2.0 \text{ mA}$
V_{OH}	Output High Voltage		$V_{CC} - 100 \text{ mV}$		$V_{CC} - 100 \text{ mV}$		V	$I_{OH} = -100 \mu\text{A}$
V_{OH}	Output High Voltage (Low EMI)	2.4		2.4			V	$I_{OH} = -0.5 \text{ mA}$
V_{OL}	Output Low Voltage		0.4		0.4		V	$I_{OL} = +5.0 \text{ mA}$ [3]
V_{OL}	Output Low Voltage (Low EMI)		0.4		0.4		V	$I_{OL} = +2.0 \text{ mA}$ [3]
V_{OL}	Output Low Voltage		0.6		0.6		V	$I_{OL} = +4.0 \text{ mA}$ [2]
V_{OL}	Output Low Voltage (Low EMI)		0.6		0.6		V	$I_{OL} = +1.0 \text{ mA}$ [2]
V_{RH}	Reset Input High Voltage	$0.85 V_{CC}$	$V_{CC} + 0.3$	$0.85 V_{CC}$	$V_{CC} + 0.3$		V	
V_{RI}	Reset Input Low Voltage	-0.3	$0.2 V_{CC}$	-0.3	$0.2 V_{CC}$		V	
I_{IL}	Input Leakage	-2	2	-2	2		μA	$V_{IN} = 0 \text{ V}, V_{CC}$
I_{OL}	Output Leakage	-2	2	-2	2		μA	$V_{IN} = 0 \text{ V}, V_{CC}$
I_{IR}	Reset Input Current		-180		-180		μA	$V_{RL} = 0 \text{ V}$
I_{CC}	Supply Current (Standard Mode)		35		35	24	mA	[1] @ 16 MHz
I_{CC}	Supply Current (Standard Mode)		40		40	30	mA	[1] @ 20 MHz
I_{CC}	Supply Current (Low EMI)		6.0			4.0	mA	@ 4 MHz
I_{CC1}	Standby Current (Standard Mode)		15		15	4.5	mA	[1] HALT Mode $V_{IN} = 0 \text{ V}, V_{CC}$ @ 16 MHz
I_{CC1}	Standby Current (Low EMI)		1.6			0.8	mA	@ 4 MHz
I_{CC2}	Standby Current		10		20	5	μA	[1] STOP Mode $V_{IN} = 0 \text{ V}, V_{CC}$
I_{ALL}	Auto Latch Low Current	-14	14	-20	20	5	μA	

Notes:

- [1] All inputs driven to either 0V or V_{CC} , outputs floating.
 [2] $V_{CC} = 3.0\text{V}$ to 3.6V
 [3] $V_{CC} = 4.5\text{V}$ to 5.5V
 [4] /Reset pin must be a maximum of $V_{CC} + 0.3\text{V}$.

AC CHARACTERISTICS

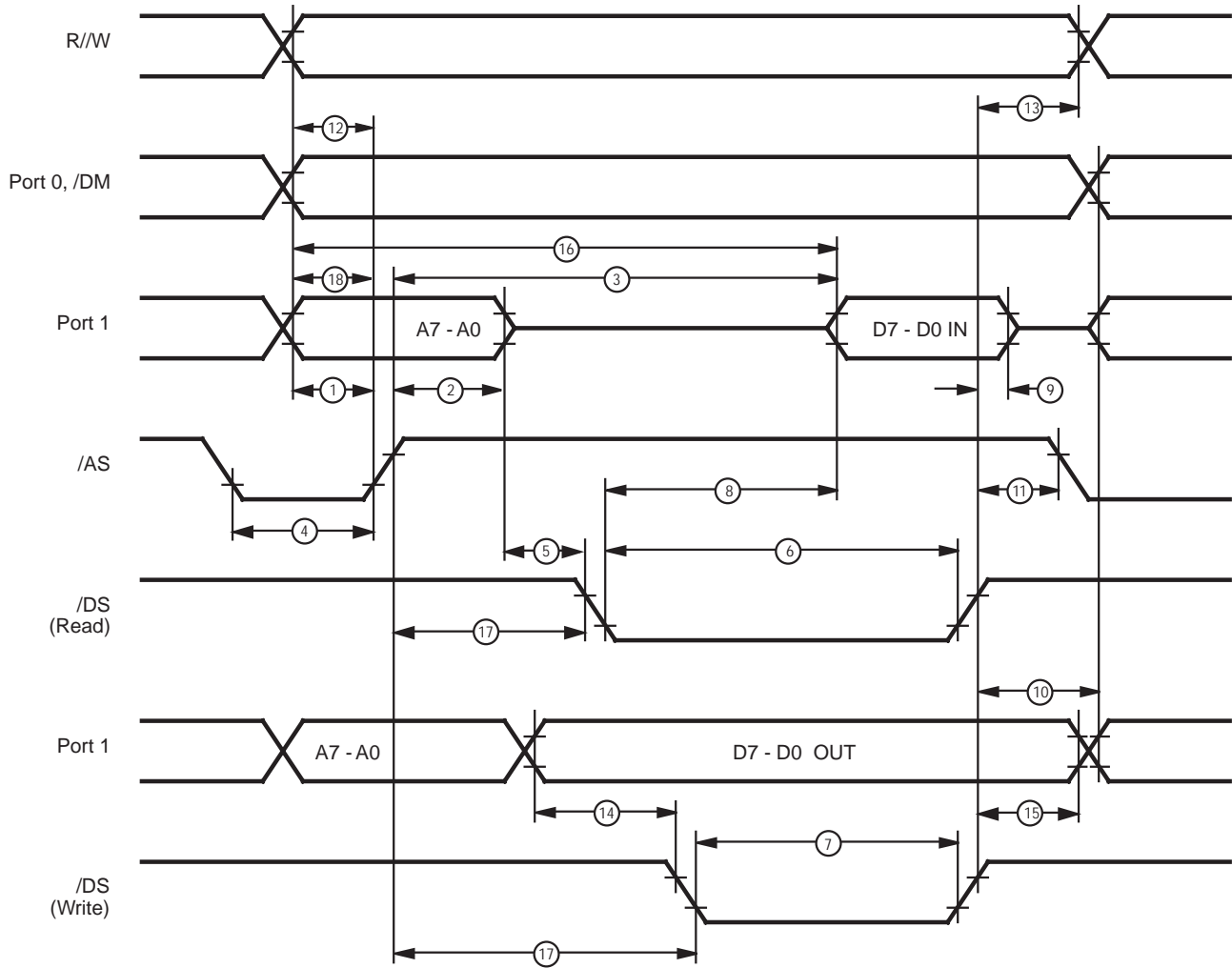

External I/O or Memory Read/Write

AC CHARACTERISTICS

External I/O or Memory Read and Write Timing
Z86C63/64 (16 MHz—Standard Mode Only[4])

No	Symbol	Parameter	$T_A = 0^\circ\text{C}$ to $+70^\circ\text{C}$ 16 MHz		$T_A = -40^\circ\text{C}$ to $+105^\circ\text{C}$ 16 MHz		Units	Notes
			Min	Max	Min	Max		
1	TdA(AS)	Address Valid to /AS rise Delay	25		25		ns	[2,3]
2	TdAS(A)	/AS rise to Address Float Delay	35		35		ns	[2,3]
3	TdAS(DR)	/AS rise to Read Data Req'd Valid		150		150	ns	[1,2,3]
4	TwAS	/AS Low Width	40		40		ns	[2,3]
5	TdAZ(DS)	Address Float to /DS fall	0		0		ns	
6	TwDSR	/DS (Read) Low Width		135		135	ns	[1,2,3]
7	TwDSW	/DS (Write) Low Width	80		80		ns	[1,2,3]
8	TdDSR(DR)	/DS fall to Read Data Req'd Valid	75		75		ns	[1,2,3]
9	ThDR(DS)	Read Data to /DS rise Hold Time	0		0		ns	[2,3]
10	TdDS(A)	/DS rise to Address Active Delay	50		50		ns	[2,3]
11	TdDS(AS)	/DS rise to /AS fall Delay	35		35		ns	[2,3]
12	TdR/W(AS)	R/W Valid to /AS rise Delay	25		25		ns	[2,3]
13	TdDS(R/W)	/DS rise to R/W Not Valid	35		35		ns	[2,3]
14	TdDW(DSW)	Write Data Valid to /DS fall (Write) Delay	25		25		ns	[2,3]
15	TdDS(DW)	/DS rise to Write Data Not Valid Delay	35		35		ns	[2,3]
16	TdA(DR)	Address Valid to Read Data Req'd Valid		210		210	ns	[1,2,3]
17	TdAS(DS)	/AS rise to /DS fall Delay	45		45		ns	[2,3]
18	TdDM(AS)	/DM Valid to /AS rise Delay	25		25		ns	[2,3]

Notes:

- [1] When using extended memory timing add 2 TpC.
- [2] Timing numbers given are for minimum TpC.
- [3] See clock cycle dependent characteristics table.
- [4] Low EMI is not selected.

Standard Test Load

All timing references use 2.0 V for a logic 1 and 0.8 V for a logic 0.

Clock Dependent Formulas

Number	Symbol	Equation
1	TdA(AS)	$0.40 \text{ TpC} + 0.32$
2	TdAS(A)	$0.59 \text{ TpC} - 3.25$
3	TdAS(DR)	$2.83 \text{ TpC} + 6.14$
4	TwAS	$0.66 \text{ TpC} - 1.65$
6	TwDSR	$2.33 \text{ TpC} - 10.56$
7	TwDSW	$1.27 \text{ TpC} + 1.67$
8	TdDSR(DR)	$1.97 \text{ TpC} - 42.5$
10	TdDS(A)	0.8 TpC
11	TdDS(AS)	$0.59 \text{ TpC} - 3.14$
12	TdR/W(AS)	0.4 TpC
13	TdDS(R/W)	$0.8 \text{ TpC} - 15$
14	TdDW(DSW)	0.4 TpC
15	TdDS(DW)	$0.88 \text{ TpC} - 19$
16	TdA(DR)	$4 \text{ TpC} - 20$
17	TdAS(DS)	$0.91 \text{ TpC} - 10.7$
18	TdDM(AS)	$0.9 \text{ TpC} - 26.3$

AC CHARACTERISTICS

External I/O or Memory Read and Write Timing
Z86C63/64 (20 MHz—Standard Mode Only[4])

No	Symbol	Parameter	T _A = 0°C to +70°C 20 MHz		T _A = -40°C to +105°C 20 MHz		Units	Notes
			Min	Max	Min	Max		
1	TdA(AS)	Address Valid to /AS rise Delay	15		25		ns	[2,3]
2	TdAS(A)	/AS rise to Address Float Delay	25		35		ns	[2,3]
3	TdAS(DR)	/AS rise to Read Data Req'd Valid		120		120	ns	[1,2,3]
4	TwAS	/AS Low Width	30		30		ns	[2,3]
5	TdAZ(DS)	Address Float to /DS fall	0		0		ns	
6	TwDSR	/DS (Read) Low Width		105		105	ns	[1,2,3]
7	TwDSW	/DS (Write) Low Width	65		65		ns	[1,2,3]
8	TdDSR(DR)	/DS fall to Read Data Req'd Valid	55		55		ns	[1,2,3]
9	ThDR(DS)	Read Data to /DS rise Hold Time	0		0		ns	[2,3]
10	TdDS(A)	/DS rise to Address Active Delay	40		40		ns	[2,3]
11	TdDS(AS)	/DS rise to /AS fall Delay	25		25		ns	[2,3]
12	TdR/W(AS)	R/W Valid to /AS rise Delay	20		20		ns	[2,3]
13	TdDS(R/W)	/DS rise to R/W Not Valid	25		25		ns	[2,3]
14	TdDW(DSW)	Write Data Valid to /DS fall (Write) Delay	20		20		ns	[2,3]
15	TdDS(DW)	/DS rise to Write Data Not Valid Delay	25		25		ns	[2,3]
16	TdA(DR)	Address Valid to Read Data Req'd Valid		150		150	ns	[1,2,3]
17	TdAS(DS)	/AS rise to /DS fall Delay	35		35		ns	[2,3]
18	TdDM(AS)	/DM Valid to /AS rise Delay	15		15		ns	[2,3]

Notes:

- [1] When using extended memory timing add 2 TpC.
- [2] Timing numbers given are for minimum TpC.
- [3] See clock cycle dependent characteristics table.
- [4] Low EMI is not selected.

Standard Test Load

All timing references use 2.0 V for a logic 1 and 0.8 V for a logic 0.

AC CHARACTERISTICS

Additional Timing Diagram

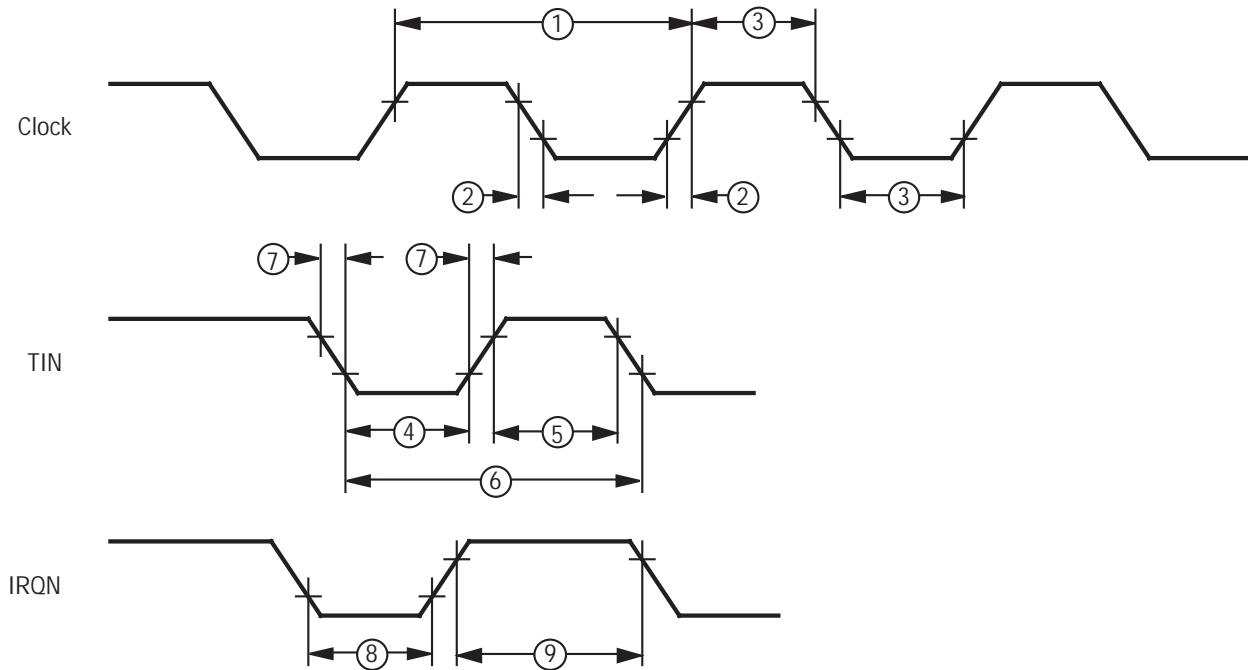

Additional Timing

AC CHARACTERISTICS

Additional Timing Table
Z86C63 (Standard Mode Only)

No	Symbol	Parameter	$T_A = 0^\circ\text{C}$ to $+70^\circ\text{C}$ 20/16 MHz		$T_A = -40^\circ\text{C}$ to $+105^\circ\text{C}$ 20/16 MHz		Units	Notes
			Min	Max	Min	Max		
1	TpC	Input Clock Period	50/62.5	1000	50/62.5	1000	ns	[1]
2	TrC,TfC	Clock Input Rise & Fall Times		10		10	ns	[1]
3	TwC	Input Clock Width	25/31		25/31		ns	[1]
4	TwTinL	Timer Input Low Width	75		75		ns	[2]
5	TwTinH	Timer Input High Width	5 TpC		5 TpC		ns	[2]
6	TpTin	Timer Input Period	8 TpC		8 TpC		ns	[2]
7	TrTin,TfTin	Timer Input Rise and Fall Times	100		100		ns	[2]
8a	TwIL	Interrupt Request Input Low Times	70		50		ns	[2,4]
8b	TwIL	Interrupt Request Input Low Times	5 TpC		5 TpC		ns	[2,5]
9	TwIH	Interrupt Request Input High Times	5 TpC		5 TpC		ns	[2,3]

Notes:

- [1] Clock timing references use $0.85V_{CC}$ for a logic 1 and $0.8V$ for a logic 0.
- [2] Timing references use $2.0V$ for a logic 1 and $0.8V$ for a logic 0.
- [3] Interrupt references request through Port 3.
- [4] Interrupt request through Port 3 (P33-P31).
- [5] Interrupt request through Port 30.

AC CHARACTERISTICS

Additional Timing Table

Z86C63 (Low EMI Mode Only)

No	Symbol	Parameter	$T_A = 0^\circ\text{C}$ to $+70^\circ\text{C}$ 4 MHz		$T_A = -40^\circ\text{C}$ to $+105^\circ\text{C}$ 4 MHz		Units	Notes
			Min	Max	Min	Max		
1	TpC	Input Clock Period	250	DC	250	DC	ns	[1]
2	TrC, Tfc	Clock Input Rise & Fall Times		10		10	ns	[1]
3	TwC	Input Clock Width	125		125		ns	[1]
4	TwTinL	Timer Input Low Width	75		75		ns	[2]
5	TwTinH	Timer Input High Width	3 TpC		3 TpC		ns	[2]
6	TpTin	Timer Input Period	4 TpC		4 TpC		ns	[2]
7	TrTin, Tftin	Timer Input Rise and Fall Times	100		100		ns	[2]
8a	TwIL	Interrupt Request Input Low Times	70		50		ns	[2,4]
8b	TwIL	Interrupt Request Input Low Times	3 TpC		3 TpC		ns	[2,5]
9	TwIH	Interrupt Request Input High Times	3 TpC		3 TpC		ns	[2,3]

Notes:

- [1] Clock timing references use $0.85V_{CC}$ for a logic 1 and 0.8V for a logic 0.
- [2] Timing references use 2.0V for a logic 1 and 0.8V for a logic 0.
- [3] Interrupt references request through Port 3.
- [4] Interrupt request through Port 3 (P33-P31).
- [5] Interrupt request through Port 30.

AC CHARACTERISTICS

Handshake Timing Diagrams

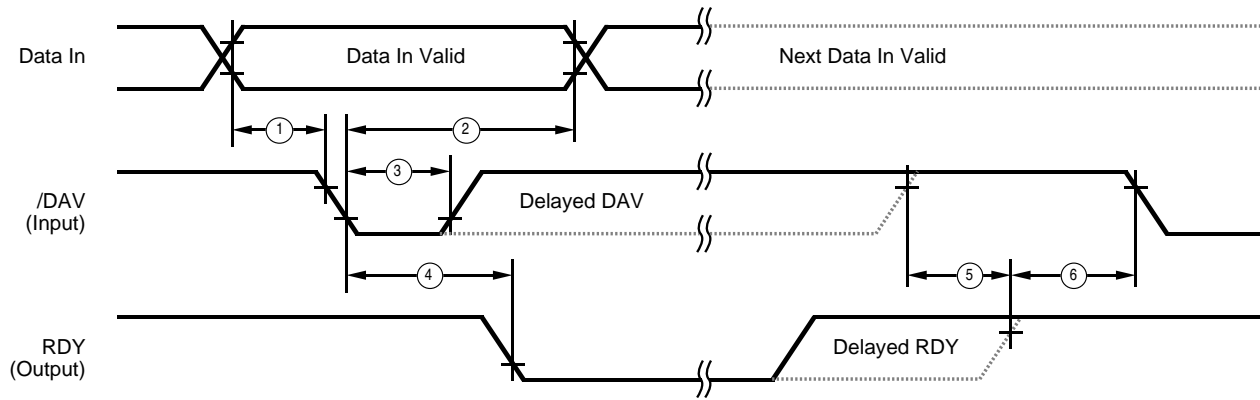

Input Handshake Timing

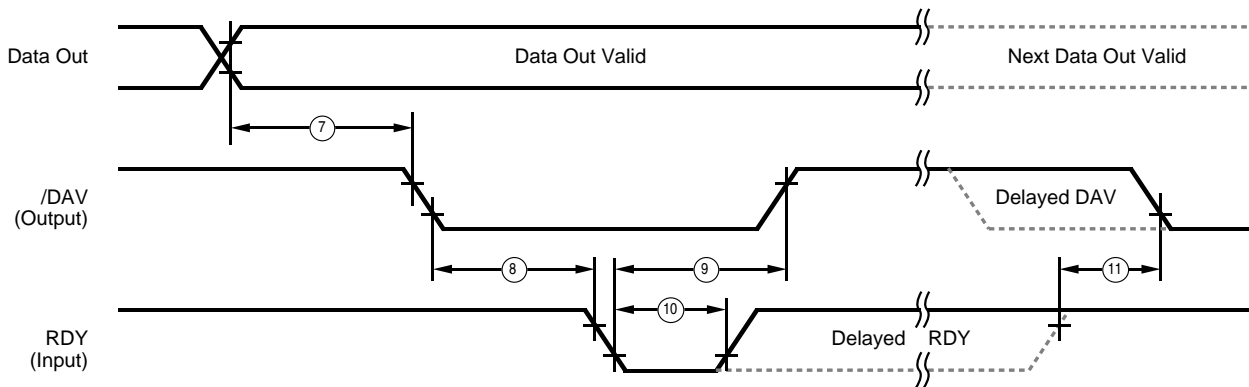

Output Handshake Timing

AC ELECTRICAL CHARACTERISTICS

Handshake Timing Table
Z86C63

No	Symbol	Parameter	$T_A = 0^\circ\text{C to } +70^\circ\text{C}$		$T_A = -40^\circ\text{C to } +105^\circ\text{C}$		Data Direction
			20/16 MHz Min	20/16 MHz Max	20/16 MHz Min	20/16 MHz Max	
1	TsDI(DAV)	Data In Setup Time	0		0		IN
2	ThDI(DAV)	Data In Hold Time	145		145		IN
3	TwDAV	Data Available Width	110		110		IN
4	TdDAVI(RDY)	DAV Fall to RDY Fall Delay	115		115		IN
5	TdDAVId(RDY)	DAV Rise to RDY Rise Delay	115		115		IN
6	TdRDY0(DAV)	RDY Rise to DAV Fall Delay	0		0		IN
7	TdDO(DAV)	Data Out to DAV Fall Delay	TpC		TpC		OUT
8	TdDAV0(RDY)	DAV Fall to RDY Fall Delay	0		0		OUT
9	TdRDY0(DAV)	RDY Fall to DAV Rise Delay	115		115		OUT
10	TwRDY	RDY Width	110		110		OUT
11	TdRDY0d(DAV)	RDY Rise to DAV Fall Delay	115		115		OUT

© 1993, 1994, 1995, 1996, 1997 by Zilog, Inc. All rights reserved. No part of this document may be copied or reproduced in any form or by any means without the prior written consent of Zilog, Inc. The information in this document is subject to change without notice. Devices sold by Zilog, Inc. are covered by warranty and patent indemnification provisions appearing in Zilog, Inc. Terms and Conditions of Sale only. Zilog, Inc. makes no warranty, express, statutory, implied or by description, regarding the information set forth herein or regarding the freedom of the described devices from intellectual property infringement. Zilog, Inc. makes no warranty of merchantability or fitness for any purpose. Zilog, Inc. shall not be responsible for any errors that may appear in this document. Zilog, Inc. makes no commitment to update or keep current the information contained in this document.

Zilog's products are not authorized for use as critical components in life support devices or systems unless a specific written agreement pertaining to such intended use is executed between the customer and Zilog prior to use. Life support devices or systems are those which are intended for surgical implantation into the body, or which sustains life whose failure to perform, when properly used in accordance with instructions for use provided in the labeling, can be reasonably expected to result in significant injury to the user.

Zilog, Inc. 210 East Hacienda Ave.
Campbell, CA 95008-6600
Telephone (408) 370-8000
Telex 910-338-7621
FAX 408 370-8056
Internet: <http://www.zilog.com>