



Z86C96

CMOS Z8®

MICROCONTROLLER

GENERAL DESCRIPTION

The Z86C96 microcontroller introduces a new level of sophistication to single-chip architecture. The Z86C96 is a member of the Z8 single-chip microcontroller family with 256 bytes of general-purpose RAM.

The MCU is housed in 64-pin DIP and 68-pin Leaded Chip-Carrier packages and is manufactured in CMOS technology.

Zilog's CMOS microcontroller offers fast execution, efficient use of memory, sophisticated interrupts, input/output bit manipulation capabilities, and easy hardware/software system expansion along with low cost and low power consumption.

The Z86C96 architecture is characterized by Zilog's 8-bit microcontroller core. The device offers a flexible I/O scheme, an efficient register and address space structure, multiplexed capabilities between address/data, I/O, and a number of ancillary features that are useful in many industrial and advanced consumer applications.

The device applications demand powerful I/O capabilities. The Z86C96 fulfills this with 52 pins dedicated to input and output. These lines are grouped into six 8-bit ports and one

4-bit port. The ports are configurable under software control to provide timing, status signals, serial or parallel I/O with or without handshake, and an address/data bus for interfacing external memory.

There are three basic address spaces available to support this wide range of configuration: program memory, data memory and 236 general-purpose registers.

To unburden the program from coping with the real-time problems such as counting/timing and serial data communication, the Z86C96 offers two on-chip Counter/Timers with a large number of user selectable modes, and a Asynchronous Receiver/Transmitter (UART - see block diagram).

Notes:

All Signals with a preceding front slash, "/", are active Low, e.g.: /B/W (WORD is active Low); /B/W (BYTE is active Low, only).

Power connections follow conventional descriptions below:

Connection	Circuit	Device
Power Ground	V _{CC} GND	V _{DD} V _{SS}

GENERAL DESCRIPTION (Continued)

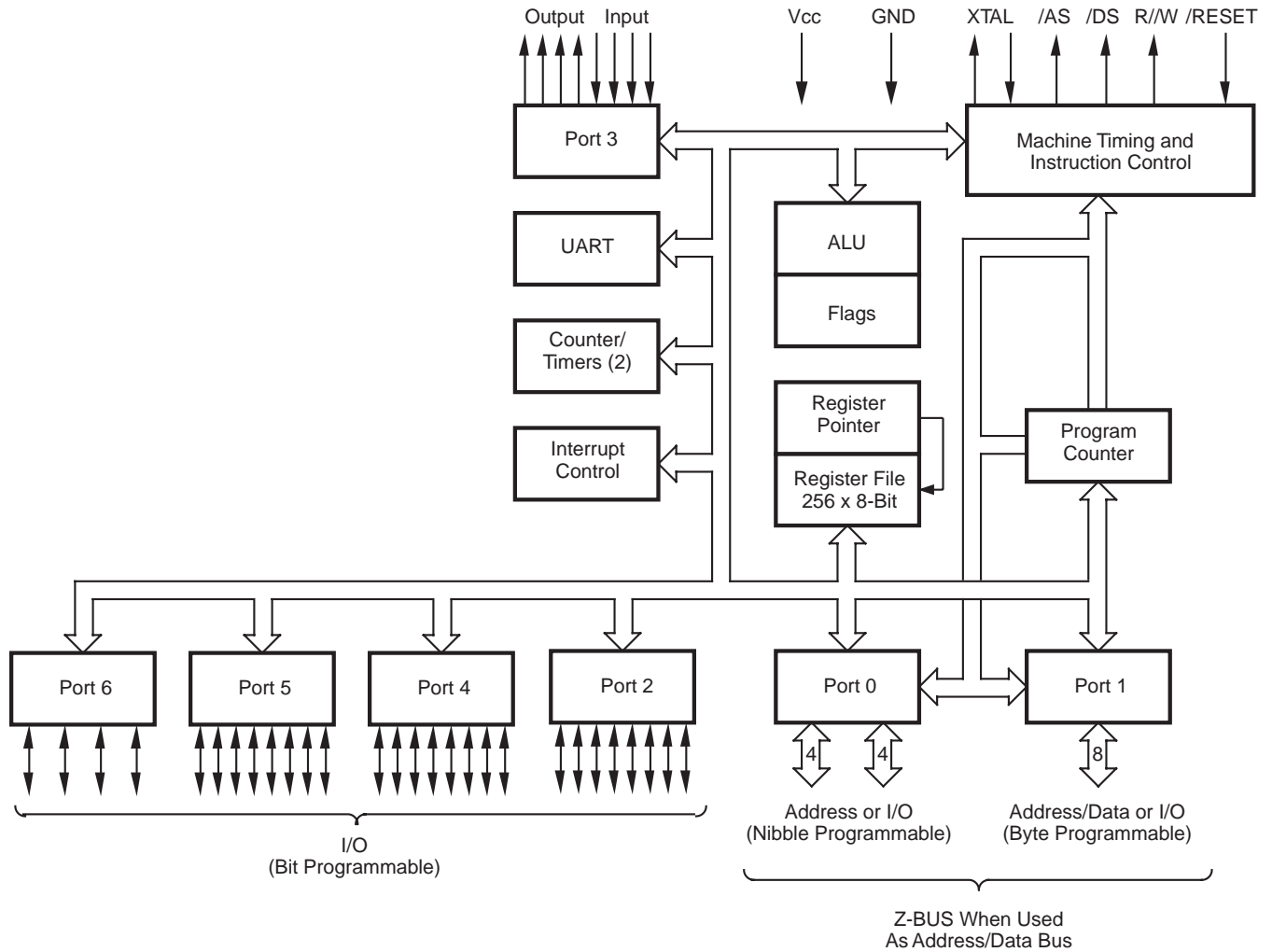

Functional Block Diagram

PIN DESCRIPTION

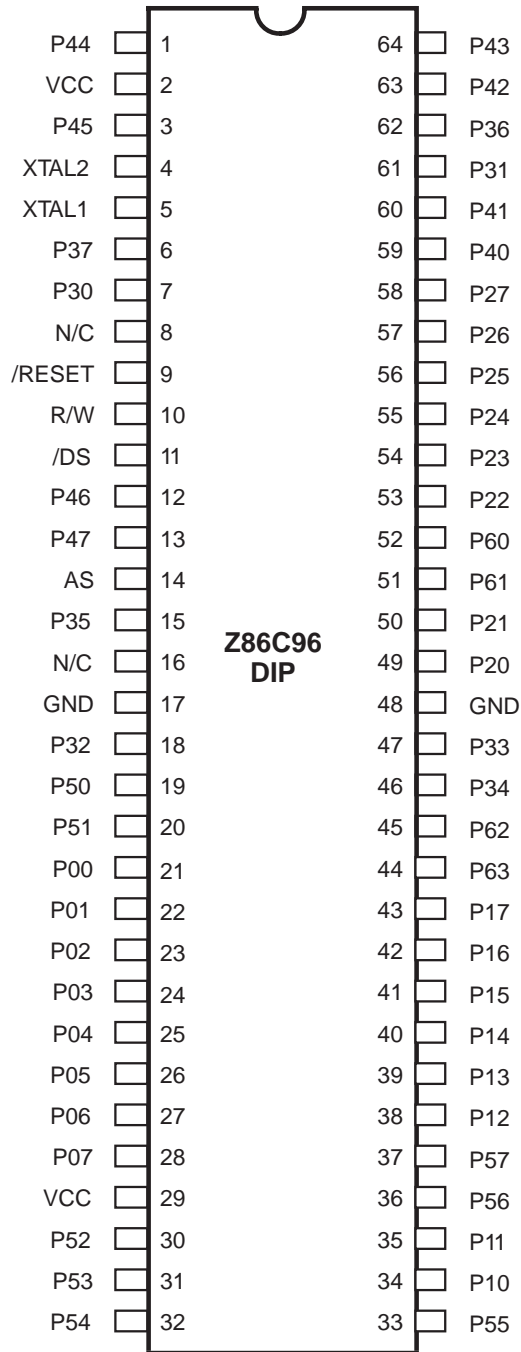

64-Pin Dual In-Line Plastic Pin Assignments

PIN DESCRIPTION (Continued)

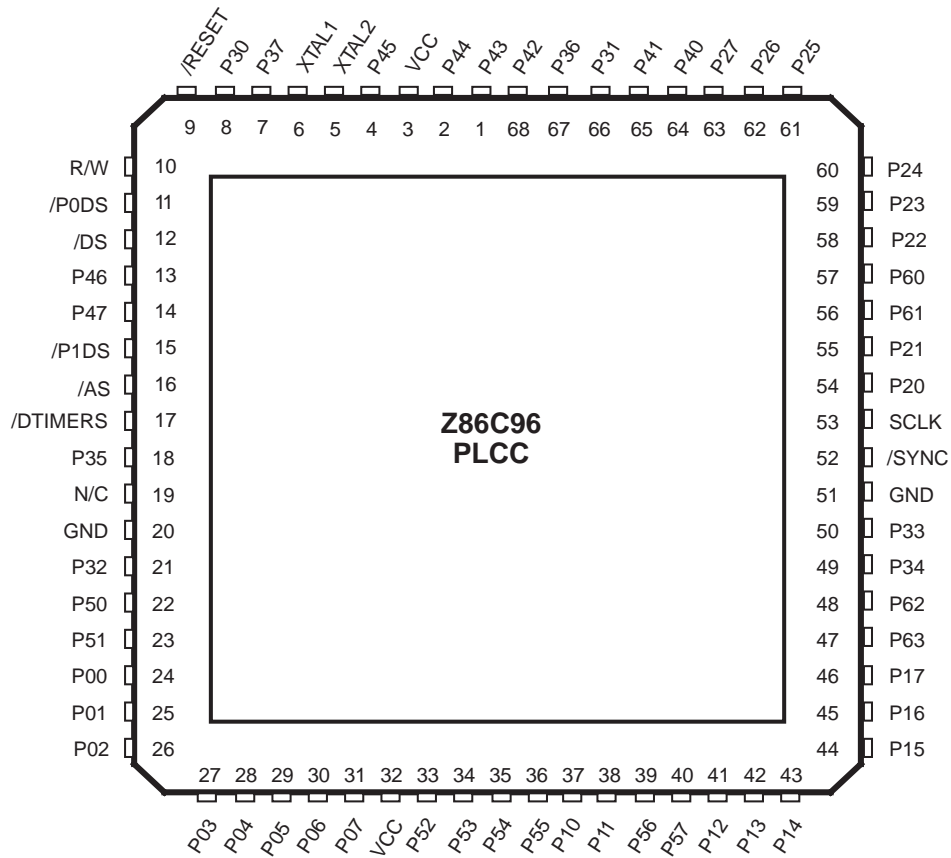

68-Pin Plastic Leaded Chip Carrier Pin Assignments

ABSOLUTE MAXIMUM RATINGS

Symbol	Description	Min	Max	Units
V_{CC}	Supply Voltage*	-0.3	+7.0	V
T_{STG}	Storage Temp	-65	+150°	C
T_A	Oper Ambient Temp		†	C

Notes:

* Voltages on all pins with respect to GND.

† See Ordering Information

Stress greater than those listed under Absolute Maximum Ratings may cause permanent damage to the device. This is a stress rating only; operation of the device at any condition above those indicated in the operational sections of these specifications is not implied. Exposure to absolute maximum rating conditions for an extended period may affect device reliability.

STANDARD TEST CONDITIONS

The characteristics listed below apply for standard test conditions as noted. All voltages are referenced to GND. Positive current flows into the referenced pin (see Test Load Diagram).

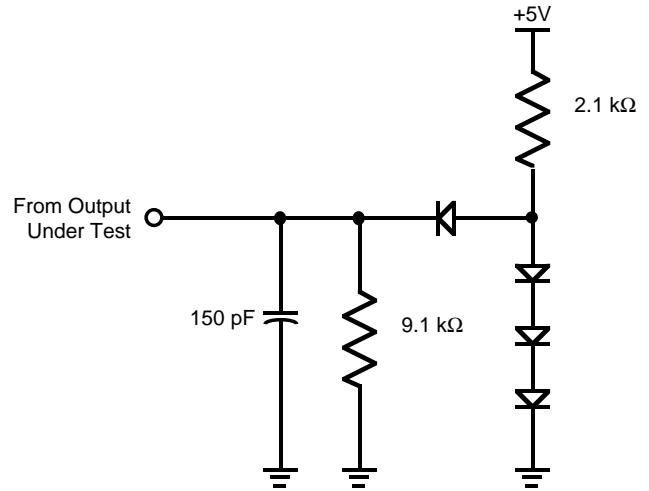

Test Load Diagram

PLEASE NOTE

This device will not operate in extended Timing mode. Set Register 248 (F8H), D5 = 0.

DC CHARACTERISTICS

Sym	Parameter VCC = 4.5 V to 5.5 V	T _A = 0°C to +70°C		T _A = -40°C to +105°C		Typical at 25°C	Units	Conditions
		Min	Max	Min	Max			
	Max Input Voltage		7		7		V	I _{IN} < 250 μA
V _{CH}	Clock Input High Voltage	3.8	V _{CC} +0.3	3.8	V _{CC} +0.3		V	Driven by External Clock Generator
V _{CL}	Clock Input Low Voltage	-0.3	0.8	-0.3	0.8		V	Driven by External Clock Generator
V _{IH}	Input High Voltage	2.0	V _{CC} +0.3	2.0	V _{CC} +0.3		V	
V _{IL}	Input Low Voltage	-0.3	0.8	-0.3	0.8		V	
V _{OH}	Output High Voltage	2.4		2.4			V	I _{OH} = -2.0 mA
V _{OH}	Output High Voltage	V _{CC} -100mV		V _{CC} -100mV			V	I _{OH} = -100 μA
V _{OL}	Output Low Voltage		0.4		0.4		V	I _{OL} = +5.0 mA
V _{RH}	Reset Input High Voltage	3.8	V _{CC} +0.3	3.8	V _{CC} +0.3		V	
V _{RL}	Reset Input Low Voltage	-0.3	0.8	-0.3	0.8		V	
I _{IL}	Input Leakage	-2	2	-2	2		μA	V _{IN} = 0 V, V _{CC}
I _{OL}	Output Leakage	-2	2	-2	2		μA	V _{IN} = 0 V, V _{CC}
I _{IR}	Reset Input Current		-80		-80		μA	V _{RL} = 0 V
I _{CC}	Supply Current		35		35	24	mA	[1] @ 16 MHz
I _{CC1}	Standby Current		6.5		6.5	4	mA	[1] HALT Mode V _{IN} = 0 V, V _{CC} @12 MHz
			7.0		7.0	4.5	mA	[1] HALT Mode V _{IN} = 0 V, V _{CC} @ 16 MHz
I _{CC2}	Standby Current		10		20	5	μA	[1] STOP Mode V _{IN} = 0 V, V _{CC}

Notes:

 [1] All inputs driven to either 0 V or V_{CC}, outputs floating.

AC CHARACTERISTICS

External I/O or Memory Read or Write Timing Diagram

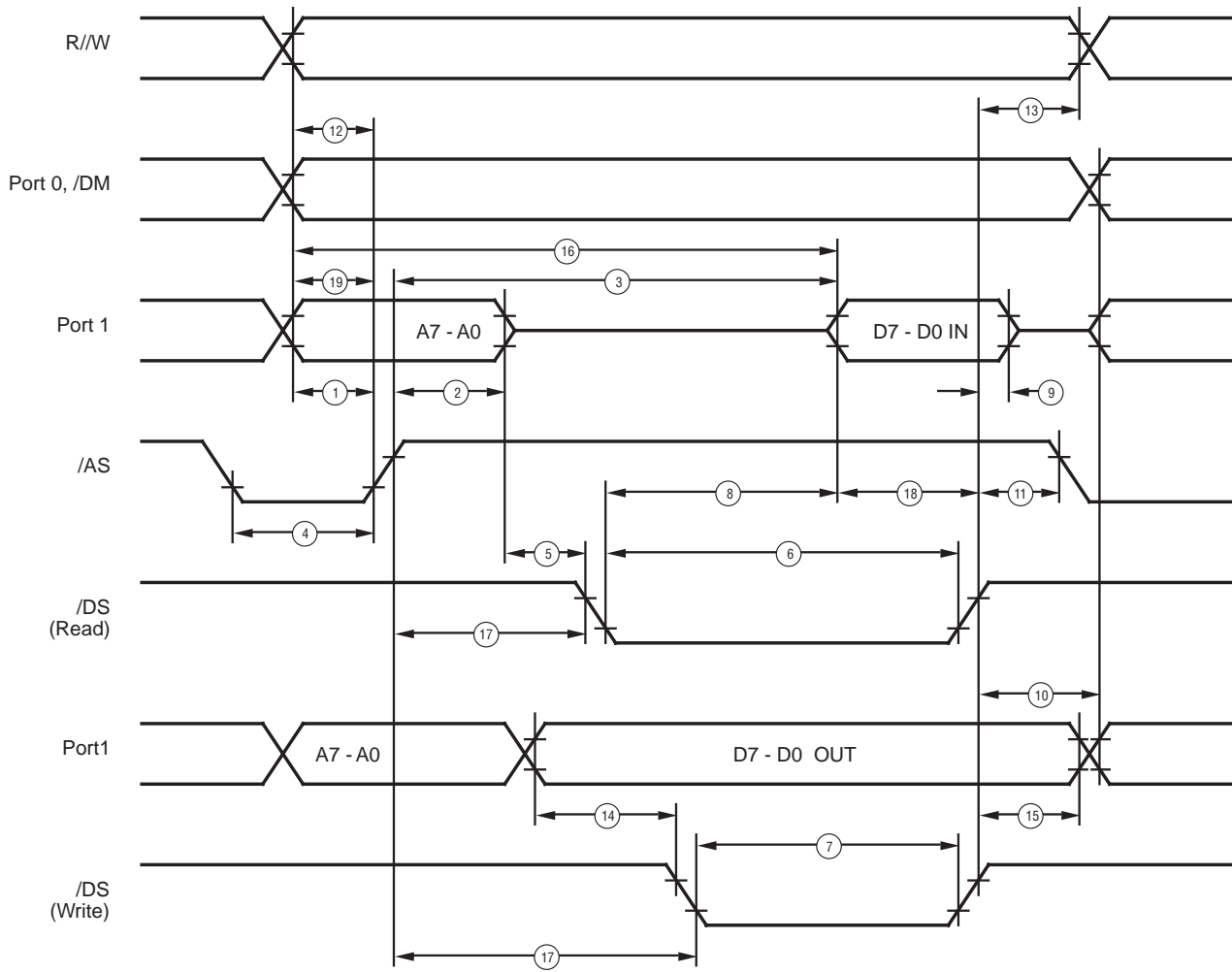

External I/O or Memory Read/Write Timing

AC CHARACTERISTICS

External I/O or Memory Read or Write Timing Table

No	Symbol	Parameter	$T_A = 0^\circ\text{C to } +70^\circ\text{C}$		$T_A = -40^\circ\text{C to } +105^\circ\text{C}$		Units	Notes
			Min	Max	Min	Max		
1	TdA(AS)	Address Valid to /AS Rise Delay	25		25		ns	[2,3]
2	TdAS(A)	/AS Rise to Address Float Delay	35		35		ns	[2,3]
3	TdAS(DR)	/AS Rise to Read Data Req'd Valid		180		180	ns	[1,2,3]
4	TwAS	/AS Low Width	40		40		ns	[2,3]
5	TdAZ(DS)	Address Float to /DS Fall	0		0		ns	
6	TwDSR	/DS (Read) Low Width	135		135		ns	[1,2,3]
7	TwDSW	/DS (Write) Low Width	80		80		ns	[1,2,3]
8	TdDSR(DR)	/DS Fall to Read Data Req'd Valid		75		75	ns	[1,2,3]
9	ThDR(DS)	Read Data to /DS Rise Hold Time	0		0		ns	[2,3]
10	TdDS(A)	/DS Rise to Address Active Delay	50		50		ns	[2,3]
11	TdDS(AS)	/DS Rise to /AS Fall Delay	35		35		ns	[2,3]
12	TdR/W(AS)	R/W Valid to /AS Rise Delay	20		25		ns	[2,3]
13	TdDS(R/W)	/DS Rise to R/W Not Valid	35		35		ns	[2,3]
14	TdDW(DSW)	Write Data Valid to /DS Fall (Write) Delay	25		25		ns	[2,3]
15	TdDS(DW)	/DS Rise to Write Data Not Valid Delay	35		35		ns	[2,3]
16	TdA(DR)	Address Valid to Read Data Req'd Valid		230		230	ns	[1,2,3]
17	TdAS(DS)	/AS Rise to /DS Fall Delay		45		45	ns	[2,3]
18	TdDI(DS)	Data Input Setup to /DS Rise		60		60	ns	[1,2,3]
19	TdDM(AS)	/DM Valid to /AS Rise Delay		30		30	ns	[2,3]

Notes:

- [1] When using extended memory timing add 2 TpC.
 [2] Timing numbers given are for minimum TpC.
 [3] See Clock Dependent Formulas table.

Standard Test Load

All timing references use 2.0 V for a logic 1 and 0.8 V for a logic 0.

Clock Dependent Formulas

Number	Symbol	Equation
1	TdA(AS)	$0.40 \text{ TpC} + 0.32$
2	TdAS(A)	$0.59 \text{ TpC} - 3.25$
3	TdAS(DR)	$2.83 \text{ TpC} + 6.14$
4	TwAS	$0.66 \text{ TpC} - 1.65$
6	TwDSR	$2.33 \text{ TpC} - 10.56$
7	TwDSW	$1.27 \text{ TpC} + 1.67$
8	TdDSR(DR)	$1.97 \text{ TpC} - 42.5$
10	TdDS(A)	0.8 TpC
11	TdDS(AS)	$0.59 \text{ TpC} - 3.14$
12	TdR/W(AS)	0.4 TpC
13	TdDS(R/W)	$0.8 \text{ TpC} - 15$
14	TdDW(DSW)	0.4 TpC
15	TdDS(DW)	$0.88 \text{ TpC} - 19$
16	TdA(DR)	$4 \text{ TpC} - 20$
17	TdAS(DS)	$0.91 \text{ TpC} - 10.7$
18	TsDI(DS)	$0.8 \text{ TpC} - 10$
19	TdDM(AS)	$0.9 \text{ TpC} - 26.3$

AC CHARACTERISTICS

Additional Timing Diagram

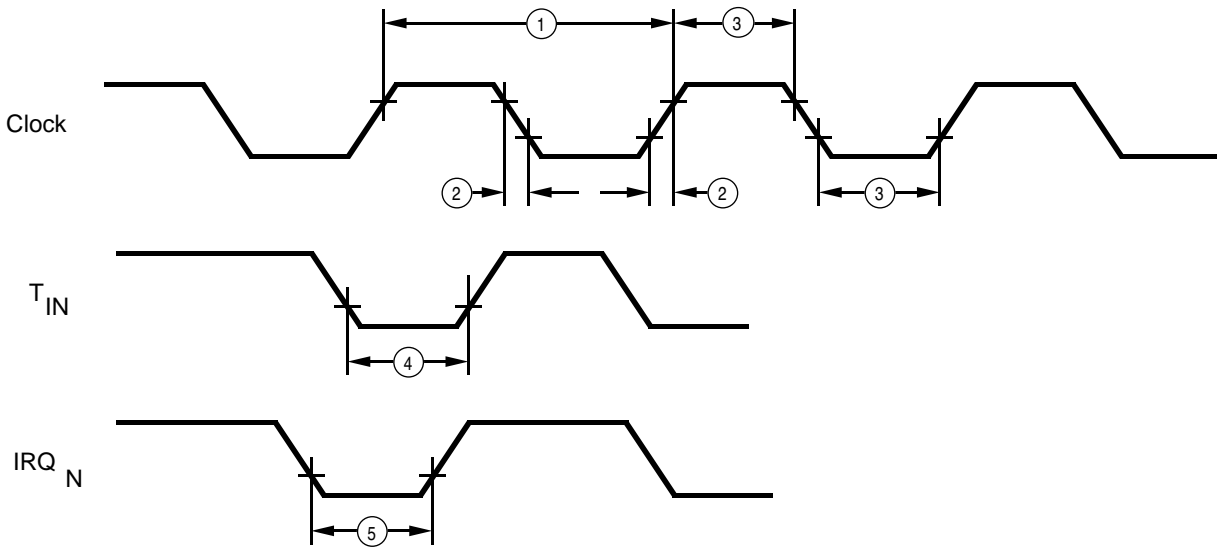

Additional Timing

AC CHARACTERISTICS

Additional Timing Table

No	Symbol	Parameter	$T_A = 0^\circ\text{C to } +70^\circ\text{C}$		$T_A = -40^\circ\text{C to } +105^\circ\text{C}$		Units	Notes
			16 MHz		16 MHz			
			Min	Max	Min	Max		
1	T_{pC}	Input Clock Period	62.5	1000	62.5	1000	ns	[1]
2	T_{rC}, T_{fC}	Clock Input Rise & Fall Times		10		10	ns	[1]
3	T_{wC}	Input Clock Width	25		25		ns	[1]
4	T_{wTinL}	Timer Input Low Width	75		75		ns	[2]
5	T_{wTinH}	Timer Input High Width	$3T_{pC}$		$3T_{pC}$			[2]
6	T_{pTin}	Timer Input Period	$8T_{pC}$		$8T_{pC}$			[2]
7	T_{rTin}, T_{fTin}	Timer Input Rise & Fall Times	100		100		ns	[2]
8A	T_{wL}	Interrupt Request Input Low Times	70		50		ns	[2,4]
8B	T_{wL}	Interrupt Request Input Low Times	$3T_{pC}$		$3T_{pC}$			[2,5]
9	T_{wH}	Interrupt Request Input High Times	$3T_{pC}$		$3T_{pC}$			[2,3]

Notes:

- [1] Clock timing references use 3.8 V for a logic 1 and 0.8 V for a logic 0.
- [2] Timing references use 2.0 V for a logic 1 and 0.8 V for a logic 0.
- [3] Interrupt references request through Port 3.
- [4] Interrupt request through Port 3 (P33-P31).
- [5] Interrupt request through Port 30.

AC CHARACTERISTICS
Handshake Timing Diagrams

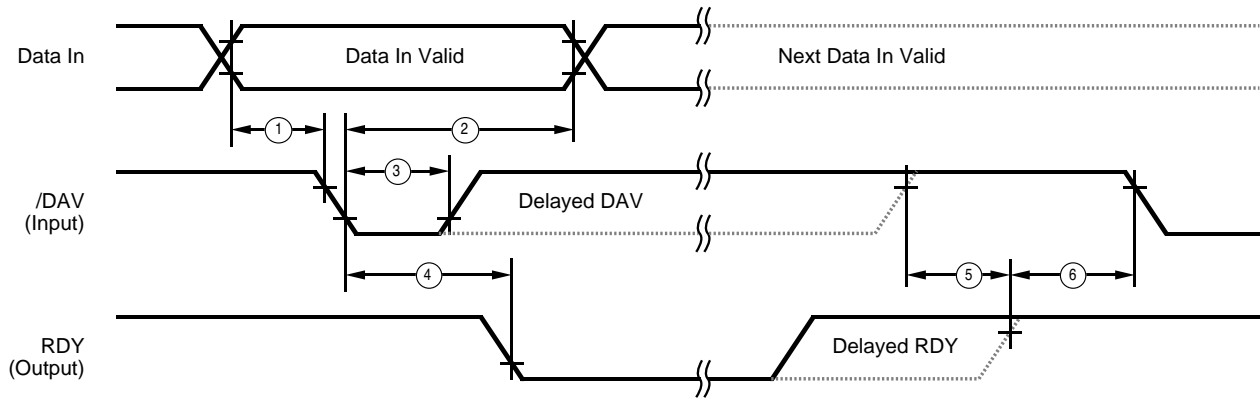

Input Handshake Timing

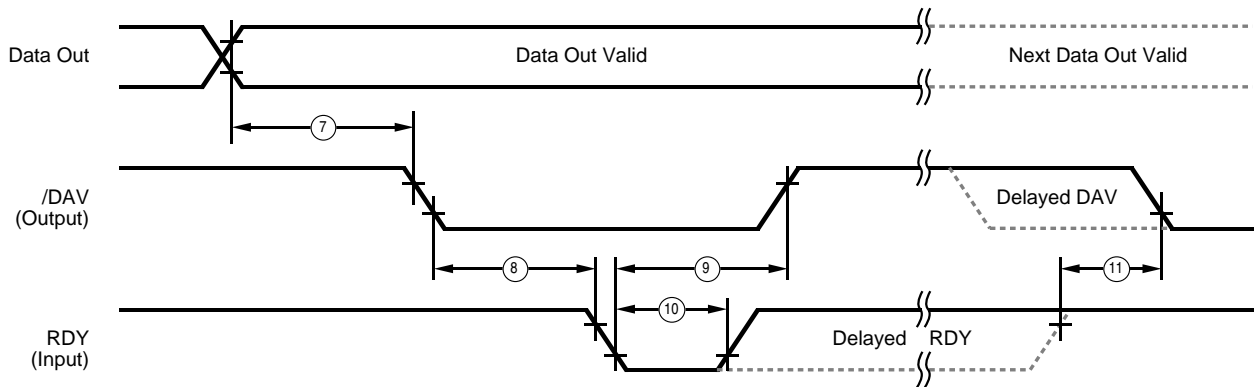

Output Handshake Timing

AC CHARACTERISTICS
Handshake Timing Table

No	Symbol	Parameter	$T_A = 0^{\circ}\text{C to } +70^{\circ}\text{C}$ 16 MHz		$T_A = -40^{\circ}\text{C to } +105^{\circ}\text{C}$ 16 MHz		Data Direction
			Min	Max	Min	Max	
1	TsDI(DAV)	Data In Setup Time	0		0		IN
2	ThDI(DAV)	Data In Hold Time	145		145		IN
3	TwDAV	Data Available Width	110		110		IN
4	TdDAVI(RDY)	DAV Fall to RDY Fall Delay		115		115	IN
5	TdDAVI(d(RDY))	DAV Rise to RDY Rise Delay		115		115	IN
6	TdRDY0(DAV)	RDY Rise to DAV Fall Delay	0		0		IN
7	TdD0(DAV)	Data Out to DAV Fall Delay		TpC		TpC	OUT
8	TdDAV0(RDY)	DAV Fall to RDY Fall Delay	0		0		OUT
9	TdRDY0(DAV)	RDY Fall to DAV Rise Delay		115		115	OUT
10	TwRDY	RDY Width	110		110		OUT
11	TdRDY0d(DAV)	RDY Rise to DAV Fall Delay		115		115	OUT

Low Margin:

Customer is advised that this product does not meet Zilog's internal guardbanded test policies for the specification requested and is supplied on an exception basis. Customer is cautioned that delivery may be uncertain and that, in addition to all other limitations on Zilog

liability stated on the front and back of the acknowledgement, Zilog makes no claim as to quality and reliability under the CPS. The product remains subject to standard warranty for replacement due to defects in materials and workmanship.

© 1993 by Zilog, Inc. All rights reserved. No part of this document may be copied or reproduced in any form or by any means without the prior written consent of Zilog, Inc. The information in this document is subject to change without notice. Devices sold by Zilog, Inc. are covered by warranty and patent indemnification provisions appearing in Zilog, Inc. Terms and Conditions of Sale only. Zilog, Inc. makes no warranty, express, statutory, implied or by description, regarding the information set forth herein or regarding the freedom of the described devices from intellectual property infringement. Zilog, Inc. makes no warranty of merchantability or fitness for any purpose. Zilog, Inc. shall not be responsible for any errors that may appear in this document. Zilog, Inc. makes no commitment to update or keep current the information contained in this document.

Zilog's products are not authorized for use as critical components in life support devices or systems unless a specific written agreement pertaining to such intended use is executed between the customer and Zilog prior to use. Life support devices or systems are those which are intended for surgical implantation into the body, or which sustains life whose failure to perform, when properly used in accordance with instructions for use provided in the labeling, can be reasonably expected to result in significant injury to the user.

Zilog, Inc. 210 East Hacienda Ave.
Campbell, CA 95008-6600
Telephone (408) 370-8000
Telex 910-338-7621
FAX 408 370-8056