



*Z8F082x/Z8F081x/Z8F042x/
Z8F041x*

*Z8 Encore![®] Z8F082x Series
Microcontrollers with Flash
Memory and 10-Bit A/D Converter*

Product Specification

PS019707-1003

Preliminary



This publication is subject to replacement by a later edition. To determine whether a later edition exists, or to request copies of publications, contact:

ZiLOG Worldwide Headquarters

532 Race Street
San Jose, CA 95126
Telephone: 408.558.8500
Fax: 408.558.8300
www.ZiLOG.com

Document Disclaimer

ZiLOG is a registered trademark of ZiLOG Inc. in the United States and in other countries. All other products and/or service names mentioned herein may be trademarks of the companies with which they are associated.

©2003 by ZiLOG, Inc. All rights reserved. Information in this publication concerning the devices, applications, or technology described is intended to suggest possible uses and may be superseded. ZiLOG, INC. DOES NOT ASSUME LIABILITY FOR OR PROVIDE A REPRESENTATION OF ACCURACY OF THE INFORMATION, DEVICES, OR TECHNOLOGY DESCRIBED IN THIS DOCUMENT. ZiLOG ALSO DOES NOT ASSUME LIABILITY FOR INTELLECTUAL PROPERTY INFRINGEMENT RELATED IN ANY MANNER TO USE OF INFORMATION, DEVICES, OR TECHNOLOGY DESCRIBED HEREIN OR OTHERWISE. Devices sold by ZiLOG, Inc. are covered by warranty and limitation of liability provisions appearing in the ZiLOG, Inc. Terms and Conditions of Sale. ZiLOG, Inc. makes no warranty of merchantability or fitness for any purpose Except with the express written approval of ZiLOG, use of information, devices, or technology as critical components of life support systems is not authorized. No licenses are conveyed, implicitly or otherwise, by this document under any intellectual property rights.



Table of Contents

Introduction	1
Features	1
Part Selection Guide	2
Block Diagram	3
CPU and Peripheral Overview	4
eZ8 CPU Features	4
General Purpose I/O	4
Flash Controller	4
10-Bit Analog-to-Digital Converter	4
UART	5
I ² C	5
Serial Peripheral Interface	5
Timers	5
Interrupt Controller	5
Reset Controller	5
On-Chip Debugger	5
Signal and Pin Descriptions	6
Overview	6
Available Packages	6
Pin Configurations	6
Signal Descriptions	9
Pin Characteristics	11
Address Space	13
Overview	13
Register File	13
Program Memory	14
Data Memory	14
Flash Information Area	14
Register File Address Map	16
Control Register Summary	19
Reset and STOP Mode Recovery	29
Overview	29
Reset Types	29
Reset Sources	30
Power-On Reset	30
Voltage Brown-Out Reset	31



Watch-Dog Timer Reset	32
External Pin Reset	33
STOP Mode Recovery	33
STOP Mode Recovery Using Watch-Dog Timer Time-Out	33
STOP Mode Recovery Using a GPIO Port Pin Transition	34
Low-Power Modes	35
Overview	35
STOP Mode	35
HALT Mode	36
General-Purpose I/O	37
Overview	37
GPIO Port Availability By Device	37
Architecture	37
GPIO Alternate Functions	38
GPIO Interrupts	39
GPIO Control Register Definitions	40
Port A-C Address Registers	40
Port A-C Control Registers	41
Port A-C Input Data Registers	46
Port A-C Output Data Register	47
Interrupt Controller	48
Overview	48
Interrupt Vector Listing	48
Architecture	50
Operation	50
Master Interrupt Enable	50
Interrupt Vectors and Priority	51
Interrupt Assertion	51
Software Interrupt Assertion	51
Interrupt Control Register Definitions	52
Interrupt Request 0 Register	52
Interrupt Request 1 Register	53
Interrupt Request 2 Register	54
IRQ0 Enable High and Low Bit Registers	55
IRQ1 Enable High and Low Bit Registers	56
IRQ2 Enable High and Low Bit Registers	57
Interrupt Edge Select Register	58
Interrupt Control Register	59
Timers	60
Overview	60
Architecture	60



Operation	61
Timer Operating Modes	61
Reading the Timer Count Values	69
Timer Output Signal Operation	69
Timer Control Register Definitions	69
Timer 0-1 High and Low Byte Registers	69
Timer Reload High and Low Byte Registers	70
Timer 0-1 PWM High and Low Byte Registers	72
Timer 0-1 Control Registers	73
Watch-Dog Timer	75
Overview	75
Operation	75
Watch-Dog Timer Refresh	76
Watch-Dog Timer Time-Out Response	76
Watch-Dog Timer Reload Unlock Sequence	77
Watch-Dog Timer Control Register Definitions	78
Watch-Dog Timer Control Register	78
Watch-Dog Timer Reload Upper, High and Low Byte Registers	79
UART	81
Overview	81
Architecture	81
Operation	82
Data Format	82
Transmitting Data using the Polled Method	83
Transmitting Data using the Interrupt-Driven Method	84
Receiving Data using the Polled Method	85
Receiving Data using the Interrupt-Driven Method	85
Clear To Send (CTS) Operation	87
Multiprocessor (9-bit) Mode	87
External Driver Enable	88
UART Interrupts	89
UART Baud Rate Generator	91
UART Control Register Definitions	92
UART Transmit Data Register	92
UART Receive Data Register	93
UART Status 0 Register	93
UART Status 1 Register	95
UART Control 0 and Control 1 Registers	95
UART Address Compare Register	98
UART Baud Rate High and Low Byte Registers	99



Infrared Encoder/Decoder	102
Overview	102
Architecture	102
Operation	103
Transmitting IrDA Data	103
Receiving IrDA Data	104
Infrared Encoder/Decoder Control Register Definitions	106
Serial Peripheral Interface	107
Overview	107
Architecture	107
Operation	108
SPI Signals	109
SPI Clock Phase and Polarity Control	110
Multi-Master Operation	112
Slave Operation	112
Error Detection	113
SPI Interrupts	113
SPI Baud Rate Generator	114
SPI Control Register Definitions	114
SPI Data Register	114
SPI Control Register	115
SPI Status Register	116
SPI Mode Register	118
SPI Diagnostic State Register	119
SPI Baud Rate High and Low Byte Registers	120
I2C Controller	121
Overview	121
Operation	121
SDA and SCL Signals	121
I ² C Interrupts	122
Start and Stop Conditions	122
Write Transaction with a 7-Bit Address	123
Write Transaction with a 10-Bit Address	124
Read Transaction with a 7-Bit Address	125
Read Transaction with a 10-Bit Address	126
I2C Control Register Definitions	127
I2C Data Register	127
I2C Status Register	128
I2C Control Register	129
I2C Baud Rate High and Low Byte Registers	130



I2C Diagnostic State Register	132
I2C Diagnostic Control Register	132
Analog-to-Digital Converter	133
Overview	133
Architecture	133
Operation	134
Automatic Power-Down	134
Single-Shot Conversion	134
Continuous Conversion	135
ADC Control Register Definitions	136
ADC Control Register	136
ADC Data High Byte Register	137
ADC Data Low Bits Register	138
Flash Memory	39
Overview	139
Information Area	140
Operation	141
Timing Using the Flash Frequency Registers	141
Flash Read Protection	142
Flash Write/Erase Protection	142
Byte Programming	143
Page Erase	144
Mass Erase	144
Flash Controller Bypass	144
Flash Controller Behavior in Debug Mode	145
Flash Control Register Definitions	145
Flash Control Register	145
Flash Status Register	146
Flash Page Select Register	147
Flash Sector Protect Register	148
Flash Frequency High and Low Byte Registers	149
Option Bits	150
Overview	150
Operation	150
Option Bit Configuration By Reset	150
Option Bit Address Space	150
Program Memory Address 0000H	151
Program Memory Address 0001H	152
On-Chip Debugger	153
Overview	153
Architecture	153



Operation	154
OCD Interface	154
Debug Mode	155
OCD Data Format	156
OCD Auto-Baud Detector/Generator	156
OCD Serial Errors	157
Breakpoints	157
OCDNTR Register	158
On-Chip Debugger Commands	159
On-Chip Debugger Control Register Definitions	163
OCD Control Register	163
OCD Status Register	165
On-Chip Oscillator	167
Overview	167
Operating Modes	167
Crystal Oscillator Operation	167
Oscillator Operation with an External RC Network	169
Electrical Characteristics	171
Absolute Maximum Ratings	171
DC Characteristics	173
AC Characteristics	175
On-Chip Peripheral AC and DC Electrical Characteristics	177
General Purpose I/O Port Input Data Sample Timing	180
General Purpose I/O Port Output Timing	181
On-Chip Debugger Timing	182
SPI MASTER Mode Timing	183
SPI SLAVE Mode Timing	184
I2C Timing	185
UART Timing	186
eZ8 CPU Instruction Set	188
Assembly Language Programming Introduction	188
Assembly Language Syntax	189
eZ8 CPU Instruction Notation	189
Condition Codes	192
eZ8 CPU Instruction Classes	193
eZ8 CPU Instruction Summary	197
Flags Register	207
Opcode Maps	208
Packaging	212



Ordering Information	216
Part Number Description	218
Precharacterization Product	219
Document Information	219
Document Number Description	219
Customer Feedback Form	219
The Z8 Encore!® Product Specification	219
Customer Information	219
Product Information	220
Return Information	220
Problem Description or Suggestion	221
Index	222



List of Figures

Figure 1.	Z8 Encore!® Block Diagram	3
Figure 2.	Z8F0821 and Z8F0421 in 20-Pin SSOP and PDIP Packages	7
Figure 3.	Z8F0822 and Z8F0422 in 28-Pin SOIC and PDIP Packages	7
Figure 4.	Z8F0811 and Z8F0411 in 20-Pin SSOP and PDIP Packages	8
Figure 5.	Z8F0812 and Z8F0412 in 28-Pin SOIC and PDIP Packages	8
Figure 6.	Power-On Reset Operation)	31
Figure 7.	Voltage Brown-Out Reset Operation	32
Figure 8.	GPIO Port Pin Block Diagram	38
Figure 9.	Interrupt Controller Block Diagram	50
Figure 10.	Timer Block Diagram	61
Figure 11.	UART Block Diagram	82
Figure 12.	UART Asynchronous Data Format without Parity	83
Figure 13.	UART Asynchronous Data Format with Parity	83
Figure 14.	UART Asynchronous Multiprocessor Mode Data Format	87
Figure 15.	UART Driver Enable Signal Timing (shown with 1 Stop Bit and Parity)	89
Figure 16.	UART Receiver Interrupt Service Routine Flow	91
Figure 17.	Infrared Data Communication System Block Diagram	102
Figure 18.	Infrared Data Transmission	104
Figure 19.	Infrared Data Reception	105
Figure 20.	SPI Configured as a Master in a Single Master, Single Slave System	107
Figure 21.	SPI Configured as a Master in a Single Master, Multiple Slave System	108
Figure 22.	SPI Configured as a Slave	108
Figure 23.	SPI Timing When PHASE is 0	111
Figure 24.	SPI Timing When PHASE is 1	112
Figure 25.	7-Bit Addressed Slave Data Transfer Format	123
Figure 26.	10-Bit Addressed Slave Data Transfer Format	124
Figure 27.	Receive Data Transfer Format for a 7-Bit Addressed Slave	125
Figure 28.	Receive Data Format for a 10-Bit Addressed Slave	126
Figure 29.	Analog-to-Digital Converter Block Diagram	134
Figure 30.	Flash Memory Arrangement	140
Figure 31.	On-Chip Debugger Block Diagram	153



Figure 32. Interfacing the On-Chip Debugger's DBG Pin with an RS-232 Interface (1)	154
Figure 33. Interfacing the On-Chip Debugger's DBG Pin with an RS-232 Interface (2)	155
Figure 34. OCD Data Format	156
Figure 35. Recommended 20MHz Crystal Oscillator Configuration	168
Figure 36. Connecting the On-Chip Oscillator to an External RC Network	169
Figure 37. Typical Oscillator Frequency as a Function of the R and C Values	170
Figure 38. ICC Versus System Clock Frequency	174
Figure 39. ICC Versus System Clock Frequency	175
Figure 40. Port Input Sample Timing	180
Figure 41. GPIO Port Output Timing	181
Figure 42. On-Chip Debugger Timing	182
Figure 43. SPI MASTER Mode Timing	183
Figure 44. SPI SLAVE Mode Timing	184
Figure 45. I2C Timing	185
Figure 46. UART Timing with CTS	186
Figure 47. UART Timing without CTS	187
Figure 48. Flags Register	207
Figure 49. Opcode Map Cell Description	208
Figure 50. First Opcode Map	210
Figure 51. Second Opcode Map after 1FH	211
Figure 52. 20-Pin Small Shrink Outline Package (SSOP)	212
Figure 53. 20-Pin Plastic Dual-Inline Package (PDIP)	213
Figure 54. 28-Pin Small Outline Integrated Circuit Package (SOIC)	214
Figure 55. 28-Pin Plastic Dual-Inline Package (PDIP)	215



List of Tables

Table 1.	Z8F082x Family Part Selection Guide	2
Table 2.	Z8F082x Family Package Options	6
Table 3.	Signal Descriptions	9
Table 4.	Pin Characteristics	11
Table 5.	Z8F082x Family Program Memory Maps	14
Table 6.	Z8F082x Family Information Area Map	15
Table 7.	Register File Address Map	16
Table 8.	Reset and STOP Mode Recovery Characteristics and Latency	29
Table 9.	Reset Sources and Resulting Reset Type	30
Table 10.	STOP Mode Recovery Sources and Resulting Action	33
Table 11.	Port Availability by Device and Package Type	37
Table 12.	Port Alternate Function Mapping	39
Table 13.	GPIO Port Registers and Sub-Registers	40
Table 14.	Port A-C GPIO Address Registers (PxADDR)	40
Table 15.	Port A-C Control Registers (PxCTL)	41
Table 16.	Port A-C Data Direction Sub-Registers	42
Table 17.	Port A-C Alternate Function Sub-Registers	42
Table 18.	Port A-C Output Control Sub-Registers	43
Table 19.	Port A-C High Drive Enable Sub-Registers	44
Table 20.	Port A-C STOP Mode Recovery Source Enable Sub-Registers	45
Table 21.	Port A-C Input Data Registers (PxIN)	46
Table 22.	Port A-C Pull-Up Enable Sub-Registers	46
Table 23.	Port A-C Output Data Register (PxOUT)	47
Table 24.	Interrupt Vectors in Order of Priority	49
Table 25.	Interrupt Request 0 Register (IRQ0)	52
Table 26.	Interrupt Request 2 Register (IRQ2)	54
Table 27.	Interrupt Request 1 Register (IRQ1)	54
Table 28.	IRQ0 Enable and Priority Encoding	55
Table 29.	IRQ0 Enable High Bit Register (IRQ0ENH)	55
Table 30.	IRQ1 Enable and Priority Encoding	56
Table 31.	IRQ0 Enable Low Bit Register (IRQ0ENL)	56
Table 32.	IRQ1 Enable Low Bit Register (IRQ1ENL)	57
Table 33.	IRQ2 Enable and Priority Encoding	57



Table 34.	IRQ1 Enable High Bit Register (IRQ1ENH)	57
Table 35.	IRQ2 Enable Low Bit Register (IRQ2ENL)	58
Table 36.	IRQ2 Enable High Bit Register (IRQ2ENH)	58
Table 37.	Interrupt Edge Select Register (IRQES)	59
Table 38.	Interrupt Control Register (IRQCTL)	59
Table 39.	Timer 0-1 High Byte Register (TxH)	70
Table 40.	Timer 0-1 Low Byte Register (TxL)	70
Table 41.	Timer 0-1 Reload High Byte Register (TxRH)	71
Table 42.	Timer 0-1 Reload Low Byte Register (TxRL)	71
Table 43.	Timer 0-1 PWM High Byte Register (TxPWMH)	72
Table 44.	Timer 0-1 PWM Low Byte Register (TxPWML)	72
Table 45.	Timer 0-1 Control Register (TxCTL)	73
Table 46.	Watch-Dog Timer Approximate Time-Out Delays	76
Table 47.	Watch-Dog Timer Control Register (WDTCTL)	78
Table 48.	Watch-Dog Timer Reload Upper Byte Register (WDTU)	79
Table 49.	Watch-Dog Timer Reload High Byte Register (WDTH)	80
Table 50.	Watch-Dog Timer Reload Low Byte Register (WDTL)	80
Table 51.	UART Transmit Data Register (U0TXD)	92
Table 52.	UART Receive Data Register (U0RXD)	93
Table 53.	UART Status 0 Register (U0STAT0)	93
Table 54.	UART Status 1 Register (U0STAT1)	95
Table 55.	UART Control 0 Register (U0CTL0)	95
Table 56.	UART Control 1 Register (U0CTL1)	97
Table 57.	UART Address Compare Register (U0ADDR)	98
Table 58.	UART Baud Rate High Byte Register (U0BRH)	99
Table 59.	UART Baud Rate Low Byte Register (U0BRL)	99
Table 60.	UART Baud Rates	100
Table 61.	SPI Clock Phase (PHASE) and Clock Polarity (CLKPOL) Operation ...	110
Table 62.	SPI Data Register (SPIDATA)	115
Table 63.	SPI Control Register (SPICTL)	115
Table 64.	SPI Status Register (SPISTAT)	117
Table 65.	SPI Mode Register (SPIMODE)	118
Table 66.	SPI Diagnostic State Register (SPIDST)	119
Table 67.	SPI Baud Rate High Byte Register (SPIBRH)	120
Table 68.	SPI Baud Rate Low Byte Register (SPIBRL)	120
Table 69.	I2C Data Register (I2CDATA)	128



Table 70.	I2C Status Register (I2CSTAT)	128
Table 71.	I2C Control Register (I2CCTL)	129
Table 72.	I2C Baud Rate High Byte Register (I2CBRH)	131
Table 73.	I2C Baud Rate Low Byte Register (I2CBRL)	131
Table 74.	I2C Diagnostic State Register (I2CDST)	132
Table 75.	I2C Diagnostic Control Register (I2CDIAG)	132
Table 76.	ADC Control Register (ADCCTL)	136
Table 77.	ADC Data High Byte Register (ADC DH)	137
Table 78.	ADC Data Low Bits Register (ADC DL)	138
Table 79.	Flash Memory Configurations	139
Table 80.	Flash Memory Sector Addresses	139
Table 81.	Z8F082x family Information Area Map	141
Table 82.	Flash Control Register (FCTL)	145
Table 83.	Flash Status Register (FSTAT)	146
Table 84.	Flash Page Select Register (FPS)	147
Table 85.	Flash Sector Protect Register (FPROT)	148
Table 86.	Flash Frequency High Byte Register (FFREQH)	149
Table 87.	Flash Frequency Low Byte Register (FFREQ L)	149
Table 88.	Option Bits At Program Memory Address 0000H	151
Table 89.	Options Bits at Program Memory Address 0001H	152
Table 90.	OCD Baud-Rate Limits	156
Table 91.	On-Chip Debugger Commands	159
Table 92.	OCD Control Register (OCDCTL)	164
Table 93.	OCD Status Register (OCDSTAT)	165
Table 94.	Recommended Crystal Oscillator Specifications (20MHz Operation)	168
Table 95.	Absolute Maximum Ratings	171
Table 96.	DC Characteristics	173
Table 97.	AC Characteristics	175
Table 98.	Power-On Reset and Voltage Brown-Out Electrical Characteristics and Timing	177
Table 99.	Flash Memory Electrical Characteristics and Timing	177
Table 100.	Watch-Dog Timer Electrical Characteristics and Timing	178
Table 101.	Analog-to-Digital Converter Electrical Characteristics and Timing	178
Table 102.	GPIO Port Input Timing	180
Table 103.	GPIO Port Output Timing	181
Table 104.	On-Chip Debugger Timing	182



Table 105. SPI Master Mode Timing	183
Table 106. SPI Slave Mode Timing	184
Table 107. I2C Timing	185
Table 108. UART Timing with CTS	186
Table 109. UART Timing without CTS	187
Table 110. Assembly Language Syntax Example 1	189
Table 111. Assembly Language Syntax Example 2	189
Table 112. Notational Shorthand	190
Table 113. Additional Symbols	191
Table 114. Condition Codes	192
Table 115. Arithmetic Instructions	193
Table 116. Bit Manipulation Instructions	194
Table 117. Block Transfer Instructions	194
Table 118. CPU Control Instructions	195
Table 119. Load Instructions	195
Table 120. Logical Instructions	196
Table 121. Program Control Instructions	196
Table 122. Rotate and Shift Instructions	197
Table 123. eZ8 CPU Instruction Summary	197
Table 124. Opcode Map Abbreviations	209
Table 125. Ordering Information	216



Manual Objectives

This Product Specification provides detailed operating information for the Z8F082x, Z8F081x, Z8F042x, and Z8F041x devices within the Z8 Encore!® Microcontroller (MCU) family of products. Within this document, the Z8F082x, Z8F081x, Z8F042x, and Z8F041x are referred to collectively as Z8 Encore!® or the Z8F082x family unless specifically stated otherwise.

About This Manual

ZiLOG recommends that the user read and understand everything in this manual before setting up and using the product. However, we recognize that there are different styles of learning. Therefore, we have designed this Product Specification to be used either as a *how to* procedural manual or a reference guide to important data.

Intended Audience

This document is written for ZiLOG customers who are experienced at working with microcontrollers, integrated circuits, or printed circuit assemblies.

Manual Conventions

The following assumptions and conventions are adopted to provide clarity and ease of use:

Courier Typeface

Commands, code lines and fragments, bits, equations, hexadecimal addresses, and various executable items are distinguished from general text by the use of the `Courier` typeface. Where the use of the font is not indicated, as in the Index, the name of the entity is presented in upper case.

- Example: `FLAGS[1]` is `smrf`.

Hexadecimal Values

Hexadecimal values are designated by uppercase *H* suffix and appear in the `Courier` typeface.

- Example: R1 is set to `F8H`.

Brackets

The square brackets, `[]`, indicate a register or bus.

- Example: for the register `R1[7:0]`, R1 is an 8-bit register, `R1[7]` is the most significant bit, and `R1[0]` is the least significant bit.



Braces

The curly braces, { }, indicate a single register or bus created by concatenating some combination of smaller registers, buses, or individual bits.

- Example: the 12-bit register address {0H, RP[7:4], R1[3:0]} is composed of a 4-bit hexadecimal value (0H) and two 4-bit register values taken from the Register Pointer (RP) and Working Register R1. 0H is the most significant nibble (4-bit value) of the 12-bit register, and R1[3:0] is the least significant nibble of the 12-bit register.

Parentheses

The parentheses, (), indicate an indirect register address lookup.

- Example: (R1) is the memory location referenced by the address contained in the Working Register R1.

Parentheses/Bracket Combinations

The parentheses, (), indicate an indirect register address lookup and the square brackets, [], indicate a register or bus.

- *Example:* assume PC[15:0] contains the value 1234h. (PC[15:0]) then refers to the contents of the memory location at address 1234h.

Use of the Words *Set*, *Reset* and *Clear*

The word *set* implies that a register bit or a condition contains a logical 1. The words *reset* or *clear* imply that a register bit or a condition contains a logical 0. When either of these terms is followed by a number, the word *logical* may not be included; however, it is implied.

Notation for Bits and Similar Registers

A field of bits within a register is designated as: Register[n:n].

- Example: ADDR[15:0] refers to bits 15 through bit 0 of the Address.

Use of the Terms *LSB*, *MSB*, *lsb*, and *msb*

In this document, the terms *LSB* and *MSB*, when appearing in upper case, mean *least significant byte* and *most significant byte*, respectively. The lowercase forms, *lsb* and *msb*, mean *least significant bit* and *most significant bit*, respectively.

Use of Initial Uppercase Letters

Initial uppercase letters designate settings and conditions in general text.

- Example 1: The receiver forces the SCL line to Low.
- Example 2: The Master can generate a Stop condition to abort the transfer.



Use of All Uppercase Letters

The use of all uppercase letters designates the names of states, modes, and commands.

- Example 1: The bus is considered BUSY after the Start condition.
- Example 2: A START command triggers the processing of the initialization sequence.
- Example 3: STOP mode.

Bit Numbering

Bits are numbered from 0 to $n-1$ where n indicates the total number of bits. For example, the 8 bits of a register are numbered from 0 to 7.

Safeguards

It is important that all users understand the following safety terms, which are defined here.



Caution: Indicates a procedure or file may become corrupted if the user does not follow directions.

Trademarks

ZiLOG, eZ8, Z8 Encore!, and Z8 are trademarks of [ZiLOG, Inc.](#) in the U.S.A. and other countries. All other trademarks are the property of their respective corporations.



Introduction

The Z8 Encore!® MCU family of products are the first in a line of ZiLOG microcontroller products based upon the new 8-bit eZ8 CPU. The Z8F082x/Z8F081x/Z8F042x/Z8F041x products, hereafter referred to collectively as the Z8F082x family, expand upon ZiLOG's extensive line of 8-bit microcontrollers. The Flash in-circuit programming capability allows for faster development time and program changes in the field. The new eZ8 CPU is upward compatible with existing Z8® instructions. The rich peripheral set of the Z8 Encore!® makes it suitable for a variety of applications including motor control, security systems, home appliances, personal electronic devices, and sensors.

Features

- eZ8 CPU
- Up to 8KB Flash memory with in-circuit programming capability
- 1KB register RAM
- Optional 2- to 5-channel, 10-bit analog-to-digital converter (ADC)
- Full-duplex UART
- I²C
- Serial peripheral interface (SPI)
- Infrared Data Association (IrDA)-compliant infrared encoder/decoders
- Two 16-bit timers with capture, compare, and PWM capability
- Watch-Dog Timer (WDT) with internal RC oscillator
- 11-19 I/O pins depending upon package
- Programmable priority interrupts
- On-Chip Debugger
- Voltage Brown-out Protection (VBO)
- Power-On Reset (POR)
- 2.7-3.6V operating voltage with 5V-tolerant inputs
- 0° to +70°C standard temperature and -40° to +105°C extended temperature operating ranges



Part Selection Guide

Table 1 identifies the basic features and package styles available for each device within the Z8F082x family product line.

Table 1. Z8F082x Family Part Selection Guide

Part Number	Flash (KB)	RAM (KB)	I/O	16-bit Timers with PWM	ADC Inputs	UARTs with IrDA	I ² C	SPI	Package Pin Counts	
									20	28
Z8F0822	8	1	19	2	5	1	1	1		X
Z8F0821	8	1	11	2	2	1	1		X	
Z8F0812	8	1	19	2	0	1	1	1		X
Z8F0811	8	1	11	2	0	1	1		X	
Z8F0422	4	1	19	2	5	1	1	1		X
Z8F0421	4	1	11	2	2	1	1		X	
Z8F0412	4	1	19	2	0	1	1	1		X
Z8F0411	4	1	11	2	0	1	1		X	

Block Diagram

Figure 1 illustrates the block diagram of the architecture of the Z8F082x family devices.

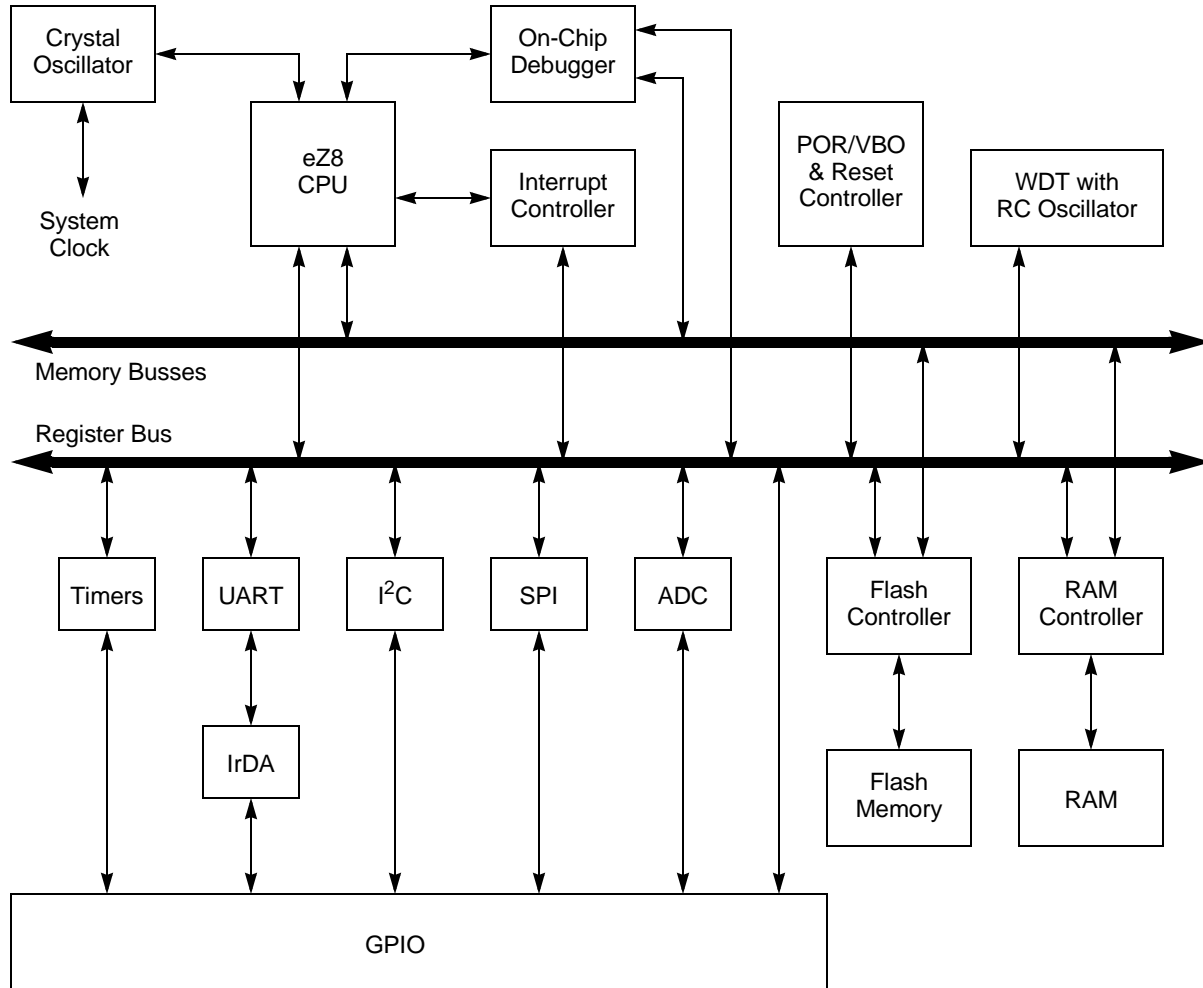

Figure 1. Z8 Encore!® Block Diagram



CPU and Peripheral Overview

eZ8 CPU Features

The eZ8, ZiLOG's latest 8-bit Central Processing Unit (CPU), meets the continuing demand for faster and more code-efficient microcontrollers. The eZ8 CPU executes a superset of the original Z8® instruction set. The eZ8 CPU features include:

- Direct register-to-register architecture allows each register to function as an accumulator, improving execution time and decreasing the required program memory
- Software stack allows much greater depth in subroutine calls and interrupts than hardware stacks
- Compatible with existing Z8® code
- Expanded internal Register File allows access of up to 4KB
- New instructions improve execution efficiency for code developed using higher-level programming languages, including C
- Pipelined instruction fetch and execution
- New instructions for improved performance including BIT, BSWAP, BTJ, CPC, LDC, LDCI, LEA, MULT, and SRL
- New instructions support 12-bit linear addressing of the Register File
- Up to 10 MIPS operation
- C-Compiler friendly
- 2-9 clock cycles per instruction

For more information regarding the eZ8 CPU, refer to the *eZ8 CPU User Manual* available for download at www.zilog.com.

General Purpose I/O

The Z8F082x, Z8F081x, Z8F042x, and Z8F041x feature 11 to 19 port pins (Ports A-C) for general purpose I/O (GPIO). The number of GPIO pins available is a function of package. Each pin is individually programmable.

Flash Controller

The Flash Controller programs and erases the Flash memory.

10-Bit Analog-to-Digital Converter

The optional Analog-to-Digital Converter (ADC) converts an analog input signal to a 10-bit binary number. The ADC accepts inputs from 2 to 5 different analog input sources.



UART

The UART is full-duplex and capable of handling asynchronous data transfers. The UART supports 8- and 9-bit data modes and selectable parity.

I²C

The inter-integrated circuit (I²C®) controller makes the Z8 Encore!® compatible with the I²C protocol. The I²C controller consists of two bidirectional bus lines, a serial data (SDA) line and a serial clock (SCL) line.

Serial Peripheral Interface

The serial peripheral interface (SPI) allows the Z8 Encore!® to exchange data between other peripheral devices such as EEPROMs, A/D converters and ISDN devices. The SPI is a full-duplex, synchronous, character-oriented channel that supports a four-wire interface.

Timers

Two 16-bit reloadable timers can be used for timing/counting events or for motor control operations. These timers provide a 16-bit programmable reload counter and operate in One-Shot, Continuous, Gated, Capture, Compare, Capture and Compare, and PWM modes.

Interrupt Controller

The Z8F082x/Z8F081x/Z8F042x/Z8F041x products support up to 18 interrupts. These interrupts consist of 7 internal peripheral interrupts and 11 general-purpose I/O pin interrupt sources. The interrupts have 3 levels of programmable interrupt priority.

Reset Controller

The Z8F082x family products can be reset using the $\overline{\text{RESET}}$ pin, power-on reset, Watch-Dog Timer (WDT), STOP mode exit, or Voltage Brown-Out (VBO) warning signal.

On-Chip Debugger

The Z8F082x family products feature an integrated On-Chip Debugger (OCD). The OCD provides a rich set of debugging capabilities, such as reading and writing registers, programming the Flash, setting breakpoints and executing code. A single-pin interface provides communication to the OCD.



Signal and Pin Descriptions

Overview

The Z8F082x family products are available in a variety of packages styles and pin configurations. This chapter describes the signals and available pin configurations for each of the package styles. For information regarding the physical package specifications, please refer to the chapter Packaging on page 212.

Available Packages

Table 2 identifies the package styles that are available for each device within the Z8F082x family product line.

Table 2. Z8F082x Family Package Options

Part Number	10-bit ADC	20-pin SSOP and PDIP	28-pin SOIC and PDIP
Z8F0822	Yes		X
Z8F0821	Yes	X	
Z8F0812	No		X
Z8F0811	No	X	
Z8F0422	Yes		X
Z8F0421	Yes	X	
Z8F0412	No		X
Z8F0411	No	X	

Pin Configurations

Figures 2 through 5 illustrate the pin configurations for all of the packages available in the Z8F082x/Z8F081x/Z8F042x/Z8F041x MCU family. Refer to Table 4 for a description of the signals.

- **Note:** The analog input alternate functions (ANAx) are not available on the Z8F081x and Z8F041x devices.

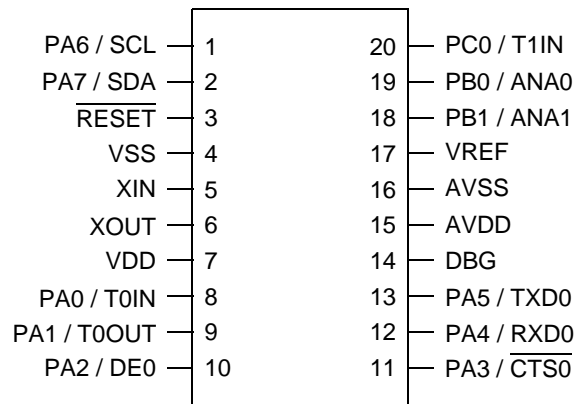

Figure 2. Z8F0821 and Z8F0421 in 20-Pin SSOP and PDIP Packages

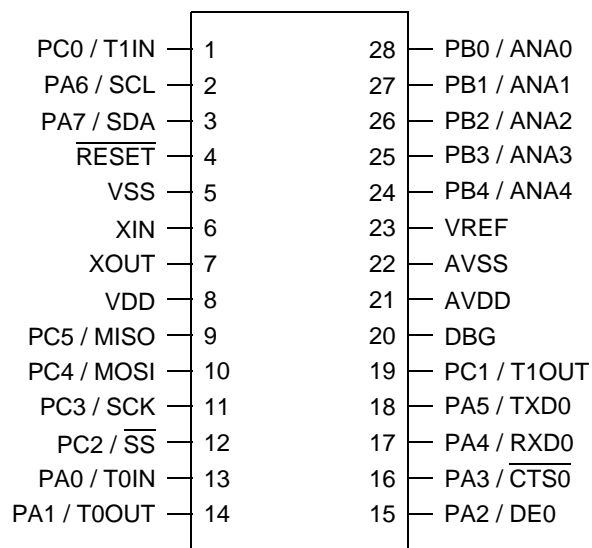

Figure 3. Z8F0822 and Z8F0422 in 28-Pin SOIC and PDIP Packages

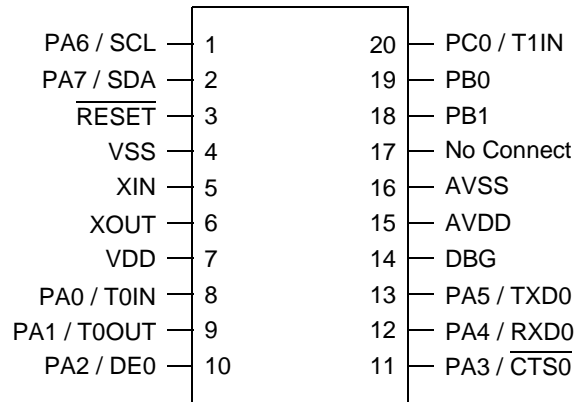

Figure 4. Z8F0811 and Z8F0411 in 20-Pin SSOP and PDIP Packages

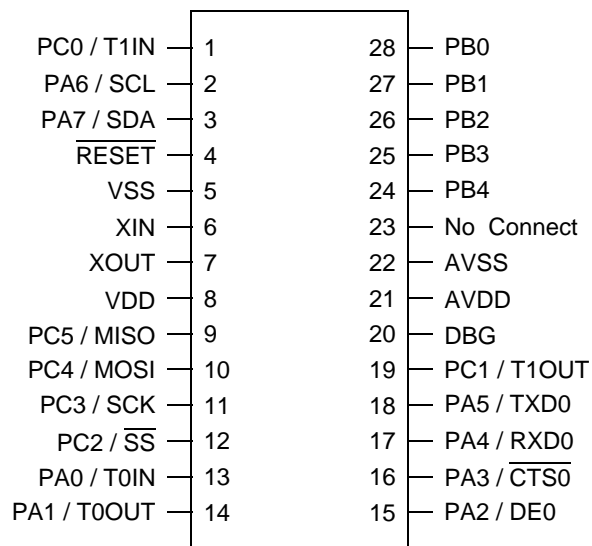

Figure 5. Z8F0812 and Z8F0412 in 28-Pin SOIC and PDIP Packages

Signal Descriptions

Table 3 describes the Z8F082x family signals. Refer to the section **Pin Configurations on page 6** to determine the signals available for the specific package styles.

Table 3. Signal Descriptions

Signal Mnemonic	I/O	Description
General-Purpose I/O Ports A-H		
PA[7:0]	I/O	Port C. These pins are used for general-purpose I/O.
PB[4:0]	I/O	Port B. These pins are used for general-purpose I/O.
PC[5:0]	I/O	Port C. These pins are used for general-purpose I/O.
I²C Controller		
SCL	I/O	Serial Clock. This open-drain pin clocks data transfers in accordance with the I ² C standard protocol. This pin is multiplexed with a general-purpose I/O pin. When the general-purpose I/O pin is configured for alternate function to enable the SCL function, this pin is open-drain.
SDA	I/O	Serial Data. This open-drain pin transfers data between the I ² C and a slave. This pin is multiplexed with a general-purpose I/O pin. When the general-purpose I/O pin is configured for alternate function to enable the SDA function, this pin is open-drain.
SPI Controller		
\overline{SS}	I/O	Slave Select. This signal can be an output or an input. If the Z8 Encore!® is the SPI master, this pin may be configured as the Slave Select output. If the Z8 Encore!™ is the SPI slave, this pin is the input slave select. It is multiplexed with a general-purpose I/O pin.
SCK	I/O	SPI Serial Clock. The SPI master supplies this pin. If the Z8 Encore!® is the SPI master, this pin is an output. If the Z8 Encore!® is the SPI slave, this pin is an input. It is multiplexed with a general-purpose I/O pin.
MOSI	I/O	Master Out Slave In. This signal is the data output from the SPI master device and the data input to the SPI slave device. It is multiplexed with a general-purpose I/O pin.
MISO	I/O	Master In Slave Out. This pin is the data input to the SPI master device and the data output from the SPI slave device. It is multiplexed with a general-purpose I/O pin.
UART Controllers		
TXD0	O	Transmit Data. This signal is the transmit outputs from the UART and IrDA. The TXD signals are multiplexed with general-purpose I/O pins.
RXD0	I	Receive Data. This signal is the receiver inputs for the UART and IrDA. The RXD signals are multiplexed with general-purpose I/O pins.

Table 3. Signal Descriptions (Continued)

Signal Mnemonic	I/O	Description
$\overline{\text{CTS0}}$	I	Clear To Send. This signal is control inputs for the UART. The $\overline{\text{CTS}}$ signals are multiplexed with general-purpose I/O pins.
DE0	O	Driver Enable. This signal allows automatic control of external RS-485 drivers. This signal is approximately the inverse of the TXE (Transmit Empty) bit in the UART Status 0 register. The DE signal may be used to ensure the external RS-485 driver is enabled when data is transmitted by the UART.
Timers		
T0OUT / T1OUT	O	Timer Output 0-1. These signals are output pins from the timers. The Timer Output signals are multiplexed with general-purpose I/O pins.
T0IN / T1IN	I	Timer Input 0-1. These signals are used as the capture, gating and counter inputs. The Timer Input signals are multiplexed with general-purpose I/O pins.
Analog		
ANA[4:0]	I	Analog Input. These signals are inputs to the analog-to-digital converter (ADC). The ADC analog inputs are multiplexed with general-purpose I/O pins.
VREF	I	Analog-to-digital converter reference voltage input. As an output, the VREF signal is not recommended for use as a reference voltage for external devices. If the ADC is configured to use the internal reference voltage generator, this pin should be left unconnected or capacitively coupled to analog ground (AVSS).
Oscillators		
XIN	I	External Crystal Input. This is the input pin to the crystal oscillator. A crystal can be connected between it and the XOUT pin to form the oscillator. In addition, this pin is used with external RC networks or external clock drivers to provide the system clock to the system.
XOUT	O	External Crystal Output. This pin is the output of the crystal oscillator. A crystal can be connected between it and the XIN pin to form the oscillator. When the system clock is referred to in this manual, it refers to the frequency of the signal at this pin. This pin must be left unconnected when not using a crystal.
On-Chip Debugger		
DBG	I/O	Debug. This pin is the control and data input and output to and from the On-Chip Debugger. This pin is open-drain.
 Caution:		For operation of the On-Chip Debugger, all power pins (V_{DD} and AV_{DD}) must be supplied with power and all ground pins (V_{SS} and AV_{SS}) must be properly grounded. The DBG pin is open-drain and must have an external pull-up resistor to ensure proper operation.



Table 3. Signal Descriptions (Continued)

Signal Mnemonic	I/O	Description
Reset		
RESET	I	RESET. Generates a Reset when asserted (driven Low).
Power Supply		
VDD	I	Digital Power Supply.
AVDD	I	Analog Power Supply. Must be powered up and grounded to VDD, even if not using analog features.
VSS	I	Digital Ground.
AVSS	I	Analog Ground. Must be grounded and connected to VSS, even if not using analog features.

Pin Characteristics

Table 4 provides detailed information on the characteristics for each pin available on the Z8F082x family products. Data in Table 4 is sorted alphabetically by the pin symbol mnemonic.

Table 4. Pin Characteristics

Symbol Mnemonic	Direction	Reset Direction	Active Low or Active High	Tri-State Output	Internal Pull-up or Pull-down	Schmitt Trigger Input	Open Drain Output
AVDD	N/A	N/A	N/A	N/A	No	No	N/A
AVSS	N/A	N/A	N/A	N/A	No	No	N/A
DBG	I/O	I	N/A	Yes	No	Yes	Yes
PA[7:0]	I/O	I	N/A	Yes	Programmable Pull-up	Yes	Yes, Programmable
PB[4:0]	I/O	I	N/A	Yes	Programmable Pull-up	Yes	Yes, Programmable
PC[5:0]	I/O	I	N/A	Yes	Programmable Pull-up	Yes	Yes, Programmable
RESET	I	I	Low	N/A	Pull-up	Yes	N/A
VDD	N/A	N/A	N/A	N/A	No	No	N/A
VREF	Analog	N/A	N/A	N/A	No	No	N/A



Table 4. Pin Characteristics (Continued)

Symbol Mnemonic	Direction	Reset Direction	Active Low or Active High	Tri-State Output	Internal Pull-up or Pull-down	Schmitt Trigger Input	Open Drain Output
VSS	N/A	N/A	N/A	N/A	No	No	N/A
XIN	I	I	N/A	N/A	No	No	N/A
XOUT	O	O	N/A	No	No	No	No



Address Space

Overview

The eZ8 CPU can access three distinct address spaces:

- The Register File contains addresses for the general-purpose registers and the eZ8 CPU, peripheral, and general-purpose I/O port control registers.
- The Program Memory contains addresses for all memory locations having executable code and/or data.
- The Data Memory contains addresses for all memory locations that hold data only.

These three address spaces are covered briefly in the following subsections. For more detailed information regarding the eZ8 CPU and its address space, refer to the *eZ8 CPU User Manual* available for download at www.zilog.com.

Register File

The Register File address space in the Z8 Encore!® is 4KB (4096 bytes). The Register File is composed of two sections—control registers and general-purpose registers. When instructions are executed, registers are read from when defined as sources and written to when defined as destinations. The architecture of the eZ8 CPU allows all general-purpose registers to function as accumulators, address pointers, index registers, stack areas, or scratch pad memory.

The upper 256 bytes of the 4KB Register File address space are reserved for control of the eZ8 CPU, the on-chip peripherals, and the I/O ports. These registers are located at addresses from F00H to FFFH. Some of the addresses within the 256-byte control register section are reserved (unavailable). Reading from an reserved Register File addresses returns an undefined value. Writing to reserved Register File addresses is not recommended and can produce unpredictable results.

The on-chip RAM always begins at address 000H in the Register File address space. The Z8F082x, Z8F081x, Z8F042x, and Z8F041x contain 1KB of on-chip RAM. Reading from Register File addresses outside the available RAM addresses (and not within the control register address space) returns an undefined value. Writing to these Register File addresses produces no effect.



Program Memory

The eZ8 CPU supports 64KB of Program Memory address space. The Z8F082x, Z8F081x, Z8F042x, and Z8F041x contain 4KB to 8KB of on-chip Flash memory in the Program Memory address space, depending upon the device. Reading from Program Memory addresses outside the available Flash memory addresses returns FFH. Writing to these unimplemented Program Memory addresses produces no effect. Table 5 describes the Program Memory Maps for the Z8F082x family products.

Table 5. Z8F082x Family Program Memory Maps

Program Memory Address (Hex)	Function
Z8F082x and Z8F081x Products	
0000-0001	Option Bits
0002-0003	Reset Vector
0004-0005	WDT Interrupt Vector
0006-0007	Illegal Instruction Trap
0008-0037	Interrupt Vectors*
0038-1FFF	Program Memory
Z8F042x and Z8F041x Products	
0000-0001	Option Bits
0002-0003	Reset Vector
0004-0005	WDT Interrupt Vector
0006-0007	Illegal Instruction Trap
0008-0037	Interrupt Vectors*
0038-0FFF	Program Memory

* See Table 23 on page 49 for a list of the interrupt vectors.

Data Memory

The Z8F082x family does not use the eZ8 CPU's 64KB Data Memory address space.

Flash Information Area

Table 6 describes the Z8F082x family Flash Information Area. This 512 byte Information Area is accessed by setting bit 7 of the Flash Page Select Register to 1. When access is enabled, the Flash Information Area is mapped into the Program Memory and overlays the 512 bytes at addresses FE00H to FFFFH. When the Information Area access is enabled,



all reads from these Program Memory addresses return the Information Area data rather than the Program Memory data. Access to the Flash Information Area is read-only.

Table 6. Z8F082x Family Information Area Map

Program Memory Address (Hex)	Function
FE00H-FE3FH	Reserved
FE40H-FE53H	Part Number 20-character ASCII alphanumeric code Left justified and filled with zeros
FE54H-FFFFH	Reserved



Register File Address Map

Table 7 provides the address map for the Register File of the Z8F082x family of products. Not all devices and package styles in the Z8F082x family support the ADC, the SPI, or all of the GPIO Ports. Consider registers for unimplemented peripherals as Reserved.

Table 7. Register File Address Map

Address (Hex)	Register Description	Mnemonic	Reset (Hex)	Page #
General Purpose RAM				
000-3FF	General-Purpose Register File RAM	—	XX	
400-EFF	Reserved	—	XX	
Timer 0				
F00	Timer 0 High Byte	T0H	00	69
F01	Timer 0 Low Byte	T0L	01	69
F02	Timer 0 Reload High Byte	T0RH	FF	70
F03	Timer 0 Reload Low Byte	T0RL	FF	70
F04	Timer 0 PWM High Byte	T0PWMH	00	72
F05	Timer 0 PWM Low Byte	T0PWML	00	72
F06	Timer 0 Control 0	T0CTL0	00	73
F07	Timer 0 Control 1	T0CTL1	00	73
Timer 1				
F08	Timer 1 High Byte	T1H	00	69
F09	Timer 1 Low Byte	T1L	01	69
F0A	Timer 1 Reload High Byte	T1RH	FF	70
F0B	Timer 1 Reload Low Byte	T1RL	FF	70
F0C	Timer 1 PWM High Byte	T1PWMH	00	72
F0D	Timer 1 PWM Low Byte	T1PWML	00	72
F0E	Timer 1 Control 0	T1CTL0	00	73
F0F	Timer 1 Control 1	T1CTL1	00	73
F10-F3F	Reserved	—	XX	
UART 0				
F40	UART0 Transmit Data	U0TXD	XX	92
	UART0 Receive Data	U0RXD	XX	93
F41	UART0 Status 0	U0STAT0	0000011Xb	93
F42	UART0 Control 0	U0CTL0	00	95
F43	UART0 Control 1	U0CTL1	00	95
F44	UART0 Status 1	U0STAT1	00	93

XX=Undefined



Table 7. Register File Address Map (Continued)

Address (Hex)	Register Description	Mnemonic	Reset (Hex)	Page #
F45	UART0 Address Compare Register	U0ADDR	00	98
F46	UART0 Baud Rate High Byte	U0BRH	FF	99
F47	UART0 Baud Rate Low Byte	U0BRL	FF	99
F48-F4F	Reserved	—	XX	
I²C				
F50	I ² C Data	I2CDATA	00	127
F51	I ² C Status	I2CSTAT	80	128
F52	I ² C Control	I2CCTL	00	129
F53	I ² C Baud Rate High Byte	I2CBRH	FF	130
F54	I ² C Baud Rate Low Byte	I2CBRL	FF	130
F55	I ² C Diagnostic State	I2CDST	XX000000b	132
F56	I ² C Diagnostic Control	I2CDIAG	00	132
F57-F5F	Reserved	—	XX	
Serial Peripheral Interface (SPI) Unavailable in 20-Pin Package Devices				
F60	SPI Data	SPIDATA	01	114
F61	SPI Control	SPICTL	00	115
F62	SPI Status	SPISTAT	00	116
F63	SPI Mode	SPIMODE	00	118
F64	SPI Diagnostic State	SPIDST	00	119
F65	Reserved	—	XX	
F66	SPI Baud Rate High Byte	SPIBRH	FF	120
F67	SPI Baud Rate Low Byte	SPIBRL	FF	120
F68-F6F	Reserved	—	XX	
Analog-to-Digital Converter (ADC)				
F70	ADC Control	ADCCTL	20	136
F71	Reserved	—	XX	
F72	ADC Data High Byte	ADCDH	XX	137
F73	ADC Data Low Bits	ADCDL	XX	138
F74-FBF	Reserved	—	XX	
Interrupt Controller				
FC0	Interrupt Request 0	IRQ0	00	52
FC1	IRQ0 Enable High Bit	IRQ0ENH	00	55
FC2	IRQ0 Enable Low Bit	IRQ0ENL	00	55
FC3	Interrupt Request 1	IRQ1	00	53
FC4	IRQ1 Enable High Bit	IRQ1ENH	00	56
FC5	IRQ1 Enable Low Bit	IRQ1ENL	00	56
FC6	Interrupt Request 2	IRQ2	00	54
FC7	IRQ2 Enable High Bit	IRQ2ENH	00	57
FC8	IRQ2 Enable Low Bit	IRQ2ENL	00	57
FC9-FCC	Reserved	—	XX	

XX=Undefined



Table 7. Register File Address Map (Continued)

Address (Hex)	Register Description	Mnemonic	Reset (Hex)	Page #
FCD	Interrupt Edge Select	IRQES	00	58
FCE	Reserved	—	00	
FCF	Interrupt Control	IRQCTL	00	59
GPIO Port A				
FD0	Port A Address	PAADDR	00	40
FD1	Port A Control	PACTL	00	41
FD2	Port A Input Data	PAIN	XX	46
FD3	Port A Output Data	PAOUT	00	47
GPIO Port B				
FD4	Port B Address	PBADDR	00	40
FD5	Port B Control	PBCTL	00	41
FD6	Port B Input Data	PBIN	XX	46
FD7	Port B Output Data	PBOUT	00	47
GPIO Port C				
FD8	Port C Address	PCADDR	00	40
FD9	Port C Control	PCCTL	00	41
FDA	Port C Input Data	PCIN	XX	46
FDB	Port C Output Data	PCOUT	00	47
FDC-FEF	Reserved	—	XX	
Watch-Dog Timer (WDT)				
FF0	Watch-Dog Timer Control	WDTCTL	XXX00000b	78
FF1	Watch-Dog Timer Reload Upper Byte	WDTU	FF	80
FF2	Watch-Dog Timer Reload High Byte	WDTH	FF	80
FF3	Watch-Dog Timer Reload Low Byte	WDTL	FF	80
FF4-FF7	Reserved	—	XX	
Flash Memory Controller				
FF8	Flash Control	FCTL	00	145
FF8	Flash Status	FSTAT	00	146
FF9	Flash Page Select	FPS	00	147
FF9 (if enabled)	Flash Sector Protect	FPROT	00	148
FFA	Flash Programming Frequency High Byte	FFREQH	00	149
FFB	Flash Programming Frequency Low Byte	FFREQL	00	149
Read-Only Memory				
eZ8 CPU				
FFC	Flags	—	XX	Refer to the <i>eZ8 CPU User Manual</i>
FFD	Register Pointer	RP	XX	
FFE	Stack Pointer High Byte	SPH	XX	
FFF	Stack Pointer Low Byte	SPL	XX	
XX=Undefined				



Control Register Summary

Timer 0 High Byte

T0H (%F00 - Read/Write)

D7 D6 D5 D4 D3 D2 D1 D0

Timer 0 current count value [15:8]

Timer 0 Low Byte

T0L (%F01 - Read/Write)

D7 D6 D5 D4 D3 D2 D1 D0

Timer 0 current count value [7:0]

Timer 0 Reload High Byte

T0RH (%F02 - Read/Write)

D7 D6 D5 D4 D3 D2 D1 D0

Timer 0 reload value [15:8]

Timer 0 Reload Low Byte

T0RL (%F03 - Read/Write)

D7 D6 D5 D4 D3 D2 D1 D0

Timer 0 reload value [7:0]

Timer 0 PWM High Byte

T0PWMH (%F04 - Read/Write)

D7 D6 D5 D4 D3 D2 D1 D0

Timer 0 PWM value [15:8]

Timer 0 Control 0

T0CTL0 (%F06 - Read/Write)

D7 D6 D5 D4 D3 D2 D1 D0

Reserved
Cascade Timer
0 = Timer 0 Input signal is GPIO pin
1 = Timer 0 Input signal is Timer 1 out
Reserved

Timer 0 Control 1

T0CTL1 (%F07 - Read/Write)

D7 D6 D5 D4 D3 D2 D1 D0

Timer Mode
000 = One-Shot mode
001 = Continuous mode
010 = Counter mode
011 = PWM mode
100 = Capture mode
101 = Compare mode
110 = Gated mode
111 = Capture/Compare mode

Prescale Value
000 = Divide by 1
001 = Divide by 2
010 = Divide by 4
011 = Divide by 8
100 = Divide by 16
101 = Divide by 32
110 = Divide by 64
111 = Divide by 128

Timer Input/Output Polarity
Operation of this bit is a function of the current operating mode of the timer

Timer Enable
0 = Timer is disabled
1 = Timer is enabled

Timer 1 High Byte

T1H (%F08 - Read/Write)

D7 D6 D5 D4 D3 D2 D1 D0

Timer 1 current count value [15:8]

Timer 1 Low Byte

T1L (%F09 - Read/Write)

D7 D6 D5 D4 D3 D2 D1 D0

Timer 1 current count value [7:0]

Timer 1 Reload High Byte

T1RH (%F0A - Read/Write)

D7 D6 D5 D4 D3 D2 D1 D0

Timer 1 reload value [15:8]

Timer 1 Reload Low Byte

T1RL (%F0B - Read/Write)

D7 D6 D5 D4 D3 D2 D1 D0

Timer 1 reload value [7:0]



Timer 1 PWM High Byte

T1PWMH (%F0C - Read/Write)

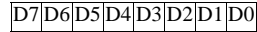

Timer 1 PWM value [15:8]

UART0 Transmit Data

U0TXD (%F40 - Write Only)

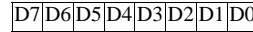

UART0 transmitter data byte [7:0]

Timer 1 PWM Low Byte

T1PWML (%F0D - Read/Write)

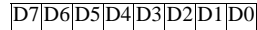

Timer 1 PWM value [7:0]

UART0 Receive Data

U0RXD (%F40 - Read Only)

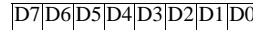

UART0 receiver data byte [7:0]

Timer 1 Control 0

T1CTL0 (%F0E - Read/Write)

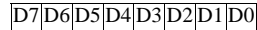

- Reserved
- Cascade Timer
0 = Timer 1 Input signal is GPIO pin
1 = Timer 1 Input signal is Timer 0 out
- Reserved

Timer 1 Control 1

T1CTL1 (%F0F - Read/Write)

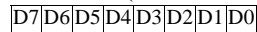

- Timer Mode
000 = One-Shot mode
001 = Continuous mode
010 = Counter mode
011 = PWM mode
100 = Capture mode
101 = Compare mode
110 = Gated mode
111 = Capture/Compare mode
- Prescale Value
000 = Divide by 1
001 = Divide by 2
010 = Divide by 4
011 = Divide by 8
100 = Divide by 16
101 = Divide by 32
110 = Divide by 64
111 = Divide by 128
- Timer Input/Output Polarity
Operation of this bit is a function of the current operating mode of the timer
- Timer Enable
0 = Timer is disabled
1 = Timer is enabled

UART0 Status 0

U0STAT0 (%F41 - Read Only)

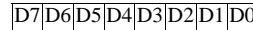

- CTS signal
Returns the level of the CTS signal
- Transmitter Empty
0 = Data is currently transmitting
1 = Transmission is complete
- Transmitter Data Register Empty
0 = Transmit Data Register is full
1 = Transmit Data register is empty
- Break Detect
0 = No break occurred
1 = A break occurred
- Framing Error
0 = No framing error occurred
1 = A framing error occurred
- Overrun Error
0 = No overrun error occurred
1 = An overrun error occurred
- Parity Error
0 = No parity error occurred
1 = A parity error occurred
- Receive Data Available
0 = Receive Data Register is empty
1 = A byte is available in the Receive Data Register



UART0 Control 0

U0CTL0 (%F42 - Read/Write)

D7 D6 D5 D4 D3 D2 D1 D0

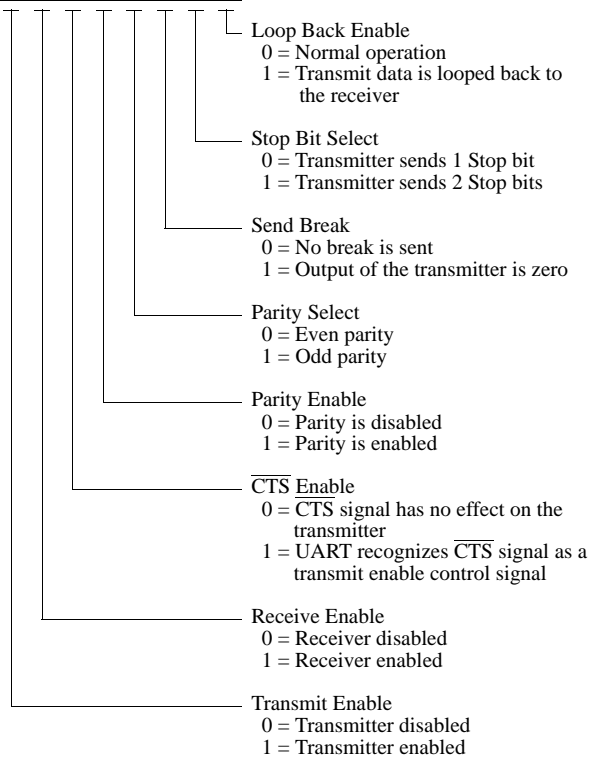

UART0 Control 1

U0CTL1 (%F43 - Read/Write)

D7 D6 D5 D4 D3 D2 D1 D0

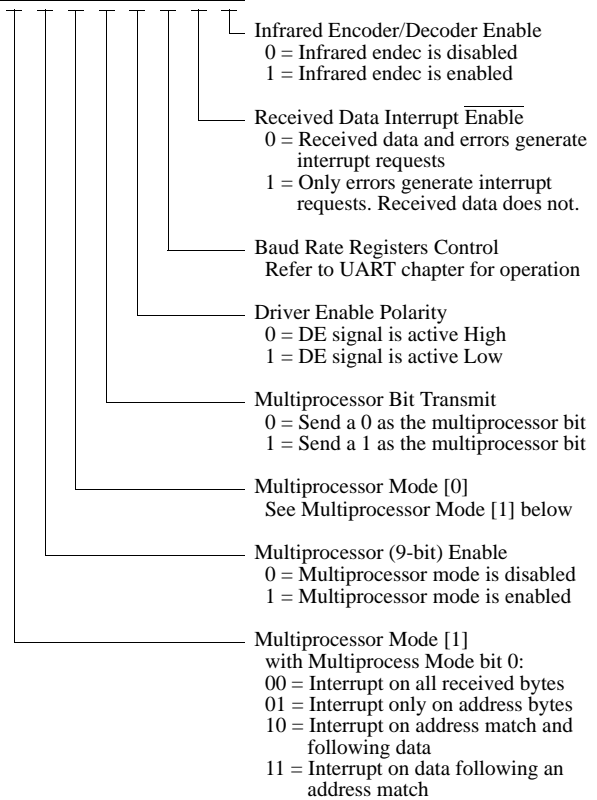

UART0 Status 1

U0STAT1 (%F44- Read Only)

D7 D6 D5 D4 D3 D2 D1 D0

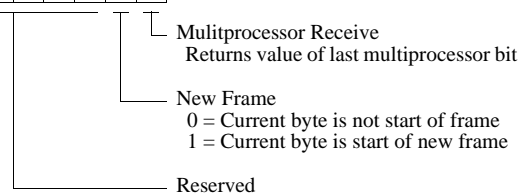

UART0 Address Compare

U0ADDR (%F45 - Read/Write)

D7 D6 D5 D4 D3 D2 D1 D0

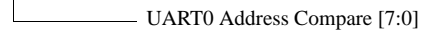



UART0 Baud Rate Generator High Byte

U0BRH (%F46 - Read/Write)

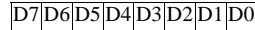

UART0 Baud Rate divisor [15:8]

UART0 Baud Rate Generator Low Byte

U0BRL (%F47 - Read/Write)

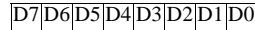

UART0 Baud Rate divisor [7:0]

I2C Data

I2CDATA (%F50 - Read/Write)

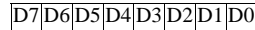

I2C data [7:0]

I2C Status

I2CSTAT (%F51 - Read Only)

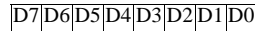

- NACK Interrupt
0 = No action required to service NAK
1 = START/STOP not set after NAK
- Data Shift State
0 = Data is not being transferred
1 = Data is being transferred
- Transmit Address State
0 = Address is not being transferred
1 = Address is being transferred
- Read
0 = Write operation
1 = Read operation
- 10-Bit Address
0 = 7-bit address being transmitted
1 = 10-bit address being transmitted
- Acknowledge
0 = Acknowledge not transmitted/received
1 = For last byte, Acknowledge was transmitted/received
- Receive Data Register Full
0 = I2C has not received data
1 = Data register contains received data
- Transmit Data Register Empty
0 = Data register is full
1 = Data register is empty

I2C Control

I2CCTL (%F52 - Read/Write)

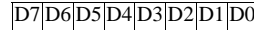

- I2C Signal Filter Enable
0 = Digital filtering disabled
1 = Low-pass digital filters enabled on SDA and SCL input signals
- Flush Data
0 = No effect
1 = Clears I2C Data register
- Send NAK
0 = Do not send NAK
1 = Send NAK after next byte received from slave
- Enable TDRE Interrupts
0 = Do not generate an interrupt when the I2C Data register is empty
1 = Generate an interrupt when the I2C Transmit Data register is empty
- Baud Rate Generator Interrupt Request
0 = Interrupts behave as set by I2C control
1 = BRG generates an interrupt when it counts down to zero
- Send Stop Condition
0 = Do not issue Stop condition after data transmission is complete
1 = Issue Stop condition after data transmission is complete
- Send Start Condition
0 = Do not send Start Condition
1 = Send Start Condition
- I2C Enable
0 = I2C is disabled
1 = I2C is enabled

I2C Baud Rate Generator High Byte

I2CBRH (%F53 - Read/Write)

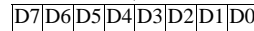

I2C Baud Rate divisor [15:8]

I2C Baud Rate Generator Low Byte

I2CBRL (%F54 - Read/Write)

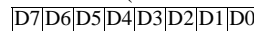

I2C Baud Rate divisor [7:0]



SPI Data

SPIDATA (%F60 - Read/Write)

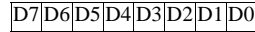

SPI Data [7:0]

SPI Control

SPICTL (%F61 - Read/Write)

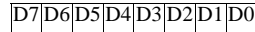

- SPI Enable
0 = SPI disabled
1 = SPI enabled
- Master Mode Enabled
0 = SPI configured in Slave mode
1 = SPI configured in Master mode
- Wire-OR (open-drain) Mode Enabled
0 = SPI signals not configured for open-drain
1 = SPI signals (SCK, \overline{SS} , MISO, and MOSI) configured for open-drain
- Clock Polarity
0 = SCK idles Low
1 = SPI idles High
- Phase Select
Sets the phase relationship of the data to the clock.
- BRG Timer Interrupt Request
0 = BRG timer function is disabled
1 = BRG time-out interrupt is enabled
- Start an SPI Interrupt Request
0 = No effect
1 = Generate an SPI interrupt request
- Interrupt Request Enable
0 = SPI interrupt requests are disabled
1 = SPI interrupt requests are enabled

SPI Status

SPISTAT (%F62 - Read Only)

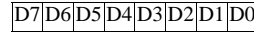

- Slave Select
0 = If Slave, \overline{SS} pin is asserted
1 = If Slave, \overline{SS} pin is not asserted
- Transmit Status
0 = No data transmission in progress
1 = Data transmission now in progress
- Reserved
- Slave Mode Transaction Abort
0 = No slave mode transaction abort detected
1 = Slave mode transaction abort was detected
- Collision
0 = No multi-master collision detected
1 = Multi-master collision was detected
- Overrun
0 = No overrun error detected
1 = Overrun error was detected
- Interrupt Request
0 = No SPI interrupt request pending
1 = SPI interrupt request is pending

SPI Mode

SPIMODE (%F63 - Read/Write)

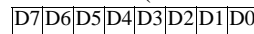

- Slave Select Value
If Master and SPIMODE[1] = 1:
0 = \overline{SS} pin driven Low
1 = \overline{SS} pin driven High
- Slave Select I/O
0 = \overline{SS} pin configured as an input
1 = \overline{SS} pin configured as an output (Master mode only)
- Number of Data Bits Per Character
000 = 8 bits
001 = 1 bit
010 = 2 bits
011 = 3 bits
100 = 4 bits
101 = 5 bit
110 = 6 bits
111 = 7 bits
- Diagnostic Mode Control
0 = Reading from SPIBRH, SPIBRL returns reload values
1 = Reading from SPIBRH, SPIBRL returns current BRG count value
- Reserved



SPI Diagnostic State

SPIDST (%F64 - Read Only)

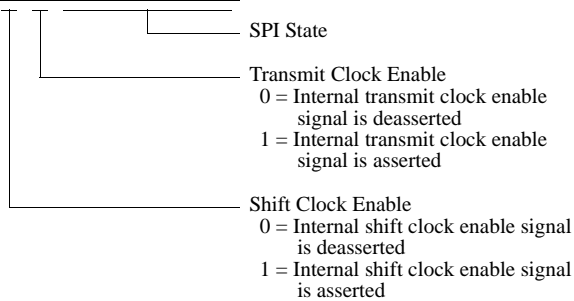
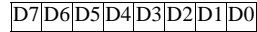

ADC Data High Byte

ADCD_H (%F72 - Read Only)

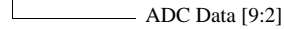
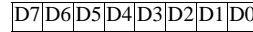

ADC Data Low Bits

ADCD_L (%F73 - Read Only)

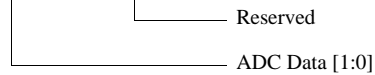
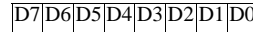

SPI Baud Rate Generator High Byte

SPIBRH (%F66 - Read/Write)

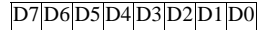

SPI Baud Rate Generator Low Byte

SPIBRL (%F67 - Read/Write)

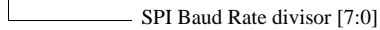
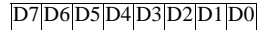

ADC Control

ADCCTL (%F70 - Read/Write)

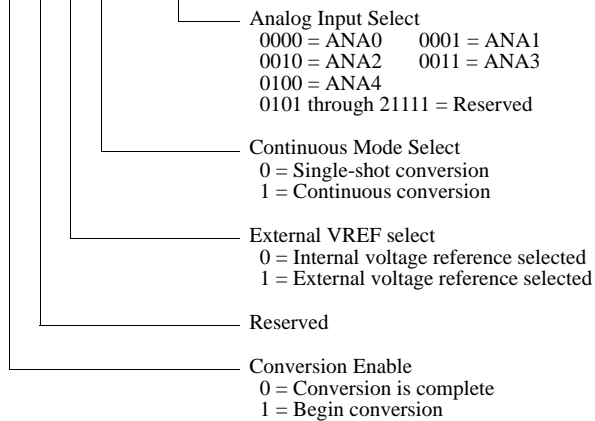
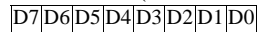

Interrupt Request 0

IRQ0 (%FC0 - Read/Write)

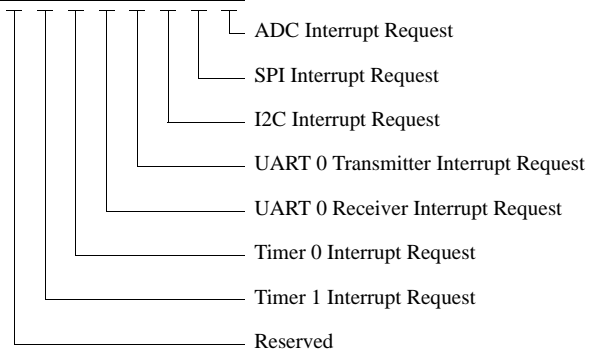
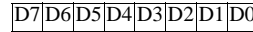

For all of the above peripherals:
0 = Peripheral IRQ is not pending
1 = Peripheral IRQ is awaiting service

IRQ0 Enable High Bit

IRQ0ENH (%FC1 - Read/Write)

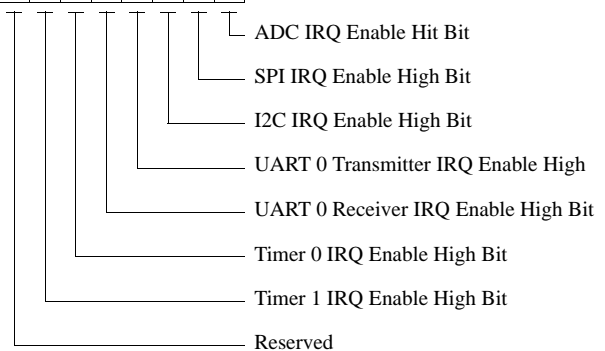
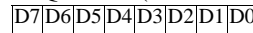



IRQ0 Enable Low Bit

IRQ0ENL (%FC2 - Read/Write)

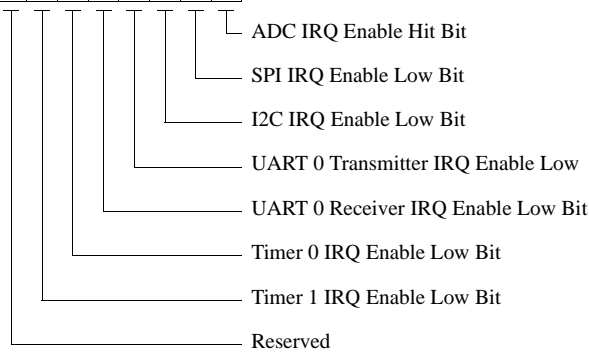

IRQ2 Enable High Bit

IRQ2ENH (%FC7 - Read/Write)

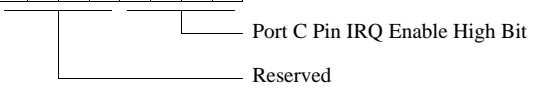
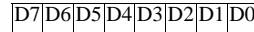

IRQ2 Enable Low Bit

IRQ2ENL (%FC8 - Read/Write)

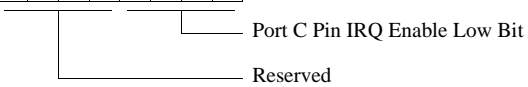
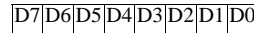

Interrupt Request 1

IRQ1 (%FC3 - Read/Write)

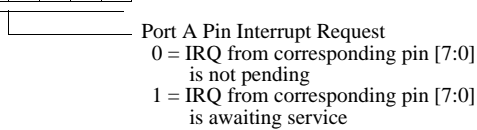
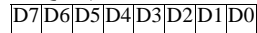

Interrupt Control

IRQES (%FCD - Read/Write)

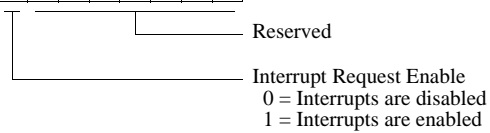
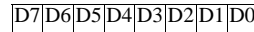

IRQ1 Enable High Bit

IRQ1ENH (%FC4 - Read/Write)

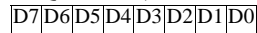

Port A Address

PAADDR (%FD0 - Read/Write)

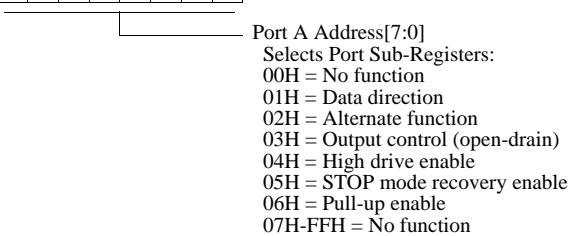

IRQ1 Enable Low Bit

IRQ1ENL (%FC5 - Read/Write)

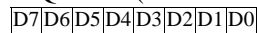

Interrupt Request 2

IRQ2 (%FC6 - Read/Write)

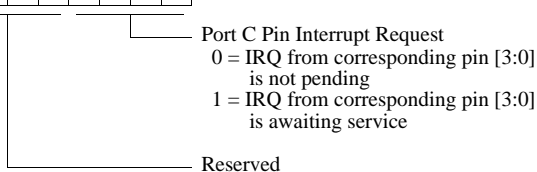

Port A Control

PACTL (%FD1 - Read/Write)

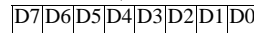



Port A Input Data

PAIN (%FD2 - Read Only)



Port A Input Data [7:0]

Port A Output Data

PAOUT (%FD3 - Read/Write)

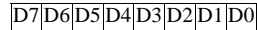

Port A Output Data [7:0]

Port B Address

PBADDR (%FD4 - Read/Write)

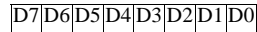

Port B Address[7:0]
Selects Port Sub-Registers:
00H = No function
01H = Data direction
02H = Alternate function
03H = Output control (open-drain)
04H = High drive enable
05H = STOP mode recovery enable
06H = Pull-up enable
07H-FFH = No function

Port B Control

PBCTL (%FD5 - Read/Write)

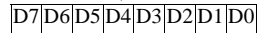

Port B Control [4:0]
Provides Access to Port Sub-Registers
Reserved

Port B Input Data

PBIN (%FD6 - Read Only)



Port B Input Data [4:0]
Reserved

Port B Output Data

PBOUT (%FD7 - Read/Write)

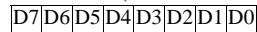

Port B Output Data [4:0]
Reserved

Port C Address

PCADDR (%FD8 - Read/Write)

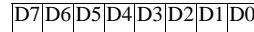

Port C Address[7:0]
Selects Port Sub-Registers:
00H = No function
01H = Data direction
02H = Alternate function
03H = Output control (open-drain)
04H = High drive enable
05H = STOP mode recovery enable
06H = Pull-up enable
07H-FFH = No function

Port C Control

PCCTL (%FD9 - Read/Write)

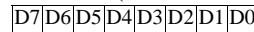

Port C Control [5:0]
Provides Access to Port Sub-Registers
Reserved

Port C Input Data

PCIN (%FDA - Read Only)

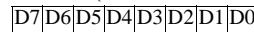

Port C Input Data [5:0]
Reserved

Port C Output Data

PCOUT (%FDB - Read/Write)

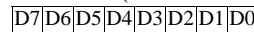

Port C Output Data [5:0]
Reserved



Watch-Dog Timer Control

WDTCTL (%FF0 - Read Only)

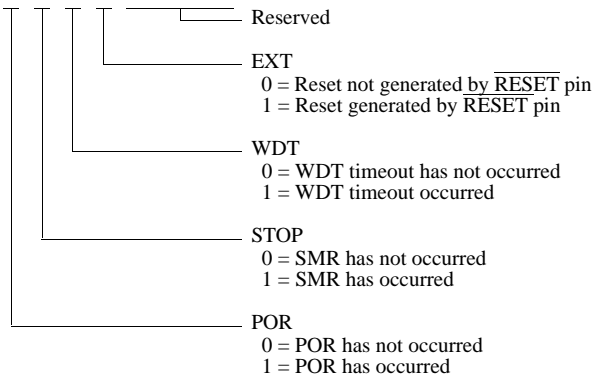
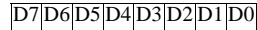

Flash Status

FSTAT (%FF8 - Read Only)

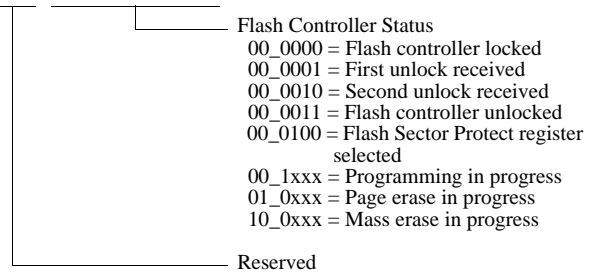
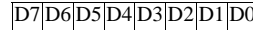

Watch-Dog Timer Reload Upper Byte

WDTU (%FF1 - Read/Write)

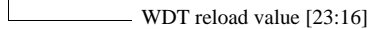
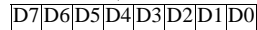

Flash Page Select

FPS (%FF9 - Read/Write)

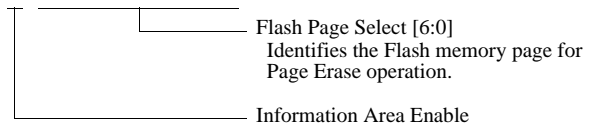
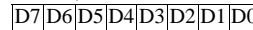

Watch-Dog Timer Reload Middle Byte

WDTH (%FF2 - Read/Write)

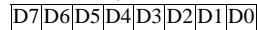

Flash Sector Protect

FPROT (%FF9 - Read/Write to 1's)

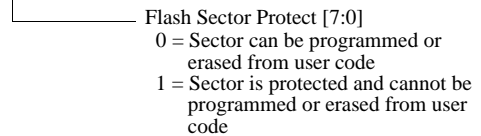
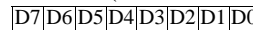

Watch-Dog Timer Reload Low Byte

WDTL (%FF3 - Read/Write)

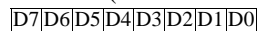

Flash Frequency High Byte

FFREQH (%FFA - Read/Write)

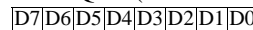

Flash Control

FCTL (%FF8 - Write Only)

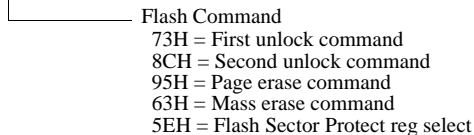
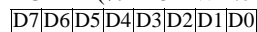

Flash Frequency Low Byte

FFREQL (%FFB - Read/Write)

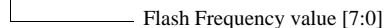
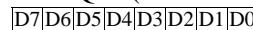



Flags

FLAGS (%FFC - Read/Write)

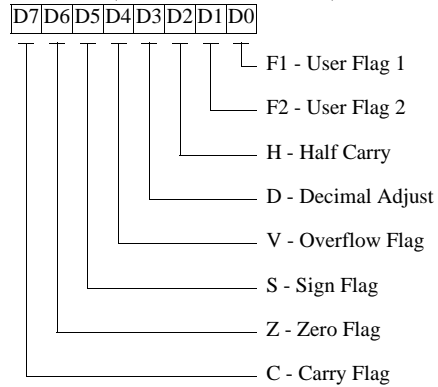

Register Pointer

RP (%FFD - Read/Write)

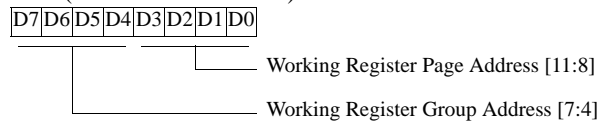

Stack Pointer High Byte

SPH (%FFE - Read/Write)

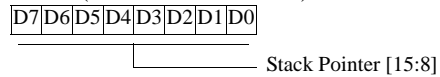

Stack Pointer Low Byte

SPL (%FFF - Read/Write)

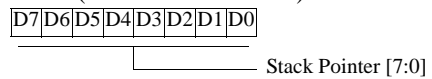



Reset and STOP Mode Recovery

Overview

The Reset Controller within the Z8F082x family controls Reset and STOP Mode Recovery operation. In typical operation, the following events cause a Reset to occur:

- Power-On Reset (POR)
- Voltage Brown-Out (VBO)
- Watch-Dog Timer time-out (when configured via the WDT_RES Option Bit to initiate a Reset)
- External $\overline{\text{RESET}}$ pin assertion
- On-Chip Debugger initiated Reset (OCDCTL[0] set to 1)

When the Z8F082x family device is in STOP mode, a STOP Mode Recovery is initiated by either of the following:

- Watch-Dog Timer time-out
- GPIO Port input pin transition on an enabled STOP Mode Recovery source
- DBG pin driven Low

Reset Types

The Z8F082x family provides two different types of reset operation (System Reset and STOP Mode Recovery). The type of Reset is a function of both the current operating mode of the Z8F082x family device and the source of the Reset. Table 7 lists the types of Reset and their operating characteristics.

Table 7. Reset and STOP Mode Recovery Characteristics and Latency

Reset Type	Reset Characteristics and Latency		
	Control Registers	eZ8 CPU	Reset Latency (Delay)
System Reset	Reset (as applicable)	Reset	66 WDT Oscillator cycles + 16 System Clock cycles
STOP Mode Recovery	Unaffected, except WDT_CTL register	Reset	66 WDT Oscillator cycles + 16 System Clock cycles



System Reset

During a System Reset, the Z8F082x family device is held in Reset for 66 cycles of the Watch-Dog Timer oscillator followed by 16 cycles of the system clock. At the beginning of Reset, all GPIO pins are configured as inputs. All GPIO programmable pull-ups are disabled.

During Reset, the eZ8 CPU and on-chip peripherals are idle; however, the on-chip crystal oscillator and Watch-Dog Timer oscillator continue to run. The system clock begins operating following the Watch-Dog Timer oscillator cycle count. The eZ8 CPU and on-chip peripherals remain idle through the 16 cycles of the system clock.

Upon Reset, control registers within the Register File that have a defined Reset value are loaded with their reset values. Other control registers (including the Stack Pointer, Register Pointer, and Flags) and general-purpose RAM are undefined following Reset. The eZ8 CPU fetches the Reset vector at Program Memory addresses 0002H and 0003H and loads that value into the Program Counter. Program execution begins at the Reset vector address.

Reset Sources

Table 8 lists the reset sources as a function of the operating mode. The text following provides more detailed information on the individual Reset sources. Please note that a Power-On Reset / Voltage Brown-Out event always has priority over all other possible reset sources to insure a full system reset occurs.

Table 8. Reset Sources and Resulting Reset Type

Operating Mode	Reset Source	Reset Type
Normal or HALT modes	Power-On Reset / Voltage Brown-Out	System Reset
	Watch-Dog Timer time-out when configured for Reset	System Reset
	$\overline{\text{RESET}}$ pin assertion	System Reset
	On-Chip Debugger initiated Reset (OCDCTL[0] set to 1)	System Reset except the On-Chip Debugger is unaffected by the reset
STOP mode	Power-On Reset / Voltage Brown-Out	System Reset
	$\overline{\text{RESET}}$ pin assertion	System Reset
	DBG pin driven Low	System Reset

Power-On Reset

Each device in the Z8F082x family contains an internal Power-On Reset (POR) circuit. The POR circuit monitors the supply voltage and holds the device in the Reset state until



the supply voltage reaches a safe operating level. After the supply voltage exceeds the POR voltage threshold (V_{POR}), the POR Counter is enabled and counts 66 cycles of the Watch-Dog Timer oscillator. After the POR counter times out, the XTAL Counter is enabled to count a total of 16 system clock pulses. The device is held in the Reset state until both the POR Counter and XTAL counter have timed out. After the Z8F082x family device exits the Power-On Reset state, the eZ8 CPU fetches the Reset vector. Following Power-On Reset, the POR status bit in the Watch-Dog Timer Control (WDTCTL) register is set to 1.

Figure 6 illustrates Power-On Reset operation. Refer to the **Electrical Characteristics** chapter for the POR threshold voltage (V_{POR}).

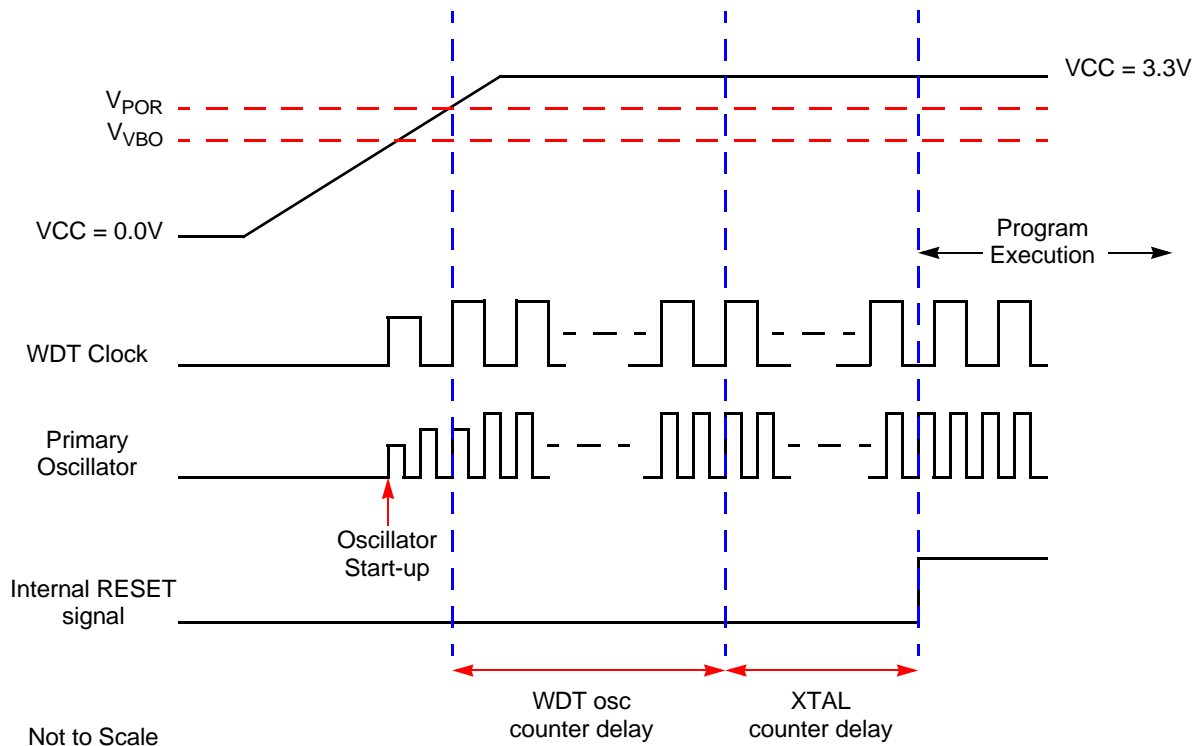

Figure 6. Power-On Reset Operation)

Voltage Brown-Out Reset

The devices in the Z8F082x family provide low Voltage Brown-Out (VBO) protection. The VBO circuit senses when the supply voltage drops to an unsafe level (below the VBO threshold voltage) and forces the device into the Reset state. While the supply voltage remains below the Power-On Reset voltage threshold (V_{POR}), the VBO block holds the device in the Reset state.

After the supply voltage again exceeds the Power-On Reset voltage threshold, the device progresses through a full System Reset sequence, as described in the Power-On Reset section. Following Power-On Reset, the POR status bit in the Watch-Dog Timer Control (WDTCTL) register is set to 1. Figure 7 illustrates Voltage Brown-Out operation. Refer to the **Electrical Characteristics** chapter for the VBO and POR threshold voltages (V_{VBO} and V_{POR}).

The Voltage Brown-Out circuit can be either enabled or disabled during STOP mode. Operation during STOP mode is set by the VBO_AO Option Bit. Refer to the Option Bits chapter for information on configuring VBO_AO.

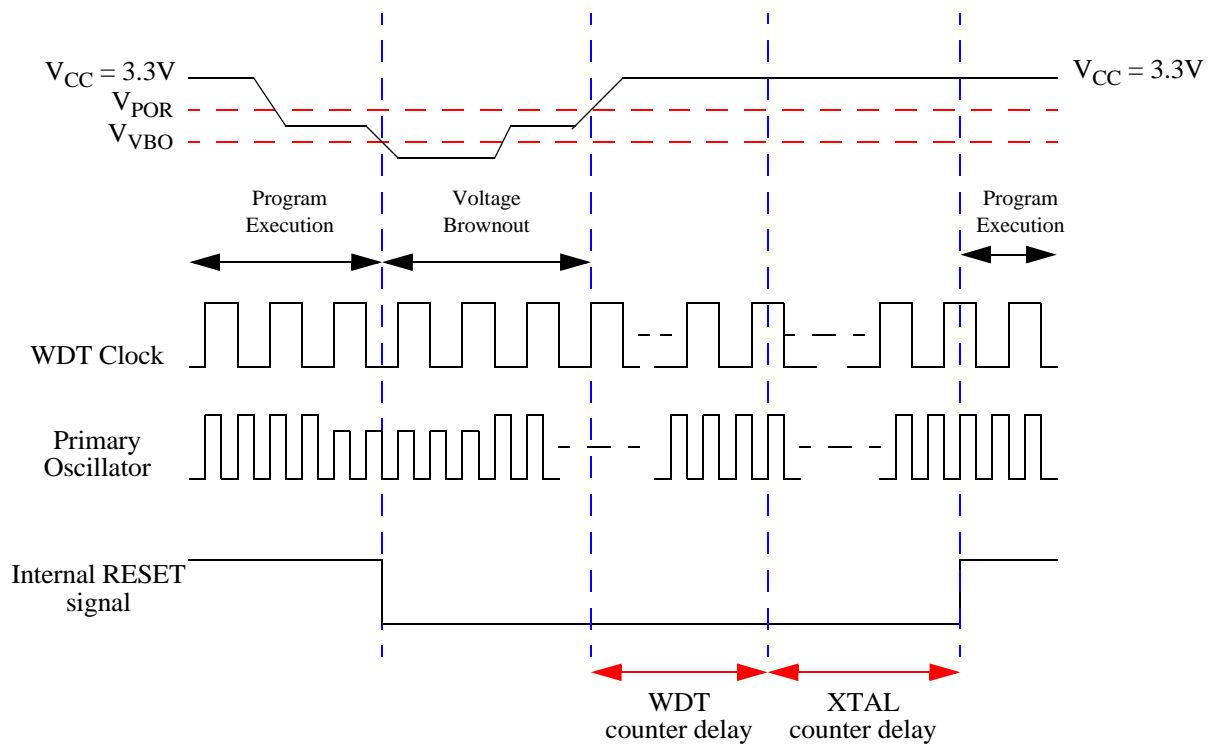

Figure 7. Voltage Brown-Out Reset Operation

Watch-Dog Timer Reset

If the device is in normal or HALT mode, the Watch-Dog Timer can initiate a System Reset at time-out if the WDT_RES Option Bit is set to 1. This is the default (unprogrammed) setting of the WDT_RES Option Bit. The WDT status bit in the WDT Control register is set to signify that the reset was initiated by the Watch-Dog Timer.



External Pin Reset

The $\overline{\text{RESET}}$ pin has a Schmitt-triggered input, an internal pull-up, and a digital filter to reject noise. Once the $\overline{\text{RESET}}$ pin is asserted for at least 4 system clock cycles, the device progresses through the System Reset sequence. While the $\overline{\text{RESET}}$ input pin is asserted Low, the Z8F082x family device continues to be held in the Reset state. If the $\overline{\text{RESET}}$ pin is held Low beyond the System Reset time-out, the device exits the Reset state immediately following $\overline{\text{RESET}}$ pin deassertion. Following a System Reset initiated by the external $\overline{\text{RESET}}$ pin, the EXT status bit in the Watch-Dog Timer Control (WDTCTL) register is set to 1.

STOP Mode Recovery

STOP mode is entered by execution of a STOP instruction by the eZ8 CPU. Refer to the **Low-Power Modes** chapter for detailed STOP mode information. During STOP Mode Recovery, the device is held in reset for 66 cycles of the Watch-Dog Timer oscillator followed by 16 cycles of the system clock. STOP Mode Recovery only affects the contents of the Watch-Dog Timer Control register. Stop Mode recovery does not affect any other values in the Register File, including the Stack Pointer, Register Pointer, Flags, peripheral control registers, and general-purpose RAM.

The eZ8 CPU fetches the Reset vector at Program Memory addresses 0002H and 0003H and loads that value into the Program Counter. Program execution begins at the Reset vector address. Following STOP Mode Recovery, the STOP bit in the Watch-Dog Timer Control Register is set to 1. Table 9 lists the STOP Mode Recovery sources and resulting actions. The text following provides more detailed information on each of the STOP Mode Recovery sources.

Table 9. STOP Mode Recovery Sources and Resulting Action

Operating Mode	STOP Mode Recovery Source	Action
STOP mode	Watch-Dog Timer time-out when configured for Reset	STOP Mode Recovery
	Watch-Dog Timer time-out when configured for interrupt	STOP Mode Recovery followed by interrupt (if interrupts are enabled)
	Data transition on any GPIO Port pin enabled as a STOP Mode Recovery source	STOP Mode Recovery

STOP Mode Recovery Using Watch-Dog Timer Time-Out

If the Watch-Dog Timer times out during STOP mode, the device undergoes a STOP Mode Recovery sequence. In the Watch-Dog Timer Control register, the WDT and STOP bits are set to 1. If the Watch-Dog Timer is configured to generate an interrupt upon time-

out and the Z8F082x family device is configured to respond to interrupts, the eZ8 CPU services the Watch-Dog Timer interrupt request following the normal STOP Mode Recovery sequence.

STOP Mode Recovery Using a GPIO Port Pin Transition

Each of the GPIO Port pins may be configured as a STOP Mode Recovery input source. On any GPIO pin enabled as a Stop Mode Recover source, a change in the input pin value (from High to Low or from Low to High) initiates STOP Mode Recovery. The GPIO STOP Mode Recovery signals are filtered to reject pulses less than 10ns (typical) in duration. In the Watch-Dog Timer Control register, the STOP bit is set to 1.



Caution:

In STOP mode, the GPIO Port Input Data registers (PxIN) are disabled. The Port Input Data registers record the Port transition only if the signal stays on the Port pin through the end of the STOP Mode Recovery delay. Thus, short pulses on the Port pin can initiate STOP Mode Recovery without being written to the Port Input Data register or without initiating an interrupt (if enabled for that pin).



Low-Power Modes

Overview

The Z8F082x family products contain power-saving features. The highest level of power reduction is provided by STOP mode. The next level of power reduction is provided by the HALT mode.

STOP Mode

Execution of the eZ8 CPU's STOP instruction places the device into STOP mode. In STOP mode, the operating characteristics are:

- Primary crystal oscillator is stopped; XIN and XOUT pins are driven Low.
- System clock is stopped
- eZ8 CPU is stopped
- Program counter (PC) stops incrementing
- If enabled for operation in Stop Mode, the Watch-Dog Timer and its internal RC oscillator continue to operate
- If enabled for operation in STOP mode via the associated Option Bit, the Voltage-brown out protection circuit continues to operate
- All other on-chip peripherals are idle

To minimize current in STOP mode, the Watch-Dog Timer should be disabled and all GPIO pins that are configured as digital inputs must be driven to one of the supply rails (V_{CC} or GND). The device can be brought out of STOP mode using STOP Mode Recovery. For more information on STOP Mode Recovery refer to the Reset and STOP Mode Recovery chapter on page 29.



Caution:

STOP Mode should not be used when driving the Z8F082x family devices with an external clock driver source (since the XIN and XOUT pins are driven Low in STOP Mode).



HALT Mode

Execution of the eZ8 CPU's HALT instruction places the device into HALT mode. In HALT mode, the operating characteristics are:

- Primary crystal oscillator is enabled and continues to operate
- System clock is enabled and continues to operate
- eZ8 CPU is stopped
- Program counter (PC) stops incrementing
- Watch-Dog Timer's internal RC oscillator continues to operate
- If enabled, the Watch-Dog Timer continues to operate
- All other on-chip peripherals continue to operate

The eZ8 CPU can be brought out of HALT mode by any of the following operations:

- Interrupt
- Watch-Dog Timer time-out (interrupt or reset)
- Power-on reset
- Voltage-brown out reset
- External $\overline{\text{RESET}}$ pin assertion

To minimize current in HALT mode, all GPIO pins which are configured as inputs must be driven to one of the supply rails (V_{CC} or GND).



General-Purpose I/O

Overview

The Z8F082x family products support a maximum of 19 port pins (Ports A-C) for general-purpose input/output (GPIO) operations. Each port contains control and data registers. The GPIO control registers are used to determine data direction, open-drain, output drive current, programmable pull-ups, STOP Mode Recovery functionality, and alternate pin functions. Each port pin is individually programmable.

GPIO Port Availability By Device

Table 10 lists the port pins available with each device and package type.

Table 10. Port Availability by Device and Package Type

Devices	Package	Port A	Port B	Port C
Z8F0821, Z8F0811, Z8F0421, Z8F0411	20 pin	[7:0]	[1:0]	[0]
Z8F0822, Z8F0812, Z8F0422, Z8F0412	28 pin	[7:0]	[4:0]	[5:0]

Architecture

Figure 8 illustrates a simplified block diagram of a GPIO port pin. In this figure, the ability to accommodate alternate functions, variable port current drive strength, and programmable pull-up are not illustrated.

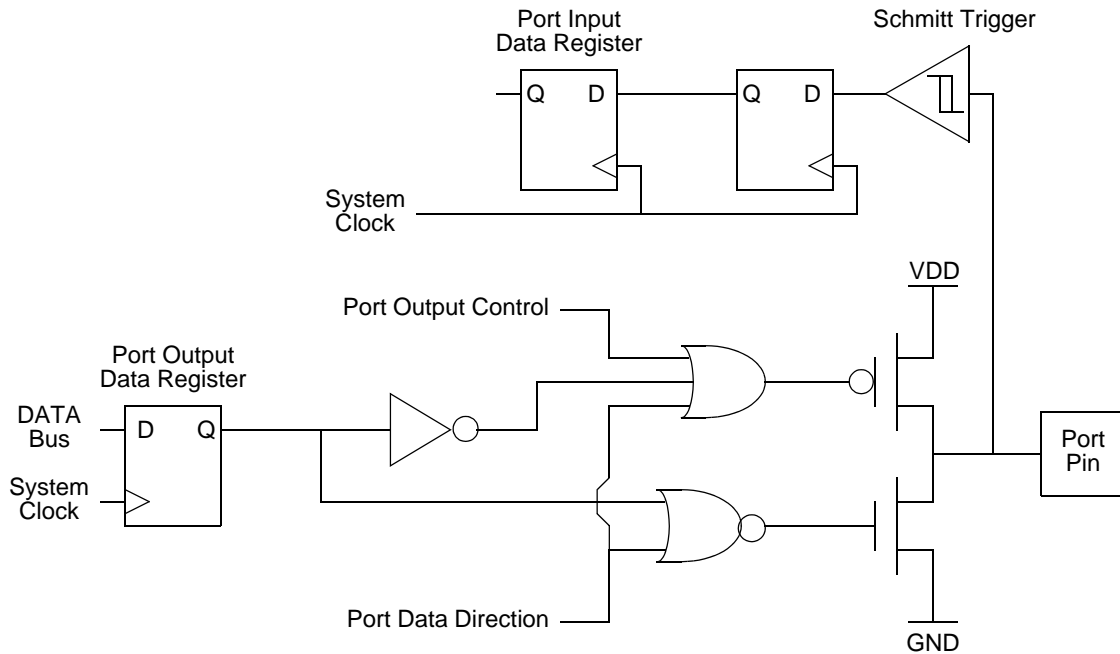

Figure 8. GPIO Port Pin Block Diagram

GPIO Alternate Functions

Many of the GPIO port pins can be used as both general-purpose I/O and to provide access to on-chip peripheral functions such as the timers and serial communication devices. The Port A-C Alternate Function sub-registers configure these pins for either general-purpose I/O or alternate function operation. When a pin is configured for alternate function, control of the port pin direction (input/output) is passed from the Port A-C Data Direction registers to the alternate function assigned to this pin. Table 11 lists the alternate functions associated with each port pin.

Table 11. Port Alternate Function Mapping

Port	Pin	Mnemonic	Alternate Function Description
Port A	PA0	T0IN	Timer 0 Input
	PA1	T0OUT	Timer 0 Output
	PA2	DE	UART 0 Driver Enable
	PA3	$\overline{\text{CTS0}}$	UART 0 Clear to Send
	PA4	RXD0 / IRRX0	UART 0 / IrDA 0 Receive Data
	PA5	TXD0 / IRTX0	UART 0 / IrDA 0 Transmit Data
	PA6	SCL	I ² C Clock (automatically open-drain)
	PA7	SDA	I ² C Data (automatically open-drain)
Port B	PB0	ANA0	ADC Analog Input 0
	PB1	ANA1	ADC Analog Input 1
	PB2	ANA2	ADC Analog Input 2
	PB3	ANA3	ADC Analog Input 3
	PB4	ANA4	ADC Analog Input 4
Port C	PC0	T1IN	Timer 1 Input
	PC1	T1OUT	Timer 1 Output
	PC2	$\overline{\text{SS}}$	SPI Slave Select
	PC3	SCK	SPI Serial Clock
	PC4	MOSI	SPI Master Out Slave In
	PC5	MISO	SPI Master In Slave Out

GPIO Interrupts

Many of the GPIO port pins can be used as interrupt sources. Some port pins may be configured to generate an interrupt request on either the rising edge or falling edge of the pin input signal. Other port pin interrupts generate an interrupt when any edge occurs (both rising and falling). Refer to the **Interrupt Controller** chapter for more information on interrupts using the GPIO pins.



GPIO Control Register Definitions

Four registers for each Port provide access to GPIO control, input data, and output data. Table 12 lists these Port registers. Use the Port A-C Address and Control registers together to provide access to sub-registers for Port configuration and control.

Table 12. GPIO Port Registers and Sub-Registers

Port Register Mnemonic	Port Register Name
PxADDR	Port A-C Address Register (Selects sub-registers)
PxCTL	Port A-C Control Register (Provides access to sub-registers)
PxIN	Port A-C Input Data Register
PxOUT	Port A-C Output Data Register
Port Sub-Register Mnemonic	Port Register Name
PxDD	Data Direction
PxAF	Alternate Function
PxOC	Output Control (Open-Drain)
PxHDE	High Drive Enable
PxSMRE	STOP Mode Recovery Source Enable
PxPUE	Pull-up Enable

Port A-C Address Registers

The Port A-C Address registers select the GPIO Port functionality accessible through the Port A-C Control registers. The Port A-C Address and Control registers combine to provide access to all GPIO Port control (Table 13).

Table 13. Port A-C GPIO Address Registers (PxADDR)

BITS	7	6	5	4	3	2	1	0
FIELD	PADDR[7:0]							
RESET	00H							
R/W	R/W							
ADDR	FD0H, FD4H, FD8H							



PADDR[7:0]—Port Address

The Port Address selects one of the sub-registers accessible through the Port Control register.

PADDR[7:0]	Port Control sub-register accessible using the Port A-C Control Registers
00H	No function. Provides some protection against accidental Port reconfiguration.
01H	Data Direction
02H	Alternate Function
03H	Output Control (Open-Drain)
04H	High Drive Enable
05H	STOP Mode Recovery Source Enable.
06H	Pull-up Enable
07H-FFH	No function.

Port A-C Control Registers

The Port A-C Control registers set the GPIO port operation. The value in the corresponding Port A-C Address register determines the control sub-registers accessible using the Port A-C Control register (Table 14).

Table 14. Port A-C Control Registers (PxCTL)

BITS	7	6	5	4	3	2	1	0
FIELD	PCTL							
RESET	00H							
R/W	R/W							
ADDR	FD1H, FD5H, FD9H							

PCTL[7:0]—Port Control

The Port Control register provides access to all sub-registers that configure the GPIO Port operation.



Port A-C Data Direction Sub-Registers

The Port A-C Data Direction sub-register is accessed through the Port A-C Control register by writing 01H to the Port A-C Address register (Table 15).

Table 15. Port A-C Data Direction Sub-Registers

BITS	7	6	5	4	3	2	1	0
FIELD	DD7	DD6	DD5	DD4	DD3	DD2	DD1	DD0
RESET	1	1	1	1	1	1	1	1
R/W	R/W	R/W	R/W	R/W	R/W	R/W	R/W	R/W
ADDR	If 01H in Port A-C Address Register, accessible via Port A-C Control Register							

DD[7:0]—Data Direction

These bits control the direction of the associated port pin. Port Alternate Function operation overrides the Data Direction register setting.

0 = Output. Data in the Port A-C Output Data register is driven onto the port pin.

1 = Input. The port pin is sampled and the value written into the Port A-C Input Data Register. The output driver is tri-stated.

Port A-C Alternate Function Sub-Registers

The Port A-C Alternate Function sub-register (Table 16) is accessed through the Port A-C Control register by writing 02H to the Port A-C Address register. The Port A-C Alternate Function sub-registers select the alternate functions for the selected pins. Refer to the **GPIO Alternate Functions** section to determine the alternate function associated with each port pin.



Caution:

Do not enable alternate function for GPIO port pins which do not have an associated alternate function. Failure to follow this guideline may result in unpredictable operation.

Table 16. Port A-C Alternate Function Sub-Registers

BITS	7	6	5	4	3	2	1	0
FIELD	AF7	AF6	AF5	AF4	AF3	AF2	AF1	AF0
RESET	0	0	0	0	0	0	0	0
R/W	R/W	R/W	R/W	R/W	R/W	R/W	R/W	R/W
ADDR	If 02H in Port A-C Address Register, accessible via Port A-C Control Register							



AF[7:0]—Port Alternate Function enabled

0 = The port pin is in NORMAL mode and the DDx bit in the Port A-C Data Direction sub-register determines the direction of the pin.

1 = The alternate function is selected. Port pin operation is controlled by the alternate function.

Port A-C Output Control Sub-Registers

The Port A-C Output Control sub-register (Table 17) is accessed through the Port A-C Control register by writing 03H to the Port A-C Address register. Setting the bits in the Port A-C Output Control sub-registers to 1 configures the specified port pins for open-drain operation. These sub-registers affect the pins directly and, as a result, alternate functions are also affected.

Table 17. Port A-C Output Control Sub-Registers

BITS	7	6	5	4	3	2	1	0
FIELD	POC7	POC6	POC5	POC4	POC3	POC2	POC1	POC0
RESET	0	0	0	0	0	0	0	0
R/W	R/W	R/W	R/W	R/W	R/W	R/W	R/W	R/W
ADDR	If 03H in Port A-C Address Register, accessible via Port A-C Control Register							

POC[7:0]—Port Output Control

These bits function independently of the alternate function bit and always disable the drains if set to 1.

0 = The drains are enabled for any output mode (unless overridden by the alternate function).

1 = The drain of the associated pin is disabled (open-drain mode).



Port A-C High Drive Enable Sub-Registers

The Port A-C High Drive Enable sub-register (Table 18) is accessed through the Port A-C Control register by writing 04H to the Port A-C Address register. Setting the bits in the Port A-C High Drive Enable sub-registers to 1 configures the specified port pins for high current output drive operation. The Port A-C High Drive Enable sub-register affects the pins directly and, as a result, alternate functions are also affected.

Table 18. Port A-C High Drive Enable Sub-Registers

BITS	7	6	5	4	3	2	1	0
FIELD	PHDE7	PHDE6	PHDE5	PHDE4	PHDE3	PHDE2	PHDE1	PHDE0
RESET	0	0	0	0	0	0	0	0
R/W	R/W	R/W	R/W	R/W	R/W	R/W	R/W	R/W
ADDR	If 04H in Port A-C Address Register, accessible via Port A-C Control Register							

PHDE[7:0]—Port High Drive Enabled

0 = The Port pin is configured for standard output current drive.

1 = The Port pin is configured for high output current drive.

Port A-C STOP Mode Recovery Source Enable Sub-Registers

The Port A-C STOP Mode Recovery Source Enable sub-register (Table 19) is accessed through the Port A-C Control register by writing 05H to the Port A-C Address register. Setting the bits in the Port A-C STOP Mode Recovery Source Enable sub-registers to 1 configures the specified Port pins as a STOP Mode Recovery source. During Stop Mode, any logic transition on a Port pin enabled as a STOP Mode Recovery source initiates STOP Mode Recovery.



Table 19. Port A-C STOP Mode Recovery Source Enable Sub-Registers

BITS	7	6	5	4	3	2	1	0
FIELD	PSMRE7	PSMRE6	PSMRE5	PSMRE4	PSMRE3	PSMRE2	PSMRE1	PSMRE0
RESET	0	0	0	0	0	0	0	0
R/W	R/W	R/W	R/W	R/W	R/W	R/W	R/W	R/W
ADDR	If 05H in Port A-C Address Register, accessible via Port A-C Control Register							

PSMRE[7:0]—Port STOP Mode Recovery Source Enabled

0 = The Port pin is not configured as a STOP Mode Recovery source. Transitions on this pin during STOP mode do not initiate STOP Mode Recovery.

1 = The Port pin is configured as a STOP Mode Recovery source. Any logic transition on this pin during STOP mode initiates STOP Mode Recovery.

Port A-C Pull-up Enable Sub-Registers

The Port A-C Pull-up Enable sub-register (Table 20) is accessed through the Port A-C Control register by writing 06H to the Port A-C Address register. Setting the bits in the Port A-C Pull-up Enable sub-registers enables a weak internal resistive pull-up on the specified Port pins.



Table 20. Port A-C Pull-Up Enable Sub-Registers

BITS	7	6	5	4	3	2	1	0
FIELD	PPUE7	PPUE6	PPUE5	PPUE4	PPUE3	PPUE2	PPUE1	PPUE0
RESET	0	0	0	0	0	0	0	0
R/W	R/W	R/W	R/W	R/W	R/W	R/W	R/W	R/W
ADDR	If 06H in Port A-C Address Register, accessible via Port A-C Control Register							

PPUE[7:0]—Port Pull-up Enabled
 0 = The weak pull-up on the Port pin is disabled.
 1 = The weak pull-up on the Port pin is enabled.

Port A-C Input Data Registers

Reading from the Port A-C Input Data registers (Table 21) returns the sampled values from the corresponding port pins. The Port A-C Input Data registers are Read-only.

Table 21. Port A-C Input Data Registers (PxIN)

BITS	7	6	5	4	3	2	1	0
FIELD	PIN7	PIN6	PIN5	PIN4	PIN3	PIN2	PIN1	PIN0
RESET	X	X	X	X	X	X	X	X
R/W	R	R	R	R	R	R	R	R
ADDR	FD2H, FD6H, FDAH							

PIN[7:0]—Port Input Data
 Sampled data from the corresponding port pin input.
 0 = Input data is logical 0 (Low).
 1 = Input data is logical 1 (High).



Port A-C Output Data Register

The Port A-C Output Data register (Table 22) controls the output data to the pins.

Table 22. Port A-C Output Data Register (PxOUT)

BITS	7	6	5	4	3	2	1	0
FIELD	POUT7	POUT6	POUT5	POUT4	POUT3	POUT2	POUT1	POUT0
RESET	0	0	0	0	0	0	0	0
R/W	R/W	R/W	R/W	R/W	R/W	R/W	R/W	R/W
ADDR	FD3H, FD7H, FDBH							

POUT[7:0]—Port Output Data

These bits contain the data to be driven to the port pins. The values are only driven if the corresponding pin is configured as an output and the pin is not configured for alternate function operation.

0 = Drive a logical 0 (Low).

1 = Drive a logical 1 (High). High value is not driven if the drain has been disabled by setting the corresponding Port Output Control register bit to 1.



Interrupt Controller

Overview

The interrupt controller on the Z8F082x family products prioritizes the interrupt requests from the on-chip peripherals and the GPIO port pins. The features of the interrupt controller include the following:

- 19 unique interrupt vectors:
 - 12 GPIO port pin interrupt sources
 - 7 on-chip peripheral interrupt sources
- Flexible GPIO interrupts
 - 8 selectable rising and falling edge GPIO interrupts
 - 4 dual-edge interrupts
- 3 levels of individually programmable interrupt priority
- Watch-Dog Timer can be configured to generate an interrupt

Interrupt requests (IRQs) allow peripheral devices to suspend CPU operation in an orderly manner and force the CPU to start an interrupt service routine (ISR). Usually this interrupt service routine is involved with the exchange of data, status information, or control information between the CPU and the interrupting peripheral. When the service routine is completed, the CPU returns to the operation from which it was interrupted.

The eZ8 CPU supports both vectored and polled interrupt handling. For polled interrupts, the interrupt control has no effect on operation. Refer to the *eZ8 CPU User Manual* for more information regarding interrupt servicing by the eZ8 CPU. The *eZ8 CPU User Manual* is available for download at www.zilog.com.

Interrupt Vector Listing

Table 23 lists all of the interrupts available in order of priority. The interrupt vector is stored with the most significant byte (MSB) at the even Program Memory address and the least significant byte (LSB) at the following odd Program Memory address.

**Table 23. Interrupt Vectors in Order of Priority**

	Program Memory	
Priority	Vector Address	Interrupt Source
Highest	0002h	Reset (not an interrupt)
	0004h	Watch-Dog Timer (see the section Watch-Dog Timer on page 75)
	0006h	Illegal Instruction Trap (not an interrupt)
	0008h	Reserved
	000Ah	Timer 1
	000Ch	Timer 0
	000Eh	UART 0 receiver
	0010h	UART 0 transmitter
	0012h	I ² C
	0014h	SPI
	0016h	ADC
	0018h	Port A7, rising or falling input edge
	001Ah	Port A6, rising or falling input edge
	001Ch	Port A5, rising or falling input edge
	001Eh	Port A4, rising or falling input edge
	0020h	Port A3, rising or falling input edge
	0022h	Port A2, rising or falling input edge
	0024h	Port A1, rising or falling input edge
	0026h	Port A0, rising or falling input edge
	0028h	Reserved
	002Ah	Reserved
	002Ch	Reserved
	002Eh	Reserved
	0030h	Port C3, both input edges
	0032h	Port C2, both input edges
	0034h	Port C1, both input edges
Lowest	0036h	Port C0, both input edges

Architecture

Figure 9 illustrates a block diagram of the interrupt controller.

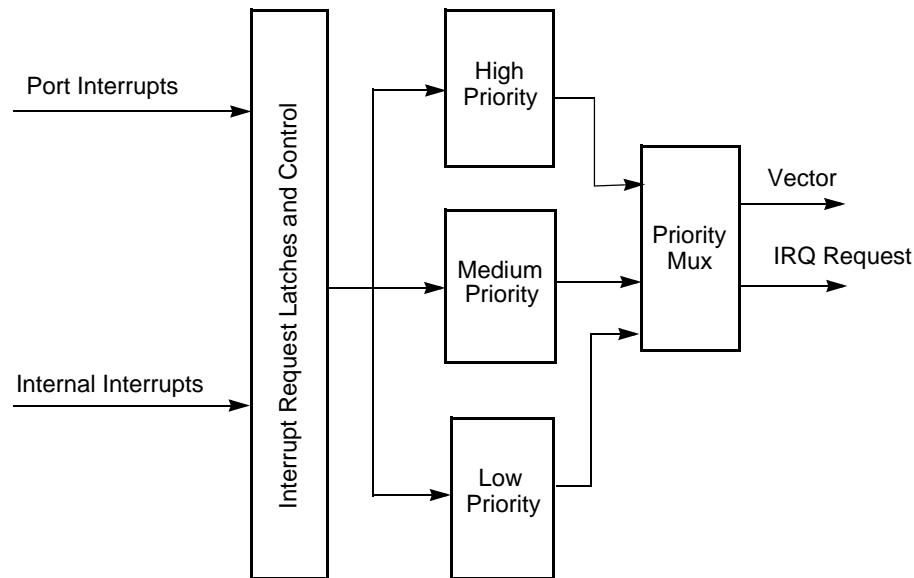

Figure 9. Interrupt Controller Block Diagram

Operation

Master Interrupt Enable

The master interrupt enable bit (IRQE) in the Interrupt Control register globally enables and disables interrupts.

Interrupts are globally enabled by any of the following actions:

- Execution of an EI (Enable Interrupt) instruction
- Execution of an IRET (Return from Interrupt) instruction
- Writing a 1 to the IRQE bit in the Interrupt Control register

Interrupts are globally disabled by any of the following actions:

- Execution of a DI (Disable Interrupt) instruction
- eZ8 CPU acknowledgement of an interrupt service request from the interrupt controller
- Writing a 0 to the IRQE bit in the Interrupt Control register
- Reset

- Execution of a Trap instruction
- Illegal Instruction trap

Interrupt Vectors and Priority

The interrupt controller supports three levels of interrupt priority. Level 3 is the highest priority, Level 2 is the second highest priority, and Level 1 is the lowest priority. If all of the interrupts were enabled with identical interrupt priority (all as Level 2 interrupts, for example), then interrupt priority would be assigned from highest to lowest as specified in Table 23. Level 3 interrupts always have higher priority than Level 2 interrupts which, in turn, always have higher priority than Level 1 interrupts. Within each interrupt priority level (Level 1, Level 2, or Level 3), priority is assigned as specified in Table 23. Reset, Watch-Dog Timer interrupt (if enabled), and Illegal Instruction Trap always have highest priority.

Interrupt Assertion

Interrupt sources assert their interrupt requests for only a single system clock period (single pulse). When the interrupt request is acknowledged by the eZ8 CPU, the corresponding bit in the Interrupt Request register is cleared until the next interrupt occurs. Writing a 0 to the corresponding bit in the Interrupt Request register likewise clears the interrupt request.



Caution:

The following style of coding to clear bits in the Interrupt Request registers is **NOT** recommended. All incoming interrupts that are received between execution of the first LDX command and the last LDX command are lost.

Poor coding style that can result in lost interrupt requests:

```
LDX r0, IRQ0  
AND r0, MASK  
LDX IRQ0, r0
```

To avoid missing interrupts, the following style of coding to clear bits in the Interrupt Request 0 register is recommended:

Good coding style that avoids lost interrupt requests:

```
ANDX IRQ0, MASK
```

Software Interrupt Assertion

Program code can generate interrupts directly. Writing a 1 to the desired bit in the Interrupt Request register triggers an interrupt (assuming that interrupt is enabled). When the interrupt request is acknowledged by the eZ8 CPU, the bit in the Interrupt Request register is automatically cleared to 0.



Caution:

The following style of coding to generate software interrupts by setting bits in the Interrupt Request registers is **NOT** recommended. All incoming interrupts that are received between execution of the first LDX command and the last LDX command are lost.

Poor coding style that can result in lost interrupt requests:

```
LDX r0, IRQ0
OR r0, MASK
LDX IRQ0, r0
```



Note:

To avoid missing interrupts, the following style of coding to set bits in the Interrupt Request registers is recommended:

Good coding style that avoids lost interrupt requests:

```
ORX IRQ0, MASK
```

Interrupt Control Register Definitions

For all interrupts other than the Watch-Dog Timer interrupt, the interrupt control registers enable individual interrupts, set interrupt priorities, and indicate interrupt requests.

Interrupt Request 0 Register

The Interrupt Request 0 (IRQ0) register (Table 24) stores the interrupt requests for both vectored and polled interrupts. When a request is presented to the interrupt controller, the corresponding bit in the IRQ0 register becomes 1. If interrupts are globally enabled (vectored interrupts), the interrupt controller passes an interrupt request to the eZ8 CPU. If interrupts are globally disabled (polled interrupts), the eZ8 CPU can read the Interrupt Request 0 register to determine if any interrupt requests are pending.

Table 24. Interrupt Request 0 Register (IRQ0)

BITS	7	6	5	4	3	2	1	0
FIELD	Reserved	TII	TOI	U0RXI	U0TXI	I2CI	SPII	ADCI
RESET	0	0	0	0	0	0	0	0
R/W	R/W	R/W	R/W	R/W	R/W	R/W	R/W	R/W
ADDR	FC0H							



Reserved—Must be 0.

T1I—Timer 1 Interrupt Request

0 = No interrupt request is pending for Timer 1.

1 = An interrupt request from Timer 1 is awaiting service.

T0I—Timer 0 Interrupt Request

0 = No interrupt request is pending for Timer 0.

1 = An interrupt request from Timer 0 is awaiting service.

U0RXI—UART 0 Receiver Interrupt Request

0 = No interrupt request is pending for the UART 0 receiver.

1 = An interrupt request from the UART 0 receiver is awaiting service.

U0TXI—UART 0 Transmitter Interrupt Request

0 = No interrupt request is pending for the UART 0 transmitter.

1 = An interrupt request from the UART 0 transmitter is awaiting service.

I²CI— I²C Interrupt Request

0 = No interrupt request is pending for the I²C.

1 = An interrupt request from the I²C is awaiting service.

SPII—SPI Interrupt Request

0 = No interrupt request is pending for the SPI.

1 = An interrupt request from the SPI is awaiting service.

ADCI—ADC Interrupt Request

0 = No interrupt request is pending for the Analog-to-Digital Converter.

1 = An interrupt request from the Analog-to-Digital Converter is awaiting service.

Interrupt Request 1 Register

The Interrupt Request 1 (IRQ1) register (Table 25) stores interrupt requests for both vectored and polled interrupts. When a request is presented to the interrupt controller, the corresponding bit in the IRQ1 register becomes 1. If interrupts are globally enabled (vectored interrupts), the interrupt controller passes an interrupt request to the eZ8 CPU. If interrupts are globally disabled (polled interrupts), the eZ8 CPU can read the Interrupt Request 1 register to determine if any interrupt requests are pending.



Table 25. Interrupt Request 1 Register (IRQ1)

BITS	7	6	5	4	3	2	1	0
FIELD	PA7I	PA6I	PA5I	PA4I	PA3I	PA2I	PA1I	PA0I
RESET	0	0	0	0	0	0	0	0
R/W	R/W	R/W	R/W	R/W	R/W	R/W	R/W	R/W
ADDR	FC3H							

PAxI—Port A Pin *x* Interrupt Request

0 = No interrupt request is pending for GPIO Port A pin *x*.

1 = An interrupt request from GPIO Port A pin *x* is awaiting service.

where *x* indicates the specific GPIO Port pin number (0 through 7).

Interrupt Request 2 Register

The Interrupt Request 2 (IRQ2) register (Table 26) stores interrupt requests for both vectored and polled interrupts. When a request is presented to the interrupt controller, the corresponding bit in the IRQ2 register becomes 1. If interrupts are globally enabled (vectored interrupts), the interrupt controller passes an interrupt request to the eZ8 CPU. If interrupts are globally disabled (polled interrupts), the eZ8 CPU can read the Interrupt Request 2 register to determine if any interrupt requests are pending.

Table 26. Interrupt Request 2 Register (IRQ2)

BITS	7	6	5	4	3	2	1	0
FIELD	Reserved				PC3I	PC2I	PC1I	PC0I
RESET	0	0	0	0	0	0	0	0
R/W	R/W	R/W	R/W	R/W	R/W	R/W	R/W	R/W
ADDR	FC6H							

Reserved—Must be 0.

PCxI—Port C Pin *x* Interrupt Request

0 = No interrupt request is pending for GPIO Port C pin *x*.

1 = An interrupt request from GPIO Port C pin *x* is awaiting service.

where *x* indicates the specific GPIO Port C pin number (0 through 3).



IRQ0 Enable High and Low Bit Registers

The IRQ0 Enable High and Low Bit registers (Tables 28 and Table 29) form a priority encoded enabling for interrupts in the Interrupt Request 0 register. Priority is generated by setting bits in each register. Table 27 describes the priority control for IRQ0.

Table 27. IRQ0 Enable and Priority Encoding

IRQ0ENH[x]	IRQ0ENL[x]	Priority	Description
0	0	Disabled	Disabled
0	1	Level 1	Low
1	0	Level 2	Nominal
1	1	Level 3	High

where *x* indicates the register bits from 0 through 7.

Table 28. IRQ0 Enable High Bit Register (IRQ0ENH)

BITS	7	6	5	4	3	2	1	0
FIELD	Reserved	T1ENH	T0ENH	U0RENH	U0TENH	I2CENH	SPIENH	ADCENH
RESET	0	0	0	0	0	0	0	0
R/W	R/W	R/W	R/W	R/W	R/W	R/W	R/W	R/W
ADDR	FC1H							

Reserved—Must be 0.

T1ENH—Timer 1 Interrupt Request Enable High Bit

T0ENH—Timer 0 Interrupt Request Enable High Bit

U0RENH—UART 0 Receive Interrupt Request Enable High Bit

U0TENH—UART 0 Transmit Interrupt Request Enable High Bit

I2CENH—I²C Interrupt Request Enable High Bit

SPIENH—SPI Interrupt Request Enable High Bit

ADCENH—ADC Interrupt Request Enable High Bit



Table 29. IRQ0 Enable Low Bit Register (IRQ0ENL)

BITS	7	6	5	4	3	2	1	0
FIELD	Reserved	T1ENL	T0ENL	U0RENL	U0TENL	I2CENL	SPIENL	ADCENL
RESET	0	0	0	0	0	0	0	0
R/W	R/W	R/W	R/W	R/W	R/W	R/W	R/W	R/W
ADDR	FC2H							

Reserved—Must be 0.

T1ENL—Timer 1 Interrupt Request Enable Low Bit

T0ENL—Timer 0 Interrupt Request Enable Low Bit

U0RENL—UART 0 Receive Interrupt Request Enable Low Bit

U0TENL—UART 0 Transmit Interrupt Request Enable Low Bit

I2CENL—I²C Interrupt Request Enable Low Bit

SPIENL—SPI Interrupt Request Enable Low Bit

ADCENL—ADC Interrupt Request Enable Low Bit

IRQ1 Enable High and Low Bit Registers

The IRQ1 Enable High and Low Bit registers (Tables 31 and Table 32) form a priority encoded enabling for interrupts in the Interrupt Request 1 register. Priority is generated by setting bits in each register. Table 30 describes the priority control for IRQ1.

Table 30. IRQ1 Enable and Priority Encoding

IRQ1ENH[x]	IRQ1ENL[x]	Priority	Description
0	0	Disabled	Disabled
0	1	Level 1	Low
1	0	Level 2	Nominal
1	1	Level 3	High

where *x* indicates the register bits from 0 through 7.



Table 31. IRQ1 Enable High Bit Register (IRQ1ENH)

BITS	7	6	5	4	3	2	1	0
FIELD	PA7ENH	PA6ENH	PA5ENH	PA4ENH	PA3ENH	PA2ENH	PA1ENH	PA0ENH
RESET	0	0	0	0	0	0	0	0
R/W	R/W	R/W	R/W	R/W	R/W	R/W	R/W	R/W
ADDR	FC4H							

PA_xENH—Port A Bit[*x*] Interrupt Request Enable High Bit

Table 32. IRQ1 Enable Low Bit Register (IRQ1ENL)

BITS	7	6	5	4	3	2	1	0
FIELD	PA7ENL	PA6ENL	PA5ENL	PA4ENL	PA3ENL	PA2ENL	PA1ENL	PA0ENL
RESET	0	0	0	0	0	0	0	0
R/W	R/W	R/W	R/W	R/W	R/W	R/W	R/W	R/W
ADDR	FC5H							

PA_xENL—Port A Bit[*x*] Interrupt Request Enable Low Bit

IRQ2 Enable High and Low Bit Registers

The IRQ2 Enable High and Low Bit registers (Tables 34 and Table 35) form a priority encoded enabling for interrupts in the Interrupt Request 2 register. Priority is generated by setting bits in each register. Table 33 describes the priority control for IRQ2.

Table 33. IRQ2 Enable and Priority Encoding

IRQ2ENH[<i>x</i>]	IRQ2ENL[<i>x</i>]	Priority	Description
0	0	Disabled	Disabled
0	1	Level 1	Low
1	0	Level 2	Nominal
1	1	Level 3	High

where *x* indicates the register bits from 0 through 7.



Table 34. IRQ2 Enable High Bit Register (IRQ2ENH)

BITS	7	6	5	4	3	2	1	0
FIELD	Reserved				C3ENH	C2ENH	C1ENH	C0ENH
RESET	0	0	0	0	0	0	0	0
R/W	R/W	R/W	R/W	R/W	R/W	R/W	R/W	R/W
ADDR	FC7H							

Reserved—Must be 0.

C3ENH—Port C3 Interrupt Request Enable High Bit

C2ENH—Port C2 Interrupt Request Enable High Bit

C1ENH—Port C1 Interrupt Request Enable High Bit

C0ENH—Port C0 Interrupt Request Enable High Bit

Table 35. IRQ2 Enable Low Bit Register (IRQ2ENL)

BITS	7	6	5	4	3	2	1	0
FIELD	Reserved				C3ENL	C2ENL	C1ENL	C0ENL
RESET	0	0	0	0	0	0	0	0
R/W	R/W	R/W	R/W	R/W	R/W	R/W	R/W	R/W
ADDR	FC8H							

Reserved—Must be 0.

C3ENL—Port C3 Interrupt Request Enable Low Bit

C2ENL—Port C2 Interrupt Request Enable Low Bit

C1ENL—Port C1 Interrupt Request Enable Low Bit

C0ENL—Port C0 Interrupt Request Enable Low Bit

Interrupt Edge Select Register

The Interrupt Edge Select (IRQES) register (Table 36) determines whether an interrupt is generated for the rising edge or falling edge on the selected GPIO Port input pin. The min-



imum pulse width must be greater than 1 system clock to guarantee capture of the edge triggered interrupt. Edge detection for pulses less than 1 system clock are not guaranteed.

Table 36. Interrupt Edge Select Register (IRQES)

BITS	7	6	5	4	3	2	1	0
FIELD	IES7	IES6	IES5	IES4	IES3	IES2	IES1	IES0
RESET	0	0	0	0	0	0	0	0
R/W	R/W	R/W	R/W	R/W	R/W	R/W	R/W	R/W
ADDR	FCDH							

IES_x—Interrupt Edge Select *x*

0 = An interrupt request is generated on the falling edge of the PAX input.

1 = An interrupt request is generated on the rising edge of the PAX input.

where *x* indicates the specific GPIO Port pin number (0 through 7).

Interrupt Control Register

The Interrupt Control (IRQCTL) register (Table 37) contains the master enable bit for all interrupts.

Table 37. Interrupt Control Register (IRQCTL)

BITS	7	6	5	4	3	2	1	0
FIELD	IRQE	Reserved						
RESET	0	0	0	0	0	0	0	0
R/W	R/W	R	R	R	R	R	R	R
ADDR	FCFH							

IRQE—Interrupt Request Enable

This bit is set to 1 by execution of an EI (Enable Interrupts) or IRET (Interrupt Return) instruction, or by a direct register write of a 1 to this bit. It is reset to 0 by executing a DI instruction, eZ8 CPU acknowledgement of an interrupt request, Reset or by a direct register write of a 0 to this bit.

0 = Interrupts are disabled.

1 = Interrupts are enabled.

Reserved—Must be 0.



Timers

Overview

These Z8F082x family products contain up to two 16-bit reloadable timers that can be used for timing, event counting, or generation of pulse-width modulated (PWM) signals. The timers' features include:

- 16-bit reload counter
- Programmable prescaler with prescale values from 1 to 128
- PWM output generation
- Capture and compare capability
- External input pin for timer input, clock gating, or capture signal. External input pin signal frequency is limited to a maximum of one-fourth the system clock frequency.
- Timer output pin
- Timer interrupt

In addition to the timers described in this chapter, the Baud Rate Generators for any unused UART, SPI, or I²C peripherals may also be used to provide basic timing functionality. Refer to the respective serial communication peripheral chapters for information on using the Baud Rate Generators as timers.

Architecture

Figure 10 illustrates the architecture of the timers.

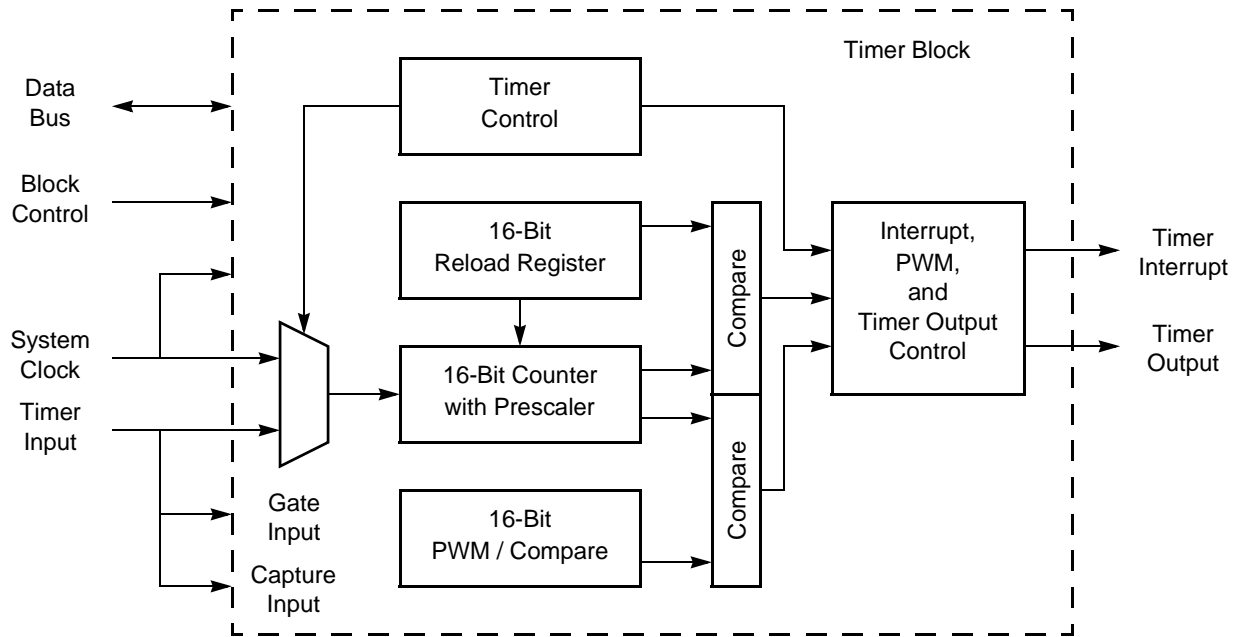

Figure 10. Timer Block Diagram

Operation

The timers are 16-bit up-counters. Minimum time-out delay is set by loading the value 0001H into the Timer Reload High and Low Byte registers and setting the prescale value to 1. Maximum time-out delay is set by loading the value 0000H into the Timer Reload High and Low Byte registers and setting the prescale value to 128. If the Timer reaches FFFFH, the timer rolls over to 0000H and continues counting.

Timer Operating Modes

The timers can be configured to operate in the following modes:

ONE-SHOT Mode

In ONE-SHOT mode, the timer counts up to the 16-bit Reload value stored in the Timer Reload High and Low Byte registers. The timer input is the system clock. Upon reaching the Reload value, the timer generates an interrupt and the count value in the Timer High and Low Byte registers is reset to 0001H. Then, the timer is automatically disabled and stops counting.

Also, if the Timer Output alternate function is enabled, the Timer Output pin changes state for one system clock cycle (from Low to High or from High to Low) upon timer Reload. If



it is desired to have the Timer Output make a permanent state change upon One-Shot time-out, first set the TPOL bit in the Timer Control Register to the start value before beginning ONE-SHOT mode. Then, after starting the timer, set TPOL to the opposite bit value.

The steps for configuring a timer for ONE-SHOT mode and initiating the count are as follows:

1. Write to the Timer Control register to:
 - Disable the timer
 - Configure the timer for ONE-SHOT mode.
 - Set the prescale value.
 - If using the Timer Output alternate function, set the initial output level (High or Low).
2. Write to the Timer High and Low Byte registers to set the starting count value.
3. Write to the Timer Reload High and Low Byte registers to set the Reload value.
4. If desired, enable the timer interrupt and set the timer interrupt priority by writing to the relevant interrupt registers.
5. If using the Timer Output function, configure the associated GPIO port pin for the Timer Output alternate function.
6. Write to the Timer Control register to enable the timer and initiate counting.

In ONE-SHOT mode, the system clock always provides the timer input. The timer period is given by the following equation:

$$\text{ONE-SHOT Mode Time-Out Period (s)} = \frac{(\text{Reload Value} - \text{Start Value}) \times \text{Prescale}}{\text{System Clock Frequency (Hz)}}$$

CONTINUOUS Mode

In CONTINUOUS mode, the timer counts up to the 16-bit Reload value stored in the Timer Reload High and Low Byte registers. The timer input is the system clock. Upon reaching the Reload value, the timer generates an interrupt, the count value in the Timer High and Low Byte registers is reset to 0001H and counting resumes. Also, if the Timer Output alternate function is enabled, the Timer Output pin changes state (from Low to High or from High to Low) upon timer Reload.

The steps for configuring a timer for CONTINUOUS mode and initiating the count are as follows:

1. Write to the Timer Control register to:
 - Disable the timer
 - Configure the timer for CONTINUOUS mode.
 - Set the prescale value.

- If using the Timer Output alternate function, set the initial output level (High or Low).
- 2. Write to the Timer High and Low Byte registers to set the starting count value (usually 0001H). This only affects the first pass in CONTINUOUS mode. After the first timer Reload in CONTINUOUS mode, counting always begins at the reset value of 0001H.
- 3. Write to the Timer Reload High and Low Byte registers to set the Reload value.
- 4. If desired, enable the timer interrupt and set the timer interrupt priority by writing to the relevant interrupt registers.
- 5. If using the Timer Output function, configure the associated GPIO port pin for the Timer Output alternate function.
- 6. Write to the Timer Control register to enable the timer and initiate counting.

In CONTINUOUS mode, the system clock always provides the timer input. The timer period is given by the following equation:

$$\text{CONTINUOUS Mode Time-Out Period (s)} = \frac{\text{Reload Value} \times \text{Prescale}}{\text{System Clock Frequency (Hz)}}$$

If an initial starting value other than 0001H is loaded into the Timer High and Low Byte registers, the ONE-SHOT mode equation must be used to determine the first time-out period.

COUNTER Mode

In COUNTER mode, the timer counts input transitions from a GPIO port pin. The timer input is taken from the GPIO Port pin Timer Input alternate function. The TPOL bit in the Timer Control Register selects whether the count occurs on the rising edge or the falling edge of the Timer Input signal. In COUNTER mode, the prescaler is disabled.



Caution: The input frequency of the Timer Input signal must not exceed one-fourth the system clock frequency.

Upon reaching the Reload value stored in the Timer Reload High and Low Byte registers, the timer generates an interrupt, the count value in the Timer High and Low Byte registers is reset to 0001H and counting resumes. Also, if the Timer Output alternate function is enabled, the Timer Output pin changes state (from Low to High or from High to Low) at timer Reload.

The steps for configuring a timer for COUNTER mode and initiating the count are as follows:

1. Write to the Timer Control register to:
 - Disable the timer
 - Configure the timer for COUNTER mode.



- Select either the rising edge or falling edge of the Timer Input signal for the count. This also sets the initial logic level (High or Low) for the Timer Output alternate function. However, the Timer Output function does not have to be enabled.
- 2. Write to the Timer High and Low Byte registers to set the starting count value. This only affects the first pass in COUNTER mode. After the first timer Reload in COUNTER mode, counting always begins at the reset value of 0001H. Generally, in COUNTER mode the Timer High and Low Byte registers must be written with the value 0001H.
- 3. Write to the Timer Reload High and Low Byte registers to set the Reload value.
- 4. If desired, enable the timer interrupt and set the timer interrupt priority by writing to the relevant interrupt registers.
- 5. Configure the associated GPIO port pin for the Timer Input alternate function.
- 6. If using the Timer Output function, configure the associated GPIO port pin for the Timer Output alternate function.
- 7. Write to the Timer Control register to enable the timer.

In COUNTER mode, the number of Timer Input transitions since the timer start is given by the following equation:

$$\text{COUNTER Mode Timer Input Transitions} = \text{Current Count Value} - \text{Start Value}$$

PWM Mode

In PWM mode, the timer outputs a Pulse-Width Modulator (PWM) output signal through a GPIO Port pin. The timer input is the system clock. The timer first counts up to the 16-bit PWM match value stored in the Timer PWM High and Low Byte registers. When the timer count value matches the PWM value, the Timer Output toggles. The timer continues counting until it reaches the Reload value stored in the Timer Reload High and Low Byte registers. Upon reaching the Reload value, the timer generates an interrupt, the count value in the Timer High and Low Byte registers is reset to 0001H and counting resumes.

If the TPOL bit in the Timer Control register is set to 1, the Timer Output signal begins as a High (1) and then transitions to a Low (0) when the timer value matches the PWM value. The Timer Output signal returns to a High (1) after the timer reaches the Reload value and is reset to 0001H.

If the TPOL bit in the Timer Control register is set to 0, the Timer Output signal begins as a Low (0) and then transitions to a High (1) when the timer value matches the PWM value. The Timer Output signal returns to a Low (0) after the timer reaches the Reload value and is reset to 0001H.

The steps for configuring a timer for PWM mode and initiating the PWM operation are as follows:



1. Write to the Timer Control register to:
 - Disable the timer
 - Configure the timer for PWM mode.
 - Set the prescale value.
 - Set the initial logic level (High or Low) and PWM High/Low transition for the Timer Output alternate function.
2. Write to the Timer High and Low Byte registers to set the starting count value (typically 0001H). This only affects the first pass in PWM mode. After the first timer reset in PWM mode, counting always begins at the reset value of 0001H.
3. Write to the PWM High and Low Byte registers to set the PWM value.
4. Write to the Timer Reload High and Low Byte registers to set the Reload value (PWM period). The Reload value must be greater than the PWM value.
5. If desired, enable the timer interrupt and set the timer interrupt priority by writing to the relevant interrupt registers.
6. Configure the associated GPIO port pin for the Timer Output alternate function.
7. Write to the Timer Control register to enable the timer and initiate counting.

The PWM period is given by the following equation:

$$\text{PWM Period (s)} = \frac{\text{Reload Value} \times \text{Prescale}}{\text{System Clock Frequency (Hz)}}$$

If an initial starting value other than 0001H is loaded into the Timer High and Low Byte registers, the One-Shot mode equation must be used to determine the first PWM time-out period.

If TPOL is set to 0, the ratio of the PWM output High time to the total period is given by:

$$\text{PWM Output High Time Ratio (\%)} = \frac{\text{Reload Value} - \text{PWM Value}}{\text{Reload Value}} \times 100$$

If TPOL is set to 1, the ratio of the PWM output High time to the total period is given by:

$$\text{PWM Output High Time Ratio (\%)} = \frac{\text{PWM Value}}{\text{Reload Value}} \times 100$$

CAPTURE Mode

In CAPTURE mode, the current timer count value is recorded when the desired external Timer Input transition occurs. The Capture count value is written to the Timer PWM High and Low Byte Registers. The timer input is the system clock. The TPOL bit in the Timer Control register determines if the Capture occurs on a rising edge or a falling edge of the



Timer Input signal. When the Capture event occurs, an interrupt is generated and the timer continues counting.

The timer continues counting up to the 16-bit Reload value stored in the Timer Reload High and Low Byte registers. Upon reaching the Reload value, the timer generates an interrupt and continues counting.

The steps for configuring a timer for CAPTURE mode and initiating the count are as follows:

1. Write to the Timer Control register to:
 - Disable the timer
 - Configure the timer for CAPTURE mode.
 - Set the prescale value.
 - Set the Capture edge (rising or falling) for the Timer Input.
2. Write to the Timer High and Low Byte registers to set the starting count value (typically 0001H).
3. Write to the Timer Reload High and Low Byte registers to set the Reload value.
4. Clear the Timer PWM High and Low Byte registers to 0000H. This allows user software to determine if interrupts were generated by either a capture event or a reload. If the PWM High and Low Byte registers still contain 0000H after the interrupt, then the interrupt was generated by a Reload.
5. If desired, enable the timer interrupt and set the timer interrupt priority by writing to the relevant interrupt registers.
6. Configure the associated GPIO port pin for the Timer Input alternate function.
7. Write to the Timer Control register to enable the timer and initiate counting.

In CAPTURE mode, the elapsed time from timer start to Capture event can be calculated using the following equation:

$$\text{Capture Elapsed Time (s)} = \frac{(\text{Capture Value} - \text{Start Value}) \times \text{Prescale}}{\text{System Clock Frequency (Hz)}}$$

COMPARE Mode

In COMPARE mode, the timer counts up to the 16-bit maximum Compare value stored in the Timer Reload High and Low Byte registers. The timer input is the system clock. Upon reaching the Compare value, the timer generates an interrupt and counting continues (the timer value is not reset to 0001H). Also, if the Timer Output alternate function is enabled, the Timer Output pin changes state (from Low to High or from High to Low) upon Compare.



If the Timer reaches FFFFH, the timer rolls over to 0000H and continue counting.

The steps for configuring a timer for COMPARE mode and initiating the count are as follows:

1. Write to the Timer Control register to:
 - Disable the timer
 - Configure the timer for COMPARE mode.
 - Set the prescale value.
 - Set the initial logic level (High or Low) for the Timer Output alternate function, if desired.
2. Write to the Timer High and Low Byte registers to set the starting count value.
3. Write to the Timer Reload High and Low Byte registers to set the Compare value.
4. If desired, enable the timer interrupt and set the timer interrupt priority by writing to the relevant interrupt registers.
5. If using the Timer Output function, configure the associated GPIO port pin for the Timer Output alternate function.
6. Write to the Timer Control register to enable the timer and initiate counting.

In COMPARE mode, the system clock always provides the timer input. The Compare time is given by the following equation:

$$\text{Compare Mode Time (s)} = \frac{(\text{Compare Value} - \text{Start Value}) \times \text{Prescale}}{\text{System Clock Frequency (Hz)}}$$

GATED Mode

In GATED mode, the timer counts only when the Timer Input signal is in its active state (asserted), as determined by the TPOL bit in the Timer Control register. When the Timer Input signal is asserted, counting begins. A timer interrupt is generated when the Timer Input signal is deasserted or a timer reload occurs. To determine if a Timer Input signal deassertion generated the interrupt, read the associated GPIO input value and compare to the value stored in the TPOL bit.

The timer counts up to the 16-bit Reload value stored in the Timer Reload High and Low Byte registers. The timer input is the system clock. When reaching the Reload value, the timer generates an interrupt, the count value in the Timer High and Low Byte registers is reset to 0001H and counting resumes (assuming the Timer Input signal is still asserted). Also, if the Timer Output alternate function is enabled, the Timer Output pin changes state (from Low to High or from High to Low) at timer reset.

The steps for configuring a timer for GATED mode and initiating the count are as follows:

1. Write to the Timer Control register to:
 - Disable the timer



- Configure the timer for GATED mode.
 - Set the prescale value.
2. Write to the Timer High and Low Byte registers to set the starting count value. This only affects the first pass in GATED mode. After the first timer reset in GATED mode, counting always begins at the reset value of 0001H.
 3. Write to the Timer Reload High and Low Byte registers to set the Reload value.
 4. If desired, enable the timer interrupt and set the timer interrupt priority by writing to the relevant interrupt registers.
 5. Configure the associated GPIO port pin for the Timer Input alternate function.
 6. Write to the Timer Control register to enable the timer.
 7. Assert the Timer Input signal to initiate the counting.

CAPTURE/COMPARE Mode

In CAPTURE/COMPARE mode, the timer begins counting on the *first* external Timer Input transition. The desired transition (rising edge or falling edge) is set by the TPOL bit in the Timer Control Register. The timer input is the system clock.

Every subsequent desired transition (after the first) of the Timer Input signal captures the current count value. The Capture value is written to the Timer PWM High and Low Byte Registers. When the Capture event occurs, an interrupt is generated, the count value in the Timer High and Low Byte registers is reset to 0001H, and counting resumes.

If no Capture event occurs, the timer counts up to the 16-bit Compare value stored in the Timer Reload High and Low Byte registers. Upon reaching the Compare value, the timer generates an interrupt, the count value in the Timer High and Low Byte registers is reset to 0001H and counting resumes.

The steps for configuring a timer for CAPTURE/COMPARE mode and initiating the count are as follows:

1. Write to the Timer Control register to:
 - Disable the timer
 - Configure the timer for CAPTURE/COMPARE mode.
 - Set the prescale value.
 - Set the Capture edge (rising or falling) for the Timer Input.
2. Write to the Timer High and Low Byte registers to set the starting count value (typically 0001H).
3. Write to the Timer Reload High and Low Byte registers to set the Compare value.
4. If desired, enable the timer interrupt and set the timer interrupt priority by writing to the relevant interrupt registers.



5. Configure the associated GPIO port pin for the Timer Input alternate function.
6. Write to the Timer Control register to enable the timer.
7. Counting begins on the first appropriate transition of the Timer Input signal. No interrupt is generated by this first edge.

In CAPTURE/COMPARE mode, the elapsed time from timer start to Capture event can be calculated using the following equation:

$$\text{Capture Elapsed Time (s)} = \frac{(\text{Capture Value} - \text{Start Value}) \times \text{Prescale}}{\text{System Clock Frequency (Hz)}}$$

Reading the Timer Count Values

The current count value in the timers can be read while counting (enabled). This capability has no effect on timer operation. When the timer is enabled and the Timer High Byte register is read, the contents of the Timer Low Byte register are placed in a holding register. A subsequent read from the Timer Low Byte register returns the value in the holding register. This operation allows accurate reads of the full 16-bit timer count value while enabled. When the timers are not enabled, a read from the Timer Low Byte register returns the actual value in the counter.

Timer Output Signal Operation

Timer Output is a GPIO Port pin alternate function. Generally, the Timer Output is toggled every time the counter is reloaded.

Timer Control Register Definitions

Timer 0-1 High and Low Byte Registers

The Timer 0-1 High and Low Byte (TxH and TxL) registers (Tables 38 and 39) contain the current 16-bit timer count value. When the timer is enabled, a read from TxH causes the value in TxL to be stored in a temporary holding register. A read from TMRL always returns this temporary register when the timers are enabled. When the timer is disabled, reads from the TMRL reads the register directly.

Writing to the Timer High and Low Byte registers while the timer is enabled is not recommended. There are no temporary holding registers available for write operations, so simultaneous 16-bit writes are not possible. If either the Timer High or Low Byte registers are



written during counting, the 8-bit written value is placed in the counter (High or Low Byte) at the next clock edge. The counter continues counting from the new value.

Table 38. Timer 0-1 High Byte Register (TxH)

BITS	7	6	5	4	3	2	1	0
FIELD	TH							
RESET	0	0	0	0	0	0	0	0
R/W	R/W	R/W	R/W	R/W	R/W	R/W	R/W	R/W
ADDR	F00H, F08H							

Table 39. Timer 0-1 Low Byte Register (TxL)

BITS	7	6	5	4	3	2	1	0
FIELD	TL							
RESET	0	0	0	0	0	0	0	1
R/W	R/W	R/W	R/W	R/W	R/W	R/W	R/W	R/W
ADDR	F01H, F09H							

TH and TL—Timer High and Low Bytes

These 2 bytes, {TMRH[7:0], TMRL[7:0]}, contain the current 16-bit timer count value.

Timer Reload High and Low Byte Registers

The Timer 0-1 Reload High and Low Byte (TxRH and TxRL) registers (Tables 40 and 41) store a 16-bit reload value, {TRH[7:0], TRL[7:0]}. Values written to the Timer Reload High Byte register are stored in a temporary holding register. When a write to the Timer Reload Low Byte register occurs, the temporary holding register value is written to the Timer High Byte register. This operation allows simultaneous updates of the 16-bit Timer Reload value.



In COMPARE mode, the Timer Reload High and Low Byte registers store the 16-bit Compare value.

Table 40. Timer 0-1 Reload High Byte Register (TxRH)

BITS	7	6	5	4	3	2	1	0
FIELD	TRH							
RESET	1	1	1	1	1	1	1	1
R/W	R/W	R/W	R/W	R/W	R/W	R/W	R/W	R/W
ADDR	F02H, F0AH							

Table 41. Timer 0-1 Reload Low Byte Register (TxRL)

BITS	7	6	5	4	3	2	1	0
FIELD	TRL							
RESET	1	1	1	1	1	1	1	1
R/W	R/W	R/W	R/W	R/W	R/W	R/W	R/W	R/W
ADDR	F03H, F0BH							

TRH and TRL—Timer Reload Register High and Low

These two bytes form the 16-bit Reload value, {TRH[7:0], TRL[7:0]}. This value sets the maximum count value which initiates a timer reload to 0001H. In COMPARE mode, these two bytes form the 16-bit Compare value.



Timer 0-1 PWM High and Low Byte Registers

The Timer 0-1 PWM High and Low Byte (TxPWMH and TxPWML) registers (Tables 42 and 43) are used for Pulse-Width Modulator (PWM) operations. These registers also store the Capture values for the CAPTURE and CAPTURE/COMPARE modes.

Table 42. Timer 0-1 PWM High Byte Register (TxPWMH)

BITS	7	6	5	4	3	2	1	0
FIELD	PWMH							
RESET	0	0	0	0	0	0	0	0
R/W	R/W	R/W	R/W	R/W	R/W	R/W	R/W	R/W
ADDR	F04H, F0CH							

Table 43. Timer 0-1 PWM Low Byte Register (TxPWML)

BITS	7	6	5	4	3	2	1	0
FIELD	PWML							
RESET	0	0	0	0	0	0	0	0
R/W	R/W	R/W	R/W	R/W	R/W	R/W	R/W	R/W
ADDR	F05H, F0DH							

PWMH and PWML—Pulse-Width Modulator High and Low Bytes

These two bytes, {PWMH[7:0], PWML[7:0]}, form a 16-bit value that is compared to the current 16-bit timer count. When a match occurs, the PWM output changes state. The PWM output value is set by the TPOL bit in the Timer Control Register (TxCTL) register.

The TxPWMH and TxPWML registers also store the 16-bit captured timer value when operating in CAPTURE or CAPTURE/COMPARE modes.



Timer 0-3 Control 0 Registers

The Timer 0-3 Control 0 (TxCTL0) registers (Tables 44 and 45) allow cascading of the Timers.

Table 44. Timer 0-3 Control 0 Register (TxCTL0)

BITS	7	6	5	4	3	2	1	0
FIELD	Reserved			CSC	Reserved			
RESET	0	0	0	0	0	0	0	0
R/W	R/W	R/W	R/W	R/W	R/W	R/W	R/W	R/W
ADDR	F06H, F0EH, F16H, F1EH							

CSC—Cascade Timers

0 = Timer Input signal comes from the pin.

1 = For Timer 0, input signal is connected to Timer 1 output.

For Timer 1, input signal is connected to Timer 0 output.

Timer 0-1 Control 1 Registers

The Timer 0-1 Control (TxCTL) registers enable/disable the timers, set the prescaler value, and determine the timer operating mode.

Table 45. Timer 0-1 Control Register (TxCTL)

BITS	7	6	5	4	3	2	1	0
FIELD	TEN	TPOL	PRES			TMODE		
RESET	0	0	0	0	0	0	0	0
R/W	R/W	R/W	R/W	R/W	R/W	R/W	R/W	R/W
ADDR	F07H, F0FH							

TEN—Timer Enable

0 = Timer is disabled.

1 = Timer enabled to count.

TPOL—Timer Input/Output Polarity

Operation of this bit is a function of the current operating mode of the timer.

ONE-SHOT mode

When the timer is disabled, the Timer Output signal is set to the value of this bit.



When the timer is enabled, the Timer Output signal is complemented upon timer Reload.

CONTINUOUS mode

When the timer is disabled, the Timer Output signal is set to the value of this bit. When the timer is enabled, the Timer Output signal is complemented upon timer Reload.

COUNTER mode

When the timer is disabled, the Timer Output signal is set to the value of this bit. When the timer is enabled, the Timer Output signal is complemented upon timer Reload.

PWM mode

0 = Timer Output is forced Low (0) when the timer is disabled. When enabled, the Timer Output is forced High (1) upon PWM count match and forced Low (0) upon Reload.

1 = Timer Output is forced High (1) when the timer is disabled. When enabled, the Timer Output is forced Low (0) upon PWM count match and forced High (1) upon Reload.

CAPTURE mode

0 = Count is captured on the rising edge of the Timer Input signal.
1 = Count is captured on the falling edge of the Timer Input signal.

COMPARE mode

When the timer is disabled, the Timer Output signal is set to the value of this bit. When the timer is enabled, the Timer Output signal is complemented upon timer Reload.

GATED mode

0 = Timer counts when the Timer Input signal is High (1) and interrupts are generated on the falling edge of the Timer Input.
1 = Timer counts when the Timer Input signal is Low (0) and interrupts are generated on the rising edge of the Timer Input.

CAPTURE/COMPARE mode

0 = Counting is started on the first rising edge of the Timer Input signal. The current count is captured on subsequent rising edges of the Timer Input signal.
1 = Counting is started on the first falling edge of the Timer Input signal. The current count is captured on subsequent falling edges of the Timer Input signal.

PRES—Prescale value.

The timer input clock is divided by 2^{PRES} , where PRES can be set from 0 to 7. The prescaler is reset each time the Timer is disabled. This insures proper clock division



each time the Timer is restarted.

- 000 = Divide by 1
- 001 = Divide by 2
- 010 = Divide by 4
- 011 = Divide by 8
- 100 = Divide by 16
- 101 = Divide by 32
- 110 = Divide by 64
- 111 = Divide by 128

TMODE—Timer mode

- 000 = ONE-SHOT mode
- 001 = CONTINUOUS mode
- 010 = COUNTER mode
- 011 = PWM mode
- 100 = CAPTURE mode
- 101 = COMPARE mode
- 110 = GATED mode
- 111 = CAPTURE/COMPARE mode



Watch-Dog Timer

Overview

The Watch-Dog Timer (WDT) helps protect against corrupt or unreliable software, power faults, and other system-level problems which may place the Z8F082x family device into unsuitable operating states. The Watch-Dog Timer includes the following features:

- On-chip RC oscillator
- A selectable time-out response: Reset or interrupt
- 24-bit programmable time-out value

Operation

The Watch-Dog Timer (WDT) is a retriggerable one-shot timer that resets or interrupts the Z8F082x family device when the WDT reaches its terminal count. The Watch-Dog Timer uses its own dedicated on-chip RC oscillator as its clock source. The Watch-Dog Timer has only two modes of operation—on and off. Once enabled, it always counts and must be refreshed to prevent a time-out. An enable can be performed by executing the WDT instruction or by setting the WDT_AO Option Bit. The WDT_AO bit enables the Watch-Dog Timer to operate all the time, even if a WDT instruction has not been executed.

The Watch-Dog Timer is a 24-bit reloadable downcounter that uses three 8-bit registers in the eZ8 CPU register space to set the reload value. The nominal WDT time-out period is given by the following equation:

$$\text{WDT Time-out Period (ms)} = \frac{\text{WDT Reload Value}}{10}$$

where the WDT reload value is the decimal value of the 24-bit value given by {WDTU[7:0], WDTH[7:0], WDTL[7:0]} and the typical Watch-Dog Timer RC oscillator frequency is 10kHz. The Watch-Dog Timer cannot be refreshed once it reaches 000002H. The WDT Reload Value must not be set to values below 000004H. Table 45 provides

information on approximate time-out delays for the minimum and maximum WDT reload values.

Table 45. Watch-Dog Timer Approximate Time-Out Delays

WDT Reload Value (Hex)	WDT Reload Value (Decimal)	Approximate Time-Out Delay (with 10kHz typical WDT oscillator frequency)	
		Typical	Description
000004	4	400µs	Minimum time-out delay
FFFFFF	16,777,215	1677.5s	Maximum time-out delay

Watch-Dog Timer Refresh

When first enabled, the Watch-Dog Timer is loaded with the value in the Watch-Dog Timer Reload registers. The Watch-Dog Timer then counts down to 000000H unless a WDT instruction is executed by the eZ8 CPU. Execution of the WDT instruction causes the downcounter to be reloaded with the WDT Reload value stored in the Watch-Dog Timer Reload registers. Counting resumes following the reload operation.

When the Z8F082x family device is operating in DEBUG Mode (using the On-Chip Debugger), the Watch-Dog Timer is continuously refreshed to prevent spurious Watch-Dog Timer time-outs.

Watch-Dog Timer Time-Out Response

The Watch-Dog Timer times out when the counter reaches 000000H. A time-out of the Watch-Dog Timer generates either an interrupt or a Reset. The WDT_RES Option Bit determines the time-out response of the Watch-Dog Timer. Refer to the **Option Bits** chapter for information regarding programming of the WDT_RES Option Bit.

WDT Interrupt in Normal Operation

If configured to generate an interrupt when a time-out occurs, the Watch-Dog Timer issues an interrupt request to the interrupt controller and sets the WDT status bit in the Watch-Dog Timer Control register. If interrupts are enabled, the eZ8 CPU responds to the interrupt request by fetching the Watch-Dog Timer interrupt vector and executing code from the vector address. After time-out and interrupt generation, the Watch-Dog Timer counter rolls over to its maximum value of FFFFFH and continues counting. The Watch-Dog Timer counter is not automatically returned to its Reload Value.

WDT Reset in Stop Mode

If enabled in STOP mode and configured to generate a Reset when a time-out occurs and the device is in STOP mode, the Watch-Dog Timer initiates a STOP Mode Recovery. Both the WDT status bit and the STOP bit in the Watch-Dog Timer Control register are set to 1 following WDT time-out in STOP mode. Refer to the **Reset and STOP Mode Recovery**



chapter for more information. Default operation is for the WDT and its RC oscillator to be enabled during STOP mode.

To minimize power consumption in Stop Mode, the WDT and its RC oscillator can be disabled in STOP mode. The following sequence configures the WDT to be disabled when the Z8F082x family device enters Stop Mode following execution of a Stop instruction:

1. Write 55H to the Watch-Dog Timer Control register (WDTCTL).
2. Write AAH to the Watch-Dog Timer Control register (WDTCTL).
3. Write 81H to the Watch-Dog Timer Control register (WDTCTL) to configure the WDT and its oscillator to be disabled during Stop Mode. Alternatively, write 00H to the Watch-Dog Timer Control register (WDTCTL) as the third step in this sequence to reconfigure the WDT and its oscillator to be enabled during Stop Mode.

This sequence only affects WDT operation in STOP mode.

WDT Reset in Normal Operation

If configured to generate a Reset when a time-out occurs, the Watch-Dog Timer forces the device into the Reset state. The WDT status bit in the Watch-Dog Timer Control register is set to 1. Refer to the **Reset and STOP Mode Recovery** chapter for more information on Reset.

WDT Reset in STOP Mode

If enabled in STOP mode and configured to generate a Reset when a time-out occurs and the device is in STOP mode, the Watch-Dog Timer initiates a STOP Mode Recovery. Both the WDT status bit and the STOP bit in the Watch-Dog Timer Control register are set to 1 following WDT time-out in STOP mode. Refer to the **Reset and STOP Mode Recovery** chapter for more information. Default operation is for the WDT and its RC oscillator to be enabled during STOP mode.

To minimize power consumption in Stop Mode, the WDT and its RC oscillator can be disabled in STOP mode. The following sequence configures the WDT to be disabled when the Z8F082x family device enters Stop Mode following execution of a Stop instruction:

1. Write 55H to the Watch-Dog Timer Control register (WDTCTL).
2. Write AAH to the Watch-Dog Timer Control register (WDTCTL).
3. Write 81H to the Watch-Dog Timer Control register (WDTCTL) to configure the WDT and its oscillator to be disabled during Stop Mode. Alternatively, write 00H to the Watch-Dog Timer Control register (WDTCTL) as the third step in this sequence to reconfigure the WDT and its oscillator to be enabled during Stop Mode.

This sequence only affects WDT operation in STOP mode.



Watch-Dog Timer Reload Unlock Sequence

Writing the unlock sequence to the Watch-Dog Timer (WDTCTL) Control register address unlocks the three Watch-Dog Timer Reload Byte registers (WDTU, WDTH, and WDTL) to allow changes to the time-out period. These write operations to the WDTCTL register address produce no effect on the bits in the WDTCTL register. The locking mechanism prevents spurious writes to the Reload registers. The follow sequence is required to unlock the Watch-Dog Timer Reload Byte registers (WDTU, WDTH, and WDTL) for write access.

1. Write 55H to the Watch-Dog Timer Control register (WDTCTL).
2. Write AAH to the Watch-Dog Timer Control register (WDTCTL).
3. Write the Watch-Dog Timer Reload Upper Byte register (WDTU).
4. Write the Watch-Dog Timer Reload High Byte register (WDTH).
5. Write the Watch-Dog Timer Reload Low Byte register (WDTL).

All three Watch-Dog Timer Reload registers must be written in the order just listed. There must be no other register writes between each of these operations. If a register write occurs, the lock state machine resets and no further writes can occur, unless the sequence is restarted. The value in the Watch-Dog Timer Reload registers is loaded into the counter when the Watch-Dog Timer is first enabled and every time a WDT instruction is executed.

Watch-Dog Timer Control Register Definitions

Watch-Dog Timer Control Register

The Watch-Dog Timer Control (WDTCTL) register, detailed in Table 46, is a Read-Only register that indicates the source of the most recent Reset event, indicates a STOP Mode Recovery event, and indicates a Watch-Dog Timer time-out. Reading this register resets the upper four bits to 0.

Writing the 55H, AAH unlock sequence to the Watch-Dog Timer Control (WDTCTL) register address unlocks the three Watch-Dog Timer Reload Byte registers (WDTU, WDTH, and WDTL) to allow changes to the time-out period. These write operations to the



WDTCTL register address produce no effect on the bits in the WDTCTL register. The locking mechanism prevents spurious writes to the Reload registers.

Table 46. Watch-Dog Timer Control Register (WDTCTL)

BITS	7	6	5	4	3	2	1	0
FIELD	POR	STOP	WDT	EXT	Reserved			
RESET	See descriptions below			0	0	0	0	0
R/W	R	R	R	R	R	R	R	R
ADDR	FF0H							

Reset or STOP Mode Recovery Event	POR	STOP	WDT	EXT
Power-On Reset	1	0	0	0
Reset via $\overline{\text{RESET}}$ pin assertion	0	0	0	1
Reset via Watch-Dog Timer time-out	0	0	1	0
Reset via the On-Chip Debugger (OCTCTL[1] set to 1)	1	0	0	0
Reset from STOP Mode through the DBG Pin driven Low	1	0	0	0
STOP Mode Recovery via GPIO pin transition	0	1	0	0
STOP Mode Recovery via Watch-Dog Timer time-out	0	1	1	0

POR—Power-On Reset Indicator

If this bit is set to 1, a Power-On Reset event occurred. This bit is reset to 0 if a WDT time-out or STOP Mode Recovery occurs. This bit is also reset to 0 when the register is read.

STOP—STOP Mode Recovery Indicator

If this bit is set to 1, a STOP Mode Recovery occurred. If the STOP and WDT bits are both set to 1, the STOP Mode Recovery occurred due to a WDT time-out. If the STOP bit is 1 and the WDT bit is 0, the STOP Mode Recovery was not caused by a WDT time-out. This bit is reset by a Power-On Reset or a WDT time-out that occurred while not in STOP mode. Reading this register also resets this bit.

WDT—Watch-Dog Timer Time-Out Indicator

If this bit is set to 1, a WDT time-out occurred. A Power-On Reset resets this pin. A STOP Mode Recovery from a change in an input pin also resets this bit. Reading this register resets this bit.

EXT—External Reset Indicator

If this bit is set to 1, a Reset initiated by the external $\overline{\text{RESET}}$ pin occurred. A Power-On Reset or a STOP Mode Recovery from a change in an input pin resets this bit. Reading this register resets this bit.



Reserved
These bits are reserved and must be 0.

Watch-Dog Timer Reload Upper, High and Low Byte Registers

The Watch-Dog Timer Reload Upper, High and Low Byte (WDTU, WDTH, WDTL) registers (Tables 47 through 49) form the 24-bit reload value that is loaded into the Watch-Dog Timer when a WDT instruction executes. The 24-bit reload value is {WDTU[7:0], WDTH[7:0], WDTL[7:0]}. Writing to these registers sets the desired Reload Value. Reading from these registers returns the current Watch-Dog Timer count value.



Caution: The 24-bit WDT Reload Value must not be set to a value less than 000004H.

Table 47. Watch-Dog Timer Reload Upper Byte Register (WDTU)

BITS	7	6	5	4	3	2	1	0
FIELD	WDTU							
RESET	1	1	1	1	1	1	1	1
R/W	R/W*	R/W*	R/W*	R/W*	R/W*	R/W*	R/W*	R/W*
ADDR	FF1H							
R/W* - Read returns the current WDT count value. Write sets the desired Reload Value.								

WDTU—WDT Reload Upper Byte

Most significant byte (MSB), Bits[23:16], of the 24-bit WDT reload value.

Table 48. Watch-Dog Timer Reload High Byte Register (WDTH)

BITS	7	6	5	4	3	2	1	0
FIELD	WDTH							
RESET	1	1	1	1	1	1	1	1
R/W	R/W*	R/W*	R/W*	R/W*	R/W*	R/W*	R/W*	R/W*
ADDR	FF2H							
R/W* - Read returns the current WDT count value. Write sets the desired Reload Value.								



WDTH—WDT Reload High Byte

Middle byte, Bits[15:8], of the 24-bit WDT reload value.

Table 49. Watch-Dog Timer Reload Low Byte Register (WDTL)

BITS	7	6	5	4	3	2	1	0
FIELD	WDTL							
RESET	1	1	1	1	1	1	1	1
R/W	R/W*	R/W*	R/W*	R/W*	R/W*	R/W*	R/W*	R/W*
ADDR	FF3H							
R/W* - Read returns the current WDT count value. Write sets the desired Reload Value.								

WDTL—WDT Reload Low

Least significant byte (LSB), Bits[7:0], of the 24-bit WDT reload value.

UART

Overview

The Universal Asynchronous Receiver/Transmitter (UART) is a full-duplex communication channel capable of handling asynchronous data transfers. The UART uses a single 8-bit data mode with selectable parity. Features of the UART include:

- 8-bit asynchronous data transfer
- Selectable even- and odd-parity generation and checking
- Option of one or two Stop bits
- Separate transmit and receive interrupts
- Framing, parity, overrun and break detection
- Separate transmit and receive enables
- 16-bit Baud Rate Generator (BRG)
- Selectable Multiprocessor (9-bit) mode with three configurable interrupt schemes
- Baud Rate Generator timer mode
- Driver Enable output for external bus transceivers

Architecture

The UART consists of three primary functional blocks: transmitter, receiver, and baud rate generator. The UART's transmitter and receiver function independently, but employ the same baud rate and data format. Figure 11 illustrates the UART architecture.

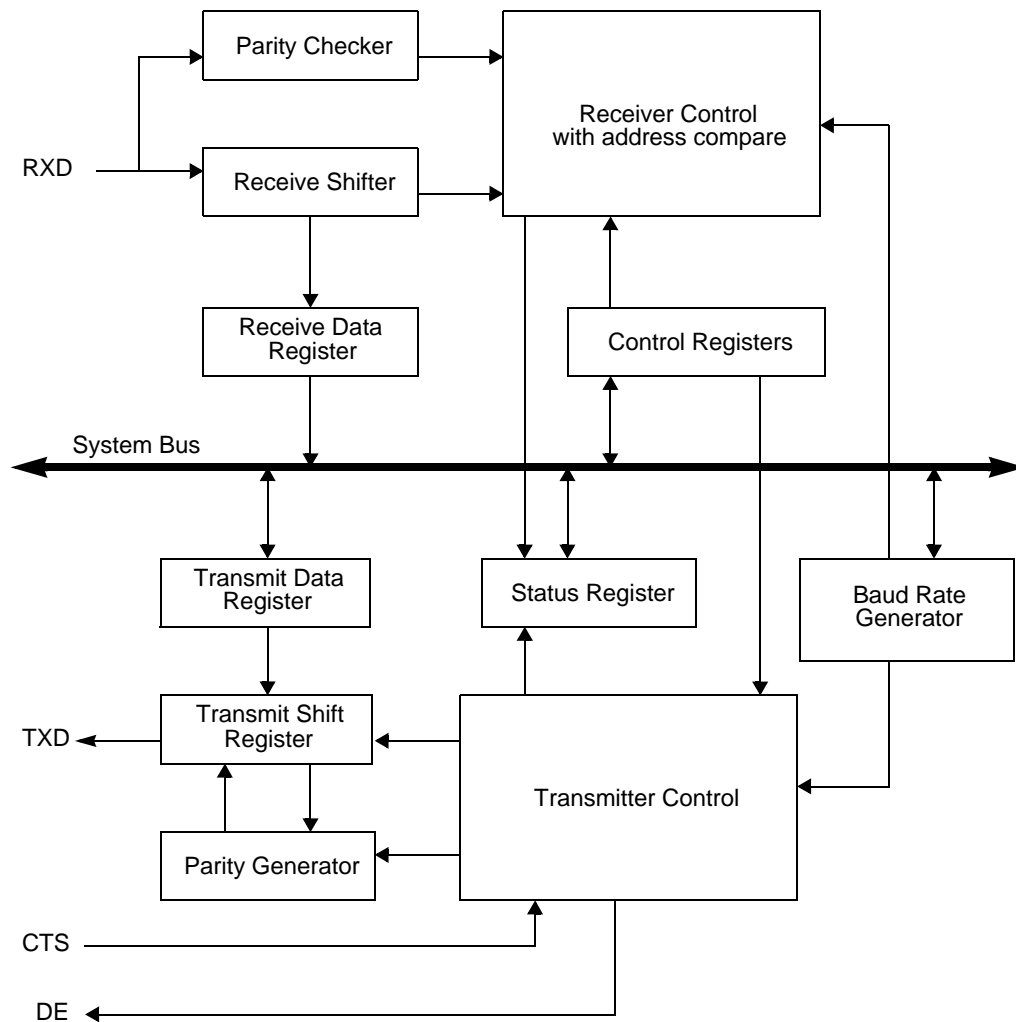

Figure 11. UART Block Diagram

Operation

Data Format

The UART always transmits and receives data in an 8-bit data format, least-significant bit first. An even or odd parity bit can be optionally added to the data stream. Each character begins with an active Low Start bit and ends with either 1 or 2 active High Stop bits.

Figures 12 and 13 illustrates the asynchronous data format employed by the UART without parity and with parity, respectively.

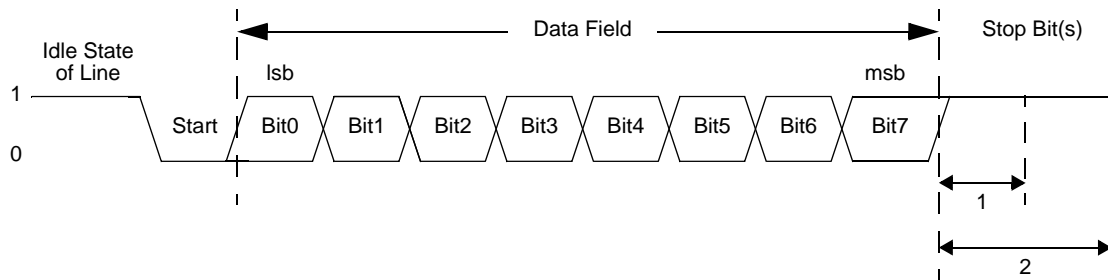

Figure 12. UART Asynchronous Data Format without Parity

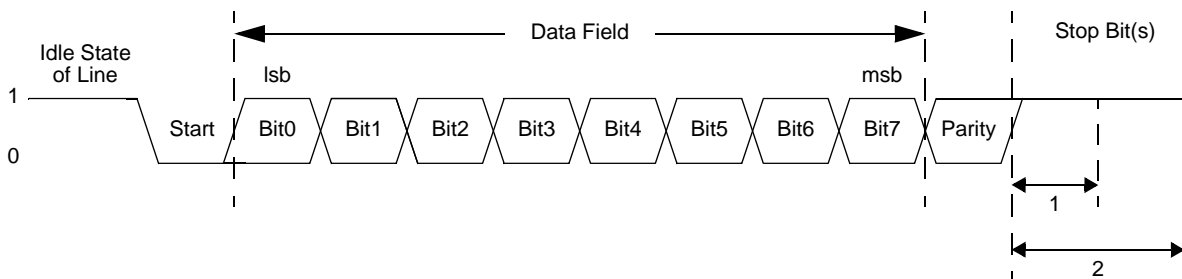

Figure 13. UART Asynchronous Data Format with Parity

Transmitting Data using the Polled Method

Follow these steps to transmit data using the polled method of operation:

1. Write to the UART Baud Rate High and Low Byte registers to set the desired baud rate.
2. Enable the UART pin functions by configuring the associated GPIO Port pins for alternate function operation.
3. If multiprocessor mode is desired, write to the UART Control 1 register to enable Multiprocessor (9-bit) mode functions.
 - Set the Multiprocessor Mode Select (MPEN) to Enable Multiprocessor mode.
4. Write to the UART Control 0 register to:
 - Set the transmit enable bit (TEN) to enable the UART for data transmission
 - If parity is desired and multiprocessor mode is not enabled, set the parity enable bit (PEN) and select either even or odd parity (PSEL).



- Set or clear the $\overline{\text{CTSE}}$ bit to enable or disable control from the remote receiver using the $\overline{\text{CTS}}$ pin.
5. Check the TDRE bit in the UART Status 0 register to determine if the Transmit Data register is empty (indicated by a 1). If empty, continue to Step 6. If the Transmit Data register is full (indicated by a 0), continue to monitor the TDRE bit until the Transmit Data register becomes available to receive new data.
 6. Write the UART Control 1 register to select the outgoing address bit.
 - Set the Multiprocessor Bit Transmitter (MPBT) if sending an address byte, clear it if sending a data byte.
 7. Write the data byte to the UART Transmit Data register. The transmitter automatically transfers the data to the Transmit Shift register and transmits the data.
 8. If desired and multiprocessor mode is enabled, make any changes to the Multiprocessor Bit Transmitter (MPBT) value.
 9. To transmit additional bytes, return to Step 5.

Transmitting Data using the Interrupt-Driven Method

The UART Transmitter interrupt indicates the availability of the Transmit Data register to accept new data for transmission. Follow these steps to configure the UART for interrupt-driven data transmission:

1. Write to the UART Baud Rate High and Low Byte registers to set the desired baud rate.
2. Enable the UART pin functions by configuring the associated GPIO Port pins for alternate function operation.
3. Execute a DI instruction to disable interrupts.
4. Write to the Interrupt control registers to enable the UART Transmitter interrupt and set the desired priority.
5. If multiprocessor mode is desired, write to the UART Control 1 register to enable Multiprocessor (9-bit) mode functions.
 - Set the Multiprocessor Mode Select (MPEN) to Enable Multiprocessor mode.
6. Write to the UART Control 0 register to:
 - Set the transmit enable bit (TEN) to enable the UART for data transmission
 - Enable parity, if desired and if multiprocessor mode is not enabled, and select either even or odd parity.
 - Set or clear the $\overline{\text{CTSE}}$ bit to enable or disable control from the remote receiver via the $\overline{\text{CTS}}$ pin.
7. Execute an EI instruction to enable interrupts.



The UART is now configured for interrupt-driven data transmission. Because the UART Transmit Data register is empty, an interrupt is generated immediately. When the UART Transmit interrupt is detected, the associated interrupt service routine (ISR) performs the following:

1. Write the UART Control 1 register to select the outgoing address bit:
 - Set the Multiprocessor Bit Transmitter (MPBT) if sending an address byte, clear it if sending a data byte.
2. Write the data byte to the UART Transmit Data register. The transmitter automatically transfers the data to the Transmit Shift register and transmits the data.
3. Clear the UART Transmit interrupt bit in the applicable Interrupt Request register.
4. Execute the IRET instruction to return from the interrupt-service routine and wait for the Transmit Data register to again become empty.

Receiving Data using the Polled Method

Follow these steps to configure the UART for polled data reception:

1. Write to the UART Baud Rate High and Low Byte registers to set the desired baud rate.
2. Enable the UART pin functions by configuring the associated GPIO Port pins for alternate function operation.
3. Write to the UART Control 1 register to enable Multiprocessor mode functions, if desired.
4. Write to the UART Control 0 register to:
 - Set the receive enable bit (REN) to enable the UART for data reception
 - Enable parity, if desired and if multiprocessor mode is not enabled, and select either even or odd parity.
5. Check the RDA bit in the UART Status 0 register to determine if the Receive Data register contains a valid data byte (indicated by a 1). If RDA is set to 1 to indicate available data, continue to Step 5. If the Receive Data register is empty (indicated by a 0), continue to monitor the RDA bit awaiting reception of the valid data.
6. Read data from the UART Receive Data register. If operating in Multiprocessor (9-bit) mode, further actions may be required depending on the Multiprocessor Mode bits MPMD[1:0].
7. Return to Step 4 to receive additional data.

Receiving Data using the Interrupt-Driven Method

The UART Receiver interrupt indicates the availability of new data (as well as error conditions). Follow these steps to configure the UART receiver for interrupt-driven operation:



1. Write to the UART Baud Rate High and Low Byte registers to set the desired baud rate.
2. Enable the UART pin functions by configuring the associated GPIO Port pins for alternate function operation.
3. Execute a DI instruction to disable interrupts.
4. Write to the Interrupt control registers to enable the UART Receiver interrupt and set the desired priority.
5. Clear the UART Receiver interrupt in the applicable Interrupt Request register.
6. Write to the UART Control 1 Register to enable Multiprocessor (9-bit) mode functions, if desired.
 - Set the Multiprocessor Mode Select (MPEN) to Enable Multiprocessor mode.
 - Set the Multiprocessor Mode Bits, MPMD [1 : 0] , to select the desired address matching scheme.
 - Configure the UART to interrupt on received data and errors or errors only (interrupt on errors only is unlikely to be useful for Z8 Encore! devices without a DMA block)
7. Write the device address to the Address Compare Register (automatic multiprocessor modes only).
8. Write to the UART Control 0 register to:
 - Set the receive enable bit (REN) to enable the UART for data reception
 - Enable parity, if desired and if multiprocessor mode is not enabled, and select either even or odd parity.
9. Execute an EI instruction to enable interrupts.

The UART is now configured for interrupt-driven data reception. When the UART Receiver interrupt is detected, the associated interrupt service routine (ISR) performs the following:

1. Check the UART Status 0 register to determine the source of the interrupt - error, break, or received data.
2. If the interrupt was due to data available, read the data from the UART Receive Data register. If operating in Multiprocessor (9-bit) mode, further actions may be required depending on the Multiprocessor Mode bits MPMD[1:0].
3. Clear the UART Receiver interrupt in the applicable Interrupt Request register.
4. Execute the IRET instruction to return from the interrupt-service routine and await more data.



Clear To Send ($\overline{\text{CTS}}$) Operation

The CTS pin, if enabled by the CTSE bit of the UART Control 0 register, performs flow control on the outgoing transmit datastream. The Clear To Send ($\overline{\text{CTS}}$) input pin is sampled one system clock before beginning any new character transmission. To delay transmission of the next data character, an external receiver must deassert $\overline{\text{CTS}}$ at least one system clock cycle before a new data transmission begins. For multiple character transmissions, this would typically be done during Stop Bit transmission. If $\overline{\text{CTS}}$ deasserts in the middle of a character transmission, the current character is sent completely.

Multiprocessor (9-bit) Mode

The UART has a Multiprocessor (9-bit) mode that uses an extra (9th) bit for selective communication when a number of processors share a common UART bus. In Multiprocessor mode (also referred to as 9-Bit mode), the multiprocessor bit (MP) is transmitted immediately following the 8-bits of data and immediately preceding the Stop bit(s) as illustrated in Figure 14. The character format is:

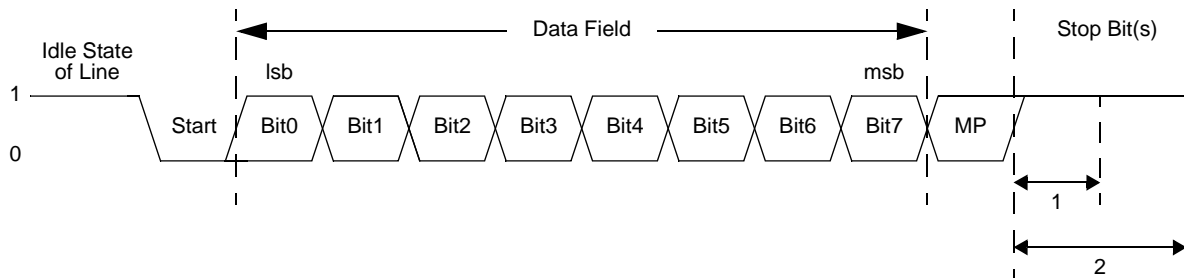

Figure 14. UART Asynchronous Multiprocessor Mode Data Format

In Multiprocessor (9-bit) mode, the Parity bit location (9th bit) becomes the Multiprocessor control bit. The UART Control 1 and Status 1 registers provide Multiprocessor (9-bit) mode control and status information. If an automatic address matching scheme is enabled, the UART Address Compare register holds the network address of the device.

Multiprocessor (9-bit) Mode Receive Interrupts

When multiprocessor mode is enabled, the UART will only process frames addressed to it. The determination of whether a frame of data is addressed to the UART can be made in hardware, software or some combination of the two, depending on the multiprocessor configuration bits. In general, the address compare feature reduces the load on the CPU, since it does not need to access the UART when it receives data directed to other devices on the multi-node network. The following three multi-processor modes are available in hardware:

- Interrupt on all address bytes

- Interrupt on matched address bytes and correctly framed data bytes
- Interrupt only on correctly framed data bytes

These modes are selected with MPMD [1 : 0] in the UART Control 1 Register. For all multiprocessor modes, bit MPEN of the UART Control 1 Register must be set to 1.

The first scheme is enabled by writing 01b to MPMD [1 : 0]. In this mode, all incoming address bytes cause an interrupt, while data bytes never cause an interrupt. The interrupt service routine must manually check the address byte that caused triggered the interrupt. If it matches the UART address, the software should clear MPMD [0]. At this point, each new incoming byte will interrupt the CPU. The software is then responsible for determining the end of the frame. It will check for this by reading the MPRX bit of the UART Status 1 Register for each incoming byte. If MPRX=1, then a new frame has begun. If the address of this new frame is different from the UART's address, then MPMD [0] should be set to 1 causing the UART interrupts to go inactive until the next address byte. If the new frame's address matches the UART's, then the data in the new frame should be processed as well.

Setting MPMD [1 : 0] to 10b and writing the UART's address into the UART Address Compare Register. This mode introduces more hardware control, interrupting only on frames that match the UART's address. When an incoming address byte does not match the UART's address, it is ignored. All successive data bytes in this frame are also ignored. When a matching address byte occurs, an interrupt is issued and further interrupts will now occur on each successive data byte. The first data byte in the frame will have the NEWFRM=1 in the UART Status 1 Register. When the next address byte occurs, the hardware will compare it to the UART's address. If there is a match, the interrupts will continue and the NEWFRM bit will be set for the first byte of the new frame. If there is no match, then the UART to ignore all incoming bytes until the next address match.

The third scheme is enabled by setting MPMD [1 : 0] to 11b and by writing the UART's address into the UART Address Compare Register. This mode is identical to the second scheme, except that there are no interrupts on address bytes. The first data byte of each frame is still accompanied by a NEWFRM assertion.

External Driver Enable

The UART provides a Driver Enable (DE) signal for off-chip bus transceivers. This feature reduces the software overhead associated with using a GPIO pin to control the transceiver when communicating on a multi-transceiver bus, such as RS-485.

Driver Enable is an active High signal that envelopes the entire transmitted data frame including parity and Stop bits as illustrated in Figure 15. The Driver Enable signal asserts when a byte is written to the UART Transmit Data register. The Driver Enable signal asserts at least one UART bit period and no greater than two UART bit periods before the Start bit is transmitted. This allows a setup time to enable the transceiver. The Driver Enable signal deasserts one system clock period after the last Stop bit is transmitted. This one system clock delay allows both time for data to clear the transceiver before disabling it, as well as the ability to determine if another character follows the current character. In

the event of back to back characters (new data must be written to the Transmit Data Register before the previous character is completely transmitted) the DE signal is not deasserted between characters. The DEPOL bit in the UART Control Register 1 sets the polarity of the Driver Enable signal.

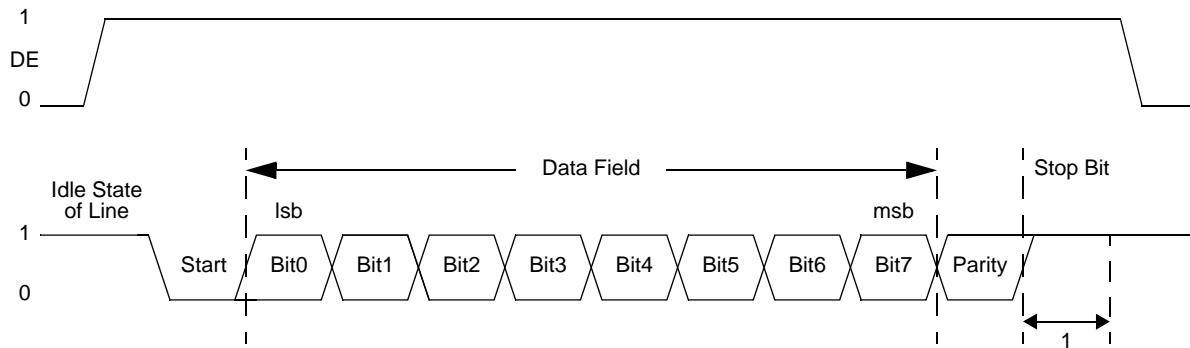

Figure 15. UART Driver Enable Signal Timing (shown with 1 Stop Bit and Parity)

The Driver Enable to Start bit setup time is calculated as follows:

$$\left(\frac{1}{\text{Baud Rate (Hz)}} \right) \leq \text{DE to Start Bit Setup Time (s)} \leq \left(\frac{2}{\text{Baud Rate (Hz)}} \right)$$

UART Interrupts

The UART features separate interrupts for the transmitter and the receiver. In addition, when the UART primary functionality is disabled, the Baud Rate Generator can also function as a basic timer with interrupt capability.

Transmitter Interrupts

The transmitter generates a single interrupt when the Transmit Data Register Empty bit (TDRE) is set to 1. This indicates that the transmitter is ready to accept new data for transmission. The TDRE interrupt occurs after the Transmit shift register has shifted the first bit of data out. At this point, the Transmit Data register may be written with the next character to send. This provides 7 bit periods of latency to load the Transmit Data register before the Transmit shift register completes shifting the current character. Writing to the UART Transmit Data register clears the TDRE bit to 0.

Receiver Interrupts

The receiver generates an interrupt when any of the following occurs:



- A data byte has been received and is available in the UART Receive Data register. This interrupt can be disabled independent of the other receiver interrupt sources. The received data interrupt occurs once the receive character has been received and placed in the Receive Data register. Software must respond to this received data available condition before the next character is completely received to avoid an overrun error. Note that in multiprocessor mode (MPEN = 1), the receive data interrupts are dependent on the multiprocessor configuration and the most recent address byte.
- A break is received
- An overrun is detected
- A data framing error is detected

UART Overrun Errors

When an overrun error condition occurs the UART prevents overwriting of the valid data currently in the Receive Data register. The Break Detect and Overrun status bits are not displayed until after the valid data has been read.

After the valid data has been read, the UART Status 0 register is updated to indicate the overrun condition (and Break Detect, if applicable). The RDA bit is set to 1 to indicate that the Receive Data register contains a data byte. However, because the overrun error occurred, this byte may not contain valid data and should be ignored. The BRKD bit indicates if the overrun was caused by a break condition on the line. After reading the status byte indicating an overrun error, the Receive Data register must be read again to clear the error bits in the UART Status 0 register. Updates to the Receive Data register occur only when the next data word is received.

UART Data and Error Handling Procedure

Figure 16 illustrates the recommended procedure for use in UART receiver interrupt service routines.

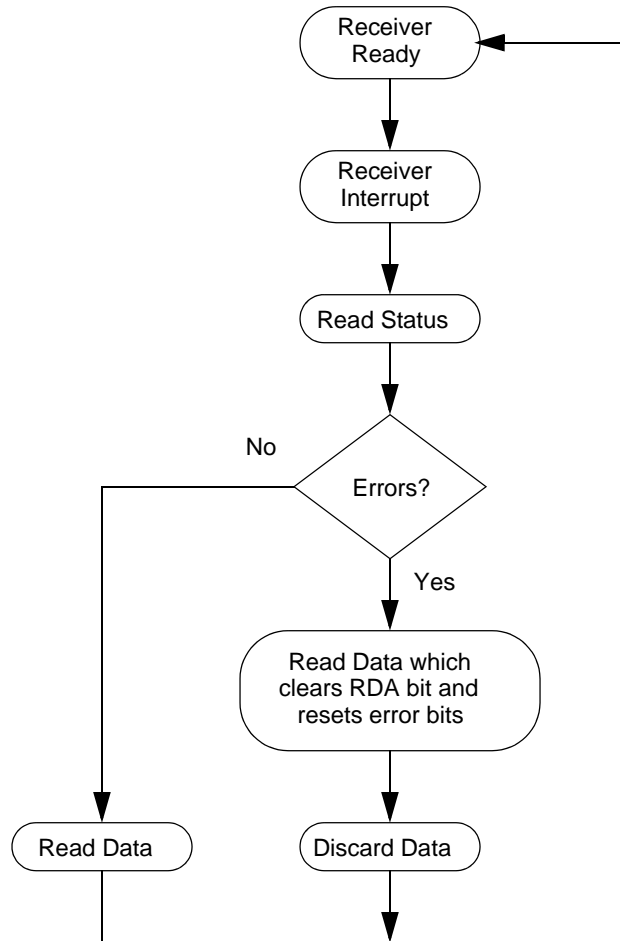

Figure 16. UART Receiver Interrupt Service Routine Flow

Baud Rate Generator Interrupts

If the Baud Rate Generator (BRG) interrupt enable is set, the UART Receiver interrupt asserts when the UART Baud Rate Generator reloads. This action allows the Baud Rate Generator to function as an additional counter if the UART functionality is not employed.

UART Baud Rate Generator

The UART Baud Rate Generator creates a lower frequency baud rate clock for data transmission. The input to the Baud Rate Generator is the system clock. The UART Baud Rate



High and Low Byte registers combine to create a 16-bit baud rate divisor value (BRG[15:0]) that sets the data transmission rate (baud rate) of the UART. The UART data rate is calculated using the following equation:

$$\text{UART Data Rate (bits/s)} = \frac{\text{System Clock Frequency (Hz)}}{16 \times \text{UART Baud Rate Divisor Value}}$$

When the UART is disabled, the Baud Rate Generator can function as a basic 16-bit timer with interrupt on time-out. To configure the Baud Rate Generator as a timer with interrupt on time-out, complete the following procedure:

1. Disable the UART by clearing the REN and TEN bits in the UART Control 0 register to 0.
2. Load the desired 16-bit count value into the UART Baud Rate High and Low Byte registers.
3. Enable the Baud Rate Generator timer function and associated interrupt by setting the BIRQ bit in the UART Control 1 register to 1.

UART Control Register Definitions

The UART control registers support the UART and the associated Infrared Encoder/Decoders. For more information on the infrared operation, refer to the **Infrared Encoder/Decoder** chapter on page 102.

UART Transmit Data Register

Data bytes written to the UART Transmit Data register (Table 50) are shifted out on the TXD_x pin. The Write-only UART Transmit Data register shares a Register File address with the Read-only UART Receive Data register.

Table 50. UART Transmit Data Register (U0TXD)

BITS	7	6	5	4	3	2	1	0
FIELD	TXD							
RESET	X	X	X	X	X	X	X	X
R/W	W	W	W	W	W	W	W	W
ADDR	F40H							

TXD—Transmit Data
UART transmitter data byte to be shifted out through the TXD_x pin.



UART Receive Data Register

Data bytes received through the RXD_x pin are stored in the UART Receive Data register (Table 51). The Read-only UART Receive Data register shares a Register File address with the Write-only UART Transmit Data register.

Table 51. UART Receive Data Register (U0RXD)

BITS	7	6	5	4	3	2	1	0
FIELD	RXD							
RESET	X	X	X	X	X	X	X	X
R/W	R	R	R	R	R	R	R	R
ADDR	F40H							

RXD—Receive Data
UART receiver data byte from the RXD_x pin

UART Status 0 Register

The UART Status 0 and Status 1 registers (Table 52 and 53) identify the current UART operating configuration and status.

Table 52. UART Status 0 Register (U0STAT0)

BITS	7	6	5	4	3	2	1	0
FIELD	RDA	PE	OE	FE	BRKD	TDRE	TXE	CTS
RESET	0	0	0	0	0	1	1	X
R/W	R	R	R	R	R	R	R	R
ADDR	F41H							

RDA—Receive Data Available
This bit indicates that the UART Receive Data register has received data. Reading the UART Receive Data register clears this bit.
0 = The UART Receive Data register is empty.
1 = There is a byte in the UART Receive Data register.

PE—Parity Error
This bit indicates that a parity error has occurred. Reading the UART Receive Data register clears this bit.



0 = No parity error has occurred.

1 = A parity error has occurred.

OE—Overrun Error

This bit indicates that an overrun error has occurred. An overrun occurs when new data is received and the UART Receive Data register has not been read. If the RDA bit is reset to 0, then reading the UART Receive Data register clears this bit.

0 = No overrun error occurred.

1 = An overrun error occurred.

FE—Framing Error

This bit indicates that a framing error (no Stop bit following data reception) was detected. Reading the UART Receive Data register clears this bit.

0 = No framing error occurred.

1 = A framing error occurred.

BRKD—Break Detect

This bit indicates that a break occurred. If the data bits, parity/multiprocessor bit, and Stop bit(s) are all zeros then this bit is set to 1. Reading the UART Receive Data register clears this bit.

0 = No break occurred.

1 = A break occurred.

TDRE—Transmitter Data Register Empty

This bit indicates that the UART Transmit Data register is empty and ready for additional data. Writing to the UART Transmit Data register resets this bit.

0 = Do not write to the UART Transmit Data register.

1 = The UART Transmit Data register is ready to receive an additional byte to be transmitted.

TXE—Transmitter Empty

This bit indicates that the transmit shift register is empty and character transmission is finished.

0 = Data is currently transmitting.

1 = Transmission is complete.



CTS— $\overline{\text{CTS}}$ signal

When this bit is read it returns the level of the $\overline{\text{CTS}}$ signal.

UART Status 1 Register

This register contains multiprocessor control and status bits.

Table 53. UART Status 1 Register (U0STAT1)

BITS	7	6	5	4	3	2	1	0
FIELD	Reserved						NEWFRM	MPRX
RESET	0	0	0	0	0	0	0	0
R/W	R	R	R	R	R/W	R/W	R	R
ADDR	F44H							

Reserved—Must be 0.

NEWFRM—Status bit denoting the start of a new frame. Reading the UART Receive Data register resets this bit to 0.

0 = The current byte is not the first data byte of a new frame.

1 = The current byte is the first data byte of a new frame.

MPRX—Multiprocessor Receive

Returns the value of the last multiprocessor bit received. Reading from the UART Receive Data register resets this bit to 0.

UART Control 0 and Control 1 Registers

The UART Control 0 and Control 1 registers (Tables 54 and 55) configure the properties of the UART's transmit and receive operations. The UART Control registers must not be written while the UART is enabled.

Table 54. UART Control 0 Register (U0CTL0)

BITS	7	6	5	4	3	2	1	0
FIELD	TEN	REN	CTSE	PEN	PSEL	SBRK	STOP	LBEN
RESET	0	0	0	0	0	0	0	0
R/W	R/W	R/W	R/W	R/W	R/W	R/W	R/W	R/W
ADDR	F42H							



TEN—Transmit Enable

This bit enables or disables the transmitter. The enable is also controlled by the $\overline{\text{CTS}}$ signal and the CTSE bit. If the $\overline{\text{CTS}}$ signal is low and the CTSE bit is 1, the transmitter is enabled.

0 = Transmitter disabled.

1 = Transmitter enabled.

REN—Receive Enable

This bit enables or disables the receiver.

0 = Receiver disabled.

1 = Receiver enabled.

CTSE—CTS Enable

0 = The $\overline{\text{CTS}}$ signal has no effect on the transmitter.

1 = The UART recognizes the $\overline{\text{CTS}}$ signal as an enable control from the transmitter.

PEN—Parity Enable

This bit enables or disables parity. Even or odd is determined by the PSEL bit.

0 = Parity is disabled.

1 = The transmitter sends data with an additional parity bit and the receiver receives an additional parity bit.

PSEL—Parity Select

0 = Even parity is transmitted and expected on all received data.

1 = Odd parity is transmitted and expected on all received data.

SBRK—Send Break

This bit pauses or breaks data transmission. Sending a break interrupts any transmission in progress, so ensure that the transmitter has finished sending data before setting this bit.

0 = No break is sent.

1 = The output of the transmitter is zero.

STOP—Stop Bit Select

0 = The transmitter sends one stop bit.

1 = The transmitter sends two stop bits.



LBEN—Loop Back Enable
0 = Normal operation.
1 = All transmitted data is looped back to the receiver.

Table 55. UART Control 1 Register (U0CTL1)

BITS	7	6	5	4	3	2	1	0
FIELD	MPMD[1]	MPEN	MPMD[0]	MPBT	DEPOL	BRGCTL	RDAIRQ	IREN
RESET	0	0	0	0	0	0	0	0
R/W	R/W	R/W	R/W	R/W	R/W	R/W	R/W	R/W
ADDR	F43H							

MPMD[1:0]—Multiprocessor Mode
If Multiprocessor (9-bit) mode is enabled,
00 = The UART generates an interrupt request on all received bytes (data and address).
01 = The UART generates an interrupt request only on received address bytes.
10 = The UART generates an interrupt request when a received address byte matches the value stored in the Address Compare Register and on all successive data bytes until an address mismatch occurs.
11 = The UART generates an interrupt request on all received data bytes for which the most recent address byte matched the value in the Address Compare Register.

MPEN—Multiprocessor (9-bit) Enable
This bit is used to enable Multiprocessor (9-bit) mode.
0 = Disable Multiprocessor (9-bit) mode.
1 = Enable Multiprocessor (9-bit) mode.

MPBT—Multiprocessor Bit Transmit
This bit is applicable only when Multiprocessor (9-bit) mode is enabled.
0 = Send a 0 in the multiprocessor bit location of the data stream (9th bit).
1 = Send a 1 in the multiprocessor bit location of the data stream (9th bit).

DEPOL—Driver Enable Polarity
0 = DE signal is Active High.
1 = DE signal is Active Low.

BRGCTL—Baud Rate Control
This bit causes different UART behavior depending on whether the UART receiver is enabled (REN = 1 in the UART Control 0 Register).

When the UART receiver is not enabled, this bit determines whether the Baud Rate Generator will issue interrupts.
0 = Reads from the Baud Rate High and Low Byte registers return the BRG Reload Value
1 = The Baud Rate Generator generates a receive interrupt when it counts down to zero.



Reads from the Baud Rate High and Low Byte registers return the current BRG count value.

When the UART receiver is enabled, this bit allows reads from the Baud Rate Registers to return the BRG count value instead of the Reload Value.

0 = Reads from the Baud Rate High and Low Byte registers return the BRG Reload Value.

1 = Reads from the Baud Rate High and Low Byte registers return the current BRG count value. Unlike the Timers, there is no mechanism to latch the High Byte when the Low Byte is read.

$\overline{\text{RDAIRQ}}$ —Receive Data Interrupt Enable

0 = Received data and receiver errors generates an interrupt request to the Interrupt Controller.

1 = Received data does not generate an interrupt request to the Interrupt Controller. Only receiver errors generate an interrupt request.

IREN—Infrared Encoder/Decoder Enable

0 = Infrared Encoder/Decoder is disabled. UART operates normally operation.

1 = Infrared Encoder/Decoder is enabled. The UART transmits and receives data through the Infrared Encoder/Decoder.

UART Address Compare Register

The UART Address Compare register stores the multi-node network address of the UART. When the MPMD[1] bit of UART Control Register 0 is set, all incoming address bytes will be compared to the value stored in the Address Compare register. Receive interrupts and RDA assertions will only occur in the event of a match.

Table 56. UART Address Compare Register (U0ADDR)

BITS	7	6	5	4	3	2	1	0
FIELD	COMP_ADDR							
RESET	0	0	0	0	0	0	0	0
R/W	R/W	R/W	R/W	R/W	R/W	R/W	R/W	R/W
ADDR	F45H							

COMP_ADDR—Compare Address

This 8-bit value is compared to the any incoming address bytes.



UART Baud Rate High and Low Byte Registers

The UART Baud Rate High and Low Byte registers (Tables 57 and 57) combine to create a 16-bit baud rate divisor value (BRG[15:0]) that sets the data transmission rate (baud rate) of the UART.

Table 57. UART Baud Rate High Byte Register (U0BRH)

BITS	7	6	5	4	3	2	1	0
FIELD	BRH							
RESET	1	1	1	1	1	1	1	1
R/W	R/W	R/W	R/W	R/W	R/W	R/W	R/W	R/W
ADDR	F46H							

Table 58. UART Baud Rate Low Byte Register (U0BRL)

BITS	7	6	5	4	3	2	1	0
FIELD	BRL							
RESET	1	1	1	1	1	1	1	1
R/W	R/W	R/W	R/W	R/W	R/W	R/W	R/W	R/w
ADDR	F47H							

The UART data rate is calculated using the following equation:

$$\text{UART Baud Rate (bits/s)} = \frac{\text{System Clock Frequency (Hz)}}{16 \times \text{UART Baud Rate Divisor Value}}$$

For a given UART data rate, the integer baud rate divisor value is calculated using the following equation:

$$\text{UART Baud Rate Divisor Value (BRG)} = \text{Round}\left(\frac{\text{System Clock Frequency (Hz)}}{16 \times \text{UART Data Rate (bits/s)}}\right)$$



The baud rate error relative to the desired baud rate is calculated using the following equation:

$$\text{UART Baud Rate Error (\%)} = 100 \times \left(\frac{\text{Actual Data Rate} - \text{Desired Data Rate}}{\text{Desired Data Rate}} \right)$$

For reliable communication, the UART baud rate error must never exceed 5 percent. Table 59 provides information on data rate errors for popular baud rates and commonly used crystal oscillator frequencies.

Table 59. UART Baud Rates

10.0 MHz System Clock				5.5296 MHz System Clock			
Desired Rate	BRG Divisor	Actual Rate	Error	Desired Rate	BRG Divisor	Actual Rate	Error
(kHz)	(Decimal)	(kHz)	(%)	(kHz)	(Decimal)	(kHz)	(%)
1250.0	N/A	N/A	N/A	1250.0	N/A	N/A	N/A
625.0	1	625.0	0.00	625.0	N/A	N/A	N/A
250.0	3	208.33	-16.67	250.0	1	345.6	38.24
115.2	5	125.0	8.51	115.2	3	115.2	0.00
57.6	11	56.8	-1.36	57.6	6	57.6	0.00
38.4	16	39.1	1.73	38.4	9	38.4	0.00
19.2	33	18.9	0.16	19.2	18	19.2	0.00
9.60	65	9.62	0.16	9.60	36	9.60	0.00
4.80	130	4.81	0.16	4.80	72	4.80	0.00
2.40	260	2.40	-0.03	2.40	144	2.40	0.00
1.20	521	1.20	-0.03	1.20	288	1.20	0.00
0.60	1042	0.60	-0.03	0.60	576	0.60	0.00
0.30	2083	0.30	0.2	0.30	1152	0.30	0.00

3.579545 MHz System Clock				1.8432 MHz System Clock			
Desired Rate	BRG Divisor	Actual Rate	Error	Desired Rate	BRG Divisor	Actual Rate	Error
(kHz)	(Decimal)	(kHz)	(%)	(kHz)	(Decimal)	(kHz)	(%)
1250.0	N/A	N/A	N/A	1250.0	N/A	N/A	N/A
625.0	N/A	N/A	N/A	625.0	N/A	N/A	N/A
250.0	1	223.72	-10.51	250.0	N/A	N/A	N/A



Table 59. UART Baud Rates (Continued)

115.2	2	111.9	-2.90	115.2	1	115.2	0.00
57.6	4	55.9	-2.90	57.6	2	57.6	0.00
38.4	6	37.3	-2.90	38.4	3	38.4	0.00
19.2	12	18.6	-2.90	19.2	6	19.2	0.00
9.60	23	9.73	1.32	9.60	12	9.60	0.00
4.80	47	4.76	-0.83	4.80	24	4.80	0.00
2.40	93	2.41	0.23	2.40	48	2.40	0.00
1.20	186	1.20	0.23	1.20	96	1.20	0.00
0.60	373	0.60	-0.04	0.60	192	0.60	0.00
0.30	746	0.30	-0.04	0.30	384	0.30	0.00



Infrared Encoder/Decoder

Overview

The Z8F082x family products contain a fully-functional, high-performance UART to Infrared Encoder/Decoder (Endec). The Infrared Endec is integrated with an on-chip UART to allow easy communication between the Z8 Encore!® and IrDA Physical Layer Specification, Version 1.3-compliant infrared transceivers. Infrared communication provides secure, reliable, low-cost, point-to-point communication between PCs, PDAs, cell phones, printers and other infrared enabled devices.

Architecture

Figure 17 illustrates the architecture of the Infrared Endec.

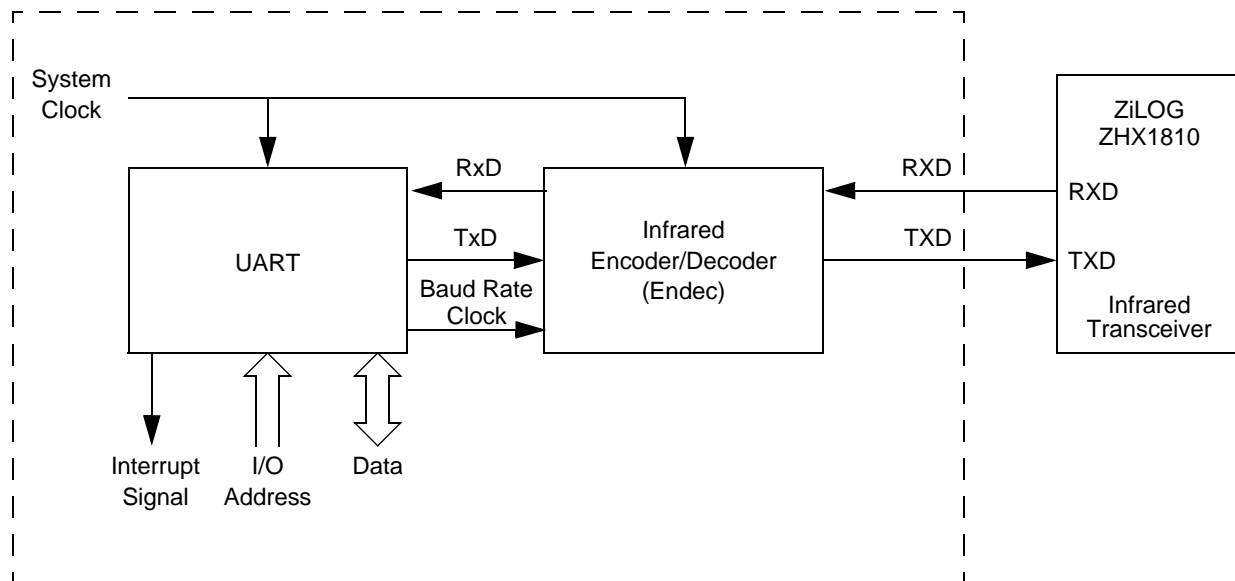

Figure 17. Infrared Data Communication System Block Diagram



Operation

When the Infrared Endec is enabled, the transmit data from the associated on-chip UART is encoded as digital signals in accordance with the IrDA standard and output to the infrared transceiver via the TXD pin. Likewise, data received from the infrared transceiver is passed to the Infrared Endec via the RXD pin, decoded by the Infrared Endec, and then passed to the UART. Communication is half-duplex, which means simultaneous data transmission and reception is not allowed.

The baud rate is set by the UART's Baud Rate Generator and supports IrDA standard baud rates from 9600 baud to 115.2 Kbaud. Higher baud rates are possible, but do not meet IrDA specifications. The UART must be enabled to use the Infrared Endec. The Infrared Endec data rate is calculated using the following equation:

$$\text{Infrared Data Rate (bits/s)} = \frac{\text{System Clock Frequency (Hz)}}{16 \times \text{UART Baud Rate Divisor Value}}$$

Transmitting IrDA Data

The data to be transmitted using the infrared transceiver is first sent to the UART. The UART's transmit signal (TXD) and baud rate clock are used by the IrDA to generate the modulation signal (IR_TXD) that drives the infrared transceiver. Each UART/Infrared data bit is 16-clocks wide. If the data to be transmitted is 1, the IR_TXD signal remains low for the full 16-clock period. If the data to be transmitted is 0, a 3-clock high pulse is output following a 7-clock low period. After the 3-clock high pulse, a 6-clock low pulse is output to complete the full 16-clock data period. Figure 18 illustrates IrDA data transmission. When the Infrared Endec is enabled, the UART's TXD signal is internal to the Z8F082x family products while the IR_TXD signal is output through the TXD pin.

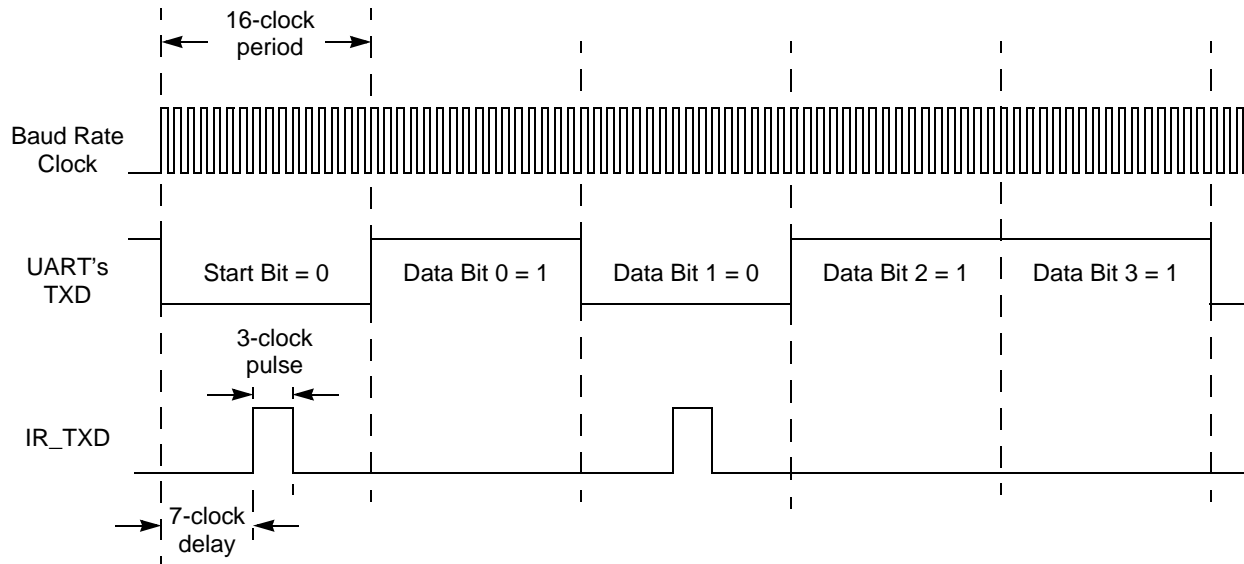

Figure 18. Infrared Data Transmission

Receiving IrDA Data

Data received from the infrared transceiver via the IR_RXD signal through the RXD pin is decoded by the Infrared Endec and passed to the UART. The UART's baud rate clock is used by the Infrared Endec to generate the demodulated signal (RXD) that drives the UART. Each UART/Infrared data bit is 16-clocks wide. Figure 19 illustrates data reception. When the Infrared Endec is enabled, the UART's RXD signal is internal to the Z8F082x family products while the IR_RXD signal is received through the RXD pin.

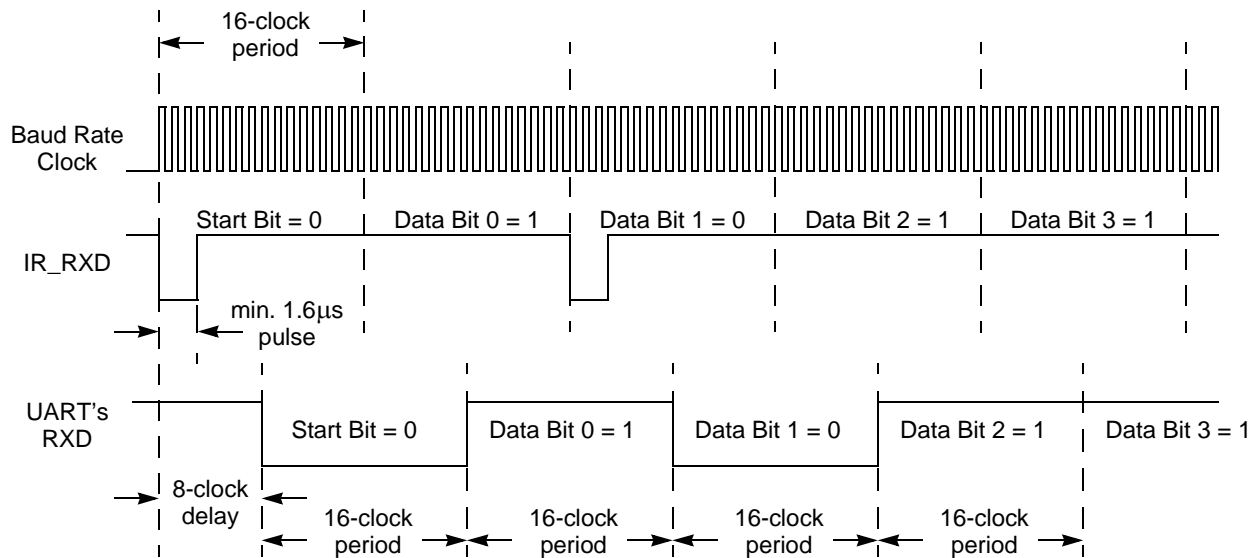

Figure 19. Infrared Data Reception



Caution: The system clock frequency must be at least 1.0MHz to ensure proper reception of the 1.6μs minimum width pulses allowed by the IrDA standard.

Endec Receiver Synchronization

The IrDA receiver uses a local baud rate clock counter (0 to 15 clock periods) to generate an input stream for the UART and to create a sampling window for detection of incoming pulses. The generated UART input (UART RXD) is delayed by 8 baud rate clock periods with respect to the incoming IrDA data stream. When a falling edge in the input data stream is detected, the Endec counter is reset. When the count reaches a value of 8, the UART RXD value is updated to reflect the value of the decoded data. When the count reaches 12 baud clock periods, the sampling window for the next incoming pulse opens. The window remains open until the count again reaches 8 (or in other words 24 baud clock periods since the previous pulse was detected). This gives the Endec a sampling window of minus four baudrate clocks to plus eight baudrate clocks around the expected time of an incoming pulse. If an incoming pulse is detected inside this window this process is repeated. If the incoming data is a logical 1 (no pulse), the Endec returns to the initial state and waits for the next falling edge. As each falling edge is detected, the Endec clock counter is reset, resynchronizing the Endec to the incoming signal. This allows the Endec to tolerate jitter and baud rate errors in the incoming data stream. Resynchronizing the Endec does not alter the operation of the UART, which ultimately receives the data. The UART is only synchronized to the incoming data stream when a Start bit is received.



Infrared Encoder/Decoder Control Register Definitions

All Infrared Endec configuration and status information is set by the UART control registers as defined beginning on [page 92](#).



Caution:

To prevent spurious signals during IrDA data transmission, set the IREN bit in the UART Control 1 register to 1 to enable the Infrared Encoder/Decoder *before* enabling the GPIO Port alternate function for the corresponding pin.

Serial Peripheral Interface

Overview

The Serial Peripheral Interface™ (SPI) is a synchronous interface allowing several SPI-type devices to be interconnected. SPI-compatible devices include EEPROMs, Analog-to-Digital Converters, and ISDN devices. Features of the SPI include:

- Full-duplex, synchronous, character-oriented communication
- Four-wire interface
- Data transfers rates up to a maximum of one-half the system clock frequency
- Error detection
- Dedicated Baud Rate Generator

The SPI is unavailable in 20-pin package devices.

Architecture

The SPI may be configured as either a Master (in single or multi-master systems) or a Slave as illustrated in Figures 20 through 22.

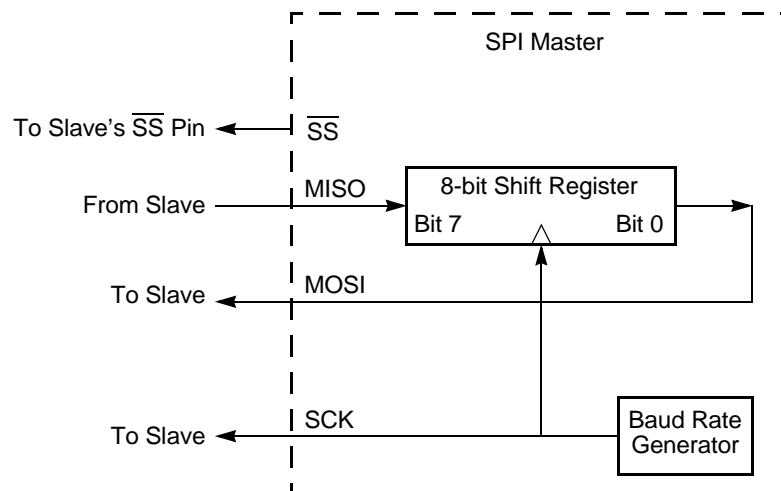

Figure 20. SPI Configured as a Master in a Single Master, Single Slave System

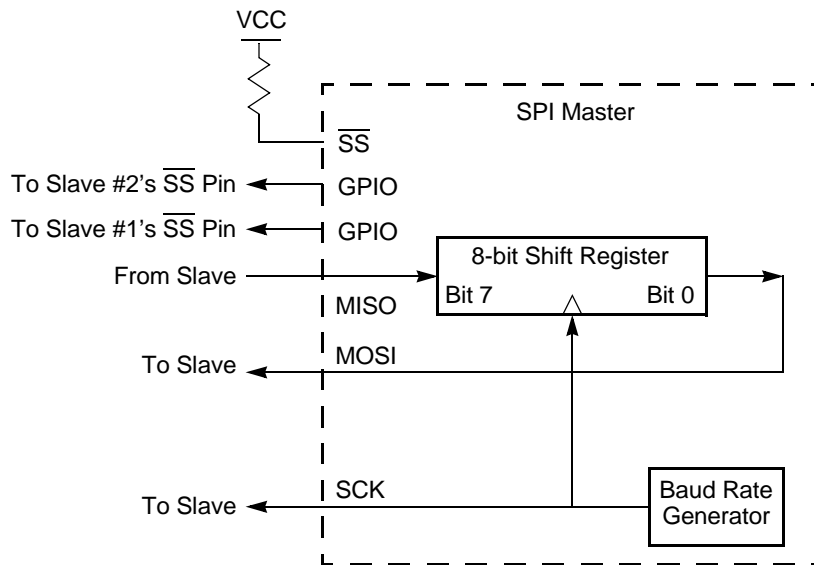

Figure 21. SPI Configured as a Master in a Single Master, Multiple Slave System

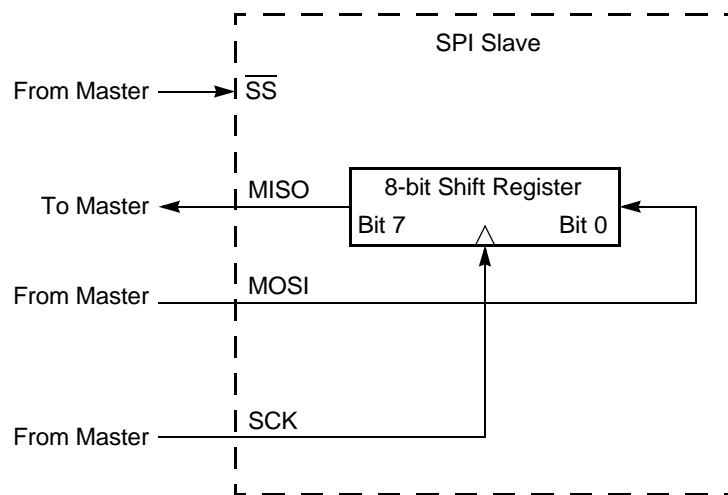

Figure 22. SPI Configured as a Slave

Operation

The SPI is a full-duplex, synchronous, character-oriented channel that supports a four-wire interface (serial clock, transmit, receive and Slave select). The SPI block consists of a transmit/receive shift register, a Baud Rate (clock) Generator and a control unit.



During an SPI transfer, data is sent and received simultaneously by both the Master and the Slave SPI devices. Separate signals are required for data and the serial clock. When an SPI transfer occurs, a multi-bit (typically 8-bit) character is shifted out one data pin and a multi-bit character is simultaneously shifted in on a second data pin. An 8-bit shift register in the Master and another 8-bit shift register in the Slave are connected as a circular buffer. The SPI shift register is single-buffered in the transmit and receive directions. New data to be transmitted cannot be written into the shift register until the previous transmission is complete and receive data (if valid) has been read.

SPI Signals

The four basic SPI signals are:

- MISO (Master-In, Slave-Out)
- MOSI (Master-Out, Slave-In)
- SCK (Serial Clock)
- \overline{SS} (Slave Select)

The following paragraphs discuss these SPI signals. Each signal is described in both Master and Slave modes.

Master-In, Slave-Out

The Master-In, Slave-Out (MISO) pin is configured as an input in a Master device and as an output in a Slave device. It is one of the two lines that transfer serial data, with the most significant bit sent first. The MISO pin of a Slave device is placed in a high-impedance state if the Slave is not selected. When the SPI is not enabled, this signal is in a high-impedance state.

Master-Out, Slave-In

The Master-Out, Slave-In (MOSI) pin is configured as an output in a Master device and as an input in a Slave device. It is one of the two lines that transfer serial data, with the most significant bit sent first. When the SPI is not enabled, this signal is in a high-impedance state.

Serial Clock

The Serial Clock (SCK) synchronizes data movement both in and out of the device through its MOSI and MISO pins. In MASTER mode, the SPI's Baud Rate Generator creates the serial clock. The Master drives the serial clock out its own SCK pin to the Slave's SCK pin. When the SPI is configured as a Slave, the SCK pin is an input and the clock signal from the Master synchronizes the data transfer between the Master and Slave devices. Slave devices ignore the SCK signal, unless the \overline{SS} pin is asserted. When configured as a slave, the SPI block requires a minimum SCK period of greater than or equal to 8 times the system (XIN) clock period.



The Master and Slave are each capable of exchanging a character of data during a sequence of NUMBITS clock cycles (refer to NUMBITS field in the SPIMODE register). In both Master and Slave SPI devices, data is shifted on one edge of the SCK and is sampled on the opposite edge where data is stable. Edge polarity is determined by the SPI phase and polarity control.

Slave Select

The active Low Slave Select (\overline{SS}) input signal selects a Slave SPI device. \overline{SS} must be Low prior to all data communication to and from the Slave device. \overline{SS} must stay Low for the full duration of each character transferred. The \overline{SS} signal may stay Low during the transfer of multiple characters or may deassert between each character.

When the SPI is configured as the only Master in an SPI system, the \overline{SS} pin can be set as either an input or an output. For communication between the Z8F082x family device's SPI Master and external Slave devices, the \overline{SS} signal, as an output, can assert the \overline{SS} input pin on one of the Slave devices. Other GPIO output pins can also be employed to select external SPI Slave devices.

When the SPI is configured as one Master in a multi-master SPI system, the \overline{SS} pin should be set as an input. The \overline{SS} input signal on the Master must be High. If the \overline{SS} signal goes Low (indicating another Master is driving the SPI bus), a Collision error flag is set in the SPI Status register.

SPI Clock Phase and Polarity Control

The SPI supports four combinations of serial clock phase and polarity using two bits in the SPI Control register. The clock polarity bit, CLKPOL, selects an active high or active low clock and has no effect on the transfer format. Table 60 lists the SPI Clock Phase and Polarity Operation parameters. The clock phase bit, PHASE, selects one of two fundamentally different transfer formats. For proper data transmission, the clock phase and polarity must be identical for the SPI Master and the SPI Slave. The Master always places data on the MOSI line a half-cycle before the receive clock edge (SCK signal), in order for the Slave to latch the data.

Table 60. SPI Clock Phase (PHASE) and Clock Polarity (CLKPOL) Operation

PHASE	CLKPOL	SCK Transmit Edge	SCK Receive Edge	SCK Idle State
0	0	Falling	Rising	Low
0	1	Rising	Falling	High
1	0	Rising	Falling	Low
1	1	Falling	Rising	High

Transfer Format PHASE Equals Zero

Figure 23 illustrates the timing diagram for an SPI transfer in which PHASE is cleared to 0. The two SCK waveforms show polarity with CLKPOL reset to 0 and with CLKPOL set to one. The diagram may be interpreted as either a Master or Slave timing diagram since the SCK Master-In/Slave-Out (MISO) and Master-Out/Slave-In (MOSI) pins are directly connected between the Master and the Slave.

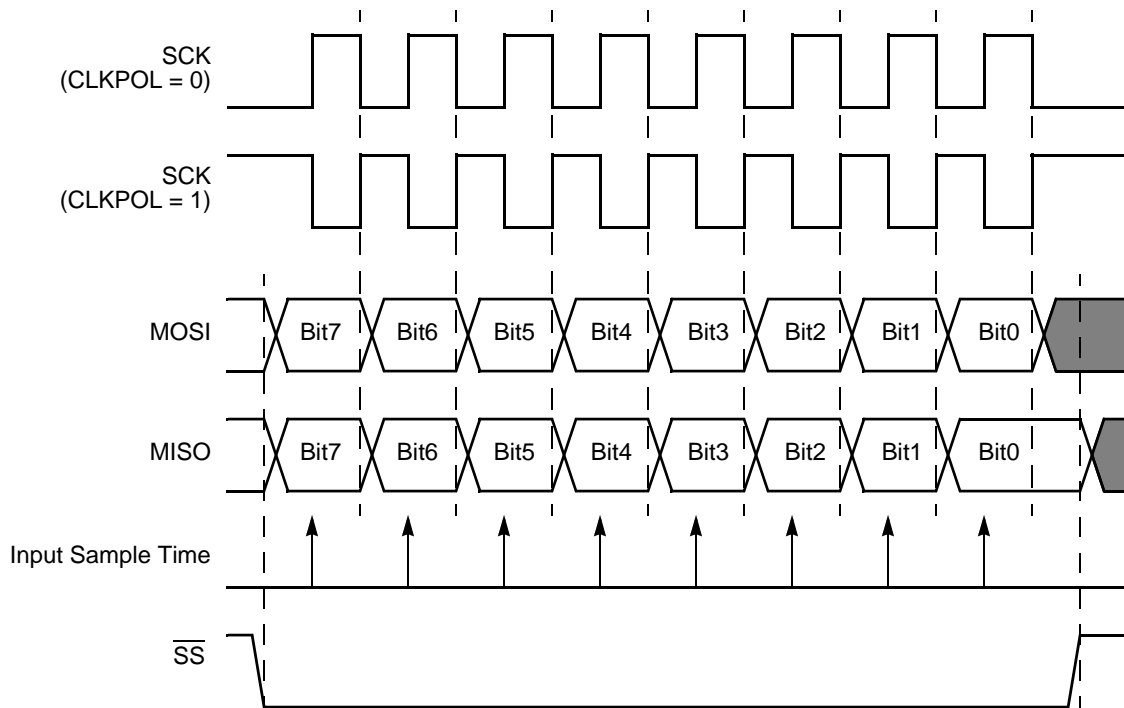

Figure 23. SPI Timing When PHASE is 0

Transfer Format PHASE Equals One

Figure 24 illustrates the timing diagram for an SPI transfer in which PHASE is one. Two waveforms are depicted for SCK, one for CLKPOL reset to 0 and another for CLKPOL set to 1.

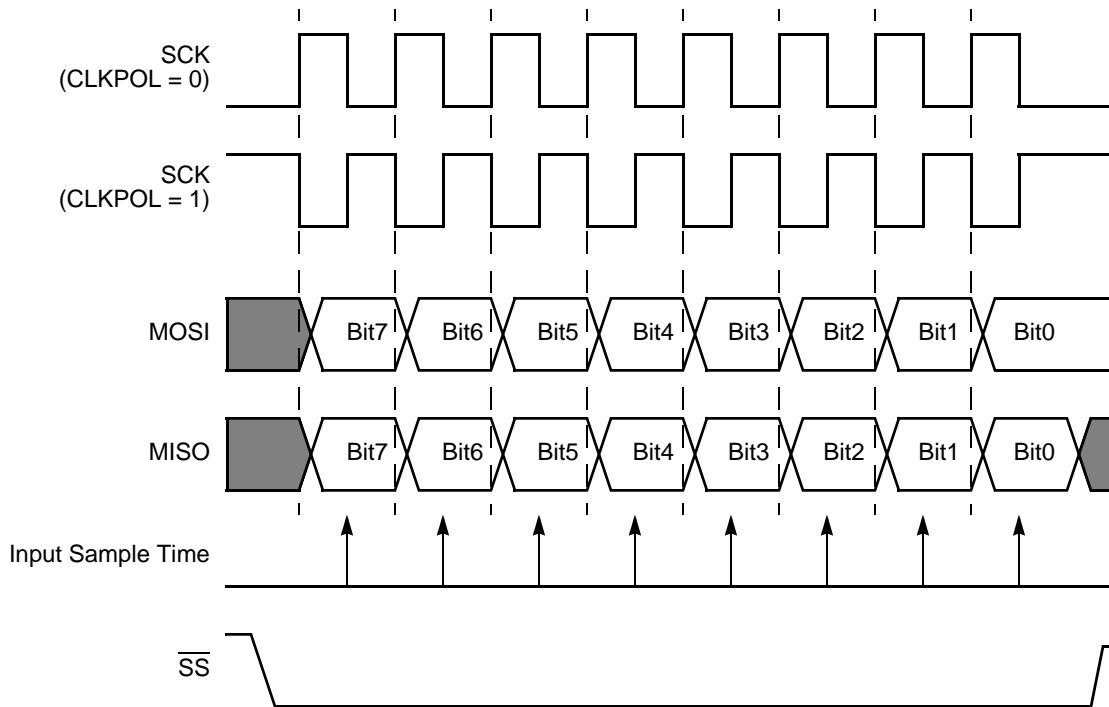

Figure 24. SPI Timing When PHASE is 1

Multi-Master Operation

In a multi-master SPI system, all SCK pins are tied together, all MOSI pins are tied together and all MISO pins are tied together. All SPI pins must then be configured in OPEN-DRAIN mode to prevent bus contention. At any one time, only one SPI device is configured as the Master and all other SPI devices on the bus are configured as Slaves. The Master enables a single Slave by asserting the \overline{SS} pin on that Slave only. Then, the single Master drives data out its SCK and MOSI pins to the SCK and MOSI pins on the Slaves (including those which are not enabled). The enabled Slave drives data out its MISO pin to the MISO Master pin.

For a Master device operating in a multi-master system, if the \overline{SS} pin is configured as an input and is driven Low by another Master, the COL bit is set to 1 in the SPI Status Register. The COL bit indicates the occurrence of a multi-master collision (mode fault error condition).

Slave Operation

The SPI block is configured for SLAVE mode operation by setting the SPIEN bit to 1 and the MMEN bit to 0 in the SPICTL register and setting the SSIO bit to 0 in the SPIMODE



register. The IRQE, PHASE, CLKPOL, WOR bits in the SPICTL register and the NUMBITS field in the SPIMODE register must be set to be consistent with the other SPI devices. The STR bit in the SPICTL register may be used if desired to force a “startup” interrupt. The BIRQ bit in the SPICTL register and the SSV bit in the SPIMODE register are not used in SLAVE mode. The SPI baud rate generator is not used in SLAVE mode so the SPIBRH and SPIBRL registers need not be initialized.

If the slave has data to send to the master, the data should be written to the SPIDAT register before the transaction starts (first edge of SCK when \overline{SS} is asserted). If the SPIDAT register is not written prior to the slave transaction, the MISO pin outputs whatever value is currently in the SPIDAT register.

Due to the delay resulting from synchronization of the SPI input signals to the internal system clock, the maximum SPICLK baud rate that can be supported in SLAVE mode is the system clock frequency (XIN) divided by 8. This rate is controlled by the SPI master.

Error Detection

The SPI contains error detection logic to support SPI communication protocols and recognize when communication errors have occurred. The SPI Status register indicates when a data transmission error has been detected.

Overrun (Write Collision)

An overrun error (write collision) indicates a write to the SPI Data register was attempted while a data transfer is in progress (in either master or slave modes). An overrun sets the OVR bit in the SPI Status register to 1. Writing a 1 to OVR clears this error flag. The data register is not altered when a write occurs while data transfer is in progress.

Mode Fault (Multi-Master Collision)

A mode fault indicates when more than one Master is trying to communicate at the same time (a multi-master collision). The mode fault is detected when the enabled Master's \overline{SS} pin is asserted. A mode fault sets the COL bit in the SPI Status register to 1. Writing a 1 to COL clears this error flag.

SLAVE Mode Abort

In SLAVE mode, if the \overline{SS} pin deasserts before all bits in a character have been transferred, the transaction aborts. When this condition occurs the ABT bit is set in the SPISTAT register as well as the IRQ bit (indicating the transaction is complete). The next time \overline{SS} asserts, the MISO pin outputs SPIDAT[7], regardless of where the previous transaction left off. Writing a 1 to ABT clears this error flag.

SPI Interrupts

When SPI interrupts are enabled, the SPI generates an interrupt after character transmission/reception completes in both master and slave modes. A character can be defined to be



1 through 8 bits by the `NUMBITS` field in the SPI Mode register. In SLAVE mode it is not necessary for `SS` to deassert between characters to generate the interrupt. The SPI in SLAVE mode can also generate an interrupt if the `SS` signal deasserts prior to transfer of all the bits in a character (see description of slave abort error above). Writing a 1 to the `IRQ` bit in the SPI Status Register clears the pending SPI interrupt request. The `IRQ` bit must be cleared to 0 by the Interrupt Service Routine to generate future interrupts. To start the transfer process, an SPI interrupt may be forced by software writing a 1 to the `STR` bit in the `SPICTL` register.

If the SPI is disabled, an SPI interrupt can be generated by a Baud Rate Generator time-out. This timer function must be enabled by setting the `BIRQ` bit in the `SPICTL` register. This Baud Rate Generator time-out does not set the `IRQ` bit in the `SPISTAT` register, just the SPI interrupt bit in the interrupt controller.

SPI Baud Rate Generator

In SPI MASTER mode, the Baud Rate Generator creates a lower frequency serial clock (SCK) for data transmission synchronization between the Master and the external Slave. The input to the Baud Rate Generator is the system clock. The SPI Baud Rate High and Low Byte registers combine to form a 16-bit reload value, `BRG[15:0]`, for the SPI Baud Rate Generator. The SPI baud rate is calculated using the following equation:

$$\text{SPI Baud Rate (bits/s)} = \frac{\text{System Clock Frequency (Hz)}}{2 \times \text{BRG}[15:0]}$$

Minimum baud rate is obtained by setting `BRG[15:0]` to 0000H for a clock divisor value of ($2 \times 65536 = 131072$).

When the SPI is disabled, the Baud Rate Generator can function as a basic 16-bit timer with interrupt on time-out. To configure the Baud Rate Generator as a timer with interrupt on time-out, complete the following procedure:

1. Disable the SPI by clearing the `SP1EN` bit in the SPI Control register to 0.
2. Load the desired 16-bit count value into the SPI Baud Rate High and Low Byte registers.
3. Enable the Baud Rate Generator timer function and associated interrupt by setting the `BIRQ` bit in the SPI Control register to 1.

SPI Control Register Definitions

SPI Data Register

The SPI Data register stores both the outgoing (transmit) data and the incoming (receive) data. Reads from the SPI Data register always return the current contents of the 8-bit shift



register. Data is shifted out starting with bit 7. The last bit received resides in bit position 0.

With the SPI configured as a Master, writing a data byte to this register initiates the data transmission. With the SPI configured as a Slave, writing a data byte to this register loads the shift register in preparation for the next data transfer with the external Master. In either the Master or Slave modes, if a transmission is already in progress, writes to this register are ignored and the Overrun error flag, OVR, is set in the SPI Status register.

When the character length is less than 8 bits (as set by the NUMBITS field in the SPI Mode register), the transmit character must be left justified in the SPI Data register. A received character of less than 8 bits is right justified (last bit received is in bit position 0). For example, if the SPI is configured for 4-bit characters, the transmit characters must be written to SPIDATA[7:4] and the received characters are read from SPIDATA[3:0].

Table 61. SPI Data Register (SPIDATA)

BITS	7	6	5	4	3	2	1	0
FIELD	DATA							
RESET	X	X	X	X	X	X	X	X
R/W	R/W	R/W	R/W	R/W	R/W	R/W	R/W	R/W
ADDR	F60H							

DATA—Data
Transmit and/or receive data.

SPI Control Register

The SPI Control register configures the SPI for transmit and receive operations.

Table 62. SPI Control Register (SPICTL)

BITS	7	6	5	4	3	2	1	0
FIELD	IRQE	STR	BIRQ	PHASE	CLKPOL	WOR	MMEN	SPIEN
RESET	0	0	0	0	0	0	0	0
R/W	R/W	R/W	R/W	R/W	R/W	R/W	R/W	R/W
ADDR	F61H							



IRQE—Interrupt Request Enable

0 = SPI interrupts are disabled. No interrupt requests are sent to the Interrupt Controller.

1 = SPI interrupts are enabled. Interrupt requests are sent to the Interrupt Controller.

STR—Start an SPI Interrupt Request

0 = No effect.

1 = Setting this bit to 1 also sets the $\overline{\text{IRQ}}$ bit in the SPI Status register to 1. Setting this bit forces the SPI to send an interrupt request to the Interrupt Control. This bit can be used by software for a function similar to transmit buffer empty in a UART. Writing a 1 to the $\overline{\text{IRQ}}$ bit in the SPI Status register clears this bit to 0.

BIRQ—BRG Timer Interrupt Request

If the SPI is enabled, this bit has no effect. If the SPI is disabled:

0 = The Baud Rate Generator timer function is disabled.

1 = The Baud Rate Generator timer function and time-out interrupt are enabled.

PHASE—Phase Select

Sets the phase relationship of the data to the clock. Refer to the SPI Clock Phase and Polarity Control section for more information on operation of the PHASE bit.

CLKPOL—Clock Polarity

0 = SCK idles Low (0).

1 = SCK idle High (1).

WOR—Wire-OR (Open-Drain) Mode Enabled

0 = SPI signal pins not configured for open-drain.

1 = All four SPI signal pins (SCK, $\overline{\text{SS}}$, MISO, MOSI) configured for open-drain function. This setting is typically used for multi-master and/or multi-slave configurations.

MMEN—SPI MASTER Mode Enable

0 = SPI configured in SLAVE mode.

1 = SPI configured in MASTER mode.

SPIEN—SPI Enable

0 = SPI disabled.

1 = SPI enabled.

SPI Status Register

The SPI Status register indicates the current state of the SPI. All bits revert to their reset state if the SPIEN bit in the SPICTL register = 0.



Table 63. SPI Status Register (SPISTAT)

BITS	7	6	5	4	3	2	1	0
FIELD	IRQ	OVR	COL	ABT	Reserved		TXST	SLAS
RESET	0	0	0	0	0		0	1
R/W	R/W*	R/W*	R/W*	R/W*	R		R	R
ADDR	F62H							
R/W* = Read access. Write a 1 to clear the bit to 0.								

IRQ—Interrupt Request

If SPIEN = 1, this bit is set if the STR bit in the SPICTL register is set, or upon completion of an SPI master or slave transaction. This bit does not set if SPIEN = 0 and the SPI Baud Rate Generator is used as a timer to generate the SPI interrupt.

0 = No SPI interrupt request pending.

1 = SPI interrupt request is pending.

OVR—Overrun

0 = An overrun error has not occurred.

1 = An overrun error has been detected.

COL—Collision

0 = A multi-master collision (mode fault) has not occurred.

1 = A multi-master collision (mode fault) has been detected.

ABT—SLAVE mode transaction abort

This bit is set if the SPI is configured in SLAVE mode, a transaction is occurring and \overline{SS} deasserts before all bits of a character have been transferred as defined by the NUMBITS field of the SPIMODE register. The IRQ bit also sets, indicating the transaction has completed.

0 = A SLAVE mode transaction abort has not occurred.

1 = A SLAVE mode transaction abort has been detected.

Reserved—Must be 0.

TXST—Transmit Status

0 = No data transmission currently in progress.

1 = Data transmission currently in progress.

SLAS—Slave Select

If SPI enabled as a Slave,

0 = \overline{SS} input pin is asserted (Low)

1 = \overline{SS} input is not asserted (High).

If SPI enabled as a Master, this bit is not applicable.



SPI Mode Register

The SPI Mode register configures the character bit width and the direction and value of the \overline{SS} pin.

Table 64. SPI Mode Register (SPIMODE)

BITS	7	6	5	4	3	2	1	0
FIELD	Reserved		DIAG	NUMBITS[2:0]			SSIO	SSV
RESET	0	0	0	0	0	0	0	0
R/W	R	R/W	R/W	R/W	R/W	R/W	R/W	R/W
ADDR	F63H							

Reserved—Must be 0.

DIAG - Diagnostic Mode Control bit

This bit is for SPI diagnostics. Setting this bit allows the Baud Rate Generator value to be read using the SPIBRH and SPIBRL register locations.

0 = Reading SPIBRH, SPIBRL returns the value in the SPIBRH and SPIBRL registers

1 = Reading SPIBRH returns bits [15:8] of the SPI Baud Rate Generator; and reading SPIBRL returns bits [7:0] of the SPI Baud Rate Counter. The Baud Rate Counter High and Low byte values are not buffered.



Caution: Exercise caution if reading the values while the BRG is counting.

NUMBITS[2:0]—Number of Data Bits Per Character to Transfer

This field contains the number of bits to shift for each character transfer. Refer to the SPI Data Register description for information on valid bit positions when the character length is less than 8-bits.

- 000 = 8 bits
- 001 = 1 bit
- 010 = 2 bits
- 011 = 3 bits
- 100 = 4 bits
- 101 = 5 bits
- 110 = 6 bits
- 111 = 7 bits.

SSIO—Slave Select I/O

0 = \overline{SS} pin configured as an input.

1 = \overline{SS} pin configured as an output (MASTER mode only).



SSV—Slave Select Value

If SSIO = 1 and SPI configured as a Master:

0 = \overline{SS} pin driven Low (0).

1 = \overline{SS} pin driven High (1).

This bit has no effect if SSIO = 0 or SPI configured as a Slave.

SPI Diagnostic State Register

The SPI Diagnostic State register provides observability of internal state. This is a read only register used for SPI diagnostics.

Table 65. SPI Diagnostic State Register (SPIDST)

BITS	7	6	5	4	3	2	1	0
FIELD	SCKEN	TCKEN	SPISTATE					
RESET	0	0	0					
R/W	R	R	R					
ADDR	F64H							

SCKEN - Shift Clock Enable

0 = The internal Shift Clock Enable signal is deasserted

1 = The internal Shift Clock Enable signal is asserted (shift register is updates on next system clock)

TCKEN - Transmit Clock Enable

0 = The internal Transmit Clock Enable signal is deasserted.

1 = The internal Transmit Clock Enable signal is asserted. When this is asserted the serial data out is updated on the next system clock (MOSI or MISO).

SPISTATE - SPI State Machine

Defines the current state of the internal SPI State Machine.



SPI Baud Rate High and Low Byte Registers

The SPI Baud Rate High and Low Byte registers combine to form a 16-bit reload value, BRG[15:0], for the SPI Baud Rate Generator. The SPI baud rate is calculated using the following equation:

$$\text{SPI Baud Rate (bits/s)} = \frac{\text{System Clock Frequency (Hz)}}{2 \times \text{BRG}[15:0]}$$

Minimum baud rate is obtained by setting BRG[15:0] to 0000H for a clock divisor value of (2 X 65536 = 131072).

Table 66. SPI Baud Rate High Byte Register (SPIBRH)

BITS	7	6	5	4	3	2	1	0
FIELD	BRH							
RESET	1	1	1	1	1	1	1	1
R/W	R/W	R/W	R/W	R/W	R/W	R/W	R/W	R/W
ADDR	F66H							

BRH = SPI Baud Rate High Byte
Most significant byte, BRG[15:8], of the SPI Baud Rate Generator's reload value.

Table 67. SPI Baud Rate Low Byte Register (SPIBRL)

BITS	7	6	5	4	3	2	1	0
FIELD	BRL							
RESET	1	1	1	1	1	1	1	1
R/W	R/W	R/W	R/W	R/W	R/W	R/W	R/W	R/w
ADDR	F67H							

BRL = SPI Baud Rate Low Byte
Least significant byte, BRG[7:0], of the SPI Baud Rate Generator's reload value.



I²C Controller

Overview

The I²C Controller makes the Z8F082x family products bus-compatible with the I²C™ protocol. The I²C Controller consists of two bidirectional bus lines—a serial data signal (SDA) and a serial clock signal (SCL). Features of the I²C Controller include:

- Transmit and Receive Operation in MASTER mode
- Maximum data rate of 400kbit/sec
- 7- and 10-bit Addressing Modes for Slaves
- Unrestricted Number of Data Bytes Transmitted per Transfer

The I²C Controller in the Z8F082x family products does not operate in SLAVE mode.

Operation

The I²C Controller operates in MASTER mode to transmit and receive data. Only a single master is supported. Arbitration between two masters must be accomplished in software. I²C supports the following operations:

- Master transmits to a 7-bit slave
- Master transmits to a 10-bit slave
- Master receives from a 7-bit slave
- Master receives from a 10-bit slave

SDA and SCL Signals

I²C sends all addresses, data and acknowledge signals over the SDA line, most-significant bit first. SCL is the common clock for the I²C Controller. When the SDA and SCL pin alternate functions are selected for their respective GPIO ports, the pins are automatically configured for open-drain operation.

The master (I²C) is responsible for driving the SCL clock signal, although the clock signal can become skewed by a slow slave device. During the Low period of the clock, the slave pulls the SCL signal Low to suspend the transaction. The master releases the clock at the end of the Low period and notices that the clock remains Low instead of returning to a



High level. When the slave has released the clock, the I²C Controller continues the transaction. All data is transferred in bytes and there is no limit to the amount of data transferred in one operation. When transmitting data or acknowledging read data from the slave, the SDA signal changes in the middle of the Low period of SCL and is sampled in the middle of the high period of SCL.

I²C Interrupts

The I²C Controller contains four sources of interrupts—Transmit, Receive, Not Acknowledge (NAK) and baud rate generator. These four interrupt sources are combined into a single interrupt request signal to the interrupt controller.

NAK interrupts occur when a Not Acknowledge is received from the slave or sent by the I²C Controller and the Start or Stop bit is not set. The NAK event sets bit 0 of the I2CSTAT register and can only be cleared by setting the `start` or `stop` bit. When this interrupt occurs, the I²C Controller waits until it is cleared before performing any action. In an interrupt service routine, the NAK interrupt must be the first item polled.

Receive interrupts occur when a byte of data has been received by the I²C master. The receive interrupt is cleared by reading from the I²C Data register. If no action is taken, the I²C Controller waits until this interrupt is cleared before performing any other action.

For Transmit interrupts to occur, the `TXI` bit must be 1 in the I²C Control register. Transmit interrupts occur under the following conditions when the transmit data register is empty:

- The I²C Controller is enabled
- The first bit of the byte of an address is shifting out and the `RD` bit of the I²C Status register is deasserted
- The first bit of a 10-bit address shifts out
- The first bit of write data shifted out

► **Note:** Writing to the I²C Data register always clears the `TRDE` bit to 0.

The fourth interrupt source is the baud rate generator. If the I²C Controller is disabled (`IEN` bit in the `I2CCTL` register = 0) and the `BIRQ` bit in the `I2CCTL` register = 1, an interrupt is generated when the baud rate generator counts down to 1.

Start and Stop Conditions

The master (I²C) drives all Start and Stop signals and initiates all transactions. To start a transaction, the I²C Controller generates a `START` condition by pulling the SDA signal low while SCL is High. To complete a transaction, the I²C Controller generates a `Stop` condition by creating a Low-to-High transition of the SDA signal while the SCL signal is High. The Start and Stop signals are found in the I²C Control register and must be written by software when the Z8F082x family device must begin or end a transaction.

Write Transaction with a 7-Bit Address

Figure 25 illustrates the data transfer format for a 7-bit addressed slave. Shaded regions indicate data transferred from the I²C Controller to slaves and unshaded regions indicate data transferred from the slaves to the I²C Controller.



Figure 25. 7-Bit Addressed Slave Data Transfer Format

The procedure for a transmit operation on a 7-bit addressed slave is as follows:

1. Software asserts the IEN bit in the I²C Control register.
2. Software asserts the TXI bit of the I²C Control register to enable Transmit interrupts.
3. The I²C interrupt asserts, because the I²C Data register is empty
4. Software responds to the TDRE bit by writing a 7-bit slave address plus write bit (=0) to the I²C Data register.
5. Software asserts the START bit of the I²C Control register.
6. The I²C Controller sends the START condition to the I²C slave.
7. The I²C Controller loads the I²C Shift register with the contents of the I²C Data register.
8. After one bit of address has been shifted out by the SDA signal, the Transmit interrupt is asserted.
9. Software responds by writing the transmit data into the I²C Data register.
10. The I²C Controller shifts the rest of the address and write bit out by the SDA signal.
11. The I²C slave sends an acknowledge (by pulling the SDA signal Low) during the next high period of SCL. The I²C Controller sets the ACK bit in the I²C Status register.
12. The I²C Controller loads the contents of the I²C Shift register with the contents of the I²C Data register.
13. The I²C Controller shifts the data out of via the SDA signal. After the first bit is sent, the Transmit interrupt is asserted.
14. If more bytes remain to be sent, return to step 9
15. Software responds by setting the STOP bit of the I²C Control register (or START bit to initiate a new transaction).
16. If no new data is to be sent or address is to be sent, software responds by clearing the TXI bit of the I²C Control register.

17. The I²C Controller completes transmission of the data on the SDA signal.
18. The I²C Controller sends the STOP condition to the I²C bus.

Write Transaction with a 10-Bit Address

Figure 26 illustrates the data transfer format for a 10-bit addressed slave. Shaded regions indicate data transferred from the I²C Controller to slaves and unshaded regions indicate data transferred from the slaves to the I²C Controller.

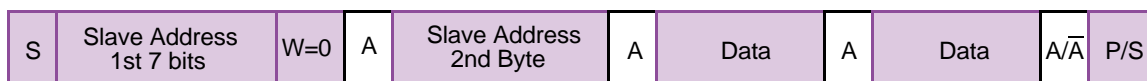

Figure 26. 10-Bit Addressed Slave Data Transfer Format

The first seven bits transmitted in the first byte are 11110XX. The two bits XX are the two most-significant bits of the 10-bit address. The lowest bit of the first byte transferred is the read/write control bit (=0). The transmit operation is carried out in the same manner as 7-bit addressing.

The procedure for a transmit operation on a 10-bit addressed slave is as follows:

1. Software asserts the IEN bit in the I²C Control register.
2. Software asserts the TXI bit of the I²C Control register to enable Transmit interrupts.
3. The I²C interrupt asserts because the I²C Data register is empty.
4. Software responds to the TDRE interrupt by writing the first slave address byte. The least-significant bit must be 0 for the write operation.
5. Software asserts the START bit of the I²C Control register.
6. The I²C Controller sends the START condition to the I²C slave.
7. The I²C Controller loads the I²C Shift register with the contents of the I²C Data register.
8. After one bit of address is shifted out by the SDA signal, the Transmit interrupt is asserted.
9. Software responds by writing the second byte of address into the contents of the I²C Data register.
10. The I²C Controller shifts the rest of the first byte of address and write bit out the SDA signal.
11. The I²C slave sends an acknowledge by pulling the SDA signal Low during the next high period of SCL. The I²C Controller sets the ACK bit in the I²C Status register.
12. The I²C Controller loads the I²C Shift register with the contents of the I²C Data register.



13. The I²C Controller shifts the second address byte out the SDA signal. After the first bit has been sent, the Transmit interrupt is asserted.
14. Software responds by writing the data to be written out to the I²C Control register.
15. The I²C Controller shifts out the rest of the second byte of slave address by the SDA signal.
16. The I²C slave sends an acknowledge by pulling the SDA signal Low during the next High period of SCL. The I²C Controller sets the ACK bit in the I²C Status register.
17. The I²C Controller shifts the data out by the SDA signal. After the first bit is sent, the Transmit interrupt is asserted.
18. Software responds by asserting the STOP bit of the I²C Control register.
19. The I²C Controller completes transmission of the data on the SDA signal.
20. The I²C Controller sends the STOP condition to the I²C bus.

Read Transaction with a 7-Bit Address

Figure 27 illustrates the data transfer format for a read operation to a 7-bit addressed slave. The shaded regions indicate data transferred from the I²C Controller to slaves and unshaded regions indicate data transferred from the slaves to the I²C Controller.

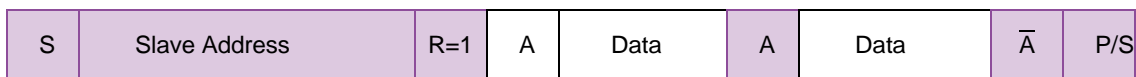

Figure 27. Receive Data Transfer Format for a 7-Bit Addressed Slave

The procedure for a read operation to a 7-bit addressed slave is as follows:

1. Software writes the I²C Data register with a 7-bit slave address plus the read bit (=1).
2. Software asserts the START bit of the I²C Control register.
3. If this is a single byte transfer, Software asserts the NAK bit of the I²C Control register so that after the first byte of data has been read by the I²C Controller, a Not Acknowledge is sent to the I²C slave.
4. The I²C Controller sends the START condition.
5. The I²C Controller sends the address and read bit out the SDA signal.
6. The I²C slave acknowledges the address by pulling the SDA signal Low during the next High period of SCL.
7. The I²C Controller shifts in the first byte of data from the I²C slave on the SDA signal.
8. The I²C Controller asserts the Receive interrupt.

9. Software responds by reading the I²C Data register.
10. The I²C Controller sends a NAK to the I²C slave (if this is the last byte).
11. If there are more bytes to transfer, return to step 7.
12. A NAK interrupt is generated by the I²C Controller.
13. Software responds by setting the STOP bit of the I²C Control register.
14. A STOP condition is sent to the I²C slave.

Read Transaction with a 10-Bit Address

Figure 28 illustrates the read transaction format for a 10-bit addressed slave. The shaded regions indicate data transferred from the I²C Controller to slaves and unshaded regions indicate data transferred from the slaves to the I²C Controller.

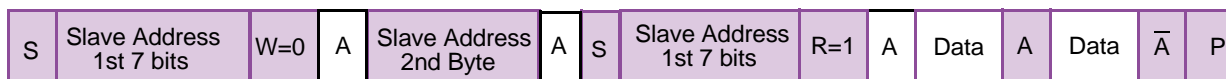

Figure 28. Receive Data Format for a 10-Bit Addressed Slave

The first seven bits transmitted in the first byte are 11110XX. The two bits XX are the two most-significant bits of the 10-bit address. The lowest bit of the first byte transferred is the write control bit.

The data transfer procedure for a read operation to a 10-bit addressed slave is as follows:

1. Software writes 11110B followed by the two address bits and a 0 (write) to the I²C Data register.
2. Software asserts the START bit of the I²C Control register.
3. The I²C Controller sends the Start condition.
4. The I²C Controller loads the I²C Shift register with the contents of the I²C Data register.
5. After the first bit has been shifted out, a Transmit interrupt is asserted.
6. Software responds by writing eight bits of address to the I²C Data register.
7. The I²C Controller completes shifting of the two address bits and a 0 (write).
8. The I²C slave sends an acknowledge by pulling the SDA signal Low during the next High period of SCL.
9. The I²C Controller loads the I²C Shift register with the contents of the I²C Data register (lower byte of 10 bit address).



10. The I²C Controller shifts out the next eight bits of address. After the first bit is shifted, the I²C Controller generates a Transmit interrupt.
11. Software responds by setting the START bit of the I²C Control register to generate a repeated START.
12. Software responds by writing 11110B followed by the 2-bit slave address and a 1 (read) to the I²C Data register.
13. If you want to read only one byte, software responds by setting the NAK bit of the I²C Control register.
14. After the I²C Controller shifts out the address bits mentioned in step 9 (2nd address transfer), the I²C slave sends an acknowledge by pulling the SDA signal Low during the next high period of SCL.
15. The I²C Controller sends the repeated START condition.
16. The I²C Controller loads the I²C Shift register with the contents of the I²C Data register (third address transfer).
17. The I²C Controller sends 11110B followed by the two most significant bits of the slave read address and a 1 (read).
18. The I²C slave sends an acknowledge by pulling the SDA signal Low during the next high period of SCL.
19. The I²C Controller shifts in a byte of data from the slave.
20. A Receive interrupt is generated.
21. Software responds by reading the I²C Data register.
22. Software responds by setting the STOP bit of the I²C Control register.
23. A NAK condition is sent to the I²C slave.
24. A STOP condition is sent to the I²C slave.

I²C Control Register Definitions

I²C Data Register

The I²C Data register holds the data that is to be loaded into the I²C Shift register during a write to a slave. This register also holds data that is loaded from the I²C Shift register dur-



ing a read from a slave. The I²C Shift Register is not accessible in the Register File address space, but only buffers incoming and outgoing data.

Table 68. I²C Data Register (I2CDATA)

BITS	7	6	5	4	3	2	1	0
FIELD	DATA							
RESET	0	0	0	0	0	0	0	0
R/W	R/W	R/W	R/W	R/W	R/W	R/W	R/W	R/W
ADDR	F50H							

I²C Status Register

The Read-only I²C Status register indicates the status of the I²C Controller.

Table 69. I²C Status Register (I2CSTAT)

BITS	7	6	5	4	3	2	1	0
FIELD	TDRE	RDRF	ACK	10B	RD	TAS	DSS	NCKI
RESET	1	0	0	0	0	0	0	0
R/W	R	R	R	R	R	R	R	R
ADDR	F51H							

TDRE—Transmit Data Register Empty

When the I²C Controller is enabled, this bit is 1 when the I²C Data register is empty. When active, this bit causes the I²C Controller to generate an interrupt, except when the I²C Controller is shifting in data during the reception of a byte or when shifting an address and the RD bit is set. Writing to the I²C DATA register clears this bit and the interrupt.

RDRF—Receive Data Register Full

This bit is set = 1 when the I²C Controller is enabled and the I²C Controller has received a byte of data. When asserted, this bit causes the I²C Controller to generate an interrupt. Reading the I²C Data register clears this bit.

ACK—Acknowledge

This bit indicates the status of the Acknowledge for the last byte transmitted or received. When set, this bit indicates that an Acknowledge was received for the last byte transmitted or received.



10B—10-Bit Address

This bit indicates whether a 10- or 7-bit address is being transmitted. After the START bit is set, if the five most-significant bits of the address are 11110B, this bit is set. When set, it is reset once the first byte of the address has been sent.

RD—Read

This bit indicates the direction of transfer of the data. It is active high during a read. The status of this bit is determined by the least-significant bit of the I²C Shift register after the START bit is set.

TAS—Transmit Address State

This bit is active high while the address is being shifted out of the I²C Shift register.

DSS—Data Shift State

This bit is active high while data is being shifted to or from the I²C Shift register.

NCKI—NACK Interrupt

This bit is set high when a Not Acknowledge condition is received or sent and neither the START nor the STOP bit is active. When set, this bit generates an interrupt that can only be cleared by setting the START or STOP bit, allowing the user to specify whether he wants to perform a STOP or a repeated START.

I²C Control Register

The I²C Control register enables the I²C operation.

Table 70. I²C Control Register (I2CCTL)

BITS	7	6	5	4	3	2	1	0
FIELD	IEN	START	STOP	BIRQ	TXI	NAK	FLUSH	FILTEN
RESET	0	0	0	0	0	0	0	0
R/W	R/W	R/W	R/W	R/W	R/W	R/W	R/W	R/W
ADDR	F52H							

IEN—I²C Enable

This bit enables the I²C transmitter and receiver.

START—Send Start Condition

This bit sends the Start condition. Once asserted, it is cleared by the I²C Controller after it sends the START condition or by deasserting the IEN bit. If this bit is 1, it cannot be cleared to 0 by writing to the register. After this bit is set, the Start condition is sent if there is data in the I²C Data or I²C Shift register. If there is no data in one of these registers, the I²C Controller waits until data is loaded. If this bit is set while the I²C Controller is shifting out data, it generates a START condition after the byte shifts and the acknowledge



phase completes. If the STOP bit is also set, it also waits until the STOP condition is sent before the START condition.

STOP—Send Stop Condition

This bit causes the I²C Controller to issue a Stop condition after the byte in the I²C Shift register has completed transmission or after a byte has been received in a receive operation. Once set, this bit is reset by the I²C Controller after a Stop condition has been sent or by deasserting the IEN bit. If this bit is 1, it cannot be cleared to 0 by writing to the register.

BIRQ—Baud Rate Generator Interrupt Request

This bit causes an interrupt to occur every time the baud rate generator counts down to one. This bit allows the I²C Controller to be used as an additional timer when the I²C Controller is disabled. This bit is ignored when the I²C Controller is enabled.

TXI—Enable TDRE interrupts

This bit enables interrupts when the I²C Data register is empty on the I²C Controller.

NAK—Send NAK

This bit sends a Not Acknowledge condition after the next byte of data has been read from the I²C slave. Once asserted, it is deasserted after a Not Acknowledge is sent or the IEN bit is deasserted.

FLUSH—Flush Data

Setting this bit to 1 clears the I²C Data register and sets the TDRE bit to 1. This bit allows flushing of the I²C Data register when an NAK is received after the data has been sent to the I²C Data register. Reading this bit always returns 0.

FILTEN—I²C Signal Filter Enable

Setting this bit to 1 enables low-pass digital filters on the SDA and SCL input signals. These filters reject any input pulse with periods less than a full system clock cycle. The filters introduce a 3-system clock cycle latency on the inputs.

I²C Baud Rate High and Low Byte Registers

The I²C Baud Rate High and Low Byte registers combine to form a 16-bit reload value, BRG[15:0], for the I²C Baud Rate Generator. The I²C baud rate is calculated using the following equation (note if BRG = 0x0000, use 0x10000 in the equation):

$$\text{I}^2\text{C Baud Rate (bits/s)} = \frac{\text{System Clock Frequency (Hz)}}{4 \times \text{BRG}[15:0]}$$



Table 71. I²C Baud Rate High Byte Register (I2CBRH)

BITS	7	6	5	4	3	2	1	0
FIELD	BRH							
RESET	1	1	1	1	1	1	1	1
R/W	R/W	R/W	R/W	R/W	R/W	R/W	R/W	R/W
ADDR	F53H							

BRH = I²C Baud Rate High Byte
Most significant byte, BRG[15:8], of the I²C Baud Rate Generator's reload value.

If the DIAG bit in the I²C Diagnostic Control Register is set to 1, a read of the I2CBRH register returns the current value of the I²C Baud Rate Counter[15:8].

Table 72. I²C Baud Rate Low Byte Register (I2CBRL)

BITS	7	6	5	4	3	2	1	0
FIELD	BRL							
RESET	1	1	1	1	1	1	1	1
R/W	R/W	R/W	R/W	R/W	R/W	R/W	R/W	R/W
ADDR	F54H							

BRL = I²C Baud Rate Low Byte
Least significant byte, BRG[7:0], of the I²C Baud Rate Generator's reload value.

► **Note:** If the DIAG bit in the I²C Diagnostic Control Register is set to 1, a read of the I2CBRL register returns the current value of the I²C Baud Rate Counter[7:0].



I²C Diagnostic State Register

The I²C Diagnostic State Register provides observability of internal state. This is a read only register used for I²C diagnostics.

Table 73. I²C Diagnostic State Register (I2CDST)

BITS	7	6	5	4	3	2	1	0
FIELD	SCLIN	SDAIN	STPCNT	TXRXSTATE				
RESET	X	X	0	00000				
R/W	R	R	R	R				
ADDR	F55H							

SCLIN - Value of Serial Clock input signal

SDAIN - Value of the Serial Data input signal

STPCNT - Value of the internal Stop Count control signal

TXRXSTATE - Value of the I²C state machine

I²C Diagnostic Control Register

The I²C Diagnostic Register provides control over diagnostic modes. This is a read/write register used for I²C diagnostics.

Table 74. I²C Diagnostic Control Register (I2CDIAG)

BITS	7	6	5	4	3	2	1	0
FIELD	Reserved							DIAG
RESET	0	0	0	0	0	0	0	0
R/W	R	R	R	R	R	R	R	R/W
ADDR	F56H							

DIAG = Diagnostic Control Bit - Selects read back value of the Baud Rate Reload registers. In diagnostic mode the Baud Rate Counter may be read back.

0 = Normal mode

1 = Diagnostic mode



Analog-to-Digital Converter

Overview

The Analog-to-Digital Converter (ADC) converts an analog input signal to a 10-bit binary number. The features of the sigma-delta ADC include:

- Five analog input sources are multiplexed with general-purpose I/O ports
- Interrupt upon conversion complete
- Internal voltage reference generator

The ADC is only available in the Z8F0822, Z8F0821, Z8F0422 and Z8F0421.

Architecture

Figure 29 illustrates the three major functional blocks (converter, analog multiplexer, and voltage reference generator) of the ADC. The ADC converts an analog input signal to its digital representation. The 5-input analog multiplexer selects one of the 5 analog input sources. The ADC requires an input reference voltage for the conversion. The voltage reference for the conversion may be input through the external VREF pin or generated internally by the voltage reference generator.

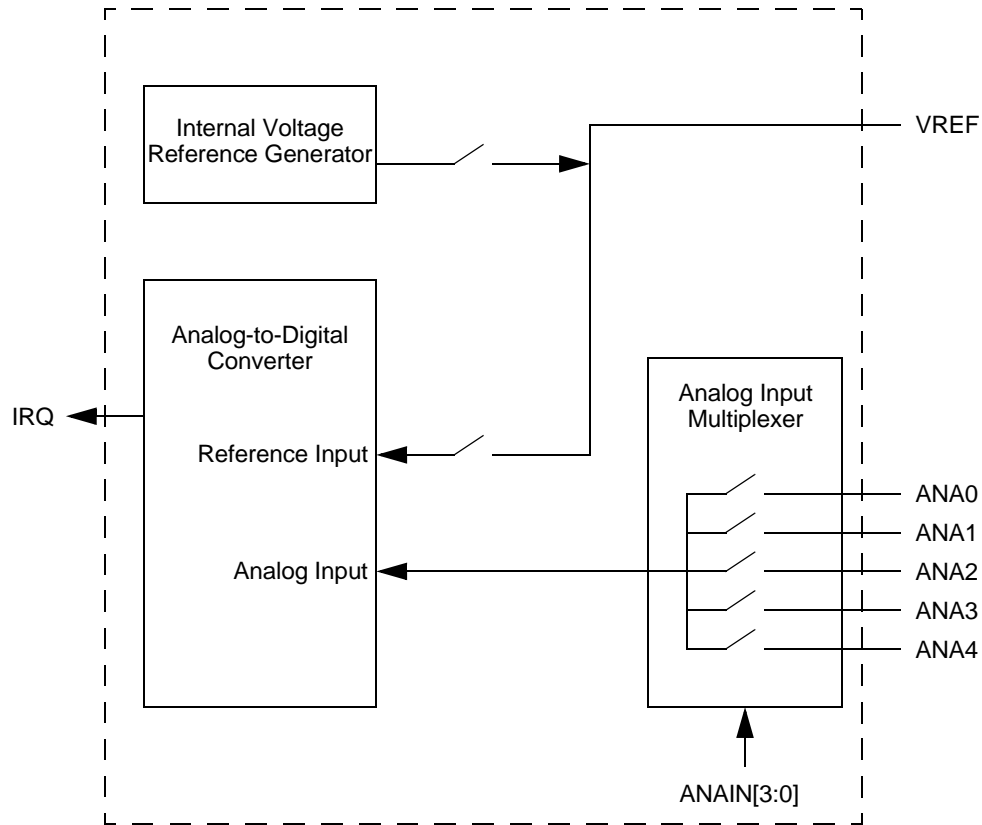

Figure 29. Analog-to-Digital Converter Block Diagram

Operation

Automatic Power-Down

If the ADC is idle (no conversions in progress) for 160 consecutive system clock cycles, portions of the ADC are automatically powered-down. From this power-down state, the ADC requires 40 system clock cycles to power-up. The ADC powers up when a conversion is requested using the ADC Control register.

Single-Shot Conversion

When configured for single-shot conversion, the ADC performs a single analog-to-digital conversion on the selected analog input channel. After completion of the conversion, the ADC shuts down. The steps for setting up the ADC and initiating a single-shot conversion are as follows:

1. Enable the desired analog inputs by configuring the general-purpose I/O pins for alternate function. This configuration disables the digital input and output drivers.
2. Write to the ADC Control register to configure the ADC and begin the conversion. The bit fields in the ADC Control register can be written simultaneously:
 - Write to the ANAIN [3 : 0] field to select one of the 5 analog input sources.
 - Clear CONT to 0 to select a single-shot conversion.
 - Write to the $\overline{\text{VREF}}$ bit to enable or disable the internal voltage reference generator.
 - Set CEN to 1 to start the conversion.
3. CEN remains 1 while the conversion is in progress. A single-shot conversion requires 5129 system clock cycles to complete. If a single-shot conversion is requested from an ADC powered-down state, the ADC uses 40 additional clock cycles to power-up before beginning the 5129 cycle conversion.
4. When the conversion is complete, the ADC control logic performs the following operations:
 - 10-bit data result written to {ADCDH[7:0], ADCDL[7:6]}.
 - CEN resets to 0 to indicate the conversion is complete.
 - An interrupt request is sent to the Interrupt Controller.
5. If the ADC remains idle for 160 consecutive system clock cycles, it is automatically powered-down.

Continuous Conversion

When configured for continuous conversion, the ADC continuously performs an analog-to-digital conversion on the selected analog input. Each new data value over-writes the previous value stored in the ADC Data registers. An interrupt is generated after each conversion.



Caution:

In CONTINUOUS mode, users must be aware that ADC updates are limited by the input signal bandwidth of the ADC and the latency of the ADC and its digital filter. Step changes at the input are not seen at the next output from the ADC. The response of the ADC (in all modes) is limited by the input signal bandwidth and the latency.

The steps for setting up the ADC and initiating continuous conversion are as follows:

1. Enable the desired analog input by configuring the general-purpose I/O pins for alternate function. This disables the digital input and output driver.
2. Write to the ADC Control register to configure the ADC for continuous conversion. The bit fields in the ADC Control register may be written simultaneously:
 - Write to the ANAIN [3 : 0] field to select one of the 5 analog input sources.



- Set CONT to 1 to select continuous conversion.
 - Write to the $\overline{\text{VREF}}$ bit to enable or disable the internal voltage reference generator.
 - Set CEN to 1 to start the conversions.
3. When the first conversion in continuous operation is complete (after 5129 system clock cycles, plus the 40 cycles for power-up, if necessary), the ADC control logic performs the following operations:
 - CEN resets to 0 to indicate the first conversion is complete. CEN remains 0 for all subsequent conversions in continuous operation.
 - An interrupt request is sent to the Interrupt Controller to indicate the conversion is complete.
 4. Thereafter, the ADC writes a new 10-bit data result to {ADCDH[7:0], ADCDL[7:6]} every 256 system clock cycles. An interrupt request is sent to the Interrupt Controller when each conversion is complete.
 5. To disable continuous conversion, clear the CONT bit in the ADC Control register to 0.

ADC Control Register Definitions

ADC Control Register

The ADC Control register selects the analog input channel and initiates the analog-to-digital conversion.

Table 75. ADC Control Register (ADCCTL)

BITS	7	6	5	4	3	2	1	0
FIELD	CEN	Reserved	$\overline{\text{VREF}}$	CONT	ANAIN[3:0]			
RESET	0	0	1	0	0000			
R/W	R/W	R/W	R/W	R/W	R/W			
ADDR	F70H							

CEN—Conversion Enable

0 = Conversion is complete. Writing a 0 produces no effect. The ADC automatically clears this bit to 0 when a conversion has been completed.

1 = Begin conversion. Writing a 1 to this bit starts a conversion. If a conversion is already in progress, the conversion restarts. This bit remains 1 until the conversion is complete.

Reserved—Must be 0.



$\overline{\text{VREF}}$

0 = Internal reference generator enabled. The $\overline{\text{VREF}}$ pin should be left unconnected or capacitively coupled to analog ground (AVSS).

1 = Internal voltage reference generator disabled. An external voltage reference must be provided through the $\overline{\text{VREF}}$ pin.

CONT

0 = Single-shot conversion. ADC data is output once at completion of the 5129 system clock cycles.

1 = Continuous conversion. ADC data updated every 256 system clock cycles.

ANAIN—Analog Input Select

These bits select the analog input for conversion. Not all Port pins in this list are available in all packages for the Z8F082x family of products. Refer to the Signal and Pin Descriptions chapter for information regarding the Port pins available with each package style. Do not enable unavailable analog inputs.

- 0000 = ANA0
- 0001 = ANA1
- 0010 = ANA2
- 0011 = ANA3
- 0100 = ANA4
- 0101 = Reserved.
- 011X = Reserved.
- 1XXX = Reserved.

ADC Data High Byte Register

The ADC Data High Byte register contains the upper eight bits of the 10-bit ADC output. During a single-shot conversion, this value is invalid. Access to the ADC Data High Byte register is read-only. The full 10-bit ADC result is given by {ADCDH[7:0], ADCDL[7:6]}. Reading the ADC Data High Byte register latches data in the ADC Low Bits register.

Table 76. ADC Data High Byte Register (ADCDH)

BITS	7	6	5	4	3	2	1	0
FIELD	ADCDH							
RESET	X							
R/W	R							
ADDR	F72H							

ADCDH—ADC Data High Byte

This byte contains the upper eight bits of the 10-bit ADC output. These bits are not valid



during a single-shot conversion. During a continuous conversion, the last conversion output is held in this register. These bits are undefined after a Reset.

ADC Data Low Bits Register

The ADC Data Low Bits register contains the lower two bits of the conversion value. The data in the ADC Data Low Bits register is latched each time the ADC Data High Byte register is read. Reading this register always returns the lower two bits of the conversion last read into the ADC High Byte register. Access to the ADC Data Low Bits register is read-only. The full 10-bit ADC result is given by {ADCDH[7:0], ADCDL[7:6]}.

Table 77. ADC Data Low Bits Register (ADCDL)

BITS	7	6	5	4	3	2	1	0
FIELD	ADCDL		Reserved					
RESET	X		X					
R/W	R		R					
ADDR	F73H							

ADCDL—ADC Data Low Bits

These are the least significant two bits of the 10-bit ADC output. These bits are undefined after a Reset.

Reserved

These bits are reserved and are always undefined.



Flash Memory

Overview

The products in the Z8F082x family feature either 4KB (4096) or 8KB (8192 bytes) of non-volatile Flash memory with read/write/erase capability. The Flash memory can be programmed and erased in-circuit by either user code or through the On-Chip Debugger.

The Flash memory array is arranged in 512-byte per page. The 512-byte page is the minimum Flash block size that can be erased. The Flash memory is also divided into 8 sectors which can be protected from programming and erase operations on a per sector basis.

Table 78 describes the Flash memory configuration for each device in the Z8F082x family. Table 79 lists the sector address ranges. Figure 30 illustrates the Flash memory arrangement.

Table 78. Flash Memory Configurations

Part Number	Flash Size	Number of Pages	Program Memory Addresses	Sector Size	Number of Sectors	Pages per Sector
Z8F04xx	4KB (4096)	8	0000H - 0FFFH	0.5KB (512)	8	1
Z8F08xx	8KB (8192)	16	0000H - 1FFFH	1KB (1024)	8	2

Table 79. Flash Memory Sector Addresses

Sector Number	Flash Sector Address Ranges	
	Z8F04xx	Z8F08xx
0	0000H-01FFH	0000H-03FFH
1	0200H-03FFH	0400H-07FFH
2	0400H-05FFH	0800H-0BFFH
3	0600H-07FFH	0C00H-0FFFH
4	0800H-09FFH	1000H-13FFH
5	0A00H-0BFFH	1400H-17FFH
6	0C00H-0DFFH	1800H-1BFFH
7	0E00H-0FFFH	1C00H-1FFFH

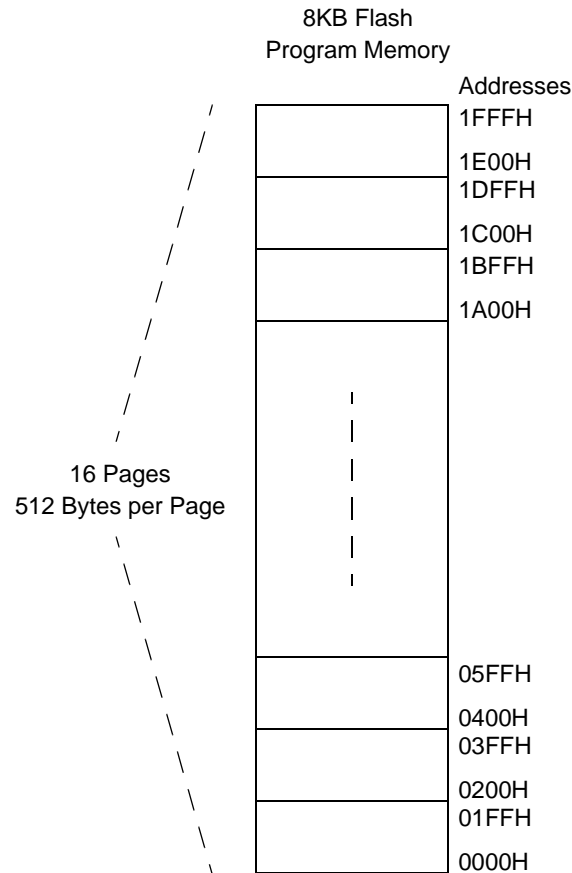

Figure 30. Flash Memory Arrangement

Information Area

Table 80 describes the Z8F082x family Information Area. This 512-byte Information Area is accessed by setting bit 7 of the Flash Page Select Register to 1. When access is enabled, the Information Area is mapped into Program Memory and overlays the 512 bytes at addresses FE00H to FFFFH. When the Information Area access is enabled, LDC instructions return data from the Information Area. CPU instruction fetches always comes from

Program Memory regardless of the Information Area access bit. Access to the Information Area is read-only.

Table 80. Z8F082x family Information Area Map

Program Memory Address (Hex)	Function
FE00H-FE3FH	Reserved
FE40H-FE53H	Part Number 20-character ASCII alphanumeric code Left justified and filled with zeros
FE54H-FFFFH	Reserved

Operation

The Flash Controller provides the proper signals and timing for Byte Programming, Page Erase, and Mass Erase of the Flash memory. The Flash Controller contains a protection mechanism, via the Flash Control register (FCTL), to prevent accidental programming or erasure. The following subsections provide details on the various operations (Lock, Unlock, Sector Protect, Byte Programming, Page Erase, and Mass Erase).

Timing Using the Flash Frequency Registers

Before performing a program or erase operation on the Flash memory, the user must first configure the Flash Frequency High and Low Byte registers. The Flash Frequency registers allow programming and erasure of the Flash with system clock frequencies ranging from 20kHz through 20MHz (the valid range is limited to the device operating frequencies).

The Flash Frequency High and Low Byte registers combine to form a 16-bit value, FFREQ, to control timing for Flash program and erase operations. The 16-bit Flash Frequency value must contain the system clock frequency in kHz. This value is calculated using the following equation:

$$\text{FFREQ}[15:0] = \frac{\text{System Clock Frequency (Hz)}}{1000}$$



Caution:

Flash programming and erasure are not supported for system clock frequencies below 20kHz, above 20MHz, or outside of the device operating frequency range. The Flash Frequency High and Low Byte registers must be loaded with the correct value to insure proper Flash programming and erase operations.



Flash Read Protection

The user code contained within the Flash memory can be protected from external access. Programming the Flash Read Protect Option Bit prevents reading of user code by the On-Chip Debugger or by using the Flash Controller Bypass mode. Refer to the **Option Bits** chapter and the **On-Chip Debugger** chapter for more information.

Flash Write/Erase Protection

The Z8F082x family provides several levels of protection against accidental program and erasure of the Flash memory contents. This protection is provided by the Flash Controller unlock mechanism, the Flash Sector Protect register, and the Flash Write Protect option bit.

Flash Controller Unlock Mechanism

At Reset, the Flash Controller locks to prevent accidental program or erasure of the Flash memory. To program or erase the Flash memory, the Flash controller must be unlocked. After unlocking the Flash Controller, the Flash can be programmed or erased. Any value written by user code to the Flash Control register or Flash Page Select Register out of sequence will lock the Flash Controller.

The proper steps to unlock the Flash Controller from user code are:

1. Write 00H to the Flash Control register to reset the Flash Controller.
2. Write the page to be programmed or erased to the Flash Page Select register.
3. Write the first unlock command 73H to the Flash Control register.
4. Write the second unlock command 8CH to the Flash Control register.
5. Re-write the page written in step 2 to the Flash Page Select register.

Flash Sector Protection

The Flash Sector Protect register can be configured to prevent sectors from being programmed or erased. Once a sector is protected, it cannot be unprotected by user code. The Flash Sector Protect register will be cleared after reset and any previously written protection values will be lost. User code should write this register in their initialization routine if they want to enable sector protection.

The Flash Sector Protect register shares its Register File address with the Flash Page Select register. The Flash Sector Protect register is accessed by writing the Flash Control register with 5EH. Once the Flash Sector Protect register is selected, it can be accessed at the Flash Page Select Register address. When user code writes the Flash Sector Protect register, bits can only be set to 1. Thus, sectors can be protected, but not unprotected, via register write operations. Writing a value other than 5EH to the Flash Control register will de-select the Flash Sector Protect register and re-enable access to the Flash Page Select register.

The proper steps to setup the Flash Sector Protect register from user code are:

1. Write 00H to the Flash Control register to reset the Flash Controller.
2. Write 5EH to the Flash Control register to select the Flash Sector Protect register.
3. Read and/or write the Flash Sector Protect register which is now at Register File address FF9H.
4. Write 00H to the Flash Control register to return the Flash Controller to its reset state.

Flash Write Protection Option Bit

The Flash Write Protect option bit can be enabled to block all program and erase operations from user code. Refer to the **Option Bits** chapter for more information.

Byte Programming

When the Flash Controller is unlocked, writes to Program Memory from user code will program a byte into the Flash if the address is located in the unlocked page. An erased Flash byte contains all ones (FFH). The programming operation can only be used to change bits from one to zero. To change a Flash bit (or multiple bits) from zero to one requires a Page Erase or Mass Erase operation.

Byte Programming can be accomplished using the eZ8 CPU's LDC or LDCI instructions. Refer to the **eZ8 CPU User Manual** for a description of the LDC and LDCI instructions.

While the Flash Controller programs the Flash memory, the eZ8 CPU idles but the system clock and on-chip peripherals continue to operate. Interrupts that occur when a Programming operation is in progress will be serviced once the Programming operation is complete. To exit Programming mode and lock the Flash Controller, write 00H to the Flash Control register.

User code cannot program Flash Memory on a page that lies in a protected sector. When user code writes memory locations, only addresses located in the unlocked page will be programmed. Memory writes outside of the unlocked page are ignored.



Caution: Each memory location should not be programmed more than twice before an erase occurs.

The proper steps to program the Flash from user code are:

1. Write 00H to the Flash Control register to reset the Flash Controller.
2. Write the page of memory to be programmed to the Flash Page Select register.
3. Write the first unlock command 73H to the Flash Control register.
4. Write the second unlock command 8CH to the Flash Control register.
5. Re-write the page written in step 2 to the Flash Page Select register.



6. Write Program Memory using LDC or LDCI instructions to program the Flash.
7. Repeat step 6 to program additional memory locations on the same page.
8. Write 00H to the Flash Control register to lock the Flash Controller.

Page Erase

The Flash memory can be erased one page (512 bytes) at a time. Page Erasing the Flash memory sets all bytes in that page to the value FFH. The Flash Page Select register identifies the page to be erased. While the Flash Controller executes the Page Erase operation, the eZ8 CPU idles but the system clock and on-chip peripherals continue to operate. The eZ8 CPU resumes operation after the Page Erase operation completes. Interrupts that occur when the Page Erase operation is in progress will be serviced once the Page Erase operation is complete. When the Page Erase operation is complete, the Flash Controller returns to its locked state. Only pages located in unprotected sectors can be erased.

The proper steps to perform a Page Erase operation are:

1. Write 00H to the Flash Control register to reset the Flash Controller.
2. Write the page to be erased to the Flash Page Select register.
3. Write the first unlock command 73H to the Flash Control register.
4. Write the second unlock command 8CH to the Flash Control register.
5. Re-write the page written in step 2 to the Flash Page Select register.
6. Write the Page Erase command 95H to the Flash Control register.

Mass Erase

The Flash memory cannot be Mass Erased by user code.

Flash Controller Bypass

The Flash Controller can be bypassed and the control signals for the Flash memory brought out to the GPIO pins. Bypassing the Flash Controller allows faster Programming algorithms by controlling the Flash programming signals directly.

Flash Controller Bypass is recommended for gang programming applications and large volume customers who do not require in-circuit programming of the Flash memory.

Please refer to the document entitled *Third-Party Flash Programming Support for Z8 Encore!™* for more information on bypassing the Flash Controller. This document is available for download at www.zilog.com.



Flash Controller Behavior in Debug Mode

The following changes in behavior of the Flash Controller occur when the Flash Controller is accessed using the On-Chip Debugger:

- The Flash Write Protect option bit is ignored.
- The Flash Sector Protect register is ignored for programming and erase operations.
- Programming operations are not limited to the page selected in the Flash Page Select register.
- Bits in the Flash Sector Protect register can be written to one or zero.
- The second write of the Flash Page Select register to unlock the Flash Controller is not necessary.
- The Flash Page Select register can be written when the Flash Controller is unlocked.
- The Mass Erase command is enabled.

Flash Control Register Definitions

Flash Control Register

The Flash Control register is used to unlock the Flash Controller for programming and erase operations, or to select the Flash Sector Protect register. The Write-only Flash Control Register shares its Register File address with the Read-only Flash Status Register.

Table 81. Flash Control Register (FCTL)

BITS	7	6	5	4	3	2	1	0
FIELD	FCMD							
RESET	0	0	0	0	0	0	0	0
R/W	W	W	W	W	W	W	W	W
ADDR	FF8H							

FCMD—Flash Command
 73H = First unlock command.
 8CH = Second unlock command.
 95H = Page erase command.
 63H = Mass erase command
 5EH = Flash Sector Protect register select.

* All other commands, or any command out of sequence, will lock the Flash Controller.



Flash Status Register

The Flash Status register indicates the current state of the Flash Controller. This register can be read at any time. The Read-only Flash Status Register shares its Register File address with the Write-only Flash Control Register.

Table 82. Flash Status Register (FSTAT)

BITS	7	6	5	4	3	2	1	0
FIELD	Reserved		FSTAT					
RESET	0	0	0	0	0	0	0	0
R/W	R	R	R	R	R	R	R	R
ADDR	FF8H							

Reserved

These bits are reserved and must be 0.

FSTAT—Flash Controller Status

00_0000 = Flash Controller locked.

00_0001 = First unlock command received.

00_0010 = Second unlock command received.

00_0011 = Flash Controller unlocked.

00_0100 = Flash Sector Protect register selected.

00_1xxx = Program operation in progress.

01_0xxx = Page erase operation in progress.

10_0xxx = Mass erase operation in progress.



Flash Page Select Register

The Flash Page Select (FPS) register selects the Flash memory page to be erased or programmed. Each Flash Page contains 512 bytes of Flash memory. During a Page Erase operation, all Flash memory locations with the 7 most significant bits of the address given by the PAGE field will be erased to FFH.

The Flash Page Select register shares its Register File address with the Flash Sector Protect Register. The Flash Page Select register cannot be accessed when the Flash Sector Protect register is enabled.

Table 83. Flash Page Select Register (FPS)

BITS	7	6	5	4	3	2	1	0
FIELD	INFO_EN	PAGE						
RESET	0	0	0	0	0	0	0	0
R/W	R/W	R/W	R/W	R/W	R/W	R/W	R/W	R/W
ADDR	FF9H							

INFO_EN—Information Area Enable

0 = Information Area is not selected.

1 = Information Area is selected. The Information area is mapped into the Program Memory address space at addresses FE00H through FFFFH.

PAGE—Page Select

This 7-bit field selects the Flash memory page for Programming and Page Erase operations. Program Memory Address[15:9] = PAGE[6:0].



Flash Sector Protect Register

The Flash Sector Protect register protects Flash memory sectors from being programmed or erased from user code. The Flash Sector Protect register shares its Register File address with the Flash Page Select register. The Flash Sector protect register can be accessed only after writing the Flash Control register with 5EH.

User code can only write bits in this register to 1 (bits cannot be cleared to 0 by user code).

Table 84. Flash Sector Protect Register (FPROT)

BITS	7	6	5	4	3	2	1	0
FIELD	SECT7	SECT6	SECT5	SECT4	SECT3	SECT2	SECT1	SECT0
RESET	0	0	0	0	0	0	0	0
R/W	R/W1	R/W1	R/W1	R/W1	R/W1	R/W1	R/W1	R/W1
ADDR	FF9H							
R/W1 = Register is accessible for Read operations. Register can be written to 1 only (via user code).								

SECT n —Sector Protect

0 = Sector n can be programmed or erased from user code.

1 = Sector n is protected and cannot be programmed or erased from user code.

* User code can only write bits from 0 to 1.



Flash Frequency High and Low Byte Registers

The Flash Frequency High and Low Byte registers combine to form a 16-bit value, FFREQ, to control timing for Flash program and erase operations. The 16-bit Flash Frequency registers should be written with the system clock frequency in kHz for Program and Erase operations. The Flash Frequency value is calculated using the following equation:

$$\text{FFREQ}[15:0] = \{ \text{FFREQH}[7:0], \text{FFREQL}[7:0] \} = \frac{\text{System Clock Frequency}}{1000}$$



Caution: Flash programming and erasure is not supported for system clock frequencies below 20kHz, above 20MHz, or outside of the valid operating frequency range for the device. The Flash Frequency High and Low Byte registers must be loaded with the correct value to insure proper program and erase times.

Table 85. Flash Frequency High Byte Register (FFREQH)

BITS	7	6	5	4	3	2	1	0
FIELD	FFREQH							
RESET	0	0	0	0	0	0	0	0
R/W	R/W	R/W	R/W	R/W	R/W	R/W	R/W	R/W
ADDR	FFAH							

Table 86. Flash Frequency Low Byte Register (FFREQL)

BITS	7	6	5	4	3	2	1	0
FIELD	FFREQL							
RESET	0	0	0	0	0	0	0	0
R/W	R/W	R/W	R/W	R/W	R/W	R/W	R/W	R/W
ADDR	FFBH							

FFREQH and FFREQL—Flash Frequency High and Low Bytes
These 2 bytes, {FFREQH[7:0], FFREQL[7:0]}, contain the 16-bit Flash Frequency value.



Option Bits

Overview

Option Bits allow user configuration of certain aspects of Z8F082x family operation. The feature configuration data is stored in Program Memory and read during Reset. The features available for control through the Option Bits are:

- Watch-Dog Timer time-out response selection—interrupt or Reset.
- Watch-Dog Timer enabled at Reset.
- The ability to prevent unwanted read access to user code in Program Memory.
- The ability to prevent accidental programming and erasure of all or a portion of the user code in Program Memory.
- Voltage Brown-Out configuration—always enabled or disabled during STOP mode to reduce STOP mode power consumption.
- Oscillator mode selection—for high, medium, and low power crystal oscillators, or external RC oscillator.

Operation

Option Bit Configuration By Reset

Each time the Option Bits are programmed or erased, the device must be Reset for the change to take place. During any reset operation (System Reset, Reset, or STOP Mode Recovery), the Option Bits are automatically read from the Program Memory and written to Option Configuration registers. The Option Configuration registers control operation of the devices within the Z8F082x family. Option Bit control is established before the device exits Reset and the eZ8 CPU begins code execution. The Option Configuration registers are not part of the Register File and are not accessible for read or write access.

Option Bit Address Space

The first two bytes of Program Memory at addresses 0000H and 0001H are reserved for the user programmable Option Bits. The byte at Program Memory address 0000H configures user options. The byte at Program Memory address 0001H is reserved for future use and must be left in its unprogrammed state.



Program Memory Address 0000H

Table 87. Option Bits At Program Memory Address 0000H

BITS	7	6	5	4	3	2	1	0
FIELD	WDT_RES	WDT_AO	OSC_SEL[1:0]		VBO_AO	RP	FHSWP	FWP
RESET	U							
R/W	R/W							
ADDR	Program Memory 0000H							

Note: U = Unchanged by Reset. R/W = Read/Write.

WDT_RES—Watch-Dog Timer Reset

0 = Watch-Dog Timer time-out generates an interrupt request. Interrupts must be globally enabled for the eZ8 CPU to acknowledge the interrupt request.

1 = Watch-Dog Timer time-out causes a Reset. This setting is the default for unprogrammed (erased) Flash.

WDT_AO—Watch-Dog Timer Always On

0 = Watch-Dog Timer is automatically enabled upon application of system power. Watch-Dog Timer can not be disabled.

1 = Watch-Dog Timer is enabled upon execution of the WDT instruction. Once enabled, the Watch-Dog Timer can only be disabled by a Reset or STOP Mode Recovery. This setting is the default for unprogrammed (erased) Flash.

OSC_SEL[1:0]—Oscillator Mode Selection

00 = On-chip oscillator configured for use with external RC networks (<4MHz).

01 = Minimum power for use with very low frequency crystals (32KHz to 1.0MHz).

10 = Medium power for use with medium frequency crystals or ceramic resonators (0.5MHz to 10.0MHz).

11 = Maximum power for use with high frequency crystals (8.0MHz to 20.0MHz). This setting is the default for unprogrammed (erased) Flash.

VBO_AO—Voltage Brown-Out Protection Always On

0 = Voltage Brown-Out Protection is disabled in STOP mode to reduce total power consumption.

1 = Voltage Brown-Out Protection is always enabled including during STOP mode. This setting is the default for unprogrammed (erased) Flash.

RP—Read Protect

0 = User program code is inaccessible. Limited control features are available through the On-Chip Debugger.

1 = User program code is accessible. All On-Chip Debugger commands are enabled. This setting is the default for unprogrammed (erased) Flash.



FHSWP—Flash High Sector Write Protect

FWP—Flash Write Protect

These two Option Bits combine to provide 3 levels of Program Memory protection:

FHSWP	FWP	Description
0	0	Programming and erasure disabled for all of Program Memory. Programming, Page Erase, and Mass Erase via User Code is disabled. Mass Erase is available through the On-Chip Debugger.
1	0	Programming and Page Erase are enabled for the High Sector of the Program Memory only. The High Sector on the Z8F082x family products contains 512 to 1024 Bytes of Flash with addresses at the top of the available Flash memory. Programming and Page Erase are disabled for the other portions of the Program Memory. Mass erase through user code is disabled. Mass Erase is available through the On-Chip Debugger.
0 or 1	1	Programming, Page Erase, and Mass Erase are enabled for all of Program Memory.

Program Memory Address 0001H

Table 88. Options Bits at Program Memory Address 0001H

BITS	7	6	5	4	3	2	1	0
FIELD	Reserved							
RESET	U							
R/W	R/W							
ADDR	Program Memory 0001H							

Note: U = Unchanged by Reset. R/W = Read/Write.

Reserved

These Option Bits are reserved for future use and must always be 1. This setting is the default for unprogrammed (erased) Flash.

On-Chip Debugger

Overview

The Z8F082x family products have an integrated On-Chip Debugger (OCD) that provides advanced debugging features including:

- Reading and writing of the Register File
- Reading and writing of Program and Data Memory
- Setting of Breakpoints
- Execution of eZ8 CPU instructions.

Architecture

The On-Chip Debugger consists of four primary functional blocks: transmitter, receiver, auto-baud generator, and debug controller. Figure 31 illustrates the architecture of the On-Chip Debugger

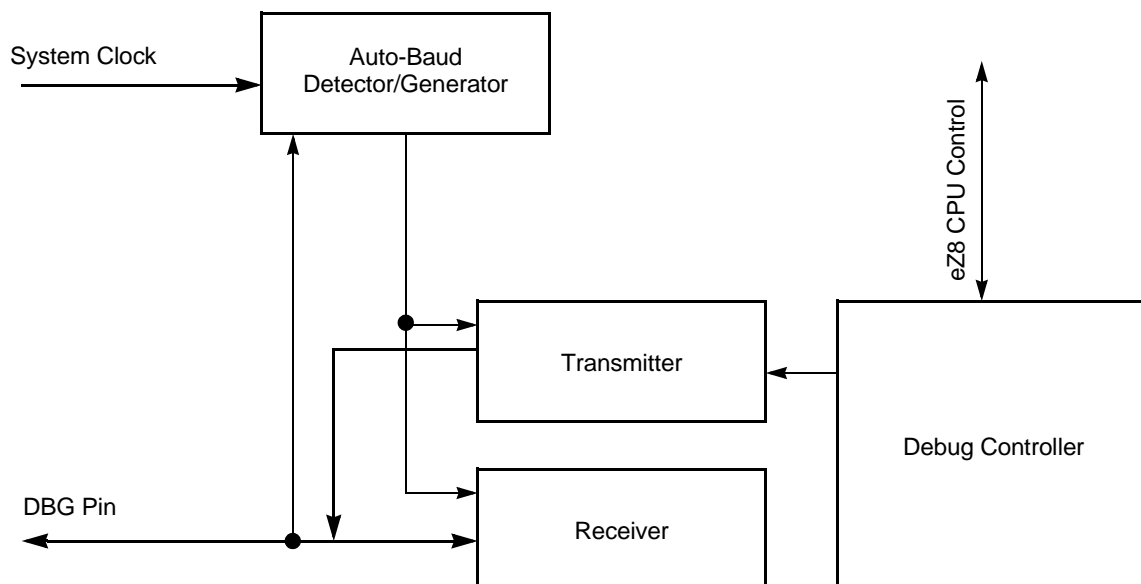

Figure 31. On-Chip Debugger Block Diagram

Operation

OCD Interface

The On-Chip Debugger uses the DBG pin for communication with an external host. This one-pin interface is a bi-directional open-drain interface that transmits and receives data. Data transmission is half-duplex, in that transmit and receive cannot occur simultaneously. The serial data on the DBG pin is sent using the standard asynchronous data format defined in RS-232. This pin can interface the Z8F082x family products to the serial port of a host PC using minimal external hardware. Two different methods for connecting the DBG pin to an RS-232 interface are depicted in Figures 32 and 33.



Caution:

For operation of the On-Chip Debugger, all power pins (VDD and AVDD) must be supplied with power, and all ground pins (VSS and AVSS) must be properly grounded.

The DBG pin is open-drain and must always be connected to VDD through an external pull-up resistor to insure proper operation.

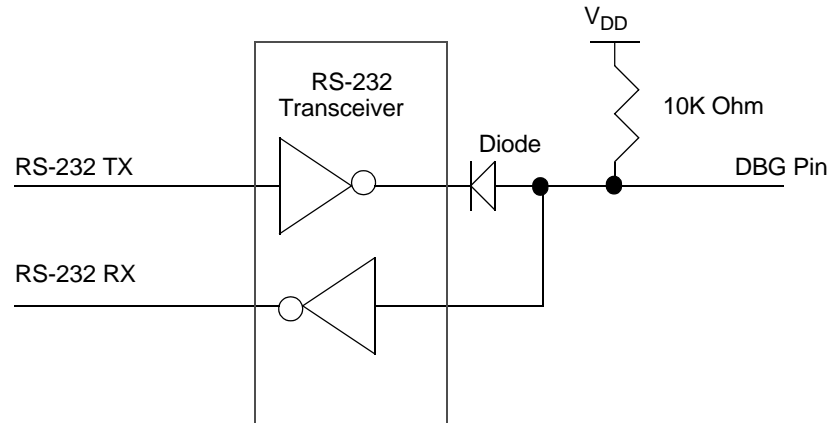

Figure 32. Interfacing the On-Chip Debugger's DBG Pin with an RS-232 Interface (1)

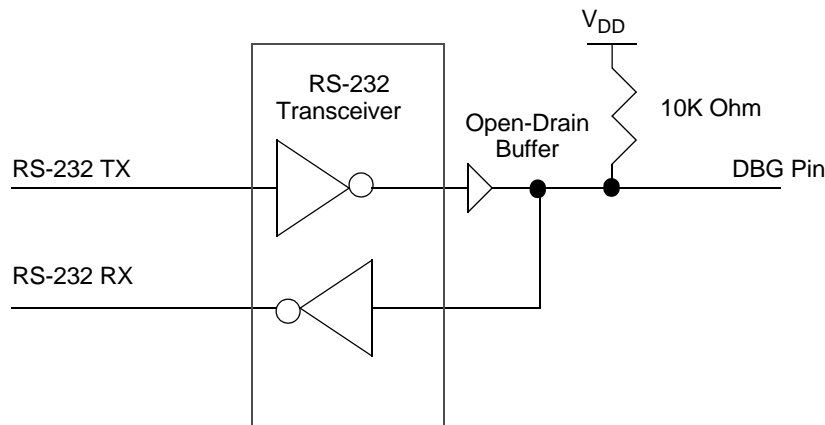

Figure 33. Interfacing the On-Chip Debugger's DBG Pin with an RS-232 Interface (2)

Debug Mode

The operating characteristics of the Z8F082x family devices in DEBUG mode are:

- The eZ8 CPU fetch unit stops, idling the eZ8 CPU, unless directed by the OCD to execute specific instructions.
- The system clock operates unless in STOP mode.
- All enabled on-chip peripherals operate unless in STOP mode.
- Automatically exits HALT mode.
- Constantly refreshes the Watch-Dog Timer, if enabled.

Entering Debug Mode

The device enters DEBUG mode following any of the following operations:

- Writing the DBGMODE bit in the OCD Control Register to 1 using the OCD interface.
- eZ8 CPU execution of a BRK (Breakpoint) instruction.
- Match of PC to OCDCNTR register (when enabled)
- OCDCNTR register decrements to 0000H (when enabled)
- If the DBG pin is Low when the device exits Reset, the On-Chip Debugger automatically puts the device into DEBUG mode.

Exiting Debug Mode

The device exits DEBUG mode following any of the following operations:

- Clearing the DBGMODE bit in the OCD Control Register to 0.



- Power-on reset
- Voltage Brown-out reset
- Asserting the $\overline{\text{RESET}}$ pin Low to initiate a Reset.
- Driving the DBG pin Low while the device is in STOP mode initiates a System Reset.

OCD Data Format

The OCD interface uses the asynchronous data format defined for RS-232. Each character is transmitted as 1 *start* bit, 8 data bits (least-significant bit first), and 1 *stop* bit (Figure 34)



Figure 34. OCD Data Format

OCD Auto-Baud Detector/Generator

To run over a range of baud rates (bits per second) with various system clock frequencies, the On-Chip Debugger has an Auto-Baud Detector/Generator. After a reset, the OCD is idle until it receives data. The OCD requires that the first character sent from the host is the character 80H. The character 80H has eight continuous bits Low (one Start bit plus 7 data bits). The Auto-Baud Detector measures this period and sets the OCD Baud Rate Generator accordingly.

The Auto-Baud Detector/Generator is clocked by the system clock. The minimum baud rate is the system clock frequency divided by 512. For optimal operation, the maximum recommended baud rate is the system clock frequency divided by 8. The theoretical maximum baud rate is the system clock frequency divided by 4. This theoretical maximum is possible for low noise designs with clean signals. Table 89 lists minimum and recommended maximum baud rates for sample crystal frequencies.

Table 89. OCD Baud-Rate Limits

System Clock Frequency (MHz)	Recommended Maximum Baud Rate (kbits/s)	Minimum Baud Rate (kbits/s)
20.0	2500	39.1
1.0	125.0	1.96
0.032768 (32KHz)	4.096	0.064



If the OCD receives a Serial Break (nine or more continuous bits Low) the Auto-Baud Detector/Generator resets. The Auto-Baud Detector/Generator can then be reconfigured by sending 80H.

OCD Serial Errors

The On-Chip Debugger can detect any of the following error conditions on the DBG pin:

- Serial Break (a minimum of nine continuous bits Low)
- Framing Error (received Stop bit is Low)
- Transmit Collision (OCD and host simultaneous transmission detected by the OCD)

When the OCD detects one of these errors, it aborts any command currently in progress, transmits a Serial Break 4096 System Clock cycles long back to the host, and resets the Auto-Baud Detector/Generator. A Framing Error or Transmit Collision may be caused by the host sending a Serial Break to the OCD. Because of the open-drain nature of the interface, returning a Serial Break back to the host only extends the length of the Serial Break if the host releases the Serial Break early.

The host should transmit a Serial Break on the DBG pin when first connecting to the Z8F082x family device or when recovering from an error. A Serial Break from the host resets the Auto-Baud Generator/Detector but does not reset the OCD Control register. A Serial Break leaves the device in DEBUG mode if that is the current mode. The OCD is held in Reset until the end of the Serial Break when the DBG pin returns High. Because of the open-drain nature of the DBG pin, the host can send a Serial Break to the OCD even if the OCD is transmitting a character.

Breakpoints

Execution Breakpoints are generated using the BRK instruction (opcode 00H). When the eZ8 CPU decodes a BRK instruction, it signals the On-Chip Debugger. If Breakpoints are enabled, the OCD idles the eZ8 CPU and enters Debug Mode. If Breakpoints are not enabled, the OCD ignores the BRK signal and the BRK instruction operates as an NOP.

If breakpoints are enabled, the OCD can be configured to automatically enter DEBUG mode, or to loop on the break instruction. If the OCD is configured to loop on the BRK instruction, then the CPU is still enabled to service DMA and interrupt requests.

The loop on BRK instruction can be used to service interrupts in the background. For interrupts to be serviced in the background, there cannot be any breakpoints in the interrupt service routine. Otherwise, the CPU stops on the breakpoint in the interrupt routine. For interrupts to be serviced in the background, interrupts must also be enabled. Debugging software should not automatically enable interrupts when using this feature, since interrupts are typically disabled during critical sections of code where interrupts should not occur (such as adjusting the stack pointer or modifying shared data).

Software can poll the IDLE bit of the OCDSTAT register to determine if the OCD is looping on a BRK instruction. When software wants to stop the CPU on the BRK instruction it is looping on, software should not set the DBGMODE bit of the OCDCTL register. The CPU may have vectored to and be in the middle of an interrupt service routine when this bit gets set. Instead, software should clear the BRKLP bit. This allows the CPU to finish the interrupt service routine it may be in and return the BRK instruction. When the CPU returns to the BRK instruction it was previously looping on, it automatically sets the DBGMODE bit and enter DEBUG mode.

Software should also note that the majority of the OCD commands are still disabled when the eZ8 CPU is looping on a BRK instruction. The eZ8 CPU must be stopped and the part must be in DEBUG mode before these commands can be issued.

Breakpoints in Flash Memory

The BRK instruction is opcode 00H, which corresponds to the fully programmed state of a byte in Flash memory. To implement a Breakpoint, write 00H to the desired address, overwriting the current instruction. To remove a Breakpoint, the corresponding page of Flash memory must be erased and reprogrammed with the original data.

OCDCNTR Register

The On-Chip Debugger contains a multipurpose 16-bit Counter Register. It can be used for the following:

- Count system clock cycles between Breakpoints.
- Generate a BRK when it counts down to zero.
- Generate a BRK when its value matches the Program Counter.

When configured as a counter, the OCDCNTR register starts counting when the On-Chip Debugger leaves DEBUG mode and stops counting when it enters DEBUG mode again or when it reaches the maximum count of FFFFH. The OCDCNTR register automatically resets itself to 0000H when the OCD exits DEBUG mode if it is configured to count clock cycles between breakpoints.



Caution: The OCDCNTR register is used by many of the OCD commands. It counts the number of bytes for the register and memory read/write commands. It holds the residual value when generating the CRC. Therefore, if the OCDCNTR is being used to generate a BRK, its value should be written as a last step before leaving DEBUG mode.

Since this register is overwritten by various OCD commands, it should only be used to generate temporary breakpoints, such as stepping over CALL instructions or running to a specific instruction and stopping.



On-Chip Debugger Commands

The host communicates to the On-Chip Debugger by sending OCD commands using the DBG interface. During normal operation, only a subset of the OCD commands are available. In DEBUG mode, all OCD commands become available unless the user code and control registers are protected by programming the Read Protect Option Bit (RP). The Read Protect Option Bit prevents the code in memory from being read out of the Z8F082x family products. When this option is enabled, several of the OCD commands are disabled. Table 90 contains a summary of the On-Chip Debugger commands. Each OCD command is described in further detail in the bulleted list following Table 90. Table 90 indicates those commands that operate when the device is not in DEBUG mode (normal operation) and those commands that are disabled by programming the Read Protect Option Bit.

Table 90. On-Chip Debugger Commands

Debug Command	Command Byte	Enabled when NOT in DEBUG mode?	Disabled by Read Protect Option Bit
Read OCD Revision	00H	Yes	-
Write OCD Counter Register	01H	-	-
Read OCD Status Register	02H	Yes	-
Read OCD Counter Register	03H	-	-
Write OCD Control Register	04H	Yes	Cannot clear DBGMODE bit
Read OCD Control Register	05H	Yes	-
Write Program Counter	06H	-	Disabled
Read Program Counter	07H	-	Disabled
Write Register	08H	-	Only writes of the Flash Memory Control registers are allowed. Additionally, only the Mass Erase command is allowed to be written to the Flash Control register.
Read Register	09H	-	Disabled
Write Program Memory	0AH	-	Disabled
Read Program Memory	0BH	-	Disabled
Write Data Memory	0CH	-	Yes
Read Data Memory	0DH	-	-
Read Program Memory CRC	0EH	-	-
Reserved	0FH	-	-
Step Instruction	10H	-	Disabled



Table 90. On-Chip Debugger Commands

Debug Command	Command Byte	Enabled when NOT in DEBUG mode?	Disabled by Read Protect Option Bit
Stuff Instruction	11H	-	Disabled
Execute Instruction	12H	-	Disabled
Reserved	13H - FFH	-	-

In the following bulleted list of OCD Commands, data and commands sent from the host to the On-Chip Debugger are identified by 'DBG ← Command/Data'. Data sent from the On-Chip Debugger back to the host is identified by 'DBG → Data'

- Read OCD Revision (00H)**—The Read OCD Revision command determines the version of the On-Chip Debugger. If OCD commands are added, removed, or changed, this revision number changes.
 - DBG ← 00H
 - DBG → OCDREV[15:8] (Major revision number)
 - DBG → OCDREV[7:0] (Minor revision number)
- Write OCD Counter Register (01H)**—The Write OCD Counter Register command writes the data that follows to the OCDCNTR register. If the device is not in DEBUG mode, the data is discarded.
 - DBG ← 01H
 - DBG ← OCDCNTR[15:8]
 - DBG ← OCDCNTR[7:0]
- Read OCD Status Register (02H)**—The Read OCD Status Register command reads the OCDSTAT register.
 - DBG ← 02H
 - DBG → OCDSTAT[7:0]
- Read OCD Counter Register (03H)**—The OCD Counter Register can be used to count system clock cycles in between Breakpoints, generate a BRK when it counts down to zero, or generate a BRK when its value matches the Program Counter. Since this register is really a down counter, the returned value is inverted when this register is read so the returned result appears to be an up counter. If the device is not in DEBUG mode, this command returns FFFFH.
 - DBG ← 03H
 - DBG → ~OCDCNTR[15:8]
 - DBG → ~OCDCNTR[7:0]
- Write OCD Control Register (04H)**—The Write OCD Control Register command writes the data that follows to the OCDCTL register. When the Read Protect Option Bit is enabled, the DBGMODE bit (OCDCTL[7]) can only be set to 1, it cannot be



cleared to 0 and the only method of putting the device back into normal operating mode is to reset the device.

```
DBG ← 04H
DBG ← OCDCTL[7:0]
```

- **Read OCD Control Register (05H)**—The Read OCD Control Register command reads the value of the OCDCTL register.

```
DBG ← 05H
DBG → OCDCTL[7:0]
```

- **Write Program Counter (06H)**—The Write Program Counter command writes the data that follows to the eZ8 CPU's Program Counter (PC). If the device is not in DEBUG mode or if the Read Protect Option Bit is enabled, the Program Counter (PC) values are discarded.

```
DBG ← 06H
DBG ← ProgramCounter[15:8]
DBG ← ProgramCounter[7:0]
```

- **Read Program Counter (07H)**—The Read Program Counter command reads the value in the eZ8 CPU's Program Counter (PC). If the device is not in DEBUG mode or if the Read Protect Option Bit is enabled, this command returns FFFFH.

```
DBG ← 07H
DBG → ProgramCounter[15:8]
DBG → ProgramCounter[7:0]
```

- **Write Register (08H)**—The Write Register command writes data to the Register File. Data can be written 1-256 bytes at a time (256 bytes can be written by setting size to zero). If the device is not in DEBUG mode, the address and data values are discarded. If the Read Protect Option Bit is enabled, then only writes to the Flash Control Registers are allowed and all other register write data values are discarded.

```
DBG ← 08H
DBG ← {4'h0, Register Address[11:8]}
DBG ← Register Address[7:0]
DBG ← Size[7:0]
DBG ← 1-256 data bytes
```

- **Read Register (09H)**—The Read Register command reads data from the Register File. Data can be read 1-256 bytes at a time (256 bytes can be read by setting size to zero). If the device is not in DEBUG mode or if the Read Protect Option Bit is enabled, this command returns FFH for all the data values.

```
DBG ← 09H
DBG ← {4'h0, Register Address[11:8]}
DBG ← Register Address[7:0]
DBG ← Size[7:0]
DBG → 1-256 data bytes
```



- **Write Program Memory (0AH)**—The Write Program Memory command writes data to Program Memory. This command is equivalent to the LDC and LDCI instructions. Data can be written 1-65536 bytes at a time (65536 bytes can be written by setting size to zero). The on-chip Flash Controller must be written to and unlocked for the programming operation to occur. If the Flash Controller is not unlocked, the data is discarded. If the device is not in DEBUG mode or if the Read Protect Option Bit is enabled, the data is discarded.

```
DBG ← 0AH
DBG ← Program Memory Address [15:8]
DBG ← Program Memory Address [7:0]
DBG ← Size [15:8]
DBG ← Size [7:0]
DBG ← 1-65536 data bytes
```

- **Read Program Memory (0BH)**—The Read Program Memory command reads data from Program Memory. This command is equivalent to the LDC and LDCI instructions. Data can be read 1-65536 bytes at a time (65536 bytes can be read by setting size to zero). If the device is not in DEBUG mode or if the Read Protect Option Bit is enabled, this command returns FFH for the data.

```
DBG ← 0BH
DBG ← Program Memory Address [15:8]
DBG ← Program Memory Address [7:0]
DBG ← Size [15:8]
DBG ← Size [7:0]
DBG → 1-65536 data bytes
```

- **Write Data Memory (0CH)**—The Write Data Memory command writes data to Data Memory. This command is equivalent to the LDE and LDEI instructions. Data can be written 1-65536 bytes at a time (65536 bytes can be written by setting size to 0). If the device is not in DEBUG mode or if the Read Protect Option Bit is enabled, the data is discarded.

```
DBG ← 0CH
DBG ← Data Memory Address [15:8]
DBG ← Data Memory Address [7:0]
DBG ← Size [15:8]
DBG ← Size [7:0]
DBG ← 1-65536 data bytes
```

- **Read Data Memory (0DH)**—The Read Data Memory command reads from Data Memory. This command is equivalent to the LDE and LDEI instructions. Data can be read 1-65536 bytes at a time (65536 bytes can be read by setting size to 0). If the device is not in DEBUG mode, this command returns FFH for the data.

```
DBG ← 0DH
DBG ← Data Memory Address [15:8]
DBG ← Data Memory Address [7:0]
DBG ← Size [15:8]
```



DBG ← Size[7:0]
DBG → 1-65536 data bytes

- **Read Program Memory CRC (0EH)**—The Read Program Memory CRC command computes and returns the CRC (cyclic redundancy check) of Program Memory using the 16-bit CRC-CCITT polynomial. If the device is not in DEBUG mode, this command returns FFFFH for the CRC value. Unlike most other OCD Read commands, there is a delay from issuing of the command until the OCD returns the data. The OCD reads the Program Memory, calculates the CRC value, and returns the result. The delay is a function of the Program Memory size and is approximately equal to the system clock period multiplied by the number of bytes in the Program Memory.

DBG ← 0EH
DBG → CRC[15:8]
DBG → CRC[7:0]

- **Step Instruction (10H)**—The Step Instruction command steps one assembly instruction at the current Program Counter (PC) location. If the device is not in DEBUG mode or the Read Protect Option Bit is enabled, the OCD ignores this command.

DBG ← 10H

- **Stuff Instruction (11H)**—The Stuff Instruction command steps one assembly instruction and allows specification of the first byte of the instruction. The remaining 0-4 bytes of the instruction are read from Program Memory. This command is useful for stepping over instructions where the first byte of the instruction has been overwritten by a Breakpoint. If the device is not in DEBUG mode or the Read Protect Option Bit is enabled, the OCD ignores this command.

DBG ← 11H
DBG ← opcode[7:0]

- **Execute Instruction (12H)**—The Execute Instruction command allows sending an entire instruction to be executed to the eZ8 CPU. This command can also step over Breakpoints. The number of bytes to send for the instruction depends on the opcode. If the device is not in DEBUG mode or the Read Protect Option Bit is enabled, the OCD ignores this command

DBG ← 12H
DBG ← 1-5 byte opcode

On-Chip Debugger Control Register Definitions

OCD Control Register

The OCD Control register controls the state of the On-Chip Debugger. This register enters or exits DEBUG mode and enables the BRK instruction. It can also reset the Z8F082x family device.



A “reset and stop” function can be achieved by writing 81H to this register. A “reset and go” function can be achieved by writing 41H to this register. If the device is in DEBUG mode, a “run” function can be implemented by writing 40H to this register.

Table 91. OCD Control Register (OCDCNTL)

BITS	7	6	5	4	3	2	1	0
FIELD	DBGMODE	BRKEN	DBGACK	BRKLOOP	BRKPC	BRKZRO	Reserved	RST
RESET	0	0	0	0	0	0	0	0
R/W	R/W	R/W	R/W	R	R	R	R	R/W

DBGMODE—Debug Mode

Setting this bit to 1 causes the device to enter DEBUG mode. When in DEBUG mode, the eZ8 CPU stops fetching new instructions. Clearing this bit causes the eZ8 CPU to start running again. This bit is automatically set when a BRK instruction is decoded and Breakpoints are enabled. If the Read Protect Option Bit is enabled, this bit can only be cleared by resetting the device, it cannot be written to 0.

0 = The Z8F082x family device is operating in NORMAL mode.

1 = The Z8F082x family device is in DEBUG mode.

BRKEN—Breakpoint Enable

This bit controls the behavior of the BRK instruction (opcode 00H). By default, Breakpoints are disabled and the BRK instruction behaves like a NOP. If this bit is set to 1 and a BRK instruction is decoded, the OCD takes action dependent upon the BRKLOOP bit.

0 = BRK instruction is disabled.

1 = BRK instruction is enabled.

DBGACK—Debug Acknowledge

This bit enables the debug acknowledge feature. If this bit is set to 1, then the OCD sends an Debug Acknowledge character (FFH) to the host when a Breakpoint occurs.

0 = Debug Acknowledge is disabled.

1 = Debug Acknowledge is enabled.

BRKLOOP—Breakpoint Loop

This bit determines what action the OCD takes when a BRK instruction is decoded if breakpoints are enabled (BRKEN is 1). If this bit is 0, then the DBGMODE bit is automatically set to 1 and the OCD entered DEBUG mode. If BRKLOOP is set to 1, then the eZ8 CPU loops on the BRK instruction.

0 = BRK instruction sets DBGMODE to 1.

1 = eZ8 CPU loops on BRK instruction.

BRKPC—Break when PC == OCDCNTR

If this bit is set to 1, then the OCDCNTR register is used as a hardware breakpoint. When the program counter matches the value in the OCDCNTR register, DBGMODE is auto-



matically set to 1. If this bit is set, the OCDCNTR register does not count when the CPU is running.

0 = OCDCNTR is setup as counter

1 = OCDCNTR generates hardware break when PC == OCDCNTR

BRKZRO—Break when OCDCNTR == 0000H

If this bit is set, then the OCD automatically sets the DBGMODE bit when the OCDCNTR register counts down to 0000H. If this bit is set, the OCDCNTR register is not reset when the part leaves DEBUG Mode.

0 = OCD does not generate BRK when OCDCNTR decrements to 0000H

1 = OCD sets DBGMODE to 1 when OCDCNTR decrements to 0000H

Reserved

These bits are reserved and must be 0.

RST—Reset

Setting this bit to 1 resets the Z8F082x family device. The device goes through a normal Power-On Reset sequence with the exception that the On-Chip Debugger is not reset. This bit is automatically cleared to 0 when the reset finishes.

0 = No effect.

1 = Reset the Z8F082x family device.

OCD Status Register

The OCD Status register reports status information about the current state of the debugger and the system.

Table 92. OCD Status Register (OCDSTAT)

BITS	7	6	5	4	3	2	1	0
FIELD	IDLE	HALT	RPEN	Reserved				
RESET	0	0	0	0	0	0	0	0
R/W	R	R	R	R	R	R	R	R

IDLE—CPU idling

This bit is set if the part is in DEBUG mode (DBGMODE is 1), or if a BRK instruction occurred since the last time OCDCTL was written. This can be used to determine if the CPU is running or if it is idling.

0 = The eZ8 CPU is running.

1 = The eZ8 CPU is either stopped or looping on a BRK instruction.

HALT—HALT Mode

0 = The device is not in HALT mode.

1 = The device is in HALT mode.



RPEN—Read Protect Option Bit Enabled

0 = The Read Protect Option Bit is disabled (1).

1 = The Read Protect Option Bit is enabled (0), disabling many OCD commands.

Reserved. Must be 0.



On-Chip Oscillator

Overview

The products in the Z8F082x family feature an on-chip oscillator for use with external crystals with frequencies from 32KHz to 20MHz. In addition, the oscillator can support external RC networks with oscillation frequencies up to 4MHz or ceramic resonators with frequencies up to 20MHz. This oscillator generates the primary system clock for the internal eZ8 CPU and the majority of the on-chip peripherals. Alternatively, the X_{IN} input pin can also accept a CMOS-level clock input signal (32kHz–20MHz). If an external clock generator is used, the X_{OUT} pin must be left unconnected.

When configured for use with crystal oscillators or external clock drivers, the frequency of the signal on the X_{IN} input pin determines the frequency of the system clock (that is, no internal clock divider). In RC operation, the system clock is driven by a clock divider (divide by 2) to ensure 50% duty cycle.

Operating Modes

The Z8F082x family products support four different oscillator modes:

- On-chip oscillator configured for use with external RC networks (<4MHz).
- Minimum power for use with very low frequency crystals (32KHz to 1.0MHz).
- Medium power for use with medium frequency crystals or ceramic resonators (0.5MHz to 10.0MHz).
- Maximum power for use with high frequency crystals or ceramic resonators (8.0MHz to 20.0MHz).

The oscillator mode is selected using user-programmable Option Bits. Please refer to the **Option Bits** chapter for information.

Crystal Oscillator Operation

Figure 35 illustrates a recommended configuration for connection with an external fundamental-mode, parallel-resonant crystal operating at 20MHz. Recommended 20MHz crystal specifications are provided in Table 93. Resistor R₁ is optional and limits total power dissipation by the crystal. Printed circuit board layout should add no more than 4pF of

stray capacitance to either the X_{IN} or X_{OUT} pins. If oscillation does not occur, reduce the values of capacitors C_1 and C_2 to decrease loading.

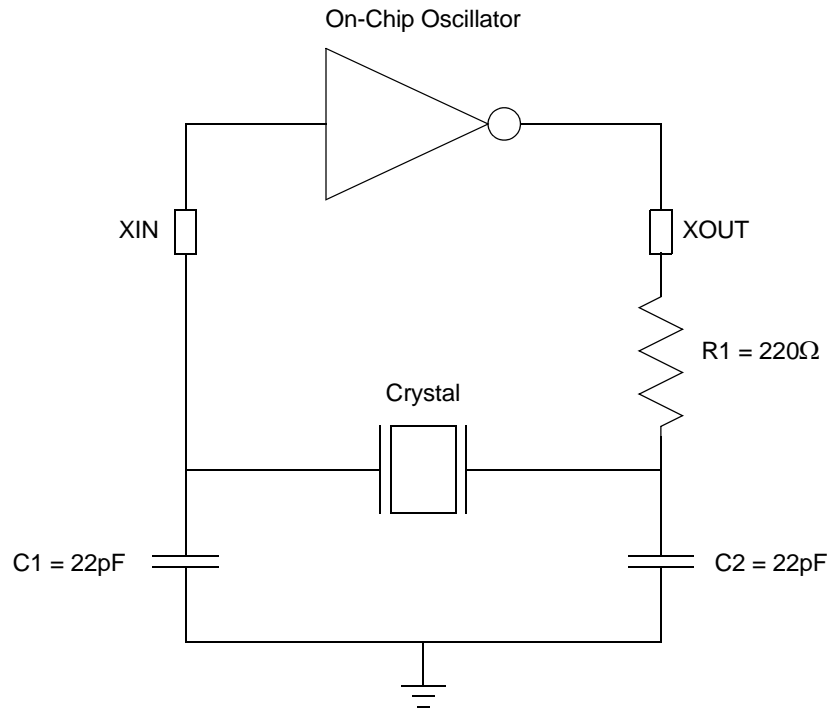

Figure 35. Recommended 20MHz Crystal Oscillator Configuration

Table 93. Recommended Crystal Oscillator Specifications (20MHz Operation)

Parameter	Value	Units	Comments
Frequency	20	MHz	
Resonance Mode	Parallel		
Mode	Fundamental		
Series Resistance (R_S)	25	W	Maximum
Load Capacitance (C_L)	20	pF	Maximum
Shunt Capacitance (C_0)	7	pF	Maximum
Drive Level	1	mW	Maximum

Oscillator Operation with an External RC Network

Figure 36 illustrates a recommended configuration for connection with an external resistor-capacitor (RC) network.

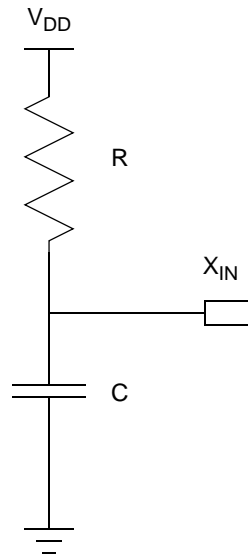

Figure 36. Connecting the On-Chip Oscillator to an External RC Network

An external resistance value of 15k Ω is recommended for oscillator operation with an external RC network. The minimum resistance value to ensure operation is 10k Ω . The typical oscillator frequency can be estimated from the values of the resistor (R in k Ω) and capacitor (C in pF) elements using the following equation:

$$\text{Oscillator Frequency (kHz)} = \frac{1 \times 10^6}{(1.5 \times R \times C)}$$

Figure 37 illustrates the typical (3.3V and 25⁰C) oscillator frequency as a function of the capacitor (C in pF) employed in the RC network assuming a 15k Ω external resistor. For very small values of C , the parasitic capacitance of the oscillator X_{IN} pin and the printed circuit board should be included in the estimation of the oscillator frequency.

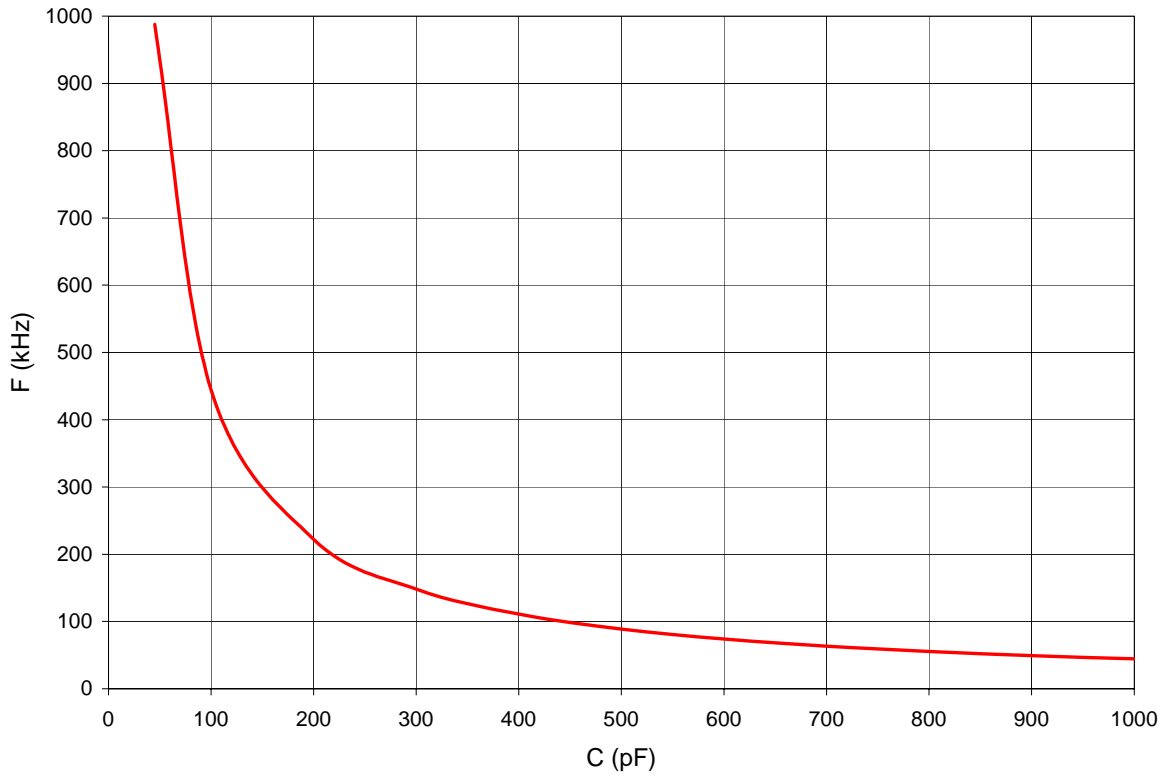

Figure 37. Typical RC Oscillator Frequency as a Function of the External Capacitance with a 15kΩ Resistor



Electrical Characteristics

All data in this chapter is pre-qualification and pre-characterization and is subject to change.

Absolute Maximum Ratings



Caution: Stresses greater than those listed in Table 94 may cause permanent damage to the device.

These ratings are stress ratings only. Operation of the device at any condition outside those indicated in the operational sections of these specifications is not implied. Exposure to absolute maximum rating conditions for extended periods may affect device reliability. For improved reliability, unused inputs must be tied to one of the supply voltages (V_{DD} or V_{SS}).

Table 94. Absolute Maximum Ratings

Parameter	Minimum	Maximum	Units	Notes
Ambient temperature under bias	-40°	+105°	C	1
Storage temperature	-65	+150	C	
Voltage on any pin with respect to V_{SS}	-0.3	+5.5	V	2
Voltage on AV_{SS} pin with respect to V_{SS}	-0.3	+0.3	V	2
Voltage on V_{DD} pin with respect to V_{SS}	-0.3	+3.6	V	
Voltage on AV_{DD} pin with respect to V_{DD}	-0.3	+0.3	V	
Maximum current on input and/or inactive output pin	-5	+5	μ A	
Maximum output current from active output pin	-25	+25	mA	
20-pin SSOP Package Maximum Ratings at 0°C to 70°C				
Total power dissipation		430	mW	
Maximum current into V_{DD} or out of V_{SS}		120	mA	

Notes:

1. This voltage applies to all pins except the following: V_{DD} , AV_{DD} , V_{REF} , pins supporting analog input (Port B), and where noted otherwise.



Table 94. Absolute Maximum Ratings (Continued)

Parameter	Minimum	Maximum	Units	Notes
20-pin SSOP Package Maximum Ratings at 70°C to 105°C				
Total power dissipation		250	mW	
Maximum current into V _{DD} or out of V _{SS}		69	mA	
20-pin PDIP Package Maximum Ratings at 0°C to 70°C				
Total power dissipation		775	mW	
Maximum current into V _{DD} or out of V _{SS}		215	mA	
20-pin PDIP Package Maximum Ratings at 70°C to 105°C				
Total power dissipation		285	mW	
Maximum current into V _{DD} or out of V _{SS}		79	mA	
28-pin SOIC Package Maximum Ratings at 0°C to 70°C				
Total power dissipation		450	mW	
Maximum current into V _{DD} or out of V _{SS}		125	mA	
28-pin SOIC Package Maximum Ratings at 70°C to 105°C				
Total power dissipation		260	mW	
Maximum current into V _{DD} or out of V _{SS}		73	mA	
28-pin PDIP Package Maximum Ratings at 0°C to 70°C				
Total power dissipation		1100	mW	
Maximum current into V _{DD} or out of V _{SS}		305	mA	
28-pin PDIP Package Maximum Ratings at 70°C to 105°C				
Total power dissipation		400	mW	
Maximum current into V _{DD} or out of V _{SS}		110	mA	

Notes:

1. This voltage applies to all pins except the following: VDD, AVDD, VREF, pins supporting analog input (Port B), and where noted otherwise.



DC Characteristics

Table 95 lists the DC characteristics of the Z8F082x family products. All voltages are referenced to V_{SS} , the primary system ground.

Table 95. DC Characteristics

Symbol	Parameter	$T_A = -40^{\circ}\text{C to } 105^{\circ}\text{C}$			Units	Conditions
		Minimum	Typical	Maximum		
V_{DD}	Supply Voltage	2.7	–	3.6	V	
V_{IL1}	Low Level Input Voltage	-0.3	–	$0.3 \cdot V_{DD}$	V	For all input pins except $\overline{\text{RESET}}$, DBG, and XIN.
V_{IL2}	Low Level Input Voltage	-0.3	–	$0.2 \cdot V_{DD}$	V	For $\overline{\text{RESET}}$, DBG, and XIN.
V_{IH1}	High Level Input Voltage	$0.7 \cdot V_{DD}$	–	5.5	V	Ports A and C pins when their programmable pull-ups are disabled.
V_{IH2}	High Level Input Voltage	$0.7 \cdot V_{DD}$	–	$V_{DD} + 0.3$	V	Port B pins.
V_{IH3}	High Level Input Voltage	$0.8 \cdot V_{DD}$	–	$V_{DD} + 0.3$	V	$\overline{\text{RESET}}$, DBG, and XIN pins.
V_{OL1}	Low Level Output Voltage	–	–	0.4	V	$I_{OL} = 2\text{mA}$; $V_{DD} = 3.0\text{V}$ High Output Drive disabled.
V_{OH1}	High Level Output Voltage	2.4	–	–	V	$I_{OH} = -2\text{mA}$; $V_{DD} = 3.0\text{V}$ High Output Drive disabled.
V_{OL2}	Low Level Output Voltage High Drive	–	–	0.6	V	$I_{OL} = 20\text{mA}$; $V_{DD} = 3.3\text{V}$ High Output Drive enabled $T_A = -40^{\circ}\text{C to } +70^{\circ}\text{C}$
V_{OH2}	High Level Output Voltage High Drive	2.4	–	–	V	$I_{OH} = -20\text{mA}$; $V_{DD} = 3.3\text{V}$ High Output Drive enabled; $T_A = -40^{\circ}\text{C to } +70^{\circ}\text{C}$
V_{OL3}	Low Level Output Voltage High Drive	–	–	0.6	V	$I_{OL} = 15\text{mA}$; $V_{DD} = 3.3\text{V}$ High Output Drive enabled; $T_A = +70^{\circ}\text{C to } +105^{\circ}\text{C}$
V_{OH3}	High Level Output Voltage High Drive	2.4	–	–	V	$I_{OH} = 15\text{mA}$; $V_{DD} = 3.3\text{V}$ High Output Drive enabled; $T_A = +70^{\circ}\text{C to } +105^{\circ}\text{C}$
I_{IL}	Input Leakage Current	-5	–	+5	μA	$V_{DD} = 3.6\text{V}$; $V_{IN} = V_{DD}$ or V_{SS}^1
I_{TL}	Tri-State Leakage Current	-5	–	+5	μA	$V_{DD} = 3.6\text{V}$
C_{PAD}	GPIO Port Pad Capacitance	–	8.0^2	–	pF	
C_{XIN}	XIN Pad Capacitance	–	8.0^2	–	pF	



Table 95. DC Characteristics

Symbol	Parameter	T _A = -40 ⁰ C to 105 ⁰ C			Units	Conditions
		Minimum	Typical	Maximum		
C _{XOUT}	XOUT Pad Capacitance	–	9.5 ²	–	pF	
I _{PU1}	Weak Pull-up Current	9	20	50	μA	V _{DD} = 2.7 - 3.6V. T _A = 0 ⁰ C to +70 ⁰ C
I _{PU2}	Weak Pull-up Current	7	20	75	μA	V _{DD} = 2.7 - 3.6V. T _A = -40 ⁰ C to +105 ⁰ C
I _{CCS1}	Supply Current in Stop Mode with VBO Enabled		600		μA	V _{DD} = 2.7V; 25 ⁰ C
I _{CCS2}	Supply Current in Stop Mode with VBO Disabled		2		μA	V _{DD} = 2.7V; 25 ⁰ C
I _{CCS3}	Supply Current in Stop Mode with VBO and WDT disabled			1	μA	V _{DD} = 2.7V; 25 ⁰ C

¹ This condition excludes all pins that have on-chip pull-ups, when driven Low.

² These values are provided for design guidance only and are not tested in production.

Figure 38 illustrates the typical current consumption while operating at 25°C, 3.3V, versus the system clock frequency.

TBD

Figure 38. ICC Versus System Clock Frequency

Figure 39 illustrates the typical current consumption in HALT mode while operating at 25°C, 3.3V, versus the system clock frequency.



TBD

Figure 39. ICC Versus System Clock Frequency

AC Characteristics

The section provides information on the AC characteristics and timing. All AC timing information assumes a standard load of 50pF on all outputs.

Table 96. AC Characteristics

Symbol	Parameter	$V_{DD} = 2.7 - 3.6V$ $T_A = 0^{\circ}C \text{ to } 70^{\circ}C$		Units	Conditions
		Minimum	Maximum		
F _{sysclk}	System Clock Frequency	–	20.0	MHz	Read-only from Flash memory.
		0.032768	20.0	MHz	Program or erasure of the Flash memory.
F _{XTAL}	Crystal Oscillator Frequency	0.032768	20.0	MHz	System clock frequencies below the crystal oscillator minimum require an external clock driver.
T _{XIN}	System Clock Period	50	–	ns	T _{CLK} = 1/F _{sysclk}
T _{XINH}	System Clock High Time	20	30	ns	T _{CLK} = 50ns



Table 96. AC Characteristics (Continued)

Symbol	Parameter	$V_{DD} = 2.7 - 3.6V$ $T_A = 0^{\circ}C \text{ to } 70^{\circ}C$		Units	Conditions
		Minimum	Maximum		
T_{XINL}	System Clock Low Time	20	30	ns	$T_{CLK} = 50ns$
T_{XINR}	System Clock Rise Time	–	3	ns	$T_{CLK} = 50ns$
T_{XINF}	System Clock Fall Time	–	3	ns	$T_{CLK} = 50ns$



On-Chip Peripheral AC and DC Electrical Characteristics

Table 97. Power-On Reset and Voltage Brown-Out Electrical Characteristics and Timing

Symbol	Parameter	$T_A = -40^{\circ}\text{C to } 105^{\circ}\text{C}$			Units	Conditions
		Minimum	Typical ¹	Maximum		
V_{POR}	Power-On Reset Voltage Threshold	2.15	2.40	2.60	V	$V_{\text{DD}} = V_{\text{POR}}$
V_{VBO}	Voltage Brown-Out Reset Voltage Threshold	2.05	2.30	2.55	V	$V_{\text{DD}} = V_{\text{VBO}}$
	V_{POR} to V_{VBO} hysteresis	50	100	–	mV	
	Starting V_{DD} voltage to ensure valid Power-On Reset.	–	V_{SS}	–	V	
T_{ANA}	Power-On Reset Analog Delay	–	50	–	μs	$V_{\text{DD}} > V_{\text{POR}}$; T_{POR} Digital Reset delay follows T_{ANA}
T_{POR}	Power-On Reset Digital Delay	–	10.2	–	ms	512 WDT Oscillator cycles (50KHz) + 70 System Clock cycles (20MHz)
T_{VBO}	Voltage Brown-Out Pulse Rejection Period	–	10	–	μs	$V_{\text{DD}} < V_{\text{VBO}}$ to generate a Reset.
T_{RAMP}	Time for V_{DD} to transition from V_{SS} to V_{POR} to ensure valid Reset	0.10	–	100	ms	

¹ Data in the typical column is from characterization at 3.3V and 0°C. These values are provided for design guidance only and are not tested in production.

Table 98. Flash Memory Electrical Characteristics and Timing

Parameter	$V_{\text{DD}} = 2.7 - 3.6\text{V}$ $T_A = -40^{\circ}\text{C to } 105^{\circ}\text{C}$			Units	Notes
	Minimum	Typical	Maximum		
Flash Byte Read Time	50	–	–	μs	
Flash Byte Program Time	20	–	40	μs	
Flash Page Erase Time	10	–	–	ms	
Flash Mass Erase Time	200	–	–	ms	



Table 98. Flash Memory Electrical Characteristics and Timing (Continued)

Parameter	V _{DD} = 2.7 - 3.6V T _A = -40 ⁰ C to 105 ⁰ C			Units	Notes
	Minimum	Typical	Maximum		
Writes to Single Address Before Next Erase	–	–	2		
Flash Row Program Time	–	–	8	ms	Cumulative program time for single row cannot exceed limit before next erase. This parameter is only an issue when bypassing the Flash Controller.
Data Retention	100	–	–	years	25 ⁰ C
Endurance	10,000	–	–	cycles	Program / erase cycles

Table 99. Watch-Dog Timer Electrical Characteristics and Timing

Symbol	Parameter	V _{DD} = 2.7 - 3.6V T _A = -40 ⁰ C to 105 ⁰ C			Units	Conditions
		Minimum	Typical	Maximum		
F _{WDT}	WDT Oscillator Frequency	5	10	20	kHz	

Table 100. Analog-to-Digital Converter Electrical Characteristics and Timing

Symbol	Parameter	V _{DD} = 2.7 - 3.6V T _A = -40 ⁰ C to 105 ⁰ C			Units	Conditions
		Minimum	Typical	Maximum		
	Resolution	–	10	–	bits	External V _{REF} = 3.0V; R _S <= 3.0kΩ
	Differential Nonlinearity (DNL)	-1.0	–	1.0	LSB	External V _{REF} = 3.0V; R _S <= 3.0kΩ
	Integral Nonlinearity (INL)	-3.0	–	3.0	LSB	External V _{REF} = 3.0V; R _S <= 3.0kΩ
	DC Offset Error	-35	–	35	mV	

¹ Analog source impedance affects the ADC offset voltage (because of pin leakage) and input settling time.



Table 100. Analog-to-Digital Converter Electrical Characteristics and Timing (Continued)

Symbol	Parameter	$V_{DD} = 2.7 - 3.6V$ $T_A = -40^{\circ}C \text{ to } 105^{\circ}C$			Units	Conditions
		Minimum	Typical	Maximum		
V_{REF}	Internal Reference Voltage	1.8	2.0	2.55	V	
	Single-Shot Conversion Time	–	5129	–	cycles	System clock cycles
	Continuous Conversion Time	–	256	–	cycles	System clock cycles
	Sampling Rate	System Clock / 256			Hz	
	Signal Input Bandwidth	–	–	3.5	kHz	
R_S	Analog Source Impedance	–	–	10^1	k Ω	
Z_{in}	Input Impedance		150		k Ω	20MHz system clock. Input impedance increases with lower system clock frequency.
V_{REF}	External Reference Voltage			AVDD	V	AVDD \leq VDD. When using an external reference voltage, decoupling capacitance should be placed from VREF to AVSS.
I_{REF}	Current draw into VREF pin when driving with external source.		25.0	40.0	μA	

¹ Analog source impedance affects the ADC offset voltage (because of pin leakage) and input settling time.



General Purpose I/O Port Input Data Sample Timing

Figure 40 illustrates timing of the GPIO Port input sampling. The input value on a GPIO Port pin is sampled on the rising edge of the system clock. The Port value is then available to the eZ8 CPU on the second rising clock edge following the change of the Port value.

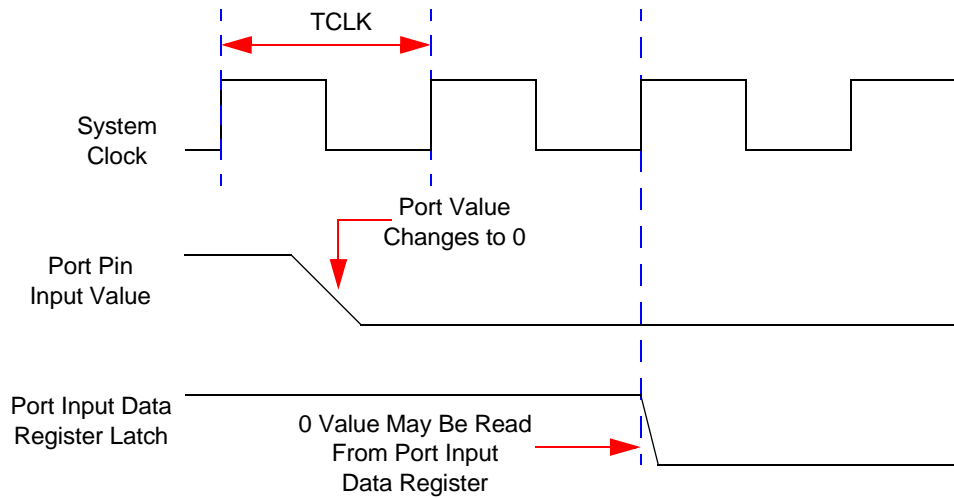

Figure 40. Port Input Sample Timing

Table 101. GPIO Port Input Timing

Parameter	Abbreviation	Delay (ns)	
		Min	Max
T _{S_PORT}	Port Input Transition to XIN Rise Setup Time (Not pictured)	5	–
T _{H_PORT}	XIN Rise to Port Input Transition Hold Time (Not pictured)	5	–
T _{SMR}	GPIO Port Pin Pulse Width to Insure STOP Mode Recovery (for GPIO Port Pins enabled as SMR sources)	1μs	

General Purpose I/O Port Output Timing

Figure 41 and Table 102 provide timing information for GPIO Port pins.

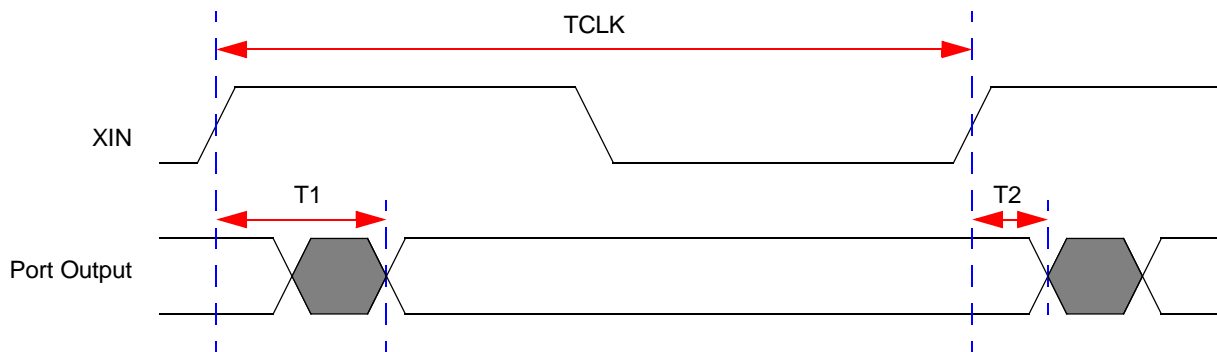

Figure 41. GPIO Port Output Timing

Table 102. GPIO Port Output Timing

Parameter	Abbreviation	Delay (ns)	
		Min	Max
GPIO Port pins			
T ₁	XIN Rise to Port Output Valid Delay	–	15
T ₂	XIN Rise to Port Output Hold Time	2	–

On-Chip Debugger Timing

Figure 42 and Table 103 provide timing information for the DBG pin. The DBG pin timing specifications assume a 4ns maximum rise and fall time.

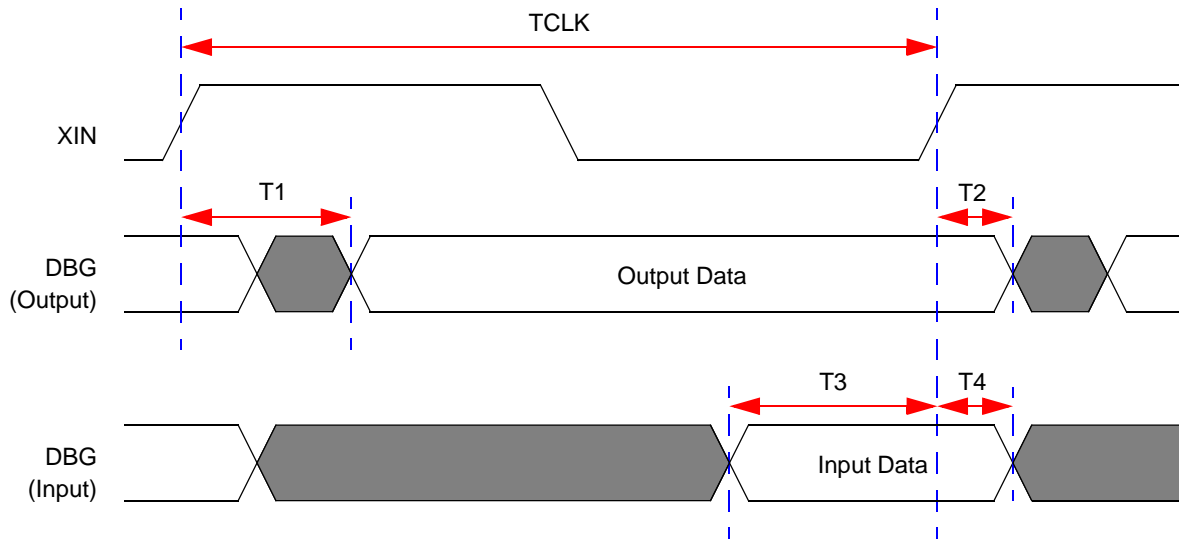

Figure 42. On-Chip Debugger Timing

Table 103. On-Chip Debugger Timing

Parameter	Abbreviation	Delay (ns)	
		Min	Max
DBG			
T ₁	XIN Rise to DBG Valid Delay	–	15
T ₂	XIN Rise to DBG Output Hold Time	2	–
T ₃	DBG to XIN Rise Input Setup Time	10	–
T ₄	DBG to XIN Rise Input Hold Time	5	–

SPI MASTER Mode Timing

Figure 43 and Table 104 provide timing information for SPI MASTER mode pins. Timing is shown with SCK rising edge used to source MOSI output data, SCK falling edge used to sample MISO input data. Timing on the SS output pin(s) is controlled by software.

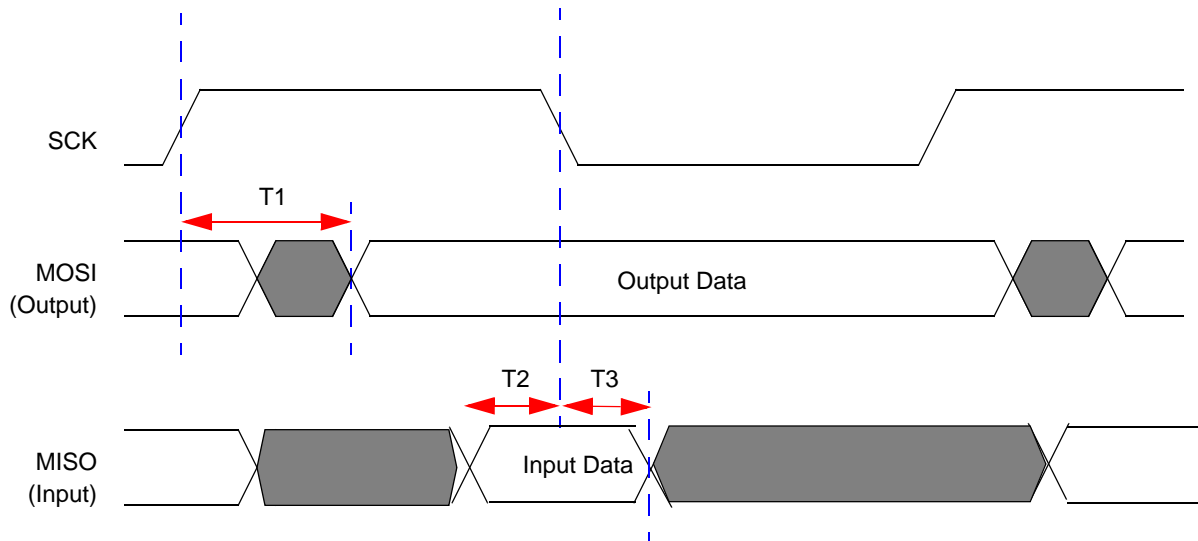

Figure 43. SPI MASTER Mode Timing

Table 104. SPI MASTER Mode Timing

Parameter	Abbreviation	Delay (ns)	
		Min	Max
SPI MASTER			
T_1	SCK Rise to MOSI output Valid Delay	-5	+5
T_2	MISO input to SCK (receive edge) Setup Time	20	
T_3	MISO input to SCK (receive edge) Hold Time	0	

SPI SLAVE Mode Timing

Figure 44 and Table 105 provide timing information for the SPI SLAVE mode pins. Timing is shown with SCK rising edge used to source MISO output data, SCK falling edge used to sample MOSI input data.

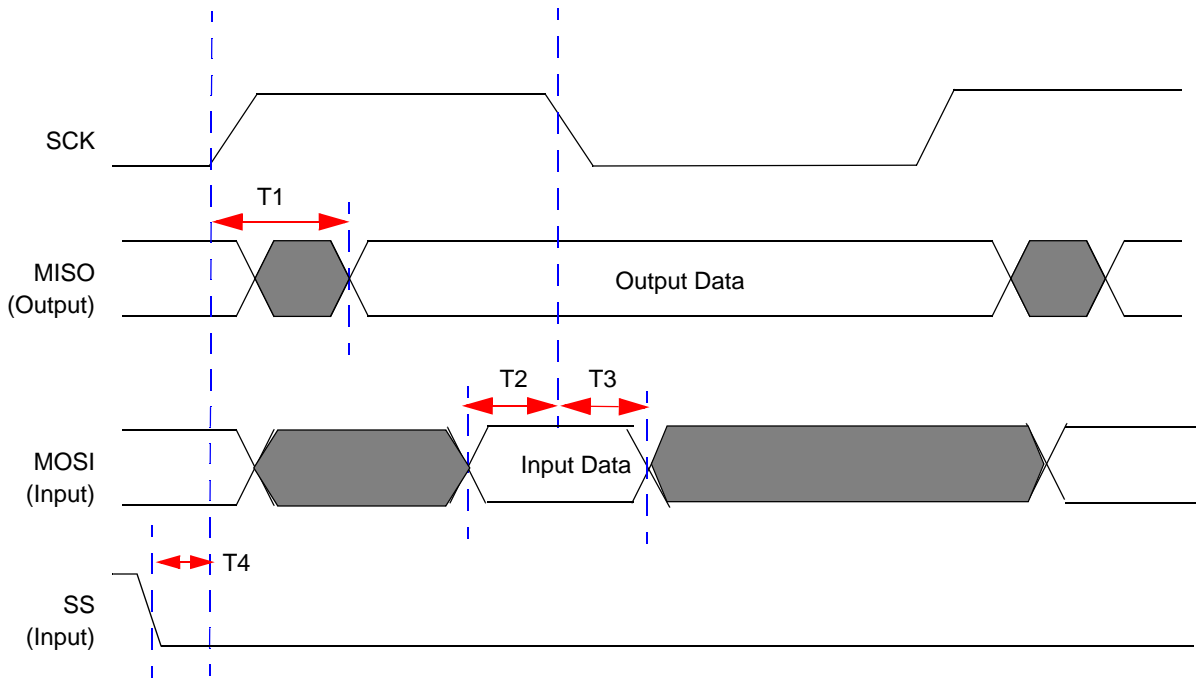

Figure 44. SPI SLAVE Mode Timing

Table 105. SPI SLAVE Mode Timing

Parameter	Abbreviation	Delay (ns)	
		Min	Max
SPI SLAVE			
T ₁	SCK (transmit edge) to MISO output Valid Delay	2 * X _{in} period	3 * X _{in} period + 20 nsec
T ₂	MOSI input to SCK (receive edge) Setup Time	0	
T ₃	MOSI input to SCK (receive edge) Hold Time	3 * X _{in} period	
T ₄	SS input assertion to SCK setup	1 * X _{in} period	

I²C Timing

Figure 45 and Table 106 provide timing information for I²C pins.

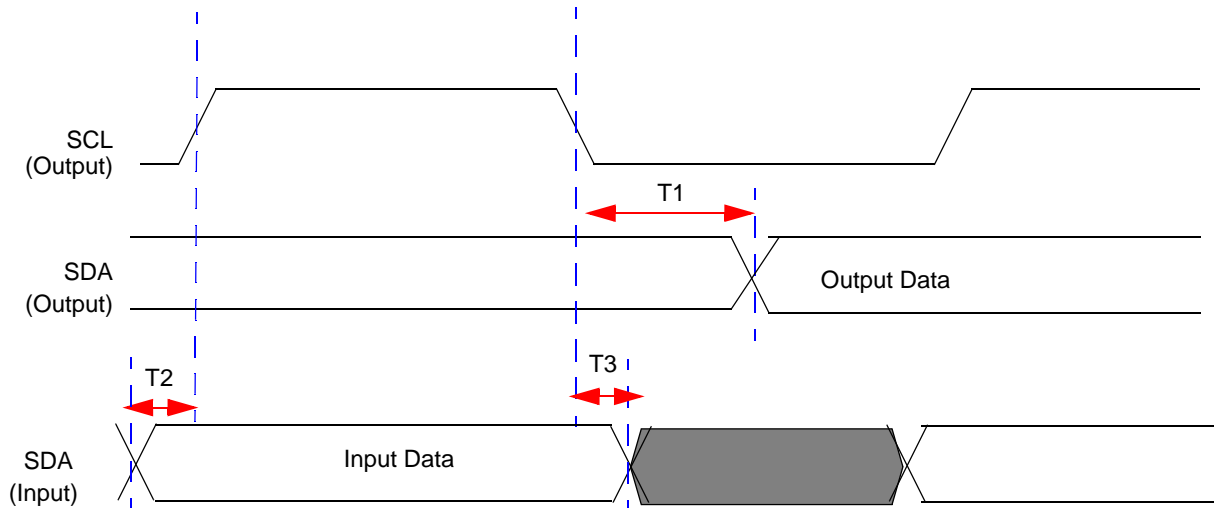

Figure 45. I²C Timing

Table 106. I²C Timing

Parameter	Abbreviation	Delay (ns)	
		Minimum	Maximum
I²C			
T ₁	SCL Fall to SDA output delay	SCL period/4	
T ₂	SDA Input to SCL rising edge Setup Time	0	
T ₃	SDA Input to SCL falling edge Hold Time	0	

UART Timing

Figure 46 and Table 107 provide timing information for UART pins for the case where CTS is used for flow control. The CTS to DE assertion delay (T1) assumes the transmit data register has been loaded with data prior to CTS assertion.

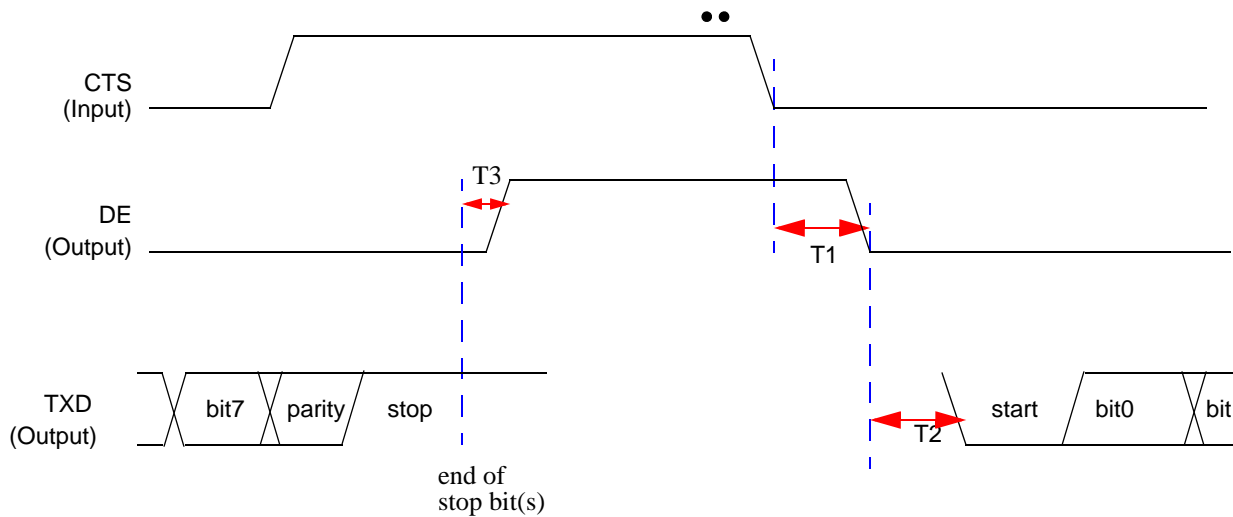

Figure 46. UART Timing with CTS

Table 107. UART Timing with CTS

Parameter	Abbreviation	Delay (ns)	
		Minimum	Maximum
UART			
T ₁	CTS Fall to DE output delay	2 * XIN period	2 * XIN period + 1 bit time
T ₂	DE assertion to TXD falling edge (start bit) delay		+/- 5
T ₃	End of Stop Bit(s) to DE deassertion delay		+/- 5

Figure 47 and Table 108 provide timing information for UART pins for the case where CTS is not used for flow control. DE asserts after the transmit data register has been written. DE remains asserted for multiple characters as long as the transmit data register is written with the next character before the current character has completed.

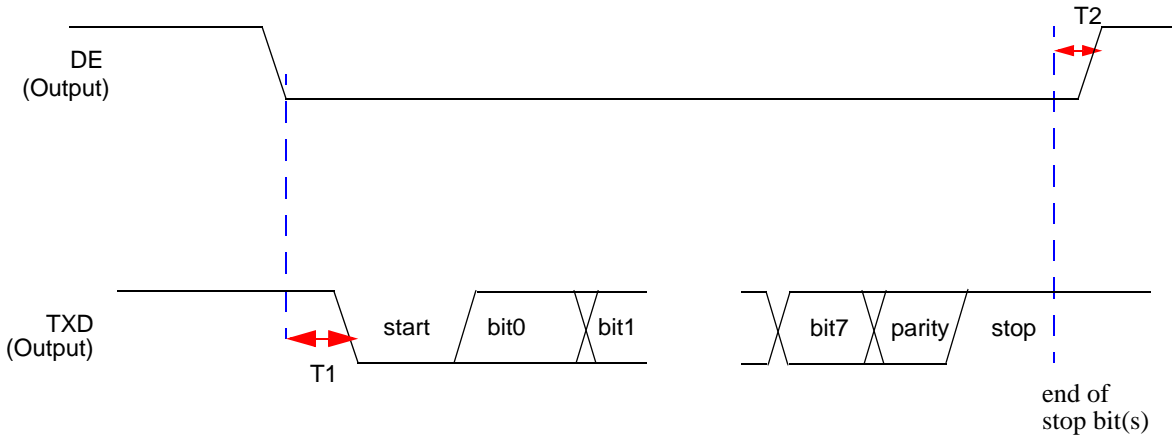

Figure 47. UART Timing without CTS

Table 108. UART Timing without CTS

Parameter	Abbreviation	Delay (ns)	
		Minimum	Maximum
UART			
T ₁	DE assertion to TXD falling edge (start bit) delay	1 * XIN period	1 bit time
T ₂	End of Stop Bit(s) to DE deassertion delay (Tx data register is empty)		+/- 5



eZ8 CPU Instruction Set

Assembly Language Programming Introduction

The eZ8 CPU assembly language provides a means for writing an application program without having to be concerned with actual memory addresses or machine instruction formats. A program written in assembly language is called a source program. Assembly language allows the use of symbolic addresses to identify memory locations. It also allows mnemonic codes (opcodes and operands) to represent the instructions themselves. The opcodes identify the instruction while the operands represent memory locations, registers, or immediate data values.

Each assembly language program consists of a series of symbolic commands called statements. Each statement can contain labels, operations, operands and comments.

Labels can be assigned to a particular instruction step in a source program. The label identifies that step in the program as an entry point for use by other instructions.

The assembly language also includes assembler directives that supplement the machine instruction. The assembler directives, or pseudo-ops, are not translated into a machine instruction. Rather, the pseudo-ops are interpreted as directives that control or assist the assembly process.

The source program is processed (assembled) by the assembler to obtain a machine language program called the object code. The object code is executed by the eZ8 CPU. An example segment of an assembly language program is detailed in the following example.

Assembly Language Source Program Example

```
JP START      ; Everything after the semicolon is a comment.

START:        ; A label called "START". The first instruction (JP START) in this
              ; example causes program execution to jump to the point within the
              ; program where the START label occurs.

LD R4, R7     ; A Load (LD) instruction with two operands. The first operand,
              ; Working Register R4, is the destination. The second operand,
              ; Working Register R7, is the source. The contents of R7 is
              ; written into R4.

LD 234H, #%01 ; Another Load (LD) instruction with two operands.
              ; The first operand, Extended Mode Register Address 234H,
              ; identifies the destination. The second operand, Immediate Data
```



; value 01H, is the source. The value 01H is written into the
; Register at address 234H.

Assembly Language Syntax

For proper instruction execution, eZ8 CPU assembly language syntax requires that the operands be written as ‘destination, source’. After assembly, the object code usually has the operands in the order ‘source, destination’, but ordering is opcode-dependent. The following instruction examples illustrate the format of some basic assembly instructions and the resulting object code produced by the assembler. This binary format must be followed by users that prefer manual program coding or intend to implement their own assembler.

Example 1: If the contents of Registers 43H and 08H are added and the result is stored in 43H, the assembly syntax and resulting object code is:

Table 109. Assembly Language Syntax Example 1

Assembly Language Code	ADD	43H	08H	(ADD dst, src)
Object Code	04	08	43	(OPC src, dst)

Example 2: In general, when an instruction format requires an 8-bit register address, that address can specify any register location in the range 0 - 255 or, using Escaped Mode Addressing, a Working Register R0 - R15. If the contents of Register 43H and Working Register R8 are added and the result is stored in 43H, the assembly syntax and resulting object code is:

Table 110. Assembly Language Syntax Example 2

Assembly Language Code	ADD	43H,	R8	(ADD dst, src)
Object Code	04	E8	43	(OPC src, dst)

See the device-specific Product Specification to determine the exact register file range available. The register file size varies, depending on the device type.

eZ8 CPU Instruction Notation

In the eZ8 CPU Instruction Summary and Description sections, the operands, condition codes, status flags, and address modes are represented by a notational shorthand that is described in Table 111

**Table 111. Notational Shorthand**

Notation	Description	Operand	Range
b	Bit	b	b represents a value from 0 to 7 (000B to 111B).
cc	Condition Code	—	See Condition Codes overview in the eZ8 CPU User Manual.
DA	Direct Address	Addr	Addr. represents a number in the range of 0000H to FFFFH
ER	Extended Addressing Register	Reg	Reg. represents a number in the range of 000H to FFFH
IM	Immediate Data	#Data	Data is a number between 00H to FFH
Ir	Indirect Working Register	@Rn	n = 0 – 15
IR	Indirect Register	@Reg	Reg. represents a number in the range of 00H to FFH
Irr	Indirect Working Register Pair	@RRp	p = 0, 2, 4, 6, 8, 10, 12, or 14
IRR	Indirect Register Pair	@Reg	Reg. represents an even number in the range 00H to FEH
p	Polarity	p	Polarity is a single bit binary value of either 0B or 1B.
r	Working Register	Rn	n = 0 – 15
R	Register	Reg	Reg. represents a number in the range of 00H to FFH
RA	Relative Address	X	X represents an index in the range of +127 to –128 which is an offset relative to the address of the next instruction
rr	Working Register Pair	RRp	p = 0, 2, 4, 6, 8, 10, 12, or 14
RR	Register Pair	Reg	Reg. represents an even number in the range of 00H to FEH
Vector	Vector Address	Vector	Vector represents a number in the range of 00H to FFH
X	Indexed	#Index	The register or register pair to be indexed is offset by the signed Index value (#Index) in a +127 to -128 range.

Table 112 contains additional symbols that are used throughout the Instruction Summary and Instruction Set Description sections.

**Table 112. Additional Symbols**

Symbol	Definition
dst	Destination Operand
src	Source Operand
@	Indirect Address Prefix
SP	Stack Pointer
PC	Program Counter
FLAGS	Flags Register
RP	Register Pointer
#	Immediate Operand Prefix
B	Binary Number Suffix
%	Hexadecimal Number Prefix
H	Hexadecimal Number Suffix

Assignment of a value is indicated by an arrow. For example,

$$\text{dst} \leftarrow \text{dst} + \text{src}$$

indicates the source data is added to the destination data and the result is stored in the destination location.



Condition Codes

The C, Z, S and V flags control the operation of the conditional jump (JP cc and JR cc) instructions. Sixteen frequently useful functions of the flag settings are encoded in a 4-bit field called the condition code (cc), which forms Bits 7:4 of the conditional jump instructions. The condition codes are summarized in Table 113. Some binary condition codes can be created using more than one assembly code mnemonic. The result of the flag test operation decides if the conditional jump is executed.

Table 113. Condition Codes

Binary	Hex	Assembly Mnemonic	Definition	Flag Test Operation
0000	0	F	Always False	–
0001	1	LT	Less Than	$(S \text{ XOR } V) = 1$
0010	2	LE	Less Than or Equal	$(Z \text{ OR } (S \text{ XOR } V)) = 1$
0011	3	ULE	Unsigned Less Than or Equal	$(C \text{ OR } Z) = 1$
0100	4	OV	Overflow	$V = 1$
0101	5	MI	Minus	$S = 1$
0110	6	Z	Zero	$Z = 1$
0110	6	EQ	Equal	$Z = 1$
0111	7	C	Carry	$C = 1$
0111	7	ULT	Unsigned Less Than	$C = 1$
1000	8	T (or blank)	Always True	–
1001	9	GE	Greater Than or Equal	$(S \text{ XOR } V) = 0$
1010	A	GT	Greater Than	$(Z \text{ OR } (S \text{ XOR } V)) = 0$
1011	B	UGT	Unsigned Greater Than	$(C = 0 \text{ AND } Z = 0) = 1$
1100	C	NOV	No Overflow	$V = 0$
1101	D	PL	Plus	$S = 0$
1110	E	NZ	Non-Zero	$Z = 0$
1110	E	NE	Not Equal	$Z = 0$
1111	F	NC	No Carry	$C = 0$
1111	F	UGE	Unsigned Greater Than or Equal	$C = 0$



eZ8 CPU Instruction Classes

eZ8 CPU instructions can be divided functionally into the following groups:

- Arithmetic
- Bit Manipulation
- Block Transfer
- CPU Control
- Load
- Logical
- Program Control
- Rotate and Shift

Tables 114 through 121 contain the instructions belonging to each group and the number of operands required for each instruction. Some instructions appear in more than one table as these instruction can be considered as a subset of more than one category. Within these tables, the source operand is identified as 'src', the destination operand is 'dst' and a condition code is 'cc'.

Table 114. Arithmetic Instructions

Mnemonic	Operands	Instruction
ADC	dst, src	Add with Carry
ADCX	dst, src	Add with Carry using Extended Addressing
ADD	dst, src	Add
ADDX	dst, src	Add using Extended Addressing
CP	dst, src	Compare
CPC	dst, src	Compare with Carry
CPCX	dst, src	Compare with Carry using Extended Addressing
CPX	dst, src	Compare using Extended Addressing
DA	dst	Decimal Adjust
DEC	dst	Decrement
DECW	dst	Decrement Word
INC	dst	Increment
INCW	dst	Increment Word
MULT	dst	Multiply

Table 114. Arithmetic Instructions (Continued)

Mnemonic	Operands	Instruction
SBC	dst, src	Subtract with Carry
SBCX	dst, src	Subtract with Carry using Extended Addressing
SUB	dst, src	Subtract
SUBX	dst, src	Subtract using Extended Addressing

Table 115. Bit Manipulation Instructions

Mnemonic	Operands	Instruction
BCLR	bit, dst	Bit Clear
BIT	p, bit, dst	Bit Set or Clear
BSET	bit, dst	Bit Set
BSWAP	dst	Bit Swap
CCF	—	Complement Carry Flag
RCF	—	Reset Carry Flag
SCF	—	Set Carry Flag
TCM	dst, src	Test Complement Under Mask
TCMX	dst, src	Test Complement Under Mask using Extended Addressing
TM	dst, src	Test Under Mask
TMX	dst, src	Test Under Mask using Extended Addressing

Table 116. Block Transfer Instructions

Mnemonic	Operands	Instruction
LDCI	dst, src	Load Constant to/from Program Memory and Auto-Increment Addresses
LDEI	dst, src	Load External Data to/from Data Memory and Auto-Increment Addresses

**Table 117. CPU Control Instructions**

Mnemonic	Operands	Instruction
CCF	—	Complement Carry Flag
DI	—	Disable Interrupts
EI	—	Enable Interrupts
HALT	—	HALT Mode
NOP	—	No Operation
RCF	—	Reset Carry Flag
SCF	—	Set Carry Flag
SRP	src	Set Register Pointer
STOP	—	STOP Mode
WDT	—	Watch-Dog Timer Refresh

Table 118. Load Instructions

Mnemonic	Operands	Instruction
CLR	dst	Clear
LD	dst, src	Load
LDC	dst, src	Load Constant to/from Program Memory
LDCI	dst, src	Load Constant to/from Program Memory and Auto-Increment Addresses
LDE	dst, src	Load External Data to/from Data Memory
LDEI	dst, src	Load External Data to/from Data Memory and Auto-Increment Addresses
LDX	dst, src	Load using Extended Addressing
LEA	dst, X(src)	Load Effective Address
POP	dst	Pop
POPX	dst	Pop using Extended Addressing
PUSH	src	Push
PUSHX	src	Push using Extended Addressing

Table 119. Logical Instructions

Mnemonic	Operands	Instruction
AND	dst, src	Logical AND
ANDX	dst, src	Logical AND using Extended Addressing
COM	dst	Complement
OR	dst, src	Logical OR
ORX	dst, src	Logical OR using Extended Addressing
XOR	dst, src	Logical Exclusive OR
XORX	dst, src	Logical Exclusive OR using Extended Addressing

Table 120. Program Control Instructions

Mnemonic	Operands	Instruction
BRK	—	On-Chip Debugger Break
BTJ	p, bit, src, DA	Bit Test and Jump
BTJNZ	bit, src, DA	Bit Test and Jump if Non-Zero
BTJZ	bit, src, DA	Bit Test and Jump if Zero
CALL	dst	Call Procedure
DJNZ	dst, src, RA	Decrement and Jump Non-Zero
IRET	—	Interrupt Return
JP	dst	Jump
JP cc	dst	Jump Conditional
JR	DA	Jump Relative
JR cc	DA	Jump Relative Conditional
RET	—	Return
TRAP	vector	Software Trap



Table 121. Rotate and Shift Instructions

Mnemonic	Operands	Instruction
BSWAP	dst	Bit Swap
RL	dst	Rotate Left
RLC	dst	Rotate Left through Carry
RR	dst	Rotate Right
RRC	dst	Rotate Right through Carry
SRA	dst	Shift Right Arithmetic
SRL	dst	Shift Right Logical
SWAP	dst	Swap Nibbles

eZ8 CPU Instruction Summary

Table 122 summarizes the eZ8 CPU instructions. The table identifies the addressing modes employed by the instruction, the effect upon the Flags register, the number of CPU clock cycles required for the instruction fetch, and the number of CPU clock cycles required for the instruction execution.

Table 122. eZ8 CPU Instruction Summary

Assembly Mnemonic	Symbolic Operation	Address Mode		Opcode(s) (Hex)	Flags						Fetch Cycles	Instr. Cycles
		dst	src		C	Z	S	V	D	H		
ADC dst, src	$dst \leftarrow dst + src + C$	r	r	12	*	*	*	*	0	*	2	3
		r	Ir	13							2	4
		R	R	14							3	3
		R	IR	15							3	4
		R	IM	16							3	3
		IR	IM	17							3	4
ADCX dst, src	$dst \leftarrow dst + src + C$	ER	ER	18	*	*	*	*	0	*	4	3
		ER	IM	19							4	3
Flags Notation:	* = Value is a function of the result of the operation. - = Unaffected X = Undefined				0 = Reset to 0 1 = Set to 1							



Table 122. eZ8 CPU Instruction Summary (Continued)

Assembly Mnemonic	Symbolic Operation	Address Mode		Opcode(s) (Hex)	Flags						Fetch Cycles	Instr. Cycles
		dst	src		C	Z	S	V	D	H		
ADD dst, src	dst ← dst + src	r	r	02	*	*	*	*	0	*	2	3
		r	Ir	03							2	4
		R	R	04							3	3
		R	IR	05							3	4
		R	IM	06							3	3
		IR	IM	07							3	4
ADDX dst, src	dst ← dst + src	ER	ER	08	*	*	*	*	0	*	4	3
		ER	IM	09							4	3
AND dst, src	dst ← dst AND src	r	r	52	-	*	*	0	-	-	2	3
		r	Ir	53							2	4
		R	R	54							3	3
		R	IR	55							3	4
		R	IM	56							3	3
		IR	IM	57							3	4
ANDX dst, src	dst ← dst AND src	ER	ER	58	-	*	*	0	-	-	4	3
		ER	IM	59							4	3
BCLR bit, dst	dst[bit] ← 0	r		E2	-	*	*	0	-	-	2	2
BIT p, bit, dst	dst[bit] ← p	r		E2	-	*	*	0	-	-	2	2
BRK	Debugger Break			00	-	-	-	-	-	-	1	1
BSET bit, dst	dst[bit] ← 1	r		E2	-	*	*	0	-	-	2	2
BSWAP dst	dst[7:0] ← dst[0:7]	R		D5	X	*	*	0	-	-	2	2
BTJ p, bit, src, dst	if src[bit] = p PC ← PC + X		r	F6	-	-	-	-	-	-	3	3
			Ir	F7							3	4
BTJNZ bit, src, dst	if src[bit] = 1 PC ← PC + X		r	F6	-	-	-	-	-	-	3	3
			Ir	F7							3	4
Flags Notation:	* = Value is a function of the result of the operation.				0 = Reset to 0							
	- = Unaffected				1 = Set to 1							
	X = Undefined											



Table 122. eZ8 CPU Instruction Summary (Continued)

Assembly Mnemonic	Symbolic Operation	Address Mode		Opcode(s) (Hex)	Flags						Fetch Cycles	Instr. Cycles
		dst	src		C	Z	S	V	D	H		
BTJZ bit, src, dst	if src[bit] = 0 PC ← PC + X		r	F6	-	-	-	-	-	-	3	3
			Ir	F7							3	4
CALL dst	SP ← SP - 2 @SP ← PC PC ← dst	IRR		D4	-	-	-	-	-	-	2	6
		DA		D6							3	3
CCF	C ← ~C			EF	*	-	-	-	-	-	1	2
CLR dst	dst ← 00H	R		B0	-	-	-	-	-	-	2	2
		IR		B1							2	3
COM dst	dst ← ~dst	R		60	-	*	*	0	-	-	2	2
		IR		61							2	3
CP dst, src	dst - src	r	r	A2	*	*	*	*	-	-	2	3
		r	Ir	A3							2	4
		R	R	A4							3	3
		R	IR	A5							3	4
		R	IM	A6							3	3
		IR	IM	A7							3	4
CPC dst, src	dst - src - C	r	r	1F A2	*	*	*	*	-	-	3	3
		r	Ir	1F A3							3	4
		R	R	1F A4							4	3
		R	IR	1F A5							4	4
		R	IM	1F A6							4	3
		IR	IM	1F A7							4	4
CPCX dst, src	dst - src - C	ER	ER	1F A8	*	*	*	*	-	-	5	3
		ER	IM	1F A9							5	3
CPX dst, src	dst - src	ER	ER	A8	*	*	*	*	-	-	4	3
		ER	IM	A9							4	3
Flags Notation:	* = Value is a function of the result of the operation.				0 = Reset to 0							
	- = Unaffected				1 = Set to 1							
	X = Undefined											



Table 122. eZ8 CPU Instruction Summary (Continued)

Assembly Mnemonic	Symbolic Operation	Address Mode		Opcode(s) (Hex)	Flags						Fetch Cycles	Instr. Cycles
		dst	src		C	Z	S	V	D	H		
DA dst	dst ← DA(dst)	R		40	*	*	*	X	-	-	2	2
		IR		41							2	3
DEC dst	dst ← dst - 1	R		30	-	*	*	*	-	-	2	2
		IR		31							2	3
DECW dst	dst ← dst - 1	RR		80	-	*	*	*	-	-	2	5
		IRR		81							2	6
DI	IRQCTL[7] ← 0			8F	-	-	-	-	-	-	1	2
DJNZ dst, RA	dst ← dst - 1 if dst ≠ 0 PC ← PC + X	r		0A-FA	-	-	-	-	-	-	2	3
EI	IRQCTL[7] ← 1			9F	-	-	-	-	-	-	1	2
HALT	HALT Mode			7F	-	-	-	-	-	-	1	2
INC dst	dst ← dst + 1	R		20	-	*	*	*	-	-	2	2
		IR		21							2	3
		r		0E-FE							1	2
INCW dst	dst ← dst + 1	RR		A0	-	*	*	*	-	-	2	5
		IRR		A1							2	6
IRET	FLAGS ← @SP SP ← SP + 1 PC ← @SP SP ← SP + 2 IRQCTL[7] ← 1			BF	*	*	*	*	*	*	1	5
JP dst	PC ← dst	DA		8D	-	-	-	-	-	-	3	2
		IRR		C4							2	3
JP cc, dst	if cc is true PC ← dst	DA		0D-FD	-	-	-	-	-	-	3	2
JR dst	PC ← PC + X	DA		8B	-	-	-	-	-	-	2	2
JR cc, dst	if cc is true PC ← PC + X	DA		0B-FB	-	-	-	-	-	-	2	2
Flags Notation:	* = Value is a function of the result of the operation.				0 = Reset to 0							
	- = Unaffected				1 = Set to 1							
	X = Undefined											



Table 122. eZ8 CPU Instruction Summary (Continued)

Assembly Mnemonic	Symbolic Operation	Address Mode		Opcode(s) (Hex)	Flags						Fetch Cycles	Instr. Cycles
		dst	src		C	Z	S	V	D	H		
LD dst, rc	dst ← src	r	IM	0C-FC	-	-	-	-	-	-	2	2
		r	X(r)	C7							3	3
		X(r)	r	D7							3	4
		r	Ir	E3							2	3
		R	R	E4							3	2
		R	IR	E5							3	4
		R	IM	E6							3	2
		IR	IM	E7							3	3
		Ir	r	F3							2	3
		IR	R	F5						3	3	
LDC dst, src	dst ← src	r	Irr	C2	-	-	-	-	-	-	2	5
		Ir	Irr	C5							2	9
		Irr	r	D2							2	5
LDCI dst, src	dst ← src r ← r + 1 rr ← rr + 1	Ir	Irr	C3	-	-	-	-	-	-	2	9
		Irr	Ir	D3							2	9
LDE dst, src	dst ← src	r	Irr	82	-	-	-	-	-	-	2	5
		Irr	r	92							2	5
LDEI dst, src	dst ← src r ← r + 1 rr ← rr + 1	Ir	Irr	83	-	-	-	-	-	-	2	9
		Irr	Ir	93							2	9
Flags Notation:	* = Value is a function of the result of the operation. - = Unaffected X = Undefined				0 = Reset to 0 1 = Set to 1							



Table 122. eZ8 CPU Instruction Summary (Continued)

Assembly Mnemonic	Symbolic Operation	Address Mode		Opcode(s) (Hex)	Flags						Fetch Cycles	Instr. Cycles
		dst	src		C	Z	S	V	D	H		
LDX dst, src	dst ← src	r	ER	84	-	-	-	-	-	-	3	2
		Ir	ER	85							3	3
		R	IRR	86							3	4
		IR	IRR	87							3	5
		r	X(rr)	88							3	4
		X(rr)	r	89							3	4
		ER	r	94							3	2
		ER	Ir	95							3	3
		IRR	R	96							3	4
		IRR	IR	97							3	5
		ER	ER	E8							4	2
		ER	IM	E9							4	2
LEA dst, X(src)	dst ← src + X	r	X(r)	98	-	-	-	-	-	-	3	3
		rr	X(rr)	99							3	5
MULT dst	dst[15:0] ← dst[15:8] * dst[7:0]	RR		F4	-	-	-	-	-	-	2	8
NOP	No operation			0F	-	-	-	-	-	-	1	2
OR dst, src	dst ← dst OR src	r	r	42	-	*	*	0	-	-	2	3
		r	Ir	43							2	4
		R	R	44							3	3
		R	IR	45							3	4
		R	IM	46							3	3
		IR	IM	47							3	4
ORX dst, src	dst ← dst OR src	ER	ER	48	-	*	*	0	-	-	4	3
		ER	IM	49							4	3
Flags Notation:	* = Value is a function of the result of the operation.				0 = Reset to 0							
	- = Unaffected				1 = Set to 1							
	X = Undefined											



Table 122. eZ8 CPU Instruction Summary (Continued)

Assembly Mnemonic	Symbolic Operation	Address Mode		Opcode(s) (Hex)	Flags						Fetch Cycles	Instr. Cycles
		dst	src		C	Z	S	V	D	H		
POP dst	dst ← @SP SP ← SP + 1	R		50	-	-	-	-	-	-	2	2
		IR		51							2	3
POPX dst	dst ← @SP SP ← SP + 1	ER		D8	-	-	-	-	-	-	3	2
PUSH src	SP ← SP - 1 @SP ← src	R		70	-	-	-	-	-	-	2	2
		IR		71							2	3
PUSHX src	SP ← SP - 1 @SP ← src	ER		C8	-	-	-	-	-	-	3	2
RCF	C ← 0			CF	0	-	-	-	-	-	1	2
RET	PC ← @SP SP ← SP + 2			AF	-	-	-	-	-	-	1	4
RL dst		R		90	*	*	*	*	-	-	2	2
		IR		91							2	3
RLC dst		R		10	*	*	*	*	-	-	2	2
		IR		11							2	3
RR dst		R		E0	*	*	*	*	-	-	2	2
		IR		E1							2	3
RRC dst		R		C0	*	*	*	*	-	-	2	2
		IR		C1							2	3
Flags Notation:	* = Value is a function of the result of the operation.				0 = Reset to 0							
	- = Unaffected				1 = Set to 1							
	X = Undefined											



Table 122. eZ8 CPU Instruction Summary (Continued)

Assembly Mnemonic	Symbolic Operation	Address Mode		Opcode(s) (Hex)	Flags						Fetch Cycles	Instr. Cycles
		dst	src		C	Z	S	V	D	H		
SBC dst, src	dst ← dst – src - C	r	r	32	*	*	*	*	1	*	2	3
		r	Ir	33							2	4
		R	R	34							3	3
		R	IR	35							3	4
		R	IM	36							3	3
		IR	IM	37							3	4
SBCX dst, src	dst ← dst – src - C	ER	ER	38	*	*	*	*	1	*	4	3
		ER	IM	39							4	3
SCF	C ← 1			DF	1	-	-	-	-	-	1	2
SRA dst		R		D0	*	*	*	0	-	-	2	2
		IR		D1							2	3
SRL dst		R		1F C0	*	*	0	*	-	-	3	2
		IR		1F C1							3	3
SRP src	RP ← src		IM	01	-	-	-	-	-	-	2	2
STOP	Stop Mode			6F	-	-	-	-	-	-	1	2
SUB dst, src	dst ← dst – src	r	r	22	*	*	*	*	1	*	2	3
		r	Ir	23							2	4
		R	R	24							3	3
		R	IR	25							3	4
		R	IM	26							3	3
		IR	IM	27							3	4
SUBX dst, src	dst ← dst – src	ER	ER	28	*	*	*	*	1	*	4	3
		ER	IM	29							4	3
SWAP dst	dst[7:4] ↔ dst[3:0]	R		F0	X	*	*	X	-	-	2	2
		IR		F1							2	3

Flags Notation: * = Value is a function of the result of the operation. 0 = Reset to 0
 - = Unaffected 1 = Set to 1
 X = Undefined

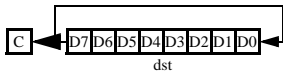
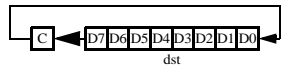
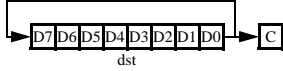
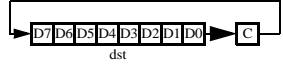

Table 122. eZ8 CPU Instruction Summary (Continued)

Assembly Mnemonic	Symbolic Operation	Address Mode		Opcode(s) (Hex)	Flags						Fetch Cycles	Instr. Cycles
		dst	src		C	Z	S	V	D	H		
TCM dst, src	(NOT dst) AND src	r	r	62	-	*	*	0	-	-	2	3
		r	Ir	63							2	4
		R	R	64							3	3
		R	IR	65							3	4
		R	IM	66							3	3
		IR	IM	67							3	4
TCMX dst, src	(NOT dst) AND src	ER	ER	68	-	*	*	0	-	-	4	3
		ER	IM	69							4	3
TM dst, src	dst AND src	r	r	72	-	*	*	0	-	-	2	3
		r	Ir	73							2	4
		R	R	74							3	3
		R	IR	75							3	4
		R	IM	76							3	3
		IR	IM	77							3	4
TMX dst, src	dst AND src	ER	ER	78	-	*	*	0	-	-	4	3
		ER	IM	79							4	3
TRAP Vector	SP ← SP – 2 @SP ← PC SP ← SP – 1 @SP ← FLAGS PC ← @Vector		Vector	F2	-	-	-	-	-	-	2	6
WDT				5F	-	-	-	-	-	-	1	2
Flags Notation:	* = Value is a function of the result of the operation. - = Unaffected X = Undefined							0 = Reset to 0 1 = Set to 1				



Table 122. eZ8 CPU Instruction Summary (Continued)

Assembly Mnemonic	Symbolic Operation	Address Mode		Opcode(s) (Hex)	Flags						Fetch Cycles	Instr. Cycles
		dst	src		C	Z	S	V	D	H		
XOR dst, src	dst ← dst XOR src	r	r	B2	-	*	*	0	-	-	2	3
		r	Ir	B3							2	4
		R	R	B4							3	3
		R	IR	B5							3	4
		R	IM	B6							3	3
		IR	IM	B7							3	4
XORX dst, src	dst ← dst XOR src	ER	ER	B8	-	*	*	0	-	-	4	3
		ER	IM	B9							4	3
Flags Notation:	* = Value is a function of the result of the operation.				0 = Reset to 0							
	- = Unaffected				1 = Set to 1							
	X = Undefined											

Flags Register

The Flags Register contains the status information regarding the most recent arithmetic, logical, bit manipulation or rotate and shift operation. The Flags Register contains six bits of status information that are set or cleared by CPU operations. Four of the bits (C, V, Z and S) can be tested with conditional jump instructions. Two flags (H and D) cannot be tested and are used for Binary-Coded Decimal (BCD) arithmetic.

The two remaining bits, User Flags (F1 and F2), are available as general-purpose status bits. User Flags are unaffected by arithmetic operations and must be set or cleared by instructions. The User Flags cannot be used with conditional Jumps. They are undefined at initial power-up and are unaffected by Reset. Figure 48 illustrates the flags and their bit positions in the Flags Register.

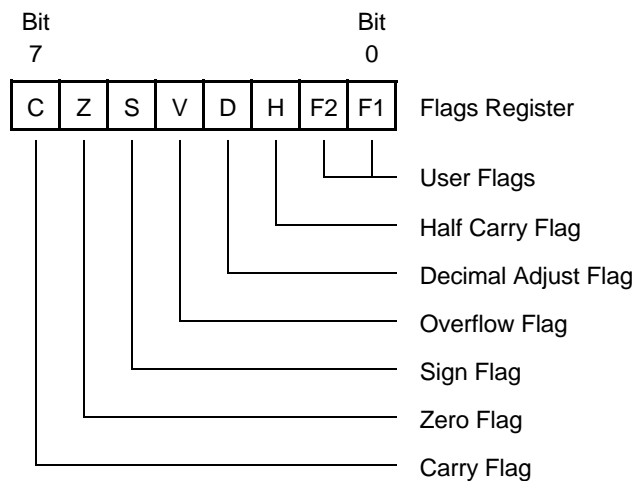

Figure 48. Flags Register

Interrupts, the Software Trap (TRAP) instruction, and Illegal Instruction Traps all write the value of the Flags Register to the stack. Executing an Interrupt Return (IRET) instruction restores the value saved on the stack into the Flags Register.



Opcode Maps

Figures 50 and 51 provide information on each of the eZ8 CPU instructions. A description of the opcode map data and the abbreviations are provided in Figure 49 and Table 123.

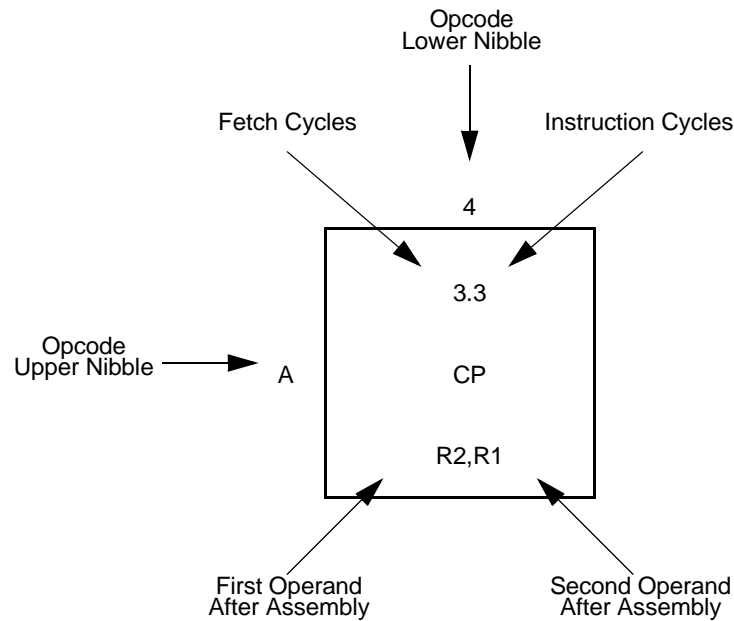

Figure 49. Opcode Map Cell Description

**Table 123. Opcode Map Abbreviations**

Abbreviation	Description	Abbreviation	Description
b	Bit position	IRR	Indirect Register Pair
cc	Condition code	p	Polarity (0 or 1)
X	8-bit signed index or displacement	r	4-bit Working Register
DA	Destination address	R	8-bit register
ER	Extended Addressing register	r1, R1, Ir1, Irr1, IR1, rr1, RR1, IRR1, ER1	Destination address
IM	Immediate data value	r2, R2, Ir2, Irr2, IR2, rr2, RR2, IRR2, ER2	Source address
Ir	Indirect Working Register	RA	Relative
IR	Indirect register	rr	Working Register Pair
Irr	Indirect Working Register Pair	RR	Register Pair



		Lower Nibble (Hex)																
		0	1	2	3	4	5	6	7	8	9	A	B	C	D	E	F	
Upper Nibble (Hex)	0	1.2 BRK	2.2 SRP IM	2.3 ADD r1,r2	2.4 ADD r1,lr2	3.3 ADD R2,R1	3.4 ADD IR2,R1	3.3 ADD R1,IM	3.4 ADD IR1,IM	4.3 ADDX ER2,ER1	4.3 ADDX IM,ER1	2.3 DJNZ r1,X	2.2 JR cc,X	2.2 LD r1,IM	3.2 JP cc,DA	1.2 INC r1	1.2 NOP	
	1	2.2 RLC R1	2.3 RLC IR1	2.3 ADC r1,r2	2.4 ADC r1,lr2	3.3 ADC R2,R1	3.4 ADC IR2,R1	3.3 ADC R1,IM	3.4 ADC IR1,IM	4.3 ADCX ER2,ER1	4.3 ADCX IM,ER1							See 2nd Opcode Map
	2	2.2 INC R1	2.3 INC IR1	2.3 SUB r1,r2	2.4 SUB r1,lr2	3.3 SUB R2,R1	3.4 SUB IR2,R1	3.3 SUB R1,IM	3.4 SUB IR1,IM	4.3 SUBX ER2,ER1	4.3 SUBX IM,ER1							
	3	2.2 DEC R1	2.3 DEC IR1	2.3 SBC r1,r2	2.4 SBC r1,lr2	3.3 SBC R2,R1	3.4 SBC IR2,R1	3.3 SBC R1,IM	3.4 SBC IR1,IM	4.3 SBCX ER2,ER1	4.3 SBCX IM,ER1							
	4	2.2 DA R1	2.3 DA IR1	2.3 OR r1,r2	2.4 OR r1,lr2	3.3 OR R2,R1	3.4 OR IR2,R1	3.3 OR R1,IM	3.4 OR IR1,IM	4.3 ORX ER2,ER1	4.3 ORX IM,ER1							
	5	2.2 POP R1	2.3 POP IR1	2.3 AND r1,r2	2.4 AND r1,lr2	3.3 AND R2,R1	3.4 AND IR2,R1	3.3 AND R1,IM	3.4 AND IR1,IM	4.3 ANDX ER2,ER1	4.3 ANDX IM,ER1							1.2 WDT
	6	2.2 COM R1	2.3 COM IR1	2.3 TCM r1,r2	2.4 TCM r1,lr2	3.3 TCM R2,R1	3.4 TCM IR2,R1	3.3 TCM R1,IM	3.4 TCM IR1,IM	4.3 TCMX ER2,ER1	4.3 TCMX IM,ER1							1.2 STOP
	7	2.2 PUSH R2	2.3 PUSH IR2	2.3 TM r1,r2	2.4 TM r1,lr2	3.3 TM R2,R1	3.4 TM IR2,R1	3.3 TM R1,IM	3.4 TM IR1,IM	4.3 TMX ER2,ER1	4.3 TMX IM,ER1							1.2 HALT
	8	2.5 DECW RR1	2.6 DECW IRR1	2.5 LDE r1,lr2	2.9 LDEI lr1,lr2	3.2 LDX r1,ER2	3.3 LDX lr1,ER2	3.4 LDX IRR2,R1	3.5 LDX IRR2,IR1	3.4 LDX r1,rr2,X	3.4 LDX rr1,rr2,X							1.2 DI
	9	2.2 RL R1	2.3 RL IR1	2.5 LDE r2,lr1	2.9 LDEI lr2,lr1	3.2 LDX r2,ER1	3.3 LDX lr2,ER1	3.4 LDX R2,IRR1	3.5 LDX IRR2,IRR1	3.3 LEA r1,rr2,X	3.5 LEA rr1,rr2,X							1.2 EI
	A	2.5 INCW RR1	2.6 INCW IRR1	2.3 CP r1,r2	2.4 CP r1,lr2	3.3 CP R2,R1	3.4 CP IR2,R1	3.3 CP R1,IM	3.4 CP IR1,IM	4.3 CPX ER2,ER1	4.3 CPX IM,ER1							1.4 RET
	B	2.2 CLR R1	2.3 CLR IR1	2.3 XOR r1,r2	2.4 XOR r1,lr2	3.3 XOR R2,R1	3.4 XOR IR2,R1	3.3 XOR R1,IM	3.4 XOR IR1,IM	4.3 XORX ER2,ER1	4.3 XORX IM,ER1							1.5 IRET
	C	2.2 RRC R1	2.3 RRC IR1	2.5 LDC r1,lr2	2.9 LDCI lr1,lr2	2.3 JP IRR1	2.9 LDC lr1,lr2		3.4 LD r1,rr2,X	3.2 PUSHX ER2								1.2 RCF
	D	2.2 SRA R1	2.3 SRA IR1	2.5 LDC r2,lr1	2.9 LDCI lr2,lr1	2.6 CALL IRR1	2.2 BSWAP R1	3.3 CALL DA	3.4 LD r2,r1,X	3.2 POPX ER1								1.2 SCF
	E	2.2 RR R1	2.3 RR IR1	2.2 BIT p,b,r1	2.3 LD r1,lr2	3.2 LD R2,R1	3.3 LD IR2,R1	3.3 LD R1,IM	3.3 LD IR1,IM	4.2 LDX ER2,ER1	4.2 LDX IM,ER1							1.2 CCF
	F	2.2 SWAP R1	2.3 SWAP IR1	2.6 TRAP Vector	2.3 LD lr1,lr2	2.8 MULT RR1	3.3 LD R2,IR1	3.3 BTJ p,b,r1,X	3.4 BTJ p,b,lr1,X									

Figure 50. First Opcode Map



		Lower Nibble (Hex)															
		0	1	2	3	4	5	6	7	8	9	A	B	C	D	E	F
Upper Nibble (Hex)	0																
	1																
	2																
	3																
	4																
	5																
	6																
	7																
	8																
	9																
	A			3.3 CPC r1,r2	3.4 CPC r1,lr2	4.3 CPC R2,R1	4.4 CPC IR2,R1	4.3 CPC R1,IM	4.4 CPC IR1,IM	5.3 CPCX ER2,ER1	5.3 CPCX IM,ER1						
	B																
	C	3.2 SRL R1	3.3 SRL IR1														
	D																
	E																
	F																

Figure 51. Second Opcode Map after 1FH



Packaging

Figure 52 illustrates the 20-pin SSOP package available for the Z8F0411, Z8F0421, Z8F0811, and Z8F0821 devices.

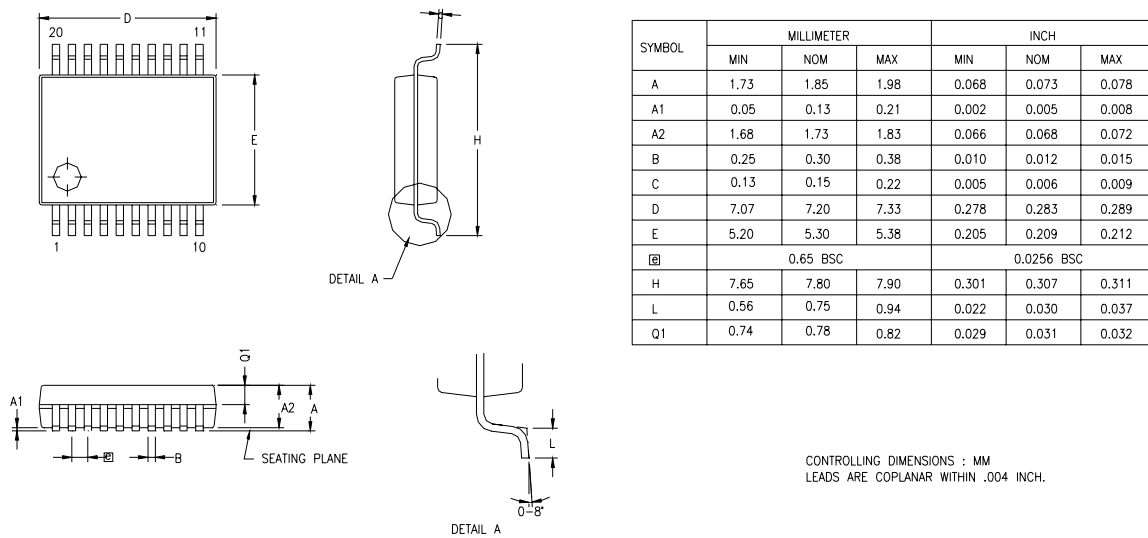

Figure 52. 20-Pin Small Shrink Outline Package (SSOP)



Figure 53 illustrates the 20-pin PDIP package available for the Z8F0411, Z8F0421, Z8F0811, and Z8F0821 devices.

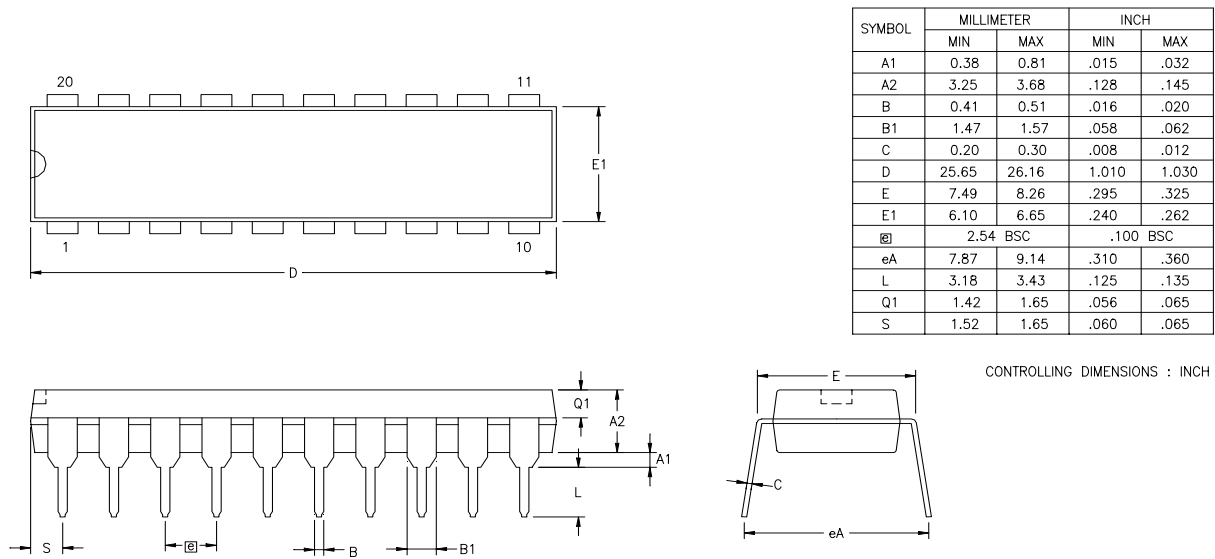

Figure 53. 20-Pin Plastic Dual-Inline Package (PDIP)



Figure 54 illustrates the 28-pin SOIC package available for the Z8F0412, Z8F0422, Z8F0812, and Z8F0822 devices.

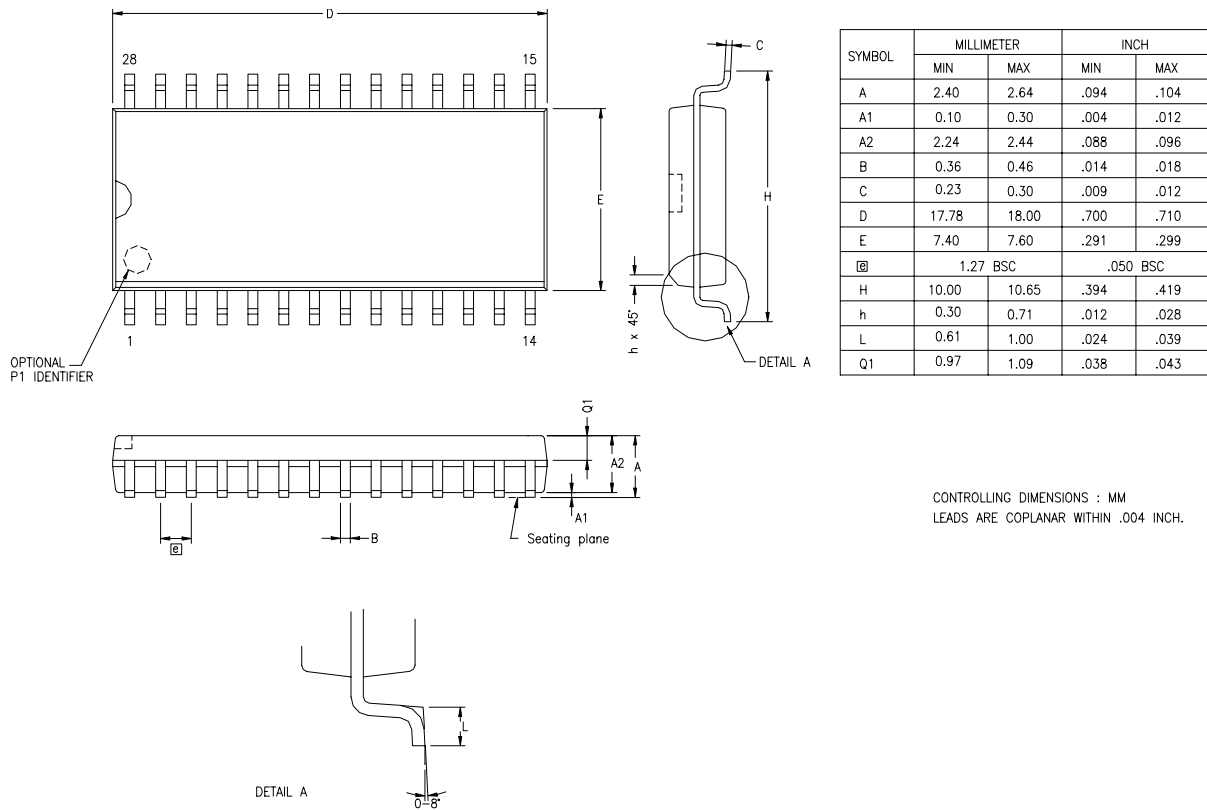
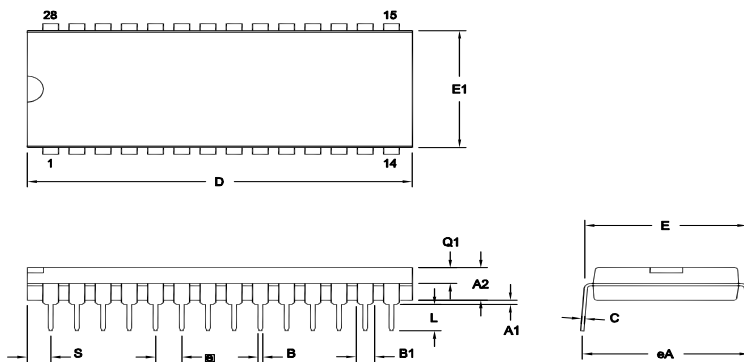

Figure 54. 28-Pin Small Outline Integrated Circuit Package (SOIC)



Figure 55 illustrates the 28-pin PDIP package available for the Z8F0412, Z8F0422, Z8F0812, and Z8F0822 devices.



SYMBOL	OPT #	MILLIMETER		INCH	
		MIN	MAX	MIN	MAX
A1		0.38	1.02	.015	.040
A2		3.18	4.19	.125	.165
B		0.38	0.63	.015	.021
B1	01	1.40	1.65	.055	.065
	02	1.14	1.40	.045	.055
C		0.23	0.38	.009	.015
D	01	36.58	37.34	1.440	1.470
	02	35.31	35.94	1.390	1.415
E		15.24	15.75	.600	.620
E1	01	13.59	14.10	.535	.555
	02	12.83	13.08	.505	.515
Ⓜ		2.54 TYP		.100 BSC	
eA		15.49	16.76	.610	.660
L		3.05	3.81	.120	.150
Q1	01	1.40	1.91	.055	.075
	02	1.40	1.78	.055	.070
S	01	1.52	2.29	.060	.090
	02	1.02	1.52	.040	.060

CONTROLLING DIMENSIONS : INCH

OPTION TABLE	
OPTION #	PACKAGE
01	STANDARD
02	IDF

Note: ZILOG supplies both options for production. Component layout PCB design should cover bigger option 01.

Figure 55. 28-Pin Plastic Dual-Inline Package (PDIP)



Ordering Information

Table 124. Ordering Information

Part	Flash KB (Bytes)	RAM KB (Bytes)	Max. Speed (MHz)	Temp (°C)	Voltage (V)	Package	Part Number
Z8 Encore!® with 8KB Flash and 10-Bit Analog-to-Digital Converter (Standard Temperature)							
Z8 Encore!®	8 (8192)	1 (1024)	20	0 to +70	2.7 - 3.6	SSOP-20	Z8F0821HH020SC
Z8 Encore!®	8 (8192)	1 (1024)	20	0 to +70	2.7 - 3.6	PDIP-20	Z8F0821PH020SC
Z8 Encore!®	8 (8192)	1 (1024)	20	0 to +70	2.7 - 3.6	SOIC-28	Z8F0822SJ020SC
Z8 Encore!®	8 (8192)	1 (1024)	20	0 to +70	2.7 - 3.6	PDIP-28	Z8F0822PJ020SC
Z8 Encore!® with 8KB Flash and 10-Bit Analog-to-Digital Converter (Extended Temperature)							
Z8 Encore!®	8 (8192)	1 (1024)	20	-40 to +105	2.7 - 3.6	SSOP-20	Z8F0821HH020EC
Z8 Encore!®	8 (8192)	1 (1024)	20	-40 to +105	2.7 - 3.6	PDIP-20	Z8F0821PH020EC
Z8 Encore!®	8 (8192)	1 (1024)	20	-40 to +105	2.7 - 3.6	SOIC-28	Z8F0822SJ020EC
Z8 Encore!®	8 (8192)	1 (1024)	20	-40 to +105	2.7 - 3.6	PDIP-28	Z8F0822PJ020EC
Z8 Encore!® with 8KB Flash (Standard Temperature)							
Z8 Encore!®	8 (8192)	1 (1024)	20	0 to +70	2.7 - 3.6	SSOP-20	Z8F0811HH020SC
Z8 Encore!®	8 (8192)	1 (1024)	20	0 to +70	2.7 - 3.6	PDIP-20	Z8F0811PH020SC
Z8 Encore!®	8 (8192)	1 (1024)	20	0 to +70	2.7 - 3.6	SOIC-28	Z8F0812SJ020SC
Z8 Encore!®	8 (8192)	1 (1024)	20	0 to +70	2.7 - 3.6	PDIP-28	Z8F0812PJ020SC
Z8 Encore!® with 8KB Flash (Extended Temperature)							
Z8 Encore!®	8 (8192)	1 (1024)	20	-40 to +105	2.7 - 3.6	SSOP-20	Z8F0811HH020EC
Z8 Encore!®	8 (8192)	1 (1024)	20	-40 to +105	2.7 - 3.6	PDIP-20	Z8F0811PH020EC
Z8 Encore!®	8 (8192)	1 (1024)	20	-40 to +105	2.7 - 3.6	SOIC-28	Z8F0812SJ020EC
Z8 Encore!®	8 (8192)	1 (1024)	20	-40 to +105	2.7 - 3.6	PDIP-28	Z8F0812PJ020EC



Table 124. Ordering Information (Continued)

Part	Flash KB (Bytes)	RAM KB (Bytes)	Max. Speed (MHz)	Temp (°C)	Voltage (V)	Package	Part Number
Z8 Encore!® with 4KB Flash and 10-Bit Analog-to-Digital Converter (Standard Temperature)							
Z8 Encore!®	4 (4096)	1 (1024)	20	0 to +70	2.7 - 3.6	SSOP-20	Z8F0421HH020SC
Z8 Encore!®	4 (4096)	1 (1024)	20	0 to +70	2.7 - 3.6	PDIP-20	Z8F0421PH020SC
Z8 Encore!®	4 (4096)	1 (1024)	20	0 to +70	2.7 - 3.6	SOIC-28	Z8F0422SJ020SC
Z8 Encore!®	4 (4096)	1 (1024)	20	0 to +70	2.7 - 3.6	PDIP-28	Z8F0422PJ020SC
Z8 Encore!® with 4KB Flash and 10-Bit Analog-to-Digital Converter (Extended Temperature)							
Z8 Encore!®	4 (4096)	1 (1024)	20	-40 to +105	2.7 - 3.6	SSOP-20	Z8F0421HH020EC
Z8 Encore!®	4 (4096)	1 (1024)	20	-40 to +105	2.7 - 3.6	PDIP-20	Z8F0421PH020EC
Z8 Encore!®	4 (4096)	1 (1024)	20	-40 to +105	2.7 - 3.6	SOIC-28	Z8F0422SJ020EC
Z8 Encore!®	4 (4096)	1 (1024)	20	-40 to +105	2.7 - 3.6	PDIP-28	Z8F0422PJ020EC
Z8 Encore!® with 4KB Flash (Standard Temperature)							
Z8 Encore!®	4 (4096)	1 (1024)	20	0 to +70	2.7 - 3.6	SSOP-20	Z8F0411HH020SC
Z8 Encore!®	4 (4096)	1 (1024)	20	0 to +70	2.7 - 3.6	PDIP-20	Z8F0411PH020SC
Z8 Encore!®	4 (4096)	1 (1024)	20	0 to +70	2.7 - 3.6	SOIC-28	Z8F0412SJ020SC
Z8 Encore!®	4 (4096)	1 (1024)	20	0 to +70	2.7 - 3.6	PDIP-28	Z8F0412PJ020SC
Z8 Encore!® with 4KB Flash (Extended Temperature)							
Z8 Encore!®	4 (4096)	1 (1024)	20	-40 to +105	2.7 - 3.6	SSOP-20	Z8F0411HH020EC
Z8 Encore!®	4 (4096)	1 (1024)	20	-40 to +105	2.7 - 3.6	PDIP-20	Z8F0411PH020EC
Z8 Encore!®	4 (4096)	1 (1024)	20	-40 to +105	2.7 - 3.6	SOIC-28	Z8F0412SJ020EC
Z8 Encore!®	4 (4096)	1 (1024)	20	-40 to +105	2.7 - 3.6	PDIP-28	Z8F0412PK020EC
Z8 Encore!® Evaluation Kit							
Z8F082x Evaluation Kit							Z8F08200100KIT

For valuable information about customer and technical support as well as hardware and software development tools, visit the ZiLOG web site at www.zilog.com. The latest released version of ZDS can be downloaded from this site.



Part Number Description

ZiLOG part numbers consist of a number of components, as indicated in the following examples:

ZiLOG Base Products	
Z8	ZiLOG 8-bit microcontroller product
F0821	Product Number
HH	Package
020	Speed
S	Temperature
C	Environmental Flow

Packages	HH = 20-pin SSOP PH = 20-pin PDIP SJ = 28-pin SOIC PJ = 28-pin PDIP
Speed	020 = 20 MHz
Temperature	S = 0°C to +70°C E = -40°C to +105°C
Environmental Flow	C = Plastic-Standard

For example, Part number Z8F0821HH020SC is an 8-bit microcontroller product in a 20-pin SSOP package, operating with a maximum 20-MHz external clock frequency over a 0°C to +70°C temperature range and built using the Plastic-Standard environmental flow.



Precharacterization Product

The product represented by this document is newly introduced and ZiLOG has not completed the full characterization of the product. The document states what ZiLOG knows about this product at this time, but additional features or nonconformance with some aspects of the document might be found, either by ZiLOG or its customers in the course of further application and characterization work. In addition, ZiLOG cautions that delivery might be uncertain at times, due to start-up yield issues.

ZiLOG, Inc.
532 Race Street
San Jose, CA 95126
Telephone (408) 558-8500
FAX 408 558-8300
Internet: www.zilog.com

Document Information

Document Number Description

The Document Control Number that appears in the footer on each page of this document contains unique identifying attributes, as indicated in the following table:

PS	Product Specification
0197	Unique Document Number
07	Revision Number
1003	Month and Year Published

Customer Feedback Form

The Z8 Encore!® Product Specification

If you experience any problems while operating this product, or if you note any inaccuracies while reading this Product Specification, please copy and complete this form, then mail or fax it to ZiLOG (see *Return Information*, below). We also welcome your suggestions!

Customer Information

Name	Country
Company	Phone
Address	Fax
City/State/Zip	E-Mail



Product Information

Part #, Serial #, Board Fab #, or Rev. #

Software Version

Document Number

Host Computer Description/Type

Return Information

ZiLOG
532 Race Street
San Jose, CA 95126
Fax: (408) 558-8536



Problem Description or Suggestion

Provide a complete description of the problem or your suggestion. If you are reporting a specific problem, include all steps leading up to the occurrence of the problem. Attach additional pages as necessary.

Index

Symbols

191
% 191
@ 191

Numerics

10-bit ADC 4
40-lead plastic dual-inline package 214

A

About This Manual xvi
absolute maximum ratings 171
AC characteristics 175
ADC 193
 architecture 133
 automatic power-down 134
 block diagram 134
 continuous conversion 135
 control register 136
 control register definitions 136
 data high byte register 137
 data low bits register 138
 electrical characteristics and timing 178
 operation 134
 single-shot conversion 134
ADCCTL register 136
ADCDH register 137
ADC DL register 138
ADCX 193
ADD 193
add - extended addressing 193
add with carry 193
add with carry - extended addressing 193
additional symbols 191
address space 13
ADDX 193
All Uppercase Letters, Use of xviii
analog signals 10

analog-to-digital converter (ADC) 133
AND 196
ANDX 196
arithmetic instructions 193
assembly language programming 188
assembly language syntax 189

B

B 191
b 190
baud rate generator, UART 91
BCLR 194
binary number suffix 191
BIT 194
bit 190
 clear 194
 manipulation instructions 194
 set 194
 set or clear 194
 swap 194
 test and jump 196
 test and jump if non-zero 196
 test and jump if zero 196
bit jump and test if non-zero 196
Bit Numbering xviii
bit swap 197
Bits and Similar Registers, Notation for xvii
block diagram 3
block transfer instructions 194
Braces xvii
Brackets xvi
BRK 196
BSET 194
BSWAP 194, 197
BTJ 196
BTJNZ 196
BTJZ 196

C

CALL procedure 196
capture mode 74
capture/compare mode 74



cc 190
CCF 195
characteristics, electrical 171
clear 195
clock phase (SPI) 110
CLR 195
COM 196
compare 74
compare - extended addressing 193
compare mode 74
compare with carry 193
compare with carry - extended addressing 193
complement 196
complement carry flag 194, 195
condition code 190
continuous conversion (ADC) 135
continuous mode 73
control register definition, UART 92
control register, I2C 129
counter modes 73
Courier Typeface xvi
CP 193
CPC 193
CPCX 193
CPU and peripheral overview 4
CPU control instructions 195
CPX 193
customer feedback form 219
customer information 219

D

DA 190, 193
data register, I2C 127
DC characteristics 173
debugger, on-chip 153
DEC 193
decimal adjust 193
decrement 193
decrement and jump non-zero 196
decrement word 193
DECW 193
destination operand 191
device, port availability 37

DI 195
direct address 190
disable interrupts 195
DJNZ 196
DMA
 controller 5
document number description 219
dst 191

E

EI 195
electrical characteristics 171
 ADC 178
 flash memory and timing 177
 GPIO input data sample timing 180
 watch-dog timer 178
enable interrupt 195
ER 190
extended addressing register 190
external pin reset 33
eZ8 CPU features 4
eZ8 CPU instruction classes 193
eZ8 CPU instruction notation 189
eZ8 CPU instruction set 188
eZ8 CPU instruction summary 197

F

FCTL register 145
features, Z8 Encore! 1
first opcode map 210
FLAGS 191
flags register 191
flash
 controller 4
 option bit address space 150
 option bit configuration - reset 150
 program memory address 0000H 151
 program memory address 0001H 152
flash memory 139
 arrangement 140
 byte programming 143
 code protection 142

- configurations 139
- control register definitions 145
- controller bypass 144
- electrical characteristics and timing 177
- flash control register 145
- flash status register 146
- frequency high and low byte registers 149
- mass erase 144
- operation 141
- operation timing 141
- page erase 144
- page select register 147

FPS register 147

FSTAT register 146

G

- gated mode 74
- general-purpose I/O 37
- GPIO 4, 37
 - alternate functions 38
 - architecture 37
 - control register definitions 40
 - input data sample timing 180
 - interrupts 39
 - port A-C pull-up enable sub-registers 45
 - port A-H address registers 40
 - port A-H alternate function sub-registers 42
 - port A-H control registers 41
 - port A-H data direction sub-registers 42
 - port A-H high drive enable sub-registers 44
 - port A-H input data registers 46
 - port A-H output control sub-registers 43
 - port A-H output data registers 47
 - port A-H stop mode recovery sub-registers 44
 - port availability by device 37
 - port input timing 180
 - port output timing 181

H

- H 191
- HALT 195
- halt mode 36, 195

- hexadecimal number prefix/suffix 191
- Hexadecimal Values xvi

I

- I2C 4
 - 10-bit address read transaction 126
 - 10-bit address transaction 124
 - 10-bit addressed slave data transfer format 124
 - 10-bit receive data format 126
 - 7-bit address transaction 123
 - 7-bit address, reading a transaction 125
 - 7-bit addressed slave data transfer format 123
 - 7-bit receive data transfer format 125
 - baud high and low byte registers 130, 132
 - C status register 128
 - control register definitions 127
 - controller 121
 - controller signals 9
 - interrupts 122
 - operation 121
 - SDA and SCL signals 121
 - stop and start conditions 122
- I2CBRH register 131, 132
- I2CBRL register 131
- I2CCTL register 129
- I2CDATA register 128
- I2CSTAT register 128
- IM 190
- immediate data 190
- immediate operand prefix 191
- INC 193
- increment 193
- increment word 193
- INCW 193
- indexed 190
- indirect address prefix 191
- indirect register 190
- indirect register pair 190
- indirect working register 190
- indirect working register pair 190
- infrared encoder/decoder (IrDA) 102
- Initial Uppercase Letters, Use of xvii
- instruction set, ez8 CPU 188



instructions

ADC 193
ADCX 193
ADD 193
ADDX 193
AND 196
ANDX 196
arithmetic 193
BCLR 194
BIT 194
bit manipulation 194
block transfer 194
BRK 196
BSET 194
BSWAP 194, 197
BTJ 196
BTJNZ 196
BTJZ 196
CALL 196
CCF 194, 195
CLR 195
COM 196
CP 193
CPC 193
CPCX 193
CPU control 195
CPX 193
DA 193
DEC 193
DECW 193
DI 195
DJNZ 196
EI 195
HALT 195
INC 193
INCW 193
IRET 196
JP 196
LD 195
LDC 195
LDCI 194, 195
LDE 195
LDEI 194
LDX 195

LEA 195
load 195
logical 196
MULT 193
NOP 195
OR 196
ORX 196
POP 195
POPX 195
program control 196
PUSH 195
PUSHX 195
RCF 194, 195
RET 196
RL 197
RLC 197
rotate and shift 197
RR 197
RRC 197
SBC 194
SCF 194, 195
SRA 197
SRL 197
SRP 195
STOP 195
SUB 194
SUBX 194
SWAP 197
TCM 194
TCMX 194
TM 194
TMX 194
TRAP 196
watch-dog timer refresh 195
XOR 196
XORX 196
instructions, eZ8 classes of 193
Intended Audience xvi
interrupt control register 59
interrupt controller 5, 48
 architecture 48
 interrupt assertion types 51
 interrupt vectors and priority 51
 operation 50



- register definitions 52
 - software interrupt assertion 51
- interrupt edge select register 58
- interrupt request 0 register 52
- interrupt request 1 register 53
- interrupt request 2 register 54
- interrupt return 196
- interrupt vector listing 48
- interrupts
 - not acknowledge 122
 - receive 122
 - SPI 113
 - transmit 122
 - UART 89
- introduction 1
- IR 190
- Ir 190
- IrDA
 - architecture 102
 - block diagram 102
 - control register definitions 106
 - operation 103
 - receiving data 104
 - transmitting data 103
- IRET 196
- IRQ0 enable high and low bit registers 55
- IRQ1 enable high and low bit registers 56
- IRQ2 enable high and low bit registers 57
- IRR 190
- Irr 190

J

- JP 196
- jump, conditional, relative, and relative conditional 196

L

- LD 195
- LDC 195
- LDCI 194, 195
- LDE 195
- LDEI 194, 195

- LDX 195
- LEA 195
- load 195
- load constant 194
- load constant to/from program memory 195
- load constant with auto-increment addresses 195
- load effective address 195
- load external data 195
- load external data to/from data memory and auto-increment addresses 194
- load external to/from data memory and auto-increment addresses 195
- load instructions 195
- load using extended addressing 195
- logical AND 196
- logical AND/extended addressing 196
- logical exclusive OR 196
- logical exclusive OR/extended addressing 196
- logical instructions 196
- logical OR 196
- logical OR/extended addressing 196
- low power modes 35
- LSB and MSB, Use of the Terms xvii

M

- Manual Conventions xvi
- Manual Objectives xvi
- master interrupt enable 50
- master-in, slave-out and-in 109
- memory
 - program 14
- MISO 109
- mode
 - capture 74
 - capture/compare 74
 - continuous 73
 - counter 73
 - gated 74
 - one-shot 73
 - PWM 73
- modes 74
- MOSI 109
- MULT 193



multiply 193
multiprocessor mode, UART 87

N

NOP (no operation) 195
not acknowledge interrupt 122
notation
 b 190
 cc 190
 DA 190
 ER 190
 IM 190
 IR 190
 Ir 190
 IRR 190
 Irr 190
 p 190
 R 190
 r 190
 RA 190
 RR 190
 rr 190
 vector 190
 X 190

notational shorthand 190

O

OCD

 architecture 153
 auto-baud detector/generator 156
 baud rate limits 156
 block diagram 153
 breakpoints 157
 commands 159
 control register 163
 data format 156
 DBG pin to RS-232 Interface 154
 debug mode 155
 debugger break 196
 interface 154
 serial errors 157
 status register 165

 timing 182

OCD commands

 execute instruction (12H) 163
 read data memory (0DH) 162
 read OCD control register (05H) 161
 read OCD revision (00H) 160
 read OCD status register (02H) 160
 read program counter (07H) 161
 read program memory (0BH) 162
 read program memory CRC (0EH) 163
 read register (09H) 161
 read runtime counter (03H) 160
 step instruction (10H) 163
 stuff instruction (11H) 163
 write data memory (0CH) 162
 write OCD control register (04H) 160
 write program counter (06H) 161
 write program memory (0AH) 162
 write register (08H) 161

on-chip debugger 5

on-chip debugger (OCD) 153

on-chip debugger signals 10

on-chip oscillator 167

one-shot mode 73

opcode map

 abbreviations 209

 cell description 208

 first 210

 second after 1FH 211

Operational Description 81

OR 196

ordering information 216

ORX 196

oscillator signals 10

P

p 190

packaging

 PDIP 214

Parentheses xvii

Parentheses/Bracket Combinations xvii

part number description 218

part selection guide 2



- PC 191
- PDIP 214
- peripheral AC and DC electrical characteristics 177
- PHASE=0 timing (SPI) 111
- PHASE=1 timing (SPI) 112
- pin characteristics 11
- polarity 190
- POP 195
- pop using extended addressing 195
- POPX 195
- port availability, device 37
- port input timing (GPIO) 180
- port output timing, GPIO 181
- power supply signals 11
- power-down, automatic (ADC) 134
- power-on and voltage brown-out 177
- power-on reset (POR) 30
- problem description or suggestion 221
- product information 220
- program control instructions 196
- program counter 191
- program memory 14
- PUSH 195
- push using extended addressing 195
- PUSHX 195
- PWM mode 73
- PxADDR register 40
- PxCTL register 41

- R**
- R 190
- r 190
- RA
 - register address 190
- RCF 194, 195
- receive
 - 10-bit data format (I2C) 126
 - 7-bit data transfer format (I2C) 125
 - IrDA data 104
- receive interrupt 122
- receiving UART data-interrupt-driven method 85
- receiving UART data-pollled method 85
- register 118, 190

- ADC control (ADCCTL) 136
- ADC data high byte (ADCDH) 137
- ADC data low bits (ADCDL) 138
- baud low and high byte (I2C) 130, 132
- baud rate high and low byte (SPI) 120
- control (SPI) 115
- control, I2C 129
- data, SPI 114
- flash control (FCTL) 145
- flash high and low byte (FFREQH and FRE-EQL) 149
- flash page select (FPS) 147
- flash status (FSTAT) 146
- GPIO port A-H address (PxADDR) 40
- GPIO port A-H alternate function sub-registers 42
- GPIO port A-H control address (PxCTL) 41
- GPIO port A-H data direction sub-registers 42
- I2C baud rate high (I2CBRH) 131, 132
- I2C control (I2CCTL) 129
- I2C data (I2CDATA) 128
- I2C status 128
- I2C status (I2CSTAT) 128
- I2Cbaud rate low (I2CBRL) 131
- mode, SPI 118
- OCD control 163
- OCD status 165
- SPI baud rate high byte (SPIBRH) 120
- SPI baud rate low byte (SPIBRL) 120
- SPI control (SPICTL) 115
- SPI data (SPIDATA) 115
- SPI status (SPISTAT) 117
- status, I2C 128
- status, SPI 116
- UARTx baud rate high byte (UxBRH) 99
- UARTx baud rate low byte (UxBRL) 99
- UARTx Control 0 (UxCTL0) 95, 98
- UARTx control 1 (UxCTL1) 97
- UARTx receive data (UxRXD) 93
- UARTx status 0 (UxSTAT0) 93
- UARTx status 1 (UxSTAT1) 95
- UARTx transmit data (UxTXD) 92
- watch-dog timer control (WDTCTL) 78
- watch-dog timer reload high byte (WDTH) 80

- watch-dog timer reload low byte (WDTL) 80
- watch-dog timer reload upper byte (WDTU) 79
- register file 13
- register file address map 16
- register pair 190
- register pointer 191
- reset
 - and stop mode characteristics 29
 - and stop mode recovery 29
 - carry flag 194
 - controller 5
 - sources 30
- RET 196
- return 196
- return information 220
- RL 197
- RLC 197
- rotate and shift instructions 197
- rotate left 197
- rotate left through carry 197
- rotate right 197
- rotate right through carry 197
- RP 191
- RR 190, 197
- rr 190
- RRC 197

- S**
- Safeguards xviii
- SBC 194
- SCF 194, 195
- SCK 109
- SDA and SCL (IrDA) signals 121
- second opcode map after 1FH 211
- serial clock 109
- serial peripheral interface (SPI) 107
- Set and Clear, Use of the Words xvii
- set carry flag 194, 195
- set register pointer 195
- shift right arithmetic 197
- shift right logical 197
- signal descriptions 9
- single-sho conversion (ADC) 134

- SIO 5
- slave data transfer formats (I2C) 124
- slave select 110
- software trap 196
- source operand 191
- SP 191
- SPI
 - architecture 107
 - baud rate generator 114
 - baud rate high and low byte register 120
 - clock phase 110
 - configured as slave 108
 - control register 115
 - control register definitions 114
 - data register 114
 - error detection 113
 - interrupts 113
 - mode fault error 113
 - mode register 118
 - multi-master operation 112
 - operation 108
 - overrun error 113
 - signals 109
 - single master, multiple slave system 108
 - single master, single slave system 107
 - status register 116
 - timing, PHASE = 0 111
 - timing, PHASE=1 112
- SPI controller signals 9
- SPI mode (SPIMODE) 118
- SPIBRH register 120
- SPIBRL register 120
- SPICTL register 115
- SPIDATA register 115
- SPIMODE register 118
- SPISTAT register 117
- SRA 197
- src 191
- SRL 197
- SRP 195
- SS, SPI signal 109
- stack pointer 191
- status register, I2C 128
- STOP 195



- stop mode 35, 195
- stop mode recovery
 - sources 33
 - using a GPIO port pin transition 34
 - using watch-dog timer time-out 33
- SUB 194
- subtract 194
- subtract - extended addressing 194
- subtract with carry 194
- subtract with carry - extended addressing 194
- SUBX 194
- SWAP 197
- swap nibbles 197
- symbols, additional 191
- system and core resets 30

T

- TCM 194
- TCMX 194
- test complement under mask 194
- test complement under mask - extended addressing 194
- test under mask 194
- test under mask - extended addressing 194
- timer signals 10
- timers 5, 60
 - architecture 60
 - block diagram 61
 - capture mode 65, 74
 - capture/compare mode 68, 74
 - compare mode 66, 74
 - continuous mode 62, 73
 - counter mode 63
 - counter modes 73
 - gated mode 67, 74
 - one-shot mode 61, 73
 - operating mode 61
 - PWM mode 64, 73
 - reading the timer count values 69
 - reload high and low byte registers 70
 - timer control register definitions 69
 - timer output signal operation 69
- timers 0-3

- control registers 73
 - high and low byte registers 69, 72
- TM 194
- TMX 194
- tools, hardware and software 217
- Trademarks xviii
- transmit
 - IrDA data 103
- transmit interrupt 122
- transmitting UART data-pollled method 83
- transmitting UART dat-interrupt-driven method 84
- TRAP 196

U

- UART 4
 - architecture 81
 - asynchronous data format without/with parity 83
 - baud rate generator 91
 - baud rates table 100
 - control register definitions 92
 - controller signals 9
 - data format 82
 - interrupts 89
 - multiprocessor mode 87
 - receiving data using interrupt-driven method 85
 - receiving data using the polled method 85
 - transmitting data using the interrupt-driven method 84
 - transmitting data using the polled method 83
 - x baud rate high and low registers 99
 - x control 0 and control 1 registers 95
 - x status 0 and status 1 registers 93, 95
- UxBRH register 99
- UxBRL register 99
- UxCTL0 register 95, 98
- UxCTL1 register 97
- UxRXD register 93
- UxSTAT0 register 93
- UxSTAT1 register 95
- UxTXD register 92



V

vector 190
voltage brown-out reset (VBR) 31

W

watch-dog timer
 approximate time-out delay 76
 approximate time-out delays 75
 CNTL 32
 control register 78
 electrical characteristics and timing 178
 interrupt in normal operation 76
 interrupt in stop mode 76
 operation 75
 refresh 76, 195
 reload unlock sequence 77
 reload upper, high and low registers 79
 reset 32
 reset in normal operation 77
 reset in STOP mode 77
 time-out response 76
WDTCTL register 78
WDTH register 80
WDTL register 80
working register 190
working register pair 190
WTDU register 79

X

X 190
XOR 196
XORX 196

Z

Z8 Encore!
 block diagram 3
 features 1
 introduction 1
 part selection guide 2

