



A **Littelfuse** Company

High-Performance 8-Bit Microcontrollers

Z8 Encore! XP[®] F6482 Series

Product Specification

PS029413-0921

PRELIMINARY



Warning: DO NOT USE THIS PRODUCT IN LIFE SUPPORT SYSTEMS.

LIFE SUPPORT POLICY

ZILOG'S PRODUCTS ARE NOT AUTHORIZED FOR USE AS CRITICAL COMPONENTS IN LIFE SUPPORT DEVICES OR SYSTEMS WITHOUT THE EXPRESS PRIOR WRITTEN APPROVAL OF THE PRESIDENT AND GENERAL COUNSEL OF ZILOG CORPORATION.

As used herein

Life support devices or systems are devices which (a) are intended for surgical implant into the body, or (b) support or sustain life and whose failure to perform when properly used in accordance with instructions for use provided in the labeling can be reasonably expected to result in a significant injury to the user. A critical component is any component in a life support device or system whose failure to perform can be reasonably expected to cause the failure of the life support device or system or to affect its safety or effectiveness.

Document Disclaimer

©2021 Zilog, Inc. All rights reserved. Information in this publication concerning the devices, applications, or technology described is intended to suggest possible uses and may be superseded. Zilog, INC. DOES NOT ASSUME LIABILITY FOR OR PROVIDE A REPRESENTATION OF ACCURACY OF THE INFORMATION, DEVICES, OR TECHNOLOGY DESCRIBED IN THIS DOCUMENT. Zilog ALSO DOES NOT ASSUME LIABILITY FOR INTELLECTUAL PROPERTY INFRINGEMENT RELATED IN ANY MANNER TO USE OF INFORMATION, DEVICES, OR TECHNOLOGY DESCRIBED HEREIN OR OTHERWISE. The information contained within this document has been verified according to the general principles of electrical and mechanical engineering.

Z8, Z8 Encore!, Z8 Encore! XP, and ZMOTION are registered trademarks of Zilog, Inc. All other product or service names are the property of their respective owners.

Revision History

Each instance in the following revision history table reflects a change to this document from its previous version. For more details, refer to the corresponding pages or appropriate links provided in the table.

Date	Revision Level	Description	Page
Aug 2021	13	<p>Updated FLEN (FLL enable) bit to be disable by System Reset.</p> <p>Clarified that PortD0/RESET is not a Stop Mode Recovery source.</p> <p>Enhanced UART noise filter description. Corrected Noise Filter Operation figure.</p> <p>Updated USB Bulk Out Transfers Section to include information and a caution regarding USB buffer space accesses.</p> <p>Updated ADC Starting and Stopping Conversions Section.</p> <p>Clarified ADC offset compensation and updated ADC gain compensation formula.</p> <p>Added Development System Overview Section.</p> <p>Updated DAC Offset Error parameter.</p> <p>Added Comparator hysteresis definition.</p> <p>Updated Op Amp Input Offset and Gain Tolerance parameters.</p> <p>Dropped DCO tempco, DCO voltco, and FLL Lock Time parameters.</p> <p>Corrected typos and updated logo.</p>	<p>39, 110, 120</p> <p>57, 90</p> <p>255</p> <p>349</p> <p>445</p> <p>451</p> <p>561</p> <p>612</p> <p>614</p> <p>617</p> <p>626</p> <p>various</p>
Jun 2018	12	Removed Z8F6481AT024XK2247 (80-pin LQFP) from the ZMOTION Library Series Ordering Information table.	636

Apr 2017	11	<p>Corrected typos in pins 9 and 10 of the 32-pin QFN pinout. 13</p> <p>Corrected RTC_DOW, RTC_DOM, RTC_ADOW, RTC_ADOM addresses. 28-29</p> <p>Added information regarding IRQE in Stop Mode. 50</p> <p>Updated description of PWRCTL1[3:2] regarding control of the ADC and ADC voltage reference. 54</p> <p>Clarified SEEDSEL usage for DCO. 109, 121</p> <p>Corrected R/W capability of the TxNFC registers. 186</p> <p>Corrected counter mode descriptions for RTC_DOW, RTC_DOM, RTC_ADOW, RTC_ADOM. 211, 217, 226, 227</p> <p>Updated Event In power line selection 212, 228</p> <p>Added I2C baud rate generator information for the case of the I2C configured as a general purpose timer 334</p> <p>Clarified stopping ADC conversions when SCAN, CONTCONV or AVE are set. 445</p> <p>Updated description of ADC wake-up 447, 449</p> <p>Changed minimum ADC ST value from 1 clock to 2 clocks. 461</p> <p>Described the effect of setting Op Amp A or Op Amp B OPOWER bit. 476, 482, 484</p> <p>Clarified OCD block diagram. 560</p> <p>Removed VBO and LVD pulse rejection periods. 606, 619</p> <p>Updated DCO resolution and DCO control word resolution. 626</p> <p>Add ZMOTION ordering part numbers 636</p>
May 2016	10	<p>Added information about External Pad on the QFN package and clarification about AVDD and AVSS power supply in Table 4. 21, 22</p>
Apr 2016	09	<p>Corrected part number typos in Table 356. 633</p>
Mar 2016	08	<p>Added 44-pin QFN package information to Table 16, Table 356, and Table 358. 55, 633, 638</p>
Jan 2016	07	<p>Corrected Figure 6, 80-pin LQFP. 17</p>
Dec 2015	06	<p>Clarified the 64-pin package size (10mm x 10mm). 632</p>

Nov 2015	05	<p>Added 44-pin Quad Flat No Lead (QFN) packaging option.</p> <p>RTC. Changed LSB in counter mode to DOW.</p> <p>Clarified INPCAP functionality in Dual Input Triggered One-Shot Mode and Gated Mode.</p> <p>Updated 14-bit ADC conversion to be recommended for differential mode only.</p> <p>Indicated that the Op Amp B IRESSEL = 11 setting is not recommended for $AV_{DD} < 3V$.</p> <p>ADC electrical parameters. Added RESOLUT=1 (14-bit resolution) INL/DNL specs. Reduced maximum INMODE=0x ADC Clock frequency to 2MHz. Reduced maximum RESOLUT=1 ADC Clock frequency to 2MHz.</p> <p>Added ST and SST parameters for INMODE=1x at POWER=10 (low)</p> <p>Corrected typos.</p>	<p>12, 14, 632</p> <p>211, 217, 218</p> <p>155, 165, 180</p> <p>441, 445, 608</p> <p>479, 484, 608</p> <p>various</p>
Oct 2014	04	<p>Corrected pin 10 to ESOUT1 from ESOUT0, Figure 2; corrected “P3” values for pins 32 and 33 to “PE”, Figure 3; corrected PB3 value for Pin 53 to PB4, Figure 6; modified description in System Clock Source Switching and PCLK Source Switching sections; clarified description for the ADCREF bit, Table 15; corrected subscripted terms in Frequency Locked Loop and Phase Locked Loop sections; corrected Figure 24 timer output values to T4CH0, T4CH1; clarified description in WDT Interrupt in Normal Operation, WDT Interrupt in Stop Mode, and WDT Reset in Stop Mode sections; clarified IEC definition, DALI Protocol Mode section; modified Bit 7 description, Table 204; corrected overline issue to depict active status of Timers 0, 1, and 2, Table 217; added note, Channel Scanning section; modified description, Starting and Stopping Conversions section and the Automatic and Manual Wake-Up subsections of the Starting and Stopping Conversions section; modified description, ADC Timing section; modified description, ADC Wake-up, Sampling, and Settling section; clarified description, Calibration and Compensation section; modified offset calibration description for bits 7:6, Table 236; modified GAIN values, bits 7:4, Table 253; modified VBIAS descriptions, Reference System Operation section; modified description of Bit 7, Table 257; corrected ADC Output (Hex) value for 0°C from BC1 to B1C, Table 262; modified T_{WAKE_AR} parameter description and T_{WAKE_ADC} conditions, Table 337; modified GAIN_TOL values and conditions, Table 342.</p>	<p>13, 14, 17, 54, 100, 102, 109, 112, 194, 207, 243, 400, 413, 444, 445, 447, 449, 451, 452, 482, 491, 494, 501, 608, 617</p>
Dec 2013	03	<p>Updated UART-LDD, USB, Option Bits, and Electrical Characteristics chapters.</p>	<p>230, 340, 542, 601</p>
May 2013	02	<p>Corrected to include PRELIMINARY in footer per Zilog style.</p>	<p>n/a</p>
May 2013	01	<p>Original issue.</p>	<p>n/a</p>



Table of Contents

Revision History	iii
Table of Contents	vi
List of Figures	xxii
List of Tables	xxvi
Chapter 1. Overview	1
1.1. Features	1
1.2. Part Selection Guide	2
1.3. Block Diagram	4
1.4. eZ8 CPU and Peripheral Overview	5
1.4.1. General-Purpose Input/Output	5
1.4.2. Flash Controller	5
1.4.3. Non-Volatile Data Storage	5
1.4.4. Clock System	6
1.4.5. 12-Bit Analog-to-Digital Converter	6
1.4.6. 12-Bit Digital-to-Analog Converter	6
1.4.7. Low-Power Operational Amplifiers	6
1.4.8. Analog Comparators	7
1.4.9. Temperature Sensor	7
1.4.10. Low-Voltage Detector	7
1.4.11. USB 2.0	7
1.4.12. Enhanced SPI	7
1.4.13. UART with LIN, DALI, and DMX	7
1.4.14. Master/Slave I ² C	7
1.4.15. Liquid Crystal Display	8
1.4.16. Advanced Encryption Standard	8
1.4.17. Timers	8
1.4.18. Multi-Channel Timer	8
1.4.19. Real-Time Clock	8
1.4.20. Interrupt Controller	9
1.4.21. Reset Controller	9
1.4.22. On-Chip Debugger	9
1.4.23. Direct Memory Access Controller	9
1.4.24. Event System	9
1.5. Acronyms and Expansions	9



Chapter 2. Pin Description	12
2.1. Available Packages	12
2.2. Pin Configurations	12
2.3. Signal Descriptions	18
2.4. Pin Characteristics	22
Chapter 3. Address Space	24
3.1. Register File	24
3.2. Program Memory	24
3.3. Data Memory	26
3.4. Flash Information Area	26
Chapter 4. Register Map	27
Chapter 5. Reset, Stop-Mode Recovery and Low-Voltage Detection	38
5.1. Reset Types	38
5.2. System Reset	39
5.2.1. Power-On Reset	40
5.2.2. Voltage Brown-Out Reset	42
5.2.3. Watchdog Timer Reset	43
5.2.4. External Reset Input	43
5.2.5. External Reset Indicator	44
5.2.6. On-Chip Debugger Initiated Reset	44
5.3. Stop-Mode Recovery	44
5.3.1. Stop-Mode Recovery Using Watchdog Timer Time-Out	46
5.3.2. Stop-Mode Recovery Using Timer, Comparator, RTC, or LVD Interrupt	46
5.3.3. Stop-Mode Recovery Using GPIO Port Pin Transition	47
5.3.4. Stop-Mode Recovery Using External RESET Pin	47
5.4. Low-Voltage Detection	47
5.5. Reset Register Definitions	48
Chapter 6. Low-Power Modes	50
6.1. Stop Mode	50
6.2. Halt Mode	51
6.3. Peripheral-Level Power Control	52
6.4. Power Control Register Definitions	52
6.4.1. Power Control Register 0	52
6.4.2. Power Control Register 1	54
Chapter 7. General-Purpose Input/Output	55
7.1. GPIO Port Availability by Device	55



- 7.2. Architecture 56
- 7.3. GPIO Alternate Functions 56
- 7.4. Shared Reset Pin 57
- 7.5. High Frequency Crystal Oscillator Override 57
- 7.6. Low Frequency Crystal Oscillator Override 57
- 7.7. External Clock Setup 57
- 7.8. Port Alternate Function Mapping 58
- 7.9. GPIO Interrupts 85
- 7.10. GPIO Control Register Definitions 85
 - 7.10.1. Port A–J Address Registers 86
 - 7.10.2. Port A–J Control Registers 87
 - 7.10.3. Port A–J Data Direction Subregisters 87
 - 7.10.4. Port A–J Alternate Function Subregisters 88
 - 7.10.5. Port A–J Output Control Subregisters 88
 - 7.10.6. Port A–J High Drive Enable Subregisters 89
 - 7.10.7. Port A–G Stop-Mode Recovery Source Enable Subregisters
90
 - 7.10.8. Port A–J Pull-up Enable Subregisters 91
 - 7.10.9. Port A–G Alternate Function Set 1 Subregisters 92
 - 7.10.10. Port C Alternate Function Set 2 Subregister 93
 - 7.10.11. Port A–J Input Data Registers 94
 - 7.10.12. Port A–J Output Data Register 95
- Chapter 8. Clock System 96
 - 8.1. Architecture 97
 - 8.2. Clock Selection 98
 - 8.2.1. System Clock Selection 98
 - 8.2.2. Peripheral Clock Selection 101
 - 8.2.3. PLL Clock Selection 102
 - 8.2.4. Clock System Control Register Unlocking/Locking 103
 - 8.3. Clock Failure Detection and Recovery 103
 - 8.3.1. System Clock Failure 103
 - 8.3.2. Watchdog Timer Failure 104
 - 8.4. High Frequency Crystal Oscillator 104
 - 8.4.1. Operating Modes 105
 - 8.4.2. HFXO Operation 105
 - 8.5. Low Frequency Crystal Oscillator 106
 - 8.5.1. LFXO Operation 106
 - 8.6. Internal Precision Oscillator 107
 - 8.6.1. Operation 107



8.7.	Watchdog Timer Oscillator	108
8.8.	Digitally Controlled Oscillator	108
8.8.1.	Operating Modes	108
8.8.2.	DCO Operation	108
8.9.	Frequency Locked Loop	109
8.9.1.	Operating Modes	109
8.9.2.	FLL Operation	110
8.10.	Phase Locked Loop	112
8.10.1.	Operation	112
8.11.	Clock System Register Definitions	114
8.11.1.	Clock Control 0 Register	114
8.11.2.	Clock Control 1 Register	116
8.11.3.	Clock Control 2 Register	117
8.11.4.	Clock Control 3 Register	118
8.11.5.	Clock Control 4 Register	119
8.11.6.	Clock Control 5 Register	120
8.11.7.	Clock Control 6 Register	121
8.11.8.	Clock Control 7 Register	122
8.11.9.	Clock Control 8 Register	122
8.11.10.	Clock Control 9 Register	123
8.11.11.	Clock Control A Register	123
8.11.12.	Clock Control B Register	125
8.11.13.	Clock Control C Register	126
Chapter 9.	Interrupt Controller	127
9.1.	Interrupt Vector Listing	127
9.2.	Architecture	130
9.3.	Operation	130
9.3.1.	Master Interrupt Enable	130
9.3.2.	Interrupt Vectors and Priority	131
9.3.3.	Interrupt Assertion	131
9.3.4.	Software Interrupt Assertion	132
9.4.	Interrupt Control Register Definitions	132
9.4.1.	Interrupt Request 0 Register	132
9.4.2.	Interrupt Request 1 Register	134
9.4.3.	Interrupt Request 2 Register	135
9.4.4.	Interrupt Request 3 Register	136
9.4.5.	IRQ0 Enable High and Low Bit Registers	137
9.4.6.	IRQ1 Enable High and Low Bit Registers	139
9.4.7.	IRQ2 Enable High and Low Bit Registers	140



9.4.8.	IRQ3 Enable High and Low Bit Registers	142
9.4.9.	Interrupt Edge Select Register	145
9.4.10.	Shared Interrupt Select Register 0	146
9.4.11.	Shared Interrupt Select Register 1	147
9.4.12.	Interrupt Control Register	148
Chapter 10.	Timers	149
10.1.	Timer Architecture	150
10.2.	Timer Operation	150
10.2.1.	Timer Clock Source	150
10.2.2.	Low-Power Modes	151
10.2.3.	Timer Operating Modes	152
10.2.4.	Reading the Timer Count Values	170
10.2.5.	Timer Interrupts and DMA	170
10.2.6.	Timer Output Signal Operation	171
10.2.7.	Timer Input Path and Noise Filter	171
10.3.	Timer Register Definitions	174
10.3.1.	Timer 0–2 High and Low Byte Registers	175
10.3.2.	Timer Reload High and Low Byte Registers	176
10.3.3.	Timer 0–2 PWM0 High and Low Byte Registers	177
10.3.4.	Timer 0–2 PWM1 High and Low Byte Registers	178
10.3.5.	Timer 0–2 Control Registers	179
10.3.6.	Timer 0–2 Status Registers	185
10.3.7.	Timer 0–2 Noise Filter Control Registers	186
Chapter 11.	Multi-Channel Timer	187
11.1.	Architecture	187
11.2.	Timer Operation	188
11.2.1.	Multi-Channel Timer Counter	188
11.2.2.	Inputs and Outputs	188
11.2.3.	Clock Source	189
11.2.4.	Multi-Channel Timer Clock Prescaler	189
11.2.5.	Multi-Channel Timer Start	189
11.2.6.	Multi-Channel Timer Mode Control	189
11.2.7.	Count Modulo Mode	190
11.2.8.	Count Up/Down Mode	190
11.3.	Capture/Compare Channel Operation	191
11.3.1.	One-Shot Compare Operation	191
11.3.2.	Continuous Compare Operation	191
11.3.3.	PWM Output Operation	191
11.3.4.	Capture Operation	192



11.4.	Multi-Channel Timer Interrupts and DMA	192
11.4.1.	Timer Interrupt	192
11.4.2.	Channel Interrupts	192
11.4.3.	DMA	192
11.5.	Low-Power Modes	193
11.5.1.	Operation in Halt Mode	193
11.5.2.	Operation in Stop Mode	193
11.5.3.	Power Reduction During Operation	193
11.6.	Multi-Channel Timer Application Examples	193
11.6.1.	PWM Programmable Deadband Generation	193
11.6.2.	Multiple Timer Intervals Generation	194
11.7.	Multi-Channel Timer Control Register Definitions	195
11.7.1.	Multi-Channel Timer Address Map	195
11.7.2.	Multi-Channel Timer High and Low Byte Registers	196
11.7.3.	MCT Reload High and Low Byte Registers	197
11.7.4.	MCT Subaddress Register	198
11.7.5.	MCT Subregister x	199
11.7.6.	Multi-Channel Timer Control 0 and Control 1 Registers	199
11.7.7.	Multi-Channel Timer Channel Status 0 and Status 1 Registers	202
11.7.8.	Multi-Channel Timer Channel-y Control Registers	203
11.7.9.	Multi-Channel Timer Channel-y High and Low Byte Registers	205
Chapter 12.	Watchdog Timer	206
12.1.	Operation	206
12.1.1.	Watchdog Timer Retrigger	207
12.1.2.	Watchdog Timer Time-Out Response	207
12.1.3.	Watchdog Timer Reload Unlock Sequence	208
12.2.	Watchdog Timer Register Definitions	208
12.2.1.	Watchdog Timer Reload High and Low Byte Registers	208
Chapter 13.	Real-Time Clock	210
13.1.	Architecture	210
13.2.	Operation	211
13.2.1.	Calendar Mode Operation	211
13.2.2.	Counter Mode Operation	211
13.2.3.	Real-Time Clock Alarm	211
13.2.4.	Real-Time Clock Source Selection	211
13.2.5.	Synchronous Reading of the Real Time Clock Counts	212
13.2.6.	Real-Time Clock Recommended Operation	212



13.2.7.	Real-Time Clock Enable and Count Register Writing . . .	212
13.3.	Real-Time Clock Control Register Definitions	213
13.3.1.	Real-Time Clock Seconds Register	213
13.3.2.	Real-Time Clock Minutes Register	214
13.3.3.	Real-Time Clock Hours Register	215
13.3.4.	Real-Time Clock Day-of-the-Month Register	216
13.3.5.	Real-Time Clock Day-of-the-Week Register	218
13.3.6.	Real-Time Clock Month Register	219
13.3.7.	Real-Time Clock Year Register	220
13.3.8.	Real-Time Clock Alarm Seconds Register	221
13.3.9.	Real-Time Clock Alarm Minutes Register	222
13.3.10.	Real-Time Clock Alarm Hours Register	223
13.3.11.	Real-Time Clock Alarm Day-of-the-Month Register . . .	224
13.3.12.	Real-Time Clock Alarm Day-of-the-Week Register . . .	225
13.3.13.	Real-Time Clock Alarm Control Register	226
13.3.14.	Real-Time Clock Timing Register	227
13.3.15.	Real-Time Clock Control Register	228
Chapter 14.	UART-LDD	230
14.1.	UART-LDD Architecture	231
14.1.1.	Data Format for Standard UART Modes	232
14.1.2.	Transmitting Data using the Polled Method	232
14.1.3.	Transmitting Data Using Interrupt-Driven Method	233
14.1.4.	Receiving Data Using Polled Method	234
14.1.5.	Receiving Data Using the Interrupt-Driven Method	235
14.1.6.	Clear To Send Operation	236
14.1.7.	External Driver Enable	236
14.1.8.	UART-LDD Special Modes	237
14.1.9.	Multiprocessor Mode	237
14.1.10.	LIN Protocol Mode	239
14.1.11.	DALI Protocol Mode	243
14.1.12.	DMX Protocol Mode	247
14.1.13.	UART-LDD Interrupts	250
14.1.14.	UART-LDD and DMA Support	254
14.1.15.	UART-LDD Baud Rate Generator	254
14.2.	Noise Filter	255
14.2.1.	Architecture	255
14.2.2.	Operation	256
14.3.	UART-LDD Control Register Definitions	258
14.3.1.	UART-LDD 0–1 Transmit Data Registers	258
14.3.2.	UART-LDD 0–1 Receive Data Registers	258



14.3.3.	UART-LDD 0–1 Status 0 Registers	259
14.3.4.	UART-LDD 0–1 Mode Select and Status Registers	264
14.3.5.	UART-LDD 0–1 Control 0 Registers	267
14.3.6.	UART-LDD 0–1 Control 1 Registers	269
14.3.7.	Noise Filter Control Registers	271
14.3.8.	LIN Control Registers	272
14.3.9.	DALI Control Registers	273
14.3.10.	DMX Control Registers	274
14.3.11.	UART-LDD Address Compare Registers	275
14.3.12.	UART-LDD 0–1 Baud Rate High and Low Byte Registers	276
Chapter 15. Enhanced Serial Peripheral Interface		281
15.1.	Architecture	281
15.2.	ESPI Signals	283
15.2.1.	Master-In/Slave-Out	283
15.2.2.	Master-Out/Slave-In	283
15.2.3.	Serial Clock	283
15.2.4.	Slave Select	283
15.3.	Operation	284
15.3.1.	Throughput	285
15.3.2.	ESPI Clock Phase and Polarity Control	285
15.3.3.	Slave Select Modes of Operation	287
15.3.4.	SPI Protocol Configuration	289
15.3.5.	Error Detection	292
15.3.6.	ESPI Interrupts	293
15.3.7.	ESPI and DMA	294
15.3.8.	ESPI Baud Rate Generator	294
15.4.	ESPI Control Register Definitions	295
15.4.1.	ESPI 0-1 Data Registers	295
15.4.2.	ESPI 0-1 Transmit Data Command Registers	296
15.4.3.	ESPI 0-1 Control Registers	297
15.4.4.	ESPI 0-1 Mode Registers	299
15.4.5.	ESPI 0-1 Status Registers	301
15.4.6.	ESPI 0-1 State Registers	302
15.4.7.	ESPI 0-1 Baud Rate High and Low Byte Registers	303
Chapter 16. I ² C Master/Slave Controller		306
16.1.	Architecture	306
16.1.1.	I ² C Master/Slave Controller Registers	307
16.2.	Operation	308



16.2.1.	SDA and SCL Signals	308
16.2.2.	I ² C Interrupts	309
16.2.3.	Start and Stop Conditions	311
16.2.4.	Software Control of I ² C Transactions	311
16.2.5.	Master Transactions	311
16.2.6.	Slave Transactions	319
16.2.7.	DMA Control of I ² C Transactions	326
16.3.	I ² C Control Register Definitions	329
16.3.1.	I ² C Data Register	329
16.3.2.	I ² C Interrupt Status Register	330
16.3.3.	I ² C Control Register	331
16.3.4.	I ² C Baud Rate High and Low Byte Registers	332
16.3.5.	I ² C State Register	334
16.3.6.	I ² C Mode Register	337
16.3.7.	I ² C Slave Address Register	339
Chapter 17.	Universal Serial Bus	340
17.1.	Architecture	340
17.2.	Operation	341
17.2.1.	Overview of USB Registers and Subregisters	341
17.2.2.	USB Endpoint Buffer Memory	341
17.2.3.	USB Module Setup	344
17.2.4.	USB Control Transfers Using Endpoint 0	345
17.2.5.	USB Transfers Using Endpoints 1–3	348
17.2.6.	Endpoint Pairing	350
17.2.7.	USB Transfer Control	351
17.2.8.	Suspend/Resume	352
17.2.9.	Stop Mode Operation	354
17.2.10.	USB Module Interrupts and DMA	355
17.3.	USB Control Register Definitions	356
17.3.1.	USB Subaddress Register	357
17.3.2.	USB Subdata Register	359
17.3.3.	USB Control Register	360
17.3.4.	USB DMA 0–1 Control Registers	361
17.3.5.	USB DMA Data Register	362
17.3.6.	USB Interrupt Control Register	363
17.3.7.	USB OUT Endpoint 1–3 Start Address Subregisters	364
17.3.8.	USB IN Endpoints Start Address Subregister	365
17.3.9.	USB IN Endpoint 1–3 Start Address Subregisters	366
17.3.10.	USB Clock Gate Subregister	367
17.3.11.	USB Interrupt Identification Subregister	368



17.3.12.	USB IN Interrupt Request Subregister	369
17.3.13.	USB OUT Interrupt Request Subregister	370
17.3.14.	USB Protocol Interrupt Request Subregister	371
17.3.15.	USB IN Interrupt Enable Subregister	372
17.3.16.	USB OUT Interrupt Enable Subregister	373
17.3.17.	USB Protocol Interrupt Enable Subregister	374
17.3.18.	USB Endpoint 0 Control and Status Subregister	375
17.3.19.	USB IN 0–3 Byte Count Subregisters	376
17.3.20.	USB IN 1–3 Control and Status Subregister	377
17.3.21.	USB OUT 0–3 Byte Count Subregisters	378
17.3.22.	USB OUT 1–3 Control and Status Subregisters	379
17.3.23.	USB Control and Status Subregister	380
17.3.24.	USB Toggle Control Subregister	381
17.3.25.	USB Frame Count Subregisters	382
17.3.26.	USB Function Address Subregister	384
17.3.27.	USB Endpoint Pairing Subregister	385
17.3.28.	USB IN Endpoint Valid Subregister	386
17.3.29.	USB OUT Endpoint Valid Subregister	387
17.3.30.	USB IN Endpoints Stop Address Subregister	388
17.3.31.	USB Setup Buffer Byte 0–7 Subregisters	389
Chapter 18.	Direct Memory Access Controller	390
18.1.	Architecture	390
18.2.	Operation	391
18.2.1.	DMA Registers and Subregisters	392
18.2.2.	Address Control	392
18.2.3.	DMA Request Selection	392
18.2.4.	Transfer Types	393
18.2.5.	Direct Operation	393
18.2.6.	Linked List Operation	394
18.2.7.	Global Disable	397
18.2.8.	DMA Channel Priority	397
18.2.9.	Interrupts	398
18.2.10.	End-of-Count Interrupt	398
18.2.11.	Watermark Interrupt	398
18.3.	DMA Control Register Definitions	399
18.3.1.	DMA 0–3 Subaddress/Status Registers	400
18.3.2.	DMA 0–3 Subdata Registers	401
18.3.3.	DMA Global Control Register	402
18.3.4.	DMA Source Address Subregisters	403
18.3.5.	DMA Destination Address Subregisters	404



18.3.6.	DMA Count Subregisters	406
18.3.7.	DMA 0–3 Control 0 Subregisters	407
18.3.8.	DMA 0–3 Control 1 Subregisters	408
18.3.9.	DMA 0–3 Linked List Descriptor Address High and Low Subregisters	410
Chapter 19.	Event System	411
19.1.	Architecture	411
19.2.	Source Selection	412
19.3.	Destination Selection	414
19.4.	Timing Considerations	415
19.5.	Event System Usage Examples	415
19.6.	Event System Register Definitions	417
19.6.1.	Event System Source Subaddress Register	418
19.6.2.	Event System Source Subdata Register	419
19.6.3.	Event System Channel 0–7 Source Subregisters	420
19.6.4.	Event System Destination Subaddress Register	421
19.6.5.	Event System Destination Subdata Register	422
19.6.6.	Event System Destination 0–3F Channel Subregisters	423
Chapter 20.	Advanced Encryption Standard (AES) Accelerator	424
20.1.	AES Architecture	424
20.2.	AES Operation	425
20.2.1.	AES Operation and DMA	427
20.2.2.	AES Electronic Codebook (ECB) Mode	427
20.2.3.	Initialization Vector	429
20.2.4.	AES Output Feedback (OFB) Mode	430
20.2.5.	AES Cipher Block Chaining (CBC) Mode	432
20.2.6.	Decrypt Key Derivation	434
20.3.	AES Register Definitions	434
20.3.1.	AES Data Register	435
20.3.2.	Initialization Vector Register	436
20.3.3.	Key Register	436
20.3.4.	AES Control Register	437
20.3.5.	AES Status Register	438
Chapter 21.	Analog-to-Digital Converter	439
21.1.	Architecture	439
21.2.	Operation	440
21.2.1.	Input Modes	441
21.2.2.	ADC Data Format	442



21.2.3.	Conversion Options	444
21.2.4.	Starting and Stopping Conversions	445
21.2.5.	Voltage References	446
21.2.6.	ADC Timing	447
21.2.7.	Window Detection	450
21.2.8.	ADC Interrupts and DMA	451
21.2.9.	Calibration and Compensation	451
21.3.	ADC Control Register Definitions	452
21.3.1.	ADC Control 0 Register	452
21.3.2.	ADC Control 1 Register	454
21.3.3.	ADC Control 2 Register	454
21.3.4.	ADC Input Select High Register	455
21.3.5.	ADC Input Select Low Register	456
21.3.6.	ADC Offset Calibration Register	459
21.3.7.	ADC Data High Register	460
21.3.8.	ADC Data Low Register	460
21.3.9.	Sample Time Register	461
21.3.10.	ADC Window Upper Threshold High Register	462
21.3.11.	ADC Window Upper Threshold Low Register	463
21.3.12.	ADC Window Lower Threshold High Register	464
21.3.13.	ADC Window Lower Threshold Low Register	465
Chapter 22.	Digital-to-Analog Converter	466
22.1.	Architecture	466
22.2.	Operation	467
22.2.1.	Starting a Conversion	468
22.2.2.	Power Control	469
22.2.3.	Voltage References	469
22.2.4.	DAC Interrupt and DMA	470
22.3.	DAC Control Register Definitions	470
22.3.1.	DAC Control Register	470
22.3.2.	DAC Data High Register	472
22.3.3.	DAC Data Low Register	472
Chapter 23.	Operational Amplifiers	474
23.1.	Architecture	474
23.2.	Operation	476
23.2.1.	Op Amp A	477
23.2.2.	Op Amp B	478
23.3.	Op Amp Register Definitions	480
23.3.1.	Op Amp A Control 0 Register	480



23.3.2.	Op Amp A Control 1 Register	482
23.3.3.	Op Amp B Control 0 Register	483
23.3.4.	Op Amp B Control 1 Register	484
Chapter 24.	Comparators and Reference System	486
24.1.	Architecture	487
24.2.	Comparator Operation	489
24.3.	Reference System Operation	491
24.4.	Comparator and Reference System Register Definitions	493
24.4.1.	Comparator Control Register	494
24.4.2.	Comparator 0 Control 0 Register	495
24.4.3.	Comparator 0 Control 1 Register	496
24.4.4.	Comparator 1 Control 0 Register	497
24.4.5.	Comparator 1 Control 1 Register	498
Chapter 25.	Temperature Sensor	500
25.1.	Operation	500
25.1.1.	Calibration	502
Chapter 26.	Liquid Crystal Display Controller	503
26.1.	Architecture	503
26.2.	Operation	504
26.2.1.	LCD Registers and Subregisters	505
26.2.2.	LCD Display Memory	505
26.2.3.	LCD Frame Timing	507
26.2.4.	LCD Blinking and Blanking	508
26.2.5.	Using the LCD as a Timer	508
26.2.6.	LCD Voltage and Bias Generation	509
26.2.7.	LCD Outputs	510
26.2.8.	Waveform Generation	510
26.2.9.	Contrast Control	518
26.2.10.	Stop Mode Operation	519
26.2.11.	Interrupts	519
26.3.	LCD Control Register Definitions	519
26.3.1.	LCD Subaddress Register	520
26.3.2.	LCD Subdata Register	521
26.3.3.	LCD Clock Register	522
26.3.4.	LCD Control 0 Register	523
26.3.5.	LCD Control 1 Register	524
26.3.6.	LCD Control 2 Register	526
26.3.7.	LCD Control 3 Register	527
26.3.8.	LCD Display Memory Bank A Subregisters	528



26.3.9.	LCD Display Memory Bank B Subregisters	528
Chapter 27.	Flash Memory	529
27.1.	Flash Information Area	531
27.2.	Operation	531
27.2.1.	Flash Operation Timing	533
27.2.2.	Flash Code Protection Against External Access	533
27.2.3.	Flash Code Protection Against Accidental Program and Erasure	533
27.2.4.	Programming	534
27.2.5.	Byte Programming Mode	535
27.2.6.	Word Programming Mode	535
27.2.7.	Page Erase	535
27.2.8.	Mass Erase	536
27.2.9.	Flash Controller Bypass	536
27.2.10.	Flash Controller Behavior in Debug Mode	536
27.3.	Flash Control Register Definitions	537
27.3.1.	Flash Control Register	537
27.3.2.	Flash Status Register	538
27.3.3.	Flash Page Select Register	539
27.3.4.	Flash Block Protect Register	540
27.3.5.	Flash Programming Configuration	541
Chapter 28.	Flash Option Bits	542
28.1.	Operation	542
28.1.1.	Option Bit Configuration by Reset	542
28.1.2.	Option Bit Types	542
28.2.	Flash Option Bit Control Register Definitions	544
28.2.1.	Trim Bit Address Register	545
28.2.2.	Trim Bit Data Register	546
28.3.	Flash Option Bit Address Space	546
28.3.1.	Trim Bit Address Space	548
Chapter 29.	Non-Volatile Data Storage	556
29.1.	Operation	556
29.2.	NVDS Code Interface	556
29.2.1.	Byte Write	556
29.2.2.	Byte Read	557
29.2.3.	Power Failure Protection	558
29.2.4.	Optimizing NVDS Memory Usage for Execution Speed	559



Chapter 30. On-Chip Debugger	560
30.1. Architecture	560
30.2. Operation	561
30.2.1. Development System Overview	561
30.2.2. On-Chip Debugger Interface	562
30.2.3. Debug Mode	563
30.2.4. OCD Data Format	564
30.2.5. OCD Auto-Baud Detector/Generator	564
30.2.6. High-Speed Synchronous Communication	565
30.2.7. OCD Serial Errors	566
30.2.8. Automatic Reset	567
30.2.9. Transmit Flow Control	567
30.2.10. Breakpoints	568
30.2.11. OCD Counter Register	568
30.3. On-Chip Debugger Commands	569
30.4. On-Chip Debugger Control Register Definitions	575
30.4.1. OCD Control Register	575
30.4.2. OCD Status Register	577
30.4.3. Line Control Register	577
30.4.4. Baud Reload Register	578
Chapter 31. eZ8 CPU Instruction Set	580
31.1. Assembly Language Programming Introduction	580
31.2. Assembly Language Syntax	581
31.3. eZ8 CPU Instruction Notation	582
31.4. eZ8 CPU Instruction Classes	583
31.5. eZ8 CPU Instruction Summary	588
Chapter 32. Op Code Maps	597
Chapter 33. Electrical Characteristics	601
33.1. Absolute Maximum Ratings	601
33.2. DC Characteristics	602
33.3. AC Characteristics	604
33.4. On-Chip Peripheral AC and DC Electrical Characteristics	605
33.4.1. Power-On Reset	605
33.4.2. Voltage Brown-Out	606
33.4.3. Stop-Mode Recovery	606
33.4.4. Flash Memory	607
33.4.5. Watchdog Timer	607
33.4.6. Non-Volatile Data Storage	608



33.4.7.	Analog-to-Digital Converter	608
33.4.8.	Digital-to-Analog Converter	612
33.4.9.	Comparator	614
33.4.10.	Reference System	615
33.4.11.	Temperature Sensor	616
33.4.12.	Operational Amplifier	617
33.4.13.	Low Voltage Detect	619
33.4.14.	Liquid Crystal Display	620
33.4.15.	Universal Serial Bus	623
33.4.16.	Internal Precision Oscillator	623
33.4.17.	High Frequency Crystal Oscillator	624
33.4.18.	Low Frequency Crystal Oscillator	625
33.4.19.	Phase-Locked Loop Oscillator	625
33.4.20.	Digitally Controlled Oscillator and Frequency-Locked Loop	626
33.4.21.	General-Purpose I/O Port Input Data Sample Timing	627
33.4.22.	General-Purpose I/O Port Output Timing	628
33.4.23.	On-Chip Debugger Timing	629
33.4.24.	UART Timing	630
Chapter 34.	Packaging	632
Chapter 35.	Ordering Information	633
35.1.	Part Number Listing	633
35.2.	Part Number Suffix Designations	637
35.3.	Precharacterization Product	638
	Index	639
	Customer Support	659

List of Figures

Figure 1.	F6482 Series Block Diagram	4
Figure 2.	Z8F6481, Z8F6081, Z8F3281 and Z8F1681 MCUs, 32-Pin Quad Flat No Lead (QFN) Package 13	
Figure 3.	Z8F6481, Z8F6081, Z8F3281 & Z8F1681 MCUs, 44-Pin Quad Flat No Lead (QFN) and Low-Profile Quad Flat Package (LQFP) 14	
Figure 4.	Z8F6481, Z8F6081 Z8F3281 & Z8F1681 MCUs, 64-Pin Low-Profile Quad Flat Package (LQFP) 15	
Figure 5.	Z8F6482, Z8F6082, Z8F3282 & Z8F1682 MCUs, 64-Pin Low-Profile Quad Flat Package (LQFP) 16	
Figure 6.	Z8F6482, Z8F6082, Z8F3282 & Z8F1682 MCUs, 80-Pin Low-Profile Quad Flat Package (LQFP) 17	
Figure 7.	Power-On Reset Operation	41
Figure 8.	Power-On Reset Behavior	42
Figure 9.	Voltage Brown-Out Reset Operation	43
Figure 10.	GPIO Port Pin Block Diagram	56
Figure 11.	Clock System Block Diagram	98
Figure 12.	Recommended 16MHz Crystal Oscillator Configuration	106
Figure 13.	Recommended 32.768kHz Crystal Oscillator Configuration	107
Figure 14.	FLL Block Diagram	110
Figure 15.	PLL Block Diagram	112
Figure 16.	Interrupt Controller Block Diagram	130
Figure 17.	Timer Block Diagram	150
Figure 18.	Input Path and Noise Filter System Block Diagram	172
Figure 19.	Example with the Timer0 Noise Filter Reassigned to Timer1	173
Figure 20.	Noise Filter Operation	174
Figure 21.	Multi-Channel Timer Block Diagram	188
Figure 22.	Count Modulo Mode	190
Figure 23.	Count Up/Down Mode	190
Figure 24.	Count Up/Down Mode with PWM Channel Outputs and Deadband	194
Figure 25.	Count Max Mode with Channel Compare	195
Figure 26.	Real-Time Clock Block Diagram	210
Figure 27.	UART-LDD Block Diagram	231
Figure 28.	UART-LDD Asynchronous Data Format without Parity	232
Figure 29.	UART-LDD Asynchronous Data Format with Parity	232



Figure 30. UART-LDD Driver Enable Signal Timing with One Stop Bit and Parity 237

Figure 31. UART-LDD Asynchronous Multiprocessor Mode Data Format 238

Figure 32. UART-LDD DALI Standard Frames and Biphase Bit Encoding 244

Figure 33. UART-LDD DMX Frame and Data Slot 248

Figure 34. UART-LDD Receiver Interrupt Service Routine Flow 253

Figure 35. Noise Filter System Block Diagram 255

Figure 36. Noise Filter Operation 257

Figure 37. ESPI Block Diagram 282

Figure 38. ESPI Timing when PHASE=0 286

Figure 39. ESPI Timing when PHASE=1 287

Figure 40. SPI Mode (SSMD=000) 288

Figure 41. I²S Mode (SSMD=010), Multiple Frames 289

Figure 42. ESPI Configured as an SPI Master in a Single Master, Single Slave System .
290

Figure 43. ESPI Configured as an SPI Master in a Single Master, Multiple Slave System
291

Figure 44. ESPI Configured as an SPI Slave 292

Figure 45. I²C Controller Block Diagram 307

Figure 46. Data Transfer Format, Master Write Transaction with a 7-Bit Address .. 313

Figure 47. Data Transfer Format, Master Write Transaction with a 10-Bit Address . 314

Figure 48. Data Transfer Format, Master Read Transaction with a 7-Bit Address .. 316

Figure 49. Data Transfer Format, Master Read Transaction with a 10-Bit Address . 317

Figure 50. Data Transfer Format, Slave Receive Transaction with 7-Bit Address ... 321

Figure 51. Data Transfer Format, Slave Receive Transaction with 10-Bit Address .. 322

Figure 52. Data Transfer Format, Slave Transmit Transaction with 7-bit Address .. 323

Figure 53. Data Transfer Format, Slave Transmit Transaction with 10-Bit Address . 324

Figure 54. USB Block Diagram 340

Figure 55. Example Endpoint Buffer Memory Allocation 344

Figure 56. Control Write Transfer Example 346

Figure 57. Control Read Transfer Example 347

Figure 58. Bulk IN Transfer Example 348

Figure 59. Bulk OUT Transfer Example 350

Figure 60. Direct Memory Access Block Diagram 391

Figure 61. Event System Block Diagram 412

Figure 62. AES Accelerator Block Diagram 425

Figure 63. AES State Array Input and Output 426



Figure 64.	ECB Mode Encryption Flow Diagram	428
Figure 65.	ECB Mode Decryption Flow Diagram	428
Figure 66.	OFB Mode Encryption Flow Diagram	430
Figure 67.	OFB Mode Decryption Flow Diagram	431
Figure 68.	CBC Mode Encryption Flow Diagram	432
Figure 69.	ECB Mode Decryption Flow Diagram for CBC Cipher Text	433
Figure 70.	Analog-to-Digital Converter Block Diagram	440
Figure 71.	ADC Data (12-Bit) vs. Input Voltage for Single-Ended Input Modes	443
Figure 72.	ADC Data (12-Bit) vs. Input Voltage for Balanced Differential Input Mode	443
Figure 73.	ADC Data (12-Bit) vs. Input Voltage for Unbalanced Differential Input Mode	444
Figure 74.	ADC Timing Diagram for 12-Bit Resolution	448
Figure 75.	ADC Timing Diagram for 2-Pass 14-Bit Resolution with INMODE=10, 11	449
Figure 76.	ADC Timing Diagram for 2-Pass 14-Bit Resolution with INMODE=01	449
Figure 77.	ADC Input Equivalent Circuit	450
Figure 78.	Digital-to-Analog Converter Block Diagram	467
Figure 79.	Output Voltage vs. DAC Data	468
Figure 80.	Op Amp A Block Diagram	475
Figure 81.	Op Amp B Block Diagram	476
Figure 82.	Op Amp B Connections for Current Sourcing/Sinking	479
Figure 83.	Comparators Block Diagram	487
Figure 84.	Reference System Block Diagram	488
Figure 85.	Liquid Crystal Display Controller Block Diagram	504
Figure 86.	LCD Voltage and Bias Generation Block Diagram	509
Figure 87.	Static Mode Example Waveforms	512
Figure 88.	1/2 Duty Mode with 1/2 Bias Type A Example Waveforms	513
Figure 89.	1/2 Duty Mode with 1/2 Bias Type B Example Waveforms	514
Figure 90.	1/3 Duty Mode with 1/3 Bias Type A Example Waveforms	515
Figure 91.	1/3 Duty Mode with 1/3 Bias Type B Example Waveforms	516
Figure 92.	1/4 Duty Mode with 1/3 Bias Type A Example Waveforms	517
Figure 93.	1/4 Duty Mode with 1/3 Bias Type B Example Waveforms	518
Figure 94.	Flash Memory Arrangement	530
Figure 95.	Flash Controller Operation Flowchart	532
Figure 96.	On-Chip Debugger Block Diagram	560



Figure 97. Development System	561
Figure 98. Target OCD Connector Interface	562
Figure 99. Interfacing the On-Chip Debugger's DBG Pin with an RS-232 Interface, #1 of 2	562
Figure 100. Interfacing the On-Chip Debugger's DBG Pin with an RS-232 Interface, #2 of 2	563
Figure 101. OCD Data Format	564
Figure 102. Synchronous Operation	566
Figure 103. Start Bit Flow Control	567
Figure 104. Op Code Map Cell Description	597
Figure 105. First Op Code Map	599
Figure 106. Second Op Code Map after 1Fh	600
Figure 107. Maximum System Clock Frequency vs. V_{DD}	605
Figure 108. Port Input Sample Timing	627
Figure 109. GPIO Port Output Timing	628
Figure 110. On-Chip Debugger Timing	629
Figure 111. UART Timing With CTS	630
Figure 112. UART Timing Without CTS	631



List of Tables

Table 1.	F6482 Series Family Part Selection Guide	3
Table 2.	Acronyms and Expansions	9
Table 3.	F6482 Series Package Options	12
Table 4.	Signal Descriptions	18
Table 5.	Pin Characteristics	22
Table 6.	F6482 Series Program Memory Maps	25
Table 7.	F6482 Series Flash Memory Information Area Map	26
Table 8.	Register File Address Map	27
Table 9.	Reset, Stop-Mode Recovery Characteristics and Latency	39
Table 10.	System Reset Sources and Resulting Reset Type	40
Table 11.	Stop-Mode Recovery Sources and Resulting Action	46
Table 12.	Reset Status Register (RSTSTAT)	48
Table 13.	Reset Status Per Event	49
Table 14.	Power Control Register 0 (PWRCTL0)	52
Table 15.	Power Control Register 1 (PWRCTL1)	54
Table 16.	Port Availability by Device and Package Type	55
Table 17.	Port Alternate Function Mapping, 32-Pin Parts	58
Table 18.	Port Alternate Function Mapping (44-Pin Parts)	62
Table 19.	Port Alternate Function Mapping (Z8Fxx81 64-Pin Parts)	66
Table 20.	Port Alternate Function Mapping (Z8Fxx82 64-Pin Parts)	72
Table 21.	Port Alternate Function Mapping, 80-Pin Parts	78
Table 22.	GPIO Port Registers and Subregisters	85
Table 23.	Port A–J GPIO Address Registers (PxADDR)	86
Table 24.	Port A–J Control Registers (PxCTL)	87
Table 25.	Port A–J Data Direction Subregisters (PxDD)	87
Table 26.	Port A–J Alternate Function Subregisters (PxAF)	88
Table 27.	Port A–J Output Control Subregisters (PxOC)	89
Table 28.	Port A–J High Drive Enable Subregisters (PxHDE)	89
Table 29.	Port A–G Stop-Mode Recovery Source Enable Subregisters (PxSMRE)	90
Table 30.	Port A–J Pull-Up Enable Subregisters (PxPUE)	91
Table 31.	Port A–G Alternate Function Set 1 Subregisters (PxAFS1)	92
Table 32.	Port C Alternate Function Set 2 Subregisters (PxAFS2)	93
Table 33.	Port A–J Input Data Registers (PxIN)	94



Table 34.	Port A–J Output Data Register (PxOUT)	95
Table 35.	System Clock Configuration and Selection	99
Table 36.	Peripheral Clock Sources and Usage	101
Table 37.	Common PLL Configurations for 48MHz PLLCLK	113
Table 38.	Clock Control 0 Register (CLKCTL0)	115
Table 39.	Clock Control 1 Register (CLKCTL1)	116
Table 40.	Clock Control 2 Register (CLKCTL2)	117
Table 41.	Clock Control 4 Register (CLKCTL4)	119
Table 42.	Clock Control 3 Register (CLKCTL3)	119
Table 43.	Clock Control 5 Register (CLKCTL5)	120
Table 44.	Clock Control 6 Register (CLKCTL6)	121
Table 45.	Clock Control 7 Register (CLKCTL7)	122
Table 46.	Clock Control 8 Register (CLKCTL8)	122
Table 47.	Clock Control 9 Register (CLKCTL9)	123
Table 48.	Clock Control A Register (CLKCTLA)	123
Table 49.	Clock Control B Register (CLKCTLB)	125
Table 50.	Clock Control C Register (CLKCTLC)	126
Table 51.	Trap and Interrupt Vectors in Order of Priority	128
Table 52.	Interrupt Request 0 Register (IRQ0)	133
Table 53.	Interrupt Request 1 Register (IRQ1)	134
Table 54.	Interrupt Request 2 Register (IRQ2)	135
Table 55.	Interrupt Request 3 Register (IRQ3)	136
Table 56.	IRQ0 Enable and Priority Encoding	137
Table 57.	IRQ0 Enable High Bit Register (IRQ0ENH)	137
Table 58.	IRQ0 Enable Low Bit Register (IRQ0ENL)	138
Table 59.	IRQ1 Enable and Priority Encoding	139
Table 60.	IRQ1 Enable High Bit Register (IRQ1ENH)	139
Table 61.	IRQ1 Enable Low Bit Register (IRQ1ENL)	140
Table 62.	IRQ2 Enable and Priority Encoding	140
Table 63.	IRQ2 Enable High Bit Register (IRQ2ENH)	141
Table 64.	IRQ2 Enable Low Bit Register (IRQ2ENL)	141
Table 65.	IRQ3 Enable and Priority Encoding	142
Table 66.	IRQ3 Enable High Bit Register (IRQ3ENH)	142
Table 67.	IRQ3 Enable Low Bit Register (IRQ3ENL)	144
Table 68.	Interrupt Edge Select Register (IRQES)	145
Table 69.	Shared Interrupt Select Register 0 (IRQSS0)	146



Table 70.	Shared Interrupt Select Register 1 (IRQSS1)	147
Table 71.	Interrupt Control Register (IRQCTL)	148
Table 72.	Timer Operating Modes	152
Table 73.	Triggered One-Shot Mode Initialization Example	154
Table 74.	Demodulation Mode Initialization Example.	169
Table 75.	Timer 0–2 High Byte Registers (TxH)	175
Table 76.	Timer 0–2 Low Byte Registers (TxL)	175
Table 77.	Timer 0–2 Reload High Byte Registers (TxRH)	176
Table 78.	Timer 0–2 Reload Low Byte Registers (TxRL)	176
Table 79.	Timer 0–2 PWM0 High Byte Registers (TxPWM0H)	177
Table 80.	Timer 0–2 PWM0 Low Byte Registers (TxPWM0L)	177
Table 81.	Timer 0–2 PWM1 High Byte Registers (TxPWM1H)	178
Table 82.	Timer 0–2 PWM1 Low Byte Registers (TxPWM1L)	178
Table 83.	Timer 0–2 Control 0 Registers (TxCTL0)	179
Table 84.	Timer 0–2 Control 1 Registers (TxCTL1)	180
Table 85.	Timer 0–2 Control 2 Registers (TxCTL2)	184
Table 86.	Timer 0–2 Status Register (TxSTAT)	185
Table 87.	Timer 0–2 Noise Filter Control Registers (TxNFC)	186
Table 88.	Timer Count Modes	189
Table 89.	Multi-Channel Timer Address Map	195
Table 90.	MCT High Byte Register (MCTH)	197
Table 91.	MCT Low Byte Register (MCTL)	197
Table 92.	MCT Reload High Byte Register (MCTRH)	198
Table 93.	MCT Reload Low Byte Register (MCTRL)	198
Table 94.	MCT Subaddress Register (MCTSA)	198
Table 95.	MCT Subregister x (MCTSRx)	199
Table 96.	Multi-Channel Timer Control 0 Register (MCTCTL0)	199
Table 97.	Multi-Channel Timer Control 1 Register (MCTCTL1)	201
Table 98.	Multi-Channel Timer Channel Status 0 Register (MCTCHS0)	202
Table 99.	Multi-Channel Timer Channel Status 1 Register (MCTCHS1)	202
Table 100.	Multi-Channel Timer Channel Control Register (MCTCHyCTL)	203
Table 101.	Multi-Channel Timer Channel-y High Byte Registers (MCTCHyH)	205
Table 102.	Multi-Channel Timer Channel-y Low Byte Registers (MCTCHyL)	205
Table 103.	Watchdog Timer Approximate Time-Out Delays	206
Table 104.	Watchdog Timer Reload Low Byte Register (WDTL=FF3h)	209
Table 105.	Watchdog Timer Reload High Byte Register (WDTH=FF2h)	209



Table 106.	Real-Time Clock Seconds Register (RTC_SEC)	213
Table 107.	Real-Time Clock Minutes Register (RTC_MIN)	214
Table 108.	Real-Time Clock Hours Register (RTC_HRS)	216
Table 109.	Real-Time Clock Day-of-the-Month Register (RTC_DOM)	217
Table 110.	Real-Time Clock Day-of-the-Week Register (RTC_DOW)	218
Table 111.	Real-Time Clock Month Register (RTC_MON)	219
Table 112.	Real-Time Clock Year Register (RTC_YR)	220
Table 113.	Real-Time Clock Alarm Seconds Register (RTC_ASEC)	221
Table 114.	Real-Time Clock Alarm Minutes Register (RTC_AMIN)	222
Table 115.	Real-Time Clock Alarm Hours Register (RTC_AHRS)	223
Table 116.	Real-Time Clock Alarm Day-of-the-Month Register (RTC_ADOM)	224
Table 117.	Real-Time Clock Alarm Day-of-the-Week Register (RTC_ADOW)	225
Table 118.	Real-Time Clock Alarm Control Register (RTC_ACTRL)	226
Table 119.	Real-Time Clock Timing Register (RTC_TIM)	228
Table 120.	Real-Time Clock Control Register (RTC_CTRL)	229
Table 121.	UART-LDD 0–1 Transmit Data Registers (UxTXD)	258
Table 122.	UART-LDD 0–1 Receive Data Registers (UxRXD)	258
Table 123.	UART-LDD 0–1 Status 0 Registers, Standard UART Mode (UxSTAT0)	259
Table 124.	UART-LDD 0–1 Status 0 Registers, LIN Mode (UxSTAT0)	260
Table 125.	UART-LDD 0–1 Status 0 Registers, DALI Mode (UxSTAT0)	262
Table 126.	UART-LDD 0–1 Status 0 Registers, DMX Mode (UxSTAT0)	263
Table 127.	UART-LDD 0–1 Mode Select and Status Registers (UxMDSTAT)	264
Table 128.	Mode Status Fields	265
Table 129.	UART-LDD 0–1 Control 0 Registers (UxCTL0)	267
Table 130.	Multiprocessor Control 0–1 Registers (UxCTL1 with MSEL=000b)	269
Table 131.	Noise Filter Control 0–1 Registers (UxCTL1 with MSEL=001b)	271
Table 132.	LIN Control 0–1 Registers (UxCTL1 with MSEL=010b)	272
Table 133.	DALI Control 0–1 Registers (UxCTL1 with MSEL=100b)	273
Table 134.	DMX Control 0–1 Registers (UxCTL1 with MSEL=101b)	274
Table 135.	UART-LDD 0–1 Address Compare Registers (UxADDR)	276
Table 136.	UART-LDD 0–1 Baud Rate High Byte Registers (UxBRH)	276
Table 137.	UART-LDD 0–1 Baud Rate Low Byte Registers (UxBRL)	277
Table 138.	UART-LDD Baud Rates, 20.0MHz System Clock	278
Table 139.	UART-LDD Baud Rates, 19.99848MHz System Clock	279
Table 140.	UART-LDD Baud Rates, 10.0 MHz System Clock	279
Table 141.	UART-LDD Baud Rates, 7.3728MHz System Clock	279



Table 142. UART-LDD Baud Rates, 2.4576MHz System Clock	280
Table 143. ESPI Clock Phase (PHASE) and Clock Polarity (CLKPOL) Operation . .	285
Table 144. ESPI 0-1 Data Registers (ESPIxDATA)	296
Table 145. ESPI 0-1 Transmit Data Command Registers (ESPIxTDCR)	296
Table 146. ESPI 0-1 Control Registers (ESPIxCTL)	297
Table 147. ESPI 0-1 Mode Registers (ESPIxMODE)	299
Table 148. ESPI 0-1 Status Registers (ESPIxSTAT)	301
Table 149. ESPI S0-1 State Registers (ESPIxSTATE)	302
Table 150. ESPISTATE Values	303
Table 151. ESPI 0-1 Baud Rate High Byte Registers (ESPIxBRH)	304
Table 152. ESPI 0-1 Baud Rate Low Byte Registers (ESPIxBRL)	305
Table 153. I ² C Master/Slave Controller Registers	307
Table 154. I ² C Data Register (I2CDATA=F50h)	329
Table 155. I ² C Interrupt Status Register (I2CISTAT=F51h)	330
Table 156. I ² C Control Register (I2CCTL)	331
Table 157. I ² C Baud Rate High Byte Register (I2CBRH=53h)	333
Table 158. I ² C Baud Rate Low Byte Register (I2CBRL=F54h)	333
Table 159. I ² C State Register (I2CSTATE), Description when DIAG=1	334
Table 160. I ² C State Register (I2CSTATE), Description when DIAG=0	335
Table 161. I2CSTATE_H	336
Table 162. I2CSTATE_L	336
Table 163. I ² C Mode Register (I ² C Mode=F56h)	337
Table 164. I ² C Slave Address Register (I2CSLVAD=57h)	339
Table 165. Determining USB Endpoint Buffer Memory Allocation with All Endpoints Used 342	
Table 166. Determining USB Endpoint Buffer Memory Allocation with Only Endpoints 0, 1 and 2 Used 343	
Table 167. USB Module Response to Host upon Receiving an IN Token	349
Table 168. USB Module Response to Host upon Receiving an OUT Token	350
Table 169. USB Registers and Subregisters	356
Table 170. USB Subaddress Register (USBSA)	358
Table 171. USB Subdata Register (USBSD)	359
Table 172. USB Control Register (USBCTL)	360
Table 173. USB DMA 0–1 Control Registers (USBDMAxCTL)	361
Table 174. USB DMA Data Register (USBDMADATA)	362
Table 175. USB Interrupt Control Register (USBIRQCTL)	363



Table 176.	USB OUT Endpoint 1–3 Start Address Subregisters (USBOxADDR) . . .	364
Table 177.	USB IN Endpoints Start Address Subregister (USBISTADDR)	365
Table 178.	USB IN Endpoint 1–3 Start Address Subregisters (USBIXADDR)	366
Table 179.	USB Clock Gate Subregister (USBCLKGATE)	367
Table 180.	USB Interrupt Identification Subregister (USBIID)	368
Table 181.	USB IN Interrupt Request Subregister (USBINIRQ)	369
Table 182.	USB OUT Interrupt Request Subregister (USBOUTIRQ)	370
Table 183.	USB Protocol Interrupt Request Subregister (USBIRQ)	371
Table 184.	USB IN Interrupt Enable Subregister (USBINIEN)	372
Table 185.	USB OUT Interrupt Enable Subregister (USBOUTIEN)	373
Table 186.	USB Protocol Interrupt Enable Subregister (USBIEN)	374
Table 187.	USB Endpoint 0 Control and Status Subregister (USBEP0CS)	375
Table 188.	USB IN 0–3 Byte Count Subregisters (USBIXBC)	376
Table 189.	USB Subaddress Subregister (USBIXCS)	377
Table 190.	USB OUT 0–3 Byte Count Subregisters (USBOxBC)	378
Table 191.	USB OUT 1–3 Control and Status Subregisters (USBOxCS)	379
Table 192.	USB Control and Status Subregister (USBCS)	380
Table 193.	USB Toggle Control Subregister (USBTOGCTL)	381
Table 194.	USB Frame Count Low Subregister (USBFCL)	382
Table 195.	USB Function Address Subregister (USBFNADDR)	384
Table 196.	USB Frame Count High Subregister (USBFCH)	384
Table 197.	USB Endpoint Pairing Subregister (USBPAIR)	385
Table 198.	USB IN Endpoint Valid Subregister (USBINVAL)	386
Table 199.	USB OUT Endpoint Valid Subregister (USBOUTVAL)	387
Table 200.	USB IN Endpoints Stop Address Subregister (USBISPADDR)	388
Table 201.	USB Setup Buffer Byte 0–7 Subregisters (USBSUx)	389
Table 202.	DMA Descriptors	396
Table 203.	DMA Registers and Subregisters	399
Table 204.	DMA 0–3 Subaddress/Status Register (DMAxSA)	400
Table 205.	DMA 0–3 Subdata Register (DMAxSD)	401
Table 206.	DMA Global Control Register (DMACTL)	402
Table 207.	DMA Source Address High Subregister (DMAxSRCH)	403
Table 208.	DMA Destination Address High Subregister (DMAxDSTH)	404
Table 209.	DMA Source Address Low Subregister (DMAxSRCL)	404
Table 210.	DMA Destination Address Low Subregister (DMAxDSTL)	405
Table 211.	DMA Count Subregister High (DMAxCNTH)	406



Table 212.	DMA Count Subregister Low (DMAxCNTL)	407
Table 213.	DMA 0–3 Control 0 Subregisters (DMAxCTL0).	407
Table 214.	DMA 0–3 Control 1 Subregisters (DMAxCTL1).	408
Table 215.	DMA 0–3 Linked List Descriptor Address High Subregister (DMAxLAH)	410
Table 216.	DMA 0–3 Linked List Descriptor Address Low Subregister (DMAxLAL)	410
Table 217.	Event System Signal Sources	413
Table 218.	Event System Destinations	414
Table 219.	Event System Registers and Subregisters	417
Table 220.	Event System Source Subaddress Register (ESSSA).	418
Table 221.	Event System Source Subdata Register (ESSSD)	419
Table 222.	Event System Channel 0–7 Source Subregisters (ESCHxSRC).	420
Table 223.	Event System Destination Subaddress Register (ESDSA).	421
Table 224.	Event System Destination Subdata Register (ESDSD)	422
Table 225.	Event System Destination 0–3F Channel Subregisters (ESDSTxCH).	423
Table 226.	Register Bit Settings for Auto-Start	426
Table 227.	Register Bit Settings for DMA Support, AUTODIS=0.	427
Table 228.	AES Register Summary	435
Table 229.	AES Data Register (AESDATA)	435
Table 230.	AES Initialization Vector Register (AESIV)	436
Table 231.	AES Key Register (AESKEY)	436
Table 232.	AES Control Register (AESCTL).	437
Table 233.	AES Status Register (AESSTAT).	438
Table 234.	Input Mode Summary	441
Table 235.	Compensating ADC results for ADC offset	452
Table 236.	ADC Control 0 Register (ADCCTL0)	452
Table 237.	ADC Control 1 Register (ADCCTL1)	454
Table 238.	ADC Control 2 Register (ADCCTL2)	455
Table 239.	ADC Input Select High Register (ADCINSH).	456
Table 240.	ADC Input Select Low Register (ADCINSL)	456
Table 241.	ADC Offset Calibration Register (ADCOFF)	459
Table 242.	ADC Data High Register (ADCD_H)	460
Table 243.	ADC Data Low Register (ADCD_L).	460
Table 244.	Sample Time (ADCST)	461
Table 245.	ADC Window Upper Threshold High Register (ADCUWINH)	462



Table 246.	ADC Window Upper Threshold Low Register (ADCUWINL)	463
Table 247.	ADC Window Lower Threshold High Register (ADCLWINH)	464
Table 248.	ADC Window Lower Threshold Low Register (ADCLWINL)	465
Table 249.	DAC Control Register (DACCTL)	470
Table 250.	DAC Data High Register (DACD_H)	472
Table 251.	DAC Data Low Register (DACD_L)	472
Table 252.	Op Amp Register Summary	480
Table 253.	Op Amp A Control 0 Register (AMPACTL0)	481
Table 254.	Op Amp A Control 1 Register (AMPACTL1)	482
Table 255.	Op Amp B Control 0 Register (AMPBCTL0)	483
Table 256.	Op Amp B Control 1 Register (AMPBCTL1)	484
Table 257.	Effect of WINEN and POLSEL on Comparator Outputs	490
Table 258.	Comparator Control Register (CMPCTL)	494
Table 259.	Comparator 0 Control 0 Register (CMP0CTL0)	495
Table 260.	Comparator 0 Control 1 Register (CMP0CTL1)	496
Table 261.	Comparator 1 Control 0 Register (CMP1CTL0)	497
Table 262.	Comparator 1 Control 1 Register (CMP1CTL1)	498
Table 263.	Temperature vs. ADC Output, ADC VREF = 1.25 V	501
Table 264.	LCD Display Memory Organization	506
Table 265.	V _{LCD} and Bias Generator Source Selection	510
Table 266.	LCD Mode Selection and Corresponding Waveform Characteristics	511
Table 267.	LCD Controller Registers and Subregisters	519
Table 268.	LCD Subaddress Register (LCDSA)	520
Table 269.	LCD Subdata Register (LCDS)	521
Table 270.	LCD Clock Register (LCDCLK)	522
Table 271.	LCD Control 0 Register (LCDCTL0)	523
Table 272.	LCD Control 1 Register (LCDCTL1)	524
Table 273.	LCD Control 2 Register (LCDCTL2)	526
Table 274.	LCD Control 3 Register (LCDCTL3)	527
Table 275.	LCD Display Memory Bank A Subregisters (LCDMEMAx)	528
Table 276.	LCD Display Memory Bank B Subregisters (LCDMEMBx)	528
Table 277.	F6482 Series Flash Memory Configurations	529
Table 278.	Flash Code Protection Using the Flash Option Bit	533
Table 279.	Flash Control Register (FCTL)	538
Table 280.	Flash Status Register (FSTAT)	538
Table 281.	Flash Page Select Register (FPS)	539



Table 282. Flash Block Protect Register (FBP)	540
Table 283. Flash Programming Configuration Register (FPCONFIG)	541
Table 284. Trim Bit Address Register (TRMADR)	545
Table 285. Trim Bit Address Map	545
Table 286. Trim Bit Data Register (TRMDR)	546
Table 287. Flash Option Bits at Program Memory Address 0000h	546
Table 288. Flash Option Bits at Program Memory Address 0001h	547
Table 289. Trim Bit Address Description.	548
Table 290. Trim Option Bits at Address 0000h (TBA0)	548
Table 291. Trim Option Bits at Address 0001h (TTEMP0)	549
Table 292. Trim Option Bits at Address 0002h (TTEMP1)	549
Table 293. Trim Option Bits at Address 0003h (TIPO)	550
Table 294. Trim Option Bits at Address 0004h (TLVD_VBO)	550
Table 295. LVD_Trim Values	551
Table 296. Trim Option Bits at Address 0005h (TVREF)	552
Table 297. Trim Option Bits at Address 0006h (TVBGVREG)	552
Table 298. Trim Option Bits at Address 0007h (TWDT)	553
Table 299. Trim Option Bits at Address 0008h (TLCD0)	553
Table 300. Trim Option Bits at Address 0009h (TLCD1)	554
Table 301. Trim Option Bits at Address 000Ah	554
Table 302. Trim Option Bits at Address 000Bh	555
Table 303. Trim Option Bits at Address 000Ch (TVBIAS)	555
Table 304. Write Status Byte	557
Table 305. Read Status Byte	558
Table 306. NVDS Access Latency	559
Table 307. OCD Baud-Rate Limits	565
Table 308. On-Chip Debugger Commands	570
Table 309. OCD Control Register (OCDCTL)	575
Table 310. OCD Status Register (OCDSTAT)	577
Table 311. OCD Line Control Register (OCDLCR)	577
Table 312. Baud Reload Register	578
Table 313. Assembly Language Source Program Example	580
Table 314. Assembly Language Syntax Example 1	581
Table 315. Assembly Language Syntax Example 2	581
Table 316. Notational Shorthand	582
Table 317. Additional Symbols	583



Table 318. Arithmetic Instructions	584
Table 319. Bit Manipulation Instructions	585
Table 320. Block Transfer Instructions	585
Table 321. CPU Control Instructions	585
Table 322. Logical Instructions	586
Table 323. Load Instructions	586
Table 324. Program Control Instructions	587
Table 325. Rotate and Shift Instructions.	587
Table 326. eZ8 CPU Instruction Summary.	588
Table 327. Op Code Map Abbreviations	598
Table 328. Absolute Maximum Ratings*	601
Table 329. DC Characteristics	602
Table 330. Supply Current Characteristics	603
Table 331. AC Characteristics	604
Table 332. Power-On Reset Electrical Characteristics and Timing	605
Table 333. Voltage Brown-Out Electrical Characteristics and Timing	606
Table 334. Stop-Mode Recovery (SMR) Timing	606
Table 335. Flash Memory Electrical Characteristics and Timing	607
Table 336. Watchdog Timer Electrical Characteristics and Timing.	607
Table 337. Non-Volatile Data Storage Electrical Characteristics and Timing	608
Table 338. Analog-to-Digital Converter Electrical Characteristics and Timing	608
Table 339. Digital-to-Analog Converter Electrical Characteristics and Timing	612
Table 340. Comparator Electrical Characteristics	614
Table 341. Reference System Electrical Characteristics	615
Table 342. Temperature Sensor Electrical Characteristics	616
Table 343. Operational Amplifier Electrical Characteristics	617
Table 344. Low Voltage Detect Electrical Characteristics	619
Table 345. LCD Electrical Characteristics	620
Table 346. USB Electrical Characteristics	623
Table 347. IPO Electrical Characteristics.	623
Table 348. High Frequency Crystal Oscillator (HFXO) Characteristics	624
Table 349. Low Frequency Oscillator (LFXO) Characteristics	625
Table 350. PLL Electrical Characteristics	625
Table 351. DCO and FLL Electrical Characteristics	626
Table 352. GPIO Port Input Timing	627
Table 353. GPIO Port Output Timing.	628



Table 354. On-Chip Debugger Timing.....	629
Table 355. UART Timing with CTS	630
Table 356. UART Timing Without CTS	631
Table 357. F6482 Series Ordering Information	633
Table 358. ZMOTION Library Series Ordering Information.....	636
Table 359. Package and Pin Count Description	638

Chapter 1. Overview

Zilog's F6482 Series MCUs, members of the Z8 Encore! XP[®] family, are based on Zilog's advanced 8-bit eZ8 CPU core. This microcontroller is optimized for low-power and wireless applications, and supports 1.8V to 3.6V low-voltage operation with extremely low Active, Halt and Stop Mode currents, plus it offers an assortment of speed and low-power options. In addition, the feature-rich analog and digital peripherals of the F6482 Series makes it suitable for a variety of applications including safety and security, utility metering, digital power supervisory, hand-held electronic devices, and general motor control.

1.1. Features

Key features of the F6482 Series MCU include:

- 24MHz eZ8 CPU core
- 16KB, 32KB, 60KB or 64KB Flash memory with in-circuit programming capability
- 2KB or 3.75KB internal RAM
- 128B Non-Volatile Data Storage (NVDS)
- Up to 17-Channel, 12-bit Analog-to-Digital Converter (ADC) that can be configured for internal or external voltage reference and single-ended or differential inputs
- 12-bit Digital-to-Analog Converter (DAC)
- Integrated LCD driver with blinking and contrast control for up to 96 segments
- 128-bit Advanced Encryption Standard (AES) encryption/decryption hardware accelerator according to FIPS PUB 197
- Real-Time Clock (RTC) supporting both Counter and Clock modes
- On-Chip Temperature Sensor
- Two on-chip analog comparators (32-pin and 64-pin with LCD packages contain only one)
- Two on-chip, low-power operational amplifiers (32-pin and 64-pin with LCD packages contain only one)
- 8 Channel Event System provides communication between peripherals for autonomous triggering
- Full-Speed Universal Serial Bus (USB 2.0) device supporting eight endpoints with integrated USB-PHY (not available on 64-pin package with LCD)

- Two full-duplex 9-bit UART ports with the support of Local Interconnect Network (LIN) and Digital Addressable Lighting Interface (DALI) protocols (32-pin and 64-pin with LCD packages contain only one)
- RS-485 Multidrop Mode up to 250kbit/sec (DMX Support) integrated with UARTs
- Two Enhanced Serial Peripheral Interface (SPI) controllers (32-pin and 44-pin packages contain only one)
- I²C controller which supports Master/Slave modes
- Four-channel DMA controller
- Three enhanced 16-bit timers with Capture, Compare, and PWM capability
- Two additional basic 16-bit timers with interrupt (shared as UART Baud Rate Generator)
- 16-bit Multi-Channel Timer which supports four Capture/Compare/PWM modules (not available on 32-pin and 64-pin with LCD packages)
- Watchdog Timer (WDT)
- 26 to 67 General-Purpose Input/Output (GPIO) pins, depending upon package
- Up to 41 interrupt sources with up to 30 interrupt vectors
- On-Chip Debugger (OCD)
- Power-On Reset (POR) and Voltage Brown-Out (VBO) protection
- Built-in Low-Voltage Detection (LVD) with programmable voltage threshold
- Low Frequency Crystal Oscillator (LFXO) operating at 32.768kHz with low power consumption
- Internal clock sources and clock multiplication including: Internal Precision Oscillator (IPO), Digitally Controlled Oscillator (DCO), Watchdog Timer Oscillator (WTO), Frequency Locked Loop (FLL) and Phase Locked Loop (PLL)
- High Frequency Crystal Oscillator (HFXO) operating in the 1–24MHz range
- Wide operation voltage range: 1.8V–3.6V
- 32-, 44-, 64-, and 80-pin packages
- –40°C to +85°C (extended) operating temperature range

1.2. Part Selection Guide

Table 1 shows basic features and package styles available for each device within the F6482 Series product line.



Table 1. F6482 Series Family Part Selection Guide

Part Number	Flash (KB)	RAM (B)	LCD	NVDS (B)	I/O	ADC Inputs	SPI	I ² C	UARTs	USB	Packages
Z8F6482	64	3840	Yes	–	26–67	8–12	2	1	1–2	0–1	64- and 80-pin
Z8F6082	60	3840	Yes	128	26–67	8–12	2	1	1–2	0–1	64- and 80-pin
Z8F3282	32	3840	Yes	128	26–67	8–12	2	1	1–2	0–1	64- and 80-pin
Z8F1682	16	2048	Yes	128	26–67	8–12	2	1	1–2	0–1	64- and 80-pin
Z8F6481	64	3840	No	–	26–67	9–12	1–2	1	1–2	1	32-, 44- and 64-pin
Z8F6081	60	3840	No	128	26–67	9–12	1–2	1	1–2	1	32-, 44- and 64-pin
Z8F3281	32	3840	No	128	26–67	9–12	1–2	1	1–2	1	32-, 44- and 64-pin
Z8F1681	16	2048	No	128	26–67	9–12	1–2	1	1–2	1	32-, 44- and 64-pin

1.3. Block Diagram

Figure 1 shows a block diagram of the F6482 Series architecture.

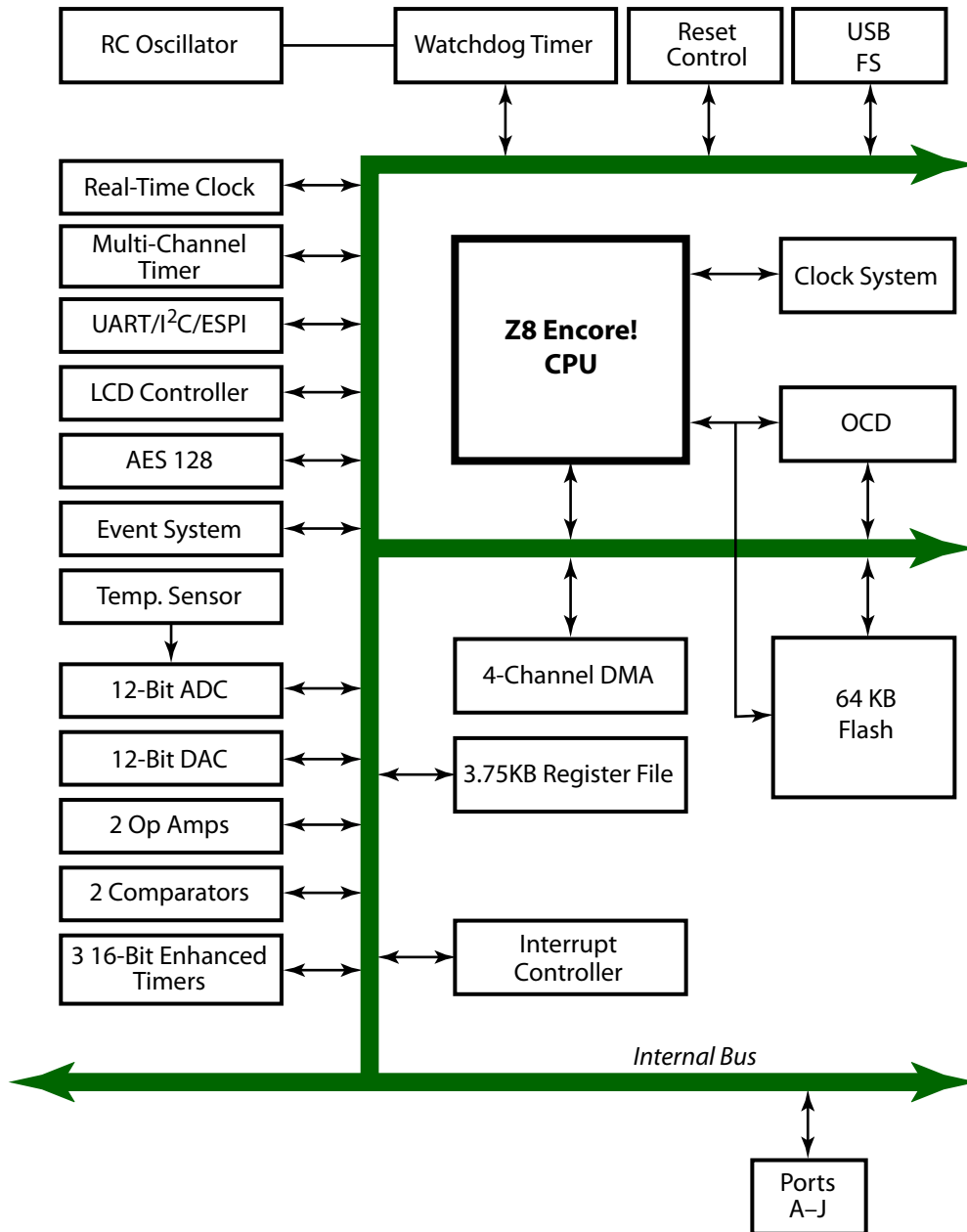

Figure 1. F6482 Series Block Diagram

1.4. eZ8 CPU and Peripheral Overview

Zilog's 8-bit eZ8 CPU meets the continuing demand for faster and more code-efficient microcontrollers. It executes a superset of the original Z8 instruction set. The key features of the eZ8 CPU are:

- Direct register-to-register architecture allows each register to function as an accumulator, improving execution time and decreasing the required Program Memory
- Software stack allows greater depth in subroutine calls and interrupts more than hardware stacks
- Compatible with existing Z8 code
- Expanded internal Register File allows access up to 4KB
- New instructions improve execution efficiency for code developed using higher-level programming languages including C
- Pipelined instruction fetch and execution
- New instructions for improved performance including BIT, BSWAP, BTJ, CPC, LDC, LDCI, LEA, MULT and SRL
- New instructions support 12-bit linear addressing of the register file
- Up to 12MIPS operation
- C Compiler-friendly
- 2 to 9 clock cycles per instruction

To learn more about the eZ8 CPU, refer to the [eZ8 CPU Core User Manual \(UM0128\)](#), which is available free for download from the Zilog website.

1.4.1. General-Purpose Input/Output

The F6482 Series features 26 to 67 port pins (Ports A–J) for general purpose input/output (GPIO). The number of GPIO pins available is a function of package. Each pin is individually programmable.

1.4.2. Flash Controller

The Flash Controller is used to program and erase Flash memory, and supports protection against accidental program and erasure.

1.4.3. Non-Volatile Data Storage

The Non-Volatile Data Storage (NVDS) uses a hybrid hardware/software scheme to implement a byte-programmable data memory and is capable of over 100,000 write cycles.

1.4.4. Clock System

The clock system generates a System Clock, a low-frequency Peripheral Clock, and the Watchdog Timer Oscillator. It is comprised of:

- Watchdog Timer Oscillator (WTO).
- 32.768kHz Internal Precision Oscillator (IPO).
- Low Frequency Crystal Oscillator (LFXO) which is a low-power oscillator optimized for use with a 32.768kHz watch crystal. The IPO and LFXO can be used as clock sources for the Real-Time Clock (RTC), Liquid Crystal Display (LCD) and Timers in any mode, and as the reference clock for the Frequency Locked Loop (FLL).
- High Frequency Crystal Oscillator (HFXO) that provides highly accurate clock frequencies using an external crystal or ceramic resonator.
- Phase Locked Loop (PLL) which is clocked by the HFXO and can be selected as a system clock and/or as the USB clock.
- Digitally Controlled Oscillator (DCO).
- Frequency Locked Loop (FLL). The reference clock for the FLL can be either an Internal Precision Oscillator (IPO) or a Low Frequency Crystal Oscillator. The FLL, in conjunction with the DCO can be configured to generate system clock frequencies from 1 to 24MHz.

1.4.5. 12-Bit Analog-to-Digital Converter

The Analog-to-Digital Converter (ADC) converts an analog input signal to a 12-bit binary number. The ADC supports up to eight analog input sources multiplexed with GPIO ports. It is configurable for internal or external voltage reference and single-ended or differential inputs.

1.4.6. 12-Bit Digital-to-Analog Converter

The Digital-to-Analog Converter (DAC) converts a 12-bit digital code to an analog output voltage. The DAC supports both internal and external references.

1.4.7. Low-Power Operational Amplifiers

Two low-power operational amplifiers (Op Amps) are provided: Op Amp A and Op Amp B. Op Amp A is a low-power, general-purpose operational amplifier with optional internal programmable gain settings. Op Amp B is a low-power, general-purpose operational amplifier that can optionally be internally configured as a current source/sink. Each Op Amp output can be internally routed to the ADC, a comparator, or an output pin. These op amps can function in all operating modes, including Stop Mode.

1.4.8. Analog Comparators

The analog comparators compare the signal at an input pin or at other internal signal sources with either an internal programmable voltage reference, an internal fixed reference, the DAC output or a second input pin. The comparator outputs are used to either drive an output pin, the Event System, or to generate an interrupt. The comparators can function in all operating modes including Stop Mode.

1.4.9. Temperature Sensor

The temperature sensor produces an analog output proportional to the device temperature. The signal is sent either to the ADC or to the analog comparators. The temperature sensor can function in all operating modes including Stop Mode.

1.4.10. Low-Voltage Detector

The low-voltage detector generates an interrupt when the supply voltage drops below a user-programmable level.

1.4.11. USB 2.0

The Full-Speed Universal Serial Bus (USB 2.0) device provides eight endpoints supporting bulk, control, and interrupt transfers. It contains an integrated USB-PHY and a PLL for transmit clocking.

1.4.12. Enhanced SPI

The enhanced SPI is a full-duplex, buffered, synchronous character-oriented channel which supports a four-wire interface.

1.4.13. UART with LIN, DALI, and DMX

A full-duplex 9-bit UART provides serial, asynchronous communication, and supports the Local Interconnect Network (LIN) and Digital Addressable Lighting Interface (DALI) serial communications protocols as well as Asynchronous Serial Digital Data Transmission Standard for Controlling Lighting Equipment and Accessories (DMX). The UART supports 8-bit and 9-bit data modes, selectable parity, and an efficient bus transceiver Driver Enable signal for controlling a multi-transceiver bus, such as a RS-485. The LIN bus is a cost-efficient, single-master, multiple-slave organization which supports speed up to 20 kilobits. Manchester encoding is supported for the DALI protocol.

1.4.14. Master/Slave I²C

The inter-integrated circuit (I²C) controller makes the F6482 Series products compatible with the I²C protocol. The I²C controller consists of two bidirectional bus lines:

- Serial data (SDA) line

- Serial clock (SCL) line

This I²C controller also supports Master, Slave, and Multi-Master operations.

1.4.15. Liquid Crystal Display

The Liquid Crystal Display (LCD) provides direct drive for shows containing up to 96 segments and supports static display, as well as multiplexing by 2, 3 and 4. Dedicated buffers store the LCD image, and an integrated charge pump is available to provide consistent drive levels despite varying supply voltage. In addition, the LCD is capable of contrast control and the automated blinking of individual segments.

1.4.16. Advanced Encryption Standard

The hardware accelerator for 128-bit Advanced Encryption Standard (AES) performs encryption and decryption according to FIPS PUB 197. The conversion throughput for each 128-bit block is 160 clock cycles for encryption and 176 clock cycles for decryption.

1.4.17. Timers

Three enhanced 16-bit reloadable timers are used for timing/counting events or motor control operations. These timers provide a 16-bit programmable reload counter and operate in One-Shot, Triggered One-Shot, Dual Input Triggered One-Shot, Continuous, Counter, PWM Single Output, PWM Dual Output, Capture, Capture Restart, Compare, Gated, Capture and Compare, and Demodulation modes. In addition to these three enhanced 16-bit timers, there are two basic 16-bit timers with interrupt functionality. The two timers are used as Baud Rate Generators (BRGs) when the UART is enabled, and configured as basic 16-bit timers when the UART is disabled.

1.4.18. Multi-Channel Timer

The multi-channel timer has a 16-bit up/down counter and a 4-channel Capture/Compare/PWM channel array. This timer enables the support of multiple synchronous Capture/Compare/PWM channels based on a single timer.

1.4.19. Real-Time Clock

The Real-Time Clock (RTC) supports both Counter and Clock modes. Alarms are available for seconds, minutes, hours, day of the week, and day of the month. The format for all count and alarm registers is selectable between binary and binary-coded decimal (BCD). Preconfigured dividers exist for 32.768kHz and 50/60Hz clock sources and a provision for calibrating a 32.768kHz clock source is provided.

1.4.20. Interrupt Controller

The F6482 Series of products supports up to forty-one interrupt sources with thirty interrupt vectors. These interrupts consist of up to twenty-five internal peripheral interrupts and up to sixteen GPIO pin interrupts. These interrupts feature three levels of programmable-interrupt priority.

1.4.21. Reset Controller

The F6482 Series products are reset using the $\overline{\text{RESET}}$ pin, POR, WDT time-out, Stop Mode exit, or VBO warning signal. The $\overline{\text{RESET}}$ pin is bidirectional; i.e., it functions as a reset source as well as a reset indicator.

1.4.22. On-Chip Debugger

The F6482 Series of products features an integrated OCD, which provides a rich set of debugging capabilities such as reading and writing registers, programming Flash memory, setting breakpoints and executing code. The OCD uses one single-pin interface for communication with an external host.

1.4.23. Direct Memory Access Controller

The F6482 Series features a 4-channel Direct Memory Access (DMA) for the efficient transfer of data between peripherals and/or memories without CPU intervention.

1.4.24. Event System

An 8-channel Event System provides communication between peripherals for autonomous triggering independent of CPU or DMA activity. Any Event System source can be selected to drive a signal on an Event System channel. The Event System is active in all operating modes, including Stop Mode.

1.5. Acronyms and Expansions

This document references the acronyms and expansions listed in Table 2.

Table 2. Acronyms and Expansions

Abbreviations/ Acronyms	Expansions
ADC	Analog-to-Digital Converter
AES	Advanced Encryption Standard
CI	Channel Interrupt
DALI	Digital Addressable Lighting Interface

Table 2. Acronyms and Expansions (Continued)

Abbreviations/ Acronyms	Expansions
DCO	Digitally Controlled Oscillator
DMA	Direct Memory Access
DMX	Asynchronous serial digital data transmission standard for controlling lighting equipment and accessories
Endec	Encoder/decoder
ESPI	Enhanced Serial Peripheral Interface
FLL	Frequency-Locked Loop
GPIO	General-Purpose Input/Output
HFXO	High Frequency Crystal Oscillator
I ² C	Inter-Integrated Circuit
I ² S	Inter-IC Sound
IPO	Internal Precision Oscillator
IRQ	Interrupt Request
ISR	Interrupt Service Routine
LCD	Liquid Crystal Display
LFXO	Low-Frequency Crystal Oscillator
LIN	Local Interconnect Network
LQFP	Low-Profile Quad Flat Package
LSB	Least-Significant Byte
LVD	Low-Voltage Detection
MSB	Most-Significant Byte
NVDS	Non-Volatile Data Storage
OCD	On-Chip Debugger
Op Amp	Operational Amplifier
PC	Program Counter
PDIP	Plastic Dual Inline Package
PHY	Physical layer device
PLL	Phase-Locked Loop
POR	Power-On Reset
PWM	Pulse-Width Modulation
QFN	Quad Flat No Lead
RTC	Real-Time Clock
SAR	Successive Approximation Register

Table 2. Acronyms and Expansions (Continued)

Abbreviations/ Acronyms	Expansions
SOIC	Small Outline Integrated Circuit
SPI	Serial Peripheral Interface
SSOP	Small Shrink Outline Package
TDM	Time Division Multiplexing
TI	Timer Interrupt
TTL	Transistor-Transistor Logic
UART	Universal Asynchronous Receiver/Transmitter
USB	Universal Serial Bus
VBO	Voltage Brown-Out
VCO	Voltage Controlled Oscillator
WDT	Watchdog Timer

Chapter 2. Pin Description

The F6482 Series products are available in a variety of package styles and pin configurations. This chapter describes the signals and available pin configurations for each of the package styles. To learn more about the physical package specifications, see the [Packaging](#) chapter on page 632.

2.1. Available Packages

Table 3 lists the package styles available for each device in the F6482 Series product line.

Table 3. F6482 Series Package Options

Part Number	LCD	32-Pin QFN	44-Pin QFN	44-Pin LQFP	64-Pin LQFP	80-Pin LQFP
Z8F6482	Yes				X	X
Z8F6082	Yes				X	X
Z8F3282	Yes				X	X
Z8F1682	Yes				X	X
Z8F6481	No	X	X	X	X	
Z8F6081	No	X	X	X	X	
Z8F3281	No	X	X	X	X	
Z8F1681	No	X	X	X	X	

2.2. Pin Configurations

Figures 2 through 6 show the pin configurations of all packages available in the F6482 Series. For signal descriptions, see [Table 4](#) on page 18.

At reset, all port pins default to an input state. In addition, any alternate functionality is not enabled; therefore the pins function as general-purpose input ports until programmed otherwise. At power-up, the Port D0 pin defaults to the RESET alternate function.

The pin configurations listed are preliminary and subject to change based on manufacturing limitations

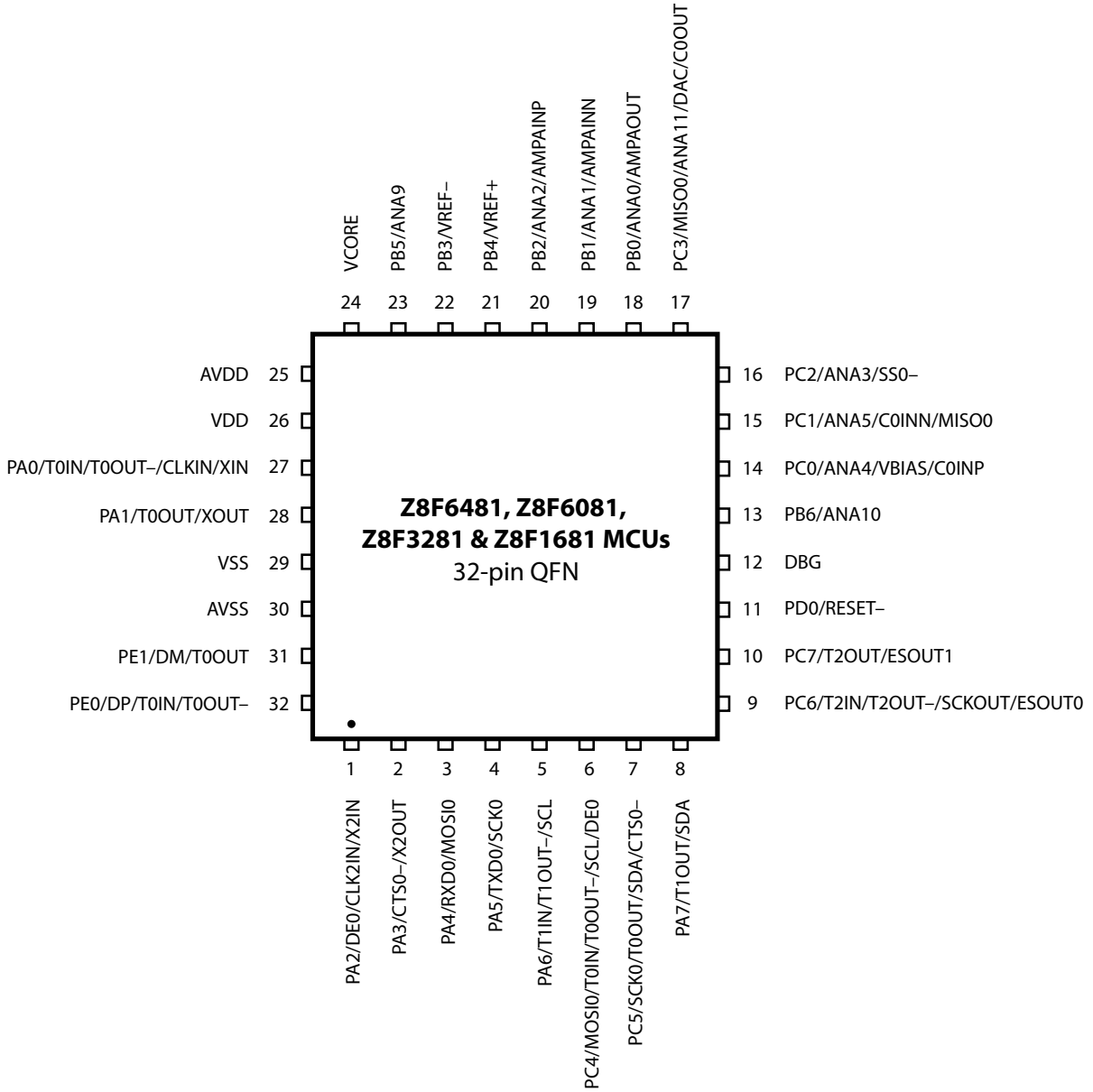

Figure 2. Z8F6481, Z8F6081, Z8F3281 and Z8F1681 MCUs, 32-Pin Quad Flat No Lead (QFN) Package

Note: It is recommended to connect the QFN bottom pad to V_{SS} .

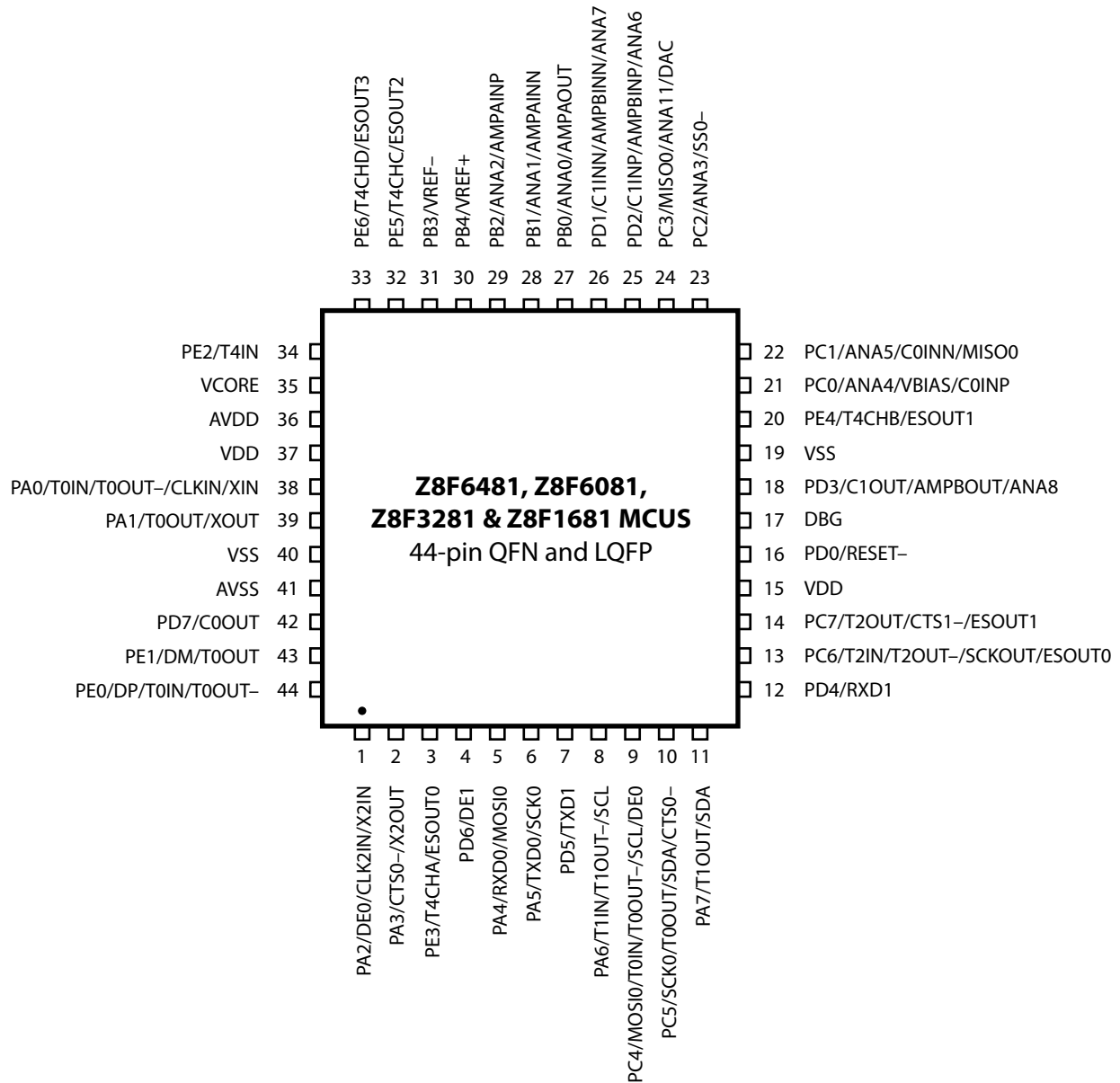

Figure 3. Z8F6481, Z8F6081, Z8F3281 & Z8F1681 MCUs, 44-Pin Quad Flat No Lead (QFN) and Low-Profile Quad Flat Package (LQFP)

► **Note:** It is recommended to connect the QFN bottom pad to V_{SS} .

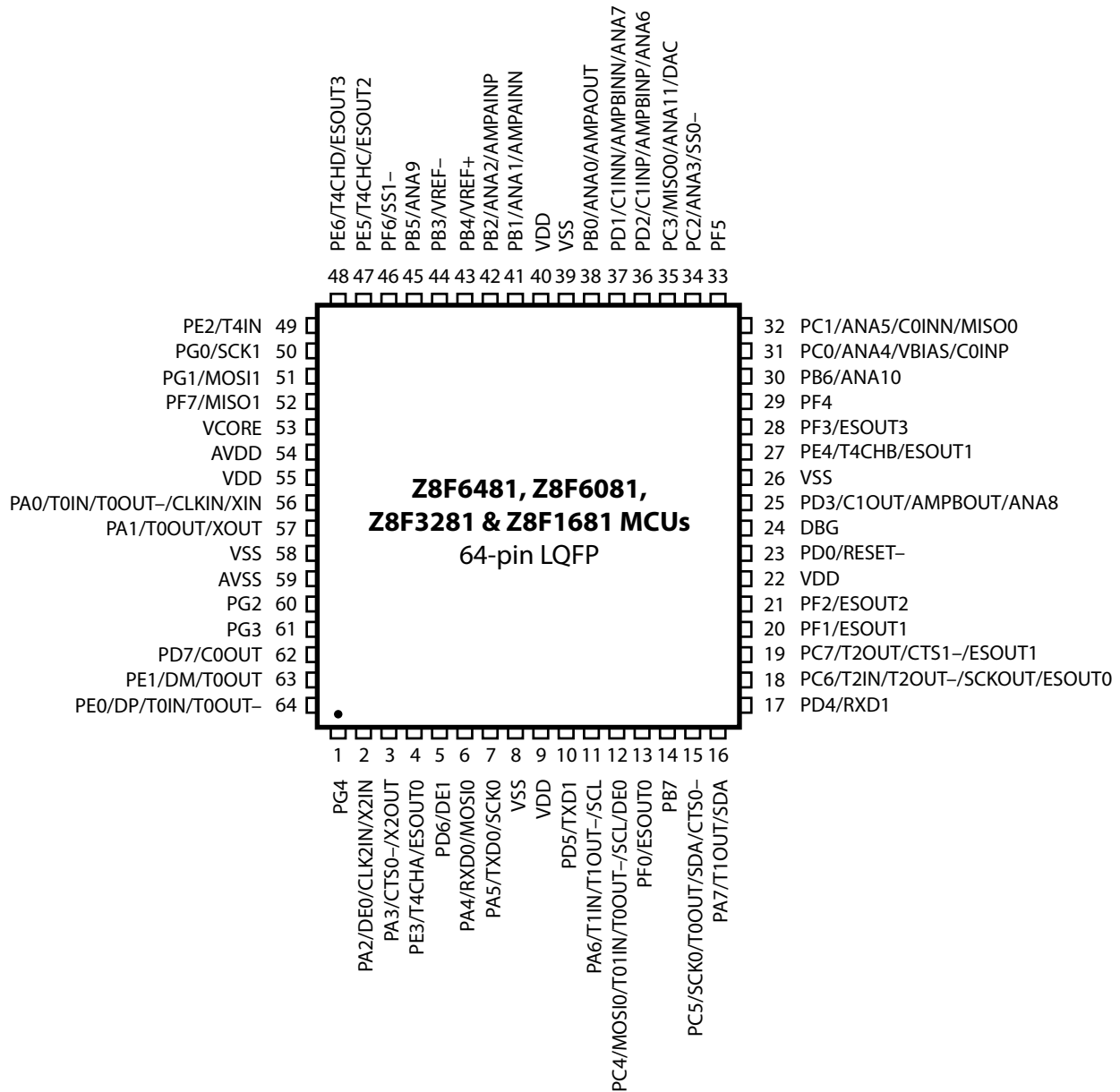

Figure 4. Z8F6481, Z8F6081 Z8F3281 & Z8F1681 MCUs, 64-Pin Low-Profile Quad Flat Package (LQFP)

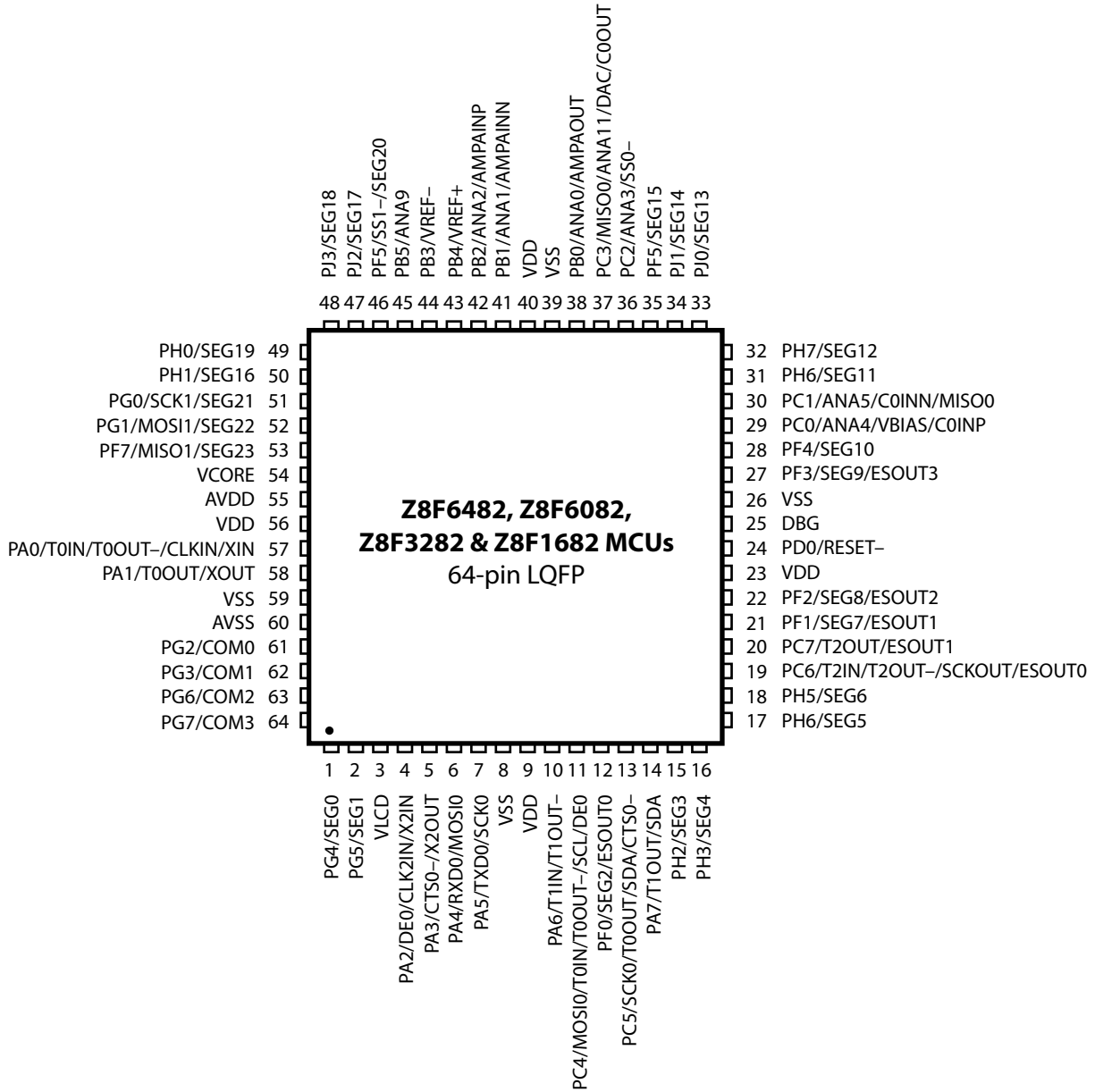

Figure 5. Z8F6482, Z8F6082, Z8F3282 & Z8F1682 MCUs, 64-Pin Low-Profile Quad Flat Package (LQFP)

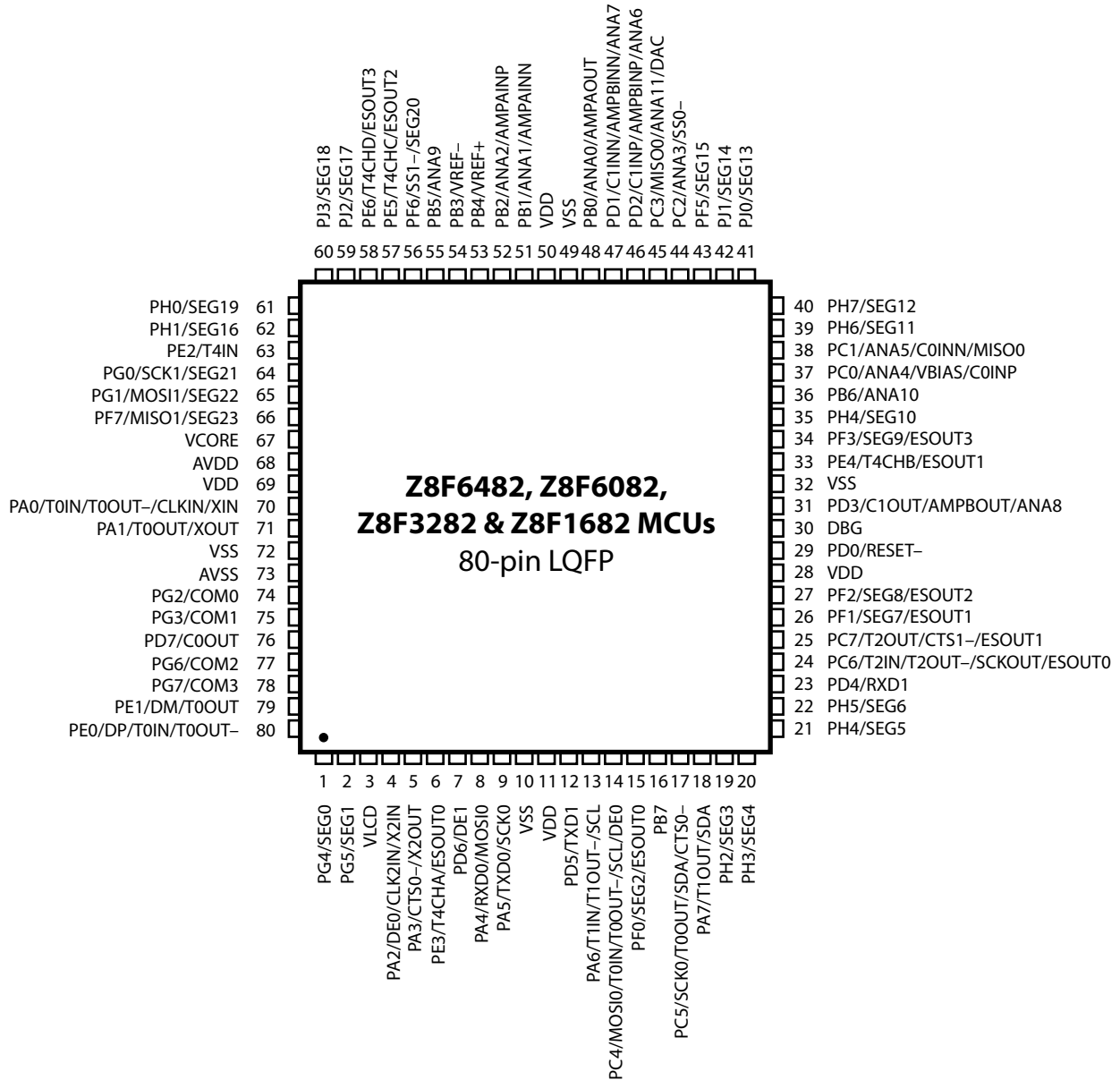

Figure 6. Z8F6482, Z8F6082, Z8F3282 & Z8F1682 MCUs, 80-Pin Low-Profile Quad Flat Package (LQFP)

2.3. Signal Descriptions

Table 4 lists the pin signals for all F6482 Series MCUs. To determine the signals for a specific package style, see the [Pin Configurations](#) section on page 12.

Table 4. Signal Descriptions

Signal Mnemonic	I/O	Description
General-Purpose I/O Ports A–E		
PA[7:0]	I/O	Port A: These pins are used for general-purpose I/O.
PB[7:0]	I/O	Port B: These pins are used for GPIO.
PC[7:0]	I/O	Port C: These pins are used for GPIO.
PD[7:0]	I/O	Port D: These pins are used for GPIO. PD0 is output only.
PE[6:0]	I/O	Port E: These pins are used for GPIO.
PF[7:0]	I/O	Port F: These pins are used for GPIO.
PG[7:0]	I/O	Port G: These pins are used for GPIO.
PH[7:0]	I/O	Port H: These pins are used for GPIO.
PJ[3:0]	I/O	Port J: These pins are used for GPIO.
UART-LDD Controllers		
TXD0/TXD1	O	Transmit Data 0–1 These signals are the transmit output from the UART0/1.
RXD0/RXD1	I	Receive Data 0–1 These signals are the receive input for the UART0/1.
CTS0/CTS1	I	Clear To Send 0–1 These signals are the flow control input for the UART0/1.
DE0/DE1	O	Driver Enable 0–1 These signals allow automatic control of external RS-485 drivers. These signals are approximately the inverse of the TXE (Transmit Empty) bit in the UART Status 0/1 Register. The DE0/1 signal can be used to ensure the external RS-485 driver is enabled when data is transmitted by the UART0/1.
I²C Controller		
SCL	I/O	I²C Serial Clock The I ² C Master supplies this signal. If the F6482 Series is the I ² C Master, this pin is an output and if it is I ² C slave, this pin is an input. When the GPIO pin is configured for alternate function to enable the SCL function, this pin is open-drain.
SDA	I/O	I²C Serial Data This open-drain pin transfers data between the I ² C and an external I ² C Master/Slave. When the GPIO pin is configured for alternate function to enable the SDA function, this pin is open-drain.

Table 4. Signal Descriptions (Continued)

Signal Mnemonic	I/O	Description
ESPI Controller		
SS0/SS1	I/O	Slave Select 0–1 These signals can be an output or an input. If the F6482 Series is the SPI 0–1 master, SS0/SS1 may be configured as the Slave Select output, and if it is the SPI 0–1 slave, SS0/SS1 is the input slave select.
SCK0/SCK1	I/O	SPI Serial Clock 0–1 The SPI master 0–1 supplies these signals. If the F6482 Series is the SPI master, SCLK0/SCLK1 is output and if it is the SPI slave, SCLK0/SCLK1 is an input.
MOSI0/MOSI1	I/O	Master Out Slave In 0–1 These signals are the data output from the SPI 0–1 master device and the data input to the SPI 0–1 slave device.
MISO0/MISO1	I/O	Master In Slave Out 0–1 These pins are the data input to the SPI 0–1 master device and the data output from the SPI 0–1 slave device.
USB		
DP/DM	I/O	USB data signals.
LCD		
SEG[23:0]	O	Segment Outputs Liquid Crystal Display (LCD) segment outputs.
COM[3:0]	O	Common Outputs Liquid Crystal Display (LCD) common outputs.
VLCD	I/O	Liquid Crystal Display (LCD) Supply Voltage When using the internal charge pump to drive VLCD, this pin should be decoupled with a 1 µF capacitor.
Event System		
ESOUT[3:0]	O	Event System Outputs
Timers		
T0OUT/T1OUT/ T2OUT	O	Timer Output 0–2 These signals are output from the timers.
T0OUT/T1OUT/ T2OUT	O	Timer Complement Output 0–2 These signals are output from the timers in PWM Dual Output Mode.
T0IN/T1IN/T2IN	I	Timer Input 0–2 These signals are used as the capture, gating, and counter inputs. The T0IN/T1IN/T2IN signal is multiplexed with T0OUT/T1OUT/T2OUT signals.

Table 4. Signal Descriptions (Continued)

Signal Mnemonic	I/O	Description
Multichannel Timers		
T4CHA, T4CHB, T4CHC, T4CHD	I/O	Multichannel Timer Input/Output These signals function as Capture input or Compare output for channels CHA, CHB, CHC, and CHD.
T4IN	I	Multichannel Timer clock input This signal allows external input to serve as the clock source for the Multichannel timer.
Comparators		
C0INP/C0INN, C1INP/C1INN	I	Comparator Inputs These signals are positive and negative inputs to the comparator 0 and comparator 1.
C0OUT/C1OUT	O	Comparator Outputs These are the output from the comparator 0 and the comparator 1.
Analog		
ANA[11:0]	I	Analog Port These signals are used as inputs to the ADC. The ANA0, ANA1, and ANA2 pins can also access the inputs and outputs of the integrated Op Amp A. The ANA6, ANA7, and ANA8 pins can also access the inputs and outputs of the integrated Op Amp B. ANA11 can access the DAC.
V _{REF+} /V _{REF-}	I/O	ADC Reference Voltage
VBIAS	O	Voltage Bias with Low Current Drive Capability
Operational Amplifiers, Op Amp A and Op Amp B		
AMPAINP /AMPAINN AMPBINP/ AMPBINN	I	Low-Power Operational Amplifier Inputs for Op Amp A and Op Amp B If enabled, these pins drive the positive and negative Operational Amplifier inputs respectively.
AMPAOUT AMPBOUT	O	Low-Power Operational Amplifier Outputs for Op Amp A and Op Amp B If enabled, this pin is driven by the on-chip, low-power Operational Amplifier.
Oscillators		
X _{IN}	I	High Frequency Crystal Input This is the input pin to the High Frequency Crystal Oscillator. A crystal can be connected between the pin and the X _{OUT} pin to form the oscillator.
X _{OUT}	O	High Frequency Crystal Output This pin is the output of the High Frequency Crystal Oscillator. A crystal can be connected between it and the X _{IN} pin to form the oscillator.

Table 4. Signal Descriptions (Continued)

Signal Mnemonic	I/O	Description
X2 _{IN}	I	Low Frequency Crystal Input The input pin to the Low Frequency Crystal Oscillator that operates at 32.768kHz. A crystal can be connected between the X2IN and the X2OUT pin to form the oscillator.
X2 _{OUT}	O	Low Frequency Crystal Output This pin is the output from the Low Frequency Crystal Oscillator. A crystal can be connected between the X2IN and the X2OUT pin to form the oscillator.
Clock Input/Output		
CLK _{IN}	I	Clock Input Signal This pin may be used to input a TTL-level signal to be used as the PLL input clock and/or as System Clock.
CLK2 _{IN}	I	Clock 2 Input Signal This pin may be used to input a TTL-level signal to be used as the Peripheral Clock.
SCK _{OUT}	O	System Clock Output Signal
On-Chip Debugger		
DBG	I/O	Debug This signal is the control and data input and output of the On-Chip Debugger. CAUTION: The DBG pin is open-drain and requires an external pull-up resistor to ensure proper operation.
Reset		
RESET	I/O	RESET Generates a Reset when asserted (driven Low). Also serves as a Reset indicator; the Z8 Encore! XP forces this pin Low when in Reset. This pin is open-drain and features an enabled internal pull-up resistor.
Power Supply		
V _{DD}	I	Digital Power Supply.
AV _{DD}	I	Analog Power Supply. AV _{DD} must be at the same potential as V _{DD} .
V _{SS}	I	Digital Ground.
AV _{SS}	I	Analog Ground. AV _{SS} must be at the same potential as V _{SS} .
V _{CORE}	I/O	Regulated core power supply (external current loading not permitted).
V _{LCD}	I/O	LCD Power Supply.
Note: V _{CORE} should be connected to a 4.7µF decoupling capacitor. V _{LCD} should be connected to a 1µF decoupling capacitor.		

Table 4. Signal Descriptions (Continued)

Signal Mnemonic	I/O	Description
External Pad		
EP		Bottom side Exterior Pad on QFN package This exterior pad is only available on the QFN package and it must be connected to V_{SS} .

2.4. Pin Characteristics

Table 5 lists the characteristics of each available pin on F6482 Series devices. The data in this table is sorted alphabetically by pin symbol mnemonic.

Table 5. Pin Characteristics

Symbol Mnemonic	Direction	Reset Direction	Active Low or Active High	Tristate Output	Internal Pull-Up or Pull-Down	Schmitt Trigger Input	Open-Drain Output
AV_{DD}	N/A	N/A	N/A	N/A	N/A	N/A	N/A
AV_{SS}	N/A	N/A	N/A	N/A	N/A	N/A	N/A
DBG	I/O	I	N/A	Yes	Yes	Yes	Yes
PA[7:0]	I/O	I	N/A	Yes	Programmable pull-up	Yes	Yes, programmable
PB[7:0]	I/O	I	N/A	Yes	Programmable pull-up	Yes	Yes, programmable
PC[7:0]	I/O	I	N/A	Yes	Programmable pull-up	Yes	Yes, programmable
PD[7:1]	I/O	I	N/A	Yes	Programmable pull-up	Yes	Yes, programmable
PD0/ RESET	I/O	I/O (defaults to $\overline{\text{RESET}}$)	Low (in RESET mode)	Yes (PD0 only)	Programmable for PD0; always ON for RESET	Yes	Programmable for PD0; always ON for RESET
PE[6:0]	I/O	I	N/A	Yes	Programmable pull-up	Yes	Yes, programmable
PF[7:0]	I/O	I	N/A	Yes	Programmable pull-up	Yes	Yes, programmable
PG[7:0]	I/O	I	N/A	Yes	Programmable pull-up	Yes	Yes, programmable

Table 5. Pin Characteristics (Continued)

Symbol Mnemonic	Direction	Reset Direction	Active Low or Active High	Tristate Output	Internal Pull-Up or Pull-Down	Schmitt Trigger Input	Open-Drain Output
PH[7:0]	I/O	I	N/A	Yes	Programmable pull-up	Yes	Yes, programmable
PJ[3:0]	I/O	I	N/A	Yes	Programmable pull-up	Yes	Yes, programmable
V _{CORE}	N/A	N/A	N/A	N/A	N/A	N/A	N/A
V _{DD}	N/A	N/A	N/A	N/A	N/A	N/A	N/A
V _{LCD}	N/A	N/A	N/A	N/A	N/A	N/A	N/A
V _{SS}	N/A	N/A	N/A	N/A	N/A	N/A	N/A

Chapter 3. Address Space

The eZ8 CPU can access the following three distinct address spaces:

- The Register File contains addresses for general-purpose registers, eZ8 CPU, peripherals, and GPIO port control registers
- The Program Memory contains addresses for all memory locations having executable code and/or data
- The Data Memory contains addresses for all memory locations that contain data only

These three address spaces are covered briefly in the following sections. To learn more about the eZ8 CPU and its address space, refer to the [eZ8 CPU Core User Manual \(UM0128\)](#), which is available free for download from the Zilog website.

3.1. Register File

The Register File address space in the Z8 Encore![®] MCU is 4KB (4096 bytes). The Register File is composed of two sections: control registers and general-purpose registers. When instructions are executed, registers defined as sources are read, and registers defined as destinations are written. The architecture of the eZ8 CPU allows all general-purpose registers to function as accumulators, address pointers, index registers, stack areas, or scratch pad memory.

The upper 256 bytes of the 4KB Register File address space are reserved for control of the eZ8 CPU, on-chip peripherals, and the input/output ports. These registers are located in the F00h to FFFh address range. Some of the addresses within the 256B control register sections are reserved; i.e., unavailable. Reading from a reserved Register File address returns an undefined value. Zilog does not recommend writing to the reserved Register File addresses because doing so can produce unpredictable results.

On-chip Register RAM always begins at address 000h in the Register File address space. F6482 Series devices contain 2KB or 3.75KB of on-chip Register RAM.

3.2. Program Memory

The eZ8 CPU supports 64KB of Program Memory address space. The F6482 Series devices contain 16KB to 64KB of on-chip Flash memory in the Program Memory address space, depending on the device.

Reading from Program Memory addresses present outside the available Flash memory returns FFh. Writing to these unimplemented Program Memory addresses produces no effect. Table 6 lists the Program Memory maps for the F6482 Series products.

Table 6. F6482 Series Program Memory Maps

Program Memory Address (Hex)	Function
Z8F6482 and Z8F6481 Products	
0000–0001	Flash option bits
0002–0003	Reset vector
0004–0005	WDT interrupt vector
0006–0007	Illegal instruction trap
0008–0047	Interrupt vectors*
0048–004B	Oscillator fail traps
004C–FFFF	Program Flash
Z8F6082 and Z8F6081 Products	
0000–0001	Flash option bits
0002–0003	Reset vector
0004–0005	WDT interrupt vector
0006–0007	Illegal instruction trap
0008–0047	Interrupt vectors*
0048–004B	Oscillator fail traps*
004C–EFFF	Program Flash
F000	NVDS byte read
F3FD	NVDS byte write
Z8F3282 and Z8F3281 Products	
0000–0001	Flash option bits
0002–0003	Reset vector
0004–0005	WDT interrupt vector
0006–0007	Illegal instruction trap
0008–0047	Interrupt vectors*
0048–004B	Oscillator fail traps*
004C–7FFF	Program Flash
F000	NVDS byte read
F3FD	NVDS byte write

Note: *See [Table 51](#) on page 128 for a list of interrupt vectors and traps.

Table 6. F6482 Series Program Memory Maps (Continued)

Program Memory Address (Hex)	Function
Z8F1682 and Z8F1681 Products (Continued)	
0000–0001	Flash option bits
0002–0003	Reset vector
0004–0005	WDT interrupt vector
0006–0007	Illegal instruction trap
0008–0047	Interrupt vectors*
0048–004B	Oscillator fail traps*
004C–3FFF	Program Flash
F000	NVDS byte read
F3FD	NVDS byte write

Note: *See [Table 51](#) on page 128 for a list of interrupt vectors and traps.

3.3. Data Memory

F6482 Series MCUs do not use the eZ8 CPU’s 64KB Data Memory address space.

3.4. Flash Information Area

Table 7 lists the F6482 Series Flash Information Area. This 1KB space consists of two pages and is accessed by setting bit 7 of the Flash Page Select Register to 1. When access is enabled, the Flash Information Area is mapped into Program Memory and overlays the FC00h to FFFFh address range. When Information Area access is enabled, all reads from these Program Memory addresses return the Information Area data rather than the Program Memory data. Access to the Flash Information Area is read-only.

Table 7. F6482 Series Flash Memory Information Area Map

Program Memory Address (Hex)	Function
FC00–FC3F	Zilog option bits.
FC40–FC53	Part number: a 20-character ASCII alphanumeric code, left-justified and filled with Fh.
FC54–FC5F	Reserved.
FC60–FC7F	Zilog calibration data.
FC80–FFFF	Reserved.

Chapter 4. Register Map

Table 8 provides the address map for the Register File of F6482 Series devices. Not all devices and package styles in the F6482 Series support the LCD or all of the GPIO Ports. Consider registers for unimplemented peripherals as Reserved.

Table 8. Register File Address Map

Address (Hex)	Register Description	Mnemonic	Reset (Hex)	Page #
General-Purpose RAM				
Z8F6842, Z8F6481, Z8F6082, Z8F6081, Z8F3282, Z8F3281 Devices				
000–EFF	General-Purpose Register File RAM	–	XX	
Z8F1682, Z8F1681 Devices				
000–7FF	General-Purpose Register File RAM		XX	
800–EFF	Reserved		XX	
Special-Purpose Registers				
Timer 0				
F00	Timer 0 High Byte	T0H	00	175
F01	Timer 0 Low Byte	T0L	01	175
F02	Timer 0 Reload High Byte	T0RH	FF	176
F03	Timer 0 Reload Low Byte	T0RL	FF	176
F04	Timer 0 PWM0 High Byte	T0PWM0H	00	177
F05	Timer 0 PWM0 Low Byte	T0PWM0L	00	177
F06	Timer 0 Control 0	T0CTL0	00	179
F07	Timer 0 Control 1	T0CTL1	00	180
F20	Timer 0 PWM1 High Byte	T0PWM1H	00	178
F21	Timer 0 PWM1 Low Byte	T0PWM1L	00	178
F22	Timer 0 Control 2	T0CTL2	00	184
F23	Timer 0 Status	T0STA	00	185
F2C	Timer 0 Noise Filter Control	T0NFC	00	186
Timer 1				
F08	Timer 1 High Byte	T1H	00	175
F09	Timer 1 Low Byte	T1L	01	175
F0A	Timer 1 Reload High Byte	T1RH	FF	176

Table 8. Register File Address Map (Continued)

Address (Hex)	Register Description	Mnemonic	Reset (Hex)	Page #
Timer 1 (Continued)				
F0B	Timer 1 Reload Low Byte	T1RL	FF	176
F0C	Timer 1 PWM0 High Byte	T1PWM0H	00	177
F0D	Timer 1 PWM0 Low Byte	T1PWM0L	00	177
F0E	Timer 1 Control 0	T1CTL0	00	179
F0F	Timer 1 Control 1	T1CTL1	00	180
F24	Timer 1 PWM1 High Byte	T1PWM1H	00	178
F25	Timer 1 PWM1 Low Byte	T1PWM1L	00	178
F26	Timer 1 Control 2	T1CTL2	00	184
F27	Timer 1 Status	T1STA	00	185
F2D	Timer 1 Noise Filter Control	T1NFC	00	186
Timer 2				
F10	Timer 2 High Byte	T2H	00	175
F11	Timer 2 Low Byte	T2L	01	175
F12	Timer 2 Reload High Byte	T2RH	FF	176
F13	Timer 2 Reload Low Byte	T2RL	FF	176
F14	Timer 2 PWM0 High Byte	T2PWM0H	00	177
F15	Timer 2 PWM0 Low Byte	T2PWM0L	00	177
F16	Timer 2 Control 0	T2CTL0	00	179
F17	Timer 2 Control 1	T2CTL1	00	180
F18–F1F	Reserved	–	XX	
F28	Timer 2 PWM1 High Byte	T2PWM1H	00	180
F29	Timer 2 PWM1 Low Byte	T2PWM1L	00	178
F2A	Timer 2 Control 2	T2CTL2	00	184
F2B	Timer 2 Status	T2STA	00	185
F2E	Timer 2 Noise Filter Control	T2NFC	00	186
F2F	Reserved	–	XX	
RTC				
F30	Real-Time Clock Seconds	RTC_SEC	XX	213
F31	Real-Time Clock Minutes	RTC_MIN	XX	214
F32	Real-Time Clock Hours	RTC_HRS	XX	216
F33	Real-Time Clock Day-of-the-Month	RTC_DOM	XX	217

Table 8. Register File Address Map (Continued)

Address (Hex)	Register Description	Mnemonic	Reset (Hex)	Page #
RTC (Continued)				
F34	Real-Time Clock Day-of-the-Week	RTC_DOW	0X	218
F35	Real-Time Clock Month	RTC_MON	XX	219
F36	Real-Time Clock Year	RTC_YR	XX	220
F37	Real-Time Clock Alarm Seconds	RTC_ASEC	XX	221
F38	Real-Time Clock Alarm Minutes	RTC_AMIN	XX	222
F39	Real-Time Clock Alarm Hours	RTC_AHRS	XX	223
F3A	Real-Time Clock Alarm Day-of-the-Month	RTC_ADOM	XX	224
F3B	Real-Time Clock Alarm Day-of-the-Week	RTC_ADOW	0X	225
F3C	Real-Time Clock Alarm Control	RTC_ACTRL	00	226
F3D	Reserved	–	XX	–
F3E	Real-Time Clock Timing	RTC_TIM	00	228
F3F	Real-Time Clock Control	RTC_CTRL	00	229
LDD UART 0				
F40	LDD UART0 Transmit Data	U0TXD	XX	258
	LDD UART0 Receive Data	U0RXD	XX	258
F41	LDD UART0 Status 0 – Standard UART Mode	U0STAT0	0000011Xb	259
	LDD UART0 Status 0 – LIN Mode	U0STAT0	00000110b	260
	LDD UART0 Status 0 – DALI Mode	U0STAT0	0000011Xb	262
	LDD UART0 Status 0 – DMX Mode	U0STAT0	0000011Xb	263
F42	LDD UART0 Control 0	U0CTL0	00	267
F43	LDD UART0 Control 1 – Multiprocessor Control	U0CTL1	00	269
	LDD UART0 Control 1 – Noise Filter Control	U0CTL1	00	271
	LDD UART0 Control 1 – LIN Control	U0CTL1	00	272
	LDD UART0 Control 1 – DALI Control	U0CTL1	00	273
	LDD UART0 Control 1 – DMX Control	U0CTL1	00	274
F44	LIN UART0 Mode Select and Status	U0MDSTAT	00	264
F45	UART0 Address Compare	U0ADDR	00	276
F46	UART0 Baud Rate High Byte	U0BRH	FF	276
LDD UART 0 (Continued)				
F47	UART0 Baud Rate Low Byte	U0BRL	FF	277

Table 8. Register File Address Map (Continued)

Address (Hex)	Register Description	Mnemonic	Reset (Hex)	Page #
LDD UART 1				
F48	LDD UART1 Transmit Data	U1TXD	XX	258
	LDD UART1 Receive Data	U1RXD	XX	258
F49	LDD UART1 Status 0 – Standard UART Mode	U1STAT0	0000011 Xb	259
	LDD UART1 Status 0 – LIN Mode	U1STAT0	0000011 0b	260
	LDD UART1 Status 0 – DALI Mode	U1STAT0	0000011 Xb	262
	LDD UART1 Status 0 – DMX Mode	U1STAT0	0000011 Xb	263
F4A	LDD UART1 Control 0	U1CTL0	00	267
F4B	LDD UART1 Control 1 – Multiprocessor Control	U1CTL1	00	269
	LDD UART1 Control 1 – Noise Filter Control	U1CTL1	00	271
	LDD UART1 Control 1 – LIN Control	U1CTL1	00	272
	LDD UART1 Control 1 – DALI Control	U1CTL1	00	273
	LDD UART1 Control 1 – DMX Control	U1CTL1	00	274
F4C	LDD UART1 Mode Select and Status	U1MDSTAT	00	264
F4D	UART1 Address Compare	U1ADDR	00	276
F4E	UART1 Baud Rate High Byte	U1BRH	FF	276
F4F	UART1 Baud Rate Low Byte	U1BRL	FF	277
I²C				
F50	I ² C Data	I2CDATA	00	329
F51	I ² C Interrupt Status	I2CISTAT	80	330
F52	I ² C Control	I2CCTL	00	331
F53	I ² C Baud Rate High Byte	I2CBRH	FF	333
F54	I ² C Baud Rate Low Byte	I2CBRL	FF	333
F55	I ² C State	I2CSTATE	02	334
F56	I ² C Mode	I2CMODE	00	337
F57	I ² C Slave Address	I2CSLVAD	00	339
USB				
F58	Reserved	–	XX	

Table 8. Register File Address Map (Continued)

Address (Hex)	Register Description	Mnemonic	Reset (Hex)	Page #
F59	USB Subaddress	USBSA	00	358
F5A	USB Subdata	USBSD	00	359
F5B	USB Control	USBCTL	00	360
F5C	USB DMA 0 Control	USBDMA0CTL	00	361
F5D	USB DMA 1 Control	USBDMA1CTL	00	361
F5E	USB DMA Data	USBDMADATA	00	362
F5F	USB Interrupt Control	USBIRQCTL	00	363
Enhanced Serial Peripheral Interface (ESPI)				
F60	ESPI0 Data	ESPI0DATA	XX	296
F61	ESPI0 Transmit Data Command	ESPI0TDCR	00	296
F62	ESPI0 Control	ESPI0CTL	00	297
F63	ESPI0 Mode	ESPI0MODE	00	299
F64	ESPI0 Status	ESPI0STAT	81	301
F65	ESPI0 State	ESPI0STATE	00	302
F66	ESPI0 Baud Rate High Byte	ESPI0BRH	FF	304
F67	ESPI0 Baud Rate Low Byte	ESPI0BRL	FF	305
F68	ESPI1 Data	ESPI1DATA	XX	296
F69	ESPI1 Transmit Data Command	ESPI1TDCR	00	296
F6A	ESPI1 Control	ESPI1CTL	00	297
F6B	ESPI1 Mode	ESPI1MODE	00	299
F6C	ESPI1 Status	ESPI1STAT	81	301
F6D	ESPI1 State	ESPI1STATE	00	302
F6E	ESPI1 Baud Rate High Byte	ESPI1BRH	FF	304
F6F	ESPI1 Baud Rate Low Byte	ESPI1BRL	FF	305
Analog-to-Digital Converter (ADC)				
F70	ADC Control 0	ADCCTL0	00	452
F71	ADC Control 1	ADCCTL1	00	454
F72	ADC Control 2	ADCCTL2	00	455
F73	ADC Input Select High	ADCINSH	00	456
F74	ADC Input Select Low	ADCINSL	00	456
Analog-to-Digital Converter (ADC) (Continued)				
F75	ADC Offset Calibration	ADCOFF	00	459

Table 8. Register File Address Map (Continued)

Address (Hex)	Register Description	Mnemonic	Reset (Hex)	Page #
F76	ADC Data High	ADCD_H	00	460
F77	ADC Data Low	ADCD_L	00	460
F78	Sample Time	ADCST	00	461
F79	ADC Upper Window Threshold High	ADCUWINH	FF	462
F7A	ADC Upper Window Threshold Low	ADCUWINL	FF	463
F7B	ADC Lower Window Threshold High	ADCLWINH	00	464
F7C	ADC Lower Window Threshold Low	ADCLWINL	00	465
Digital-to-Analog Converter (DAC)				
F7D	DAC Control	DACCTL	00	470
F7E	DAC Data High	DACD_H	00	472
F7F	DAC Data Low	DACD_L	00	472
Low-Power Control				
F80	Power Control 0	PWRCTL0	10	52
F81	Power Control 1	PWRCTL1	00	54
Clock System				
F82	Clock Control 0	CLKCTL0	00	115
F83	Clock Control 1	CLKCTL1	01	116
F84	Clock Control 2	CLKCTL2	00	117
F85	Clock Control 3	CLKCTL3	08	119
F86	Clock Control 4	CLKCTL4	00	119
F87	Clock Control 5	CLKCTL5	05	120
F88	Clock Control 6	CLKCTL6	00	121
F89	Clock Control 7	CLKCTL7	00	122
F8A	Clock Control 8	CLKCTL8	XX	122
F8B	Clock Control 9	CLKCTL9	XX	123
F8C	Clock Control A	CLKCTLA	00	123
F8D	Clock Control B	CLKCTLB	00	125
F8E	Clock Control C	CLKCTLC	00	126
Comparators				
F8F	Comparator Control	CMPCTL	00	494
F90	Comparator 0 Control 0	CMP0CTL0	00	495
F91	Comparator 0 Control 1	CMP0CTL1	00	496

Table 8. Register File Address Map (Continued)

Address (Hex)	Register Description	Mnemonic	Reset (Hex)	Page #
F92	Comparator 1 Control 0	CMP1CTL0	00	497
F93	Comparator 1 Control 1	CMP1CTL1	00	498
Op Amp_A				
F94	Op Amp_A Control 0	AMPACTL0	00	481
F95	Op Amp_A Control 1	AMPACTL1	00	482
Op Amp_B				
F96	Op Amp_B Control 0	AMPBCTL0	00	483
F97	Op Amp_B Control 1	AMPBCTL1	00	484
Event System				
F98	Event System Source Subaddress	ESSSA	00	418
F99	Event System Source Subdata	ESSSD	00	419
F9A	Event System Destination Subaddress	ESDSA	00	421
F9B	Event System Destination Subdata	ESDSD	00	422
F9C-F9F	Reserved			
Multi-Channel Timer				
FA0	MCT High Byte	MCTH	00	197
FA1	MCT Low Byte	MCTL	00	197
FA2	MCT Reload High Byte	MCTRH	FF	198
FA3	MCT Reload Low Byte	MCTRL	FF	198
FA4	MCT Subaddress	MCTSA	XX	198
FA5	MCT Subregister 0	MCTSR0	XX	199
FA6	MCT Subregister 1	MCTSR1	XX	199
FA7	MCT Subregister 2	MCTSR2	XX	199
DMA Controller				
FA8	DMA 0 Subaddress/Status	DMA0SA	00	400
FA9	DMA 0 Subdata	DMA0SD	00	401
FAA	DMA 1 Subaddress/Status	DMA1SA	00	400
FAB	DMA 1 Subdata	DMA1SD	00	401
DMA Controller (Continued)				
FAC	DMA 2 Subaddress/Status	DMA2SA	00	400
FAD	DMA 2 Subdata	DMA2SD	00	401
FAE	DMA 3 Subaddress/Status	DMA3SA	00	400

Table 8. Register File Address Map (Continued)

Address (Hex)	Register Description	Mnemonic	Reset (Hex)	Page #
FAF	DMA 3 Subdata	DMA3SD	00	401
FB0	DMA Control	DMACTL	00	402
Liquid Crystal Display (LCD)				
FB1	LCD Subaddress	LCDSA	00	520
FB2	LCD Subdata	LCSDS	XX	521
FB3	LCD Clock	LCDCLK	00	522
FB4	LCD Control 0	LCDCTL0	00	523
FB5	LCD Control 1	LCDCTL1	00	524
FB6	LCD Control 2	LCDCTL2	00	526
FB7	LCD Control 3	LCDCTL3	00	527
AES				
FB8	AES Data	AESDATA	XX	435
	AES Initialization Vector	AESIV	XX	436
FB9	AES Key	AESKEY	XX	436
FBA	AES Control	AESCTL	00	437
FBB	AES Status	AESSTAT	00	438
PORT J				
FBC	Port J Address	PJADDR	00	86
FBD	Port J Control	PJCTL	00	87
FBE	Port J Input Data	PJIN	XX	94
FBF	Port J Output Data	PJOUT	00	95
Interrupt Controller				
FC0	Interrupt Request 0	IRQ0	00	133
FC1	IRQ0 Enable High Bit	IRQ0ENH	00	137
FC2	IRQ0 Enable Low Bit	IRQ0ENL	00	138
FC3	Interrupt Request 1	IRQ1	00	134
FC4	IRQ1 Enable High Bit	IRQ1ENH	00	139
FC5	IRQ1 Enable Low Bit	IRQ1ENL	00	140
Interrupt Controller (Continued)				
FC6	Interrupt Request 2	IRQ2	00	135
FC7	IRQ2 Enable High Bit	IRQ2ENH	00	141
FC8	IRQ2 Enable Low Bit	IRQ2ENL	00	141

Table 8. Register File Address Map (Continued)

Address (Hex)	Register Description	Mnemonic	Reset (Hex)	Page #
FC9	Interrupt Request 3	IRQ3	00	136
FCA	IRQ3 Enable High Bit	IRQ3ENH	00	142
FCB	IRQ3 Enable Low Bit	IRQ3ENL	00	144
FCC	Interrupt Edge Select	IRQES	00	145
FCD	Shared Interrupt Select 0	IRQSS0	00	146
FCE	Shared Interrupt Select 1	IRQSS1	00	147
FCF	Interrupt Control	IRQCTL	00	148
GPIO Port A				
FD0	Port A Address	PAADDR	00	86
FD1	Port A Control	PACTL	00	87
FD2	Port A Input Data	PAIN	XX	94
FD3	Port A Output Data	PAOUT	00	95
GPIO Port B				
FD4	Port B Address	PBADDR	00	86
FD5	Port B Control	PBCTL	00	87
FD6	Port B Input Data	PBIN	XX	94
FD7	Port B Output Data	PBOUT	00	95
GPIO Port C				
FD8	Port C Address	PCADDR	00	86
FD9	Port C Control	PCCTL	00	87
FDA	Port C Input Data	PCIN	XX	94
FDB	Port C Output Data	PCOUT	00	95
GPIO Port D				
FDC	Port D Address	PDADDR	00	86
FDD	Port D Control	PDCTL	00	87
FDE	Port D Input Data	PDIN	XX	94
PDF	Port D Output Data	PDOUT	00	95
GPIO Port E				
FE0	Port E Address	PEADDR	00	86
FE1	Port E Control	PECTL	00	87
FE2	Port E Input Data	PEIN	XX	94
FE3	Port E Output Data	PEOUT	00	95

Table 8. Register File Address Map (Continued)

Address (Hex)	Register Description	Mnemonic	Reset (Hex)	Page #
GPIO Port F				
FE4	Port F Address	PFADDR	00	86
FE5	Port F Control	PFCTL	00	87
FE6	Port F Input Data	PFIN	XX	94
FE7	Port F Output Data	PFOUT	00	95
GPIO Port G				
FE8	Port G Address	PGADDR	00	86
FE9	Port G Control	PGCTL	00	87
FEA	Port G Input Data	PGIN	XX	94
FEB	Port G Output Data	PGOUT	00	95
GPIO Port H				
FEC	Port H Address	PHADDR	00	86
FED	Port H Control	PHCTL	00	87
FEE	Port H Input Data	PHIN	XX	94
FEF	Port H Output Data	PHOUT	00	95
Reset				
FF0	Reset Status	RSTSTAT	XX	48
FF1	Reserved	–	XX	
Watchdog Timer				
FF2	Watchdog Timer Reload High Byte	WDTH	FF	209
FF3	Watchdog Timer Reload Low Byte	WDTL	FF	209
FF4–FF5	Reserved	–	XX	
Trim Bit Control				
FF6	Trim Bit Address	TRMADR	00	545
FF7	Trim Data	TRMDR	XX	546
Flash Memory Controller				
FF8	Flash Control	FCTL	00	538
	Flash Status	FSTAT	00	538
FF9	Flash Page Select	FPS	00	539
	Flash Block Protect	FPROT	00	540
FFA	Flash Programming Configuration	FPCONFIG	00	541
FFB	Reserved	–	XX	



Table 8. Register File Address Map (Continued)

Address (Hex)	Register Description	Mnemonic	Reset (Hex)	Page #
eZ8 CPU				
FFC	Flags	–	XX	Refer to the eZ8 CPU Core User Manual (UM0128)
FFD	Register Pointer	RP	XX	
FFE	Stack Pointer High Byte	SPH	XX	
FFF	Stack Pointer Low Byte	SPL	XX	
Note: XX = undefined.				

Chapter 5. Reset, Stop-Mode Recovery and Low-Voltage Detection

The Reset Controller within the F6482 Series MCU controls Reset and Stop-Mode Recovery operations and provides indication of low-voltage supply conditions. During the operation, the following events cause a Reset:

- Power-On Reset (POR)
- Voltage Brown-Out (VBO) protection
- Watchdog Timer (WDT) time-out (when configured by the WDT_RES Flash option bit to initiate a Reset)
- External $\overline{\text{RESET}}$ pin assertion (when the alternate function, RESET, is enabled by the GPIO register)
- On-Chip Debugger initiated Reset (OCDCTL[0] set to 1)

When the device is in Stop Mode, a Stop-Mode Recovery can be initiated by each of the following triggers:

- Watchdog Timer time-out
- GPIO Port input pin transition on an enabled Stop-Mode Recovery source
- Interrupt from a timer, comparator, Low Voltage Detection or RTC operating in Stop Mode

The low-voltage detection circuitry on the device offers the following features:

- The low-voltage detection threshold level is user-defined
- It generates an interrupt when the supply voltage drops below a user-defined level

5.1. Reset Types

The F6482 Series MCU provides multiple types of Reset operation. Stop-Mode Recovery is considered a form of Reset. Table 9 lists the types of Reset and their operating characteristics.

Table 9. Reset, Stop-Mode Recovery Characteristics and Latency

Reset Type	Reset Characteristics and Latency		
	Control Registers	eZ8 CPU	Reset Latency (Delay)
System Reset (non-POR/VBO Reset)	Reset (as applicable)	Reset	10ms Reset Delay
System Reset (POR/VBO Reset)	Reset (as applicable)	Reset	10ms Reset Delay
Stop-Mode Recovery (standard, FRECOV = 0)	Unaffected, except RSTSTAT, CLKCTL0, CLKCTL5, and IRQCTL registers	Reset	6 System Clock (DCO selected) cycles after Stop-Mode Recovery Delay
Stop-Mode Recovery (fast, FRECOV = 1)	Unaffected, except RSTSTAT CLKCTL0, CLKCTL5, and IRQCTL registers	Reset	6 System Clock (DCO selected) cycles

5.2. System Reset

During a System Reset, the IPO and DCO are enabled but the FLL is disabled. Additionally, the IPO is selected as Peripheral Clock (PCLK) and the DCO configured to nominally operate at approximately 0.8 MHz. Upon the conclusion of a System Reset, the System Clock source and clock settings can be configured as desired. To learn more, see the [Clock System](#) chapter on page 96.

When System Reset occurs due to a VBO condition, the Reset Delay commences when the supply voltage first exceeds the VBO level (discussed later in this chapter). When System Reset occurs due to a POR condition, the Reset Delay commences from when the supply voltage first exceeds both the the POR and VBO levels. If the external RESET pin remains asserted at the end of the Reset period, the device remains in System Reset until the pin is deasserted.

At the beginning of System Reset, all GPIO pins are configured as inputs with pull-up resistor disabled, except PD0 that is shared with the Reset pin. On Reset, the Port D0 pin is configured as a bidirectional open-drain Reset. The pin is internally driven Low during port reset, after which the user code can reconfigure this pin as a general-purpose output.

During Reset, the eZ8 CPU and on-chip peripherals are idle; however, the Internal Precision Oscillator (IPO) continues to function.

On System Reset, control registers within the Register File that have a defined Reset value are loaded with their Reset values. Other control registers (including the Stack Pointer, Register Pointer and Flags) and general-purpose RAM are not initialized and undefined following System Reset. The eZ8 CPU fetches the Reset vector at Program Memory

addresses 0002h and 0003h and loads that value into the Program Counter. Program execution begins at the Reset vector address.

Because the control registers are reinitialized by a System Reset, the system clock after reset is always the DCO configured to run at approximately 1MHz. User software must reconfigure the Clock System such that the desired system clock source is enabled and selected.

► **Note:** After a System Reset or Stop-Mode Recovery, an external crystal oscillator may be unstable. Use software to wait until it is stable before using it as a clock source.

Table 10 lists the possible sources of a System Reset.

Table 10. System Reset Sources and Resulting Reset Type

Operating Mode	System Reset Source	Special Conditions
Normal or Halt Mode	Power-On Reset	Reset delay begins after supply voltage exceeds POR and VBO levels.
	Voltage Brown-Out	Reset delay begins after supply voltage exceeds VBO level.
	Watchdog Timer time-out when configured for Reset	Reset delay begins upon Watchdog Timer time-out.
	RESET pin assertion	Reset delay begins after RESET pin assertion. All reset pulses less than three system clocks in width are ignored, see the Electrical Characteristics chapter on page 601.
	On-Chip Debugger initiated Reset (OCDCTL[0] set to 1)	Reset delay begins upon OCDCTL[0] set to 1. System Reset, except the OCD is unaffected
Stop Mode	Power-On Reset	Reset delay begins after supply voltage exceeds POR and VBO levels.
	Voltage Brown-Out	Reset delay begins after supply voltage exceeds VBO level.
	RESET pin assertion	Reset delay begins after RESET pin assertion. All reset pulses less than the specified analog delay are ignored, see the Electrical Characteristics chapter on page 601.
	DBG pin driven Low	None.

5.2.1. Power-On Reset

Each device in the F6482 Series contains an internal Power-On Reset (POR) circuit. The POR circuit monitors the supply voltage and holds the whole device in the Reset state until

the supply voltage reaches a safe circuit operating level when the device is powered on. V_{DD} must be greater than both V_{POR} and V_{VBO} to exit the Reset state.

After power on, the POR circuit keeps idle until the supply voltage drops below V_{TH} voltage. [Figure 8](#) on page 42 shows this POR behavior.

After the F6482 Series MCU exits the POR state, the eZ8 CPU fetches the Reset vector. Following this POR, the POR/VBO status bit in the Reset Status Register is set to 1.

For the POR threshold voltage (V_{POR}) and POR start voltage V_{TH} , see the [Electrical Characteristics](#) chapter on page 601.

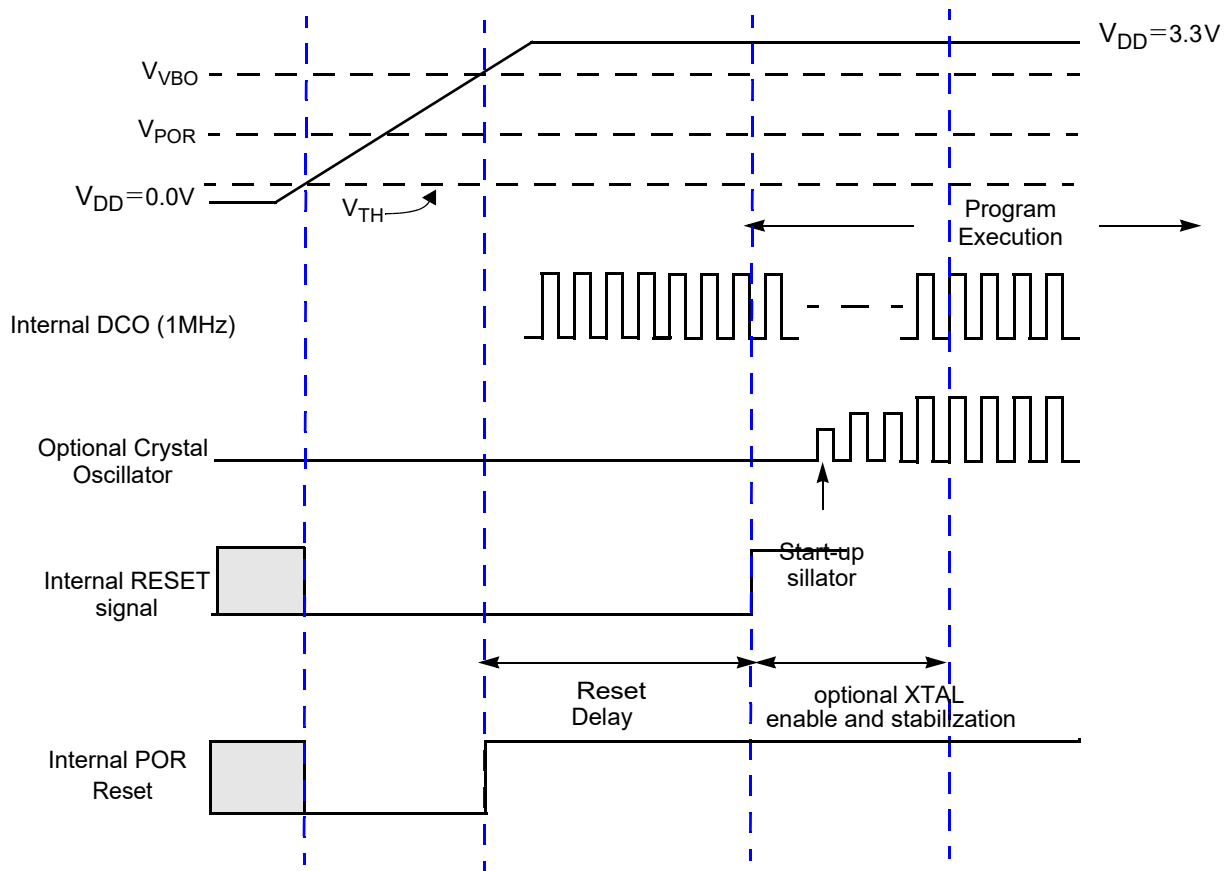

Notes

1. Not to Scale.
2. Internal Reset and POR Reset are Low active.

 undefined

Figure 7. Power-On Reset Operation

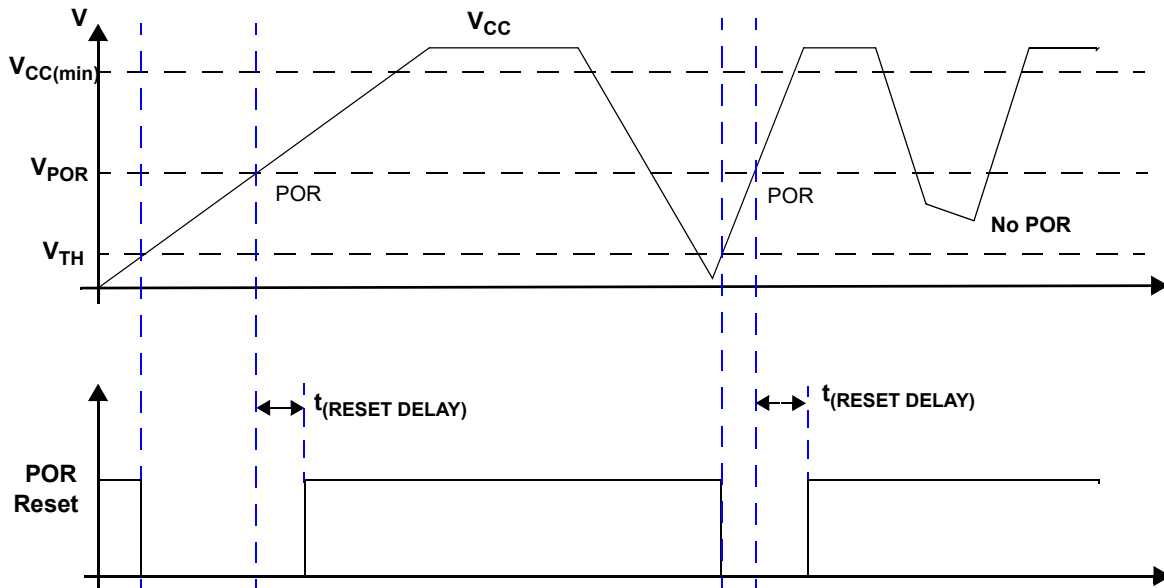

Figure 8. Power-On Reset Behavior

5.2.2. Voltage Brown-Out Reset

The F6482 Series MCU provides a VBO Reset feature for low-voltage protection. The VBO circuit has a preset threshold voltage (V_{VBO}) with a hysteresis of V_{HYS} . The VBO circuit will monitor the power supply voltage if the VBO is enabled. When the VBO Reset circuit detects the power supply voltage falls below the threshold voltage V_{VBO} , the VBO resets the device by pulling the POR Reset from 1 to 0. The VBO will hold the POR Reset until the power supply voltage goes above the V_{VBO+} ($V_{VBO} + V_{HYS}$), at which time the VBO Reset is released. The device progresses through a System Reset sequence, as occurred with the POR. Following this System Reset sequence, the POR/VBO status bit in the Reset Status (RSTSTAT) Register is set to 1. [Figure 9](#) on page 43 illustrates this VBO Reset operation.

For VBO threshold voltages (V_{VBO}) and VBO hysteresis (V_{HYS}), see the [Electrical Characteristics](#) chapter on page 601.

The VBO circuit is either enabled or disabled during Stop Mode. If enabled during Stop Mode, the VBO circuit operates only periodically to reduce current consumption. VBO circuit operation is controlled by the VBOCTL Flash option bits; to learn more, see the [Flash Option Bits](#) chapter on page 542. During a POR, the VBO is initially enabled, but is subsequently controlled by VBOCTL upon exit from System Reset.

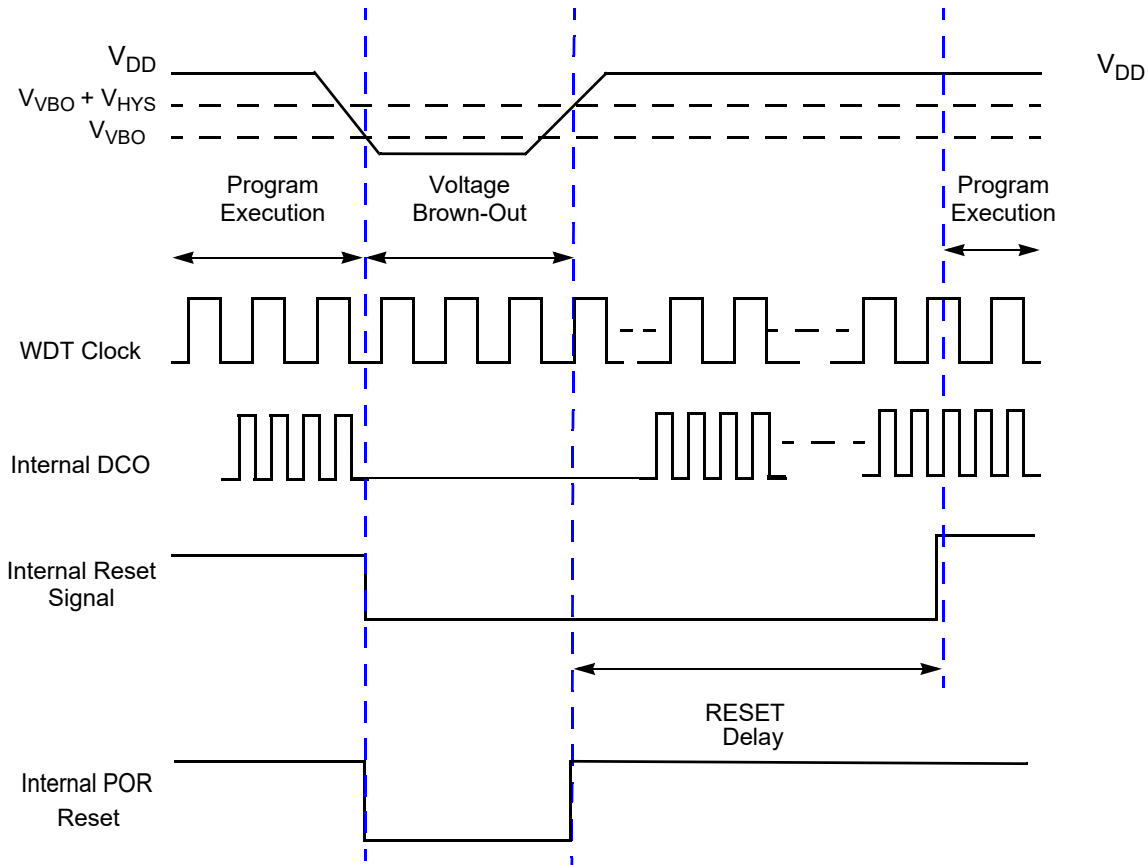

Note: this figure is not to scale.

Figure 9. Voltage Brown-Out Reset Operation

5.2.3. Watchdog Timer Reset

If the device is in Normal or Halt Mode, WDT initiates a System Reset at time-out if the WDT_RES Flash option bit is programmed to 1. This state is the unprogrammed state of the WDT_RES Flash option bit. If the bit is programmed to 0, the WDT is configured to cause an interrupt (WDT_RES = 0 in Flash Option Bits at Program Memory Address 0000h), not a System Reset at time-out. The WDT status bit in the Reset Status Register is set to signify that the reset was initiated by the WDT.

5.2.4. External Reset Input

The $\overline{\text{RESET}}$ pin has a Schmitt-triggered input and an internal pull-up resistor. When the $\overline{\text{RESET}}$ pin is asserted for a minimum of four system clock cycles, the device progresses

through the System Reset sequence. Because of possible asynchronicity of the system clock and reset signals, the required reset duration can be as short as three clock periods and as long as four. A reset pulse three clock cycles in duration could trigger a Reset; a pulse four cycles in duration always triggers a Reset.

While the $\overline{\text{RESET}}$ input pin is asserted Low, the F6482 Series MCU remains in the Reset state. If the $\overline{\text{RESET}}$ pin is held Low beyond the System Reset time-out, the device exits the Reset state on the system clock rising edge following $\overline{\text{RESET}}$ pin deassertion. Following a System Reset initiated by the external $\overline{\text{RESET}}$ pin, the EXT status bit in the RSTSTAT Register is set to 1.

5.2.5. External Reset Indicator

During System Reset, or when enabled by the GPIO logic (see the [Port A–J Control Registers](#) section on page 87), the $\overline{\text{RESET}}$ pin functions as an open-drain (active Low) reset mode indicator in addition to the input functionality. This Reset output feature allows the F6482 Series MCU to reset other components to which it is connected, even if that reset is caused by internal sources such as POR, VBO, or WDT events.

After an internal Reset event occurs, the internal circuitry begins driving the $\overline{\text{RESET}}$ pin Low. The $\overline{\text{RESET}}$ pin is held Low by the internal circuitry until the appropriate delay (listed in [Table 9 on page 39](#)) has elapsed.

5.2.6. On-Chip Debugger Initiated Reset

A POR can be initiated using the OCD by setting the RST bit in the OCD Control Register. The OCD block is not reset, but the remainder of the chip goes through a normal System Reset. The RST bit automatically clears during the system reset. Following the System Reset the POR bit in the Reset Status Register is set.

5.3. Stop-Mode Recovery

Stop Mode is entered by execution of a STOP instruction by the eZ8 CPU. For detailed Stop Mode information, see the [Low-Power Modes](#) section on page 50. Stop-Mode Recovery does not affect on-chip registers other than the Reset Status (RSTSTAT), Clock Control 0 (CLKCTL0), Clock Control 5 (CLKCTL5) and Interrupt Control (IRQCTL) registers.

During Stop-Mode Recovery, the DCO is configured with the most recent DCO delay control code, and is selected as System Clock with the FLL disabled. If the FLL or another system clock source is required, the Stop-Mode Recovery code must reconfigure the Clock System such that the desired system clock source is enabled and selected. To learn more, see the [Clock System](#) chapter on page 96.

► **Note:** After a System Reset or Stop-Mode Recovery, an external crystal oscillator may become unstable. Use software to wait until it is stable before using this crystal as a clock source.

The IPO, LFXO, or external clock drive, when enabled, can be configured to remain operating during Stop Mode (PCKSM = 1 in the CLKCTL1 Register) or to be nonoperating during Stop Mode (PCKSM = 0 in the CLKCTL1 Register). If enabled and configured to be nonoperating during Stop Mode, the clock source will become operational during Stop-Mode Recovery. The FLL is always disabled by entry into Stop Mode and, if required during Normal Operation, must be enabled by software after Stop-Mode Recovery.

Stop-Mode Recovery latency is a function of FRECOV in the Power Control Register 0 (PWRCTL0, see the [Power Control Register Definitions](#) section on page 52). If FRECOV is set, the Stop-Mode Recovery latency is 6 System Clock cycles. If FRECOV is cleared, the Stop-Mode Recovery latency is the Stop-Mode Recovery Delay plus 6 System Clock cycles. To learn more, see Stop-Mode Recovery Delay in the [Electrical Characteristics](#) chapter on page 601.

The eZ8 CPU fetches the Reset vector at Program Memory addresses 0002h and 0003h and loads that value into the Program Counter. Program execution begins at the Reset vector address. Following Stop-Mode Recovery, the STOP bit in the Reset Status Register is set to 1 and the IRQE bit in the IRQCTL Register is cleared disabling interrupts. Software can enable interrupts by setting the IRQE bit or by issuing the EI instruction. Interrupt capable peripherals running in Stop Mode can initiate a Stop-Mode Recovery only if enabled as an interrupt source. Table 11 lists the Stop-Mode Recovery sources and resulting actions. The text following provides more information about each of the Stop-Mode Recovery sources.

Table 11. Stop-Mode Recovery Sources and Resulting Action

Operating Mode	Stop-Mode Recovery Source	Action
Stop Mode	Watchdog Timer time-out when configured for Reset	Stop-Mode Recovery
	Watchdog Timer time-out when configured for interrupt	Stop-Mode Recovery followed by interrupt (if interrupts are reenabled)
	Interrupt from timer enabled for Stop Mode operation	Stop-Mode Recovery followed by interrupt (if interrupts are reenabled)
	Interrupt from comparator enabled for Stop Mode operation	Stop-Mode Recovery followed by interrupt (if interrupts are reenabled)
	Interrupt from RTC enabled for Stop Mode operation	Stop-Mode Recovery followed by interrupt (if interrupts are reenabled)
	Interrupt from LVD enabled for Stop Mode operation	Stop-Mode Recovery followed by interrupt (if interrupts are reenabled)
	Data transition on any GPIO Port pin enabled as a Stop-Mode Recovery source	Stop-Mode Recovery followed by interrupt (if the GPIO was previously enabled as an interrupt source and interrupts are reenabled)
	Assertion of external RESET Pin	System Reset
Debug Pin driven Low	System Reset	

5.3.1. Stop-Mode Recovery Using Watchdog Timer Time-Out

If the WDT times out during Stop Mode, the device undergoes a Stop-Mode Recovery sequence. In the Reset Status Register, the WDT and STOP bits are set to 1. If the WDT is configured to generate an interrupt on time-out and if interrupts are reenabled (IRQE in IRQCTL is set again), the eZ8 CPU services the WDT interrupt request. Reading the RSTSTAT Register resets the WDT bit and clears the WDT interrupt. As a result, the WDT interrupt vector is executed only if interrupts are reenabled prior to reading the RSTSTAT Register. Alternatively, the RSTSTAT Register can be read prior to enabling interrupts followed by a call of the desired WDT interrupt code.

5.3.2. Stop-Mode Recovery Using Timer, Comparator, RTC, or LVD Interrupt

If a timer, comparator, RTC, or LVD enabled for Stop Mode operation asserts during Stop Mode, the device undergoes a Stop-Mode Recovery sequence. Comparator assertion is defined as a high output signal from the Comparator. In the Reset Status Register, the STOP bit is set to 1. If interrupts are reenabled (IRQE in IRQCTL is set again), the eZ8 CPU services the corresponding interrupt request.

5.3.3. Stop-Mode Recovery Using GPIO Port Pin Transition

Many of the GPIO Port pins can be configured as a Stop-Mode Recovery input source. Which GPIO can be configured as a Stop-Mode Recovery input source is described in the [General-Purpose Input/Output](#) chapter on page 55. On any GPIO pin enabled as a Stop-Mode Recovery source, a change in the input pin value (from High to Low or from Low to High) initiates Stop-Mode Recovery. In the Reset Status Register, the STOP bit is set to 1.

If the GPIO is also configured as an interrupt source, an interrupt will occur once interrupts are reenabled.



Caution: In Stop Mode, the GPIO Port Input Data registers (PxIN) are disabled. The Port Input Data registers record the Port transition only if the signal stays on the Port pin until the end of the Stop-Mode Recovery delay. As a result, short pulses on the Port pin can initiate Stop-Mode Recovery without being written to the Port Input Data Register or without initiating an interrupt (if enabled for that pin).

5.3.4. Stop-Mode Recovery Using External $\overline{\text{RESET}}$ Pin

When the F6482 Series MCU is in Stop Mode and the external $\overline{\text{RESET}}$ pin is driven Low, a System Reset occurs. Because of a glitch filter operating on the $\overline{\text{RESET}}$ pin, the Low pulse must be greater than the minimum width specified, or it is ignored. For details, see the [Electrical Characteristics](#) chapter on page 601.

5.4. Low-Voltage Detection

In addition to the VBO Reset described earlier, it is also possible to generate an interrupt when the supply voltage drops below a user-selected value. To learn more about the available Low-Voltage Detection (LVD) threshold levels, see the [Flash Option Bits](#) chapter on page 542.

When the supply voltage drops below the LVD threshold, the LVD bit of the RSTSTAT Register is set to 1. This bit remains 1 until the low-voltage condition elapses. Reading or writing this bit does not clear it. The LVD circuit can also generate an interrupt when enabled; see the [Interrupt Controller](#) chapter on page 127. The LVD is not latched, so enabling the interrupt is the only way to guarantee detection of a transient low-voltage event.

The LVD circuit is either enabled or disabled by the Power Control Register bit 4. To learn more, see the [Power Control Register Definitions](#) section on page 52.

5.5. Reset Register Definitions

The Reset Status (RSTSTAT) Register, shown in Table 12, is a read-only register that indicates the source of the most recent Reset event, Stop-Mode Recovery event and/or WDT time-out. Reading this register resets the upper 4 bits to 0.

Table 13 relates Reset and Stop-Mode recovery events to the Reset Status Register settings.

Table 12. Reset Status Register (RSTSTAT)

Bit	7	6	5	4	3	2	1	0
Field	POR/VBO	STOP	WDT	EXT	Reserved			LVD
Reset	See descriptions below			0	0	0	0	0
R/W	R	R	R	R	R	R	R	R
Address	FF0h							

Bit	Description
[7] POR/VBO	Power-On initiated VBO Reset or general VBO Reset Indicator If this bit is set to 1, a POR or VBO Reset event occurs. This bit is reset to 0, if a WDT time-out or Stop-Mode Recovery occurs. This bit is also reset to 0 when the register is read.
[6] STOP	Stop-Mode Recovery Indicator If this bit is set to 1, a Stop-Mode Recovery occurs. If the STOP and WDT bits are both set to 1, the Stop-Mode Recovery occurs because of a WDT time-out. If the STOP bit is 1 and the WDT bit is 0, the Stop-Mode Recovery is not caused by a WDT time-out. This bit is reset by Power-On Reset or WDT time-out that occurred while not in Stop Mode. Reading this register also resets this bit.
[5] WDT	Watchdog Timer time-out Indicator If this bit is set to 1, a WDT time-out occurs. A POR resets this bit. A Stop-Mode Recovery from a Stop-Mode Recovery source other than the WDT also resets this bit. Reading this register resets this bit. This read must occur to clear the WDT interrupt.
[4] EXT	External Reset Indicator If this bit is set to 1, a Reset initiated by the external $\overline{\text{RESET}}$ pin occurs. A POR or a Stop-Mode Recovery from a change in an input pin resets this bit. Reading this register resets this bit.
[3:1]	Reserved These bits are reserved and must be programmed to 000.
[0] LVD	Low-Voltage Detection Indicator If this bit is set to 1 the current state of the supply voltage is below the low-voltage detection threshold. This value is not latched but is a real-time indicator of the supply voltage level.



Table 13. Reset Status Per Event

Reset or Stop-Mode Recovery Event	POR	STOP	WDT	EXT
Power-On Reset or VBO Reset	1	0	0	0
Reset using RESET pin assertion	0	0	0	1
Reset using Watchdog Timer time-out	0	0	1	0
Reset using the On-Chip Debugger (OCTCTL[1] set to 1)	1	0	0	0
Reset from Stop Mode using DBG Pin driven Low	1	0	0	0
Stop-Mode Recovery using GPIO pin transition	0	1	0	0
Stop-Mode Recovery using Watchdog Timer time-out	0	1	1	0
Stop-Mode Recovery using Timer, RTC, Comparator or Low Voltage Detection interrupt	0	1	0	0

Chapter 6. Low-Power Modes

The F6482 Series products have power-saving features. The highest level of power reduction is provided by the Stop Mode. The next lower level of power reduction is provided by the Halt Mode.

Further power savings can be implemented by disabling individual peripheral blocks while in Normal Mode.

6.1. Stop Mode

Executing the eZ8 CPU's Stop instruction places the device into Stop Mode. In Stop Mode, the operating characteristics are:

- IRQE in the IRQCTL Register is cleared.
- The High Frequency Crystal Oscillator (HFXO) is stopped and the Phase Locked Loop (PLL) is disabled (PLLEN is cleared); X_{IN} and X_{OUT} (if previously enabled) are disabled and PA0/PA1 reverts to the states programmed by the GPIO registers.
- The FLL is disabled (FLEN is cleared) and the DCO is stopped; upon recovering from Stop Mode, the FLL remains disabled and the DCO is enabled, see the [Clock System](#) chapter on page 96 to learn more.
- If enabled and selected as the Peripheral Clock (PCKSEL in the Clock Control 1 Register), a PCLK source can be configured to operate in Stop Mode, as follows:
 - Internal Precision Oscillator (IPO): PCKSM = 1 in the Clock Control 1 Register and FRECOV = 1 in the Power Control 0 Register
 - Low Frequency Crystal Oscillator (LFXO): PCKSM = 1 in the Clock Control 1 Register
 - External clock drive: PCKSM = 1 in the Clock Control 1 Register
- If enabled, the RTC continues to operate with the selected RTC clock source.
- System Clock is stopped.
- eZ8 CPU is stopped.
- Program counter (PC) stops incrementing.
- If enabled, the Watchdog Timer (WDT) logic continues operating.
- If enabled for operation in Stop Mode, the Timer logic continues to operate with the selected Timer clock source.

- If enabled for operation in Stop Mode by the associated Flash option bits, the VBO protection circuit continues operating; the LVD circuit continues to operate if enabled by the Power Control Register 0.
- Operational Amplifiers, comparators, and Temperature Sensor continue to operate if both enabled by the Power Control Register 0 and FRECOV=1.
- LCD continue to operate if enabled by the Power Control Register 0.
- All other on-chip peripherals are idle.

To minimize current in Stop Mode, all GPIO pins which are configured as digital inputs must be driven to one of the supply rails (V_{DD} or GND). The device is brought out of Stop Mode using Stop-Mode Recovery. To learn more about Stop-Mode Recovery, see the [Reset, Stop-Mode Recovery and Low-Voltage Detection](#) chapter on page 38.

6.2. Halt Mode

Executing the eZ8 CPU's Halt instruction places the device into Halt Mode. In Halt Mode, the operating characteristics are:

- Any enabled crystal oscillator continues to operate
- System clock is enabled and continues to operate
- eZ8 CPU is stopped
- Program counter (PC) stops incrementing
- If enabled, the WDT continues to operate
- All other on-chip peripherals continue to operate

The eZ8 CPU can be brought out of Halt Mode by any of the following operations:

- Interrupt
- Watchdog Timer time-out (Interrupt or Reset)
- Power-On Reset
- Voltage Brown-Out Reset
- External $\overline{\text{RESET}}$ pin assertion

To minimize current in Halt Mode, all GPIO pins which are configured as inputs must be driven to one of the supply rails (V_{DD} or GND).

6.3. Peripheral-Level Power Control

In addition to the Stop and Halt modes, it is possible to disable each peripheral on each of the F6482 Series devices. Disabling a given peripheral minimizes its power consumption.

6.4. Power Control Register Definitions

Each bit of the following registers disables a peripheral block, either by gating its system clock input or by removing power from the block.

With the exception of the LVD, the default state of all peripherals is OFF. To use a peripheral, set the peripheral's enable bit. If a peripheral is not offered on a particular product, setting or clearing the corresponding disable bit has no effect on product operation. Some enabled peripherals even run in Stop Mode. If the peripheral is not required in Stop Mode, disable it. Failure to perform this task results in Stop Mode currents greater than specified.

► **Note:** This register is only reset during a POR/VBO Reset; other System Reset events do not affect this register.

6.4.1. Power Control Register 0

Table 14. Power Control Register 0 (PWRCTL0)

Bit	7	6	5	4	3	2	1	0
Field	OpAmpB	OpAmpA	LCD	LVD	TEMP	FRECOV	COMP0	COMP1
Reset	0	0	0	1	0	0	0	0
R/W	R/W	R/W	R/W	R/W	R/W	R/W	R/W	R/W
Address	F80h							

Bit	Description
[7] OpAmpB	Op Amp B Enable 0=Op Amp B is disabled. 1=Op Amp B is enabled (this applies even in Stop Mode if FRECOV=1).
[6] OpAmpA	Op Amp A Enable 0=Op Amp A is disabled. 1=Op Amp A is enabled (this applies even in Stop Mode if FRECOV=1).
[5] LCD	LCD Enable 0=LCD is disabled. 1=LCD is enabled (this applies even in Stop Mode).

Bit	Description (Continued)
[4] LVD	Low-Voltage Detection Enable 0=LVD disabled. 1=LVD enabled (this applies even in Stop Mode).
[3] TEMP	Temperature Sensor Enable 0=Temperature Sensor disabled. 1=Temperature Sensor enabled (this applies even in Stop Mode if FRECOV=1).
[2] FRECOV	Fast Recovery 0=Fast Recovery disabled. 1=Fast Recovery enabled. Fast Recovery provides for the shortest Stop-Mode recovery latency at the expense of higher Stop Mode current consumption. See the Reset, Stop-Mode Recovery and Low-Voltage Detection chapter on page 38 to learn more. In addition, this bit must be set for certain peripherals to remain active during Stop Mode as described in this chapter.
[1] COMP0	Comparator 0 Enable 0=Comparator 0 is disabled. 1=Comparator 0 is enabled (this applies even in Stop Mode if FRECOV=1).
[0] COMP1	Comparator 1 Enable 0=Comparator 1 is disabled). 1=Comparator 1 is enabled (this applies even in Stop Mode if FRECOV=1).

6.4.2. Power Control Register 1

Table 15. Power Control Register 1 (PWRCTL1)

Bit	7	6	5	4	3	2	1	0
Field	Reserved				ADC		DAC	Reserved
Reset	0	0	0	0	0	0	0	0
R/W	R/W	R/W	R/W	R/W	R/W	R/W	R/W	R/W
Address	F81h							

Bit	Description
[7:4]	Reserved This bit is reserved and must be programmed to 0.
[3:2] ADC	ADC and ADC Internal Voltage Reference Buffer Continuous Enable 00: ADC is auto enabled when a conversion is triggered. The ADC wake up time, T_{WAKE_ADC} , is incurred prior to the conversion starting. 01: Reserved. 10: Reserved. 11: The ADC is continuously enabled (while in Normal or Halt modes). Additionally, if selected as the ADC positive reference, the ADC internal voltage reference buffer is continuously enabled (while in Normal or Halt modes). This selection is typically used when the ADC internal voltage reference buffer is connected to the V_{REF+} pin (REFSEL = 11 in the ADCCTL2 Register). The ADC wake up time, T_{WAKE_ADC} , is overridden to be zero.
[1] DAC	DAC Enable 0: DAC is disabled. 1: DAC is enabled.
[0]	Reserved This bit is reserved and must be programmed to 0.

Chapter 7. General-Purpose Input/Output

The F6482 Series products support a maximum of 67 port pins (ports A–J) for general-purpose input/output (GPIO) operations. Each port contains control and data registers. The GPIO control registers determine data direction, open-drain, output drive current, programmable pull-ups, Stop-Mode Recovery functionality, and alternate pin functions. Each port pin is individually programmable.

7.1. GPIO Port Availability by Device

Table 16 lists the port pins available with each device and package type.

Table 16. Port Availability by Device and Package Type

Device	Pkg.	12-Bit						Port										Total I/O
		ADC	I ² C	LCD	SPI	UART	USB	A	B	C	D	E	F	G	H	J		
Z8F6481QK, Z8F6081QK, Z8F3281QK, Z8F1681QK	32-pin QFN	9	1	–	1	1	1	[7:0]	[6:0]	[7:0]	[0]	[1:0]	–	–	–	–	26	
Z8F6481AN, Z8F6081AN, Z8F3281AN, Z8F1681AN	44-pin LQFP	10	1	–	1	2	1	[7:0]	[4:0]	[7:0]	[7:0]	[6:0]	–	–	–	–	36	
Z8F6481QN, Z8F6081QN, Z8F3281QN, Z8F1681QN	44-pin QFN	10	1	–	1	2	1	[7:0]	[4:0]	[7:0]	[7:0]	[6:0]	–	–	–	–	36	
Z8F6481AR, Z8F6081AR, Z8F3281AR, Z8F1681AR	64-pin LQFP	12	1	–	2	2	1	[7:0]	[7:0]	[7:0]	[7:0]	[6:0]	[7:0]	[4:0]	–	–	52	
Z8F6482AR, Z8F6082AR, Z8F3282AR, Z8F1682AR	64-pin LQFP	8	1	1	2	1	0	[7:0]	[5:0]	[7:0]	[0]	–	[7:0]	[7:0]	[7:0]	[3:0]	51	
Z8F6482AT, Z8F6082AT, Z8F3282AT, Z8F1682AT	80-pin LQFP	12	1	1	2	2	1	[7:0]	[7:0]	[7:0]	[7:0]	[6:0]	[7:0]	[7:0]	[7:0]	[3:0]	67	

7.2. Architecture

Figure 10 shows a simplified block diagram of a GPIO port pin and does not illustrate the ability to accommodate alternate functions and variable port current drive strength.

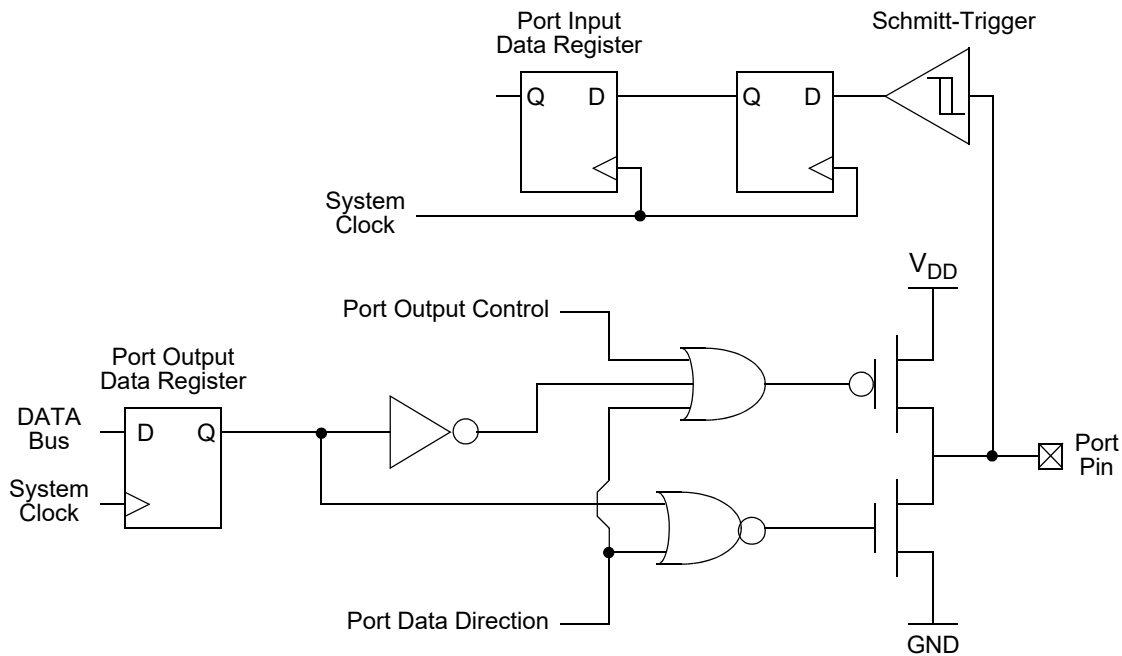

Figure 10. GPIO Port Pin Block Diagram

7.3. GPIO Alternate Functions

Many GPIO port pins are used for GPIO and to access the on-chip peripheral functions like the timers and serial-communication devices. The Port A–J Alternate Function subregisters configure these pins for either GPIO or alternate function operation. When a pin is configured for alternate function, control of port-pin direction (input/output) is passed from Port A–J Data Direction subregisters to the alternate functions assigned to this pin. When the alternate function is an analog function such as ANAx, the control of pull-up enable is also passed from the Port A–J Pull-Up Enable subregister to the alternate functions assigned to this pin. [Tables 17 through 21](#), beginning on page 58, list the alternate functions possible with each port pin for every package. The alternate function associated at a pin is defined through alternate function sets subregisters AFS1 and AFS2. $\overline{T0OUT}$, $\overline{T1OUT}$, and $\overline{T2OUT}$ are output only when the corresponding Timer is in PWM Dual Output Mode.

The crystal oscillator and the 32kHz secondary oscillator functionalities are not controlled by the GPIO block. When the crystal oscillator or the 32kHz secondary oscillator is enabled in the clock system block, the GPIO functionality of PA0 and PA1, or PA2 and PA3, is overridden. In such a case, those pins function as input and output for the crystal oscillator.

7.4. Shared Reset Pin

On all devices, the Port D0 pin shares a function with a bidirectional reset pin. Unlike all other I/O pins, this pin does not default to GPIO pin on power-up. This pin acts as a bidirectional, open-drain reset with pull-up until user software reconfigures it. The Port D0 pin is output-only when in GPIO Mode and does not function as a Stop-Mode Recovery source.

7.5. High Frequency Crystal Oscillator Override

For systems using the High Frequency Crystal Oscillator (HFXO), PA0 and PA1 are used to connect the crystal. When the HFXO is enabled, the GPIO settings are overridden and PA0 and PA1 is disabled; see the [Clock Control 2 Register \(CLKCTL2\)](#) on page 117.

7.6. Low Frequency Crystal Oscillator Override

For systems using the Low Frequency Crystal Oscillator (LFXO), PA2 and PA3 are used to connect a watch crystal. When the LFXO is enabled, the GPIO settings are overridden and PA2 and PA3 is disabled; see the [Clock Control 1 Register \(CLKCTL1\)](#) on page 116.

7.7. External Clock Setup

For systems using an external TTL drive, PA0 is the clock source for the PLL and the system clock selection multiplexer, and PA2 is the clock source for PCLK. For systems using an external clock drive of the PLL and a system clock source multiplexer, configure PA0 for alternate function CLKIN and write to the [Clock Control C Register \(CLKCTLC\)](#) (see Table 50 on page 126) to select the External Clock Drive. For systems using an external clock drive for PCLK, configure PA2 for alternate function CLK2IN and write the [Clock Control 1 Register](#) (see page 116) to select the External Clock Drive.

7.8. Port Alternate Function Mapping

Alternate Function subregisters enable the alternate function selection on pins. [Tables 17 through 21](#) indicate the port alternate function mapping.

Table 17. Port Alternate Function Mapping, 32-Pin Parts

Port	Pin	Mnemonic	Alternate Function Description	Alternate Function Set Subregisters
Port A ¹	PA0	T0IN/T0OUT	Timer 0 Input/Timer 0 Output Complement	AFS1[0]: 0
		CLKIN	External Clock Input	AFS1[0]: 1
PA1		T0OUT	Timer 0 Output	AFS1[1]: 0
		Reserved		AFS1[1]: 1
PA2		DE0	UART 0 Driver Enable	AFS1[2]: 0
		CLK2IN	External Clock2 Input	AFS1[2]: 1
PA3		CTS0	UART 0 Clear to Send	AFS1[3]: 0
		Reserved		AFS1[3]: 1
PA4		RXD0/	UART 0 Receive Data	AFS1[4]: 0
		MOSI0	SPI 0 Master Out/Slave In	AFS1[4]: 1
PA5		TXD0/	UART 0 Transmit Data	AFS1[5]: 0
		SCK0	SPI 0 Serial Clock	AFS1[5]: 1
PA6		T1IN/T1OUT	Timer 1 Input/Timer 1 Output Complement	AFS1[6]: 0
		SCL	I ² C Serial Clock	AFS1[6]: 1
PA7		T1OUT	Timer 1 Output	AFS1[7]: 0
		SDA	I ² C Serial Data	AFS1[7]: 1

Notes

1. Because there are at most two choices of alternate function for some pins of Ports A, B, D and E, the Alternate Function Set Subregister AFS2 is not implemented. Additionally, alternate function selection, as described in the Port A–J Alternate Function Subregisters ([see page 88](#)), must also be enabled.
2. The alternate function selection for Port C, as described in the Port A–J Alternate Function Subregisters ([see page 88](#)), must also be enabled.

Table 17. Port Alternate Function Mapping, 32-Pin Parts (Continued)

Port	Pin	Mnemonic	Alternate Function Description	Alternate Function Set Subregisters
Port B ¹	PB0	Reserved		AFS1[0]: 0
		ANA0/AMPAOUT	ADC Analog Input/Op Amp A Output	AFS1[0]: 1
	PB1	Reserved		AFS1[1]: 0
		ANA1/AMPAINN	ADC Analog Input/Op Amp A Input (N)	AFS1[1]: 1
	PB2	Reserved		AFS1[2]: 0
		ANA2/AMPAINP	ADC Analog Input/Op Amp A Input (P)	AFS1[2]: 1
	PB3	Reserved		AFS1[3]: 0
		V _{REF-}	Voltage Reference (M)	AFS1[3]: 1
	PB4	Reserved		AFS1[4]: 0
		V _{REF+}	Voltage Reference (P)	AFS1[4]: 1
	PB5	Reserved		AFS1[5]: 0
		ANA9	ADC Analog Input	AFS1[5]: 1
	PB6	Reserved		AFS1[6]: 0
		ANA10	ADC Analog Input	AFS1[6]: 1

Notes

1. Because there are at most two choices of alternate function for some pins of Ports A, B, D and E, the Alternate Function Set Subregister AFS2 is not implemented. Additionally, alternate function selection, as described in the Port A–J Alternate Function Subregisters ([see page 88](#)), must also be enabled.
2. The alternate function selection for Port C, as described in the Port A–J Alternate Function Subregisters ([see page 88](#)), must also be enabled.

Table 17. Port Alternate Function Mapping, 32-Pin Parts (Continued)

Port	Pin	Mnemonic	Alternate Function Description	Alternate Function Set Subregisters
Port C ²	PC0	Reserved		AFS1[0]: 0, AFS2[0]: 0
		ANA4/VBIAS/C0INP	ADC or Voltage Bias with low current drive capability or Comparator 0 Input (P)	AFS1[0]: 1, AFS2[0]: 0
		Reserved		AFS1[0]: x, AFS2[0]: 1
PC1	PC1	MISO0	SPI 0 Master In/Slave Out	AFS1[1]: 0, AFS2[1]: 0
		ANA5/C0INN	ADC or Comparator 0 Input (N)	AFS1[1]: 1, AFS2[1]: 0
		Reserved		AFS1[1]: x, AFS2[1]: 1
PC2	PC2	SS0	SPI 0 Slave Select	AFS1[2]: 0, AFS2[2]: 0
		ANA3	ADC Analog Input	AFS1[2]: 1, AFS2[2]: 0
		Reserved		AFS1[2]: x, AFS2[2]: 1
PC3	PC3	MISO0	SPI 0 Master In/Slave Out	AFS1[3]: 0, AFS2[3]: 0
		ANA11/DAC	ADC or DAC	AFS1[3]: 1, AFS2[3]: 0
		C0OUT	Comparator 0 Output	AFS1[3]: 0, AFS2[3]: 1
		Reserved		AFS1[3]: 1, AFS2[3]: 1
PC4	PC4	MOSI0	SPI 0 Master Out/Slave In	AFS1[4]: 0, AFS2[4]: 0
		T0IN/T0OUT	Timer 0 Input/Timer 0 Output Complement	AFS1[4]: 1, AFS2[4]: 0
		SCL	I ² C Serial Clock	AFS1[4]: 0, AFS2[4]: 1
		DE0	UART 0 Driver Enable	AFS1[4]: 1, AFS2[4]: 1
PC5	PC5	SCK0	SPI 0 Serial Clock	AFS1[5]: 0, AFS2[5]: 0
		T0OUT	Timer 0 Output	AFS1[5]: 1, AFS2[5]: 0
		SDA	I ² C Serial Data	AFS1[5]: 0, AFS2[5]: 1
		CTS0	UART 0 Clear to Send	AFS1[5]: 1, AFS2[5]: 1
PC6	PC6	T2IN/T2OUT	Timer 2 Input/Timer 2 Output Complement	AFS1[6]: 0, AFS2[6]: 0
		SCKOUT	System Clock Out	AFS1[6]: 1, AFS2[6]: 0
		ESOUT[0]	Event System Output 0	AFS1[6]: 0, AFS2[6]: 1
		Reserved		AFS1[6]: 1, AFS2[6]: 1

Notes

1. Because there are at most two choices of alternate function for some pins of Ports A, B, D and E, the Alternate Function Set Subregister AFS2 is not implemented. Additionally, alternate function selection, as described in the Port A–J Alternate Function Subregisters ([see page 88](#)), must also be enabled.
2. The alternate function selection for Port C, as described in the Port A–J Alternate Function Subregisters ([see page 88](#)), must also be enabled.

Table 17. Port Alternate Function Mapping, 32-Pin Parts (Continued)

Port	Pin	Mnemonic	Alternate Function Description	Alternate Function Set Subregisters
Port C ² (cont'd.)	PC7	T2OUT	Timer 2 Output	AFS1[7]: 0, AFS2[7]: 0
		Reserved		AFS1[7]: 1, AFS2[7]: 0
		ESOUT[1]	Event System Output 1	AFS1[7]: 0, AFS2[7]: 1
		Reserved		AFS1[7]: 1, AFS2[7]: 1
Port D ¹	PD0	RESET	External Reset	AFS1[0]: 0
		Reserved		AFS1[0]: 1
Port E ¹	PE0	DP	USB DP	AFS1[0]: 0
		T0IN/T0OUT	Timer 0 Input/Timer 0 Output Complement	AFS1[0]: 1
	PE1	DM	USB DM	AFS1[1]: 0
		T0OUT	Timer 0 Output	AFS1[1]: 1

Notes

1. Because there are at most two choices of alternate function for some pins of Ports A, B, D and E, the Alternate Function Set Subregister AFS2 is not implemented. Additionally, alternate function selection, as described in the Port A–J Alternate Function Subregisters ([see page 88](#)), must also be enabled.
2. The alternate function selection for Port C, as described in the Port A–J Alternate Function Subregisters ([see page 88](#)), must also be enabled.

Table 18. Port Alternate Function Mapping (44-Pin Parts)

Port	Pin	Mnemonic	Alternate Function Description	Alternate Function Set Subregisters
Port A ¹	PA0	T0IN/T0OUT	Timer 0 Input/Timer 0 Output Complement	AFS1[0]: 0
		CLKIN	External Clock Input	AFS1[0]: 1
	PA1	T0OUT	Timer 0 Output	AFS1[1]: 0
		Reserved		AFS1[1]: 1
	PA2	DE0	UART 0 Driver Enable	AFS1[2]: 0
		CLK2IN	External Clock 2 Input	AFS1[2]: 1
	PA3	CTS0	UART 0 Clear to Send	AFS1[3]: 0
		Reserved		AFS1[3]: 1
	PA4	RXD0/	UART 0 Receive Data	AFS1[4]: 0
		MOSI0	SPI 0 Master Out/Slave In	AFS1[4]: 1
	PA5	TXD0/	UART 0 Transmit Data	AFS1[5]: 0
		SCK0	SPI 0 Serial Clock	AFS1[5]: 1
	PA6	T1IN/T1OUT	Timer 1 Input/Timer 1 Output Complement	AFS1[6]: 0
		SCL	I ² C Serial Clock	AFS1[6]: 1
PA7	T1OUT	Timer 1 Output	AFS1[7]: 0	
	SDA	I ² C Serial Data	AFS1[7]: 1	
Port B ¹	PB0	Reserved		AFS1[0]: 0
		ANA0/AMPAOUT	ADC Analog Input/OpAmp A Output	AFS1[0]: 1
	PB1	Reserved		AFS1[1]: 0
		ANA1/AMPAINN	ADC Analog Input/OpAmp A Input (N)	AFS1[1]: 1
	PB2	Reserved		AFS1[2]: 0
		ANA2/AMPAINP	ADC Analog Input/OpAmp A Input (P)	AFS1[2]: 1
	PB3	Reserved		AFS1[3]: 0
		V _{REF} ⁻	Voltage Reference (M)	AFS1[3]: 1
	PB4	Reserved		AFS1[4]: 0
		V _{REF} ⁺	Voltage Reference (P)	AFS1[4]: 1

Notes

1. Because there are at most two choices of alternate function for some pins of Ports A, B, D and E, the Alternate Function Set register AFS2 is not implemented. Additionally, alternate function selection, as described in the Port A–J Alternate Function Subregisters ([see page 88](#)), must also be enabled.
2. The alternate function selection for Port C, as described in the Port A–J Alternate Function Subregisters ([see page 88](#)), must also be enabled.

Table 18. Port Alternate Function Mapping (44-Pin Parts) (Continued)

Port	Pin	Mnemonic	Alternate Function Description	Alternate Function Set Subregisters
Port C ²	PC0	Reserved		AFS1[0]: 0, AFS2[0]: 0
		ANA4/VBIAS/C0INP	ADC or Voltage Bias with low current drive capability or Comparator 0 Input (P)	AFS1[0]: 1, AFS2[0]: 0
		Reserved		AFS1[0]: x, AFS2[0]: 1
PC1	PC1	MISO0	SPI 0 Master In/Slave Out	AFS1[1]: 0, AFS2[1]: 0
		ANA5/C0INN	ADC or Comparator 0 Input (N)	AFS1[1]: 1, AFS2[1]: 0
		Reserved		AFS1[1]: x, AFS2[1]: 1
PC2	PC2	SS0	SPI 0 Slave Select	AFS1[2]: 0, AFS2[2]: 0
		ANA3	ADC Analog Input	AFS1[2]: 1, AFS2[2]: 0
		Reserved		AFS1[2]: x, AFS2[2]: 1
PC3	PC3	MISO0	SPI 0 Master In Slave Out	AFS1[3]: 0, AFS2[3]: 0
		ANA11/DAC	ADC or DAC	AFS1[3]: 1, AFS2[3]: 0
		Reserved		AFS1[3]: x, AFS2[3]: 1
PC4	PC4	MOSI0	SPI 0 Master Out/Slave In	AFS1[4]: 0, AFS2[4]: 0
		T0IN/T0OUT	Timer 0 Input/Timer 0 Output Complement	AFS1[4]: 1, AFS2[4]: 0
		SCL	I ² C Serial Clock	AFS1[4]: 0, AFS2[4]: 1
		DE0	UART 0 Driver Enable	AFS1[4]: 1, AFS2[4]: 1
PC5	PC5	SCK0	SPI 0 Serial Clock	AFS1[5]: 0, AFS2[5]: 0
		T0OUT	Timer 0 Output	AFS1[5]: 1, AFS2[5]: 0
		SDA	I ² C Serial Data	AFS1[5]: 0, AFS2[5]: 1
		CTS0	UART 0 Clear to Send	AFS1[5]: 1, AFS2[5]: 1

Notes

1. Because there are at most two choices of alternate function for some pins of Ports A, B, D and E, the Alternate Function Set register AFS2 is not implemented. Additionally, alternate function selection, as described in the Port A–J Alternate Function Subregisters ([see page 88](#)), must also be enabled.
2. The alternate function selection for Port C, as described in the Port A–J Alternate Function Subregisters ([see page 88](#)), must also be enabled.

Table 18. Port Alternate Function Mapping (44-Pin Parts) (Continued)

Port	Pin	Mnemonic	Alternate Function Description	Alternate Function Set Subregisters
Port C ² (cont'd.)	PC6	T2IN/T2OUT	Timer 2 Input/Timer2 Output Complement	AFS1[6]: 0, AFS2[6]: 0
		SCKOUT	System Clock Out	AFS1[6]: 1, AFS2[6]: 0
		ESOUT[0]	Event System Output 0	AFS1[6]: 0, AFS2[6]: 1
		Reserved		AFS1[6]: 1, AFS2[6]: 1
	PC7	T2OUT	Timer 2 Output	AFS1[7]: 0, AFS2[7]: 0
		CTS1	UART 1 Clear to Send	AFS1[7]: 1, AFS2[7]: 0
		ESOUT[1]	Event System Output 1	AFS1[7]: 0, AFS2[7]: 1
		Reserved		AFS1[7]: 1, AFS2[7]: 1
Port D ¹	PD0	RESET	External Reset	AFS1[0]: 0
		Reserved		AFS1[0]: 1
	PD1	C1INN	Comparator 1 Input (N)	AFS1[1]: 0
		ANA7/AMPBINN	ADC Analog Input/OpAmp B Input (N)	AFS1[1]: 1
	PD2	C1INP	Comparator 1 Input (P)	AFS1[2]: 0
		ANA6/AMPBINP	ADC Analog Input/OpAmp B Input (P)	AFS1[2]: 1
	PD3	C1OUT	Comparator 1 Output	AFS1[3]: 0
		ANA8/AMPBOUT	ADC Analog Input/OpAmp B Output	AFS1[3]: 1
	PD4	RXD1	UART 1 Receive Data	AFS1[4]: 0
		Reserved		AFS1[4]: 1
	PD5	TXD1	UART 1 Transmit Data	AFS1[5]: 0
		Reserved		AFS1[5]: 1
	PD6	DE1	UART 1 Driver Enable	AFS1[6]: 0
		Reserved		AFS1[6]: 1
	PD7	C0OUT	Comparator 0 Output	AFS1[7]: 0
		Reserved		AFS1[7]: 1

Notes

1. Because there are at most two choices of alternate function for some pins of Ports A, B, D and E, the Alternate Function Set register AFS2 is not implemented. Additionally, alternate function selection, as described in the Port A–J Alternate Function Subregisters ([see page 88](#)), must also be enabled.
2. The alternate function selection for Port C, as described in the Port A–J Alternate Function Subregisters ([see page 88](#)), must also be enabled.

Table 18. Port Alternate Function Mapping (44-Pin Parts) (Continued)

Port	Pin	Mnemonic	Alternate Function Description	Alternate Function Set Subregisters
Port E ¹	PE0	DP	USB DP	AFS1[0]: 0
		T0IN/T0OUT	Timer 0 Input/Timer 0 Output Complement	AFS1[0]: 1
PE1	PE1	DM	USB DM	AFS1[1]: 0
		T0OUT	Timer 0 Output	AFS1[1]: 1
PE2	PE2	T4IN	Multi Channel Timer Input	AFS1[2]: 0
		Reserved		AFS1[2]: 1
PE3	PE3	T4CHA	Multi Channel Timer Input/Output A	AFS1[3]: 0
		ESOUT[0]	Event System Out 0	AFS1[3]: 1
PE4	PE4	T4CHB	Multi Channel Timer Input/Output B	AFS1[4]: 0
		ESOUT[1]	Event System Out 1	AFS1[4]: 1
PE5	PE5	T4CHC	Multi Channel Timer Input/Output C	AFS1[5]: 0
		ESOUT[2]	Event System Out 2	AFS1[5]: 1
PE6	PE6	T4CHD	Multi Channel Timer Input/Output D	AFS1[6]: 0
		ESOUT[3]	Event System Out 3	AFS1[6]: 1

Notes

1. Because there are at most two choices of alternate function for some pins of Ports A, B, D and E, the Alternate Function Set register AFS2 is not implemented. Additionally, alternate function selection, as described in the Port A–J Alternate Function Subregisters ([see page 88](#)), must also be enabled.
2. The alternate function selection for Port C, as described in the Port A–J Alternate Function Subregisters ([see page 88](#)), must also be enabled.

Table 19. Port Alternate Function Mapping (Z8Fxx81 64-Pin Parts)

Port	Pin	Mnemonic	Alternate Function Description	Alternate Function Set Subregisters
Port A ¹	PA0	T0IN/T0OUT	Timer 0 Input/Timer 0 Output Complement	AFS1[0]: 0
		CLKIN	External Clock Input	AFS1[0]: 1
	PA1	T0OUT	Timer 0 Output	AFS1[1]: 0
		Reserved		AFS1[1]: 1
	PA2	DE0	UART 0 Driver Enable	AFS1[2]: 0
		CLK2IN	External Clock 2 Input	AFS1[2]: 1
	PA3	CTS0	UART 0 Clear to Send	AFS1[3]: 0
		Reserved		AFS1[3]: 1
	PA4	RXD0/	UART 0 Receive Data	AFS1[4]: 0
		MOSI0	SPI 0 Master Out/Slave In	AFS1[4]: 1
	PA5	TXD0/	UART 0 Transmit Data	AFS1[5]: 0
		SCK0	SPI 0 Serial Clock	AFS1[5]: 1
	PA6	T1IN/T1OUT	Timer 1 Input/Timer 1 Output Complement	AFS1[6]: 0
		SCL	I ² C Serial Clock	AFS1[6]: 1
PA7	T1OUT	Timer 1 Output	AFS1[7]: 0	
	SDA	I ² C Serial Data	AFS1[7]: 1	

Notes

1. Because there are at most two choices of alternate function for some pins of Ports A, B, D, E and F, the Alternate Function Set register AFS2 is not implemented. Additionally, alternate function selection, as described in the Port A–J Alternate Function Subregisters ([see page 88](#)), must also be enabled.
2. The alternate function selection for Port C, as described in the Port A–J Alternate Function Subregisters ([see page 88](#)), must also be enabled.

Table 19. Port Alternate Function Mapping (Z8Fxx81 64-Pin Parts) (Continued)

Port	Pin	Mnemonic	Alternate Function Description	Alternate Function Set Subregisters
Port B ¹	PB0	Reserved		AFS1[0]: 0
		ANA0/AMPAOUT	ADC Analog Input/OpAmp A Output	AFS1[0]: 1
PB1	PB1	Reserved		AFS1[1]: 0
		ANA1/AMPAINN	ADC Analog Input/OpAmp A Input (N)	AFS1[1]: 1
PB2	PB2	Reserved		AFS1[2]: 0
		ANA2/AMPAINP	ADC Analog Input/OpAmp A Input (P)	AFS1[2]: 1
PB3	PB3	Reserved		AFS1[3]: 0
		V _{REF-}	Voltage Reference (M)	AFS1[3]: 1
PB4	PB4	Reserved		AFS1[4]: 0
		V _{REF+}	Voltage Reference (P)	AFS1[4]: 1
PB5	PB5	Reserved		AFS1[5]: 0
		ANA9	ADC Analog Input	AFS1[5]: 1
PB6	PB6	Reserved		AFS1[6]: 0
		ANA10	ADC Analog Input	AFS1[6]: 1
PB7	PB7	Reserved		AFS1[7]: 0
		Reserved		AFS1[7]: 1

Notes

1. Because there are at most two choices of alternate function for some pins of Ports A, B, D, E and F, the Alternate Function Set register AFS2 is not implemented. Additionally, alternate function selection, as described in the Port A–J Alternate Function Subregisters ([see page 88](#)), must also be enabled.
2. The alternate function selection for Port C, as described in the Port A–J Alternate Function Subregisters ([see page 88](#)), must also be enabled.

Table 19. Port Alternate Function Mapping (Z8Fxx81 64-Pin Parts) (Continued)

Port	Pin	Mnemonic	Alternate Function Description	Alternate Function Set Subregisters
Port C ²	PC0	Reserved		AFS1[0]: 0, AFS2[0]: 0
		ANA4/VBIAS/C0INP	ADC or Voltage Bias with low current drive capability or Comparator 0 Input (P)	AFS1[0]: 1, AFS2[0]: 0
		Reserved		AFS1[0]: x, AFS2[0]: 1
PC1	PC1	MISO0	SPI 0 Master In/Slave Out	AFS1[1]: 0, AFS2[1]: 0
		ANA5/C0INN	ADC or Comparator 0 Input (N)	AFS1[1]: 1, AFS2[1]: 0
		Reserved		AFS1[1]: x, AFS2[1]: 1
PC2	PC2	SS0	SPI 0 Slave Select	AFS1[2]: 0, AFS2[2]: 0
		ANA3	ADC Analog Input	AFS1[2]: 1, AFS2[2]: 0
		Reserved		AFS1[2]: x, AFS2[2]: 1
PC3	PC3	MISO0	SPI 0 Master In Slave Out	AFS1[3]: 0, AFS2[3]: 0
		ANA11/DAC	ADC or DAC	AFS1[3]: 1, AFS2[3]: 0
		Reserved		AFS1[3]: x, AFS2[3]: 1
PC4	PC4	MOSI0	SPI 0 Master Out/Slave In	AFS1[4]: 0, AFS2[4]: 0
		T0IN/T0OUT	Timer 0 Input/Timer 0 Output Complement	AFS1[4]: 1, AFS2[4]: 0
		SCL	I ² C Serial Clock	AFS1[4]: 0, AFS2[4]: 1
		DE0	UART 0 Driver Enable	AFS1[4]: 1, AFS2[4]: 1
PC5	PC5	SCK0	SPI 0 Serial Clock	AFS1[5]: 0, AFS2[5]: 0
		T0OUT	Timer 0 Output	AFS1[5]: 1, AFS2[5]: 0
		SDA	I ² C Serial Data	AFS1[5]: 0, AFS2[5]: 1
		CTS0	UART 0 Clear to Send	AFS1[5]: 1, AFS2[5]: 1

Notes

1. Because there are at most two choices of alternate function for some pins of Ports A, B, D, E and F, the Alternate Function Set register AFS2 is not implemented. Additionally, alternate function selection, as described in the Port A–J Alternate Function Subregisters ([see page 88](#)), must also be enabled.
2. The alternate function selection for Port C, as described in the Port A–J Alternate Function Subregisters ([see page 88](#)), must also be enabled.

Table 19. Port Alternate Function Mapping (Z8Fxx81 64-Pin Parts) (Continued)

Port	Pin	Mnemonic	Alternate Function Description	Alternate Function Set Subregisters
Port C ² (cont'd.)	PC6	T2IN/T2OUT	Timer 2 Input/Timer2 Output Complement	AFS1[6]: 0, AFS2[6]: 0
		SCKOUT	System Clock Out	AFS1[6]: 1, AFS2[6]: 0
		ESOUT[0]	Event System Output 0	AFS1[6]: 0, AFS2[6]: 1
		Reserved		AFS1[6]: 1, AFS2[6]: 1
	PC7	T2OUT	Timer 2 Output	AFS1[7]: 0, AFS2[7]: 0
		CTS1	UART 1 Clear to Send	AFS1[7]: 1, AFS2[7]: 0
		ESOUT[1]	Event System Output 1	AFS1[7]: 0, AFS2[7]: 1
		Reserved		AFS1[7]: 1, AFS2[7]: 1
Port D ¹	PD0	RESET	External Reset	AFS1[0]: 0
		Reserved		AFS1[0]: 1
	PD1	C1INN	Comparator 1 Input (N)	AFS1[1]: 0
		ANA7/AMPBINN	ADC Analog Input/OpAmp B Input (N)	AFS1[1]: 1
	PD2	C1INP	Comparator 1 Input (P)	AFS1[2]: 0
		ANA6/AMPBINP	ADC Analog Input/OpAmp B Input (P)	AFS1[2]: 1
	PD3	C1OUT	Comparator 1 Output	AFS1[3]: 0
		ANA8/AMPBOUT	ADC Analog Input/OpAmp B Output	AFS1[3]: 1
	PD4	RXD1	UART 1 Receive Data	AFS1[4]: 0
		Reserved		AFS1[4]: 1
	PD5	TXD1	UART 1 Transmit Data	AFS1[5]: 0
		Reserved		AFS1[5]: 1
	PD6	DE1	UART 1 Driver Enable	AFS1[6]: 0
		Reserved		AFS1[6]: 1
	PD7	C0OUT	Comparator 0 Output	AFS1[7]: 0
		Reserved		AFS1[7]: 1

Notes

1. Because there are at most two choices of alternate function for some pins of Ports A, B, D, E and F, the Alternate Function Set register AFS2 is not implemented. Additionally, alternate function selection, as described in the Port A–J Alternate Function Subregisters ([see page 88](#)), must also be enabled.
2. The alternate function selection for Port C, as described in the Port A–J Alternate Function Subregisters ([see page 88](#)), must also be enabled.

Table 19. Port Alternate Function Mapping (Z8Fxx81 64-Pin Parts) (Continued)

Port	Pin	Mnemonic	Alternate Function Description	Alternate Function Set Subregisters
Port E ¹	PE0	DP	USB DP	AFS1[0]: 0
		T0IN/T0OUT	Timer 0 Input/Timer 0 Output Complement	AFS1[0]: 1
PE1	PE1	DM	USB DM	AFS1[1]: 0
		T0OUT	Timer 0 Output	AFS1[1]: 1
PE2	PE2	T4IN	Multi Channel Timer Input	AFS1[2]: 0
		Reserved		AFS1[2]: 1
PE3	PE3	T4CHA	Multi Channel Timer Input/Output A	AFS1[3]: 0
		ESOUT[0]	Event System Out 0	AFS1[3]: 1
PE4	PE4	T4CHB	Multi Channel Timer Input/Output B	AFS1[4]: 0
		ESOUT[1]	Event System Out 1	AFS1[4]: 1
PE5	PE5	T4CHC	Multi Channel Timer Input/Output C	AFS1[5]: 0
		ESOUT[2]	Event System Out 2	AFS1[5]: 1
PE6	PE6	T4CHD	Multi Channel Timer Input/Output D	AFS1[6]: 0
		ESOUT[3]	Event System Out 3	AFS1[6]: 1

Notes

1. Because there are at most two choices of alternate function for some pins of Ports A, B, D, E and F, the Alternate Function Set register AFS2 is not implemented. Additionally, alternate function selection, as described in the Port A–J Alternate Function Subregisters ([see page 88](#)), must also be enabled.
2. The alternate function selection for Port C, as described in the Port A–J Alternate Function Subregisters ([see page 88](#)), must also be enabled.

Table 19. Port Alternate Function Mapping (Z8Fxx81 64-Pin Parts) (Continued)

Port	Pin	Mnemonic	Alternate Function Description	Alternate Function Set Subregisters	
Port F ¹	PF0	ESOUT[0]	Event System Out 0	N/A	
		Reserved			
	PF1	ESOUT[1]	Event System Out 1		
		Reserved			
	PF2	ESOUT[2]	Event System Out 2		
		Reserved			
	PF3	ESOUT[3]	Event System Out 3		
		Reserved			
	PF4	Reserved			
		Reserved			
PF5	Reserved				
	Reserved				
PF6	SS1	SPI 1 Slave Select			
	Reserved				
PF7	MISO1	SPI 1 Master In Slave Out			
	Reserved				
Port G	PG0	SCK1	SPI 1 Serial Clock	N/A	
		Reserved			
	PG1	MOSI1	SPI 1 Master Out Slave In		
		Reserved			
	PG2	Reserved			
		Reserved			
	PG3	Reserved			
		Reserved			
	PG4	Reserved			
		Reserved			

Notes

1. Because there are at most two choices of alternate function for some pins of Ports A, B, D, E and F, the Alternate Function Set register AFS2 is not implemented. Additionally, alternate function selection, as described in the Port A–J Alternate Function Subregisters ([see page 88](#)), must also be enabled.
2. The alternate function selection for Port C, as described in the Port A–J Alternate Function Subregisters ([see page 88](#)), must also be enabled.

Table 20. Port Alternate Function Mapping (Z8Fxx82 64-Pin Parts)

Port	Pin	Mnemonic	Alternate Function Description	Alternate Function Set Subregisters
Port A ¹	PA0	T0IN/T0OUT	Timer 0 Input/Timer 0 Output Complement	AFS1[0]: 0
		CLKIN	External Clock Input	AFS1[0]: 1
	PA1	T0OUT	Timer 0 Output	AFS1[1]: 0
		Reserved		AFS1[1]: 1
	PA2	DE0	UART 0 Driver Enable	AFS1[2]: 0
		CLK2IN	External Clock 2 Input	AFS1[2]: 1
	PA3	CTS0	UART 0 Clear to Send	AFS1[3]: 0
		Reserved		AFS1[3]: 1
	PA4	RXD0/	UART 0 Receive Data	AFS1[4]: 0
		MOSI0	SPI 0 Master Out/Slave In	AFS1[4]: 1
	PA5	TXD0/	UART 0 Transmit Data	AFS1[5]: 0
		SCK0	SPI 0 Serial Clock	AFS1[5]: 1
	PA6	T1IN/T1OUT	Timer 1 Input/Timer 1 Output Complement	AFS1[6]: 0
		SCL	I ² C Serial Clock	AFS1[6]: 1
PA7	T1OUT	Timer 1 Output	AFS1[7]: 0	
	SDA	I ² C Serial Data	AFS1[7]: 1	

Notes

1. Because there are at most two choices of alternate function for some pins of Ports A, B, D, F, G and H, the Alternate Function Set register AFS2 is not implemented. Additionally, alternate function selection, as described in the Port A–J Alternate Function Subregisters ([see page 88](#)), must also be enabled.
2. The alternate function selection for Port C, as described in the Port A–J Alternate Function Subregisters ([see page 88](#)), must also be enabled.
3. Because there is only a single alternate function for each Port J pin, the Alternate Function Set registers are not implemented for Port J. Additionally, alternate function selection, as described in the Port A–J Alternate Function Subregisters ([see page 88](#)), must also be enabled.

Table 20. Port Alternate Function Mapping (Z8Fxx82 64-Pin Parts) (Continued)

Port	Pin	Mnemonic	Alternate Function Description	Alternate Function Set Subregisters
Port B ¹	PB0	Reserved		AFS1[0]: 0
		ANA0/AMPAOUT	ADC Analog Input/OpAmp A Output	AFS1[0]: 1
	PB1	Reserved		AFS1[1]: 0
		ANA1/AMPAINN	ADC Analog Input/OpAmp A Input (N)	AFS1[1]: 1
	PB2	Reserved		AFS1[2]: 0
		ANA2/AMPAINP	ADC Analog Input/OpAmp A Input (P)	AFS1[2]: 1
	PB3	Reserved		AFS1[3]: 0
		V _{REF-}	Voltage Reference (M)	AFS1[3]: 1
	PB4	Reserved		AFS1[4]: 0
		V _{REF+}	Voltage Reference (P)	AFS1[4]: 1
PB5	Reserved		AFS1[5]: 0	
	ANA9	ADC Analog Input	AFS1[5]: 1	
Port C ²	PC0	Reserved		AFS1[0]: 0, AFS2[0]: 0
		ANA4/VBIAS/C0INP	ADC or Voltage Bias with low current drive capability or Comparator 0 Input (P)	AFS1[0]: 1, AFS2[0]: 0
		Reserved		AFS1[0]: x, AFS2[0]: 1
	PC1	MISO0	SPI 0 Master In/Slave Out	AFS1[1]: 0, AFS2[1]: 0
		ANA5/C0INN	ADC or Comparator 0 Input (N)	AFS1[1]: 1, AFS2[1]: 0
		Reserved		AFS1[1]: x, AFS2[1]: 1
	PC2	SS0	SPI 0 Slave Select	AFS1[2]: 0, AFS2[2]: 0
		ANA3	ADC Analog Input	AFS1[2]: 1, AFS2[2]: 0
		Reserved		AFS1[2]: x, AFS2[2]: 1
	PC3	MISO0	SPI 0 Master In/Slave Out	AFS1[3]: 0, AFS2[3]: 0
		ANA11/DAC	ADC or DAC	AFS1[3]: 1, AFS2[3]: 0
		C0OUT	Comparator 0 Output	AFS1[3]: 0, AFS2[3]: 1
		Reserved		AFS1[3]: 1, AFS2[3]: 1

Notes

1. Because there are at most two choices of alternate function for some pins of Ports A, B, D, F, G and H, the Alternate Function Set register AFS2 is not implemented. Additionally, alternate function selection, as described in the Port A–J Alternate Function Subregisters ([see page 88](#)), must also be enabled.
2. The alternate function selection for Port C, as described in the Port A–J Alternate Function Subregisters ([see page 88](#)), must also be enabled.
3. Because there is only a single alternate function for each Port J pin, the Alternate Function Set registers are not implemented for Port J. Additionally, alternate function selection, as described in the Port A–J Alternate Function Subregisters ([see page 88](#)), must also be enabled.

Table 20. Port Alternate Function Mapping (Z8Fxx82 64-Pin Parts) (Continued)

Port	Pin	Mnemonic	Alternate Function Description	Alternate Function Set Subregisters
Port C ² (cont'd.)	PC4	MOSI0	SPI 0 Master Out/Slave In	AFS1[4]: 0, AFS2[4]: 0
		T0IN/T0OUT	Timer 0 Input/Timer 0 Output Complement	AFS1[4]: 1, AFS2[4]: 0
		SCL	I ² C Serial Clock	AFS1[4]: 0, AFS2[4]: 1
		DE0	UART 0 Driver Enable	AFS1[4]: 1, AFS2[4]: 1
	PC5	SCK0	SPI 0 Serial Clock	AFS1[5]: 0, AFS2[5]: 0
		T0OUT	Timer 0 Output	AFS1[5]: 1, AFS2[5]: 0
		SDA	I ² C Serial Data	AFS1[5]: 0, AFS2[5]: 1
		CTS0	UART 0 Clear to Send	AFS1[5]: 1, AFS2[5]: 1
	PC6	T2IN/T2OUT	Timer 2 Input/Timer 2 Output Complement	AFS1[6]: 0, AFS2[6]: 0
		SCKOUT	System Clock Out	AFS1[6]: 1, AFS2[6]: 0
		ESOUT[0]	Event System Output 0	AFS1[6]: 0, AFS2[6]: 1
		Reserved		AFS1[6]: 1, AFS2[6]: 1
PC7	T2OUT	Timer 2 Output	AFS1[7]: 0, AFS2[7]: 0	
	CTS1	UART 1 Clear to Send	AFS1[7]: 1, AFS2[7]: 0	
	ESOUT[1]	Event System Output 1	AFS1[7]: 0, AFS2[7]: 1	
	Reserved		AFS1[7]: 1, AFS2[7]: 1	
Port D ¹	PD0	RESET	External Reset	AFS1[0]: 0
		Reserved		AFS1[0]: 1

Notes

1. Because there are at most two choices of alternate function for some pins of Ports A, B, D, F, G and H, the Alternate Function Set register AFS2 is not implemented. Additionally, alternate function selection, as described in the Port A–J Alternate Function Subregisters ([see page 88](#)), must also be enabled.
2. The alternate function selection for Port C, as described in the Port A–J Alternate Function Subregisters ([see page 88](#)), must also be enabled.
3. Because there is only a single alternate function for each Port J pin, the Alternate Function Set registers are not implemented for Port J. Additionally, alternate function selection, as described in the Port A–J Alternate Function Subregisters ([see page 88](#)), must also be enabled.

Table 20. Port Alternate Function Mapping (Z8Fxx82 64-Pin Parts) (Continued)

Port	Pin	Mnemonic	Alternate Function Description	Alternate Function Set Subregisters
Port F ¹	PF0	ESOUT[0]	Event System Out 0	AFS1[0]: 0
		SEG2	LCD Segment	AFS1[0]: 1
PF1	PF1	ESOUT[1]	Event System Out 1	AFS1[1]: 0
		SEG7	LCD Segment	AFS1[1]: 1
PF2	PF2	ESOUT[2]	Event System Out 2	AFS1[2]: 0
		SEG8	LCD Segment	AFS1[2]: 1
PF3	PF3	ESOUT[3]	Event System Out 3	AFS1[3]: 0
		SEG9	LCD Segment	AFS1[3]: 1
PF4	PF4	Reserved		AFS1[4]: 0
		SEG10	LCD Segment	AFS1[4]: 1
PF5	PF5	Reserved		AFS1[5]: 0
		SEG15	LCD Segment	AFS1[5]: 1
PF6	PF6	SS1	SPI 1 Slave Select	AFS1[6]: 0
		SEG20	LCD Segment	AFS1[6]: 1
PF7	PF7	MISO1	SPI 1 Master In Slave Out	AFS1[7]: 0
		SEG23	LCD Segment	AFS1[7]: 1

Notes

1. Because there are at most two choices of alternate function for some pins of Ports A, B, D, F, G and H, the Alternate Function Set register AFS2 is not implemented. Additionally, alternate function selection, as described in the Port A–J Alternate Function Subregisters ([see page 88](#)), must also be enabled.
2. The alternate function selection for Port C, as described in the Port A–J Alternate Function Subregisters ([see page 88](#)), must also be enabled.
3. Because there is only a single alternate function for each Port J pin, the Alternate Function Set registers are not implemented for Port J. Additionally, alternate function selection, as described in the Port A–J Alternate Function Subregisters ([see page 88](#)), must also be enabled.

Table 20. Port Alternate Function Mapping (Z8Fxx82 64-Pin Parts) (Continued)

Port	Pin	Mnemonic	Alternate Function Description	Alternate Function Set Subregisters
Port G ¹	PG0	SCK1	SPI 1 Serial Clock	AFS1[0]: 0
		SEG21	LCD Segment	AFS1[0]: 1
	PG1	MOSI1	SPI 1 Master Out Slave In	AFS1[1]: 0
		SEG22	LCD Segment	AFS1[1]: 1
	PG2	Reserved		AFS1[2]: 0
		COM0	LCD Common	AFS1[2]: 1
	PG3	Reserved		AFS1[3]: 0
		COM1	LCD Common	AFS1[3]: 1
	PG4	Reserved		AFS1[4]: 0
		SEG0	LCD Segment	AFS1[4]: 1
	PG5	Reserved		AFS1[5]: 0
		SEG1	LCD Segment	AFS1[5]: 1
	PG6	Reserved		AFS1[6]: 0
		COM2	LCD Common	AFS1[6]: 1
PG7	Reserved		AFS1[7]: 0	
	COM3	LCD Common	AFS1[7]: 1	
Port H ¹	PH0	SEG19	LCD Segment	N/A
	PH1	SEG16	LCD Segment	
	PH2	SEG3	LCD Segment	
	PH3	SEG4	LCD Segment	
	PH4	SEG5	LCD Segment	
	PH5	SEG6	LCD Segment	
	PH6	SEG11	LCD Segment	
	PH7	SEG12	LCD Segment	

Notes

1. Because there are at most two choices of alternate function for some pins of Ports A, B, D, F, G and H, the Alternate Function Set register AFS2 is not implemented. Additionally, alternate function selection, as described in the Port A–J Alternate Function Subregisters ([see page 88](#)), must also be enabled.
2. The alternate function selection for Port C, as described in the Port A–J Alternate Function Subregisters ([see page 88](#)), must also be enabled.
3. Because there is only a single alternate function for each Port J pin, the Alternate Function Set registers are not implemented for Port J. Additionally, alternate function selection, as described in the Port A–J Alternate Function Subregisters ([see page 88](#)), must also be enabled.

Table 20. Port Alternate Function Mapping (Z8Fxx82 64-Pin Parts) (Continued)

Port	Pin	Mnemonic	Alternate Function Description	Alternate Function Set Subregisters
Port J³	PJ0	SEG13	LCD Segment	N/A
	PJ1	SEG14	LCD Segment	
	PJ2	SEG17	LCD Segment	
	PJ3	SEG18	LCD Segment	

Notes

1. Because there are at most two choices of alternate function for some pins of Ports A, B, D, F, G and H, the Alternate Function Set register AFS2 is not implemented. Additionally, alternate function selection, as described in the Port A–J Alternate Function Subregisters ([see page 88](#)), must also be enabled.
2. The alternate function selection for Port C, as described in the Port A–J Alternate Function Subregisters ([see page 88](#)), must also be enabled.
3. Because there is only a single alternate function for each Port J pin, the Alternate Function Set registers are not implemented for Port J. Additionally, alternate function selection, as described in the Port A–J Alternate Function Subregisters ([see page 88](#)), must also be enabled.

Table 21. Port Alternate Function Mapping, 80-Pin Parts

Port	Pin	Mnemonic	Alternate Function Description	Alternate Function Set Subregisters
Port A ¹	PA0	T0IN/T0OUT	Timer 0 Input/Timer 0 Output Complement	AFS1[0]: 0
		CLKIN	External Clock Input	AFS1[0]: 1
	PA1	T0OUT	Timer 0 Output	AFS1[1]: 0
		Reserved		AFS1[1]: 1
	PA2	DE0	UART 0 Driver Enable	AFS1[2]: 0
		CLK2IN	External Clock2 Input	AFS1[2]: 1
	PA3	CTS0	UART 0 Clear to Send	AFS1[3]: 0
		Reserved		AFS1[3]: 1
	PA4	RXD0/	UART 0 Receive Data	AFS1[4]: 0
		MOSI0	SPI 0 Master Out/Slave In	AFS1[4]: 1
	PA5	TXD0/	UART 0 Transmit Data	AFS1[5]: 0
		SCK0	SPI 0 Serial Clock	AFS1[5]: 1
	PA6	T1IN/T1OUT	Timer 1 Input/Timer 1 Output Complement	AFS1[6]: 0
		SCL	I ² C Serial Clock	AFS1[6]: 1
PA7	T1OUT	Timer 1 Output	AFS1[7]: 0	
	SDA	I ² C Serial Data	AFS1[7]: 1	

Notes

1. Because there are at most two choices of alternate function for some pins of Ports A, B, D, E, F and G, the Alternate Function Set Subregister AFS2 is not implemented. Also, alternate function selection, as described in the Port A–J Alternate Function Subregisters ([see page 88](#)) must also be enabled.
2. The alternate function selection for Port C, as described in the Port A–J Alternate Function Subregisters ([see page 88](#)) must also be enabled.
3. Because there is only a single alternate function for each pin in ports H and J, the Alternate Function Set subregisters are not implemented for these two ports. Also, alternate function selection, as described in the Port A–J Alternate Function Subregisters ([see page 88](#)) must also be enabled.

Table 21. Port Alternate Function Mapping, 80-Pin Parts (Continued)

Port	Pin	Mnemonic	Alternate Function Description	Alternate Function Set Subregisters
Port B ¹	PB0	Reserved		AFS1[0]: 0
		ANA0/AMPAOUT	ADC Analog Input/Op Amp A Output	AFS1[0]: 1
	PB1	Reserved		AFS1[1]: 0
		ANA1/AMPAINN	ADC Analog Input/Op Amp A Input (N)	AFS1[1]: 1
	PB2	Reserved		AFS1[2]: 0
		ANA2/AMPAINP	ADC Analog Input/Op Amp A Input (P)	AFS1[2]: 1
	PB3	Reserved		AFS1[3]: 0
		V _{REF-}	Voltage Reference (M)	AFS1[3]: 1
	PB4	Reserved		AFS1[4]: 0
		V _{REF+}	Voltage Reference (P)	AFS1[4]: 1
	PB5	Reserved		AFS1[5]: 0
		ANA9	ADC Analog Input	AFS1[5]: 1
	PB6	Reserved		AFS1[6]: 0
		ANA10	ADC Analog Input	AFS1[6]: 1
PB7	Reserved		AFS1[7]: 0	
	Reserved		AFS1[7]: 1	

Notes

1. Because there are at most two choices of alternate function for some pins of Ports A, B, D, E, F and G, the Alternate Function Set Subregister AFS2 is not implemented. Also, alternate function selection, as described in the Port A–J Alternate Function Subregisters ([see page 88](#)) must also be enabled.
2. The alternate function selection for Port C, as described in the Port A–J Alternate Function Subregisters ([see page 88](#)) must also be enabled.
3. Because there is only a single alternate function for each pin in ports H and J, the Alternate Function Set subregisters are not implemented for these two ports. Also, alternate function selection, as described in the Port A–J Alternate Function Subregisters ([see page 88](#)) must also be enabled.

Table 21. Port Alternate Function Mapping, 80-Pin Parts (Continued)

Port	Pin	Mnemonic	Alternate Function Description	Alternate Function Set Subregisters
Port C ²	PC0	Reserved		AFS1[0]: 0, AFS2[0]: 0
		ANA4/VBIAS/C0INP	ADC or Voltage Bias with low current drive capability or Comparator 0 Input (P)	AFS1[0]: 1, AFS2[0]: 0
		Reserved		AFS1[0]: x, AFS2[0]: 1
PC1	PC1	MISO0	SPI 0 Master In/Slave Out	AFS1[1]: 0, AFS2[1]: 0
		ANA5/C0INN	ADC or Comparator 0 Input (N)	AFS1[1]: 1, AFS2[1]: 0
		Reserved		AFS1[1]: x, AFS2[1]: 1
PC2	PC2	SS0	SPI 0 Slave Select	AFS1[2]: 0, AFS2[2]: 0
		ANA3	ADC Analog Input	AFS1[2]: 1, AFS2[2]: 0
		Reserved		AFS1[2]: x, AFS2[2]: 1
PC3	PC3	MISO0	SPI 0 Master In Slave Out	AFS1[3]: 0, AFS2[3]: 0
		ANA11/DAC	ADC or DAC	AFS1[3]: 1, AFS2[3]: 0
		Reserved		AFS1[3]: x, AFS2[3]: 1
PC4	PC4	MOSI0	SPI 0 Master Out/Slave In	AFS1[4]: 0, AFS2[4]: 0
		T0IN/T0OUT	Timer 0 Input/Timer 0 Output Complement	AFS1[4]: 1, AFS2[4]: 0
		SCL	I ² C Serial Clock	AFS1[4]: 0, AFS2[4]: 1
		DE0	UART 0 Driver Enable	AFS1[4]: 1, AFS2[4]: 1
PC5	PC5	SCK0	SPI 0 Serial Clock	AFS1[5]: 0, AFS2[5]: 0
		T0OUT	Timer 0 Output	AFS1[5]: 1, AFS2[5]: 0
		SDA	I ² C Serial Data	AFS1[5]: 0, AFS2[5]: 1
		CTS0	UART 0 Clear to Send	AFS1[5]: 1, AFS2[5]: 1
PC6	PC6	T2IN/T2OUT	Timer 2 Input/Timer2 Output Complement	AFS1[6]: 0, AFS2[6]: 0
		SCKOUT	System Clock Out	AFS1[6]: 1, AFS2[6]: 0
		ESOUT[0]	Event System Output 0	AFS1[6]: 0, AFS2[6]: 1
		Reserved		AFS1[6]: 1, AFS2[6]: 1

Notes

1. Because there are at most two choices of alternate function for some pins of Ports A, B, D, E, F and G, the Alternate Function Set Subregister AFS2 is not implemented. Also, alternate function selection, as described in the Port A–J Alternate Function Subregisters ([see page 88](#)) must also be enabled.
2. The alternate function selection for Port C, as described in the Port A–J Alternate Function Subregisters ([see page 88](#)) must also be enabled.
3. Because there is only a single alternate function for each pin in ports H and J, the Alternate Function Set subregisters are not implemented for these two ports. Also, alternate function selection, as described in the Port A–J Alternate Function Subregisters ([see page 88](#)) must also be enabled.

Table 21. Port Alternate Function Mapping, 80-Pin Parts (Continued)

Port	Pin	Mnemonic	Alternate Function Description	Alternate Function Set Subregisters
Port C² (cont'd.)	PC7	T2OUT	Timer 2 Output	AFS1[7]: 0, AFS2[7]: 0
		CTS1	UART 1 Clear to Send	AFS1[7]: 1, AFS2[7]: 0
		ESOUT[1]	Event System Output 1	AFS1[7]: 0, AFS2[7]: 1
		Reserved		AFS1[7]: 1, AFS2[7]: 1
Port D¹	PD0	RESET	External Reset	AFS1[0]: 0
		Reserved		AFS1[0]: 1
	PD1	C1INN	Comparator 1 Input (N)	AFS1[1]: 0
		ANA7/AMPBINN	ADC Analog Input/Op Amp B Input (N)	AFS1[1]: 1
	PD2	C1INP	Comparator 1 Input (P)	AFS1[2]: 0
		ANA6/AMPBINP	ADC Analog Input/Op Amp B Input (P)	AFS1[2]: 1
	PD3	C1OUT	Comparator 1 Output	AFS1[3]: 0
		ANA8/AMPBOUT	ADC Analog Input/Op Amp B Output	AFS1[3]: 1
	PD4	RXD1	UART 1 Receive Data	AFS1[4]: 0
		Reserved		AFS1[4]: 1
	PD5	TXD1	UART 1 Transmit Data	AFS1[5]: 0
		Reserved		AFS1[5]: 1
	PD6	DE1	UART 1 Driver Enable	AFS1[6]: 0
		Reserved		AFS1[6]: 1
	PD7	C0OUT	Comparator 0 Output	AFS1[7]: 0
		Reserved		AFS1[7]: 1

Notes

1. Because there are at most two choices of alternate function for some pins of Ports A, B, D, E, F and G, the Alternate Function Set Subregister AFS2 is not implemented. Also, alternate function selection, as described in the Port A–J Alternate Function Subregisters ([see page 88](#)) must also be enabled.
2. The alternate function selection for Port C, as described in the Port A–J Alternate Function Subregisters ([see page 88](#)) must also be enabled.
3. Because there is only a single alternate function for each pin in ports H and J, the Alternate Function Set subregisters are not implemented for these two ports. Also, alternate function selection, as described in the Port A–J Alternate Function Subregisters ([see page 88](#)) must also be enabled.

Table 21. Port Alternate Function Mapping, 80-Pin Parts (Continued)

Port	Pin	Mnemonic	Alternate Function Description	Alternate Function Set Subregisters
Port E ¹	PE0	DP	USB DP	AFS1[0]: 0
		T0IN/T0OUT	Timer 0 Input/Timer 0 Output Complement	AFS1[0]: 1
PE1	PE1	DM	USB DM	AFS1[1]: 0
		T0OUT	Timer 0 Output	AFS1[1]: 1
PE2	PE2	T4IN	Multi-Channel Timer Input	AFS1[2]: 0
		Reserved		AFS1[2]: 1
PE3	PE3	T4CHA	Multi-Channel Timer Input/Output A	AFS1[3]: 0
		ESOUT[0]	Event System Out 0	AFS1[3]: 1
PE4	PE4	T4CHB	Multi-Channel Timer Input/Output B	AFS1[4]: 0
		ESOUT[1]	Event System Out 1	AFS1[4]: 1
PE5	PE5	T4CHC	Multi-Channel Timer Input/Output C	AFS1[5]: 0
		ESOUT[2]	Event System Out 2	AFS1[5]: 1
PE6	PE6	T4CHD	Multi-Channel Timer Input/Output D	AFS1[6]: 0
		ESOUT[3]	Event System Out 3	AFS1[6]: 1

Notes

1. Because there are at most two choices of alternate function for some pins of Ports A, B, D, E, F and G, the Alternate Function Set Subregister AFS2 is not implemented. Also, alternate function selection, as described in the Port A–J Alternate Function Subregisters ([see page 88](#)) must also be enabled.
2. The alternate function selection for Port C, as described in the Port A–J Alternate Function Subregisters ([see page 88](#)) must also be enabled.
3. Because there is only a single alternate function for each pin in ports H and J, the Alternate Function Set subregisters are not implemented for these two ports. Also, alternate function selection, as described in the Port A–J Alternate Function Subregisters ([see page 88](#)) must also be enabled.

Table 21. Port Alternate Function Mapping, 80-Pin Parts (Continued)

Port	Pin	Mnemonic	Alternate Function Description	Alternate Function Set Subregisters
Port F ¹	PF0	ESOUT[0]	Event System Out 0	AFS1[0]: 0
		SEG2	LCD Segment	AFS1[0]: 1
PF1	PF1	ESOUT[1]	Event System Out 1	AFS1[1]: 0
		SEG7	LCD Segment	AFS1[1]: 1
PF2	PF2	ESOUT[2]	Event System Out 2	AFS1[2]: 0
		SEG8	LCD Segment	AFS1[2]: 1
PF3	PF3	ESOUT[3]	Event System Out 3	AFS1[3]: 0
		SEG9	LCD Segment	AFS1[3]: 1
PF4	PF4	Reserved		AFS1[4]: 0
		SEG10	LCD Segment	AFS1[4]: 1
PF5	PF5	Reserved		AFS1[5]: 0
		SEG15	LCD Segment	AFS1[5]: 1
PF6	PF6	SS1	SPI 1 Slave Select	AFS1[6]: 0
		SEG20	LCD Segment	AFS1[6]: 1
PF7	PF7	MISO1	SPI 1 Master In Slave Out	AFS1[7]: 0
		SEG23	LCD Segment	AFS1[7]: 1

Notes

1. Because there are at most two choices of alternate function for some pins of Ports A, B, D, E, F and G, the Alternate Function Set Subregister AFS2 is not implemented. Also, alternate function selection, as described in the Port A–J Alternate Function Subregisters ([see page 88](#)) must also be enabled.
2. The alternate function selection for Port C, as described in the Port A–J Alternate Function Subregisters ([see page 88](#)) must also be enabled.
3. Because there is only a single alternate function for each pin in ports H and J, the Alternate Function Set subregisters are not implemented for these two ports. Also, alternate function selection, as described in the Port A–J Alternate Function Subregisters ([see page 88](#)) must also be enabled.

Table 21. Port Alternate Function Mapping, 80-Pin Parts (Continued)

Port	Pin	Mnemonic	Alternate Function Description	Alternate Function Set Subregisters
Port G¹	PG0	SCK1	SPI 1 Serial Clock	AFS1[0]: 0
		SEG21	LCD Segment	AFS1[0]: 1
	PG1	MOSI1	SPI 1 Master Out Slave In	AFS1[1]: 0
		SEG22	LCD Segment	AFS1[1]: 1
	PG2	Reserved		AFS1[2]: 0
		COM0	LCD Common	AFS1[2]: 1
	PG3	Reserved		AFS1[3]: 0
		COM1	LCD Common	AFS1[3]: 1
	PG4	Reserved		AFS1[4]: 0
		SEG0	LCD Segment	AFS1[4]: 1
	PG5	Reserved		AFS1[5]: 0
		SEG1	LCD Segment	AFS1[5]: 1
	PG6	Reserved		AFS1[6]: 0
		COM2	LCD Common	AFS1[6]: 1
PG7	Reserved		AFS1[7]: 0	
	COM3	LCD Common	AFS1[7]: 1	
Port H³	PH0	SEG19	LCD Segment	N/A
	PH1	SEG16	LCD Segment	
	PH2	SEG3	LCD Segment	
	PH3	SEG4	LCD Segment	
	PH4	SEG5	LCD Segment	
	PH5	SEG6	LCD Segment	
	PH6	SEG11	LCD Segment	
	PH7	SEG12	LCD Segment	

Notes

1. Because there are at most two choices of alternate function for some pins of Ports A, B, D, E, F and G, the Alternate Function Set Subregister AFS2 is not implemented. Also, alternate function selection, as described in the Port A–J Alternate Function Subregisters ([see page 88.](#)) must also be enabled.
2. The alternate function selection for Port C, as described in the Port A–J Alternate Function Subregisters ([see page 88.](#)) must also be enabled.
3. Because there is only a single alternate function for each pin in ports H and J, the Alternate Function Set subregisters are not implemented for these two ports. Also, alternate function selection, as described in the Port A–J Alternate Function Subregisters ([see page 88.](#)) must also be enabled.

Table 21. Port Alternate Function Mapping, 80-Pin Parts (Continued)

Port	Pin	Mnemonic	Alternate Function Description	Alternate Function Set Subregisters
Port J ³	PJ0	SEG13	LCD Segment	N/A
	PJ1	SEG14	LCD Segment	
	PJ2	SEG17	LCD Segment	
	PJ3	SEG18	LCD Segment	

Notes

1. Because there are at most two choices of alternate function for some pins of Ports A, B, D, E, F and G, the Alternate Function Set Subregister AFS2 is not implemented. Also, alternate function selection, as described in the Port A–J Alternate Function Subregisters ([see page 88](#)) must also be enabled.
2. The alternate function selection for Port C, as described in the Port A–J Alternate Function Subregisters ([see page 88](#)) must also be enabled.
3. Because there is only a single alternate function for each pin in ports H and J, the Alternate Function Set subregisters are not implemented for these two ports. Also, alternate function selection, as described in the Port A–J Alternate Function Subregisters ([see page 88](#)) must also be enabled.

7.9. GPIO Interrupts

Many of the GPIO port pins can be used as interrupt sources. Some port pins can be configured to generate an interrupt request on either the rising edge or falling edge of the pin-input signal. Other port-pin interrupt sources generate an interrupt when any edge occurs (both rising and falling). To learn more about interrupts using the GPIO pins, see the [Interrupt Controller](#) chapter on page 127.

7.10. GPIO Control Register Definitions

Four registers for each port provide access to GPIO control, input data, and output data. Table 22 lists these port registers. Use the Port A–J address and control registers together to provide access to their subregisters for port configuration and control.

Table 22. GPIO Port Registers and Subregisters

Port Register Mnemonic	Port Register Name
PxADDR	Port A–J Address Register (Selects subregisters)
PxCTL	Port A–J Control Register (Provides access to subregisters)
PxIN	Port A–J Input Data Register
PxOUT	Port A–J Output Data Register
PxDD	Data Direction
PxAF	Alternate Function

Table 22. GPIO Port Registers and Subregisters (Continued)

Port Register Mnemonic	Port Register Name
PxOC	Output Control (Open-Drain)
PxHDE	High Drive Enable
PxSMRE	Stop-Mode Recovery Source Enable
PxPUE	Pull-up Enable
PxAFS1	Alternate Function Set 1
PxAFS2	Alternate Function Set 2

7.10.1. Port A–J Address Registers

The Port A–J address registers select the GPIO Port functionality accessible through the Port A–J Control registers. The Port A–J Address and Control registers combine to provide access to all GPIO Port controls, see Table 23.

Table 23. Port A–J GPIO Address Registers (PxADDR)

Bit	7	6	5	4	3	2	1	0
Field	PADDR[7:0]							
Reset	00h							
R/W	R/W	R/W	R/W	R/W	R/W	R/W	R/W	R/W
Address	Port A @ FD0h, Port B @ FD4h, Port C @ FD8h, Port D @ FDCh, Port E @ FE0h, Port F @ FE4h, Port G @ FE8h, Port H @ FECh, Port J @ FBCCh							
Note: x = A, B, C, D, E, F, G, H, or J.								

Bit	Description
[7:0]	Port A Address Registers
PxADDR	The port address selects one of the subregisters, which are accessible through the Port Control Register. 00h: No function; provides some protection against accidental port reconfiguration. 01h: Data Direction. 02h: Alternate Function. 03h: Output Control (Open-Drain). 04h: High Drive Enable. 05h: Stop-Mode Recovery Source Enable. 06h: Pull-up Enable. 07h: Alternate Function Set 1. 08h: Alternate Function Set 2. 09h–FFh: No function.

7.10.2. Port A–J Control Registers

The Port A–J Control registers, shown in Table 24, set the GPIO port operation. The value in the corresponding Port A–J Address Register determines which subregister is read from or written to by a Port A–J Control Register transaction.

Table 24. Port A–J Control Registers (PxCTL)

Bit	7	6	5	4	3	2	1	0
Field	PCTL							
Reset	00h							
R/W	R/W	R/W	R/W	R/W	R/W	R/W	R/W	R/W
Address	Port A @ FD1h, Port B @ FD5h, Port C @ FD9h, Port D @ FDDh, Port E @ FE1h, Port F @ FE5h, Port G @ FE9h, Port H @ FEDh, Port J @ FBDh							
Note: x = A, B, C, D, E, F, G, H, or J.								

Bit	Description
[7:0] PxCTL	Port Control The Port Control Register provides access to all subregisters that configure GPIO port operation.

7.10.3. Port A–J Data Direction Subregisters

The Port A–J Data Direction Subregister, shown in Table 25, is accessed through the Port A–J Control Register by writing 01h to the Port A–J Address Register.

Table 25. Port A–J Data Direction Subregisters (PxDD)

Bit	7	6	5	4	3	2	1	0
Field	DD7	DD6	DD5	DD4	DD3	DD2	DD1	DD0
Reset	1	1	1	1	1	1	1	1
R/W	R/W	R/W	R/W	R/W	R/W	R/W	R/W	R/W
Address	If 01h in Port A–J Address Register, accessible through the Port A–J Control Register							
Note: x = A, B, C, D, E, F, G, H, or J.								

Bit	Description
[7:0] PxDD	Data Direction These bits control the direction of the associated port pin. Port Alternate Function operation overrides the Data Direction Register setting. 0: Output. Data in the Port A–J Output Data Register is driven onto the port pin. 1: Input. The port pin is sampled and the value written into the Port A–J Input Data Register. The output driver is tristated.

7.10.4. Port A–J Alternate Function Subregisters

The Port A–J Alternate Function Subregister, shown in Table 26, is accessed through the Port A–J Control Register by writing 02h to the Port A–J Address Register. The Port A–J Alternate Function subregisters enable the alternate function selection on pins. If disabled, pins functions as GPIO. If enabled, select one of the four alternate functions using Alternate Function set subregisters 1 and 2 as described in the [Port A–G Alternate Function Set 1 Subregisters](#) section on page 92 and the [Alternate function selection on the port pins must also be enabled as described in the Port A–J Alternate Function Subregisters section on page 88.](#) section on page 92. To determine the alternate function associated with each port pin, see the [GPIO Alternate Functions](#) section on page 56.



Caution: Do not enable alternate functions for GPIO port pins for which there is no associated alternate function. Failure to follow this guideline results in unpredictable operation.

Table 26. Port A–J Alternate Function Subregisters (PxAF)

Bit	7	6	5	4	3	2	1	0
Field	AF7	AF6	AF5	AF4	AF3	AF2	AF1	AF0
Reset	00h (Ports A–C); 01h (Port D); 00h (Ports E–J)							
R/W	R/W							
Address	If 02h in Port A–J Address Register, accessible through the Port A–J Control Register							
Note: x = A, B, C, D, E, F, G, H, or J.								

Bit	Description
[7:0] PxAF	<p>Port Alternate Function Enable</p> <p>0: The port pin is in Normal Mode and the DDx bit in the Port A–J Data Direction Subregister determines the direction of the pin.</p> <p>1: The alternate function selected through Alternate Function set subregisters are enabled. Port pin operation is controlled by the alternate function.</p>

7.10.5. Port A–J Output Control Subregisters

The Port A–J Output Control Subregister, shown in Table 27, is accessed through the Port A–J Control Register by writing 03h to the Port A–J Address Register. Setting the bits in the Port A–J Output Control subregisters to 1 configures the specified port pins for open-drain operation. These subregisters affect the pins directly and, as a result, alternate functions are also affected.

Table 27. Port A–J Output Control Subregisters (PxOC)

Bit	7	6	5	4	3	2	1	0
Field	POC7	POC6	POC5	POC4	POC3	POC2	POC1	POC0
Reset	0	0	0	0	0	0	0	0
R/W	R/W	R/W	R/W	R/W	R/W	R/W	R/W	R/W
Address	If 03h in Port A–J Address Register, accessible through the Port A–J Control Register							

Note: x = A, B, C, D, E, F, G, H, or J.

Bit	Description
[7:0] PxOC	<p>Port Output Control</p> <p>These bits function independently of the alternate function bit and always disable the drains if set to 1.</p> <p>0: The drains are enabled for any output mode (unless overridden by the alternate function).</p> <p>1: The drain of the associated pin is disabled (open-drain mode).</p>

7.10.6. Port A–J High Drive Enable Subregisters

The Port A–J High Drive Enable Subregister, shown in Table 28, is accessed through the Port A–J Control Register by writing 04h to the Port A–J Address Register. Setting the bits in the Port A–J High Drive Enable subregisters to 1 configures the specified port pins for high-current output drive operation. The Port A–J High Drive Enable Subregister affects the pins directly and, as a result, alternate functions are also affected.

Table 28. Port A–J High Drive Enable Subregisters (PxHDE)

Bit	7	6	5	4	3	2	1	0
Field	PHDE7	PHDE6	PHDE5	PHDE4	PHDE3	PHDE2	PHDE1	PHDE0
Reset	0	0	0	0	0	0	0	0
R/W	R/W	R/W	R/W	R/W	R/W	R/W	R/W	R/W
Address	If 04h in Port A–J Address Register, accessible through the Port A–J Control Register							

Note: x = A, B, C, D, E, F, G, H, or J.

Bit	Description
[7:0] PxHDE	<p>Port High Drive Enabled</p> <p>0: The port pin is configured for standard output current drive.</p> <p>1: The port pin is configured for high output current drive.</p>

7.10.7. Port A–G Stop-Mode Recovery Source Enable Subregisters

The Port A–G Stop-Mode Recovery Source Enable Subregister, shown in Table 29, is accessed through Port A–G Control Register by writing 05h to the Port A–G Address Register. Setting the bits in the Port A–G Stop-Mode Recovery Source Enable subregisters to 1 configures the specified Port pins as a Stop-Mode Recovery source. During Stop Mode, any logic transition on a Port pin enabled as a Stop-Mode Recovery source initiates Stop-Mode Recovery.

Table 29. Port A–G Stop-Mode Recovery Source Enable Subregisters (PxSMRE)

Bit	7	6	5	4	3	2	1	0
Field	PSMRE7	PSMRE6	PSMRE5	PSMRE4	PSMRE3	PSMRE2	PSMRE1	PSMRE0
Reset	0	0	0	0	0	0	0	0
R/W	R/W	R/W	R/W	R/W	R/W	R/W	R/W	R/W
Address	If 05h in Port A–G Address Register, accessible through the Port A–G Control Register							

Note: x = A, B, C, D, E, F, G, H, or J.

Bit	Description
[7:0] PxSMRE	<p>Port Stop-Mode Recovery Source Enabled</p> <p>0: The port pin is not configured as a Stop-Mode Recovery source. Transitions on this pin during Stop Mode do not initiate a Stop-Mode Recovery.</p> <p>1: The port pin is configured as a Stop-Mode Recovery source. Any logic transition on this pin during Stop Mode initiates a Stop-Mode Recovery.</p> <p>Note: PortD0/RESET does not function as a Stop-Mode Recovery source.</p>

7.10.8. Port A–J Pull-up Enable Subregisters

The Port A–J Pull-up Enable Subregister, shown in Table 30, is accessed through the Port A–J Control Register by writing 06h to the Port A–J Address Register. Setting the bits in the Port A–J Pull-up Enable subregisters enables a weak internal resistive pull-up on the specified Port pins.

Table 30. Port A–J Pull-Up Enable Subregisters (PxPUE)

Bit	7	6	5	4	3	2	1	0
Field	PPUE7	PPUE6	PPUE5	PPUE4	PPUE3	PPUE2	PPUE1	PPUE0
Reset	0	0	0	0	0	0	0	0
R/W	R/W	R/W	R/W	R/W	R/W	R/W	R/W	R/W
Address	If 06h in Port A–J Address Register, accessible through the Port A–J Control Register							
Note: x = A, B, C, D, E, F, G, H, or J.								

Bit	Description
[7:0] PxPUE	Port Pull-up Enabled 0: The weak pull-up on the port pin is disabled. 1: The weak pull-up on the port pin is enabled.

7.10.9. Port A–G Alternate Function Set 1 Subregisters

The Port A–G Alternate Function Set1 Subregister, shown in Table 31, is accessed through the Port A–G Control Register by writing 07h to the Port A–G Address Register. The Alternate Function Set 1 subregisters select the alternate function available at a port pin. Alternate Functions selected by setting or clearing bits of this register are defined in the [GPIO Alternate Functions](#) section on page 56.

Table 31. Port A–G Alternate Function Set 1 Subregisters (PxAFS1)

Bit	7	6	5	4	3	2	1	0
Field	PAFS17	PAFS16	PAFS15	PAFS14	PAFS13	PAFS12	PAFS11	PAFS10
Reset	0	0	0	0	0	0	0	0
R/W	R/W	R/W	R/W	R/W	R/W	R/W	R/W	R/W
Address	If 07h in Port A–G Address Register, accessible through the Port A–G Control Register							

Note: x = A, B, C, D, E, F, G, H, or J.

Bit	Description
[7:0] PxAFS1	PAFS1[7:0] – Port Alternate Function Set 1 0: Port Alternate Function selected, as defined in Tables 17 through 21 in the GPIO Alternate Functions section on page 56. 1: Port Alternate Function selected, as defined in Tables 17 through 18 in the GPIO Alternate Functions section on page 56.

► **Note:** Alternate function selection on the port pins must also be enabled as described in the [Port A–J Alternate Function Subregisters](#) section on page 88.

7.10.10. Port C Alternate Function Set 2 Subregister

The Port C Alternate Function Set 2 Subregister, shown in Table 32, is accessed through the Port C Control Register by writing 08h to the Port C Address Register. The Alternate Function Set 2 Subregister selects the alternate function available at a port pin. Alternate Functions selected by setting or clearing bits of this register is defined in [Tables 17 through 21](#) in the [GPIO Alternate Functions](#) section on page 56.

Table 32. Port C Alternate Function Set 2 Subregisters (PxAFS2)

Bit	7	6	5	4	3	2	1	0
Field	PAFS27	PAFS26	PAFS25	PAFS24	PAFS23	PAFS22	PAFS21	PAFS20
Reset	0	0	0	0	0	0	0	0
R/W	R/W	R/W	R/W	R/W	R/W	R/W	R/W	R/W
Address	If 08h in Port C Address Register, accessible through the Port C Control Register							

Note: x = A, B, C, D, E, F, G, H, or J.

Bit	Description
[7:0]	Port Alternate Function Set 2
PxAFS2	0: Port Alternate Function selected, as defined in Tables 17 through 21 in the GPIO Alternate Functions section on page 56. 1: Port Alternate Function selected, as defined in Tables 17 through 21 in the GPIO Alternate Functions section on page 56.

► **Note:** Alternate function selection on port pins must also be enabled as described in the [Port A–J Alternate Function Subregisters](#) section on page 88.

7.10.11. Port A–J Input Data Registers

Reading from the Port A–J Input Data registers, shown in Table 33, returns the sampled values from the corresponding port pins. The Port A–J Input Data registers are read-only. The value returned for any unused ports is 0. Unused ports include those missing on the packages other than the 80-pin package.

Table 33. Port A–J Input Data Registers (PxIN)

Bit	7	6	5	4	3	2	1	0
Field	PIN7	PIN6	PIN5	PIN4	PIN3	PIN2	PIN1	PIN0
Reset	X	X	X	X	X	X	X	X
R/W	R	R	R	R	R	R	R	R
Address	Port A @ FD2h, Port B @ FD6h, Port C @ FDAh, Port D @ FDEh, Port E @ FE2h, Port F @ FE6h, Port G @ FEAh, Port H @ FEEh, Port J @ FBEh							
Note: x = A, B, C, D, E, F, G, H, or J.								

Bit	Description
[7:0] PxIN	<p>Port Input Data Sampled data from the corresponding port pin input. 0: Input data is logical 0 (Low). 1: Input data is logical 1 (High).</p>

7.10.12. Port A–J Output Data Register

The Port A–J Output Data Register, shown in Table 34, controls the output data to the pins.

Table 34. Port A–J Output Data Register (PxOUT)

Bit	7	6	5	4	3	2	1	0
Field	POUT7	POUT6	POUT5	POUT4	POUT3	POUT2	POUT1	POUT0
Reset	0	0	0	0	0	0	0	0
R/W	R/W	R/W	R/W	R/W	R/W	R/W	R/W	R/W
Address	Port A @ FD3h, Port B @ FD7h, Port C @ FDBh, Port D @ FDFh, Port E @ FE3h, Port F @ FE7h, Port G @ FECh, Port H @ FEFh, Port J @ FBFh							
Note: x = A, B, C, D, E, F, G, H, or J.								

Bit	Description
[7:0] PxOUT	<p>Port Output Data</p> <p>These bits contain the data to be driven to the port pins. The values are only driven if the corresponding pin is configured as an output and the pin is not configured for Alternate Function operation.</p> <p>0: Drive a logical 0 (Low).</p> <p>1: Drive a logical 1 (High). High value is not driven if the drain has been disabled by setting the corresponding Port Output Control Register bit to 1.</p>

Chapter 8. Clock System

The F6482 Series devices use seven possible clock sources, each user-selectable:

- On-chip Internal Precision Oscillator (IPO)
- On-chip Digitally Controlled Oscillator (DCO)
- On-chip High Frequency Crystal Oscillator (HFXO) using off-chip crystal or resonator
- On-chip Low Frequency Crystal Oscillator (LFXO) using off-chip crystal
- Two external clock drives
- On-chip Watchdog Timer Oscillator (WTO)

Two internal clock multiplication systems are available:

- An on-chip Frequency Locked Loop (FLL) which locks the DCO to Peripheral Clock (PCLK, an internal clock)
- An on-chip Phase Locked Loop (PLL) which can clock the USB and/or source System Clock and locks to either the HFXO or external clock drive

Four internal clocks exist and are configured to the clock sources as follows:

- System Clock (SYSCLK) is the clock input to the CPU as well as other system functions. The five possible clock sources for System Clock are:
 - Peripheral Clock (PCLK), a derived clock
 - DCO which can be locked to PCLK using the FLL
 - HFXO or External clock drive (based on PLL clock source select)
 - PLL clock sourced by the HFXO or external clock drive
 - WTO
- Peripheral Clock (PCLK) is the 32.768kHz clock input to the DCO and can be selected to clock certain peripherals. The three possible clock sources for PCLK are:
 - IPO
 - LFXO
 - External clock 2 drive
- The WTO is the clock input to the Watchdog Timer (WDT) and can be selected to clock certain peripherals

- The PLL Clock (PLL_{CLK}) is driven by the on-chip PLL and it can clock the USB and/or System Clock. The two possible sources for the PLL are:
 - HFXO
 - External clock drive

In addition, F6482 Series devices contain:

- A clock failure detection and recovery circuitry allowing continued operation despite a failure of the System Clock source
- A clock failure detection circuitry allowing detection of a failure of the Watchdog Timer Oscillator (WTO)
- A divider circuit to reduce the frequency of the selected System Clock source. The divider selection can be altered dynamically to quickly increase or decrease System Clock frequency to manage performance and power consumption

8.1. Architecture

This chapter discusses the oscillator control system including clock sources such as oscillators, clock multiplication, selection of clock sources for internal clocks and oscillator failure detection. A diagram of the oscillator control system is shown in Figure 11.

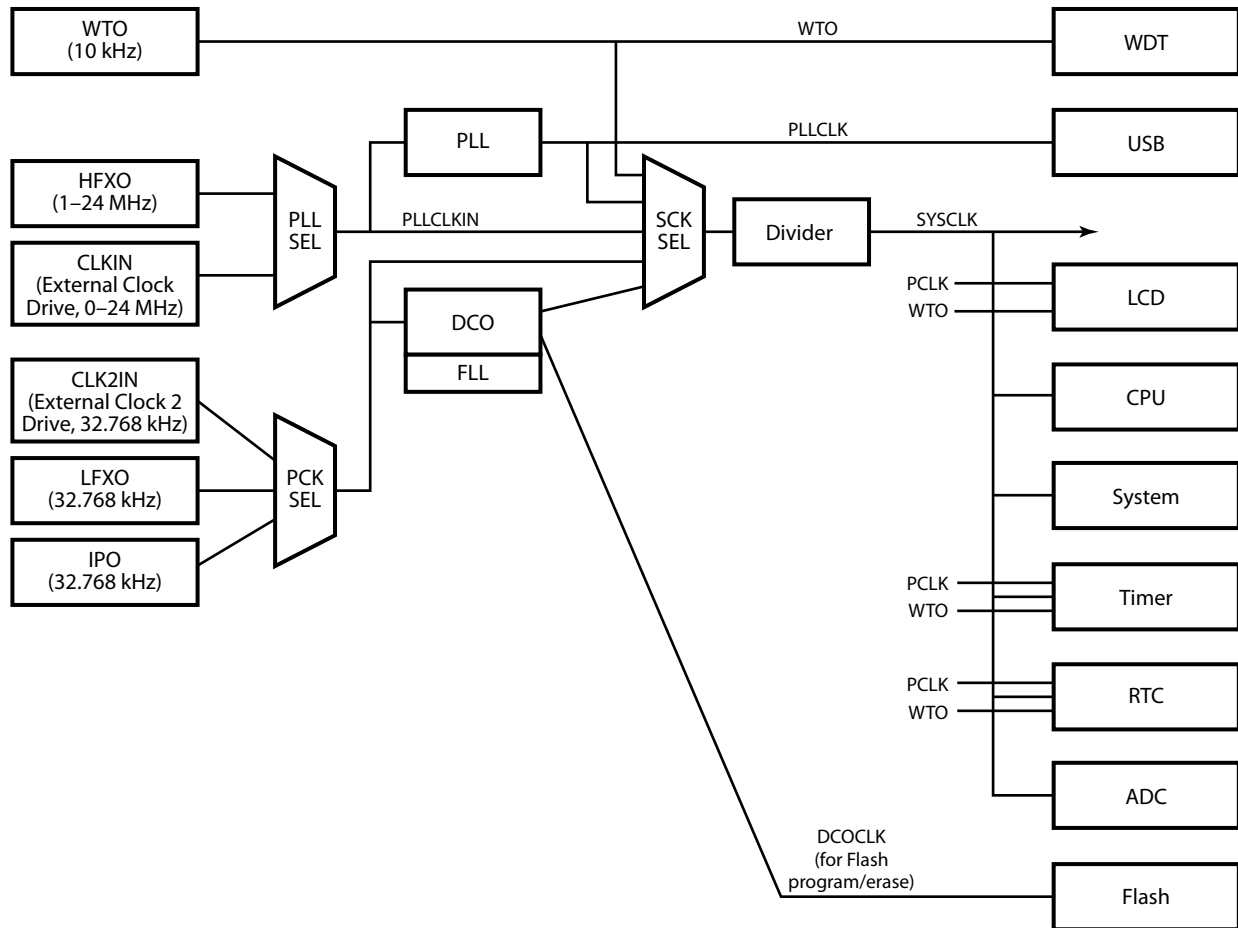

Figure 11. Clock System Block Diagram

8.2. Clock Selection

Clock sources can be selected for System Clock, Peripheral Clock, and PLL Clock.

8.2.1. System Clock Selection

The Clock System selects from the available clock sources. Table 35 details each clock source and its usage.

Table 35. System Clock Configuration and Selection

Clock Source	Characteristics	Required Setup
Digitally Controlled Oscillator (DCO)	Running without FLL <ul style="list-style-type: none"> • Frequency range 1–24MHz • No external components required 	<ul style="list-style-type: none"> • Unlock the Clock Control registers and configure the DCO • Switch System Clock sources as described in the System Clock Source Switching section on page 100
	Running with FLL <ul style="list-style-type: none"> • Performs clock multiplication • Frequency range 1–24MHz • Accuracy 0.25% (vs. PCLK) • No external components required 	<ul style="list-style-type: none"> • Unlock the Clock Control registers • Configure Peripheral Clock (PCLK) • Configure the FLL • Switch System Clock sources as described in the System Clock Source Switching section on page 100
Peripheral Clock	<ul style="list-style-type: none"> • See Table 36 on page 101 	<ul style="list-style-type: none"> • Unlock the Clock Control registers and configure Peripheral Clock (PCLK) • Switch System Clock sources as described in the System Clock Source Switching section on page 100
High Frequency Crystal/Oscillator (HFXO)	<ul style="list-style-type: none"> • 1MHz to 24 MHz • Very high accuracy (dependent on crystal or resonator used) • External components required 	<ul style="list-style-type: none"> • Unlock the Clock Control registers and configure the HFXO control bits for correct external oscillator mode • Switch System Clock sources as described in the System Clock Source Switching section on page 100
External Clock Drive	<ul style="list-style-type: none"> • 0 to 24 MHz • Accuracy dependent on external clock source 	<ul style="list-style-type: none"> • Unlock the Clock Control registers and configure the HFXOBAND for correct external clock drive frequency • Write GPIO registers to configure PA0 pin for external clock function, CLKIN • Apply external clock signal to GPIO • Switch System Clock sources as described in the System Clock Source Switching section on page 100

Table 35. System Clock Configuration and Selection (Continued)

Clock Source	Characteristics	Required Setup
Phase Locked Loop (PLL)	<ul style="list-style-type: none"> • 10 to 48MHz • Performs clock multiplication • Very high accuracy (dependent on clock source used) • External components if using HFXO as clock source 	<ul style="list-style-type: none"> • Enable the desired PLL clock source and wait until it is ready • Unlock the Clock Control registers and configure the PLL • Switch System Clock sources as described in the System Clock Source Switching section on page 100
Internal WDT Oscillator (WTO)	<ul style="list-style-type: none"> • 10 kHz nominal • ± 40% accuracy; no external components required • Low power consumption 	<ul style="list-style-type: none"> • Switch System Clock sources as described in the System Clock Source Switching section on page 100



Caution: Unintentional accesses to the Clock System Control registers can result in the use of unintended clock sources and/or clock frequencies. To prevent this condition, the oscillator control block employs a register unlocking/locking scheme.

8.2.1.1. System Clock Source Switching

System Clock source switching provides glitch free operation in that changing the clock source or prescale setting will not cause clock glitches. In accomplishing glitch free clock switching operation, there is a delay from the writing of SCKSEL to the actual switching from the currently active clock source to the new, desired clock source. To switch from one System Clock source to another, observe the following procedure:

1. Unlock the clock control registers.
2. Write to the appropriate clock control registers to configure the desired clock source.
3. Enable the desired clock source.
4. Wait for the newly enabled clock source to stabilize by polling the appropriate ready bit.
5. Write CLKCTL0 to select System Clock. The byte written to CLKCTL0 should have CSTAT set if it desired to leave the system clock registers unlocked.
6. After the System Clock source has been switched, disable any unnecessary clock sources, if desired.
7. The clock control registers can be locked by clearing CSTAT.

8.2.1.2. System Clock Divider

The clock source selected to be System Clock can be divided prior to driving System Clock. The clock divider provides glitch free operation in that changing the divider setting will not cause clock glitches. This allows software quickly to increase or decrease System Clock frequency to manage performance and power consumption.

8.2.2. Peripheral Clock Selection

The Peripheral Clock (PCLK) operates at 32.768kHz (nominal). It is the DCO clock source and can be selected to be the clock for several peripherals. PCLK can be configured operate during Stop Mode by setting PCKSM in the Clock Control Register and, if the IPO is selected as the source for PCLK, by also setting FRECOV in the Power Control 0 Register. If switching the PCLK clock source, Zilog recommends first disabling any peripheral that is clocked by PCLK.

If the DCO is selected as System Clock with the FLL enabled, disable the FLL prior to selecting a new PCLK source. When PCLK is driven by the new source, the FLL can be enabled.

Table 36 summarizes peripheral clock sources and usage.

Table 36. Peripheral Clock Sources and Usage

PCLK Sources	Characteristics	Required Setup
Low Frequency Crystal Oscillator (LFXO)	<ul style="list-style-type: none"> Optimized for use with a 32.768 kHz Watch Crystal Very high accuracy Dedicated XTAL pins External components required 	<ul style="list-style-type: none"> Unlock the Clock Control registers Enable the LFXO Switch System Clock sources as described in the PCLK Source Switching section on page 102 Select PCLK as the clock source for any desired peripheral(s) in the appropriate peripheral control register(s)

Table 36. Peripheral Clock Sources and Usage

PCLK Sources	Characteristics	Required Setup
Internal Precision Oscillator (IPO)	<ul style="list-style-type: none"> • 32.768kHz nominal • ± 2% accuracy with factory trim • No external components required 	<ul style="list-style-type: none"> • Unlock the Clock Control registers • Enable the IPO • Switch System Clock sources as described in the PCLK Source Switching section on page 102 • Select PCLK as the clock source for any desired peripheral(s) in the appropriate peripheral control register(s)
External Clock 2 Drive	<ul style="list-style-type: none"> • 32.768kHz when used as PCLK source • Accuracy dependent on external clock source 	<ul style="list-style-type: none"> • Write GPIO registers to configure PA2 pin for external clock function, CLK2IN • Apply external clock signal to GPIO • Unlock the Clock Control registers • Switch System Clock sources as described in the PCLK Source Switching section on page 102 • Select PCLK as the clock source for any desired peripheral(s) in the appropriate peripheral control register(s)

8.2.2.1. PCLK Source Switching

PCLK source switching provides glitch free operation in that changing the clock source or prescale setting will not cause clock glitches. In accomplishing glitch free clock switching operation, there is a delay from the writing of PCKSEL to the actual switching from the currently active clock source to the new, desired clock source. To switch from one PCLK source to another, observe the following procedure:

1. Unlock the clock control registers.
2. Write to the appropriate clock control registers to configure the desired clock source.
3. Enable the desired clock source.
4. Wait for the newly enabled clock source to stabilize.
5. Write CLKCTL1 to select PCLK.
6. After the System Clock source has been switched, disable any unnecessary clock sources, if desired.
7. The clock control registers can be locked by clearing CSTAT.

8.2.3. PLL Clock Selection

The PLL Clock (PLL_{CLK}) is driven by the on-chip PLL. The two possible sources for the PLL are the High Frequency Crystal Oscillator (HFXO) and the External Clock Drive.

Clock source selection is performed with PLLSEL and the source selected by PLLSEL is available both to the PLL and as a System Clock source selectable using SCKSEL. The PLL should be enabled only when the selected clock source is ready.

When using the USB, the PLL must be enabled to provide a 48MHz clock to the USB.

8.2.4. Clock System Control Register Unlocking/Locking

Before writing a clock system control register (CLKCTLx), the clock control registers must be unlocked by making two writes to the CLKCTL0 Register with the value E7h followed by the value 18h. Successful unlocking sets CSTAT. When unlocked, one or more CLKCTLx registers can be written. The clock control registers can be again locked by clearing CSTAT in CLKCTL0. Any other sequence of clock system control register writes has no effect. The values written to unlock the register must be ordered correctly, but are not necessarily consecutive. It is possible to write to or read from other registers within the unlocking/locking operation. To remain unlocked when writing CLKCTL0, the byte written to CLKCTL0 must have CSTAT set.

► **Note:** Before writing the unlock sequence, check that CSTAT is cleared. If the unlock sequence is written while CSTAT is set, the CLKCTL0 Register will be loaded with the unlock sequence values.

When selecting a new clock source, the System Clock failure detection circuitry and the Watchdog Timer oscillator failure circuitry must be disabled. If SCKFEN and WTOFEN are not disabled prior to a clock switch-over, it is possible to generate an interrupt for a failure of either oscillator. The Failure detection circuitry can be enabled anytime after a successful write of SCKSEL in the CLKCTL0 Register.

8.3. Clock Failure Detection and Recovery

Clock failure detection and recovery features are provided for the System Clock. A clock failure detection feature is provided for the Watchdog Timer oscillator.

8.3.1. System Clock Failure

The F6482 Series devices can generate nonmaskable interrupt-like events when the System Clock source fails. To maintain system function in this situation, when SCKFEN=1, the clock failure recovery circuitry automatically forces the Watchdog Timer Oscillator (WTO) to drive System Clock. The WTO is enabled automatically to allow the recovery. Although this oscillator runs at a much slower speed than the original system clock, the CPU continues to operate allowing execution of a clock failure vector and software rou-

tines that either remedy the oscillator failure or issue a failure alert. This automatic switch-over is not available if WTO is the System Clock source.

The System Clock source failure detection circuitry asserts if the System Clock frequency drops below $1\text{ kHz} \pm 50\%$. If an external signal is selected as the System Clock source, it is possible that a very slow but nonfailing clock can generate a failure condition. Under these conditions, do not enable the System Clock failure circuitry (SCKFEN should be cleared).

8.3.2. Watchdog Timer Failure

In the event of a Watchdog Timer Oscillator (WTO) failure, a similar nonmaskable interrupt-like event is issued. This event does not trigger an attendant clock switch-over, but alerts the CPU of the failure. After a Watchdog Timer failure, it is no longer possible to detect a System Clock failure. The failure detection circuitry does not function if the Watchdog Timer is used as the System Clock. In this case, it is necessary to disable the detection circuitry by clearing WTOFEN.

The WTO failure-detection circuit counts system clocks while looking for a Watchdog Timer clock. The logic counts 8004 system clock cycles before determining that a failure has occurred. The system clock rate determines the speed at which the Watchdog Timer failure can be detected. A very slow system clock results in very slow detection times.

8.4. High Frequency Crystal Oscillator

The products in the F6482 Series contain an on-chip High Frequency Crystal Oscillator (HFXO) for use with external crystals with 1 MHz to 24 MHz frequencies. HFXO features include:

- Optimized for low current consumption
- Selectable as System Clock
- Selectable as the PLL reference clock, which in turn, can generate System Clock and/or generate clocking for the USB

Alternatively, the X_{IN} input pin can also accept a 1 MHz–24 MHz CMOS-level clock input signal. If an external clock generator is used, the X_{OUT} pin must be left unconnected.

► **Note:** Although the X_{IN} pin can be used as an main system clock input for an external clock generator, configuring PA0 as CLKIN is better suited for such use. To learn more, see the [System Clock Selection](#) section on page 98).

8.4.1. Operating Modes

The HFXO and external clock drive support three frequency bands:

- Low gain for use with medium frequency crystals, ceramic resonators or external clock drive (1 MHz to 8 MHz)
- Medium gain for use with medium frequency crystals, ceramic resonators or external clock drive (> 8 MHz to 16 MHz)
- Maximum gain for use with high-frequency crystals or external clock drive (> 16 MHz to 24 MHz)

The HFXO and external clock drive band is selected using HXFOBAND in the CLKCTL2 Register.

8.4.2. HFXO Operation

HFXOEN in the CLKCTL2 Register controls whether the HFXO is enabled. During System Reset, HFXOEN is cleared, disabling the HFXO. When user code sets HFXOEN to enable the crystal oscillator, it should also check that the HFXO is stable, by reading HFXORDY, before using it as the PLL clock source or selecting the HFXO as System Clock. HFXORDY is cleared when the HFXO is disabled.

Figure 12 shows a recommended configuration for connection with external load capacitors and a fundamental-mode, parallel-resonant crystal operating. See the [Electrical Characteristics](#) chapter on page 601 for additional details regarding the characteristics of the HFXO. Printed circuit board layout should minimize crystal pin parasitic capacitance.

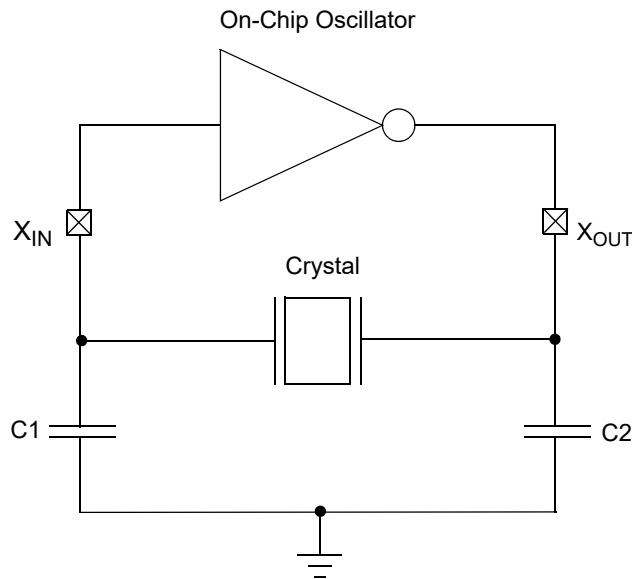

Figure 12. Recommended 16MHz Crystal Oscillator Configuration

8.5. Low Frequency Crystal Oscillator

The products in the F6482 Series contain a low-frequency on-chip crystal oscillator (LFXO) for use with an external 32.768kHz crystal. LFXO features include:

- Optimized for low current consumption
- Selectable as PCLK which can clock peripherals and be used to generate System Clock

Alternatively, the X2_{IN} input pin can also accept a 32.768kHz CMOS-level clock input signal. If an external clock generator is used, the X2_{OUT} pin must be left unconnected.

8.5.1. LFXO Operation

LFXOEN in the CLKCTL1 Register controls whether the LFXO is enabled. During System Reset, LFXOEN is cleared, disabling the LFXO.

Figure 13 shows a recommended configuration for connection with external load capacitors a fundamental-mode, parallel-resonant crystal operating. See the [Electrical Characteristics](#) chapter on page 601 for additional details regarding the characteristics of the LFXO. Printed circuit board layout should minimize crystal pin parasitic capacitance.

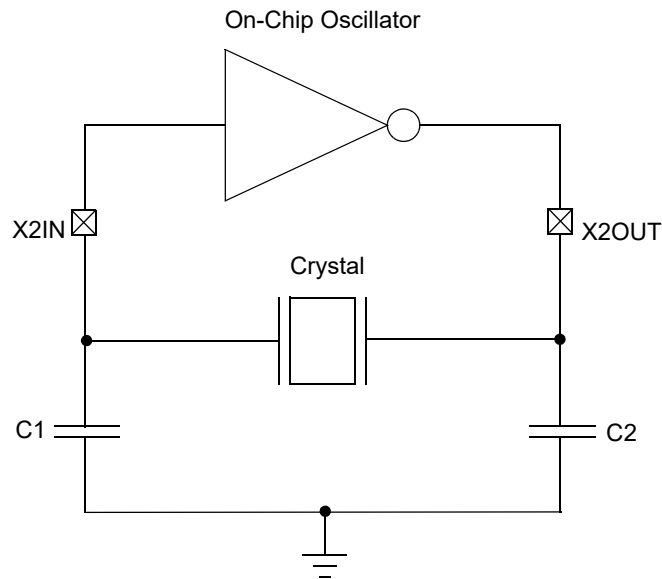

Figure 13. Recommended 32.768kHz Crystal Oscillator Configuration

8.6. Internal Precision Oscillator

The Internal Precision Oscillator (IPO) can be selected as PCLK and is designed for use without external components. IPO features include:

- On-chip RC oscillator that does not require external components
- Elimination of crystals in applications for which high timing accuracy is not required
- 32.768kHz nominal frequency
- Accuracy: $\pm 2\%$ over operational temperature and voltage range

8.6.1. Operation

IPOEN in the CLKCTL1 Register controls whether the IPO is enabled. During System Reset, IPOEN is set, enabling the IPO. If the IPO is disabled, user code can set IPOEN to enable the IPO, it should also check that the IPO is stable, by reading IPORDY, before selecting the IPO as PCLK.

The IPO is an RC relaxation oscillator that offers low sensitivity to power supply and temperature variation. At System Reset, the IPO is enabled and selected as PCLK which, in turn, is selected as input to the FLL. If the IPO is not required, it can be disabled by clearing IPOEN in CLKCTL1 to reduce system power consumption.

8.7. Watchdog Timer Oscillator

The Watchdog Timer Oscillator (WTO) can be selected as System Clock, the clock source for several peripheral, and is the clock source for the Watchdog Timer. The WTO is automatically enabled whenever it is needed.

8.8. Digitally Controlled Oscillator

The Digitally Controlled Oscillator (DCO) can be selected as System Clock and can be adjusted to oscillate over a wide frequency range. DCO features include:

- Can be locked to PCLK using the FLL or can free run
- When free running, the oscillation frequency is adjusted via the DCO control words, DCOCTLH and DCOCTL
- When using the FLL, the DCO is locked to a multiple of PCLK determined by FLLNDIVL and FLLNDIVH
- When locked, the FLL can remain enabled so that the DCO control words continue to converge, tracking any changes in operating conditions, or the FLL can be disabled to free run with the current DCO control words
- The converged DCO control words can be saved for later use in rapid frequency changing

8.8.1. Operating Modes

The DCO supports two operating modes:

- Free running (FLEN = 0 in CLKCTL5)
- Locked to PCLK using the FLL (FLEN = 1 in CLKCTL5)

8.8.2. DCO Operation

DCOEN in the CLKCTL5 Register controls whether the DCO is enabled. During System Reset, DCOEN is set, enabling the DCO. After setting DCOEN to enable the DCO, the DCO will oscillate at a frequency determined by the DCO control words as well as device characteristics and operating conditions. A particular set of DCO control words may not provide exactly the same oscillation frequency on all units, or at differing operating conditions for any particular unit.

To achieve a desired DCO operating frequency, the appropriate control word values for a particular unit at its current operating conditions can be determined by enabling the FLL to lock the DCO to PCLK. FLLRDY will be set after the convergence of the DCO control words is completed. The FLL can remain enabled so that the DCO control words continue

to converge to track any changes in operating conditions, or the FLL can be disabled to run with the current DCO control words.

The converged DCO control words, DCOCTLCL and DCOCTLCH, for a particular frequency can be saved for later use in rapid frequency changes by writing the saved values to the DCO control words, DCOCTL and DCOCTLH. While the FLL is disabled (FLEN = 0), to rapidly switch the DCO from its current frequency to a previously saved, converged frequency, observe the following procedure:

1. Set SEEDSEL=1 so that the DCO responds to the DCOCTL/DCOCTLH registers.
2. Write the value stored from DCOCTLCL to DCOCTL. The new DCOCTL value will not be applied to the DCO until DCOCTLH is written
3. Write the value stored from DCOCTLCH to DCOCTLH. Writing DCOCTLH applies both DCOCTL and DCOCTLH to the DCO.

To learn more about changing DCO frequency while the FLL is enabled, see the [Frequency Locked Loop](#) section on page 109.

Use caution when free running the DCO, as changes to operating temperature and operating voltage can result in a DCO frequency that differs from the frequency at the time the DCO control word values were converged.

8.9. Frequency Locked Loop

The Frequency Locked Loop (FLL) is used to lock the DCO to a frequency multiple of PCLK. FLL features include:

- Converges DCO control words to achieve frequency lock
- Employs both fast locking and linear locking algorithms
- Locks with or without stored values (seed) for the DCO control words

8.9.1. Operating Modes

The FLL supports two locking modes:

- A fast locking algorithm is initiated when FLLDIVH is written and SEEDSEL = 0. It is well-suited to locking without initial values (seed) for the DCO control words. The fast locking algorithm is also initiated automatically during a System Reset.
- A linear locking algorithm is initiated when FLLDIVH is written and SEEDSEL = 1. It is well-suited to locking to available values (seed) for the DCO control words. The linear locking algorithm is also initiated whenever FLEN is set.

8.9.2. FLL Operation

The FLL consists of a 10-bit feedback divider, a phase detector and an integrator. A block diagram of the FLL with connections to the DCO is shown in Figure 14.

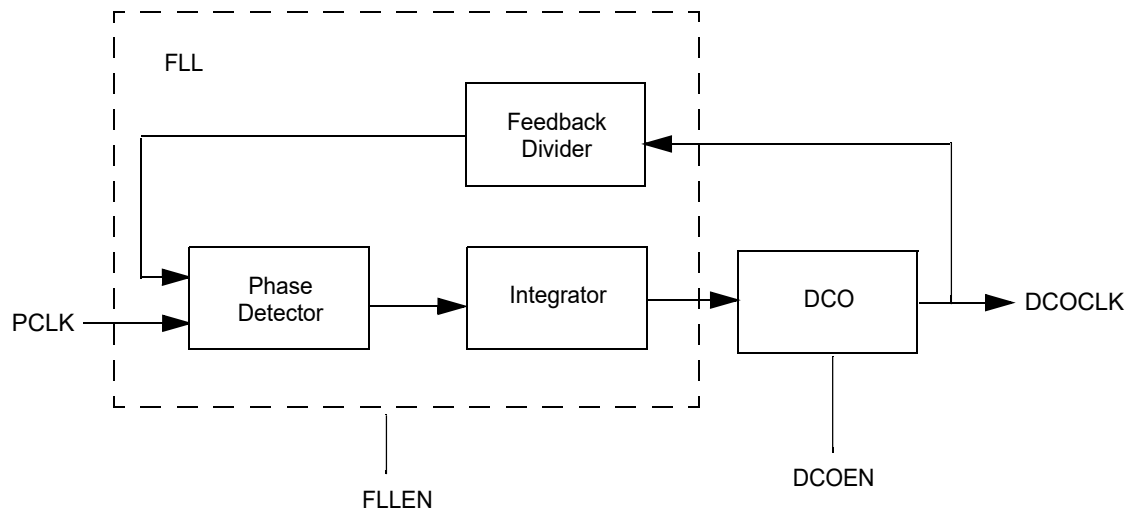

Figure 14. FLL Block Diagram

FLEN in the CLKCTL5 Register controls whether the FLL is enabled. During System Reset, FLEN is cleared, disabling the FLL such that the DCO is free-running at a relatively low nominal frequency (approximately 0.8MHz). While enabled, the FLL converges the DCO control words to lock the DCO to the multiple of PCLK determined by {FLLDIVH, FLLDIVL}. The FLL satisfies the following equation:

$$\text{DCOCLK} = \text{PCLK} \times \{\text{FLLDIVH}, \text{FLLDIVL}\}$$

The converged DCO control word values for a given DCO frequency can be stored for later use in rapid DCO frequency changes as described in the [Digitally Controlled Oscillator](#) section on page 108.

A change of FLL frequency target can be initiated without or with a stored values for the DCO control word:

- If there are no desired stored values for the DCO control words, and if any previous fast lock activity is completed, new DCO control word values can be converged using a fast locking algorithm. To initiate the fast locking algorithm, observe the following procedure:
 - a. Set SEEDSEL = 0 to indicate that the existing DCO control words should not be used during the locking process. Also set FLEN=1.

- b. Write FLLNDIVL with the least significant byte of the desired frequency divisor.
 - c. Write FLLNDIVH with the most significant byte of the desired frequency divisor. Writing to FLLNDIVH will trigger the fast locking algorithm.
- If stored values for the DCO control words are available, They can be used to seed FLL convergence using a linear locking algorithm. To initiate the linear locking algorithm, observe the following procedure:
 - a. Set SEEDSEL = 1 to indicate that loaded values for the DCO control words should be used during the locking process. Also set FLLLEN=1.
 - b. Write the value stored from DCOCTLCL to DCOCTL.
 - c. Write the value stored from DCOCTLCH to DCOCTLH.
 - d. Write FLLNDIVL with the least significant byte of the desired frequency divisor.
 - e. Write FLLNDIVH with the most significant byte of the desired frequency divisor. Writing to FLLNDIVH will trigger the linear locking algorithm.

Three bits, FLLRDY, FLLLL, and FLADONE, are provided in the CLKCTL5 Register to describe the FLL status. When the FLL has achieved lock status, FLLRDY is set. If the FLL loses lock status, FLLLL is set, and FLLRDY is cleared. If the FLL is disabled, both FLLRDY and FLLLL are cleared. If the lock is lost while the FLL is enabled, a system clock fail trap occurs if the FLLIRQE bit in the CLKCTL5 Register is set. The FLADONE bit is set when the fast locking algorithm has completed. The setting of the FLLRDY bit precedes the setting of FLADONE.

► **Note:** The fast locking algorithm should not be interrupted by entering Stop Mode, clearing the FLLLEN bit, or by changing the FLL divider value. After the fast locking algorithm has been initiated, always check to determine that it has completed (as evidenced by FLADONE = 1) before entering Stop Mode, clearing the FLLLEN bit, or by changing the FLL divider value. The fast locking algorithm is always initiated automatically during System Reset.

While the FLL is enabled, it continues to converge the DCO control codes, as required, to maintain frequency lock. Although the DCO has fine resolution, the resolution is finite and the FLL operation can result in dithering between two values of the DCO control words. If such dither is undesirable, the FLL can be disabled for dither-free operation and enabled periodically to again converge the DCO control words and therefore account for environmental changes. Upon being enabled, the FLL will converge the DCO control words based on the divisor values in FLLNDIVL and FLLNDIVH, achieve lock using the linear algorithm, and set FLLRDY.

Immediately after Stop-Mode Recovery, the DCO is enabled and operates with the DCO control words existing upon entry into Stop Mode. In addition, the FLL is disabled and

FLLRDY is cleared. If no frequency change is desired, the FLL can be enabled and will lock using the linear algorithm. When locked, FLLRDY will be set.

8.10. Phase Locked Loop

The Phase Locked Loop (PLL) can be used to generate PLLCLK which can be used as System Clock and/or to clock the USB. The HFXO or external clock drive can serve as the reference for the PLL. PLL features include:

- Fully integrated PLL
- Programmable input, feedback and output dividers
- Provides an accurate, low jitter clock suitable for USB applications
- PLL ready flag

8.10.1. Operation

The PLL consists of an input clock multiplexer, a 4-bit reference divider, the PLL core including a Voltage Controlled Oscillator (VCO), a 3-bit output divider and a 8-bit feedback divider. A block diagram of the PLL is shown in Figure 15.

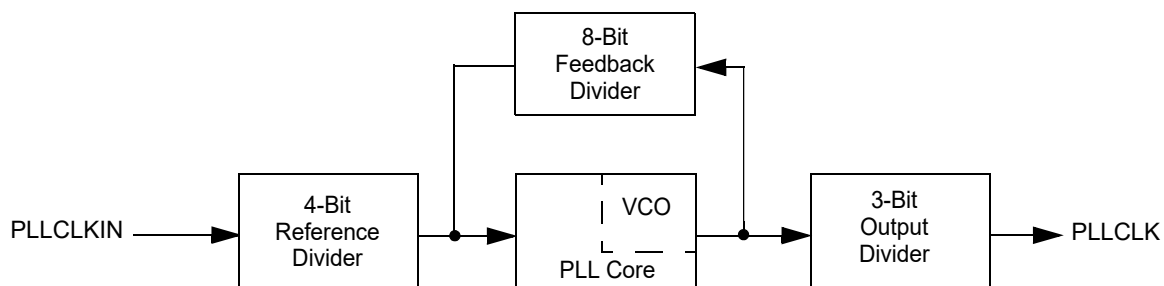

Figure 15. PLL Block Diagram

PLLEN in the CLKCTL Register controls whether the PLL is enabled. During System Reset, PLLEN is cleared, disabling the PLL. Before setting PLLEN to enable the PLL, user software should check that the PLL clock source is stable. Prior to enabling the USB or selecting the PLL as a system clock, user software should check that the PLL is ready by reading PLLRDY.

The input clock selection is controlled by PLLSEL in CLKCTL which can select either the HXFO or External Clock Drive as input to the 4-bit reference divider that ultimately provides the reference clock input to the PLL core. The reference divider prescales the input clock and is controlled by PLLRDIV in CLKCTLB.

Frequency multiplication is determined by the 8-bit feedback divider which is controlled by PLLNDIV in CLKCTLA. Disable the PLL prior to changing PLLRDIV or PLLNDIV, then again enable the PLL. The result can be reduced in frequency using the 3-bit output divider controlled by PLLDIV in CLKCTLB. The PLL satisfies the following equation:

$$PLL_{CLK} = \frac{PLL_{CLKIN}}{(PLLRDIV + 1)} \times \frac{(PLLNDIV + 1)}{(PLLODIV + 1)}$$

The operands in the above equation can be defined as:

- PLL_{CLKIN} is either HFXO or the External Clock Drive, as selected by the PLLSEL
- PLL_{RDIV} + 1 is the PLL reference divider ratio
- PLL_{NDIV} + 1 is the PLL feedback divider ratio
- PLL_{ODIV} + 1 is the PLL output divider ratio

The PLL should be configured in accordance with the following requirements:

- PLL_{CLKIN}: 0.3125MHz–24MHz
- Reference divider output frequency (PLL core input clock): 0.3125–24MHz, 1.5MHz – the recommended minimum for when clocking the USB
- PLL VCO frequency (input to output divider): 80MHz–384MHz
- PLL_{CLK} (PLL output): 48MHz max. If PLL_{CLK} is >25MHz and is selected as the source for System Clock, SCKDIV must be configured such that System Clock does not exceed 24MHz.

Table 37 lists common PLL configurations to generate a 48MHz PLL_{CLK} for the USB that satisfy the 2500ppm data rate requirement.

Table 37. Common PLL Configurations for 48MHz PLLCLK

PLL _{CLKIN} (MHz)	PLLRDIV	PLL Core (MHz)	PLL _{NDIV}	VCO (MHz)	PLL _{ODIV}
1.5	0	1.5	63	96	1
1.6	0	1.6	59	96	1
2	0	2	47	96	1
2.4	0	2.4	39	96	1
3	0	3	31	96	1
3.2	0	3.2	29	96	1
3.84	0	3.84	24	96	1
4	0	4	23	96	1

Table 37. Common PLL Configurations for 48MHz PLLCLK (Continued)

PLL _{CLKIN} (MHz)	PLL _{RDIV}	PLL Core (MHz)	PLL _{NDIV}	VCO (MHz)	PLL _{ODIV}
4.5	2	1.5	63	96	1
4.8	1	2.4	39	96	1
5	0	5	47	240	4
6	1	3	31	96	1
6.4	2	2.133333	44	96	1
7.2	2	2.4	39	96	1
8	0	8	11	96	1
9	2	3	31	96	1
9.6	0	9.6	9	96	1
10	1	5	47	240	4
12	0	12	7	96	1
12.8	1	6.4	14	96	1
14.4	2	4.8	19	96	1
16	0	16	5	96	1
18	2	6	15	96	1
19.2	0	19.2	4	96	1
20	3	5	47	240	4
24	0	24	3	96	1

To avoid spurious PLL_{CLK} behavior when modifying PLLh divider ratios, write CLKCTLA and CLKCTLB only when the PLL is disabled.

8.11. Clock System Register Definitions

The Clock System registers enable and disable the various oscillator circuits, enable and disable the failure detection and recovery circuitry, and select clock sources for System Clock, Peripheral Clock, and PLL clock.

8.11.1. Clock Control 0 Register

The Clock Control 0 (CLKCTL0) Register, shown in Table 38, selects System Clock and System Clock division, enables/disables System Clock failure detection, and provides clock system register locking status and control. SCKSEL is reset by both System Reset and Stop-Mode Recovery.

Before writing CLKCTL0, the clock control registers must be unlocked as described in the [Clock System Control Register Unlocking/Locking](#) section on page 103.

Table 38. Clock Control 0 Register (CLKCTL0)

Bit	7	6	5	4	3	2	1	0
Field	CSTAT	SCKFEN	SCKDIV			SCKSEL		
Reset	0	0	0	0	0	0	0	0
SMR*	none	none	none	none	none	0	0	0
R/W	R/W0	R/W	R/W	R/W	R/W	R/W	R/W	R/W
Address	F82h							
Note: *SMR = Effect of Stop-Mode Recovery.								

Bit	Description
[7] CSTAT	<p>Clock System Register Lock Status</p> <p>0: Clock system registers are locked. User software can clear CSTAT to lock the clock system registers.</p> <p>1: Clock system registers are unlocked. Set by hardware when the {E7h, 18h} unlock sequence is written to CLKCTL0. To remain unlocked when writing to CLKCTL0, the byte written to CLKCTL0 must have CSTAT set.</p>
[6] SCKFEN	<p>System Clock Failure Detection Enable</p> <p>0: Failure detection of the System Clock is disabled.</p> <p>1: Failure detection of the System Clock is enabled.</p>
[5:3] SCKDIV	<p>System Clock Division Ratio</p> <p>000: 1.</p> <p>001: 2.</p> <p>010: 3.</p> <p>011: 4.</p> <p>100: 6.</p> <p>101: 8. This setting should not be used if the System Clock frequency is $\leq 12\text{kHz}$ (e.g., WTO is selected as System Clock) and SCKFEN is set.</p> <p>110: 16. This setting should not be used if the System Clock frequency is $\leq 24\text{kHz}$ (e.g., WTO is selected as System Clock) and SCKFEN is set.</p> <p>111: 32. This setting should not be used if the System Clock frequency is $\leq 48\text{kHz}$ (e.g., PCLK or WTO is selected as System Clock) and SCKFEN is set.</p>

Bit	Description (Continued)
[2:0]	System Clock Source Select
SCKSEL	There is a delay from the writing of SCKSEL to the actual switching from the currently active clock source to the new, desired clock source. Reading SCKSEL return the currently active clock source. 000: Digitally Controlled Oscillator (DCO). 001: Peripheral Clock (PCLK). 010: High Frequency Crystal Oscillator (HFXO) or external clock drive, CLKIN on PA0, based on PLL Clock Source Select (PLLSEL). 011: Phase Locked Loop (PLL). 100: Watchdog Timer Oscillator (WTO). 101: Reserved. 110: Reserved. 111: Reserved.

8.11.2. Clock Control 1 Register

The Clock Control 1 (CLKCTL1) Register, shown in Table 39, enables/disables the IPO and LFXO, selects PCLK Stop Mode behavior, selects the PCLK source, enables/disables WTO failure detection, and contains a ready bit for the IPO. Before writing CLKCTL1, the clock control registers must be unlocked as described in the [Clock System Control Register Unlocking/Locking](#) section on page 103.

Table 39. Clock Control 1 Register (CLKCTL1)

Bit	7	6	5	4	3	2	1	0
Field	IPORDY	Reserved	WTOFEN	PCKSEL		PCKSM	LFXOEN	IPOEN
Reset	0	0	0	0	0	0	0	1
R/W	R	R	R/W	R/W	R/W	R/W	R/W	R/W
Address	F83h							

Bit	Description
[7]	Internal Precision Oscillator (IPO) Ready Flag
IPORDY	0: The IPO is not ready. 1: The IPO is ready.
[6]	Reserved This bit is reserved and must be programmed to 0.
[5]	Watchdog Timer Oscillator Failure Detection Enable
WTOFEN	0: Failure detection of Watchdog Timer Oscillator is disabled. 1: Failure detection of Watchdog Timer Oscillator is enabled.

Bit	Description (Continued)
[4:3] PCKSEL	PCLK Source Select There is a delay from the writing of PCKSEL to the actual switching from the currently active clock source to the new, desired clock source. Reading PCKSEL returns the currently active clock source. 00: Internal Precision Oscillator (IPO). 01: Low Frequency Crystal Oscillator (LFXO). 10: External clock drive, CLK2IN on PA2. 11: Reserved.
[2] PCKSM	PCLK Stop Mode Operation 0: Enabled PCLK sources do not operate during Stop Mode. 1: Enabled PCLK source operate during Stop Mode. To enable Internal Precision Oscillator operation during Stop Mode, it is also necessary to set FRECOV in the Power Control 0 Register.
[1] LFXOEN	Low Frequency Crystal Oscillator (LFXO) Enable 0: LFXO is disabled. 1: LFXO is enabled.
[0] IPOEN	Internal Precision Oscillator (IPO) Enable 0: IPO is disabled. 1: IPO is enabled.

8.11.3. Clock Control 2 Register

The Clock Control 2 (CLKCTL2) Register, shown in Table 40, enables/disables the HFXO, selects the HFXO frequency band and contains the HFXO ready flag. Before writing CLKCTL2, the clock control registers must be unlocked as described in the [Clock System Control Register Unlocking/Locking](#) section on page 103.

Table 40. Clock Control 2 Register (CLKCTL2)

Bit	7	6	5	4	3	2	1	0
Field	HFXORDY	Reserved			HFXOBAND		Reserved	HFXOEN
Reset	0	0	0	0	0	0	0	0
R/W	R	R	R	R	R/W	R/W	R/W	R/W
Address	F84h							

Bit	Description
[7] HFXORDY	High Frequency Crystal Oscillator (HFXO) Ready Flag 0: The HFXO is not ready. 1: The HFXO is ready.
[6:4]	Reserved These bits are reserved and must be programmed to 000.

Bit	Description (Continued)
[3:2] HFXOBAND	High Frequency Crystal Oscillator (HFXO) Frequency Band 00: The HFXO or external clock drive is in the 1MHz to 8MHz frequency band. 01: The HFXO or external clock drive is in the > 8MHz to 16MHz frequency band. 10: The HFXO or external clock drive is in the > 16MHz to 24MHz frequency band. 11: Reserved.
[1]	Reserved This bit is reserved and must be programmed to 0.
[0] HFXOEN	High Frequency Crystal Oscillator (HFXO) Enable 0: HFXO is disabled. 1: HFXO is enabled. In Stop Mode, this bit is overridden such that the HFXO is disabled.

8.11.4. Clock Control 3 Register

The Clock Control 3 (CLKCTL3) Register, shown in Table 41, selects the FLL N-Divider High byte. Before writing CLKCTL3, the clock control registers must be unlocked as described in the [Clock System Control Register Unlocking/Locking](#) section on page 103.

Table 41. Clock Control 3 Register (CLKCTL3)

Bit	7	6	5	4	3	2	1	0
Field	FLLNDIVH							
Reset	0	0	0	0	1	0	0	0
R/W	R/W	R/W	R/W	R/W	R/W	R/W	R/W	R/W
Address	F85h							

Bit Description

[7:0] **Frequency Locked Loop (FLL) N-Divider High Byte**
 FLLNDIVH The most significant bits of the FLL N-divider control word, bits 9:2. Refer to the [Clock Control 4 Register](#) section on page 119 to learn more about FLL N-divider settings.

8.11.5. Clock Control 4 Register

The Clock Control 4 Register (CLKCTL4) selects the FLL N-Divider Low byte. Before writing CLKCTL4, the clock control registers must be unlocked as described in the [Clock System Control Register Unlocking/Locking](#) section on page 103.

Table 42. Clock Control 4 Register (CLKCTL4)

Bit	7	6	5	4	3	2	1	0
Field	Reserved						FLLNDIVL	
Reset	0	0	0	0	0	0	0	0
R/W	R	R	R	R	R	R	R/W	R/W
Address	F86h							

Bit Description

[7:2] **Reserved**
 These bits are reserved and must be programmed to 000000.

Bit	Description (Continued)
[1:0]	Frequency Locked Loop (FLL) N-Divider Low Byte
FLLNDIVL	00–11: Least significant bits of the FLL N-divider control word, bits 1:0. To meet minimum and maximum FLL operating frequency requirements, {FLLNDIVH, FLLNDIVL} should not be less than 01Fh (1MHz) nor exceed 2DCh (24MHz). {FLLNDIVH, FLLNDIV} function as follows: 000h–01Eh=Reserved, 01Fh=Multiply PCLK by 31. 020h=Multiply PCLK by 32. 021h=Multiply PCLK by 33. . . . 2DAh: Multiply PCLK by 730. 2DBh: Multiply PCLK by 731. 2DCh: Multiply PCLK by 732. 2FBh–3FFh: Reserved.

8.11.6. Clock Control 5 Register

The Clock Control 5 Register (CLKCTL5), shown in Table 43, enables/disables various clock sources and selects controls the DCO and FLL. Entry into Stop Mode and Stop-Mode Recovery (SMR) affects the state of some bits in this register and leaves others unchanged. Before writing CLKCTL5, the clock control registers must be unlocked as described in the [Clock System Control Register Unlocking/Locking](#) section on page 103.

Table 43. Clock Control 5 Register (CLKCTL5)

Bit	7	6	5	4	3	2	1	0
Field	Reserved	FLLIRQE	FLLLL	FLLRDY	FLADONE	DCOEN	SEEDSEL	FLEN
Reset	0	0	0	0	0	1	0	0
STOP*	no change	no change	0	0	no change	0	no change	0
SMR*	no change	no change	0	0	no change	1	no change	0
R/W	R	R/W	R	R	R	R/W	R/W	R/W
Address	F87h							
Notes: *STOP = Effect of entering Stop Mode; SMR = Effect of Stop-Mode Recovery.								

Bit	Description
[7]	Reserved This bit is reserved and must be programmed to 0.

Bit	Description (Continued)
[6] FLLIRQE	FLL Lost Lock Interrupt Request Enable 0: The FLL lost lock condition (FLLLL) does not generate an interrupt request. 1: The FLL lost lock condition (FLLLL) generates an interrupt request using the System Clock failure interrupt.
[5] FLLLL	FLL Lost Lock 0: The FLL has not lost lock. 1: The FLL has lost lock.
[4] FLLRDY	FLL Ready 0: The FLL is not ready (unlocked). 1: The FLL is ready (locked).
[3] FLADONE	FLL Fast Locking Algorithm Done 0: The FLL fast locking algorithm is not done. If the fast locking algorithm was initiated, do not enter Stop Mode, clear FLEEN or change FLL divider value until this bit is set. 1: The FLL fast locking algorithm is done.
[2] DCOEN	Digitally Controlled Oscillator (DCO) Enable 0: DCO is disabled. 1: DCO is enabled.
[1] SEEDSEL	DCO Seed Select 0: DCO seed is internally computed when locking the FLL. 1: DCO seed is taken from DCOCTLH and DCOCTL. Typically, this setting is only used if the value of previously converged DCO control words will be written to DCOCTLH and DCOCTL.
[0] FLEEN	Frequency Locked Loop (FLL) Enable 0: FLL is disabled. The FLLRDY and FLLLL status bits are cleared when the FLL is disabled. 1: FLL is enabled.

8.11.7. Clock Control 6 Register

The Clock Control 6 (CLKCTL6) Register, shown in Table 44, selects the High byte of the DCO control word. This register can be written to a previously converged DCO control value for quick operating frequency changes. Before writing CLKCTL6, the clock control registers must be unlocked as described in the [Clock System Control Register Unlocking/Locking](#) section on page 103.

Table 44. Clock Control 6 Register (CLKCTL6)

Bit	7	6	5	4	3	2	1	0
Field	DCOCTLH							
Reset	0	0	0	0	0	0	0	0
R/W	R/W	R/W	R/W	R/W	R/W	R/W	R/W	R/W
Address	F88h							

Bit	Description
[7:0] DCOCTLH	Digitally Controlled Oscillator (DCO) Control Word High Byte The most-significant bits of the DCO control word, bits 15:8.

8.11.8. Clock Control 7 Register

The Clock Control 7 (CLKCTL7) Register, shown in Table 45, selects the low byte of the DCO control word. This register can be written to a previously converged DCO control value for quick operating frequency changes. Before writing CLKCTL7, the Clock Control registers must be unlocked as described in the [Clock System Control Register Unlocking/Locking](#) section on page 103.

Table 45. Clock Control 7 Register (CLKCTL7)

Bit	7	6	5	4	3	2	1	0
Field	DCOCTL7							
Reset	0	0	0	0	0	0	0	0
R/W	R/W	R/W	R/W	R/W	R/W	R/W	R/W	R/W
Address	F89h							

Bit	Description
[7:0] DCOCTL7	Digitally Controlled Oscillator (DCO) Control Word Low Byte The least-significant bits of the DCO control word, bits 7:0. The DCOCTL7[7] Register is implemented but not used by the FLL, allowing for future capability expansion.

8.11.9. Clock Control 8 Register

The Clock Control 8 (CLKCTL8) Register, shown in Table 46, selects the High byte of the DCO converged control word. This word can be read and saved, then later written to DCOCTLH for fast frequency switching. Before writing CLKCTL8, the clock control registers must be unlocked as described in the [Clock System Control Register Unlocking/Locking](#) section on page 103.

Table 46. Clock Control 8 Register (CLKCTL8)

Bit	7	6	5	4	3	2	1	0
Field	DCOCTL8							
Reset	X	X	X	X	X	X	X	X
R/W	R	R	R	R	R	R	R	R
Address	F8Ah							

Bit	Description
[7:0]	Digitally Controlled Oscillator (DCO) Converged Control Word High Byte
DCOCTLCH	The most-significant bits of the DCO converged control word, bits 15:8.

8.11.10. Clock Control 9 Register

The Clock Control 9 (CLKCTL9) Register, shown in Table 47, selects the low byte of the DCO converged control word. This word can be read and saved, then later written to DCOCTLCL for fast frequency switching. Before writing CLKCTL9, the Clock Control registers must be unlocked as described in the [Clock System Control Register Unlocking/Locking](#) section on page 103.

Table 47. Clock Control 9 Register (CLKCTL9)

Bit	7	6	5	4	3	2	1	0
Field	DCOCTLCL							
Reset	X	X	X	X	X	X	X	X
R/W	R	R	R	R	R	R	R	R
Address	F8Bh							

Bit	Description
[7:0]	Digitally Controlled Oscillator (DCO) converged control word Low Byte
DCOCTLCL	The least-significant bits of the DCO converged control word, bits 7:0.

8.11.11. Clock Control A Register

The Clock Control A (CLKCTLA) Register, shown in Table 48, selects the PLL feedback divider (PLLNDIV) control word. Before writing CLKCTLA, the clock control registers must be unlocked as described in the [Clock System Control Register Unlocking/Locking](#) section on page 103.

Table 48. Clock Control A Register (CLKCTLA)

Bit	7	6	5	4	3	2	1	0
Field	PLLNDIV							
Reset	0	0	0	0	0	0	0	0
R/W	R/W	R/W	R/W	R/W	R/W	R/W	R/W	R/W
Address	F8Ch							



Bit	Description
[7:0]	Phase Locked Loop (PLL) Feedback Division Ratio
PLLNDIV	Disable the PLL by clearing PLEN prior to changing PLLNDIV. 00h: 1. 01h: 2. 02h: 3. 03h: 4. • • • FCh: 253. FDh: 254. FEh: 255. FFh: 256.

8.11.12. Clock Control B Register

The Clock Control B (CLKCTLB) Register, shown in Table 49, selects the PLL reference divider (PLLRDIV) and PLL output divider (PLLODIV) control words. Before writing CLKCTLB, the clock control registers must be unlocked as described in the [Clock System Control Register Unlocking/Locking](#) section on page 103.

Table 49. Clock Control B Register (CLKCTLB)

Bit	7	6	5	4	3	2	1	0
Field	PLLRDIV				Reserved	PLLODIV		
Reset	0	0	0	0	0	0	0	0
R/W	R/W	R/W	R/W	R/W	R	R/W	R/W	R/W
Address	F8Dh							

Bit	Description
[7:4]	Phase Locked Loop (PLL) Reference Division Ratio
PLLRDIV	Disable the PLL by clearing PLEN prior to changing PLLRDIV. 0000: 1 0001: 2 0010: 3 0011: 4 0100: 5 0101: 6 0110: 7 0111: 8 1000: 9 1001: 10 1010: 11 1011: 12 1100: 13 1101: 14 1110: 15 1111: 16
[3]	Reserved This bit is reserved and must be programmed to 0.
[2:0]	Phase Locked Loop (PLL) Output Division Ratio
PLLODIV	000: 1 001: 2 010: 3 011: 4 100: 5 101: 6 110: 7 111: 8

8.11.13. Clock Control C Register

The Clock Control C (CLKCTL C) Register, shown in Table 50, enables/disables the PLL, selects the PLL reference clock, and contains the PLL ready flag. Entry into Stop Mode and Stop-Mode Recovery (SMR) affects the state of some bits in this register. Before writing CLKCTL C, the clock control registers must be unlocked as described in the [Clock System Control Register Unlocking/Locking](#) section on page 103.

Table 50. Clock Control C Register (CLKCTL C)

Bit	7	6	5	4	3	2	1	0	
Field	PLLRDY	Reserved					PLLSEL	PLLEN	
Reset	0	0	0	0	0	0	0	0	
R/W	R	R	R	R	R	R	R/W	R/W	
Address	F8Eh								

Bit	Description
[7] PLLRDY	Phase Locked Loop (PLL) Ready Flag 0: The PLL is not ready. 1: The PLL is ready.
[6:2]	Reserved This bit is reserved and must be programmed to 0.
[1] PLLSEL	PLL Source Select 0: High Frequency Crystal Oscillator (HFXO). 1: External clock drive, CLKIN on PA0.
[0] PLLEN	Phased Locked Loop (PLL) Enable 0: PLL is disabled. 1: PLL is enabled.

Chapter 9. Interrupt Controller

The interrupt controller on the F6482 Series products prioritizes the interrupt requests from the on-chip peripherals and the GPIO port pins. The interrupt controller includes the following features:

- Forty-one interrupt sources using thirty unique interrupt vectors
 - 16 GPIO port pin interrupt sources (nine interrupt vectors are shared, see Table 51)
 - 25 on-chip peripheral interrupt sources (five interrupt vectors are shared, see Table 51)
- Flexible GPIO interrupts
 - Twelve selectable rising and falling edge GPIO interrupts
 - Four dual-edge interrupts
- Three levels of individually programmable interrupt priority
- WDT can be configured to generate an interrupt

Interrupt requests (IRQs) allow peripheral devices to suspend CPU operation in an orderly manner and force the CPU to start an interrupt service routine (ISR). Usually this interrupt service routine is involved with the exchange of data, status information, or control information between the CPU and the interrupting peripheral. When the service routine is completed, the CPU returns to the operation from which it was interrupted.

The eZ8 CPU supports both vectored and polled interrupt handling. For polled interrupts, the interrupt controller has no effect on operation. For more information about interrupt servicing by the eZ8 CPU, refer to the [eZ8 CPU Core User Manual \(UM0128\)](#), which is available free for download from the Zilog website.

9.1. Interrupt Vector Listing

Table 51 lists all of the interrupts available in order of priority. The interrupt vector is stored with the most-significant byte (MSB) at the even Program Memory address and the least-significant byte (LSB) at the following odd Program Memory address.

► **Note:** Some port interrupts are not available on the Z8Fxx82 64-pin package and the Z8Fxx81 32-pin package. The LCD, USB, SPI 1, Comparator 1, Multi-Channel Timer and UART 1 interrupt sources are unavailable on devices not containing those peripherals.

Table 51. Trap and Interrupt Vectors in Order of Priority

Priority*	Program Memory Vector Address	Interrupt or Trap Source
Highest	0002h	Reset (not an interrupt)
	0004h	Watchdog Timer; see the Watchdog Timer chapter on page 206
	0048h	System Clock Fail Trap (not an interrupt, the Clock System chapter on page 96)
	004Ah	Watchdog Timer Oscillator Fail Trap (not an interrupt, the Clock System chapter on page 96)
	0006h	Illegal Instruction Trap (not an interrupt)
	0008h	Timer 2
	000Ah	Timer 1
	000Ch	Timer 0
	000Eh	UART 0 receiver
	0010h	UART 0 transmitter
	0012h	USB
	0014h	USB Resume
	0016h	I ² C
	0018h	SPI 1
	001Ah	DAC
	001Ch	DMA1
	001Eh	DMA0
	0020h	ADC
	0022h	SPI 0
	0024h	LCD
	0026h	RTC
	0028h	Port A7, selectable rising or falling input edge or LVD. To learn more, see the Reset, Stop-Mode Recovery and Low-Voltage Detection chapter on page 38.

Table 51. Trap and Interrupt Vectors in Order of Priority (Continued)

Priority*	Program Memory Vector Address	Interrupt or Trap Source
	002Ah	Port A6, selectable rising or falling input edge or Comparator 0 Output, selectable rising or falling edge
	002Ch	Port A5, selectable rising or falling input edge or Comparator 1 Output, selectable rising or falling edge
	002Eh	Port A4 or Port D4, selectable rising or falling input edge
	0030h	Port A3 or Port D3, selectable rising or falling input edge
	0032h	Port A2 or Port D2, selectable rising or falling input edge
	0034h	Port A1 or Port D1, selectable rising or falling input edge
	0036h	Port A0, selectable rising or falling input edge
	0038h	AES
	003Ah	Multi-Channel Timer
	003Ch	UART 1 receiver
	003Eh	UART 1 transmitter
	0040h	Port C3, both input edges/DMA 3
	0042h	Port C2, both input edges/DMA 2
	0044h	Port C1, both input edges
Lowest	0046h	Port C0, both input edges

Note: *The order of priority is only for identical interrupt level. The priority varies depending on different interrupt level setting. See the [Interrupt Vectors and Priority](#) section on page 131 to learn more.

9.2. Architecture

Figure 16 shows the interrupt controller block diagram.

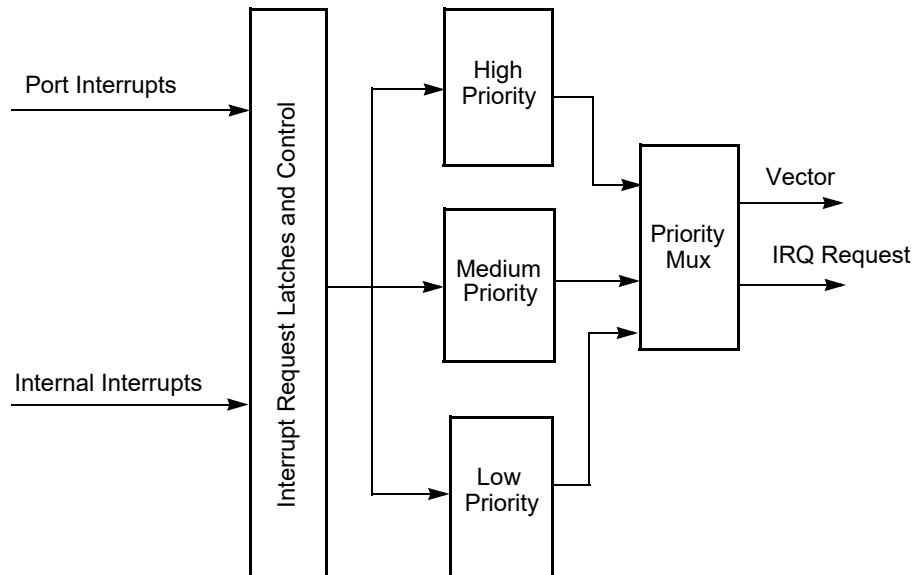

Figure 16. Interrupt Controller Block Diagram

9.3. Operation

The following section describes the master interrupt enable, interrupt vectors and priority, and interrupt assertion and deassertion.

9.3.1. Master Interrupt Enable

The master interrupt enable (IRQE) bit in the interrupt control register globally enables and disables interrupts.

Interrupts are globally enabled by any of the following actions:

- Execution of an Enable Interrupt (EI) instruction
- Execution of an Interrupt Return (IRET) instruction
- Writing 1 to the IRQE bit in the interrupt control register

Interrupts are globally disabled by any of the following actions:

- System Reset

- Stop-Mode Recovery
- Execution of a Disable Interrupt (DI) instruction
- Writing 0 to the IRQE bit in the interrupt control register
- eZ8 CPU acknowledgement of an interrupt service request from the interrupt controller
- Execution of a Trap instruction
- Illegal Instruction Trap
- Primary Oscillator Fail Trap
- Watchdog Oscillator Fail Trap

9.3.2. Interrupt Vectors and Priority

The interrupt controller supports three levels of interrupt priority. Level 3 is the highest priority, Level 2 is the second highest priority, and Level 1 is the lowest priority. If all of the interrupts are enabled with identical interrupt priority (for example, all as Level 2 interrupts), the interrupt priority is assigned from highest to lowest as specified in [Table 51 on page 128](#). Level 3 interrupts are always assigned higher priority than Level 2 interrupts which, in turn, always are assigned higher priority than Level 1 interrupts. Within each interrupt priority level (Level 1, Level 2, or Level 3), priority is assigned as specified in [Table 51 on page 128](#). Reset, Watchdog Timer interrupt (if enabled), Primary Oscillator Fail Trap, Watchdog Timer Oscillator Fail Trap, and Illegal Instruction Trap always have highest (Level 3) priority.

9.3.3. Interrupt Assertion

Interrupt sources assert their interrupt requests for only a single-system clock period (single pulse). When the interrupt request is acknowledged by the eZ8 CPU, the corresponding bit in the Interrupt Request Register is cleared until the next interrupt occurs. Writing 0 to the corresponding bit in the Interrupt Request Register likewise clears the interrupt request.



Caution: Zilog recommends not using a coding style that clears bits in the Interrupt Request registers. All incoming interrupts received between execution of the first LDX command and the final LDX command are lost. See Example 1, which follows.

Example 1. Poor coding style that can result in lost interrupt requests:

```
LDX r0, IRQ0
AND r0, MASK
LDX IRQ0, r0
```

To avoid missing interrupts, use the coding style in Example 2 to clear bits in the Interrupt Request 0 Register:

Example 2. Good coding style that avoids lost interrupt requests:

```
ANDX IRQ0, MASK
```

9.3.4. Software Interrupt Assertion

Program code can generate interrupts directly. Writing 1 to the correct bit in the Interrupt Request Register triggers an interrupt (assuming that interrupt is enabled). When the interrupt request is acknowledged by the eZ8 CPU, the bit in the Interrupt Request Register is automatically cleared to 0.



Caution: Zilog recommends not using a coding style to generate software interrupts by setting bits in the Interrupt Request registers. All incoming interrupts received between execution of the first LDX command and the final LDX command are lost. See Example 3, which follows.

Example 3. Poor coding style that can result in lost interrupt requests:

```
LDX r0, IRQ0  
OR r0, MASK  
LDX IRQ0, r0
```

To avoid missing interrupts, use the coding style in Example 4 to set bits in the Interrupt Request registers.

Example 4. Good coding style that avoids lost-interrupt requests:

```
ORX IRQ0, MASK
```

9.4. Interrupt Control Register Definitions

For all interrupts other than the Watchdog Timer interrupt, the Primary Oscillator Fail Trap, and the Watchdog Oscillator Fail Trap, the Interrupt Control registers enable individual interrupts, set interrupt priorities, and indicate interrupt requests.

9.4.1. Interrupt Request 0 Register

The Interrupt Request 0 (IRQ0) Register, shown in Table 52, stores the interrupt requests for both vectored and polled interrupts. When a request is presented to the interrupt controller, the corresponding bit in the IRQ0 Register becomes 1. If interrupts are globally enabled (vectored interrupts), the interrupt controller passes an interrupt request to the eZ8

CPU. If interrupts are globally disabled (polled interrupts), the eZ8 CPU can read the Interrupt Request 0 Register to determine if any interrupt requests are pending.

Table 52. Interrupt Request 0 Register (IRQ0)

Bit	7	6	5	4	3	2	1	0
Field	T2I	T1I	T0I	U0RXI	U0TXI	USBI	USBRI	I2CI
Reset	0	0	0	0	0	0	0	0
R/W	R/W	R/W	R/W	R/W	R/W	R/W	R/W	R/W
Address	FC0h							

Bit	Description
[7] T2I	Timer 2 Interrupt Request 0: No interrupt request is pending for Timer 2. 1: An interrupt request from Timer 2 is awaiting service.
[6] T1I	Timer 1 Interrupt Request 0: No interrupt request is pending for Timer 1. 1: An interrupt request from Timer 1 is awaiting service.
[5] T0I	Timer 0 Interrupt Request 0: No interrupt request is pending for Timer 0. 1: An interrupt request from Timer 0 is awaiting service.
[4] U0RXI	UART 0 Receiver Interrupt Request 0: No interrupt request is pending for the UART 0 receiver. 1: An interrupt request from the UART 0 receiver is awaiting service.
[3] U0TXI	UART 0 Transmitter Interrupt Request 0: No interrupt request is pending for the UART 0 transmitter. 1: An interrupt request from the UART 0 transmitter is awaiting service.
[2] USBI	USB Interrupt Request 0: No interrupt request is pending for the USB. 1: An interrupt request from the USB is awaiting service.
[1] USBRI	USB Resume Interrupt Request 0: No interrupt request is pending for USB Resume. 1: An interrupt request for USB Resume is awaiting service.
[0] I2CI	I²C Interrupt Request 0: No interrupt request is pending for the I ² C. 1: An interrupt request from I ² C is awaiting service.

9.4.2. Interrupt Request 1 Register

The Interrupt Request 1 (IRQ1) Register, shown in Table 53, stores interrupt requests for both vectored and polled interrupts. When a request is presented to the interrupt controller, the corresponding bit in the IRQ1 Register becomes 1. If interrupts are globally enabled (vectored interrupts), the interrupt controller passes an interrupt request to the eZ8 CPU. If interrupts are globally disabled (polled interrupts), the eZ8 CPU can read the Interrupt Request 1 Register to determine if any interrupt requests are pending.

Table 53. Interrupt Request 1 Register (IRQ1)

Bit	7	6	5	4	3	2	1	0
Field	SPI1I	DACI	DMA1I	DMA0I	ADCI	SPI0I	LCDI	RTCI
Reset	0	0	0	0	0	0	0	0
R/W	R/W	R/W	R/W	R/W	R/W	R/W	R/W	R/W
Address	FC3h							

Bit	Description
[7] SPI1I	SPI 1 Interrupt Request 0: No interrupt request is pending for the SPI 1. 1: An interrupt request from the SPI 1 is awaiting service.
[6] DACI	DAC Interrupt Request 0: No interrupt request is pending for the DAC. 1: An interrupt request from the DAC is awaiting service.
[5:4] DMAxI	DMAx Interrupt Request 0: No interrupt request is pending for DMA x. 1: An interrupt request from DMA x is awaiting service; x indicates the specific DMA number (0–1).
[3] ADCI	ADC Interrupt Request 0: No interrupt request is pending for the ADC. 1: An interrupt request from the ADC is awaiting service.
[2] SPI0I	SPI0 Interrupt Request 0: No interrupt request is pending for the SPI 0. 1: An interrupt request from the SPI 0 is awaiting service.
[1] LCDI	LCD Interrupt Request 0: No interrupt request is pending for the LCD. 1: An interrupt request from the LCD is awaiting service.
[0] RTCI	RTC Interrupt Request 0: No interrupt request is pending for the RTC. 1: An interrupt request from the RTC is awaiting service.



9.4.3. Interrupt Request 2 Register

The Interrupt Request 2 (IRQ2) Register, shown in Table 54, stores interrupt requests for both vectored and polled interrupts. When a request is presented to the interrupt controller, the corresponding bit in the IRQ2 Register becomes 1. If interrupts are globally enabled (vectored interrupts), the interrupt controller passes an interrupt request to the eZ8 CPU. If interrupts are globally disabled (polled interrupts), the eZ8 CPU can read the Interrupt Request 2 Register to determine if any interrupt requests are pending.

Table 54. Interrupt Request 2 Register (IRQ2)

Bit	7	6	5	4	3	2	1	0
Field	PA7VI	PA6CI	PA5CI	PAD4I	PAD3I	PAD2I	PAD1I	PA0I
Reset	0	0	0	0	0	0	0	0
R/W	R/W	R/W	R/W	R/W	R/W	R/W	R/W	R/W
Address	FC6h							

Bit	Description
[7] PA7VI	Port A7 or LVD Interrupt Request 0: No interrupt request is pending for GPIO Port A7 or LVD. 1: An interrupt request from GPIO Port A7 or LVD.
[6] PA6CI	Port A6 or Comparator 0 Interrupt Request 0: No interrupt request is pending for GPIO Port A6 or Comparator 0. 1: An interrupt request from GPIO Port A6 or Comparator 0.
[5] PA5CI	Port A5 or Comparator 1 Interrupt Request 0: No interrupt request is pending for GPIO Port A5 or Comparator 1. 1: An interrupt request from GPIO Port A5 or Comparator 1.
[4:1] PADxI	Port Ax or Port Dx Interrupt Request 0: No interrupt request is pending for GPIO Port Ax or Port Dx, x indicates the specific Port A or D number (4–1). 1: An interrupt request from GPIO Port Ax or Port Dx is awaiting service.
[0] PA0I	Port A0 Interrupt Request For a description of the interrupt source select feature, see the Shared Interrupt Select Register 0 section on page 146. 0: No interrupt request is pending for GPIO Port A0. 1: An interrupt request from GPIO Port A0 is awaiting service.

9.4.4. Interrupt Request 3 Register

The Interrupt Request 3 (IRQ3) Register, shown in Table 55, stores interrupt requests for both vectored and polled interrupts. When a request is presented to the interrupt controller, the corresponding bit in the IRQ3 Register becomes 1. If interrupts are globally enabled (vectored interrupts), the interrupt controller passes an interrupt request to the eZ8 CPU. If interrupts are globally disabled (polled interrupts), the eZ8 CPU can read the Interrupt Request 3 Register to determine if any interrupt requests are pending.

Table 55. Interrupt Request 3 Register (IRQ3)

Bit	7	6	5	4	3	2	1	0
Field	AESI	MCTI	U1RXI	U1TXI	PC3I/ DMA3I	PC2I/ DMA2I	PC1I	PC0I
Reset	0	0	0	0	0	0	0	0
R/W	R/W	R/W	R/W	R/W	R/W	R/W	R/W	R/W
Address	FC9h							

Bit	Description
[7] AESI	AES Interrupt Request 0: No interrupt request is pending for the AES. 1: An interrupt request from the AES is awaiting service.
[6] MCTI	Multi-Channel timer Interrupt Request 0: No interrupt request is pending for multi-channel timer. 1: An interrupt request from multi-channel timer is awaiting service.
[5] U1RXI	UART 1 Receiver Interrupt Request 0: No interrupt request is pending for the UART 1 receiver. 1: An interrupt request from the UART 1 receiver is awaiting service.
[4] U1TXI	UART 1 Transmitter Interrupt Request 0: No interrupt request is pending for the UART 1 transmitter. 1: An interrupt request from the UART 1 transmitter is awaiting service.
[3:2] PCxI/DMAxI	Port Cx or DMA x Interrupt Request 0: No interrupt request is pending for GPIO Port Cx or DMA x. 1: An interrupt request from GPIO Port Cx or DMA x is awaiting service; x indicates the specific GPIO Port C bit or DMA number (3–2).
[1:0] PCxI	Port C Pin x Interrupt Request 0: No interrupt request is pending for GPIO Port C pin x. 1: An interrupt request from GPIO Port C pin x is awaiting service; x indicates the specific GPIO Port C pin number (1–0).

9.4.5. IRQ0 Enable High and Low Bit Registers

Table 56 presents the priority control for IRQ0. The IRQ0 Enable High and Low Bit registers, shown in Tables 57 and 58, form a priority-encoded enabling for interrupts in the Interrupt Request 0 Register. Priority is generated by setting bits in each register.

Table 56. IRQ0 Enable and Priority Encoding

IRQ0ENH[x]	IRQ0ENL[x]	Priority	Description
0	0	Disabled	Disabled
0	1	Level 1	Low
1	0	Level 2	Nominal
1	1	Level 3	High

Note: x indicates register bits from 0–7.

Table 57. IRQ0 Enable High Bit Register (IRQ0ENH)

Bit	7	6	5	4	3	2	1	0
Field	T2ENH	T1ENH	T0ENH	U0RENH	U0TENH	USBENH	USBRENH	I2CENH
Reset	0	0	0	0	0	0	0	0
R/W	R/W	R/W	R/W	R/W	R/W	R/W	R/W	R/W
Address	FC1h							

Bit	Description
[7] T2ENH	Timer 2 Interrupt Request Enable High Bit
[6] T1ENH	Timer 1 Interrupt Request Enable High Bit
[5] T0ENH	Timer 0 Interrupt Request Enable High Bit
[4] U0RENH	UART 0 Receive Interrupt Request Enable High Bit
[3] U0TENH	UART 0 Transmit Interrupt Request Enable High Bit
[2] USBENH	USB Interrupt Request Enable High Bit

Bit	Description (Continued)
[1] USBRENH	USB Resume Interrupt Request Enable High Bit
[0] I2CENH	I ² C Interrupt Request Enable High Bit

Table 58. IRQ0 Enable Low Bit Register (IRQ0ENL)

Bit	7	6	5	4	3	2	1	0
Field	T2ENL	T1ENL	T0ENL	U0RENL	U0TENL	USBENL	USBRENL	I2CENL
Reset	0	0	0	0	0	0	0	0
R/W	R/W	R/W	R/W	R/W	R/W	R/W	R/W	R/W
Address	FC2h							

Bit	Description
[7] T2ENL	Timer 2 Interrupt Request Enable Low Bit
[6] T1ENL	Timer 1 Interrupt Request Enable Low Bit
[5] T0ENL	Timer 0 Interrupt Request Enable Low Bit
[4] U0RENL	UART 0 Receive Interrupt Request Enable Low Bit
[3] U0TENL	UART 0 Transmit Interrupt Request Enable Low Bit
[2] USBENL	USB Interrupt Request Enable Low Bit
[1] USBRENL	USB Resume Interrupt Request Enable Low Bit
[0] I2CENL	I ² C Interrupt Request Enable Low Bit

9.4.6. IRQ1 Enable High and Low Bit Registers

Table 59 lists the priority control for IRQ1. The IRQ1 Enable High and Low Bit registers, shown in Tables 60 and 61, form a priority-encoded enabling for interrupts in the Interrupt Request 1 Register. Priority is generated by setting bits in each register.

Table 59. IRQ1 Enable and Priority Encoding

IRQ1ENH[x]	IRQ1ENL[x]	Priority	Description
0	0	Disabled	Disabled
0	1	Level 1	Low
1	0	Level 2	Nominal
1	1	Level 3	High

Note: x indicates register bits from 0–7.

Table 60. IRQ1 Enable High Bit Register (IRQ1ENH)

Bit	7	6	5	4	3	2	1	0
Field	SPI1ENH	DACENH	DMA1ENH	DMA0ENH	ADCENH	SPI0ENH	LCDENH	RTCENH
Reset	0	0	0	0	0	0	0	0
R/W	R/W	R	R/W	R/W	R/W	R/W	R/W	R/W
Address	FC4h							

Bit	Description
[7] SPI1ENH	SPI 1 Interrupt Request Enable High Bit
[6] DACENH	DAC Interrupt Request Enable High Bit
[5:4] DMAxENH	DMAx Interrupt Request Enable High Bit x indicates the specific DMA bit (5–4).
[3] ADCENH	ADC Interrupt Request Enable High Bit
[2] SPI0ENH	SPI 0 Interrupt Request Enable High Bit
[1] LCDENH	LCD Interrupt Request Enable High Bit
[0] RTCENH	RTC Interrupt Request Enable High Bit

Table 61. IRQ1 Enable Low Bit Register (IRQ1ENL)

Bit	7	6	5	4	3	2	1	0
Field	SPI1ENL	DACENL	DMA1ENL	DMA0ENL	ADCENL	SPI0ENL	LCDENL	RTCENL
Reset	0	0	0	0	0	0	0	0
R/W	R/W	R	R/W	R/W	R/W	R/W	R/W	R/W
Address	FC5h							

Bit	Description
[7] SPI1ENL	SPI 1 Interrupt Request Enable Low Bit
[6] DACENL	DAC Interrupt Request Enable Low Bit
[5:4] DMAxENL	DMAx Interrupt Request Enable Low Bit x indicates the specific DMA bit (5–4).
[3] ADCENL	ADC Interrupt Request Enable Low Bit
[2] SPI0ENL	SPI 0 Interrupt Request Enable Low Bit
[1] LCDENL	LCD Interrupt Request Enable Low Bit
[0] RTCENL	RTC Interrupt Request Enable Low Bit

9.4.7. IRQ2 Enable High and Low Bit Registers

Table 62 lists the priority control for IRQ2. The IRQ2 Enable High and Low Bit registers, shown in Tables 63 and 64, form a priority-encoded enabling for interrupts in the Interrupt Request 2 Register. Priority is generated by setting bits in each register.

Table 62. IRQ2 Enable and Priority Encoding

IRQ2ENH[x]	IRQ2ENL[x]	Priority	Description
0	0	Disabled	Disabled
0	1	Level 1	Low
1	0	Level 2	Nominal
1	1	Level 3	High

Note: x indicates the register bits from 0–7.

Table 63. IRQ2 Enable High Bit Register (IRQ2ENH)

Bit	7	6	5	4	3	2	1	0
Field	PA7VENH	PA6C0ENH	PA5C1ENH	PAD4ENH	PAD3ENH	PAD2ENH	PAD1ENH	PA0ENH
Reset	0	0	0	0	0	0	0	0
R/W	R/W	R/W	R/W	R/W	R/W	R/W	R/W	R/W
Address	FC7h							

Bit	Description
[7] PA7VENH	Port A7 or LVD Interrupt Request Enable High Bit
[6] PA6C0ENH	Port A6 or Comparator 0 Interrupt Request Enable High Bit
[5] PA5C1ENH	Port A5 or Comparator 1 Interrupt Request Enable High Bit
[4:1] PADxENH	Port Ax or Port Dx Interrupt Request Enable High Bit x indicates the specific PAD bit (4–1). See Table 69 on page 146 for a selection of either Port A or Port D as the interrupt source.
[0] PA0ENH	Port A0 Interrupt Request Enable High Bit See Table 69 on page 146 for a selection of either Port A or Port D as the interrupt source.

Table 64. IRQ2 Enable Low Bit Register (IRQ2ENL)

Bit	7	6	5	4	3	2	1	0
Field	PA7VENL	PA6C0ENL	PA5C1ENL	PAD4ENL	PAD3ENL	PAD2ENL	PAD1ENL	PA0ENL
Reset	0	0	0	0	0	0	0	0
R/W	R/W	R/W	R/W	R/W	R/W	R/W	R/W	R/W
Address	FC8h							

Bit	Description
[7] PA7VENL	Port A7 or LVD Interrupt Request Enable Low Bit
[6] PA6C0ENL	Port A6 or Comparator 0 Interrupt Request Enable Low Bit
[5] PA5C1ENL	Port A5 or Comparator 1 Interrupt Request Enable Low Bit

Bit	Description (Continued)
[4:1] PADxENL	Port Ax or Port Dx Interrupt Request Enable Low Bit x indicates the specific PAD bit (4–1).
[0] PA0ENL	Port A0 Interrupt Request Enable Low Bit

9.4.8. IRQ3 Enable High and Low Bit Registers

Table 65 describes the priority control for IRQ3. The IRQ3 Enable High and Low Bit registers, shown in Tables 66 and 67, form a priority-encoded enabling for interrupts in the Interrupt Request 3 Register. Priority is generated by setting bits in each register.

Table 65. IRQ3 Enable and Priority Encoding

IRQ3ENH[x]	IRQ3ENL[x]	Priority	Description
0	0	Disabled	Disabled
0	1	Level 1	Low
1	0	Level 2	Nominal
1	1	Level 3	High

Note: x indicates register bits from 0–7.

Table 66. IRQ3 Enable High Bit Register (IRQ3ENH)

Bit	7	6	5	4	3	2	1	0
Field	AESENH	MCTENH	U1RENH	U1TENH	C3ENH/ DMA3ENH	C2ENH/ DMA2ENH	C1ENH	C0ENH
Reset	0	0	0	0	0	0	0	0
R/W	R/W	R/W	R/W	R/W	R/W	R/W	R/W	R/W
Address	FCAh							

Bit	Description
[7] AESENH	AES Interrupt Request Enable High Bit
[6] MCTENH	Multi-Channel Timer Interrupt Request Enable High Bit
[5] U1RENH	UART1 Receive Interrupt Request Enable High Bit



Bit	Description (Continued)
[4] U1TENH	UART1 Transmit Interrupt Request Enable High Bit
[3:2] CxENH/ DMAyENH	Port Cx or DMAy Interrupt Request Enable High Bit x indicates the specific Port C bit (3–2); y indicates the specific DMA bit (3–2).
[1:0] CxENH	Port Cx (x=0–1) Interrupt Request Enable High Bit x indicates the specific Port C bit (1–0).

Table 67. IRQ3 Enable Low Bit Register (IRQ3ENL)

Bit	7	6	5	4	3	2	1	0
Field	AESENL	MCTENL	U1RENL	U1TENL	C3ENL/ DMA3ENL	C2ENL/ DMA2ENL	C1ENL	C0ENL
Reset	0	0	0	0	0	0	0	0
R/W	R/W	R/W	R/W	R/W	R/W	R/W	R/W	R/W
Address	FCBh							

Bit	Description
[7] AESENL	AES Interrupt Request Enable Low Bit
[6] MCTENL	Multi-Channel Timer Interrupt Request Enable Low Bit
[5] U1RENL	UART1 Receive Interrupt Request Enable Low Bit
[4] U1TENL	UART1 Transmit Interrupt Request Enable Low Bit
[3:2] CxENL/ DMAyENL	Port Cx or DMAy Interrupt Request Enable Low Bit x indicates the specific Port C bit (3–2); y indicates the specific DMA bit (3–2).
[1:0] CxENL	Port Cx (x=0–1) Interrupt Request Enable Low Bit x indicates the specific Port C bit (1–0).

9.4.9. Interrupt Edge Select Register

The Interrupt Edge Select (IRQES) Register, shown in Table 68, determines whether an interrupt is generated for the rising edge or falling edge on the selected GPIO Port A or Port D input pin.

Table 68. Interrupt Edge Select Register (IRQES)

Bit	7	6	5	4	3	2	1	0
Field	IES7	IES6	IES5	IES4	IES3	IES2	IES1	IES0
Reset	0	0	0	0	0	0	0	0
R/W	R/W	R/W	R/W	R/W	R/W	R/W	R/W	R/W
Address	FCCh							

Bit	Description
[7:0]	Interrupt Edge Select x
IESx	0: An interrupt request is generated on the falling edge of the PAX input or PDx input or Comparator output. 1: An interrupt request is generated on the rising edge of the PAX input or PDx input or Comparator output.

Note: x indicates the specific GPIO port bit number (7–0).

9.4.10. Shared Interrupt Select Register 0

The Shared Interrupt Select 0 (IRQSS0) Register, shown in Table 69, determines the source of the PAD_xS interrupts. The Shared Interrupt Select Register selects between Port A and alternate sources for the individual interrupts.

Table 69. Shared Interrupt Select Register 0 (IRQSS0)

Bit	7	6	5	4	3	2	1	0
Field	PA7VS	PA6CS	PA5CS	PAD4S	PAD3S	PAD2S	PAD1S	Reserved
Reset	0	0	0	0	0	0	0	0
R/W	R/W	R/W	R/W	R/W	R/W	R/W	R/W	R/W
Address	FCDh							

Bit	Description
[7] PA7VS	PA7/LVD Selection 0: PA7 is used for the interrupt for PA7VS interrupt request. 1: The LVD is used for the interrupt for PA7VS interrupt request.
[6] PA6CS	PA6/Comparator 0 Selection 0: PA6 is used for the interrupt for PA6CS interrupt request. 1: The Comparator 0 is used for the interrupt for PA6CS interrupt request.
[5] PA5CS	PA5/Comparator 1 Selection 0: PA5 is used for the interrupt for PA5CS interrupt request. 1: The Comparator 1 is used for the interrupt for PA5CS interrupt request.
[4:1] PAD _x S	PAX/PD_x Selection x indicates the specific Port A bit number (4–1). 0: PAX is used for the interrupt for PAX/PD _x interrupt request. 1: PD _x is used for the interrupt for PAX/PD _x interrupt request.
[0]	Reserved This bit is reserved and must be programmed to 0.

9.4.11. Shared Interrupt Select Register 1

The Shared Interrupt Select 1 (IRQSS1) Register, shown in Table 70, determines the source of the PCDMAxS interrupts. The Shared Interrupt Select Register selects between Port C and DMA for the individual interrupts.

Table 70. Shared Interrupt Select Register 1 (IRQSS1)

Bit	7	6	5	4	3	2	1	0
Field	Reserved				PCDMA3S	PCDMA2S	Reserved	
Reset	0	0	0	0	0	0	0	0
R/W	R	R	R	R	R/W	R/W	R	R
Address	FCEh							

Bit	Description
[7:4]	Reserved These bits are reserved and must be programmed to 0000.
[3:2] PCDMAxS	PCx/DMAx Selection x indicates the specific Port C bit/DMA channel number (3–2). 0=PCx is used for the interrupt for PCx/DMAx interrupt request. 1=DMAx is used for the interrupt for PCx/DMAx interrupt request.
[1:0]	Reserved These bits are reserved and must be programmed to 00.

9.4.12. Interrupt Control Register

The Interrupt Control (IRQCTL) Register, shown in Table 71, contains the master enable bit for all interrupts.

Table 71. Interrupt Control Register (IRQCTL)

Bit	7	6	5	4	3	2	1	0
Field	IRQE	Reserved						
Reset	0	0	0	0	0	0	0	0
SMR*	0	NC	NC	NC	NC	NC	NC	NC
R/W	R/W	R	R	R	R	R	R	R
Address	FCFh							

Note: *SMR = Effect of Stop-Mode Recovery; NC = No Change.

Bit	Description
[7] IRQE	<p>Interrupt Request Enable</p> <p>This bit is set to 1 by executing an Enable Interrupts (EI) or Interrupt Return (IRET) instruction, or by a direct register write of a 1 to this bit. It is reset to 0 by System Reset, Stop-Mode Recovery, executing a Disable Interrupts (DI) instruction, direct register write of a 0 to this bit, eZ8 CPU acknowledgement of an interrupt request, or by a trap.</p> <p>0: Interrupts are disabled. 1: Interrupts are enabled.</p>
[6:0]	<p>Reserved</p> <p>These bits are reserved and must be programmed to 0000000.</p>

Chapter 10. Timers

The F6482 Series products contain three 16-bit reloadable timers that can be used for timing, event counting, or generation of pulse-width modulated signals. The timers' features include:

- 16-bit reload counter
- One-shot timer
- Programmable prescaler with prescale values ranging from 1 to 128
- PWM output generation
- Capture and compare capability
- Two independent capture/compare channels which reference the common timer
- DMA support
- Event System and external input pin for timer input, clock gating, or capture signal. External input pin signal frequency is limited to a maximum of one-fourth the timer clock frequency
- Timer output to Event System and external pin
- Timer interrupt
- Noise Filter on Timer Input 0 signal
- Operation in any mode with PCLK or WTO; operation in Normal Mode and Halt Mode with SYSCLK, PCLK, or WTO

In addition to the timers described in this chapter, the Baud Rate Generator (BRG) of unused serial port peripherals can also be used to provide basic timing functionality. For more information about using the Baud Rate Generators as additional timers, see the [Electrical Characteristics](#) chapter on page 601, the [Enhanced Serial Peripheral Interface](#) chapter on page 281 and the [I2C Master/Slave Controller](#) chapter on page 306. Furthermore, the RTC Counter Mode can be used to provide basic timing functionality. To learn more regarding the use of RTC Counter Mode, see the [Real-Time Clock](#) chapter on page 210.

10.1. Timer Architecture

Figure 17 shows the architecture of the Timer.

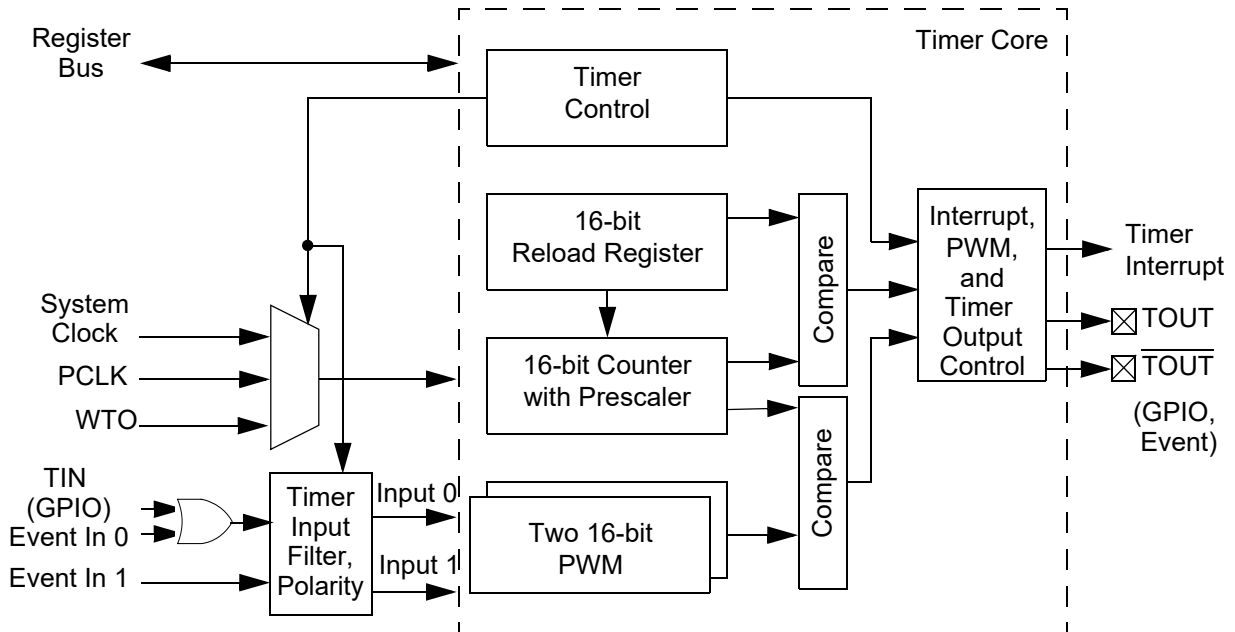

Figure 17. Timer Block Diagram

10.1. Timer Operation

The Timer is a 16-bit up-counter. Minimum time-out delay is set by loading the value 0001h into the Timer Reload High and Low Byte registers and setting the prescale value to 1. Maximum time-out delay is set by loading the value 0000h into the Timer Reload High and Low Byte registers and setting the prescale value to 128. If the Timer reaches FFFFh, the Timer rolls over to 0000h and continues counting.

10.1.1. Timer Clock Source

The timer clock source is selected in TCLKS and can come from either the peripheral clock (PCLK), the Watch-dog Timer Oscillator (WTO), or the System Clock.

For timer operation in Stop Mode, PCLK or the WTO must be selected as the clock source. Either PCLK or the WTO can be selected as source for Active, Halt, and Stop Mode operation. System Clock is only for operation in Active and Halt modes.



Caution: When the timer is operating on PCLK or the WTO, the timer clock is asynchronous to System Clock. To ensure error-free operation, disable the timer before modifying its operation (including changing the timer clock source).

When the Timer uses PCLK or the WTO and the Timer is enabled, any read from TxH or TxL is not recommended, because results can be unpredictable. Disable the Timer first, then read it. If capture, capture/compare, Capture Restart or demodulation mode is selected, any read from TxPWM0H, TxPWM0L, TxPWM1H, TxPWM1L, or TxSTAT must be done after capture interrupt occurs, or results can be unpredictable. INPCAP in the Timer Control 0 Register has the same characteristics as these PWM registers. When the Timer clock selection is System Clock, registers can be written/read at any time.

10.1.2. Low-Power Modes

Timers can operate in both Halt Mode and Stop Mode. This section discusses each of these low-power modes.

10.1.2.1. Operation in Halt Mode

When the eZ8 CPU enters Halt Mode, the Timer will continue to operate if enabled. To minimize current in Halt Mode, the Timer can be disabled by clearing the TEN control bit. The Noise Filter, if enabled, will also continue to operate in Halt Mode and rejects any noise on the Timer Input 0.

10.1.2.2. Operation in Stop Mode

When the eZ8 CPU enters Stop Mode, the Timer continues to operate if enabled and PCLK or the WTO is selected as the timer clock. In Stop Mode, the timer interrupt (if enabled) automatically initiates a Stop-Mode Recovery and generates an interrupt request. In the Reset Status Register, the stop bit is set to 1. Also, timer interrupt request bit in Interrupt Request 0 Register is set. Following completion of the Stop-Mode Recovery, if interrupts are enabled, the CPU responds to the interrupt request by fetching the timer interrupt vector. The Noise Filter, if enabled, will also continue to operate in Stop Mode and rejects any noise on the Timer Input 0.

If System Clock is chosen as the timer clock, the Timer ceases to operate as System Clock is disabled in Stop Mode. In this case the registers are not reset and operation will resume after Stop-Mode Recovery occurs.

10.1.2.3. Power Reduction During Operation

Clearing TEN will inhibit clocking of the Timer. The CPU can still read/write registers when TEN is cleared.

10.1.3. Timer Operating Modes

The Timer can be configured to operate in the following modes, each of which is described in this section where indicated in Table 72.

Table 72. Timer Operating Modes

Mode	Page #
One-Shot Mode	152
Triggered One-Shot Mode	153
Dual Input Triggered One-Shot Mode	155
Continuous Mode	156
Counter Mode	157
PWM Single Output Mode	159
PWM Dual Output Mode	160
Capture Mode	162
Capture Restart Mode	163
Compare Mode	164
Gated Mode	165
Capture/Compare Mode	166
Demodulation Mode	167

10.1.3.1. One-Shot Mode

In One-Shot Mode (TMODE= 0000), the Timer counts timer clocks up to the 16-bit reload value stored in the Timer Reload High and Low Byte registers. Upon reaching the reload value, the Timer generates an interrupt, and the count value in the Timer High and Low Byte registers is reset to 0001h. Then, the Timer is automatically disabled and stops counting.

Additionally, the OUTCTL configuration determines whether the Timer Output changes state for one clock cycle (from Low to High or from High to Low) upon timer reload (OUTCTL=0) or changes state from timer start until timer reload (OUTCTL=1). The Timer Output can be connected to the Event System and, if the Timer Output alternate function is enabled, to the Timer Output pin. If it is appropriate to have the Timer Output make a persistent state change on One-Shot time-out, first configure the TPOL in the Timer Control 1 Register to the start value before beginning One-Shot Mode. Then, after starting the timer, configure TPOL to the opposite bit value.

Observe the following steps to configure a timer for One-Shot Mode and to initiate the count.

1. Write to the Timer Control 1 Register to:

- Disable the timer
 - Configure the timer for One-Shot Mode
 - Set the prescale value
 - If using the Timer Output alternate function or the Event System, set the initial output level (High or Low) and configure the output behavior (OUTCTL)
2. Write to the Timer Control 2 Register to choose the timer clock source.
 3. Write to the Timer Control 0 Register to set the timer interrupt configuration field TICONFIG.
 4. Write to the Timer High and Low Byte registers to set the starting count value.
 5. Write to the Timer Reload High and Low Byte registers to set the reload value.
 6. If required, enable the timer interrupt and set the timer interrupt priority by writing to the relevant interrupt registers.
 7. If using the Timer Output function, configure the associated GPIO port pin for the Timer Output alternate function. If using the Event System, configure it to route the Timer Output to the desired destination.
 8. Write to the Timer Control 1 Register to enable the timer and initiate counting.

In One-Shot Mode, the timer clock always provides the timer input. The timer period is calculated using the following equation:

$$\text{ONE-SHOT Mode Time-Out Period (s)} = \frac{\text{Reload Value} - \text{Start Value} \times \text{Prescale}}{\text{Timer Clock Frequency (Hz)}}$$

10.1.3.2. Triggered One-Shot Mode

In Triggered One-Shot Mode (TMODE=1011), the Timer Input 0 signal triggers counting. Two timer output options and four interrupt options are available. Timer Input 1 can be used in the interrupt control to signal that a trigger event occurred while counting. If a trigger event occurs while counting, INPCAP is set to indicate that the interrupt is due to the trigger event. If a reload occurs, INPCAP is cleared to indicate that the interrupt is not due to a trigger event. The timer operates in the following sequence:

1. The Timer idles until a trigger is received. The Timer trigger, the Input 0 signal, is taken from the GPIO port pin timer input alternate function or from the Event System. If required, enable the Noise Filter and set the Noise Filter control by writing to the relevant bits in the Noise Filter Control Register. The TPOL bit in the Timer Control 1 Register selects whether the triggering occurs on the rising edge or the falling edge of the timer Input 0 signal. Note that when OUTCTL = 1, falling edge triggering is not available, and should therefore not be selected.

2. Following the trigger event, the Timer counts timer clocks up to the 16-bit reload value stored in the Timer Reload High and Low Byte registers.
3. The timer output polarity is selected by TPOL and timer output behavior is selected in OUTCTL to be one of the following:
 - OUTCTL=0: Pulse at reload lasting one timer clock
 - OUTCTL=1: Pulse from start to reload; only TPOL = 0 is allowed.
4. Timer interrupt behavior is selected by TICONFIG to occur upon one of the following:
 - TICONFIG=00: All Reload and Trigger while counting Events
 - TICONFIG=01: Only on timer Input 0 trigger events while counting
 - TICONFIG=10: Only on timer Input 1 trigger events while counting
 - TICONFIG=11: Only on reload events
5. Upon reaching the reload value, the timer resets the count value in the Timer High and Low Byte registers to 0001h. The Timer now idles until the next timer Input 0 trigger event.

In Triggered One-Shot Mode, the timer clock always provides the timer input. The timer period is shown in the following equation:

$$\text{Triggered ONE-SHOT Mode Time-Out Period (s)} = \frac{(\text{Reload Value} - \text{Start Value}) \times \text{Prescale}}{\text{Timer Clock Frequency (Hz)}}$$

Table 73 provides an example initialization sequence for configuring Timer 0 in Triggered One-Shot Mode and initiating operation.

Table 73. Triggered One-Shot Mode Initialization Example

Register	Value	Comment
T0CTL0	E0h	TMODE[3:0]=1011b selects Triggered One-Shot Mode.
T0CTL1	03h	TICONFIG[1:0]=11b enables interrupts on Timer reload only.
T0CTL2	01h	PWMD[2:0]=000b has no effect. INPCAP=0 has no effect. TEN=0 disables the timer. OUTCTL=0b selects a single clock output pulse upon timer reload. TPOL=0 enables triggering on rising edge of Timer Input 0 and sets the Timer Output signal to 0. PRES[2:0]=000b sets prescaler to divide by 1. TCLKS=10b selects PCLK as the Timer clock source.

Table 73. Triggered One-Shot Mode Initialization Example (Continued)

Register	Value	Comment
T0H	00h	Timer starting value=0001h.
T0L	01h	
T0RH	ABh	Timer reload value=ABCDh.
T0RL	CDh	
PAADDR	02h	Selects Port A Alternate Function Register.
PACTL[1:0]	11b	PACTL[0] enables Timer 0 Input Alternate function if also selected by the Alternate Function Set 1 Register. PACTL[1] enables Timer 0 Output Alternate function if also selected by the Alternate Function Set 1 Register.
PAADDR	07h	Selects Port A Alternate Function Set 1 Register.
PACTL[1:0]	00b	PACTL[0] enables Timer 0 Input Alternate function. PACTL[1] enables Timer 0 Output Alternate function.
ESDADDR	10h	Selects the Timer 0 Input 0 Event System Destination.
ESDCTL	00h	Disconnects the Event System Input0 to Timer 0.
IRQ0ENH[5]	0b	Disables the Timer 0 interrupt.
IRQ0ENL[5]	0b	
T0CTL1	83h	TEN=1 enables the timer. All other bits remain in their appropriate settings.

Note: After receiving an input trigger, Timer 0 will:

1. Count ABCDh timer clocks.
2. Upon Timer 0 reload, generate a single clock cycle active High output pulse on the Timer 0 Output.
3. Wait for the next input trigger event.

10.1.3.3. Dual Input Triggered One-Shot Mode

In Dual Input Triggered One-Shot Mode (TMODE=1010), the first to arrive of the timer Input 0 or Input 1 signals triggers counting. In addition, the input that was first to arrive is recorded by the timer for later use in interrupt and output generation. Two timer output options and four interrupt options are available. Previous and current timer input triggers can be used in the interrupt control. If a trigger event occurs while counting, INPCAP is set to indicate that the interrupt is due to the trigger event. If a reload occurs, INPCAP is cleared to indicate that the interrupt is not due to a trigger event. The timer operates in the following sequence:

1. The Timer idles until a trigger is received. Due to the assertion of an input, both inputs must initially be deasserted to receive a new trigger. The Timer trigger, in essence the first to arrive of the timer Input 0 and Input 1 signals, is taken from the GPIO port pin timer input alternate function or from the Event System. If required, enable the Noise Filter and set the Noise Filter control by writing to the relevant bits in the Noise Filter Control Register. The TPOL bit in the Timer Control 1 Register selects whether the

trigger occurs on the rising edge or the falling edge of the timer Input 0 signal. Note that when OUTCTL = 1, falling edge triggering is not available, and should therefore not be selected.

2. Following the trigger event, the Timer counts timer clocks up to the 16-bit reload value stored in the Timer Reload High and Low Byte registers.
3. The timer output polarity is selected by TPOL and timer output behavior is selected in OUTCTL to be one of the following:
 - OUTCTL=0: Pulse at reload lasting one timer clock
 - OUTCTL=1: Pulse from start to reload; only TPOL = 0 is allowed
4. Timer interrupt behavior is selected by TICONFIG to occur upon one of the following:
 - TICONFIG=00: All reload events and all trigger events while counting
 - TICONFIG=01: Only on same input trigger events while counting
 - TICONFIG=10: Only on opposite input trigger events while counting
 - TICONFIG=11: Only on reload events
5. Upon reaching the reload value, the timer resets the count value in the Timer High and Low Byte registers to 0001h. The Timer now idles until the next timer Input 0 or Input 1 trigger event.

In Dual Input Triggered One-Shot Mode, the timer clock always provides the timer input. The timer period is shown in the following equation:

$$\text{Triggered ONE-SHOT Mode Time-Out Period (s)} = \frac{(\text{Reload Value} - \text{Start Value}) \times \text{Prescale}}{\text{Timer Clock Frequency (Hz)}}$$

10.1.3.4. Continuous Mode

In Continuous Mode (TMODE=0001), the timer counts timer clocks up to the 16-bit reload value stored in the Timer Reload High and Low Byte registers. Upon reaching the reload value, the timer generates an interrupt, the count value in the Timer High and Low Byte registers is reset to 0001h and counting resumes. Also, the Timer Output changes state (from Low to High or High to Low) on timer reload. The Timer Output can be connected to the Event System and, if the Timer Output alternate function is enabled, to the Timer Output pin.

Observe the following steps to configure a timer for Continuous Mode and initiate the count:

1. Write to the Timer Control 1 Register to:
 - Disable the timer

- Configure the timer for Continuous Mode
 - Set the prescale value
 - If using the Timer Output Alternate Function or the Event System, set the initial output level (High or Low)
2. Write to the Timer Control 2 Register to choose the timer clock source.
 3. Write to the Timer Control 0 Register to set the timer interrupt-configuration field TICONFIG.
 4. Write to the Timer High and Low Byte registers to set the starting count value (usually 0001h). This value only affects the first pass in Continuous Mode. After the first timer reload in Continuous Mode, counting always begins at the reset value of 0001h.
 5. Write to the Timer Reload High and Low Byte registers to set the reload value.
 6. If appropriate, enable the timer interrupt and set the timer interrupt priority by writing to the relevant interrupt registers.
 7. If using the Timer Output function, configure the associated GPIO port pin for the Timer Output alternate function. If using the Event System, configure it to route the Timer Output to the desired destination.
 8. Write to the Timer Control 1 Register to enable the timer and initiate counting.

In Continuous Mode, the timer clock always provides the timer input. The timer period is calculated using the following equation:

$$\text{CONTINUOUS Mode Time-Out Period (s)} = \frac{\text{Reload Value} \times \text{Prescale}}{\text{Timer Clock Frequency (Hz)}}$$

If an initial starting value other than 0001h is loaded into the Timer High and Low Byte registers, the One-Shot Mode equation must be used to determine the first time-out period.

10.1.3.5. Counter Mode

In Counter Mode (TMODE=0010), the timer counts timer Input 0 signal transitions. The timer Input 0 signal is taken from the GPIO Port pin Timer Input alternate function or from the Event System Input 0. The TPOL bit in the Timer Control 1 Register selects whether the count occurs on the rising edge or the falling edge of the Timer Input 0 signal. In Counter Mode, the prescaler is disabled.



Caution: The input frequency of the Timer Input signal must not exceed one-fourth the timer clock frequency.

Upon reaching the reload value stored in the Timer Reload High and Low Byte registers, the timer generates an interrupt, the count value in the Timer High and Low Byte registers is reset to 0001h and counting resumes. Also, the Timer Output pin changes state (from Low to High or High to Low) at timer reload. The Timer Output can be connected to the Event System and, if the Timer Output alternate function is enabled, to the Timer Output pin.

Observe the following steps to configure a timer for Counter Mode and initiate the count:

1. Write to the Timer Control 1 Register to:
 - Disable the timer.
 - Configure the timer for Counter Mode.
 - Select either the rising edge or falling edge of the Timer Input 0 signal for the count. This also sets the initial logic level (High or Low) for the Timer Output Alternate Function. However, the Timer Output function is not required to be enabled.
2. Write to the Timer Control 2 Register to choose the timer clock source.
3. Write to the Timer Control 0 Register to set the timer interrupt configuration field TICONFIG.
4. Write to the Timer High and Low Byte registers to set the starting count value. This value only affects the first pass in Counter Mode. After the first timer reload in Counter Mode, counting always begins at the reset value of 0001h. Generally, in Counter Mode the Timer High and Low Byte registers should be written with the value 0001h.
5. Write to the Timer Reload High and Low Byte registers to set the reload value.
6. If required, enable the timer interrupt and set the timer interrupt priority by writing to the relevant interrupt registers.
7. If required, enable the Noise Filter and set the Noise Filter control by writing to the relevant bits in the Noise Filter Control Register.
8. Configure the associated GPIO port pin for the Timer Input alternate function or configure the desired Event System Timer Input 0.
9. When using the Timer Output, configure the associated GPIO port pin for the Timer Output alternate function or configure the Event System to route the Timer Output to the desired destination.
10. Write to the Timer Control 1 Register to enable the timer.

In Counter Mode, the number of Timer Input 0 transitions since the timer start is calculated using the following equation:

$$\text{COUNTER Mode Timer Input Transitions} = \text{Current Count Value} - \text{Start Value}$$

10.1.3.6. PWM Single Output Mode

In PWM Single Output Mode (TMODE=0011), the timer outputs a Pulse Width Modulator output signal through a GPIO Port pin and/or to the Event System. The Timer counts timer clocks up to the 16-bit reload value. The timer first counts up to the 16-bit PWM match value stored in the Timer PWM0 High and Low Byte registers. When the timer count value matches the PWM value, the Timer Output toggles. The timer continues counting until it reaches the reload value stored in the Timer Reload High and Low Byte registers. Upon reaching the reload value, the timer generates an interrupt, the count value in the Timer High and Low Byte registers is reset to 0001h and counting resumes.

If the TPOL bit in the Timer Control 1 Register is set to 1, the Timer Output signal begins as High (1) and then transitions to Low (0) when the timer value matches the PWM value. The Timer Output signal returns to High (1) after the timer reaches the reload value and is reset to 0001h.

If the TPOL bit in the Timer Control 1 Register is set to 0, the Timer Output signal begins as Low (0) and then transitions to High (1) when the timer value matches the PWM value. The Timer Output signal returns to Low (0) after the timer reaches the reload value and is reset to 0001h.

Observe the following steps to configure a timer for PWM Single Output Mode and initiate PWM operation:

1. Write to the Timer Control 1 Register to:
 - Disable the timer
 - Configure the timer for PWM Mode
 - Set the prescale value
 - Set the initial logic level (High or Low) and PWM High/Low transition for the Timer Output Alternate Function
2. Write to the Timer Control 2 Register to choose the timer clock source.
3. Write to the Timer Control 0 Register to set the timer interrupt configuration field TICONFIG.
4. Write to the Timer High and Low Byte registers to set the starting count value (typically 0001h). This value only affects the first pass in PWM Mode. After the first timer reset in PWM Mode, counting always begins at the reset value of 0001h.
5. Write to the Timer PWM0 High and Low Byte registers to set the PWM value.
6. Write to the Timer Reload High and Low Byte registers to set the reload value (PWM period). The reload value must be greater than the PWM value.
7. If appropriate, enable the timer interrupt and set the timer interrupt priority by writing to the relevant interrupt registers.

8. Configure the associated GPIO port pin for the Timer Output alternate function and/or the Event System to route the Timer Output to the desired destination.
9. Write to the Timer Control 1 Register to enable the timer and initiate counting.

The PWM period is calculated using the following equation:

$$\text{PWM Period (s)} = \frac{\text{Reload Value} \times \text{Prescale}}{\text{Timer Clock Frequency (Hz)}}$$

If an initial starting value other than 0001h is loaded into the Timer High and Low Byte registers, the One-Shot Mode equation must be used to determine the first PWM time-out period.

If TPOL is set to 0, the ratio of the PWM output High time to the total period is calculated using the following equation:

$$\text{PWM Output High Time Ratio (\%)} = \frac{\text{Reload Value} - \text{PWM Value}}{\text{Reload Value}} \times 100$$

If TPOL is set to 1, the ratio of the PWM output High time to the total period is calculated using the following equation:

$$\text{PWM Output High Time Ratio (\%)} = \frac{\text{PWM Value}}{\text{Reload Value}} \times 100$$

10.1.3.7. PWM Dual Output Mode

In PWM Dual Output Mode (TMODE=1000), the timer outputs a Pulse Width Modulator output signal and also its complement through two GPIO Port pins and/or to the Event System. The timer first counts up to 16-bit PWM match value stored in the Timer PWM0 High and Low Byte registers. When the timer count value matches the PWM value, the Timer Outputs (TOUT and $\overline{\text{TOUT}}$) toggle. The timer continues counting until it reaches the reload value stored in the Timer Reload High and Low Byte registers. Upon reaching the reload value, the timer generates an interrupt, the count value in the Timer High and Low Byte registers is reset to 0001h and TOUT and $\overline{\text{TOUT}}$ toggles again and counting resumes.

If the TPOL bit in the Timer Control 1 Register is set to 1, the Timer Output signal begins as High (1) and then transitions to Low (0) when the timer value matches the PWM value. The Timer Output signal returns to High (1) after the timer reaches the reload value and is reset to 0001h.

If the TPOL bit in the Timer Control 1 Register is set to 0, the Timer Output signal begins as Low (0) and then transitions to High (1) when the timer value matches the PWM value. The Timer Output signal returns to Low (0) after the timer reaches the reload value and is reset to 0001h.

The timer also generates a second PWM output signal, Timer Output Complement (TO $\bar{U}T$). TO $\bar{U}T$ is the complement of the Timer Output PWM signal (TO U T). A programmable deadband delay can be configured to set a time delay (0 to 128 timer clock cycles) when one PWM output transitions from High to Low and the other PWM output transitions from a Low to High. This configuration ensures a time gap between the removal of one PWM output and the assertion of its complement.

Observe the following steps to configure a timer for PWM Dual Output Mode and initiate the PWM operation:

1. Write to the Timer Control 1 Register to:
 - Disable the timer
 - Configure the timer for PWM Dual Output Mode. Setting the mode also involves writing to TMODE[3] bit in the TxCTL0 Register
 - Set the prescale value
 - Set the initial logic level (High or Low) and PWM High/Low transition for the Timer Output Alternate Function
2. Write to the Timer High and Low Byte registers to set the starting count value (typically 0001h). This value only affects the first pass in PWM Mode. After the first timer reset in PWM Mode, counting always begins at the reset value of 0001h.
3. Write to the Timer PWM0 High and Low Byte registers to set the PWM value.
4. Write to the Timer Control 0 Register:
 - To set the PWM deadband delay value
 - To choose the timer clock source
5. Write to the Timer Control 0 Register to set the timer interrupt configuration field TICONFIG.
6. Write to the Timer Reload High and Low Byte registers to set the reload value (PWM period). The reload value must be greater than the PWM value.
7. If appropriate, enable the timer interrupt and set the timer interrupt priority by writing to the relevant interrupt registers.
8. Configure the associated GPIO port pin for the Timer Output and Timer Output Complement alternate functions and/or the Event System to route the Timer Output to the desired destination.
9. Write to the Timer Control 1 Register to enable the timer and initiate counting.

The PWM period is calculated using the following equation:

$$\text{PWM Period (s)} = \frac{\text{Reload Value} \times \text{Prescale}}{\text{Timer Clock Frequency (Hz)}}$$

If an initial starting value other than 0001h is loaded into the Timer High and Low Byte registers, the One-Shot Mode equation must be used to determine the first PWM time-out period.

If TPOL is set to 0, the ratio of the PWM output High time to the total period is calculated using the following equation:

$$\text{PWM Output High Time Ratio (\%)} = \frac{\text{Reload Value} - \text{PWM Value}}{\text{Reload Value}} \times 100$$

If TPOL is set to 1, the ratio of the PWM output High time to the total period is calculated using the following equation:

$$\text{PWM Output High Time Ratio (\%)} = \frac{\text{PWM Value}}{\text{Reload Value}} \times 100$$

10.1.3.8. Capture Mode

In Capture Mode (TMODE=0100), the current timer count value is recorded when the appropriate external Timer Input 0 transition occurs. The Capture count value is written to the Timer PWM0 High and Low Byte registers. The Timer counts timer clocks up to the 16-bit reload value. The TPOL bit in the Timer Control 1 Register determines if the Capture occurs on a rising edge or a falling edge of the Timer Input 0 signal. When the Capture event occurs, an interrupt is generated and the timer continues counting. The INPCAP bit in Timer Control 0 Register is set to indicate the timer interrupt is due to an input capture event.

The timer continues counting up to the 16-bit reload value stored in the Timer Reload High and Low Byte registers. Upon reaching the reload value, the timer generates an interrupt and continues counting. The INPCAP bit in Timer Control 0 Register is cleared to indicate the timer interrupt is not due to an input capture event.

Observe the following steps to configure a timer for Capture Mode and initiate the count:

1. Write to the Timer Control 1 Register to:
 - Disable the timer
 - Configure the timer for Capture Mode
 - Set the prescale value
 - Set the Capture edge (rising or falling) for the Timer Input 0
2. Write to the Timer Control 2 Register to choose the timer clock source.
3. Write to the Timer Control 0 Register to set the timer interrupt configuration field TICONFIG.
4. Write to the Timer High and Low Byte registers to set the starting count value (typically 0001h).

5. Write to the Timer Reload High and Low Byte registers to set the reload value.
6. Clear the Timer PWM High and Low Byte registers to 0000h. This allows user software to determine if interrupts were generated by either a capture event or a reload. If the PWM0 High and Low Byte registers still contain 0000h after the interrupt, then the interrupt was generated by a Reload.
7. If required, enable the timer interrupt and set the timer interrupt priority by writing to the relevant interrupt registers. By default, the timer interrupt will be generated for both input capture and reload events. If required, configure the timer interrupt to be generated only at the input capture event or the reload event by setting TICONFIG field of the Timer Control 0 Register.
8. Configure the associated GPIO port pin for the Timer Input alternate function or configure the desired Event System Timer Input 0.
9. Write to the Timer Control 1 Register to enable the timer and initiate counting.

In Capture Mode, the elapsed time from timer start to Capture event can be calculated using the following equation:

$$\text{Capture Elapsed Time (s)} = \frac{(\text{Capture Value} - \text{Start Value}) \times \text{Prescale}}{\text{Timer Clock Frequency (Hz)}}$$

10.1.3.9. Capture Restart Mode

In Capture Restart Mode (TMODE=1001), the current timer count value is recorded when the appropriate external Timer Input 0 transition occurs. The Capture count value is written to the Timer PWM0 High and Low Byte registers. The Timer counts timer clocks up to the 16-bit reload value. The TPOL bit in the Timer Control 1 Register determines if the Capture occurs on a rising edge or a falling edge of the Timer Input 0 signal. When the Capture event occurs, an interrupt is generated and the count value in the Timer High and Low Byte registers is reset to 0001h and counting resumes. The INPCAP bit in Timer Control 0 Register is set to indicate the timer interrupt is due to an input capture event.

If no Capture event occurs, the timer counts up to the 16-bit Compare value stored in the Timer Reload High and Low Byte registers. Upon reaching the reload value, the timer generates an interrupt, the count value in the Timer High and Low Byte registers is reset to 0001h and counting resumes. The INPCAP bit in Timer Control 0 Register is cleared to indicate the timer interrupt is not due to an input capture event.

Observe the following steps to configure a timer for Capture Restart Mode and initiate the count:

1. Write to the Timer Control 1 Register to:
 - Disable the timer
 - Configure the timer for Capture Restart Mode. Setting the mode also involves writing to TMODE[3] bit in the TxCTL0 Register

- Set the prescale value
 - Set the Capture edge (rising or falling) for the Timer Input 0
2. Write to the Timer Control 2 Register to choose the timer clock source.
 3. Write to the Timer Control 0 Register to set the timer interrupt configuration field TICONFIG.
 4. Write to the Timer High and Low Byte registers to set the starting count value (typically 0001h).
 5. Write to the Timer Reload High and Low Byte registers to set the reload value.
 6. Clear the Timer PWM High and Low Byte registers to 0000h. This allows user software to determine if interrupts are generated by either a Capture Event or a Reload. If the PWM0 High and Low Byte registers still contain 0000h after the interrupt, then the interrupt is generated by a Reload.
 7. If required, enable the timer interrupt and set the timer interrupt priority by writing to the relevant interrupt registers. By default, the timer interrupt will be generated for both input capture and reload events. If required, configure the timer interrupt to be generated only at the Input Capture event or the reload event by setting TICONFIG field of the Timer Control 0 Register.
 8. Configure the associated GPIO port pin for the Timer Input alternate function or configure the desired Event System Timer Input 0.
 9. Write to the Timer Control 1 Register to enable the timer and initiate counting.

In Capture Mode, the elapsed time from Timer start to Capture event can be calculated using the following equation:

$$\text{Capture Elapsed Time (s)} = \frac{(\text{Capture Value} - \text{Start Value}) \times \text{Prescale}}{\text{Timer Clock Frequency (Hz)}}$$

10.1.3.10. Compare Mode

In Compare Mode (TMODE=0101), the timer counts timer clocks up to the 16-bit maximum Compare value stored in the Timer Reload High and Low Byte registers. Upon reaching the Compare value, the timer generates an interrupt and counting continues (the timer value is not reset to 0001h). Also, the Timer Output changes state (from Low to High or from High to Low) on Compare. The Timer Output can be connected to the Event System and, if the Timer Output alternate function is enabled, to the Timer Output pin.

If the Timer reaches FFFFh, the timer rolls over to 0000h and continues counting.

Observe the following steps to configure a timer for Compare Mode and initiate the count:

1. Write to the Timer Control 1 Register to:
 - Disable the timer

- Configure the timer for Compare Mode
 - Set the prescale value
 - Set the initial logic level (High or Low) for the Timer Output, if required
2. Write to the Timer Control 2 Register to choose the timer clock source.
 3. Write to the Timer Control 0 Register to set the timer interrupt configuration field, TICONFIG.
 4. Write to the Timer High and Low Byte registers to set the starting count value.
 5. Write to the Timer Reload High and Low Byte registers to set the Compare value.
 6. If appropriate, enable the timer interrupt and set the timer interrupt priority by writing to the relevant interrupt registers.
 7. If using the Timer Output function, configure the associated GPIO port pin for the Timer Output alternate function. If using the Event System, configure it to route the Timer Output to the desired destination.
 8. Write to the Timer Control 1 Register to enable the timer and initiate counting.

In Compare Mode, the timer clock always provides the timer input. The Compare time is calculated using the following equation:

$$\text{COMPARE Mode Time (s)} = \frac{(\text{Compare Value} - \text{Start Value}) \times \text{Prescale}}{\text{Timer Clock Frequency (Hz)}}$$

10.1.3.11. Gated Mode

In Gated Mode (TMODE=0110), the timer counts only when the Timer Input 0 signal is in its active state (asserted) as determined by the TPOL bit in the Timer Control 1 Register. When the Timer Input 0 signal is asserted, counting begins. A Timer Interrupt is generated when the Timer Input 0 signal is deasserted or a timer reload occurs. The INPCAP bit in Timer Control 0 Register is set to indicate the timer interrupt is due to the Timer Input signal.

The timer counts up to the 16-bit reload value stored in the Timer Reload High and Low Byte registers using the timer clock. When reaching the reload value, the timer generates an interrupt, the count value in the Timer High and Low Byte registers is reset to 0001h and counting resumes (assuming the Timer Input 0 signal is still asserted). Also, the Timer Output changes state (from Low to High or from High to Low) at timer reset. The Timer Output can be connected to the Event System and, if the Timer Output alternate function is enabled, to the Timer Output pin.

Observe the following steps to configure a timer for Gated Mode and initiate the count:

1. Write to the Timer Control 1 Register to:

- Disable the timer
 - Configure the timer for Gated Mode
 - Set the prescale value
2. Write to the Timer Control 2 Register to choose the timer clock source.
 3. Write to the Timer Control 0 Register to set the timer interrupt configuration field TICONFIG.
 4. Write to the Timer High and Low Byte registers to set the starting count value. This value only affects the first pass in Gated Mode. After the first timer reset in Gated Mode, counting always begins at the reset value of 0001h.
 5. Write to the Timer Reload High and Low Byte registers to set the reload value.
 6. If required, enable the timer interrupt and set the timer interrupt priority by writing to the relevant interrupt registers. By default, the timer interrupt will be generated for both input deassertion and reload events. If required, configure the timer interrupt to be generated only at the Input Deassertion event or the Reload event by setting TICONFIG field of the Timer Control 0 Register.
 7. Configure either the associated GPIO port pin for the Timer Input alternate function or the Event System Timer Input 0.
 8. Write to the Timer Control 1 Register to enable the timer.
 9. Assert the Timer Input 0 signal to initiate the counting.

10.1.3.12. Capture/Compare Mode

In Capture/Compare Mode (TMODE=0111), the timer begins counting on the first external Timer Input 0 transition. The appropriate transition (rising edge or falling edge) is set by the TPOL bit in the Timer Control 1 Register. The Timer counts timer clocks up to the 16-bit reload value.

Every subsequent appropriate transition (after the first) of the Timer Input 0 signal captures the current count value. The Capture value is written to the Timer PWM0 High and Low Byte registers. When the Capture event occurs, an interrupt is generated, the count value in the Timer High and Low Byte registers is reset to 0001h and counting resumes. The INPCAP bit in Timer Control 0 Register is set to indicate the timer interrupt is due to an input capture event.

If no Capture event occurs, the timer counts up to the 16-bit Compare value stored in the Timer Reload High and Low Byte registers. Upon reaching the Compare value, the timer generates an interrupt, the count value in the Timer High and Low Byte registers is reset to 0001h and counting resumes. The INPCAP bit in Timer Control 0 Register is cleared to indicate the timer interrupt is not due to an input capture event.

Observe the following steps to configure a timer for Capture/Compare Mode and initiate the count:

1. Write to the Timer Control 1 Register to:
 - Disable the timer
 - Configure the timer for Capture/Compare Mode
 - Set the prescale value
 - Set the Capture edge (rising or falling) for the Timer Input 0
2. Write to the Timer High and Low Byte registers to set the starting count value (typically 0001h).
3. Write to the Timer Control 2 Register to choose the timer clock source.
4. Write to the Timer Control 0 Register to set the timer interrupt configuration field TICONFIG.
5. Write to the Timer Reload High and Low Byte registers to set the Compare value.
6. If required, enable the timer interrupt and set the timer-interrupt priority by writing to the relevant interrupt registers. By default, the timer interrupt will be generated for both input capture and reload events. If required, configure the timer interrupt to be generated only at the input Capture event or the Reload event by setting TICONFIG field of the Timer Control 0 Register.
7. Configure the associated GPIO port pin for the Timer Input alternate function or configure the desired Event System Timer Input 0.
8. Write to the Timer Control 1 Register to enable the timer.
9. Counting begins on the first transition of the Timer Input 0 signal. No interrupt is generated by this first edge.

In Capture/Compare Mode, the elapsed time from timer start to Capture event is calculated using the following equation:

$$\text{apture Elapsed Time (s)} = \frac{(\text{Capture Value} - \text{Start Value}) \times \text{Prescale}}{\text{Timer Clock Frequency (Hz)}}$$

10.1.3.13. Demodulation Mode

In Demodulation Mode (TMODE=1100), the timer begins counting on the first external Timer Input 0 transition. The appropriate transition (rising edge or falling edge or both) is set by the TPOL bit in the Timer Control 1 Register and TPOLHI bit in the Timer Control 2 Register. The Timer counts timer clocks up to the 16-bit reload value.

Every subsequent appropriate transition (after the first) of the Timer Input 0 signal captures the current count value. The Capture value is written to the Timer PWM0 High and

Low Byte registers for rising input edges of the Timer Input 0 signal. For falling edges the capture count value is written to the Timer PWM1 High and Low Byte registers. The TPOL bit in the Timer Control 1 Register determines if the Capture occurs on a rising edge or a falling edge of the Timer Input 0 signal. If the TPOLHI bit in the Timer Control 2 Register is set, a Capture is executed on both the rising and falling edges of the input signal.

Whenever the Capture event occurs, an interrupt is generated and the timer continues counting. The corresponding event flag bit in the Timer Status Register, PWMxEF, is set to indicate that the timer interrupt is due to an input Capture event.

The timer counts up to the 16-bit Compare value stored in the Timer Reload High and Low Byte registers. Upon reaching the reload value, the timer generates an interrupt, the count value in the Timer High and Low Byte registers is reset to 0001h, and counting resumes. The RTOEF event flag bit in the Timer Status Register is set to indicate that the timer interrupt is due to a Reload event. Software can use this bit to determine if a Reload occurred prior to a Capture.

Observe the following steps to configure a timer for Demodulation Mode and initiate the count:

1. Write to the Timer Control 1 Register to:
 - Disable the timer.
 - Configure the timer for Demodulation Mode. Setting the mode also involves writing to the TMODEHI bit in the TxCTL0 Register.
 - Set the prescale value.
 - Set the TPOL bit to set the Capture edge (rising or falling) for the Timer Input 0. This setting applies only if the TPOLHI bit in the TxCTL2 Register is not set.
2. Write to the Timer Control 2 Register to:
 - Choose the timer clock source.
 - Set the TPOLHI bit if the Capture is required on both edges of the input signal.
3. Write to the Timer Control 0 Register to set the timer interrupt configuration field TICONFIG.
4. Write to the Timer High and Low Byte registers to set the starting count value (typically 0001h).
5. Write to the Timer Reload High and Low Byte registers to set the reload value.
6. Clear the Timer TxPWM0 and TxPWM1 High and Low Byte registers to 0000h.
7. If required, enable the Noise Filter and set the Noise Filter control by writing to the relevant bits in the Noise Filter Control Register.

8. If required, enable the timer interrupt and set the timer interrupt priority by writing to the relevant interrupt registers. By default, the timer interrupt will be generated for both input capture and reload events. If required, configure the timer interrupt to be generated only at the input Capture event or the Reload event by setting TICONFIG field of the Timer Control 0 Register.
9. Configure the associated GPIO Port pin for the Timer Input alternate function or configure the desired Event System Timer Input 0.
10. Write to the Timer Control 1 Register to enable the timer. Counting will start on the occurrence of the first external input transition.

In Demodulation Mode, the elapsed time from timer start to Capture event can be calculated using the following equation:

$$\text{Capture Elapsed Time (s)} = \frac{(\text{Capture Value} - \text{Start Value}) \times \text{Prescale}}{\text{Timer Clock Frequency (Hz)}}$$

Table 74 provides an example initialization sequence for configuring Timer 0 in Demodulation Mode and initiating operation.

Table 74. Demodulation Mode Initialization Example

Register	Value	Comment
T0CTL0	C0h	TMODE[3:0]=1100b selects Demodulation Mode.
T0CTL1	04h	TICONFIG[1:0]=10b enables interrupt only on Capture events.
T0CTL2	11h	PWMD[2:0]=000b has no effect. INPCAP=0 has no effect. TEN=0 disables the timer. PRES[2:0]=000b sets prescaler to divide by 1. TPOLHI,TPOL=10b enables trigger and Capture on both rising and falling edges of Timer Input. TCLKS=10b enables PCLK as timer clock source
T0H	00h	Timer starting value=0001h.
T0L	01h	
T0RH	ABh	Timer reload value=ABCDh
T0RL	CDh	

Notes After receiving the input trigger (rising or falling edge), Timer 0 will:

1. Start counting on the timer clock.
2. Upon receiving a Timer 0 Input 0 rising edge, save the Capture value in the T0PWM0 registers, generate an interrupt, and continue to count.
3. Upon receiving a Timer 0 Input 0 falling edge, save the Capture value in the T0PWM1 registers, generate an interrupt, and continue to count.
4. After the timer count to ABCD clocks, set the reload event flag and reset the Timer count to the start value.

Table 74. Demodulation Mode Initialization Example (Continued)

Register	Value	Comment
T0PWM0H	00h	Initial PWM0 value=0000h
T0PWM0L	00h	
T0PWM1H	00h	Initial PWM1 value=0000h
T0PWM1L	00h	
T0NFC	70h	NFCTL=0111b enables 8-bit up/down Noise Filter counting
PAADDR	02h	Selects Port A Alternate Function control register.
PACTL[1:0]	11b	PACTL[0] enables Timer 0 Input alternate function. PACTL[1] enables Timer 0 Output alternate function.
PAADDR	07h	Selects Port A Alternate Function Set 1 Register.
PACTL[1:0]	00b	PACTL[0] enables Timer 0 Input Alternate function. PACTL[1] enables Timer 0 Output Alternate function.
ESDADDR	10h	Selects the Timer 0 Input 0 Event System Destination
ESDCTL	00h	Disconnects the Event System Input 0 to Timer 0.
IRQ0ENH[5]	0b	Disables the Timer 0 interrupt.
IRQ0ENL[5]	0b	
T0CTL1	84h	TEN=1 enables the timer. All other bits remain in their appropriate settings.

Notes After receiving the input trigger (rising or falling edge), Timer 0 will:

1. Start counting on the timer clock.
2. Upon receiving a Timer 0 Input 0 rising edge, save the Capture value in the T0PWM0 registers, generate an interrupt, and continue to count.
3. Upon receiving a Timer 0 Input 0 falling edge, save the Capture value in the T0PWM1 registers, generate an interrupt, and continue to count.
4. After the timer count to ABCD clocks, set the reload event flag and reset the Timer count to the start value.

10.1.4. Reading the Timer Count Values

The current count value in the timers can be read while counting (enabled). This capability has no effect on timer operation. When the timer is enabled and the Timer High Byte Register is read, the contents of the Timer Low Byte Register are placed in a holding register. A subsequent read from the Timer Low Byte Register returns the value in the holding register. This operation allows accurate reads of the full 16-bit timer count value while enabled. When the timers are not enabled, a read from the Timer Low Byte Register returns the actual value in the counter.

10.1.5. Timer Interrupts and DMA

The Timer can generate an interrupt request upon reload and capture. In addition, certain input triggering events can generate an interrupt, as described in the [Triggered One-Shot Mode](#) section on page 153 and the [Dual Input Triggered One-Shot Mode](#) section on

page 155. Use TICONFIG to select whether interrupts are generated due to reload, capture or input triggering events. An interrupt request that is pending when the Timer is disabled is not automatically cleared.

DMA request behavior is a function of mode. For all modes except those pertaining to capture and demodulate, DMA request is asserted whenever an interrupt request is asserted. Each Timer DMA request results in a single-byte DMA transfer. This provides a mechanism for DMA transfers to be triggered by the Timer. DMA request is cleared when the DMA services the request or whenever the counter is disabled. Zilog does not recommend DMA for One-Shot Mode, because upon a channel interrupt, the channel is disabled, thereby clearing its DMA request.

For capture modes (TMODE=0100, 0111, 1100) and demodulate mode (TMODE=1100), DMA request is asserted whenever an interrupt is asserted due to capture. Reload interrupts do not cause DMA request to be asserted. DMA request is cleared whenever the Timer PWM0 or PWM1 Low Byte Register is read by the DMA or software or whenever the counter is disabled. For capture modes, the DMA is typically configured to have fixed-word address control for the DMA source address and the source address is configured to be the Timer PWM0 High Byte Register address.

10.1.6. Timer Output Signal Operation

The Timer Outputs, TOUT and $\overline{\text{TOUT}}$, are available as GPIO Port pin alternate functions and a sources to the Event System. $\overline{\text{TOUT}}$ is the complement of TOUT in all timer modes with the special case of DUAL PWM Mode in which the complementary behavior includes deadband insertion. Generally, the Timer Outputs are toggled every time the counter is reloaded. For One-Shot, Triggered One-Shot, and Dual Input Triggered One-Shot modes, the timer output waveforms are controlled by OUTCTL. Output connectivity to Event System destinations is controlled by the Event System registers. GPIO connectivity is controlled by the GPIO alternate function registers.

10.1.7. Timer Input Path and Noise Filter

The timer input path develops two timer inputs from three input signals as followings:

Input 0 is an OR function of a GPIO alternate function (TIN) and Event System Timer Input 0. The result is optionally polarity-adjusted and filtered.

Input 1 is Event System Timer Input 1. A noise filter from another timer can be assigned to this input.

A noise filter circuit is included which filters noise on the Timer Input 0 signal before it reaches the Timer.

The noise filter features the following elements:

- Synchronizes the input signal to the timer clock.

- The Noise Filter Control (NFCTL) input selects whether the Noise Filter is bypassed (NFCTL=0000) and the width of the up/down saturating counter digital filter. The available widths range from 2 bits to 11 bits.
- The digital filter output has hysteresis such that the data output does not change until the saturated value is reached.
- Provides an active-Low *Saturated State* output, FiltSatB, which is used as an indication of the presence of noise.
- Available for operation in Stop Mode.

10.1.7.1. Architecture

Figure 18 shows how the Input Path and Noise Filter are integrated with the Timer.

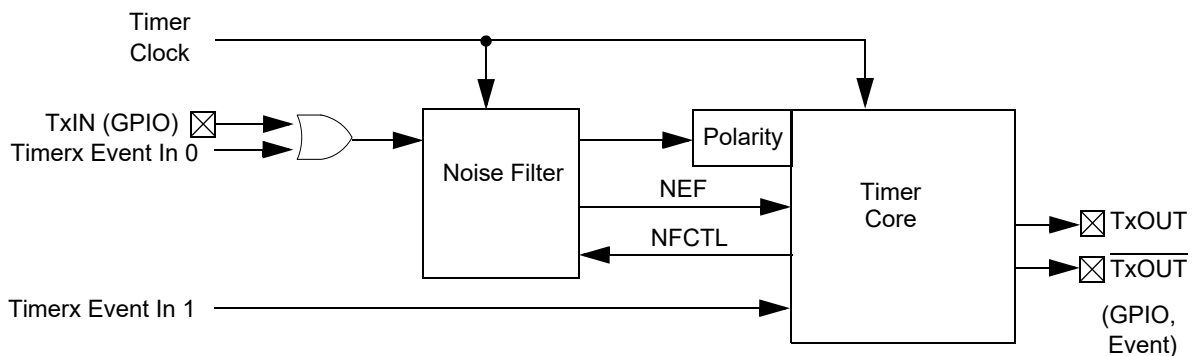

Figure 18. Input Path and Noise Filter System Block Diagram

10.1.7.2. Operation

Three signals are input to the timer: A GPIO alternate function (TIN), Event System Timer Input 0, and Event System Timer Input 1. The GPIO alternate function (TIN) and Event System Timer Input 0 are logically ORed; typically, only one of these is configured to be active at a given time. Any inactive input is held at logic 0.

The ORed signal is operated on by the Noise Filter and polarity adjustment (TPOL) to form the first timer input, Input 0. The Noise Filter is clocked by timer clock and can be used to filter noisy signals or to establish a minimum signal duration. The Event System Timer Input 1 is the second timer input, Input 1.

The OR function at Input 0 allows for special functionality when using one of the capture modes, (TMODE=0100, 0111, 1100). For example, the delay between pulses on two different inputs can be captured.

Timer(x) Input 1 can also be filtered if the Timer(x-1) Noise Filter is assigned to it by setting NFCON for Timer(x-1). As such, Timer(x-1) Input 0 bypasses the Timer(x-1) Noise Filter, the Timer(x-1) Noise Filter is reassigned to Timer(x) Input 1 and uses the Timer(x) timer clock. When reassigning the Timer 2 Noise Filter, it is connected to Timer 0 Input 1.

Figure 19 shows an configuration example with the Timer0 Noise Filter reassigned to Timer1 (NFCON=1 in the T0NFC Register).

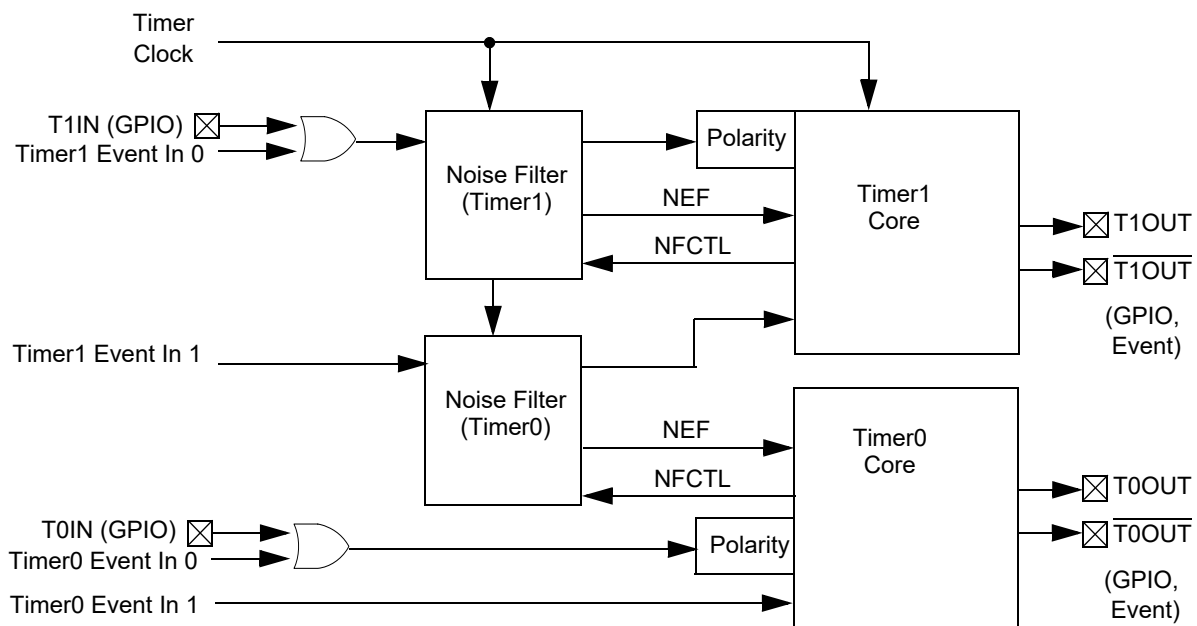

Figure 19. Example with the Timer0 Noise Filter Reassigned to Timer1

Figure 20 shows the operation of the Noise Filter with and without noise. The Noise Filter in this example is a 2-bit up/down counter which saturates at 00 and 11. A 2-bit counter is described for convenience; the operation of wider counters is similar. The output of the filter switches from 1 to 0 when the counter counts down from 01 to 00 and switches from 0 to 1 when the counter counts up from 10 to 11. The Noise Filter delays the receive data by three timer clock cycles.

The NEF output signal is checked when the filtered TxIN input signal is sampled. The Timer samples the filtered TxIN input near the center of the bit time. The NEF signal must be sampled at the same time to detect whether there is noise near the center of the bit time. The presence of noise (NEF=1 at the center of the bit time) does not mean that the sampled data is incorrect; rather, it is intended to be an indicator of the level of noise in the network.

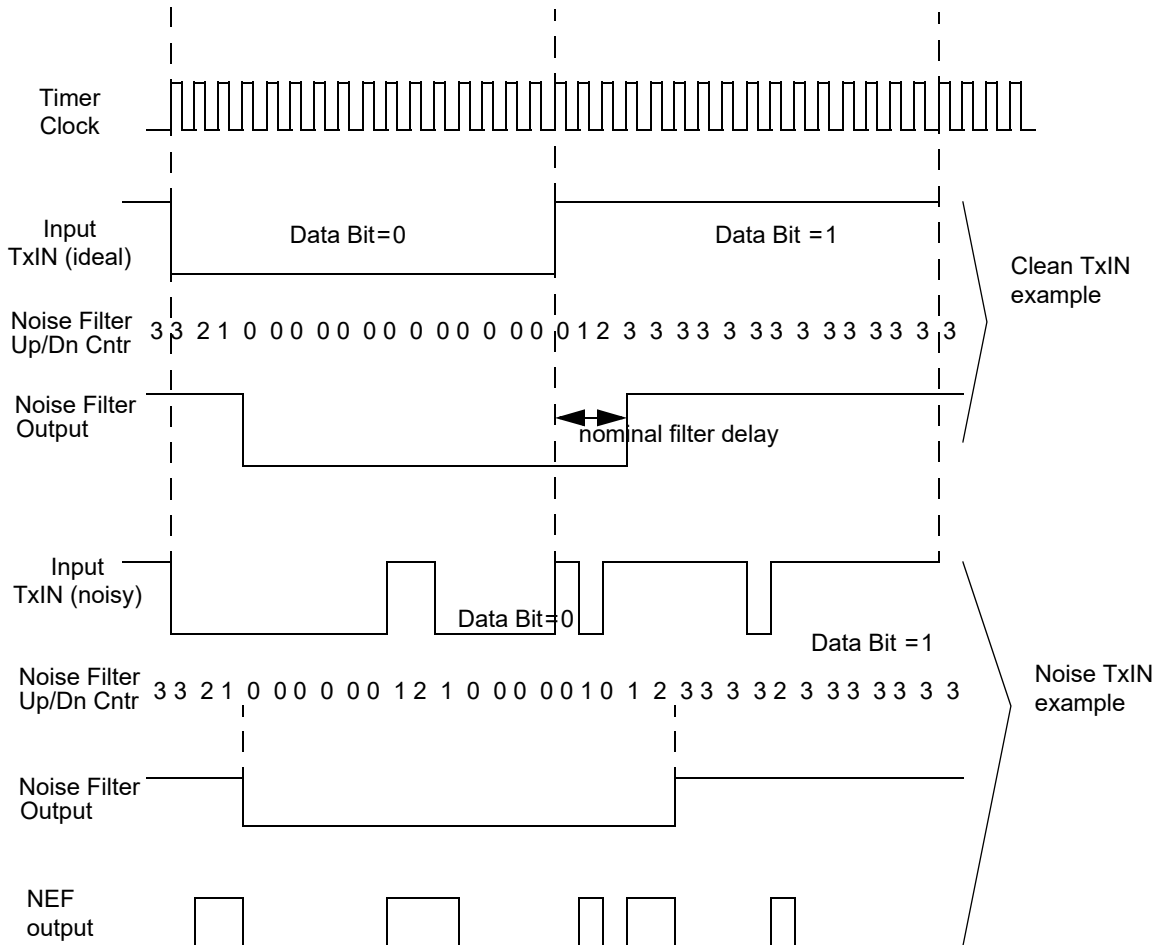

Figure 20. Noise Filter Operation

10.1. Timer Register Definitions

This section describes the following Timer registers.

- Timer 0–2 High and Low Byte Registers – [see page 175](#)
- Timer Reload High and Low Byte Registers – [see page 176](#)
- Timer 0–2 PWM0 High and Low Byte Registers – [see page 177](#)
- Timer 0–2 PWM1 High and Low Byte Registers – [see page 178](#)
- Timer 0–2 Control Registers – [see page 179](#)
- Timer 0–2 Status Registers – [see page 185](#)

- Timer 0–2 Noise Filter Control Registers – [see page 186](#)

10.1.1. Timer 0–2 High and Low Byte Registers

The Timer 0–2 High and Low Byte (TxH and TxL) registers, shown in Tables 75 and 76, contain the current 16-bit timer count value. When the timer is enabled, a read from TxH causes the value in TxL to be stored in a temporary holding register. A read from TxL always returns this temporary register when the timers are enabled. When the timer is disabled, reading from the TxL reads the register directly.

Zilog does not recommend writing to the Timer High and Low Byte registers when the timer is enabled. There are no temporary holding registers available for write operations; therefore simultaneous 16-bit writes are not possible. If either the Timer High or Low Byte registers are written during counting, the 8-bit written value is placed in the counter (High or Low Byte) at the next clock edge. The counter continues counting from the new value.

Table 75. Timer 0–2 High Byte Registers (TxH)

Bit	7	6	5	4	3	2	1	0
Field	TH							
Reset	0	0	0	0	0	0	0	0
R/W	R/W	R/W	R/W	R/W	R/W	R/W	R/W	R/W
Address	T0H @ F00h, T1H @ F08h, T2H @ F10h							
Note: x references bits in the range [2:0].								

Table 76. Timer 0–2 Low Byte Registers (TxL)

Bit	7	6	5	4	3	2	1	0
Field	TL							
Reset	0	0	0	0	0	0	0	1
R/W	R/W	R/W	R/W	R/W	R/W	R/W	R/W	R/W
Address	T0L @ F01h, T1L @ F09h, T2L @ F11h							
Note: x references bits in the range [2:0].								

Bit	Description
[7:0]	Timer High and Low Bytes
TH, TL	These 2 bytes, {TH[7:0], TL[7:0]}, contain the current 16-bit timer count value.

10.1.2. Timer Reload High and Low Byte Registers

The Timer 0–2 Reload High and Low Byte (TxRH and TxRL) registers, shown in Tables 77 and 78, store a 16-bit reload value, {TRH[7:0], TRL[7:0]}. Values written to these Timer Reload High Byte registers are stored in a temporary holding register. When a write to the Timer Reload Low Byte Register occurs, this temporary holding register value is written to the Timer High Byte Register. This operation allows simultaneous updates of the 16-bit timer reload value.

In Compare Mode, the Timer Reload High and Low Byte registers store the 16-bit Compare value.

Table 77. Timer 0–2 Reload High Byte Registers (TxRH)

Bit	7	6	5	4	3	2	1	0
Field	TRH							
Reset	1	1	1	1	1	1	1	1
R/W	R/W	R/W	R/W	R/W	R/W	R/W	R/W	R/W
Address	T0RH @ F02h, T1RH @ F0Ah, T2RH @ F12h							

Note: x references bits in the range [2:0].

Table 78. Timer 0–2 Reload Low Byte Registers (TxRL)

Bit	7	6	5	4	3	2	1	0
Field	TRL							
Reset	1	1	1	1	1	1	1	1
R/W	R/W	R/W	R/W	R/W	R/W	R/W	R/W	R/W
Address	T0RL @ F03h, T1RL @ F0Bh, T2RL @ F13h							

Note: x references bits in the range [2:0].

Bit	Description
[7:0] TRH, TRL	Timer Reload Register High and Low These two bytes form the 16-bit reload value, {TRH[7:0], TRL[7:0]}. This value is used to set the maximum count value which initiates a timer reload to 0001h. In Compare Mode, these two bytes form the 16-bit Compare value.

10.1.3. Timer 0–2 PWM0 High and Low Byte Registers

The Timer 0–2 PWM0 High and Low Byte (TxPWM0H and TxPWM0L) registers, shown in Tables 79 and 80, are used for Pulse Width Modulator (PWM) operations. These registers also store the Capture values for the Capture, Capture/Compare and Demodulation modes. When the timer is enabled, writes to these registers are buffered, and loading of the registers is delayed until a timer reload to 0001h occurs; i.e., unless PWM0UE=1.

Table 79. Timer 0–2 PWM0 High Byte Registers (TxPWM0H)

Bit	7	6	5	4	3	2	1	0
Field	PWM0H							
Reset	0	0	0	0	0	0	0	0
R/W	R/W	R/W	R/W	R/W	R/W	R/W	R/W	R/W
Address	T0PWM0H @ F04h, T1PWM0H @ F0Ch, T2PWM0H @ F14h							
Note: x references bits in the range [2:0].								

Table 80. Timer 0–2 PWM0 Low Byte Registers (TxPWM0L)

Bit	7	6	5	4	3	2	1	0
Field	PWM0L							
Reset	0	0	0	0	0	0	0	0
R/W	R/W	R/W	R/W	R/W	R/W	R/W	R/W	R/W
Address	T0PWM0L @ F05h, T1PWM0L @ F0Dh, T2PWM0L @ F15h							
Note: x references bits in the range [2:0].								

Bit	Description
[7:0]	Pulse Width Modulator 0 High and Low Bytes
PWM0H, PWM0L	These two bytes, {PWM0H[7:0], PWM0L[7:0]}, form a 16-bit value that is compared to the current 16-bit timer count. When a match occurs, the PWM output changes state. The PWM output value is set by the TPOL bit in the Timer Control 1 Register (TxCTL1). The TxPWM0H and TxPWM0L registers also store the 16-bit captured timer value when operating in Capture, Capture/Compare and Demodulation modes.

10.1.4. Timer 0–2 PWM1 High and Low Byte Registers

The Timer 0–2 PWM1 High and Low Byte (TxPWM1H and TxPWM1L) registers, shown in Tables 81 and 82, store Capture values for Demodulation Mode.

Table 81. Timer 0–2 PWM1 High Byte Registers (TxPWM1H)

Bit	7	6	5	4	3	2	1	0
Field	PWM1H							
Reset	0	0	0	0	0	0	0	0
R/W	R/W	R/W	R/W	R/W	R/W	R/W	R/W	R/W
Address	T0PWM1H @ F20h, T1PWM1H @ F24h, T2PWM1H @ F28h							
Note: x references bits in the range [2:0].								

Table 82. Timer 0–2 PWM1 Low Byte Registers (TxPWM1L)

Bit	7	6	5	4	3	2	1	0
Field	PWM1L							
Reset	0	0	0	0	0	0	0	0
R/W	R/W	R/W	R/W	R/W	R/W	R/W	R/W	R/W
Address	T0PWM1L @ F21h, T1PWM1L @ F25h, T2PWM1L @ F29h							
Note: x references bits in the range [2:0].								

Bit	Description
[7:0]	Pulse Width Modulator 1 High and Low Bytes
PWM1H, PWM1L	These two bytes, {PWM1H[7:0], PWM1L[7:0]}, store the 16-bit captured timer value for Demodulation Mode.

10.1.5. Timer 0–2 Control Registers

This subsection describes the three timer control registers.

10.1.5.1. Timer 0–2 Control 0 Register

The Timer 0–2 Control 0 (TxCTL0) registers, shown in Table 83, together with the TxCTL1 Register, determine the timer operating mode. These registers also include a programmable PWM deadband delay, two bits to configure timer interrupt definition and a status bit to identify if the last timer interrupt is due to an input capture event.

Table 83. Timer 0–2 Control 0 Registers (TxCTL0)

Bit	7	6	5	4	3	2	1	0
Field	TMODE[3]	TICONFIG		Reserved	PWMD			INPCAP
Reset	0	0	0	0	0	0	0	0
R/W	R/W	R/W	R/W	R/W	R/W	R/W	R/W	R
Address	T0CTL0 @ F06h, T1CTL0 @ F0Eh, T2CTL0 @ F16h							

Note: x references bits in the range [2:0].

Bit	Description
[7] TMODE[3]	<p>Timer Mode High Bit</p> <p>This bit, along with the TMODE[2:0] field in the TxCTL1 Register, determines the operating mode of the timer. This bit is the most significant bit of the timer mode selection value. To learn more, see the description of the Timer 0–2 Control 1 Registers section on page 180.</p>
[6:5] TICONFIG	<p>Timer Interrupt Configuration</p> <p>This field configures timer interrupt definition. This bit is a function of TMODE.</p> <p>All TMODE selections except Triggered One-Shot and Dual Input Triggered One-Shot modes.</p> <p>0x: Timer Interrupt occurs on all Reload, Compare and Input Events available in the selected mode.</p> <p>10: Timer Interrupt only on Input Capture/Deassertion Events available in the selected mode.</p> <p>11: Timer Interrupt only on Reload/Compare Events available in the selected mode.</p> <p>Triggered One-Shot Mode.</p> <p>00: All Reload Events and Trigger while counting.</p> <p>01: Only on timer Input 0 Trigger Events while counting.</p> <p>10: Only on timer Input 1 Trigger Events while counting.</p> <p>11: Only on Reload Events.</p> <p>Dual Input Triggered One-Shot Mode</p> <p>00: All Reload and Trigger while counting Events.</p> <p>01: Only on same input Trigger Events while counting.</p> <p>10: Only on input Trigger Events while counting by the input that did not trigger counting.</p> <p>11: Only on Reload Events.</p>

Bit	Description (Continued)
[4]	Reserved.
[3:1] PWMD	<p>PWM Delay Value This field is a programmable delay to control the number of timer clock cycles time delay before the Timer Output and the Timer Output Complement is forced to their active state. 000: No delay. 001: 2 cycles delay. 010: 4 cycles delay. 011: 8 cycles delay. 100: 16 cycles delay. 101: 32 cycles delay. 110: 64 cycles delay. 111: 128 cycles delay.</p>
[0] INPCAP	<p>Input Capture Event This bit should be ignored when TICONFIG=1x. 0: A reload occurred more recently than an Input Trigger, Timer Input Capture or Gate Deassertion Event. 1: An Input Trigger, Timer Input Capture or Gate Deassertion Event occurred more recently than reload.</p>

10.1.5.2. Timer 0–2 Control 1 Registers

The Timer 0–2 Control 1 (TxCTL1) registers, shown in Table 84, enable and disable the timers, set the prescaler value, and determine the timer operating mode.

Table 84. Timer 0–2 Control 1 Registers (TxCTL1)

Bit	7	6	5	4	3	2	1	0
Field	TEN	TPOL	PRES			TMODE		
Reset	0	0	0	0	0	0	0	0
R/W	R/W	R/W	R/W	R/W	R/W	R/W	R/W	R/W
Address	T0CTL1 @ F07h, T1CTL1 @ F0Fh, T2CTL1 @ F17h							
Note: x references bits in the range [2:0].								

Bit	Description
[7] TEN	<p>Timer Enable 0=Timer is disabled. 1=Timer enabled to count.</p>
[6] TPOL	<p>Timer Input/Output Polarity Operation of this field is a function of the current operating modes of the timer. One-Shot Mode When the timer is disabled, the Timer Output signal is set to the value of this bit. When the timer is enabled, the Timer Output signal is complemented upon timer reload.</p>

Bit	Description (Continued)
<p>[6] TPOl (cont'd)</p>	<p>Continuous Mode When the timer is disabled, the Timer Output signal is set to the value of this bit. When the timer is enabled, the Timer Output signal is complemented upon timer reload.</p> <p>Counter Mode When the timer is disabled, the Timer Output signal is set to the value of this bit. When the timer is enabled, the Timer Output signal is complemented upon timer reload. 0: Count occurs on the rising edge of the Timer Input 0 signal. 1: Count occurs on the falling edge of the Timer Input 0 signal.</p> <p>PWM Single Output Mode 0: Timer Output is forced Low (0) when the timer is disabled. When enabled, the Timer Output is forced High (1) on PWM count match and forced Low (0) on Reload. 1: Timer Output is forced High (1) when the timer is disabled. When enabled, the Timer Output is forced Low (0) on PWM count match and forced High (1) on Reload.</p> <p>Capture Mode 0: Count is captured on the rising edge of the Timer Input 0 signal. 1: Count is captured on the falling edge of the Timer Input 0 signal.</p> <p>Compare Mode When the timer is disabled, the Timer Output signal is set to the value of this bit. When the timer is enabled, the Timer Output signal is complemented on timer reload.</p> <p>Gated Mode 0: Timer counts when the Timer Input 0 signal is High (1) and interrupts are generated on the falling edge of the Timer Input 0 signal. 1: Timer counts when the Timer Input 0 signal is Low (0) and interrupts are generated on the rising edge of the Timer Input 0 signal.</p> <p>Capture/Compare Mode 0: Counting is started on the first rising edge of the Timer Input 0 signal. The current count is captured on subsequent rising edges of the Timer Input 0 signal. 1: Counting is started on the first falling edge of the Timer Input 0 signal. The current count is captured on subsequent falling edges of the Timer Input 0 signal.</p>

Bit	Description (Continued)
[6] TPOL (cont'd)	<p>PWM Dual Output Mode</p> <p>0: Timer Output is forced Low (0) and Timer Output Complement is forced High (1) when the timer is disabled. When enabled, the Timer Output is forced High (1) upon PWM count match and forced Low (0) upon Reload. When enabled, the Timer Output Complement is forced Low (0) upon PWM count match and forced High (1) upon Reload. The PWMD field in Timer Control 0 Register is a programmable delay to control the number of cycles time delay before the Timer Output and the Timer Output Complement is forced to High (1).</p> <p>1: Timer Output is forced High (1) and Timer Output Complement is forced Low (0) when the timer is disabled. When enabled, the Timer Output is forced Low (0) upon PWM count match and forced High (1) upon Reload. When enabled, the Timer Output Complement is forced High (1) upon PWM count match and forced Low (0) upon Reload. The PWMD field in Timer Control 0 Register is a programmable delay to control the number of cycles time delay before the Timer Output and the Timer Output Complement is forced to Low (0).</p> <p>Capture Restart Mode</p> <p>0: Count is captured on the rising edge of the Timer Input 0 signal.</p> <p>1: Count is captured on the falling edge of the Timer Input 0 signal.</p> <p>Comparator Counter Mode</p> <p>When the timer is disabled, the Timer Output signal is set to the value of this bit. When the timer is enabled, the Timer Output signal is complemented upon timer reload.</p> <p>Triggered One-Shot Mode and Dual Input Triggered One-Shot Mode</p> <p>OUTCTL = 0</p> <p>0: Timer counting is triggered on the rising edge of the Timer Input 0 signal.</p> <p>1: Timer counting is triggered on the falling edge of the Timer Input 0 signal.</p> <p>OUTCTL = 1</p> <p>0: Timer counting is triggered on the rising edge of the Timer Input 0 signal.</p> <p>1: Reserved.</p> <p>Demodulation Mode</p> <p>This functionality applies only if TPOLHI bit in Timer Control 2 Register is 0. If TPOLHI bit is 1 then timer counting is triggered on any edge of the Timer Input 0 signal and the current count is captured on both edges. The current count is captured into PWM0 registers on rising edges and PWM1 registers on falling edges of the Timer Input 0 signal.</p> <p>0: Timer counting is triggered on the rising edge of the Timer Input 0 signal. The current count is captured into PWM0 High and Low byte registers on subsequent rising edges of the Timer Input 0 signal.</p> <p>1: Timer counting is triggered on the falling edge of the Timer Input 0 signal. The current count is captured into PWM1 High and Low byte registers on subsequent falling edges of the Timer Input 0 signal.</p>

Bit	Description (Continued)
[5:3] PRES	<p>Prescale Value</p> <p>The timer input clock is divided by 2PRES; PRES can be set from 0 to 7. The prescaler is reset each time the Timer is disabled. This insures proper clock division each time the Timer is restarted.</p> <p>000=Divide by 1 001=Divide by 2 010=Divide by 4 011=Divide by 8 100=Divide by 16 101=Divide by 32 110=Divide by 64 111=Divide by 128</p>
[2:0] TMODE[2:0]	<p>Timer Mode</p> <p>This field, along with the TMODE[3] bit in the TxCTL0 Register, determines the operating mode of the timer. TMODE[3:0] selects among the following modes:</p> <p>0000=One-Shot Mode. 0001=Continuous Mode. 0010=Counter Mode. 0011=PWM Single Output Mode. 0100=Capture Mode. 0101=Compare Mode. 0110=Gated Mode. 0111=Capture/Compare Mode. 1000=PWM Dual Output Mode. 1001=Capture Restart Mode. 1010=Dual Input Triggered One-Shot Mode. 1011=Triggered One-Shot Mode. 1100=Demodulation Mode.</p>

10.1.5.3. Timer 0–2 Control 2 Registers

The Timer 0–2 Control 2 (TxCTL2) registers, shown in Table 85, allow selection of timer clock source and control of timer input polarity in Demodulation Mode.

Table 85. Timer 0–2 Control 2 Registers (TxCTL2)

Bit	7	6	5	4	3	2	1	0
Field	Reserved		PWM0UE	TPOLHI	Reserved	OUTCTL	TCLKS	
Reset	0	0	0	0	0	0	0	0
R/W	R/W	R/W	R/W	R/W	R/W	R/W	R/W	R/W
Address	T0CTL2 @ F22h, T1CTL2 @ F26h, T2CTL2 @ F2Ah							

Note: x references bits in the range [2:0].

Bit	Description
[7:6]	Reserved These bits are reserved and must be programmed to 00.
[5]	PWM0 Update Enable PWM0UE This bit determines whether writes to the PWM0 High and Low Byte registers are buffered when TEN=1. Writes to these registers are not buffered when TEN=0, regardless of the value of this bit. 0: Writes to the Channel High and Low Byte registers are buffered when TEN=1 and only take affect on a timer reload to 0001h. 1: Writes to the Channel High and Low Byte registers are not buffered when TEN=1.
[4]	Timer Input/Output Polarity High Bit TPOLHI This bit determines if timer count is triggered and captured on both edges of the input signal. This applies only to Demodulation Mode. 0: Count is captured only on one edge in Demodulation Mode. In this case, edge polarity is determined by TPOL bit in the TxCTL1 Register. 1: Count is triggered on any edge and captured on both rising and falling edges of the Timer Input signal in Demodulation Mode.
[3]	Reserved This bit is reserved and must be programmed to 0.
[2]	Timer Output Control OUTCTL This bit determines timer output behavior and applies only to One-Shot, Triggered One-Shot, and Dual Input Triggered One-Shot modes. 0: Pulse at reload lasting one timer clock. 1: Pulse from start to reload. Use only when TPOL = 0.
[1:0]	Timer Clock Source TCLKS 00: System Clock. 01: Reserved. Defaults to System Clock. 10: PCLK. 11: WTO.

10.1.6. Timer 0–2 Status Registers

The Timer 0–2 Status (TxSTAT) Register, shown in Table 86, indicate PWM capture/compare event occurrences, overrun errors, noise event occurrences and reload time-out status.

Table 86. Timer 0–2 Status Register (TxSTAT)

Bit	7	6	5	4	3	2	1	0
Field	NEF	Reserved	PWM1EO	PWM0EO	RTOEF	Reserved	PWM1EF	PWM0EF
Reset	0	0	0	0	0	0	0	0
R/W	R/W	R/W	R/W	R/W	R/W	R/W	R/W	R/W
Address	T0STAT @ F23h, T1STAT @ F27h, T2STAT @ F2Bh							

Bit	Description
[7] NEF	Noise Event Flag This status is applicable only if the Timer Noise Filter is enabled. The NEF bit will be asserted if digital noise is detected on the Timer Input 0 when the data is being sampled (center of bit time). If this bit is set, it does not mean that the timer input data is corrupted (though it can be in extreme cases), just that one or more Noise Filter data samples near the center of the bit time did not match the average data value.
[6]	Reserved This bit is reserved and must be programmed to 0.
[5:4] PWMxEO	PWM x Event Overrun This bit indicates that an overrun error has occurred. An overrun occurs when a new capture/compare event occurs before the previous PWMxEF bit is cleared. Clearing the associated PWMxEF bit in the TxSTAT Register clears this bit. 0: No Overrun. 1: Capture/Compare Event Flag Overrun.
[3] RTOEF	Reload Time-Out Event Flag This flag is set if timer counts up to the reload value and is reset to 0001h. Software can use this bit to determine if a reload occurred prior to a capture. It can also determine if timer interrupt is due to a reload event. 0: No Reload Time-Out event occurred. 1: A Reload Time-Out event occurred.
[2]	Reserved This bit is reserved and must be programmed to 0.
[1:0] PWMxEF	PWM x Event Flag This bit indicates if a capture/compare event occurred for this PWM channel. Software can use this bit to determine the PWM channel responsible for generating the timer interrupt. This event flag is cleared by writing a 1 to the bit. These bits will be set when an event occurs independent of the setting of the timer interrupt enable bit. 0: No Capture/Compare Event occurred for this PWM channel. 1: A Capture/Compare Event occurred for this PWM channel.

10.1.7. Timer 0–2 Noise Filter Control Registers

The Timer 0–2 Noise Filter Control (TxNFC) registers, shown in Table 87, enable and disable the Timer Noise Filter and set noise filter control.

Table 87. Timer 0–2 Noise Filter Control Registers (TxNFC)

Bit	7	6	5	4	3	2	1	0
Field	NFCTL				NFCON	Reserved		
Reset	0	0	0	0	0	0	0	0
R/W	W				W	R		
Address	T0NFC @ F2Ch, T1NFC @ F2Dh, T2NFC @ F2Eh							

Note: x references bits in the range [2:0].

Bit	Description
[7:4] NFCTL	<p>Noise Filter Control</p> <p>This field controls the delay and noise rejection characteristics of the Noise Filter. The wider the counter the more delay that is introduced by the filter and the wider the noise event that will be filtered.</p> <p>0000: The Noise Filter is disabled. Received inputs bypass the filter 0001: 2-bit up/down counter 0010: 3-bit up/down counter 0011: 4-bit up/down counter 0100: 5-bit up/down counter 0101: 6-bit up/down counter 0110: 7-bit up/down counter 0111: 8-bit up/down counter 1000: 9-bit up/down counter 1001: 10-bit up/down counter 1010: 11-bit up/down counter 1011–1111: Reserved.</p>
[3] NFCON	<p>Noise Filter Connection</p> <p>0: Noise Filter connects to Timer(x) and filters timer Input 0 (TxIN ORed with Event System Timer(x) Input 0). 1: Noise Filter is reassigned to Timer(x+1) and filters Event System Timer(x+1) Input 1. Timer(x) Input 0 effectively bypasses the Noise Filter. In the case of Timer 2, its Noise Filter connects to Timer 0 Input 1. With this selection, the Noise Filter is reassigned to the designated timer and uses its timer clock.</p>
[2:0]	<p>Reserved</p> <p>This bit is reserved and must be programmed to 0.</p>

Chapter 11. Multi-Channel Timer

The Multi-Channel timer has a 16-bit up/down counter and a 4-channel Capture/Compare/PWM channel array. This timer provides multiple synchronous Capture/Compare/PWM channels based on a single timer. The Multi-Channel Timer features include:

- 16-bit up/down timer counter with programmable prescale
- Selectable clock source (system clock or external input pin)
- Count Modulo and Count up/down counter modes
- Four independent capture/compare channels which reference the common timer
- Channel modes:
 - One-Shot Compare Mode
 - Continuous Compare Mode
 - PWM Output Mode
 - Capture Mode
- Event System and external input pin for timer input
- DMA request source

11.1. Architecture

Figure 21 shows the Multi-Channel Timer architecture.

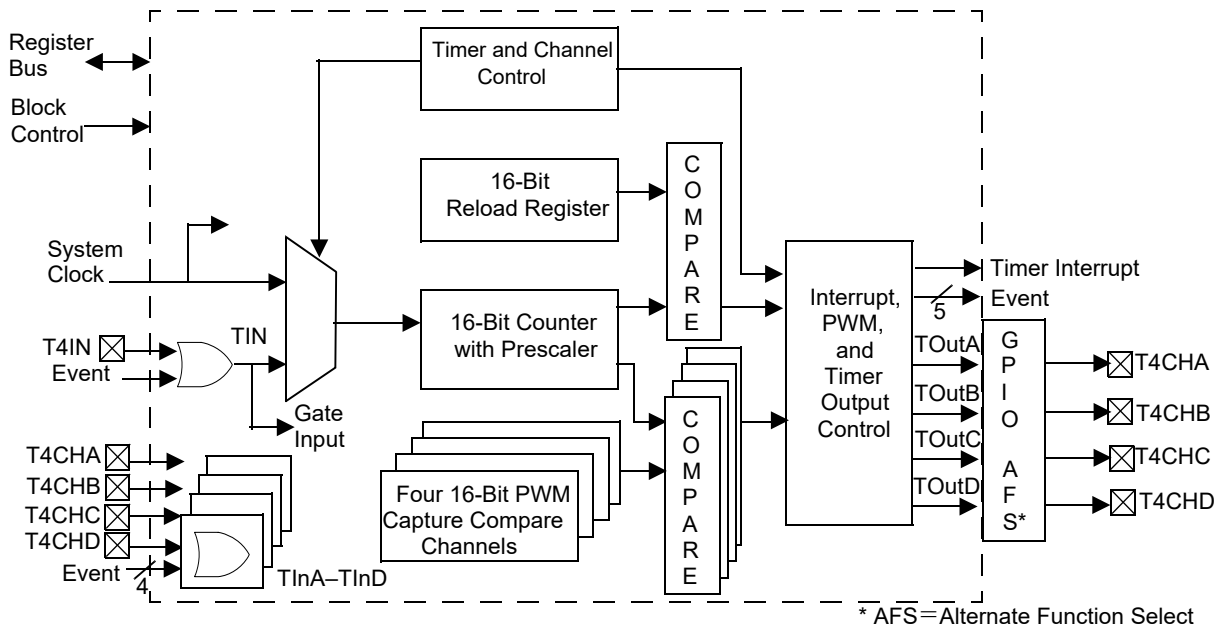

Figure 21. Multi-Channel Timer Block Diagram

11.2. Timer Operation

11.2.1. Multi-Channel Timer Counter

The Multi-Channel Timer is based around a 16-bit up/down counter. The counter, depending on the timer mode, counts up or down with each rising edge of the clock signal. Timer Counter registers MCTH and MCTL can be read/written by software.

11.2.2. Inputs and Outputs

Each GPIO alternate function (T4CHA–T4CHD and T4IN) is logically ORed with a corresponding Event System signal to form an input to the Multi-Channel Timer. Typically, only one of these two signals, either the GPIO input or Event System input, is configured to be active at a given time. Any inactive input is held at logic 0. To learn more about selecting a GPIO input using GPIO alternate function registers, refer to the [General-Purpose Input/Output](#) chapter on page 55. For information regarding selecting an Event System input, refer to the [Event System](#) chapter on page 411.

Multi-Channel Timer outputs can drive a GPIO and/or be a source to the Event System. To learn more about selecting a GPIO as a Multi-Channel Timer output using GPIO alternate function registers, refer to the [General-Purpose Input/Output](#) chapter on page 55. For

information regarding selecting a Multi-Channel Timer output as an Event System source, refer to the [Event System](#) chapter on page 411.

11.2.3. Clock Source

The Multi-Channel Timer clock source can come from either the System Clock, the System Clock gated by the TIN input, or the TIN input pin operating as a clock input. The TCLKS field in the MCTCTL0 Register selects the timer clock source. When using the TIN input, the associated GPIO pin or Event System channel must be configured as an input to the timer. The TIN frequency cannot exceed one-fourth the system clock frequency.

11.2.4. Multi-Channel Timer Clock Prescaler

The prescaler allows the system clock signal to be decreased by factors of 1, 2, 4, 8, 16, 32, 64, or 128. The PRES[2:0] bit field in the MCTCTL1 Register controls prescaler operation. The PRES field is buffered so that the prescale value is updated only on a MCT end-of-cycle count. The prescaler has no effect when the TIN input is selected as the clock source.

11.2.5. Multi-Channel Timer Start

The Multi-Channel Timer starts counting when TEN bit in MCTCTL1 Register is set and the clock source is active. Timer counting can be stopped without disabling the timer by setting the Reload Register to 0. The timer will then stop when the counter next reaches 0. Writing a nonzero value to the Reload Register restarts the timer counting.

11.2.6. Multi-Channel Timer Mode Control

The Multi-Channel Timer supports two modes of operation: Count Modulo and Count up/down. The timer operating mode is selected with the TMODE[1:0] field in the MCTCTL1 Register. The timer modes are described below in Table 88.

Table 88. Timer Count Modes

TMODE	Timer Mode	Description
00	Count Modulo	Timer counts up to Reload Register value. Then it is reset to 0000h and counting resumes.
01	Reserved	
10	Count Up/Down	Timer counts up to Reload and then counts down to 0000h. The Count up/down cycle continues.
11	Reserved	

11.2.7. Count Modulo Mode

In the Count Modulo Mode, the Timer counts up to the Reload Register value (max value = FFFFh). Then it is reset to 0000h and counting resumes. As shown in Figure 22, the counting cycle continues with Reload + 1 as the period. A timer count interrupt request is generated when the timer count resets from Reload to 0000h. If Count Modulo is selected when the timer count is greater than Reload, the timer immediately restarts counting from zero.

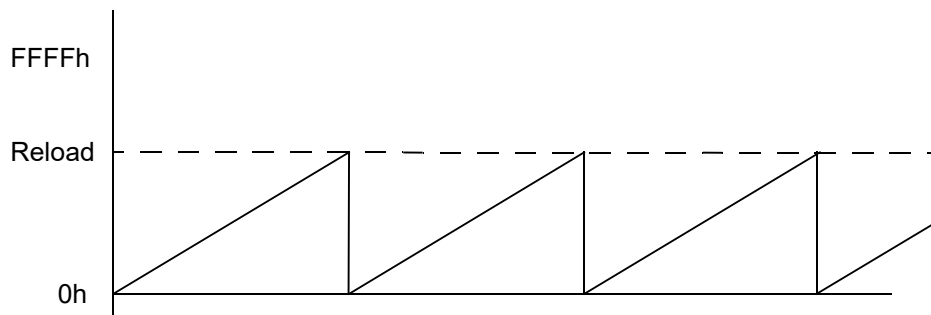

Figure 22. Count Modulo Mode

11.2.8. Count Up/Down Mode

In the Count Up/Down Mode, the timer counts up to the Reload Register value and then counts down to 0000h. As shown in Figure 23, the counting cycle continues with twice the reload value as the period. A timer count interrupt is generated when the timer count decrements to zero.

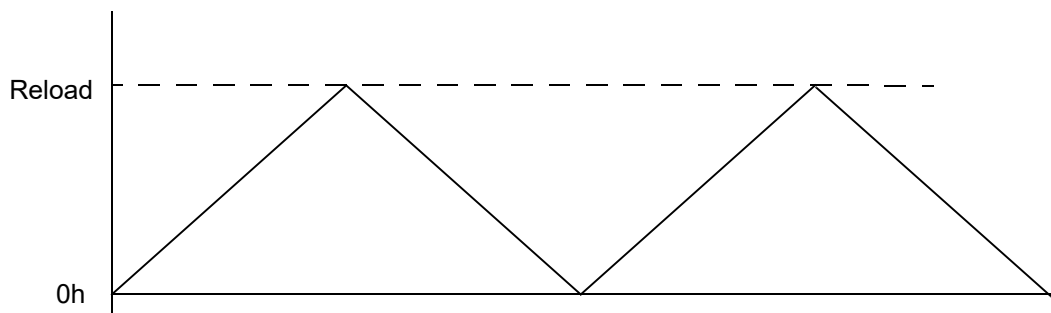

Figure 23. Count Up/Down Mode

11.3. Capture/Compare Channel Operation

The Multi-Channel timer supports four Capture/Compare channels: CHA, CHB, CHC, and CHD. Each channel has the following features:

- A 16-bit Capture/Compare Register (MCTCHyH and MCTCHyL registers) used to capture input event times or to generate time intervals. Any user software update of the Capture/Compare Register value when the timer is running takes effect only at the end of the counting cycle, not immediately. The end of the counting cycle is when the counter transitions from the reload value to 0 (Count Modulo Mode) or from 1 to 0 (Count Up/Down Mode).
- A dedicated bidirectional GPIO pin (T4CHA, B, C, or D) and Event System input/output that can be configured for the input capture function or to generate an output compare match or one-shot pulse.

Each channel is configured to operate in either One-Shot Compare, Continuous Compare, PWM Output, or Capture Mode.

11.3.1. One-Shot Compare Operation

In One-Shot Compare operation, a channel interrupt is generated when the channel compare value matches the timer count. The channel event flag, CHyEF, is set in the Channel Status 1 Register (MCTCHS1) to identify the responsible channel. Then the channel is automatically disabled. The timer continues counting according to the programmed mode. The channel output (TOutA, B, C, or D) changes state for one system clock cycle (from Low to High then back to Low or High to Low then back to High as determined by the CHPOL bit) on match.

11.3.2. Continuous Compare Operation

In Continuous Compare operation, a channel interrupt is generated when the channel compare value matches the timer count. The channel event flag (CHyEF) is set in the Channel Status1 Register (MCTCHS1) and the channel remains enabled. The timer continues counting according to the programmed mode. The channel output (TOutA, B, C, or D) changes state (from Low to High then back to Low, or High to Low then back to High as determined by the CHPOL bit) on match. For proper operation, configure the CHPOL bit prior to setting the CHEN bit.

11.3.3. PWM Output Operation

In PWM Output operation, the timer generates a PWM output signal on the channel output (TOutA, B, C, or D). The channel output toggles whenever the timer count matches the channel compare value (defined in the MCTCHyH and MCTCHyL) registers. In addition, a channel interrupt is generated and the channel event flag is set in the status register. The timer continues counting according to its programmed mode.

The channel output signal begins with the output value=CHPOL and then transitions to CHPOL when timer value matches the PWM value. If the timer mode is Count Modulo Mode, the channel output signal returns to output=CHPOL when timer reaches the reload value and is reset. If the timer mode is Count Up/Down Mode, channel output signal returns to output=CHPOL when the timer count matches the PWM value again (when counting down). For proper operation, configure the CHPOL bit prior to setting the CHEN bit.

11.3.4. Capture Operation

In Capture operation, the current timer count is recorded when the selected transition occurs on TInA, B, C or D. The Capture count value is written to the Channel High and Low Byte registers. In addition, a channel interrupt is generated and the channel event flag (CHyEF) is set in the Channel Status Register. The CHPOL bit in the Channel Control Register determines if the Capture occurs on a rising edge or a falling edge of the Channel Input signal. The timer continues counting according to the programmed mode.

11.4. Multi-Channel Timer Interrupts and DMA

The Multi-Channel Timer provides a single interrupt which has five possible sources. These sources are the internal timer and the four timer channels.

11.4.1. Timer Interrupt

If enabled by TCIE bit of the MCTCTL0 Register, the timer interrupt will be generated when the timer completes a count cycle. This occurs during transition from counter=reload register value to counter=0 in Count Modulo Mode, and occurs during transition from counter=1 to counter=0 in Count Up/Down Mode.

11.4.2. Channel Interrupts

If enabled by the CHIEN bit of the MCTCHyCTL Register, a channel interrupt is generated when the channel compare value matches the timer count while in one of the following channel modes: One-Shot Compare, Continuous Compare, or PWM Output.

In Capture operation, a channel interrupt is generated whenever there is a successful Capture Event on the Timer Channel.

11.4.3. DMA

DMA request is asserted whenever the MCT asserts interrupt request due to a channel interrupt. This provides a mechanism for DMA transfers to be triggered by the Timer. Each MCT DMA request results in a single-byte DMA transfer. DMA request is cleared when the DMA services the request or whenever the MCT channel is disabled. Zilog does

not recommend DMA for One-Shot Compare operation, because upon a channel interrupt, the channel is disabled, thereby clearing its DMA request.

- DMA request behavior is a function of channel mode. The behavior in the first paragraph under DMA would pertain to all modes except Capture Mode.

11.5. Low-Power Modes

11.5.1. Operation in Halt Mode

When the eZ8 CPU is operating in Halt Mode, the Multi-Channel Timer will continue to operate if enabled. To minimize current in Halt Mode, the Multi-Channel Timer must be disabled by clearing the TEN control bit.

11.5.2. Operation in Stop Mode

When the eZ8 CPU is operating in Stop Mode, the Multi-Channel Timer ceases to operate as the System Clock is stopped. The registers are not reset and operation will resume after Stop-Mode Recovery occurs.

11.5.3. Power Reduction During Operation

Deassertion of the TEN bit will inhibit clocking of the entire Multi-Channel Timer block. Deassertion of the CHEN bit of individual channels will inhibit clocking of channel specific logic to minimize power consumption of unused channels. The CPU can still read/write registers when the enable bit(s) are deasserted.

11.6. Multi-Channel Timer Application Examples

11.6.1. PWM Programmable Deadband Generation

The Count Up/Down Mode supports motor control applications that require dead time between output signals. Figure 24 shows dead-time generation between two channels operating in Count Up/Down Mode.

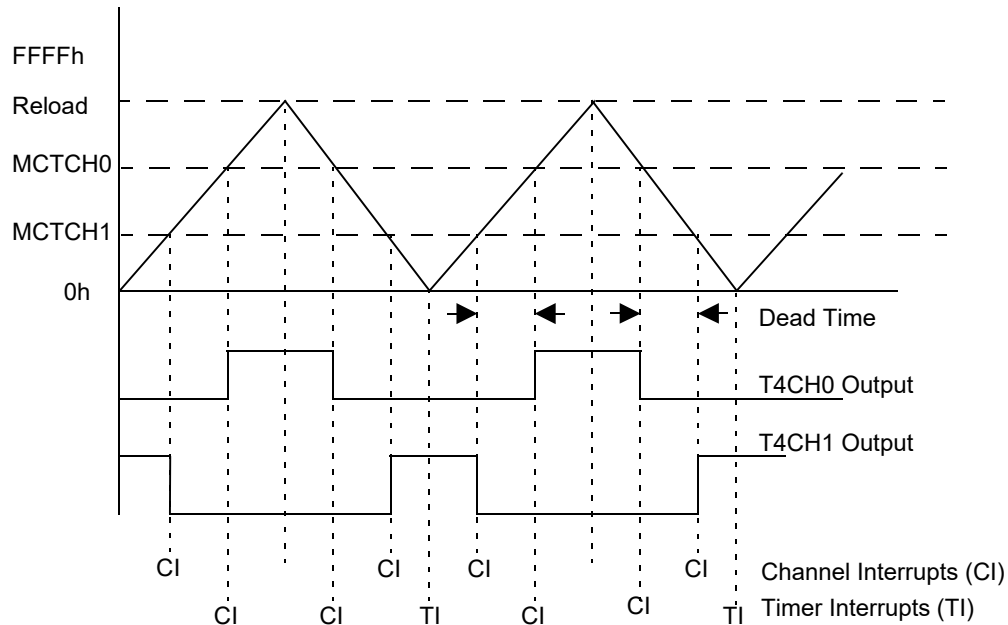

Figure 24. Count Up/Down Mode with PWM Channel Outputs and Deadband

11.6.2. Multiple Timer Intervals Generation

Figure 25 shows generation of two constant time intervals t_0 and t_1 . The timer is in Count Modulo Mode with reload=FFFFh. Channels 0 and 1 are set up for Continuous Compare operation. After every channel compare interrupt, the channel Capture/Compare registers are updated in the interrupt service routine by adding a constant equal to the time interval required. This operation requires that the Channel Update Enable (CHUE) bit must be set in channels 0 and 1 so that writes to the Capture/Compare registers take affect immediately.

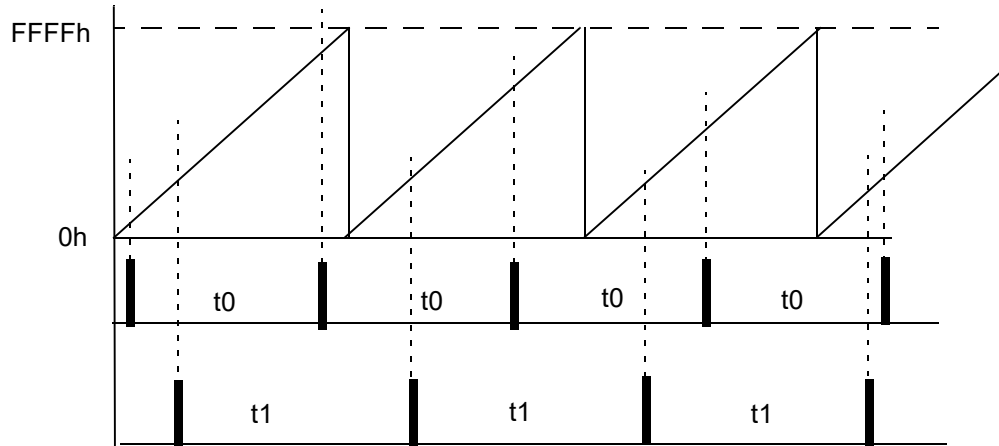

Figure 25. Count Max Mode with Channel Compare

11.7. Multi-Channel Timer Control Register Definitions

11.7.1. Multi-Channel Timer Address Map

Table 89 defines the byte address offsets for the Multi-Channel Timer registers. To save address space, a subaddress is used for the Timer Control 0, Timer Control 1, Channel Status 0, Channel Status 1, Channel-y Control, Channel-y High- and Low-Byte registers. Only the Timer High- and Low-Byte registers and the Reload High- and Low-Byte registers can be directly accessed.

While writing to a subregister, first write its subaddress to the Timer Subaddress Register, then write data to Subregister 0, Subregister 1, or Subregister 2. Reads function the same as writes.

Table 89. Multi-Channel Timer Address Map

Address/ Subaddress	Register/ Subregister Name
Direct Access Register	
FA0	Timer (Counter) High
FA1	Timer (Counter) Low
FA2	Timer Reload High
FA3	Timer Reload Low
FA4	Timer Subaddress
FA5	Subregister 0

Table 89. Multi-Channel Timer Address Map (Continued)

Address/ Subaddress	Register/ Subregister Name
FA6	Subregister 1
FA7	Subregister 2
Subregister 0	
0	Timer Control 0
1	Channel Status 0
2	Channel A Capture/Compare High
3	Channel B Capture/Compare High
4	Channel C Capture/Compare High
5	Channel D Capture/Compare High
Subregister 1	
0	Timer Control 1
1	Channel Status 1
2	Channel A Capture/Compare Low
3	Channel B Capture/Compare Low
4	Channel C Capture/Compare Low
5	Channel D Capture/Compare High
Subregister 2	
0	Reserved
1	Reserved
2	Channel A Control
3	Channel B Control
4	Channel C Control
5	Channel D Control

11.7.2. Multi-Channel Timer High and Low Byte Registers

The High and Low Byte (MCTH and MCTL) registers, shown in Tables 90 and 91, contain the current 16-bit MCT count value. Zilog does not recommend writing to the MCT High and Low Byte registers while the MCT is enabled. If either or both of the MCT High or Low Byte registers are written to during counting, the 8-bit written value is placed in the counter (High and/or Low byte) at the next system clock edge. The counter continues counting from the new value.

When MCT is enabled, a read from MCTH causes the value in MCTL to be stored in a temporary holding register. A read from MCTL returns this temporary register when MCT

is enabled. When MCT is disabled, reads from MCTL read the register directory. The MCT High and Low Byte registers are not reset when TEN=0.

Table 90. MCT High Byte Register (MCTH)

Bit	7	6	5	4	3	2	1	0
Field	MCTH							
RESET	0	0	0	0	0	0	0	0
R/W	R/W	R/W	R/W	R/W	R/W	R/W	R/W	R/W
Address	FA0h							

Table 91. MCT Low Byte Register (MCTL)

Bit	7	6	5	4	3	2	1	0
Field	MCTL							
RESET	0	0	0	0	0	0	0	0
R/W	R/W	R/W	R/W	R/W	R/W	R/W	R/W	R/W
Address	FA1h							

Bit	Description
[7:0] MCTH, MCTL	MCT High and Low Bytes These 2 bytes, {MCTH[7:0], MCTL[7:0]}, contain the current 16-bit MCT count value.

11.7.3. MCT Reload High and Low Byte Registers

The MCT Reload High and Low Byte (MCTRH and MCTRL) registers, shown in Tables 92 and 93, store a 16-bit reload value, {MCTRH[7:0], MCTRL[7:0]}. When TEN=0, writes to this address update the register on the next clock cycle. When TEN=1, writes to this register are buffered and transferred into the register when the counter reaches the end of the count cycle.

$$\text{Modulo Mode Period} = \frac{\text{Prescale Value} \times (\text{Reload Value} + 1)}{f_{\text{MCTCLK}}}$$

$$\text{Up/Down Mode Period} = \frac{2 \times \text{Prescale Value} \times \text{Reload Value}}{f_{\text{MCTCLK}}}$$

A value written to the MCTRH is stored in a temporary holding register. When a write to the MCTRL occurs, the temporary holding register value is written to the MCTRH. This operation allows simultaneous updates of the 16-bit MCT reload value.



Table 92. MCT Reload High Byte Register (MCTRH)

Bit	7	6	5	4	3	2	1	0
Field	MCTRH							
RESET	1	1	1	1	1	1	1	1
R/W	R/W	R/W	R/W	R/W	R/W	R/W	R/W	R/W
Address	FA2h							

Table 93. MCT Reload Low Byte Register (MCTRL)

Bit	7	6	5	4	3	2	1	0
Field	MCTRL							
RESET	1	1	1	1	1	1	1	1
R/W	R/W	R/W	R/W	R/W	R/W	R/W	R/W	R/W
Address	FA3h							

Bit	Description
[7:0] MCTRH, MCTRL	MCT Reload Register High and Low These two bytes form the 16-bit reload value, {MCTRH[7:0], MCTRL[7:0]}. This value sets the MCT period in the Modulo and Up/Down Count modes.

11.7.4. MCT Subaddress Register

The MCT Subaddress Register, shown in Table 94, stores 3-bit subaddresses for subregisters. These three bits are from MCTSA[2:0], all other bits are reserved. When accessing a subregister (writing or reading), first write MCTSA with the subregister address, then access the subregister by writing or reading subregisters 0, 1, or 2.

Table 94. MCT Subaddress Register (MCTSA)

Bit	7	6	5	4	3	2	1	0
Field	Reserved					MCTSA		
RESET	0	0	0	0	0	0	0	0
R/W	R	R	R	R	R	R/W	R/W	R/W
Address	FA4h							

11.7.5. MCT Subregister x

The MCT Subregister x, in which x = 0, 1, or 2 (see Table 95), stores an 8-bit data write to a subregister or an 8-bit data read from a subregister. The MCT Subaddress Register selects the subregister to be written to or read from.

Table 95. MCT Subregister x (MCTSRx)

Bit	7	6	5	4	3	2	1	0
Field	MCTSRx							
RESET	X	X	X	X	X	X	X	X
R/W	R/W	R/W	R/W	R/W	R/W	R/W	R/W	R/W
Address	MCTSR0 @ FA5h, MCTSR1 @ FFA6h, MCTSR2 @ FFA7h							

Note: x references bits in the range [2:0].

Bit	Description
-----	-------------

[7:0] MCTSRx	
-----------------	--

11.7.6. Multi-Channel Timer Control 0 and Control 1 Registers

The Multi-Channel Timer Control 0 and 1 registers (MCTCTL0, MCTCTL1), shown in Tables 96 and 97, control multi-channel timer operation. Writes to the PRES field of the MCTCTL1 Register are buffered when TEN=1, and will not take effect until the next end-of-cycle count occurs.

Table 96. Multi-Channel Timer Control 0 Register (MCTCTL0)

Bit	7	6	5	4	3	2	1	0
Field	TCTST	CHST	TCIEN	Reserved		TCLKS		
RESET	0	0	0	0	0	0	0	0
R/W	R/W1C	R	R/W	R	R	R/W	R/W	R/W
Address	00h in Subaddress Register, accessible through Subregister 0							

Bit	Description
-----	-------------

[7] TCTST	<p>Timer Count Status</p> <p>This bit indicates if a timer count cycle is complete and is cleared by writing 1 to the bit and is cleared when TEN=0.</p> <p>0: Timer count cycle is not complete.</p> <p>1: Timer count cycle is complete.</p>
--------------	---

Bit	Description (Continued)
[6] CHST	<p>Channel Status</p> <p>This bit indicates if a channel Capture/Compare event occurred. This bit is the logical OR of the CHyEF bits in the MCTCHS1 Register. This bit is cleared when TEN=0.</p> <p>0: No channel capture/compare event has occurred.</p> <p>1: A channel capture/compare event has occurred. One or more of the CHDEF, CHCEF, CHBEF, and CHAEF bits in the MCTCHS1 Register are set.</p>
[5] TCIEN	<p>Timer Count Interrupt Enable</p> <p>This bit enables generation of timer count interrupt. A timer count interrupt is generated whenever the timer completes a count cycle: counting up to Reload Register value or counting down to zero depending on whether the timer mode is Count Modulo or Count up/down.</p> <p>0: Timer Count Interrupt is disabled.</p> <p>1: Timer Count Interrupt is enabled.</p>
[4:3]	<p>Reserved</p> <p>These bits are reserved and must be programmed to 00.</p>
[2:0] TCLKS	<p>Timer Clock Source</p> <p>000: System Clock (prescaling enabled).</p> <p>001: Reserved.</p> <p>010: System Clock gated by active High Timer Input signal (Prescaling enabled).</p> <p>011: System Clock gated by active Low Timer Input signal (Prescaling enabled).</p> <p>100: Timer input rising edge (Prescaler disabled).</p> <p>101: Timer input falling edge (Prescaler disabled).</p> <p>110: Reserved.</p> <p>111: Reserved.</p>

► **Note:** The input frequency of the timer input signal must not exceed one-fourth of the system clock frequency.

Table 97. Multi-Channel Timer Control 1 Register (MCTCTL1)

Bit	7	6	5	4	3	2	1	0
Field	TEN	Reserved	PRES			Reserved	TMODE	
RESET	0	0	0	0	0	0	0	0
R/W	R/W	R	R/W	R/W	R/W	R	R/W	R/W
Address	00h in Subaddress Register, accessible through Subregister 1							

Bit	Description
[7] TEN	Timer Enable 0: Timer is disabled and the counter is reset. 1: Timer is enabled to count.
[6]	Reserved This bit is reserved and must be programmed to 0.
[5:3] PRES	Prescale Value The system clock is divided by the value selected in PRES. The prescaling operation is not applied when the alternate function input pin is selected as the timer clock source. 000: Divide by 1. 001: Divide by 2. 010: Divide by 4. 011: Divide by 8. 100: Divide by 16. 101: Divide by 32. 110: Divide by 64. 111: Divide by 128.
[2]	Reserved This bit is reserved and must be programmed to 0.
[1:0] TMODE	Timer Mode 00: Count Modulo: the timer counts up to the reload register value, then is reset to 0000h, and counting up resumes. 01: Reserved. 10: Count up/down: the timer counts up to the reload register value, then counts down to 0000h. The count up and count down cycles continue. 11: Reserved.

11.7.7. Multi-Channel Timer Channel Status 0 and Status 1 Registers

The Multi-Channel Timer Channel Status 0 and Status 1 Registers (MCTCHS0, MCTCHS1), shown in Tables 98 and 99, indicate channel overrun and channel capture/compare events.

Table 98. Multi-Channel Timer Channel Status 0 Register (MCTCHS0)

Bit	7	6	5	4	3	2	1	0
Field	Reserved				CHDEO	CHCEO	CHBEO	CHAE0
RESET	0	0	0	0	0	0	0	0
R/W	R	R	R	R	R	R	R	R
Address	01h in Subaddress Register, accessible through Subregister 0							

Bit	Description
[7:4]	Reserved These bits are reserved and must be programmed to 0000.
[3:0] CHyEO	Channel y Event Flag Overrun This bit indicates that an overrun error has occurred. An overrun occurs when a new Capture/Compare event occurs before the previous CHyEF bit is cleared. Clearing the associated CHyEF bit in the MCTCHS1 Register clears this bit. This bit is also cleared when TEN=0 (TEN is the MSB of MCTCTL1). 0: No Overrun. 1: Capture/Compare Event Flag Overrun.

Note: y = A, B, C, D.

Table 99. Multi-Channel Timer Channel Status 1 Register (MCTCHS1)

Bit	7	6	5	4	3	2	1	0
Field	Reserved				CHDEF	CHCEF	CHBEF	CHAEF
RESET	0	0	0	0	0	0	0	0
R/W	R	R	R	R	R/W1C	R/W1C	R/W1C	R/W1C
Address	01h in Subaddress Register, accessible through Subregister 1							

Bit	Description
[7:4]	Reserved These bits are reserved and must be programmed to 0000.

Note: y = A, B, C, D.

Bit	Description (Continued)
[3:0] CHyEF	<p>Channel y Event Flag</p> <p>This bit indicates whether a Capture/Compare event occurred for this channel. Software can use this bit to determine the channel(s) responsible for generating the MCT channel interrupt. This event flag is cleared by writing a 1 to the bit. These bits will be set when an event occurs independently of the setting of the CHIEN bit. This bit is cleared when TEN=0 (TEN is the MSB of MCTCTL1).</p> <p>0: No Capture/Compare event occurred for this channel. 1: A Capture/Compare event occurred for this channel.</p>

Note: y = A, B, C, D.

11.7.8. Multi-Channel Timer Channel-y Control Registers

Each channel in the Multi-Channel Timer Channel-y Control registers, shown in Table 100, has a control register to enable the channel, select the input/output polarity, enable channel interrupts, and select the channel mode of operation.

Table 100. Multi-Channel Timer Channel Control Register (MCTCHyCTL)

Bit	7	6	5	4	3	2	1	0
Field	CHEN	CHPOL	CHIEN	CHUE	Reserved	CHOP		
RESET	0	0	0	0	0	0	0	0
R/W	R/W	R/W	R/W	R/W	R	R/W	R/W	R/W
Address	02h, 03h, 04h, 05h in Subaddress Register, accessible through Subregister 2							

Bit	Description
[7] CHEN	<p>Channel Enable</p> <p>0: Channel is disabled. 1: Channel is enabled.</p>

Note: y = A, B, C, D.

Bit	Description (Continued)
[6] CHPOL	<p>Channel Input/Output Polarity Operation of this bit is a function of the current operating mode of the channel. For Continuous Compare and PWM Output operation, configure this bit prior to setting the CHEN bit.</p> <p>One-Shot Operation When the channel is disabled, the Channel Output signal is set to the value of this bit. When the channel is enabled, the Channel Output signal toggles for one system clock on reaching the Channel Capture/Compare Register value.</p> <p>Continuous Compare Operation When the channel is disabled, the Channel Output signal is set to the value of this bit. When the channel is enabled, the Channel Output signal toggles (from Low to High or High to Low) on reaching the Channel Capture/Compare Register value.</p> <p>PWM Output Operation 0: Channel Output is forced Low when the channel is disabled. When enabled, the Channel Output is forced High on Channel Capture/Compare Register value match and forced Low on reaching the Timer Reload Register value (Modulo Mode) or counting down through the channel Capture/Compare register value (Count Up/Down Mode). 1: Channel Output is forced Low when the channel is disabled. When enabled, the Channel Output is forced High on Channel Capture/Compare Register value match and forced Low on reaching the Timer Reload Register value (Modulo Mode) or counting down through the channel Capture/Compare register value (Count Up/Down Mode).</p> <p>Capture Operation 0: Count is captured on the rising edge of the Channel Input signal. 1: Count is captured on the falling edge of the Channel Input signal.</p>
[5] CHIEN	<p>Channel Interrupt Enable This bit enables generation of channel interrupt. A channel interrupt is generated whenever there is a capture/compare event on the Timer Channel. 0: Channel interrupt is disabled. 1: Channel interrupt is enabled.</p>
[4] CHUE	<p>Channel Update Enable This bit determines whether writes to the Channel High and Low Byte registers are buffered when TEN=1. Writes to these registers are not buffered when TEN=0 regardless of the value of this bit. 0: Writes to the Channel High and Low Byte registers are buffered when TEN=1, and only take affect on the next end-of-cycle count. 1: Writes to the Channel High and Low Byte registers are not buffered when TEN=1.</p>
[3]	<p>Reserved This bit is reserved and must be programmed to 0.</p>

Note: y = A, B, C, D.

Bit	Description (Continued)
[2:0] CHOP	Channel Operation Mode This field determines the operating mode of the channel. For a description of the operating modes, see the Count Up/Down Mode section on page 190. 00: One-Shot Compare. 001: Continuous Compare. 010: PWM Output. 011: Capture. 100–111: Reserved.

Note: y = A, B, C, D.

11.7.9. Multi-Channel Timer Channel-y High and Low Byte Registers

Each channel has a 16-bit capture/compare register defined here as the Channel-y High and Low Byte registers. When the timer is enabled, writes to these registers are buffered and loading of the registers is delayed till the next timer end count, unless CHUE=1.

Table 101. Multi-Channel Timer Channel-y High Byte Registers (MCTCHyH)

Bit	7	6	5	4	3	2	1	0
Field	CHyH							
RESET	0	0	0	0	0	0	0	0
R/W	R/W	R/W	R/W	R/W	R/W	R/W	R/W	R/W
Address	02h, 03h, 04h, 05h in Subaddress Register, accessible through Subregister 0							

Table 102. Multi-Channel Timer Channel-y Low Byte Registers (MCTCHyL)

Bit	7	6	5	4	3	2	1	0
Field	CHyL							
RESET	0	0	0	0	0	0	0	0
R/W	R/W	R/W	R/W	R/W	R/W	R/W	R/W	R/W
Address	02h, 03h, 04h, 05h in Subaddress Register, accessible through Subregister 1							

Bit	Description
[7:0] CHyH, CHyL	Multi-Channel Timer Channel-y High and Low Bytes During a compare operation, these two bytes, {CHyH[7:0], CHyL[7:0]}, form a 16-bit value that is compared to the current 16-bit timer count. When a match occurs, the Channel Output changes state. The Channel Output value is set by the CHPOL bit in the Channel-y Control subregister. During a capture operation, the current Timer Count is recorded in these two bytes when the desired Channel Input transition occurs.

Note: y = A, B, C, D.

Chapter 12. Watchdog Timer

The Watchdog Timer (WDT) function helps protect against corrupted or unreliable software and other system-level problems that can place the F6482 Series MCU into unsuitable operating states. The WDT includes the following features:

- Clocked by the Watchdog Timer Oscillator (WTO)
- A selectable time-out response: System Reset or Interrupt
- 16-bit programmable time-out value

12.1. Operation

The WDT is a retriggerable one-shot timer that resets or interrupts the F6482 Series MCU when the WDT reaches its terminal count. The WDT uses the Watchdog Timer Oscillator (WTO) as its clock source. The WDT has only two modes of operation: ON and OFF. After it is enabled, the WDT always counts and must be retriggered to prevent a time-out. An enable can be performed by executing the WDT instruction or by writing the WDT_AO option bit to 0. When 0, The WDT_AO bit enables the WDT to operate continuously, even if a WDT instruction has not been executed.

The WDT is a 16-bit reloadable downcounter that uses two 8-bit registers in the eZ8 CPU register space to set the reload value. The nominal WDT time-out period is calculated using the following equation:

$$\text{WDT Time-Out Period (ms)} = \frac{\text{WDT Reload Value}}{10}$$

In the above equation, the WDT reload value is computed using {WDTH[7:0], WDTL[7:0]} and the typical Watchdog Timer RC Oscillator frequency is 10 kHz. Users must consider system requirements when selecting the time-out delay. Table 103 indicates the approximate time-out delays for the default and maximum WDT reload values.

Table 103. Watchdog Timer Approximate Time-Out Delays

WDT Reload Value (Hex)	WDT Reload Value (Decimal)	Approximate Time-Out Delay (with 10kHz Typical WDT Oscillator Frequency)	
		Typical	Description
0400	1024	102 ms	Reset default value time-out delay.
FFFF	65,536	6.55s	Maximum time-out delay.

12.1.1. Watchdog Timer Retrigger

When first enabled, the WDT is loaded with the value in the WDT Reload registers. The WDT then counts down to 0000h unless a WDT instruction is executed by the eZ8 CPU. Execution of the WDT instruction causes the downcounter to be reloaded with the WDT reload value stored in the WDT Reload registers. Counting resumes following the reload operation.

When the eZ8 CPU is operating in DEBUG Mode (through the OCD), the WDT is continuously retrIGGERED to prevent unnecessary WDT time-outs.

12.1.2. Watchdog Timer Time-Out Response

The WDT times out when the counter reaches 0000h. A time-out of the WDT generates either an interrupt or a System Reset. The WDT_RES option bit determines the time-out response of the WDT. To learn more about programming the WDT_RES option bit, see the [Flash Option Bits](#) chapter on page 542.

12.1.2.1. WDT Interrupt in Normal Operation

If it is configured to generate an interrupt when a time-out occurs, the WDT issues an interrupt request to the Interrupt Controller. The WDT status bit in the Reset Status Register is set. The eZ8 CPU responds to the request by fetching the corresponding interrupt vector and executing code from the vector address. After time-out and interrupt generation, the WDT rolls over and continues counting. To clear the WDT interrupt, clear the WDT bit in the Reset Status Register.

12.1.2.2. WDT Interrupt in Stop Mode

The WDT automatically initiates a Stop-Mode Recovery and generates an interrupt request if configured to generate an interrupt when a time-out occurs and the CPU is in Stop Mode. Both the WDT status bit and the STOP bit in the Reset Status Register are set to 1 following a WDT time-out in Stop Mode. After time-out and interrupt generation, the WDT rolls over and continues counting.

Upon completion of the Stop-Mode Recovery, the eZ8 CPU responds to the interrupt request by fetching the corresponding interrupt vector and executing code from the vector address. To clear the WDT interrupt, clear the WDT bit in the Reset Status Register.

12.1.2.3. WDT Reset in Normal Operation

The WDT forces the device into the Reset state if it is configured to generate a System Reset when a time-out occurs; the WDT status bit is set to 1 (for details, see the [Reset Status Register \(RSTSTAT\)](#) on page 48). For more information about System Reset and the WDT status bit, see the [Reset, Stop-Mode Recovery and Low-Voltage Detection](#) chapter on page 38. Following a System Reset, the WDT Counter is initialized with its reset value.

12.1.2.4. WDT Reset in Stop Mode

If enabled in Stop Mode and configured to generate a System Reset when a time-out occurs and the device is in Stop Mode, the WDT initiates a Stop-Mode Recovery. Both the WDT status bit and the STOP bit in the [Reset Status Register \(RSTSTAT\)](#) (see page 48) are set to 1 following a WDT time-out in Stop Mode. For more information, see the [Reset, Stop-Mode Recovery and Low-Voltage Detection](#) section on page 38.

12.1.3. Watchdog Timer Reload Unlock Sequence

Writing the unlock sequence to the Watchdog Timer Reload High (WDTH) Register address unlocks the two Watchdog Timer Reload registers (WDTH and WDTL) to allow changes to the time-out period. These write operations to the WDTH Register address produce no effect on the bits in the WDTH Register. The locking mechanism prevents unwarranted writes to the Reload registers. The following sequence is required to unlock the Watchdog Timer Reload registers (WDTH and WDTL) for write access.

1. Write 55h to the Watchdog Timer Reload High Register (WDTH).
2. Write AAh to the Watchdog Timer Reload High Register (WDTH).
3. Write the appropriate value to the Watchdog Timer Reload High Register (WDTH).
4. Write the appropriate value to the Watchdog Timer Reload Low Register (WDTL).
When this write occurs, the Watchdog Timer Reload registers are again locked.

All steps of the WDT Reload Unlock sequence must be written in the order defined above. The values in these WDT Reload registers are loaded into the counter every time a WDT instruction is executed.

12.2. Watchdog Timer Register Definitions

The two Watchdog Timer Reload registers (WDTH and WDTL) are described in the following tables.

12.2.1. Watchdog Timer Reload High and Low Byte Registers

The Watchdog Timer Reload High and Low Byte (WDTH, WDTL) registers, shown in Tables 104 and 105, form the 16-bit reload value that is loaded into the Watchdog Timer when a WDT instruction executes; this 16-bit reload value is {WDTH[7:0], WDTL[7:0]}. Writing to these registers following the unlock sequence sets the appropriate reload value. Reading from these registers returns the current WDT count value.

Table 104. Watchdog Timer Reload High Byte Register (WDTH=FF2h)

Bit	7	6	5	4	3	2	1	0
Field	WDTH							
Reset	0	0	0	0	0	1	0	0
R/W	R/W	R/W	R/W	R/W	R/W	R/W	R/W	R/W
Address	FF2h							

Table 105. Watchdog Timer Reload Low Byte Register (WDTL=FF3h)

Bit	7	6	5	4	3	2	1	0
Field	WDTL							
Reset	0	0	0	0	0	0	0	0
R/W	R/W	R/W	R/W	R/W	R/W	R/W	R/W	R/W
Address	FF3h							

Bit	Description
[7:0]	Watchdog Timer Reload High and Low Bytes
WDTH,	WDTH: The WDT Reload High Byte is the most significant byte, or bits [15:8] of the 16-bit WDT reload value.
WDTL	WDTL: The WDT Reload Low Byte is the least significant byte, or bits [7:0] of the 16-bit WDT reload value.

Chapter 13. Real-Time Clock

The Real-Time Clock (RTC) provides both Calendar Mode and Counter Mode operation. In Calendar Mode, the Real-Time Clock maintains time by keeping count of seconds, minutes, hours, day-of-the-week, day-of-the-month, month and year. In Counter Mode, the RTC can be used as a general-purpose 32-bit timer. Features of the Real-Time Clock include:

- Selectable Calendar Mode or Counter Mode
- Four selectable clock sources
- Clock prescaler with optional automatic prescaler configuration for clock sources at 32.768kHz, 60Hz, and 50Hz

13.3. Architecture

A simplified block diagram of the RTC is shown in Figure 26.

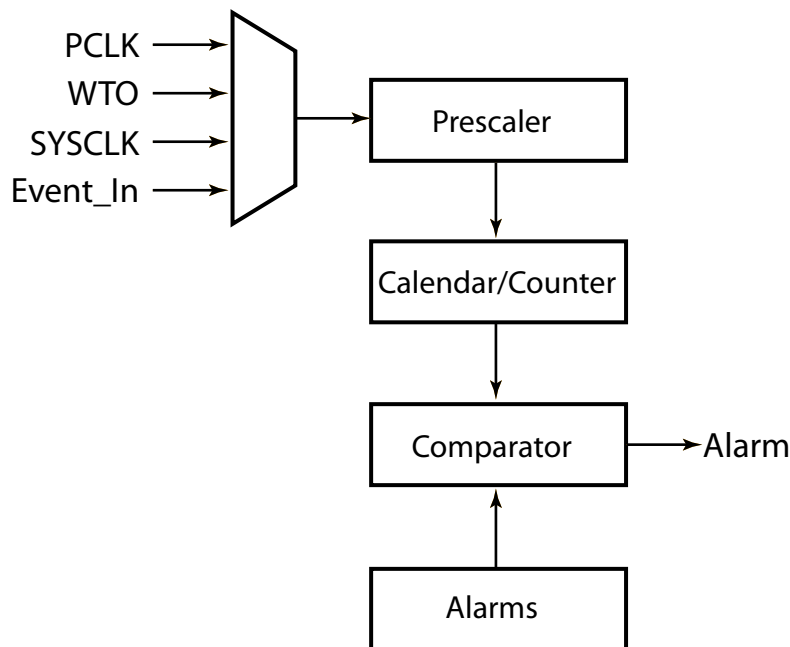

Figure 26. Real-Time Clock Block Diagram

13.4. Operation

13.4.1. Calendar Mode Operation

In Calendar Mode (MODE=0), The Real-Time Clock maintains time by keeping count of seconds, minutes, hours, day-of-the-week, day-of-the-month, month and year. The current time is kept in a 24-hour format. The format for all count and alarm registers is selectable between binary and binary-coded decimal (BCD) operations. The calendar operation maintains the correct day-of-the-month. Compensation for leap year must be performed by software.

13.4.2. Counter Mode Operation

In Counter Mode (MODE=1), four of the RTC counter registers are cascaded to form a 32-bit counter. An alarm can be configured by loading the RTC alarm registers with the appropriate alarm values and by selecting which counter bytes are enabled for matching in the RTC Alarm Control Register. The counter registers that are utilized in Counter Mode are: RTC_SEC (Byte 3, MSB), RTC_MIN (Byte 2), RTC_HRS (Byte 1), and RTC_DOM (Byte 0, LSB). The corresponding alarm registers that are utilized in Counter Mode are: RTC_ASEC (Byte 3, MSB), RTC_AMIN (Byte 2), RTC_AHRS (Byte 1), and RTC_ADOM (Byte 0, LSB).

13.4.3. Real-Time Clock Alarm

The clock is programmed to generate an alarm condition when the current count matches the alarm set-point registers. In Calendar Mode (MODE=0), alarm registers are available for seconds, minutes, hours, day-of-the-week, and day-of-the-month. In Counter Mode (MODE=1), alarms are available for each of the 4 bytes that comprise the 32-bit counter. Each alarm is independently enabled. To generate an alarm condition, the current time must match all enabled alarm values. For example, if the day-of-the-week and hour alarms are both enabled, the alarm only occurs at a specified hour on a specified day. The alarm triggers an interrupt if configured to do so in the Interrupt Controller. The alarm status, ALARM, is set if the alarm condition is currently met.

Alarm value registers and alarm control registers are written at any time. Alarm conditions are generated when the count value matches the alarm value. The comparison of alarm and count values occurs whenever the RTC count increments. With automatically configured prescaling (FREQ_SEL) of 32,768kHz, 50Hz, or 60Hz, the RTC count increments one time every second. The RTC is also forced to perform a comparison at any time by writing a 1 to the RTC_LOCK bit (the RTC_LOCK bit is not required to be changed to a 0 first).

13.4.4. Real-Time Clock Source Selection

The RTC can be driven by four possible clock sources:

PCLK (CLK_SEL=00). Selecting the 32.768kHz clock source (FREQ_SEL=00) automatically configures the clock prescaler for this frequency.

WTO (CLK_SEL=01). When WTO is selected, the RTC is typically run in Counter Mode (MODE=1) with selectable clock prescaler setting (FREQ_SEL=11).

SYSCLK (CLK_SEL=10). When SYSCLK is selected, the RTC is typically run in Counter Mode (MODE=1) with selectable clock prescaler setting (FREQ_SEL=11).

Event In (CLK_SEL=11). The Event System can be configured to connect Event In to a GPIO that serves as a 50Hz or 60Hz power-line clock source via an Event System channel. Automatic configuration of the clock prescaler for a power-line clock source is provided via FREQ_SEL= 01 or 10.

The clock source and clock frequencies are selected in the RTCTIM Register. This register is read/write when the RTC is unlocked (RTC_LOCK=0) and read-only when the RTC is locked (RTC_LOCK=1).

13.4.5. Synchronous Reading of the Real Time Clock Counts

With an automatically-configured prescaling (FREQ_SEL) of 32,768kHz, 50Hz, or 60Hz, the RTC count increments one time every second. To read counts while the RTC is enabled (RTC_LOCK=1), the sync bit should be consulted. If SYNC=0, counts are static and safe to read. If SYNC=1, counts may not be static.

When the prescaler is configured directly (FREQ_SEL=11) and the RTC is enabled (RTC_LOCK=1), the sync bit is set (SYNC=1). In this case, to validate the reading of counts, a second read should be compared with the initial read.

When the RTC is disabled (RTC_LOCK=0) and counting has ceased, the sync bit is reset (SYNC=0).

13.4.6. Real-Time Clock Recommended Operation

Following a Power-On Reset (POR), the counter values of the RTC are undefined and all alarms are disabled. Zilog recommends initializing the Real-Time Clock:

- Write to RTC_CTRL to clear RTC_LOCK to disable the RTC counter; while unlocked, the clock prescaler is reset
- Write values to the Real Time Clock Timing Register (RTC_TIM) to select clock source and frequency
- Write values to the RTC count registers to set the current time
- Write values to the RTC alarm registers to set the appropriate alarm conditions
- Write to RTC_CTRL to set RTC_LOCK; setting RTC_LOCK enables the clock prescaler

13.4.7. Real-Time Clock Enable and Count Register Writing

The RTC_LOCK control bit controls enabling RTC counting as well as write access to the RTC count registers and the RTC Timing Register (RTC_TIM). When unlocked

(RTC_LOCK=0), RTC counting is disabled and the count registers and the RTC Timing Register are read/write. When locked (RTC_LOCK=1), RTC counting is enabled and the count registers and RTC Timing Register are read-only. The default at Power-On Reset is for the RTC to be unlocked.

13.5. Real-Time Clock Control Register Definitions

The Real-Time Clock control registers are defined in this section.

13.5.1. Real-Time Clock Seconds Register

This register contains the current seconds count. The value in the RTC_SEC Register, shown in Table 106, is unchanged by a Power-On Reset (POR). The current setting of BCD_EN determines whether the values in this register are binary (BCD_EN=0) or binary-coded decimal (BCD_EN=1). Access to this register is read-only if the RTC is locked, and read/write if the RTC is unlocked.

Table 106. Real-Time Clock Seconds Register (RTC_SEC)

Bit	7	6	5	4	3	2	1	0
Field when BCD_EN=1, MODE=0	Reserved	TEN_SEC			SEC			
Field when BCD_EN=0, MODE=0	Reserved		SEC					
Field when BCD_EN=X, MODE=1	SEC							
Power-On Reset	X	X	X	X	X	X	X	X
CPU Access	R/W	R/W	R/W	R/W	R/W	R/W	R/W	R/W
Address	F30h							

Note: *X=undefined; R/W=read-only if RTC is locked, read/write if RTC is unlocked.

Bit	Description
Binary-Coded Decimal Operation (BCD_EN=1, MODE=0)	
[7]	Reserved 0: This bit is reserved and must be programmed to 0.
[6:4] TEN_SEC	Current Seconds Tens Values 0–5 represent the tens digit of the current seconds count.
[3:0] SEC	Current Seconds Ones Values 0–9 represent the ones digit of the current seconds count.

Bit	Description (Continued)
Binary Operation (BCD_EN=0, MODE=0)	
[7:6]	Reserved These bits are reserved and must be programmed to 00.
[5:0] SEC	Current Seconds Values 00h–3Bh represent the current seconds count.
Counter Mode Operation (BCD_EN=X, MODE=1)	
[7:0] SEC	Seconds Count Values 00h–FFh represent Counter byte 3 (MSB).

13.5.2. Real-Time Clock Minutes Register

This register contains the current minutes count. The value in the RTC_MIN Register, shown in Table 107, is unchanged by a Power-On Reset (POR). The current setting of BCD_EN determines whether the values in this register are binary (BCD_EN=0) or binary-coded decimal (BCD_EN=1). Access to this register is read-only if the RTC is locked, and read/write if the RTC is unlocked.

Table 107. Real-Time Clock Minutes Register (RTC_MIN)

Bit	7	6	5	4	3	2	1	0
Field when BCD_EN=1, MODE=0	Reserved	TEN_MIN			MIN			
Field when BCD_EN=0, MODE=0	Reserved		MIN					
Field when BCD_EN=X, MODE=1	MIN							
Power-On Reset	X	X	X	X	X	X	X	X
CPU Access	R/W	R/W	R/W	R/W	R/W	R/W	R/W	R/W
Address	F31h							

Note: X=undefined; R/W = read-only if RTC locked, read/write if RTC unlocked.

Bit	Description
Binary-Coded Decimal Operation (BCD_EN=1, MODE=0)	
[7]	Reserved This bit is reserved and must be programmed to 0.
[6:4] TEN_MIN	Current Minutes Tens Values 0–5 represent the tens digit of the current minutes count.

Bit	Description (Continued)
Binary-Coded Decimal Operation (BCD_EN=1, MODE=0) (Continued)	
[3:0] MIN	Current Minutes Ones Values 0–9 represent the ones digit of the current minutes count.
Binary Operation (BCD_EN=0, MODE=0)	
[7:6]	Reserved These bits are reserved and must be programmed to 00.
[5:0] MIN	Current Minutes Values 00h–3Bh represent the current minutes count.
Counter Mode Operation (BCD_EN=X, MODE=1)	
[7:0] MIN	Minutes Count Values 00h–FFh represent Counter byte 2.

13.5.3. Real-Time Clock Hours Register

This register contains the current hours count. The value in the RTC_HRS Register, shown in Table 108, is unchanged by a Power-On Reset (POR). The current setting of BCD_EN determines whether the values in this register are binary (BCD_EN=0) or binary-coded decimal (BCD_EN=1). Access to this register is read-only if the RTC is locked, and read/write if the RTC is unlocked.

Table 108. Real-Time Clock Hours Register (RTC_HRS)

Bit	7	6	5	4	3	2	1	0
Field when BCD_EN=1, MODE=0	Reserved		TEN_HRS		HRS			
Field when BCD_EN=0, MODE=0	Reserved			HRS				
Field when BCD_EN=X, MODE=1	HRS							
Power-On Reset	X	X	X	X	X	X	X	X
CPU Access	R/W	R/W	R/W	R/W	R/W	R/W	R/W	R/W
Address	F32h							

Note: X=undefined; R/W =read-only if RTC locked, read/write if RTC unlocked.

Bit	Description
Binary-Coded Decimal Operation (BCD_EN=1, MODE=0)	
[7:6]	Reserved These bits are reserved and must be programmed to 00.
[5:4] TEN_HRS	Current Hours Tens Values 0–2 represent the tens digit of the current hours count.
[3:0] HRS	Current Hours Ones Values 0–9 represent the ones digit of the current hours count.
Binary Operation (BCD_EN=0, MODE=0)	
[7:5]	Reserved These bits are reserved and must be programmed to 000.
[4:0] HRS	Current Hours Values 00h–17h represent the current hours count.
Counter Mode Operation (BCD_EN=X, MODE=1)	
[7:0] HRS	Hours Count Values 00h–FFh represent Counter byte 1.

13.5.4. Real-Time Clock Day-of-the-Month Register

This register contains the current day-of-the-month count. The RTC_DOM Register, shown in Table 109, begins counting at 01h. The value in the RTC_DOM Register is unchanged by a Power-On Reset (POR). The current setting of BCD_EN determines whether the values in this register are binary (BCD_EN=0) or binary-coded decimal (BCD_EN=1). Access to this register is read-only if the RTC is locked, and read/write if the RTC is unlocked.

Table 109. Real-Time Clock Day-of-the-Month Register (RTC_DOM)

Bit	7	6	5	4	3	2	1	0
Field when BCD_EN=1, MODE=0	Reserved		TENS_DOM		DOM			
Field when BCD_EN=0, MODE=0	Reserved			DOM				
Field when BCD_EN=X, MODE=1	DOM							
Power-On Reset	0	0	X	X	X	X	X	X
CPU Access	R/W	R/W	R/W	R/W	R/W	R/W	R/W	R/W
Address	F33h							

Note: X = undefined; R/W = read-only if RTC locked, read/write if RTC unlocked.

Bit	Description
Binary-Coded Decimal Operation (BCD_EN=1, MODE=0)	
[7:6]	Reserved These bits are reserved and must be programmed to 00.
[5:4] TENS_DOM	Current Day Of The Month Tens Values 0–3 represent the tens digit of the current day-of-the-month count.
[3:0] DOM	Current Day Of The Month Ones Values 0–9 represent the ones digit of the current day-of-the-month count.
Binary Operation (BCD_EN=0, MODE=0)	
[7:5]	Reserved These bits are reserved and must be programmed to 000.
[4:0] DOM	Day Of The Month Count Values 01h–1Fh represent the current day-of-the-month count.
Counter Mode Operation (BCD_EN=X, MODE=1)	
[7:0] DOM	Day Of The Month Count Values 00h–FFh represent Counter byte 0 (LSB).



13.5.5. Real-Time Clock Day-of-the-Week Register

This register contains the current day-of-the-week count. The RTC_DOW Register, shown in Table 110, begins counting at 01h. The value in this register is unchanged by a Power-On Reset (POR). The current setting of BCD_EN determines whether the value in this register is binary (BCD_EN=0) or binary-coded decimal (BCD_EN=1). Access to this register is read-only if the RTC is locked, and read/write if the RTC is unlocked.

Table 110. Real-Time Clock Day-of-the-Week Register (RTC_DOW)

Bit	7	6	5	4	3	2	1	0
Field when BCD_EN=1, MODE=0	Reserved					DOW		
Field when BCD_EN=0, MODE=0	Reserved					DOW		
Power-On Reset	X	X	X	X	X	X	X	X
CPU Access	R	R	R	R	R	R/W	R/W	R/W
Address	F34h							

Note: X = undefined; R = read-only; R/W = read-only if RTC locked, read/write if RTC unlocked.

Bit	Description
Binary-Coded Decimal Operation (BCD_EN=1, MODE=0)	
[7:3]	Reserved These bits are reserved and must be programmed to 00000.
[2:0] DOW	Current Day Of The Week Values 1–7 represent the current day-of-the-week count.
Binary Operation (BCD_EN=0, MODE=0)	
[7:3]	Reserved These bits are reserved and must be programmed to 00000.
[2:0] DOW	Current Day Of The Week Values 01h–07h represent the current day-of-the-week count.

13.5.6. Real-Time Clock Month Register

This register contains the current month count. The RTC_MON Register, shown in Table 111, begins counting at 01h. The value in the RTC_MON Register is unchanged by a Power-On Reset (POR). The current setting of BCD_EN determines whether the values in this register are binary (BCD_EN=0) or binary-coded decimal (BCD_EN=1). Access to this register is read-only if the RTC is locked, and read/write if the RTC is unlocked.

Table 111. Real-Time Clock Month Register (RTC_MON)

Bit	7	6	5	4	3	2	1	0
Field when BCD_EN=1	Reserved			TENS_MON	MON			
Field when BCD_EN=0	Reserved			MON				
Power-On Reset	0	0	0	X	X	X	X	X
CPU Access	R	R	R	R/W	R/W	R/W	R/W	R/W
Address	F35h							

Note: X = undefined; R/W = read-only if RTC locked, read/write if RTC unlocked.

Bit	Description
Binary-Coded Decimal Operation (BCD_EN=1)	
[7:5]	Reserved These bits are reserved and must be programmed to 000.
[4] TENS_MON	Current Month Tens Values 0–1 represent the tens digit of the current month count.
[3:0] MON	Current Month Ones Values 0–9 represent the ones digit of the current month count.
Binary Operation (BCD_EN=0)	
[7:4]	Reserved These bits is reserved and must be programmed to 0000.
[3:0] MON	Current Month Count Values 1h–Ch represent the current month count.

13.5.7. Real-Time Clock Year Register

This register contains the current year count. The value in the RTC_YR Register, shown in Table 112, is unchanged by a Power-On Reset (POR). The current setting of BCD_EN determines whether the values in this register are binary (BCD_EN=0) or binary-coded decimal (BCD_EN=1). Access to this register is read-only if the RTC is locked, and read/write if the RTC is unlocked.

Table 112. Real-Time Clock Year Register (RTC_YR)

Bit	7	6	5	4	3	2	1	0
Field when BCD_EN=1	TENS_YR				YR			
Field when BCD_EN=0	Reserved	YR						
Power-On Reset	X	X	X	X	X	X	X	X
CPU Access	R/W	R/W	R/W	R/W	R/W	R/W	R/W	R/W
Address	F36h							

Note: X = undefined; R/W = read-only if RTC locked, read/write if RTC unlocked.

Bit	Description
Binary-Coded Decimal Operation (BCD_EN=1)	
[7:4] TENS_YR	Current Year Tens Values 0–9 represent the tens digit of the current year count.
[3:0] YR	Current Year Ones Values 0–9 represent the ones digit of the current year count.
Binary Operation (BCD_EN=0)	
[7]	Reserved This bit is reserved and must be programmed to 0.
[6:0] YR	Current Year Count Values 00h–63h represent the current year count.

13.5.8. Real-Time Clock Alarm Seconds Register

This register contains the alarm seconds value. The value in the RTC_ASEC Register, shown in Table 113, is unchanged by a Power-On Reset (POR). The current setting of BCD_EN determines whether the values in this register are binary (BCD_EN=0) or binary-coded decimal (BCD_EN=1).

Table 113. Real-Time Clock Alarm Seconds Register (RTC_ASEC)

Bit	7	6	5	4	3	2	1	0
Field when BCD_EN=1, MODE = 0	Reserved	ATEN_SEC			ASEC			
Field when BCD_EN=0, MODE = 0	Reserved		ASEC					
Field when BCD_EN=X, MODE=1	ASEC							
Power-On Reset	X	X	X	X	X	X	X	X
CPU Access	R/W	R/W	R/W	R/W	R/W	R/W	R/W	R/W
Address	F37h							

Note: X=undefined; R/W=read/write.

Bit	Description
Binary-Coded Decimal Operation (BCD_EN=1, MODE=0)	
[7]	Reserved This bit is reserved and must be programmed to 0.
[6:4] ATEN_SEC	Alarm Seconds Tens Values 0–5 represent the tens digit of the alarm seconds value.
[3:0] ASEC	Alarm Seconds Ones Values 0–9 represent the ones digit of the alarm seconds value.
Binary Operation (BCD_EN=0, MODE=0)	
[7:6]	Reserved These bits are reserved and must be programmed to 00.
[5:0] ASEC	Alarm Seconds Values 00h–3Bh represent the alarm seconds value.
Counter Mode Operation (BCD_EN=X, MODE=1)	
[7:0] ASEC	Alarm Seconds Count Values 00h–FFh represent the most-significant byte of Counter Mode Alarm, Byte 3.

13.5.9. Real-Time Clock Alarm Minutes Register

This register contains the alarm minutes value. The value in the RTC_AMIN Register, shown in Table 114, is unchanged by a Power-On Reset (POR). The current setting of BCD_EN determines whether the values in this register are binary (BCD_EN=0) or binary-coded decimal (BCD_EN=1).

Table 114. Real-Time Clock Alarm Minutes Register (RTC_AMIN)

Bit	7	6	5	4	3	2	1	0
Field when BCD_EN=1, MODE = 0	Reserved	ATEN_MIN			ATEN_MIN			
Field when BCD_EN=0, MODE = 0	Reserved		ATEN					
Field when BCD_EN=X, MODE=1	ATEN							
Power-On Reset	X	X	X	X	X	X	X	X
CPU Access	R/W	R/W	R/W	R/W	R/W	R/W	R/W	R/W
Address	F38h							

Note: X=undefined; R/W=read/write.

Bit	Description
Binary-Coded Decimal Operation (BCD_EN=1, MODE=0)	
[7]	Reserved This bit is reserved and must be programmed to 0.
[6:4] ATEN_MIN	Alarm Minutes Tens Values 0–5 represent the tens digit of the alarm minutes value.
[3:0] AMIN	Alarm Minutes Ones Values 0–9 represent the ones digit of the alarm minutes value.
Binary Operation (BCD_EN=0, MODE=0)	
[7:6]	Reserved These bits are reserved and must be programmed to 00.
[5:0] AMIN	Alarm Minutes Values 00h–3Bh represent the alarm minutes value.
Counter Mode Operation (BCD_EN=X, MODE=1)	
[7:0] AMIN	Alarm Minutes Count Values 00h–FFh represent Counter Mode Alarm Byte 2.



13.5.10. Real-Time Clock Alarm Hours Register

This register contains the alarm hours value. The value in the RTC_AHRS Register, shown in Table 115, is unchanged by a Power-On Reset (POR). The current setting of BCD_EN determines whether the values in this register are binary (BCD_EN=0) or binary-coded decimal (BCD_EN=1).

Table 115. Real-Time Clock Alarm Hours Register (RTC_AHRS)

Bit	7	6	5	4	3	2	1	0
Field when BCD_EN=1, MODE = 0	Reserved		ATEN_HRS		AHRS			
Field when BCD_EN=0, MODE = 0	Reserved			AHRS				
Field when BCD_EN=X, MODE=1	AHRS							
Power-On Reset	X	X	X	X	X	X	X	X
CPU Access	R/W	R/W	R/W	R/W	R/W	R/W	R/W	R/W
Address	F39h							

Note: X=undefined; R/W=read/write.

Bit	Description
Binary-Coded Decimal Operation (BCD_EN=1, MODE=0)	
[7:6]	Reserved These bits are reserved and must be programmed to 00.
[5:4] ATEN_HRS	Alarm Hours Tens Values 0–2 represent the tens digit of the alarm hours value.
[3:0] AHRS	Alarm Hours Ones Values 0–9 represent the ones digit of the alarm hours value.
Binary Operation (BCD_EN=0, MODE=0)	
[7:5]	Reserved These bits are reserved and must be programmed to 000.
[4:0] AHRS	Alarm Hours Values 00h–17h represent the alarm hours value.
Counter Mode Operation (BCD_EN=X, MODE=1)	
[7:0] AHRS	Alarm Hours Count Values 00h–FFh represent Counter Mode Alarm Byte 1.

13.5.11. Real-Time Clock Alarm Day-of-the-Month Register

This register contains the alarm date value. The value in the RTC_ADOM Register, shown in Table 116, is unchanged by a Power-On Reset (POR). The current setting of BCD_EN determines whether the value in this register is binary (BCD_EN=0) or binary-coded decimal (BCD_EN=1).

Table 116. Real-Time Clock Alarm Day-of-the-Month Register (RTC_ADOM)

Bit	7	6	5	4	3	2	1	0
Field when BCD_EN=1, MODE=0	Reserved		ATEN_DOM		ADOM			
Field when BCD_EN=0, MODE=0	Reserved			ADOM				
Field when BCD_EN=X, MODE=1	ADOM							
Power-On Reset	0	0	X	X	X	X	X	X
CPU Access	R/W	R/W	R/W	R/W	R/W	R/W	R/W	R/W
Address	F3Ah							

Note: X=undefined; R=read-only; R/W=read/write.

Bit	Description
Binary-Coded Decimal Operation (BCD_EN=1, MODE=0)	
[7:6]	Reserved These bits are reserved and must be programmed to 00.
[5:4] ATEN_DOM	Alarm Day Of The Month Tens Values 0–3 represent the tens digit of the alarm day-of-the-month value.
[3:0] ADOM	Alarm Day Of The Month Ones Values 0–9 represent the ones digit of the alarm day-of-the-month value.
Binary Operation (BCD_EN=0, MODE=0)	
[7:5]	Reserved These bits are reserved and must be programmed to 000.
[4:0] ADOM	Alarm Day Of The Month Date Values 00h–1Eh represent the alarm date.
Counter Mode Operation (BCD_EN=X, MODE=1)	
[7:0] ADOM	Alarm Day Of The Month Count Values 00h–FFh represent the least-significant byte of Counter Mode Alarm, Byte 0.

13.5.12. Real-Time Clock Alarm Day-of-the-Week Register

The RTC_ADOW Register, shown in Table 117, contains the alarm day-of-the-week value. The value in this is unchanged by a Power-On Reset (POR). The current setting of BCD_EN determines whether the value in this register is binary (BCD_EN=0) or binary-coded decimal (BCD_EN=1).

Table 117. Real-Time Clock Alarm Day-of-the-Week Register (RTC_ADOW)

Bit	7	6	5	4	3	2	1	0
Field when BCD_EN=1	Reserved					ADOW		
Field when BCD_EN=0	Reserved					ADOW		
Power-On Reset	X	X	X	X	X	X	X	X
CPU Access	R/	R	R	R	R	R/W	R/W	R/W
Address	F3Bh							

Note: X=undefined; R=read-only; R/W=read/write.

Bit	Description
Binary-Coded Decimal Operation (BCD_EN=1)	
[7:3]	Reserved These bits are reserved and must be programmed to 00000.
[2:0] ADOW	Alarm Day Of The Week Values 1–7 represent the alarm day-of-the-week value.
Binary Operation (BCD_EN=0)	
[7:3]	Reserved These bits are reserved and must be programmed to 00000.
[2:0] ADOW	Alarm Day Of The Week Values 01h–07h represent the alarm day-of-the-week.

13.5.13. Real-Time Clock Alarm Control Register

The RTC_ACTRL Register, shown in Table 118, contains control bits for the Real-Time Clock. This register is cleared by a Power-On Reset (POR).

Table 118. Real-Time Clock Alarm Control Register (RTC_ACTRL)

Bit	7	6	5	4	3	2	1	0
Field when MODE=0	Reserved			ADOM_ EN	ADOW_ EN	AHRS_ EN	AMIN_ EN	ASEC_ EN
Field when MODE=1	Reserved			ADOM_ EN	Reserved	AHRS_ EN	AMIN_ EN	ASEC_ EN
Power-On Reset	0	0	0	0	0	0	0	0
CPU Access	R	R	R	R/W	R/W	R/W	R/W	R/W
Address	F3Ch							

Note: X=undefined; R=read-only; R/W=read/write

Bit	Description
Calendar Mode Operation (MODE=0)	
[7:5]	Reserved These bits are reserved and must be programmed to 000.
[4] ADOM_EN	Alarm Day Of The Month Enable 0: The day-of-the-month alarm is disabled. 1: The day-of-the-month alarm is enabled.
[3] ADOW_EN	Alarm Day Of The Week Enable 0: The day-of-the-week alarm is disabled. 1: The day-of-the-week alarm is enabled.
[2] AHRS_EN	Alarm Hours Enable 0: The hours alarm is disabled. 1: The hours alarm is enabled.
[1] AMIN_EN	Alarm Minutes Enable 0: The minutes alarm is disabled. 1: The minutes alarm is enabled.
[0] ASEC_EN	Alarm Seconds Enable 0: The seconds alarm is disabled. 1: The seconds alarm is enabled.

Bit	Description (Continued)
Counter Mode Operation (MODE=1)	
[7:5]	Reserved These bits are reserved and must be programmed to 000.
[4] ADOM_EN	Byte 0 Alarm Day Of Month Enable 0: The Byte0 alarm is disabled. 1: The Byte0 alarm is enabled.
[3]	Reserved This bit is reserved and must be programmed to 0.
[2] AHRS_EN	Byte 1 Alarm Hours Enable 0: The Byte1 alarm is disabled. 1: The Byte1 alarm is enabled.
[1] AMIN_EN	Byte 2 Alarm Minutes Enable 0: The Byte2 alarm is disabled. 1: The Byte2 alarm is enabled.
[0] ASEC_EN	Byte 3 Alarm Seconds Enable 0: The Byte3 alarm is disabled. 1: The Byte3 alarm is enabled.

13.5.14. Real-Time Clock Timing Register

The RTC_TIM Register, shown in Table 119, contains timing control for the Real-Time Clock. This register is cleared by a Power-On Reset (POR). Access to this register is read-only if the RTC is locked and read/write if the RTC is unlocked.

The CLK_SEL bits select the RTC clock source. Note that the clock source is enabled separately; see the [Clock System](#) chapter on page 96 to learn more. If the 32.768 kHz clock frequency option is selected (CLK_FRQ=00), the internal prescaler is set to divide by 32768. If the power-line frequency option is selected, the prescale value is set according to the selected frequency.

Table 119. Real-Time Clock Timing Register (RTC_TIM)

Bit	7	6	5	4	3	2	1	0
Field	Reserved	PRESCALE			FREQ_SEL		CLK_SEL	
Power-On Reset	0	0	0	0	0	0	0	0
CPU Access	R	R/W	R/W	R/W	R/W	R/W	R/W	R/W
Address	F3Eh							

Note: X=undefined; R=read-only; R/W=read/write.

Bit	Description
[7]	Reserved This bit is reserved and must be programmed to 0.
[6:4] PRESCALE	RTC Prescale PRESCALE is utilized only if FREQ_SEL=11. 000: Prescale by 1. 0. 001: Prescale by 2. 010: Prescale by 4. 011: Prescale by 8. 100: Prescale by 16. 101: Prescale by 32. 110: Prescale by 64. 111: Prescale by 128.
[3:2] FREQ_SEL	RTC Frequency Select 00: 32.768kHz. The prescaler is automatically configured for this frequency. 01: 60Hz power-line frequency. The prescaler is automatically configured for this frequency. 10: 50Hz power-line frequency. The prescaler is automatically configured for this frequency. 11: Use PRESCALE[2:0].
[1:0] CLK_SEL	RTC Source Select 00: PCLK (32.768kHz). 01: WTO. 10: SYSCLK. 11: Event System input. The Event System is typically configured to provide a 50Hz or 60Hz clock from a GPIO.

13.5.15. Real-Time Clock Control Register

The RTC_CTRL Register, shown in Table 120, contains control and status bits for the Real-Time Clock. This register is cleared by a Power-On Reset (POR). The ALARM bit is updated by setting (locking) the RTC_LOCK bit or by an increment of the RTC count. Setting the BCD_EN bit causes the RTC to use binary-coded decimal (BCD) counting in all registers including the alarm set points.

Table 120. Real-Time Clock Control Register (RTC_CTRL)

Bit	7	6	5	4	3	2	1	0
Field	SYNC	ALARM	Reserved	BCD_EN	MODE	Reserved	DAY_SAV	RTC_LOCK
Power-On Reset	0	0	0	0	0	0	0	0
CPU Access	R	R	R/W	R/W	R/W	R/W	R/W	R/W
Address	F3Fh							

Note: X=undefined; R=read-only; R/W=read/write.

Bit	Description
[7] SYNC	RTC Synchronize 0: Counts are static and safe to read. 1: Counts may not be static. To validate the reading of counts, a second read should be compared with the initial read.
[6] ALARM	RTC Alarm 0: Alarm is inactive. 1: Alarm is active.
[5]	Reserved This bit is reserved and must be programmed to 0.
[4] BCD_EN	Binary Coded Decimal Enable 0: RTC count and alarm value registers are binary. 1: RTC count and alarm value registers are BCD. Ignored if Counter Mode is selected
[3] MODE	RTC Mode 0: Calendar Mode. 1: Counter Mode
[2]	Reserved This bit is reserved and must be programmed to 0.
[1] DAY_SAV	Daylight Savings Time This register bit has been allocated as a storage location only for software applications that use DST. No action is performed by the RTC when setting or clearing this bit. 0: Suggested value for Daylight Savings Time not selected. 1: Suggested value for Daylight Savings Time selected.
[0] RTC_LOCK	RTC Count Lock 0: RTC count registers are unlocked to allow write access. RTC counter is disabled and the clock prescaler is cleared. 1: RTC count registers are locked to prevent write access. RTC counter is enabled. When enabled, the RTC runs in all operating modes, including Stop Mode.

Chapter 14. UART-LDD

The Local Interconnect Network Universal Asynchronous Receiver/Transmitter (UART-LDD) is a full-duplex communication channel capable of handling asynchronous data transfers in standard UART applications and providing LIN, DALI, and DMX protocol support. The UART-LDD is a superset of the standard F6482 Series MCU UART, providing all of its standard features, LIN/DALI/DMX protocol support and a digital noise filter.

UART-LDD includes the following features:

- 8-bit asynchronous data transfer
- Selectable even- and odd-parity generation and checking
- Option of 1 or 2 stop bits
- Selectable Multiprocessor (9-bit) Mode with three configurable interrupt schemes
- Separate transmit and receive interrupts
- Framing, parity, overrun and break detection
- 16-bit baud rate generator (BRG) which can function as a general-purpose timer with interrupt
- Driver Enable output for external bus transceivers
- LIN protocol support for both Master and Slave modes:
 - Break generation and detection
 - Selectable slave autobaud
 - Check Tx vs. Rx data when sending
- DALI protocol support for both Master and Slave modes:
 - Biphase data encoding
 - Slave address matching
- DMX protocol support for both Master and Slave modes:
 - Slave address matching
 - Automatic break generation
- Configuring a digital-noise filter on the Receive Data line
- DMA support

14.1. UART-LDD Architecture

The UART-LDD consists of three primary functional blocks: transmitter, receiver and baud-rate generator. The UART-LDD's transmitter and receiver function independently but use the same baud rate and data format. The basic UART operation is enhanced by the Noise Filter. Figure 27 shows the UART-LDD architecture.

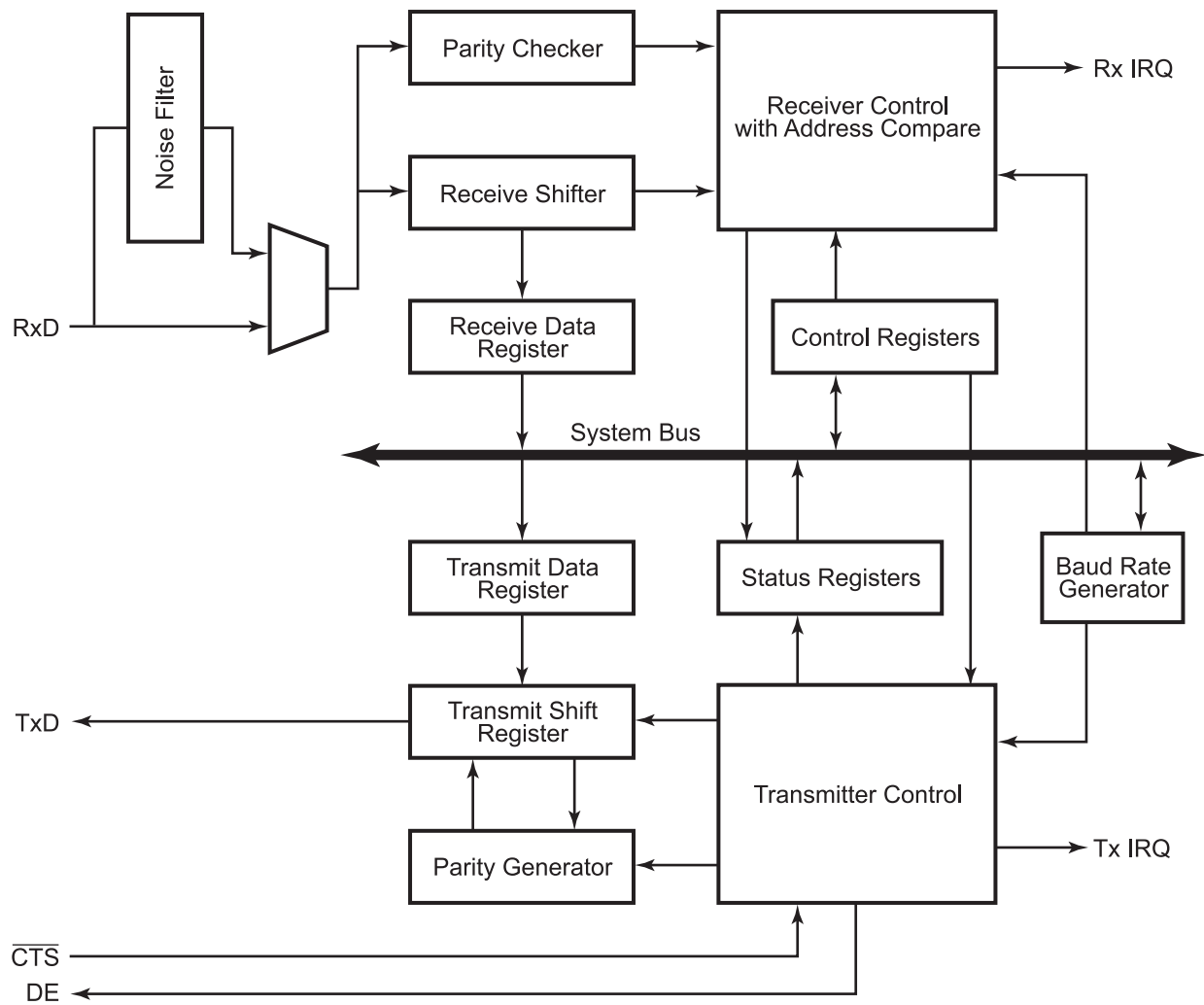

Figure 27. UART-LDD Block Diagram

14.1.1. Data Format for Standard UART Modes

The UART-LDD always transmits and receives data in an 8-bit data format with the least significant bit first. An even-or-odd parity bit or multiprocessor address/data bit can be optionally added to the data stream. Each character begins with an active Low start bit and ends with either one or two active High stop bits. Figures 28 and 29 show the asynchronous data format employed by the UART-LDD without parity and with parity, respectively.

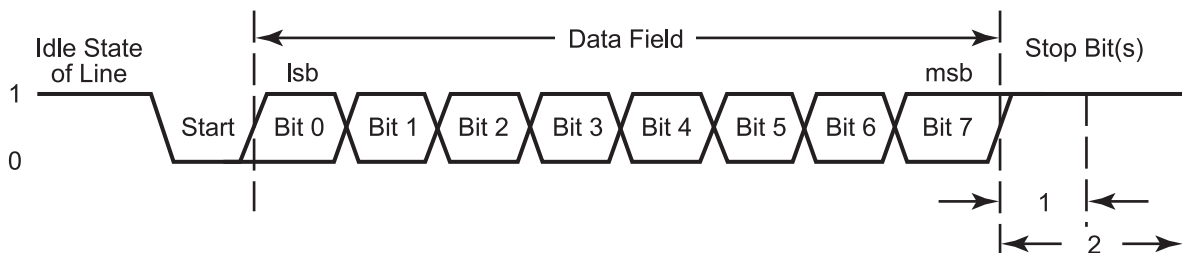

Figure 28. UART-LDD Asynchronous Data Format without Parity

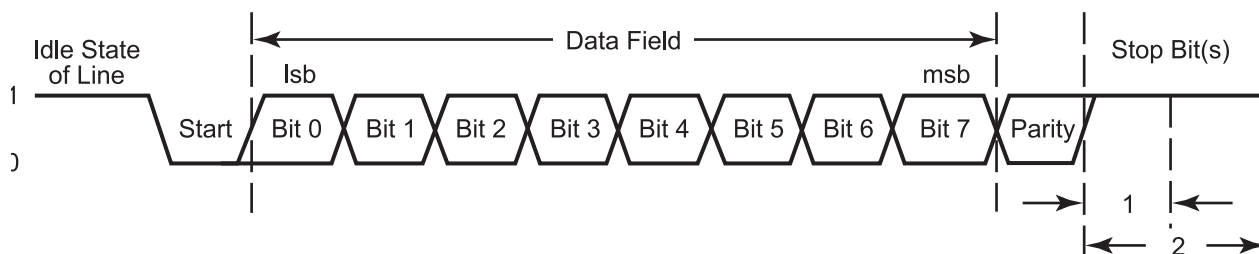

Figure 29. UART-LDD Asynchronous Data Format with Parity

14.1.2. Transmitting Data using the Polled Method

Observe the following steps to transmit data using the polled-operating method:

1. Write to the UART-LDD Baud Rate High and Low Byte registers to set the appropriate baud rate.
2. Enable the UART-LDD pin functions by configuring the associated GPIO port pins for alternate-function operation.
3. If Multiprocessor Mode is appropriate, write to the UART-LDD Control 1 Register to enable Multiprocessor (9-bit) Mode functions.
4. Set the Multiprocessor Mode Select (MPEN) bit to enable Multiprocessor Mode.

5. Write to the UART-LDD Control 0 Register to:
 - a. Set the Transmit Enable (TEN) bit to enable the UART-LDD for data transmission.
 - b. If parity is appropriate and Multiprocessor Mode is not enabled, set the parity enable (PEN) bit and select either even-or-odd parity (PSEL).
 - c. Set or clear the CTSE bit to enable or disable control from the remote receiver using the $\overline{\text{CTS}}$ pin.
6. Check the TDRE bit in the UART-LDD Status 0 Register to determine if the Transmit Data Register is empty (indicated by a 1); if empty, continue to [Step 7](#). If the Transmit Data Register is full (indicated by a 0), continue to monitor the TDRE bit until the Transmit Data Register becomes available to receive new data.
7. If operating in Multiprocessor Mode, write to the UART-LDD Control 1 Register to select the outgoing address bit.
 - Set the Multiprocessor Bit Transmitter (MPBT) if sending an address byte; clear it if sending a data byte.
8. Write the data byte to the UART-LDD Transmit Data Register. The transmitter automatically transfers the data to the Transmit Shift Register and transmits the data.
9. If appropriate – and if Multiprocessor Mode is enabled – changes can be made to the Multiprocessor Bit Transmitter (MPBT) value.
10. To transmit additional bytes, return to [Step 5](#).

14.1.3. Transmitting Data Using Interrupt-Driven Method

The UART-LDD Transmitter interrupt indicates the availability of the Transmit Data Register to accept new data for transmission. Observe the following steps to configure the UART-LDD for interrupt-driven data transmission:

1. Write to the UART-LDD Baud Rate High and Low Byte registers to set the appropriate baud rate.
2. Enable the UART-LDD pin functions by configuring the associated GPIO port pins for alternate function operation.
3. Execute a DI instruction to disable interrupts.
4. Write to the interrupt control registers to enable the UART-LDD Transmitter interrupt and set the appropriate priority.
5. If Multiprocessor Mode is appropriate, write to the UART-LDD Control 1 Register to enable Multiprocessor (9-bit) Mode functions.
6. Set the Multiprocessor Mode Select (MPEN) bit to enable Multiprocessor Mode.
7. Write to the UART-LDD Control 0 Register to:
 - a. Set the transmit enable (TEN) bit to enable the UART-LDD for data transmission.

- b. If Multiprocessor Mode is not enabled, then enable parity if appropriate and select either even or odd parity.
 - c. Set or clear the CTSE bit to enable or disable control from the remote receiver via the CTS pin.
8. Execute an EI instruction to enable interrupts.

The UART-LDD is now configured for interrupt-driven data transmission. Because the UART-LDD Transmit Data Register is empty, an interrupt is generated immediately. When the UART-LDD Transmit interrupt is detected and there is transmit data ready to send, the associated interrupt service routine (ISR) performs the following:

1. If in Multiprocessor Mode, writes to the UART-LDD Control 1 Register to select the outgoing address bit:
 - Sets the Multiprocessor Bit Transmitter (MPBT) if sending an address byte, clears it if sending a data byte.
2. Writes the data byte to the UART-LDD Transmit Data Register. The transmitter automatically transfers the data to the Transmit Shift Register and transmits the data.
3. Executes the IRET instruction to return from the interrupt-service routine and wait for the Transmit Data Register to again become empty.

If a transmit interrupt occurs and there is no transmit data ready to send, the interrupt service routine executes the IRET instruction. When the application does have data to transmit, software can set the appropriate interrupt request bit in the Interrupt Controller to initiate a new transmit interrupt. Another alternative would be for the software to write the data to the Transmit Data Register instead of invoking the interrupt service routine.

14.1.4. Receiving Data Using Polled Method

Observe the following steps to configure the UART-LDD for polled data reception:

1. Write to the UART-LDD Baud Rate High and Low Byte registers to set the appropriate baud rate.
2. Enable the UART-LDD pin functions by configuring the associated GPIO port pins for alternate function operation.
3. If Multiprocessor Mode is appropriate, write to the UART-LDD Control 1 Register to enable Multiprocessor (9-bit) Mode functions.
4. Write to the UART-LDD Control 0 Register to:
 - a. Set the Receive Enable (REN) bit to enable the UART-LDD for data reception.

- b. If Multiprocessor Mode is not enabled, then enable parity (if appropriate), and select either even or odd parity.
5. Check the RDA bit in the UART-LDD Status 0 Register to determine if the Receive Data Register contains a valid data byte (indicated by a 1). If RDA is set to 1 to indicate available data, continue to [Step 6](#). If the Receive Data Register is empty (indicated by a 0), continue to monitor the RDA bit that is awaiting reception of the valid data.
6. Read data from the UART-LDD Receive Data Register. If operating in Multiprocessor (9-bit) Mode, further actions may be required depending on the Multiprocessor Mode bits MPMD[1:0].
7. Return to [Step 5](#) to receive additional data.

14.1.5. Receiving Data Using the Interrupt-Driven Method

The UART-LDD Receiver interrupt indicates the availability of new data (as well as error conditions). Observe the following steps to configure the UART-LDD receiver for interrupt-driven operation:

1. Write to the UART-LDD Baud Rate High and Low Byte registers to set the appropriate baud rate.
2. Enable the UART-LDD pin functions by configuring the associated GPIO port pins for alternate function operation.
3. Execute a DI instruction to disable interrupts.
4. Write to the Interrupt Control registers to enable the UART-LDD Receiver interrupt and set the appropriate priority.
5. Clear the UART-LDD Receiver interrupt in the applicable Interrupt Request Register.
6. Write to the UART-LDD Control 1 Register to enable Multiprocessor (9-bit) Mode functions, if appropriate.
 - a. Set the Multiprocessor Mode Select (MPEN) bit to enable Multiprocessor Mode.
 - b. Set the Multiprocessor Mode Bits, MPMD[1:0] to select the appropriate address matching scheme.
 - c. Configure the UART-LDD to interrupt on received data and errors or errors only (interrupt on errors only is unlikely to be useful for Z8 Encore! devices without a DMA block).
7. Write the device address to the Address Compare Register (automatic Multiprocessor modes only).
8. Write to the UART-LDD Control 0 Register to:
 - a. Set the receive enable (REN) bit to enable the UART-LDD for data reception.

- b. If Multiprocessor Mode is not enabled, then enable parity (if appropriate) and select either even or odd parity.
9. Execute an EI instruction to enable interrupts.

The UART-LDD is now configured for interrupt-driven data reception. When the UART-LDD Receiver interrupt is detected, the associated ISR performs the following:

1. Checks the UART-LDD Status 0 Register to determine the source of the interrupt—error, break, or received data.
2. If the interrupt is due to data available, read the data from the UART-LDD Receive Data Register. If operating in Multiprocessor (9-bit) Mode, further actions may be required depending on the Multiprocessor Mode bits MPMD[1:0].
3. Execute the IRET instruction to return from the ISR and await more data.

14.1.6. Clear To Send Operation

The Clear To Send ($\overline{\text{CTS}}$) pin, if enabled by the CTSE bit of the UART-LDD Control 0 Register, performs flow control on the outgoing transmit data stream. The Clear To Send ($\overline{\text{CTS}}$) input pin is sampled one system clock before any new character transmission begins. To delay transmission of the next data character, an external receiver must reduce $\overline{\text{CTS}}$ at least one system clock cycle before a new data transmission begins. For multiple character transmissions, this operation is typically performed during the stop bit transmission. If $\overline{\text{CTS}}$ stops in the middle of a character transmission, the current character is sent completely.

14.1.7. External Driver Enable

The UART-LDD provides a Driver Enable (DE) signal for off-chip bus transceivers. This feature reduces the software overhead associated using a GPIO pin to control the transceiver when communicating on a multitransceiver bus, such as RS-485.

Driver Enable is a programmable polarity signal which envelopes the entire transmitted data frame including parity and stop bits, as illustrated in Figure 30. The Driver Enable signal asserts when a byte is written to the UART-LDD Transmit Data Register. The Driver Enable signal asserts at least one bit period, and no greater than two bit periods, before the start bit is transmitted. This assertion allows a set-up time to enable the transceiver. The Driver Enable signal deasserts one system clock period after the last stop bit is transmitted. This system clock delay allows both time for data to clear the transceiver before disabling it, as well as the ability to determine if another character follows the current character. In the event of back-to-back characters (new data must be written to the Transmit Data Register before the previous character is completely transmitted), the DE signal is not deasserted between characters. The DEPOL bit in the UART-LDD Control Register 1 sets the polarity of the Driver Enable signal.

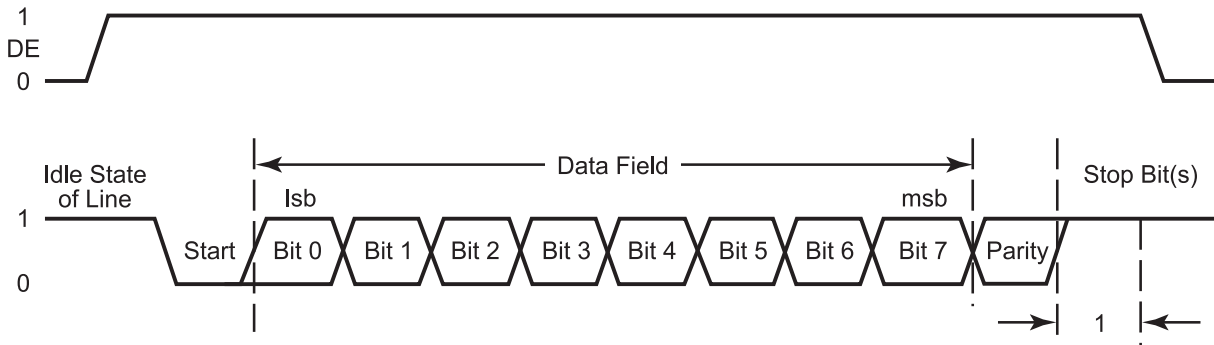

Figure 30. UART-LDD Driver Enable Signal Timing with One Stop Bit and Parity

The Driver Enable to start bit set-up time is calculated as follows:

$$\frac{1}{\text{Baud Rate (Hz)}} \leq \text{DE to Start Bit Set-up Time(s)} \leq \frac{2}{\text{Baud Rate (Hz)}}$$

14.1.8. UART-LDD Special Modes

The special modes of the UART-LDD are:

- Multiprocessor Mode
- LIN Mode
- DALI Mode
- DMX Mode

The UART-LDD features a common control register (Control 0) that has a unique register address and several mode-specific control registers (Multiprocessor Control, Noise Filter Control, LIN Control, DALI Control, and DMX Control) that share a common register address (Control 1). When the Control 1 address is read or written, the MSEL[2:0] (Mode Select) field of the Mode Select and Status Register determines which physical register is accessed. Similarly, there are mode-specific status registers, one of which is returned when the Status 0 Register is read, depending on the MSEL field.

14.1.9. Multiprocessor Mode

The UART-LDD features a Multiprocessor (9-bit) mode that uses an extra (9th) bit for selective communication when a number of processors share a common UART bus. In Multiprocessor Mode (also referred to as 9-bit mode), the multiprocessor (MP) bit is trans-

mitted immediately following the 8 bits of data and immediately preceding the stop bit(s) as shown in Figure 31.

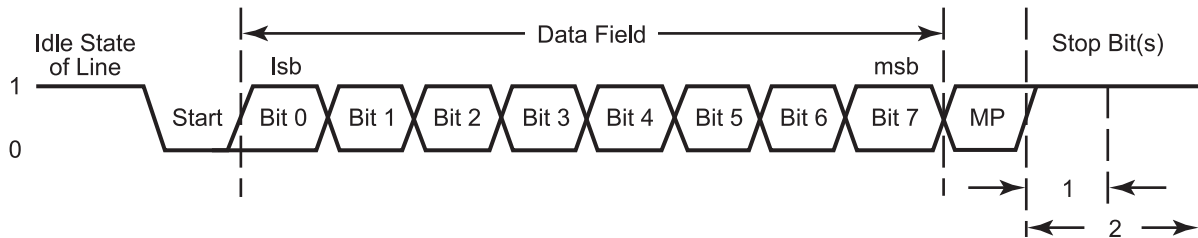

Figure 31. UART-LDD Asynchronous Multiprocessor Mode Data Format

In Multiprocessor (9-bit) Mode, the Parity bit location (9th bit) becomes the Multiprocessor control bit. The UART-LDD Control 1 and Status 1 registers provide Multiprocessor (9-bit) Mode control and status information. If an automatic address matching scheme is enabled, the UART-LDD Address Compare Register holds the network address of the device.

14.1.9.1. Multiprocessor Mode Receive Interrupts

When Multiprocessor (9-bit) Mode is enabled, the UART-LDD processes only frames addressed to it. Determining whether a frame of data is addressed to the UART-LDD can be made in hardware, software or a combination of the two, depending on the multiprocessor configuration bits. In general, the address compare feature reduces the load on the CPU, because it is not required to access the UART-LDD when it receives data directed to other devices on the multinode network. The following three Multiprocessor modes are available in hardware:

- Interrupt on all address bytes
- Interrupt on matched address bytes and correctly framed data bytes
- Interrupt only on correctly framed data bytes

These modes are selected with MPMD[1:0] in the UART-LDD Control 1 Register. For all Multiprocessor modes, the MPEN bit of the UART-LDD Control 1 Register must be set to 1.

The first scheme is enabled by writing 01b to MPMD[1:0]. In this mode, all incoming address bytes cause an interrupt, while data bytes never cause an interrupt. The interrupt service routine checks the address byte which triggered the interrupt. If it matches the UART-LDD address, the software clears MPMD[0]. At this point, each new incoming byte interrupts the CPU. The software determines the end of the frame and checks for it by reading the MPRX bit of the UART-LDD Status 1 Register for each incoming byte. If

MPRX=1, a new frame begins. If the address of this new frame is different from the UART-LDD's address, then MPMD[0] must be set to 1 by software, causing the UART-LDD interrupts to go inactive until the next address byte. If the new frame's address matches the UART-LDD's address, then the data in the new frame is also processed.

The second scheme is enabled by setting MPMD[1:0] to 10b and writing the UART-LDD's address into the UART-LDD Address Compare Register. This mode introduces more hardware control, interrupting only on frames that match the UART-LDD's address. When an incoming address byte does not match the UART-LDD's address, it is ignored. All successive data bytes in this frame are also ignored. When a matching address byte occurs, an interrupt is issued and further interrupts occur on each successive data byte. The first data byte in the frame has NEWFRM=1 in the UART-LDD Status 1 Register. When the next address byte occurs, the hardware compares it to the UART-LDD's address. If there is a match, the interrupt occurs and the NEWFRM bit is set to the first byte of the new frame. If there is no match, the UART-LDD ignores all incoming bytes until the next address match.

The third scheme is enabled by setting MPMD[1:0] to 11b and by writing the UART-LDD's address into the UART-LDD Address Compare Register. This mode is identical to the second scheme, except that there are no interrupts on address bytes. The first data byte of each frame remains accompanied by a NEWFRM assertion.

14.1.10. LIN Protocol Mode

The Local Interconnect Network (LIN) protocol, as supported by the UART-LDD module, is defined in Revision 2.0 of the LIN Specification Package. The LIN protocol specification covers all aspects of transferring information between LIN master and slave devices using *message frames*, including error detection and recovery, SLEEP Mode and wake up from SLEEP Mode. The UART-LDD hardware in LIN Mode provides character transfers to support the LIN protocol including break transmission and detection, wake-up transmission and detection and slave autobauding. Part of the error detection of the LIN protocol is for both master and slave devices to monitor their receive data when transmitting. If the receive and transmit data streams do not match, the UART-LDD asserts the PLE bit (i.e., the physical layer error bit in the Status 0 Register). The *message frame* time-out aspect of the protocol depends on software requiring the use of an additional general-purpose timer. The LIN Mode of the UART-LDD does not provide any hardware support for computing/verifying the checksum field or verifying the contents of the identifier field. These fields are treated as data and are not interpreted by hardware. The checksum calculation/verification can easily be implemented in software via the Add with Carry (ADC) instruction.

The LIN bus contains a single Master and one or more slaves. The LIN master is responsible for transmitting the message frame header which consists of the Break, Synch and Identifier fields. Either the master or one of the slaves transmits the associated *response* section of the message which consists of data characters followed by a checksum character.

In LIN Mode, the interrupts defined for normal UART operation still apply with the following changes:

- A Parity Error (i.e., the PE bit in the Status 0 Register) is redefined as the Physical Layer Error (PLE) bit. The PLE bit indicates that receive data does not match transmit data when the UART-LDD is transmitting. This definition applies to both Master and Slave operating modes.
- The Break Detect interrupt (i.e., the BRKD bit in the Status 0 Register) indicates when a break is detected by the slave (i.e., a break condition for at least 11 bit times). Software can use this interrupt to start a timer checking for message frame time-out. The duration of the break can be read in the RxBreakLength[3:0] field of the Mode Select and Status Register.
- The Break Detect interrupt (BRKD bit in Status 0 Register) indicates when a wake-up message has been received, if the UART-LDD is in a LIN Sleep state.
- In LIN Slave Mode, if the BRG counter overflows while measuring the autobaud period (from the start bit to the beginning of bit 7 of the autobaud character), an Overrun Error is indicated (OE bit in the Status 0 Register). In this case, software sets the Lin-State field back to 10b, where the slave ignores the current message and waits for the next break. The Baud Reload High and Low registers are not updated by hardware if this autobaud error occurs. The OE bit is also set if a data overrun error occurs.

14.1.10.1. LIN System Clock Requirements

The LIN Master provides the timing reference for the LIN network and is required to have a clock source with a tolerance of $\pm 0.5\%$. A slave with autobaud capability is required to have a baud clock matching the master oscillator within $\pm 14\%$. The slave nodes autobaud to lock onto the master timing reference with an accuracy of $\pm 2\%$. If a slave does not contain autobaud capability, it must include a baud clock which deviates from the masters by not more than $\pm 1.5\%$. These accuracy requirements must include the effects such as voltage and temperature drift during operation.

Before sending/receiving messages, the Baud Reload High/Low registers must be initialized. Unlike standard UART modes, the Baud Reload High/Low registers must be loaded with the baud interval rather than 1/16 of the baud interval.

To autobaud with the required accuracy, the LIN slave system clock must be at least 100 times the baud rate.

14.1.10.2. LIN Mode Initialization and Operation

LIN Protocol Mode is selected by setting either the LIN Master (LMST) or LIN Slave (LSLV) and, optionally (for the LIN slave), the Autobaud Enable (ABEN) bits in the LIN Control Register. To access the LIN Control Register, the Mode Select (MSEL) field of the UART-LDD Mode Select/Status Register must be = 010b. The UART-LDD Control 0 Register must be initialized with TEN=1, REN=1 and all other bits=0.

In addition to the LMST, LSLV and ABEN bits in the LIN Control Register, a LinState[1:0] field exists which defines the current state of the LIN logic. This field is initially set by software. In the LIN Slave Mode, the LinState field is updated by hardware as the slave moves through the Wait For Break, AutoBaud and Active states.

14.1.10.3. LIN Master Mode Operation

LIN Master Mode is selected by setting LMST=1, LSLV=0, ABEN=0 and LinState[1:0]=11b. If the LIN bus protocol indicates the bus is required go into the LIN Sleep state, the LinState[1:0] bits must be set to 00b by software.

The break is the first part of the message frame transmitted by the master, consisting of at least 13 bit periods of logical zero on the LIN bus. During initialization of the LIN master, the duration (in bit times) of the break is written to the TxBreakLength field of the LIN Control Register. The transmission of the break is performed by setting the SBRK bit in the Control 0 Register. The UART-LDD starts the break after the SBRK bit is set and any character transmission currently underway has completed. The SBRK bit is deasserted by hardware until the break is completed.

If it is necessary to generate a break longer than 15 bit times, the SBRK bit can be used in normal UART Mode, in which software times the duration of the break.

The Synch character is transmitted by writing a 55h to the Transmit Data Register (TDRE must=1 before writing). The Synch character is not transmitted by the hardware until the break is complete.

The identifier character is transmitted by writing the appropriate value to the Transmit Data Register (TDRE must=1 before writing).

If the master is sending the response portion of the message, these data and checksum characters are written to the Transmit Data Register when the TDRE bit asserts. If the Transmit Data Register is written after TDRE asserts, but before TXE asserts, the hardware inserts one or two stop bits between each character as determined by the stop bit in the Control 0 Register. Additional idle time occurs between characters, if TXE asserts before the next character is written.

If the selected slave is sending the response portion of the frame to the master, each receive byte will be signalled by the receive data interrupt (the RDA bit will be set in the Status 0 Register). If the selected slave is sending the response to a different slave, the master can ignore the response characters by deasserting the REN bit in the Control 0 Register until the frame time slot is completed.

14.1.10.4. LIN Sleep Mode

While the LIN bus is in the *sleep state*, the CPU can either be in low-power Stop Mode, in Halt Mode, or in normal operational state. Any device on the LIN bus can issue a wake-up message if it requires the master to initiate a LIN message frame. Following the wake-up message, the master wakes up and initiates a new message. A wake-up message is accom-

plished by pulling the bus Low for at least 250 μ s but less than 5 ms. Transmitting a 00h character is one way to transmit the wake-up message.

If the CPU is in Stop Mode, the UART-LDD is not active and the wake-up message must be detected by a GPIO edge detect Stop-Mode Recovery. The duration of the Stop-Mode Recovery sequence can preclude making an accurate measurement of the wake-up message duration.

If the CPU is in a halt or operational mode, the UART-LDD (if enabled) times the duration of the wake-up and provides an interrupt following the end of the break sequence if the duration is ≥ 3 bit times. The total duration of the wake-up message in bit times can be obtained by reading the RxBreakLength field in the Mode Select and Status Register. After a wake-up message has been detected, the UART-LDD can be placed (by software) either into LIN Master or LIN Slave Wait for Break states, as appropriate. If the break duration exceeds 15 bit times, the RxBreakLength field contains the value Fh. If the UART-LDD is disabled, wake-up message is detected via a port pin interrupt and timed by software. If the device is in Stop Mode, the High to Low transition on the port pin will bring the device out of Stop Mode.

The *LIN Sleep state* is selected by software setting LinState[1:0]=00. The decision to move from an active state to sleep state is based on the LIN messages as interpreted by software.

14.1.10.5. LIN Slave Operation

LIN Slave Mode is selected by setting LMST=0, LSLV=1, ABEN=1 or 0 and LinState[1:0]=01b (Wait for Break state). The LIN slave detects the start of a new message by the break which appears to the slave as a break of at least 11 bit times in duration. The UART-LDD detects the break and generates an interrupt to the CPU. The duration of the break is observable in the RxBreakLength field of the Mode Select and Status Register. A break of less than 11 bit times in duration does not generate a break interrupt when the UART-LDD is in a Wait for Break state. If the break duration exceeds 15 bit times, the RxBreakLength field contains the value Fh.

Following the break, the UART-LDD hardware automatically transits to the *Autobaud state*, where it autobauds by timing the duration of the first 8 bit times of the Synch character as defined in the LIN standard. The duration of the autobaud period is measured by the BRG Counter which will update every 8th system clock cycle between the start bit and the beginning of bit 7 of the autobaud sequence. At the end of the autobaud period, the duration measured by the BRG counter (auto baud period divided by 8) is automatically transferred to the Baud Reload High and Low registers if the ABEN bit of the LIN Control Register is set. If the BRG Counter overflows before reaching the start of bit 7 in the autobaud sequence the Autobaud Overrun Error interrupt occurs, the OE bit in the Status 0 Register is set and the Baud Reload registers are not updated. To autobaud within 2% of the master's baud rate, the slave system clock must be a minimum of 100 times the baud rate. To avoid an autobaud overrun error, the system clock must not be greater than 2^{19}

times the baud rate (16 bit counter following 3-bit prescaler when counting the 8 bit times of the Autobaud sequence).

Following the Synch character, the UART-LDD hardware transits to the *Active* state, in which the identifier character is received and the characters of the *response* section of the message are sent or received. The slave remains in this *Active* state until a break is received or software forces a state change. After it is in an *Active* state (i.e., autobaud has completed), a break of 10 or more bit times is recognized and causes a transition to the Autobaud state.

If the identifier character indicates that this slave device is not participating in the message, the software sets the `LinState[1:0]=01b` (Wait for Break state) to ignore the remainder of the message. No further receive interrupts will occur until the next break.

14.1.11. DALI Protocol Mode

The Digital Addressable Lighting Interface (DALI) protocol, as supported by the UART-LDD module, is defined in IEC62386-201. This DALI protocol specification covers all aspects of transferring information between DALI master and DALI slave devices. The UART-LDD hardware provides character transfers to support the DALI protocol, including biphasic encoding and decoding, message formation, and slave message address extraction for matching with the comparison address (`COMP_ADDR`).

Forward messages from a DALI master to a DALI slave are typically 19-bit messages consisting of a start bit, an 8-bit address, 8-bit data, and 2 stop bits. The start bit, address byte, and data byte are biphasic encoded; stop bits are not biphasic encoded. Backward messages from a slave to a master are typically 11 bits consisting of 1 start bit, 8 data bits and 2 stop bits. The slave transmits only upon the request of the master. The DALI start bit is encoded as a logical 1 (a Low to High transition) and the stop bits are High levels. The DALI standard frames and biphasic bit encoding are shown in Figure 32.

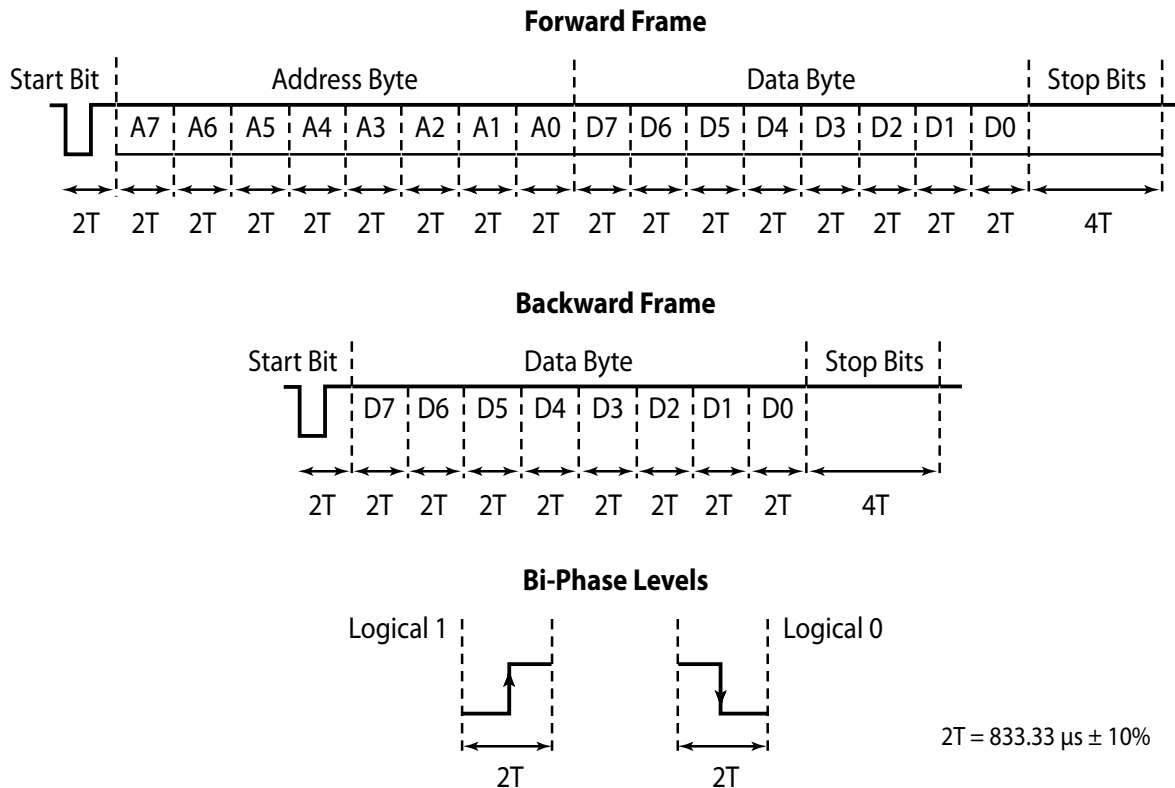

Figure 32. UART-LDD DALI Standard Frames and Biphase Bit Encoding

In DALI Mode, the interrupts defined for normal UART operation still apply, but with the following changes:

- A Parity Error (i.e., the PE bit in the Status 0 Register) is replaced with a biphase error, BPE, which indicates that there was a biphase encode error
- The Break Detect interrupt (i.e., the BRKD bit in the Status 0 Register) is not set
- Framing error checking occurs only for single-byte transfers (i.e, MULTRXE=0 in the DALI Control Register)

14.1.11.1. DALI Clock Requirements

Both the DALI master and DALI slaves are required to have a nominal 1.2 kbit/s bit rate with a tolerance of ±10%.

Before sending/receiving messages, the Baud Reload High/Low registers must be initialized. Unlike standard UART modes, the Baud Reload High/Low registers must be loaded with 1/32 of the baud interval rather than 1/16 of the baud interval.

14.1.11.2. DALI Mode Initialization and Operation

DALI Protocol Mode is selected by setting either the MULTTXE (multiple-byte transmit enable) or MULTRXE (multiple-byte receive enable) in the DALI Control Register. To access the DALI Control Register, the MSEL (Mode Select) field of the UART-LDD Mode Select/Status Register must be=100b. The UART-LDD Control 0 Register must be initialized. For DALI transmit operation, configure TEN=1, STOP=1 and all other bits=0. For DALI receive operation, configure REN=1, STOP=1 and all other bits=0.

In the DALI Control Register, several bits affect both transmit and receive operation:

Biphase Encoding Enable (BPEN). BPEN should be set for DALI operation.

DALI Biphase Encoding (BPENC). BPENC has an effect only if BPEN=1. When BPENC=0, DALI encoding is performed such that logic 0 is encoded as biphase 1→0 and logic 1 is encoded as biphase 0→1. When BPENC=1, alternate encoding is performed such that logic 0 is encoded as biphase 0→1 and logic 1 is encoded as biphase 1→0.

Start Bit Polarity (STRTPOL). The start bit value, logic 0 or logic 1, matches the value of this bit. STRTPOL is typically set for DALI.

Bit Order (BITORD). Standard UART bit order is selected when BITORD=0 and the LSB (TxD[0]/RxD[0]) is transmitted/received first. DALI bit order is selected when BITORD=1 and the MSB (TxD[7]/RxD[7]) is transmitted/received first.

DALI Control Register bits that affect only transmit or receive operations are described in the following sections.

14.1.11.3. DALI Transmit Operation

The UART-LDD Control 0 Register must be initialized. For DALI transmit operation, configure TEN=1, STOP=1 and all other bits=0. When the MSEL=100b (Mode Select) in the DALI Control Register, DALI transmit operation can be configured for single-byte or multiple-byte transmission. If MULTTXE=0 in the DALI Control Register, single-byte transmit is selected and stop bits will be transmitted after each transmitted byte. This setting is typically selected for DALI slave response messages that are transmitted to the master.

If MULTTXE=1 in the DALI Control Register, multiple-byte transmit is selected and stop bits will be transmitted only after the last transmitted byte. This setting is typically selected for DALI master operation to send an address byte, followed by one or more data bytes. When the UART-LDD Transmit Data Register is written, the UART-LDD will send a start bit, followed by the 8 bits in the UART-LDD Transmit Data Register. As the data is transmitted, the UART-LDD will assert an interrupt request for the next data byte. If the Transmit Data Register is written after TDRE asserts – but before TXE asserts – the hardware will transmit the character in the Transmit Data Register without the intervening stop bits. If TXE asserts before the next character is written in the Transmit Data Register, the DALI Master will transmit two stop bits after the last data bit.

Collision detection is enabled by setting CLSNE in the DALI Control Register. This setting is useful for DALI masters in systems with more than one master, because it is possible for more than one master to start a transmission at the same time. When CLSNE is set, the UART-LDD monitors its own transmission. Because Low (i.e., 0) is the dominant state on the DALI bus, collision detection effectively checks to determine if High (i.e., 1) state transmissions are not corrupted. If a collision is detected, CLSN is set in the Status Register and an interrupt request is generated.

14.1.11.4. DALI Receive Operation

The UART-LDD Control 0 Register must be initialized. For DALI receive operation, configure REN=1, STOP=1 and all other bits=0. When the MSEL=100b (Mode Select) in the DALI Control Register, DALI receive operation can be configured for single-byte or multiple-byte reception. If MULTRXE=0 in the DALI Control Register, single-byte receive is selected, and stop bits will be expected after each transmitted byte. This setting is typically selected for a DALI master that will receive a slave response message. Address match checking is not performed when MULTRXE=0.

If MULTRXE=1 in the DALI Control Register, multiple-byte receive is selected, and stop bits will be received to signal the end of the transmission. This setting is typically selected for DALI slave operation to receive an address byte followed by one or more data bytes.

If PARTRXE is set, and if a partial byte has been received, it will be loaded into the UART-LDD Receive Data Register upon receiving the number of stop bits selected by STOP in the UART-LDD Control 0 Register. Software should determine which bits in the received byte are valid.

When MULTRXE=1 in the DALI Control Register, the start bit is detected as the beginning of a new message. The UART-LDD decodes the first byte received as an address, and a status is provided with MODESTAT in the UART-LDD Mode Select and Status Register, as follows:

0–7Fh. Short address, each DALI slave is assigned a short address (MODESTAT=001).

80–9Fh. Group address (MODESTAT=010).

A0–FDh. Special or unrecognized command (MODESTAT=101).

FE–FFh. Broadcast (MODESTAT=100).

Address matching for short addresses is performed by hardware, which compares the short address in the received address byte to the value of COMP_ADDR[5:0] stored in the Comparison Address Register. If a short address is received that does not match the value of COMP_ADDR[5:0], the message is ignored.

Each DALI slave can belong to as many as 4 groups of the 16 available groups. Software should determine whether the slave belongs to the group for which the message is intended, and whether to process the message.

Except for cases in which messages with short addresses do not match the value of COMP_ADDR[5:0], when each byte is received including the first byte, RDA is set in the UART-LDD Status Register, and an interrupt request is generated.

14.1.11.5. DALI Receive During Stop Mode

While the DALI bus is idle, the DALI receiver can either be in low-power Stop Mode, in Halt Mode, or in a normal operational state. While the receiver is in Stop Mode, the UART-LDD is not active, and the start bit must be detected by a GPIO edge-detect Stop-Mode Recovery. A High-to-Low transition on the port pin can be used to bring the device out of Stop Mode. When Stop-Mode Recovery is completed, and if enabled, the UART-LDD will recognize the start bit. The duration of the Stop-Mode Recovery sequence can preclude recognizing the start bit.

14.1.12. DMX Protocol Mode

The Asynchronous Serial Digital Data Transmission Standard for Controlling Lighting Equipment and Accessories (DMX) protocol, as supported by the UART-LDD module, is defined in ANSI E1.11-2008. This DMX protocol specification covers all aspects of transferring information from a DMX master to DMX slave devices. The UART-LDD hardware provides character transfers to support the DMX protocol, including break transmission and detection, mark after break transmission and detection, and tracking by the DMX slave of the received data slot number for matching with the comparison address (COMP_ADDR). The DMX mode of the UART-LDD also provides hardware support for recognizing a null start code.

The DMX bus contains a single master and one or more slaves. The DMX protocol consists of a reset sequence followed by up to 512 data slots. The DMX master is responsible for transmitting the reset sequence, which consists of the break, a mark after break, and a start code. The Master then transmits up to 512 DMX data slots. When the start code is the null start code, data values from 0 to 255 are valid. Furthermore, each slave must be configured to identify the data slot(s) containing data intended for it. After transmitting the appropriate number of data slots, the DMX master asserts a mark before break. The DMX frame and data slot are shown in Figure 33.

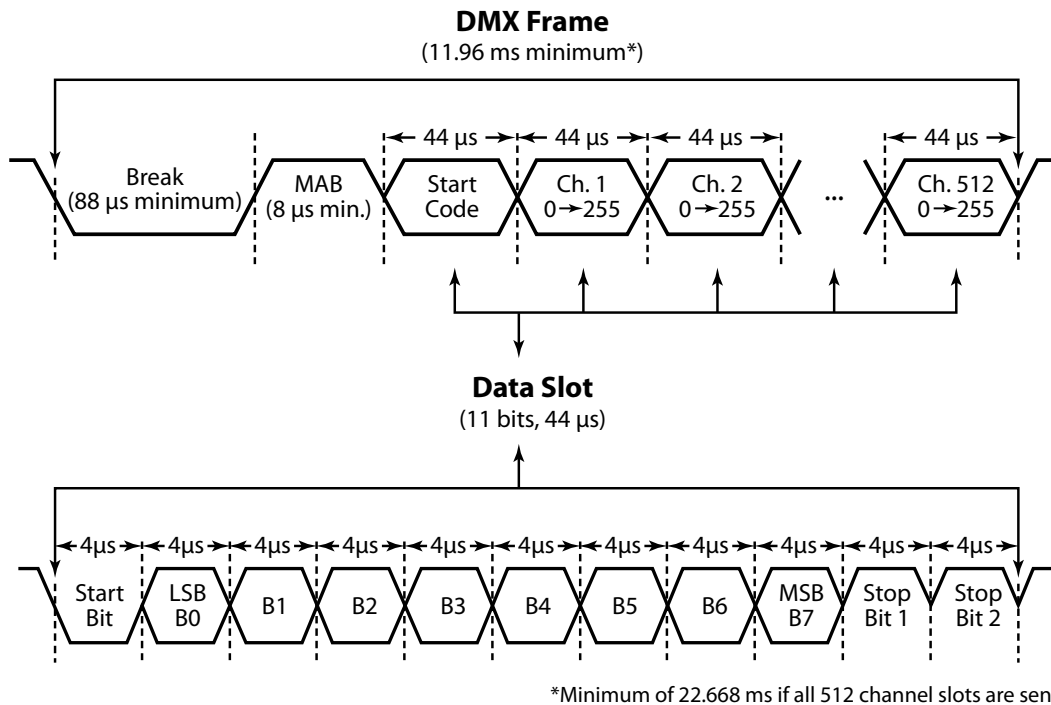

Figure 33. UART-LDD DMX Frame and Data Slot

In DMX Mode, the interrupts defined for normal UART operation still apply, but with the following changes:

- A Parity Error (i.e., the PE bit in the Status 0 Register) is not applicable. Parity Enable (i.e., the PEN bit in the Control 0 Register) is ignored in DMX Mode.
- Framing error checking is not performed; therefore, the framing error status bit (i.e., the FE bit in the Status 0 Register) is reserved in DMX Mode.
- The Break Detect interrupt (i.e., the BRKD bit in the Status 0 Register) indicates when a break is detected by the slave (a break condition for at least 22 bit times). Software can use this interrupt to start a timer checking for lost data input (loss of data tolerance).

14.1.12.1. DMX Clock Requirements

Both a DMX Master and DMX slaves are required to have a nominal 250 kbit/s bit rate with a tolerance of $\pm 2\%$. Before sending/receiving messages, the Baud Reload High/Low registers must be initialized.

14.1.12.2. DMX Mode Initialization and Operation

DMX Protocol Mode is selected by setting either the DMXMST (DMX master) or DMXSLV (DMX slave) in the DMX Control Register. To access the DMX Control Register, the Mode Select (MSEL) field of the UART-LDD Mode Select/Status Register must be=101b. The UART-LDD Control 0 Register must be initialized. For DMX Master Mode operation, configure TEN=1, STOP=1, and all other bits=0. For DMX slave operation, configure REN=1, STOP=1, and all other bits=0.

14.1.12.3. DMX Master Mode Operation

When the MSEL= 101b (Mode Select) in the DMX Control Register, DMX Master Mode is selected by setting DMXMST=1 and DMXSLV=0 in the DMX Control Register.

The break is the first part of the DMX protocol transmitted by the master. Hardware can be selected to generate a break consisting of 24 bit periods of logical zero on the DMX bus by first setting AUTOBRK in the DMX Control Register with SBRK in the Control 0 Register cleared. The duration of the break is timed by hardware, and AUTOBRK is deasserted by hardware when the break is completed. Alternatively, if it is necessary to generate a break longer than 24 bit times, a break can be sent manually by first clearing AUTOBRK in the DMX Control Register, then setting SBRK in the Control 0 Register, waiting the appropriate duration, then clearing SBRK. In both cases, UART-LDD starts the break after AUTOBRK or SBRK is set, and any character transmission currently underway has completed.

The mark after break is transmitted automatically for four bit times at the conclusion of the break.

The start code should be written to the Transmit Data Register prior to the conclusion of a mark after break transmission. The start code can be written while generating either the mark before break, the break, or the mark after break, as long as TDRE=1 before writing.

If the Transmit Data Register is written after TDRE asserts but before TXE asserts, the hardware will transmit the character in the Transmit Data Register during the next slot. During each slot, the DMX master will insert a start bit prior to transmitting the character, and will insert two stop bits between each character if STOP=1 in the Control 0 Register. If TXE asserts before the next character is written in the Transmit Data Register, the DMX Master will transmit a mark before break.

14.1.12.4. DMX Slave Operation

When the MSEL= 101b (Mode Select) in the DMX Control Register, DMX Slave Mode is selected by setting DMXMST=0 and DMXSLV=1. The DMX slave detects the start of a new message by the break which appears to the slave as a break of at least 22 bit times in duration.

Following the break, the UART-LDD hardware automatically checks for a mark after a break lasting at least one bit time. When a mark after this break is detected, hardware will wait for the first slot to be transmitted, which commences with the start bit of the start code. The UART-LDD will also check for the break condition.

The UART-LDD DMX slave decodes the start code and, if it is the null start code, the UART-LDD counts data slots received until the received data slot number matches the value of COMP_ADDR stored in the Comparison Address Register and the DMX Control Register. The slave then receives the data slots. While the REN bit in the UxCTL0 Register remains set, the slave receives data slots until a mark before the break is received, and also receives the first byte of the break. After receiving the data slots assigned to the slave, clearing the REN bit in the UxCTL0 Register and then setting REN prevents further data reception and associated interrupts until after the next valid break. DMX receive status information is provided in the MODESTAT field of the UART-LDD Mode Select and Status Register.

The UART-LDD can be configured to generate an interrupt upon all received characters, or only upon characters received in data slots equal to or greater than the COMP_ADDR. When the characters in the data slots assigned to the slave have been received, a Wait for Break (WFBRK) can be set to inhibit further receive interrupts until after the next break. To learn more about DMX slave interrupt options, see the [Receiver Interrupts](#) section on page 251. Even if WFBRK is set, the Receive Data Register will continue to receive if the REN bit was not temporarily cleared after receiving the data slots assigned to the slave. In this case, a software handler based on the mode status bits in the UxMDSTAT Register should discard the Receive Data Register contents between the time the DMX break condition is detected and the reception of a start code is indicated.

14.1.12.5. DMX Slave During Stop Mode

While the DMX bus is in a mark after break condition, the DMX slave can either be in low-power Stop Mode, in Halt Mode, or in a normal operational state. While the slave is in Stop Mode, the UART-LDD is not active, and the break condition must be detected by a GPIO edge-detect Stop-Mode Recovery. A High-to-Low transition on the port pin can be used to bring the device out of Stop Mode. When Stop-Mode Recovery is completed, if enabled, the UART-LDD will time the duration of the break. If the UART-LDD is disabled, the duration of the break can be timed by software. The duration of the Stop-Mode Recovery sequence can preclude making an accurate measurement of a break duration.

14.1.13. UART-LDD Interrupts

The UART-LDD features separate interrupts for the transmitter and receiver. In addition, when the UART-LDD primary functionality is disabled, the Baud Rate Generator can also function as a basic timer with interrupt capability.

14.1.13.1. Transmitter Interrupts

The transmitter generates a single interrupt when the Transmit Data Register Empty (TDRE) bit is set to 1. This interrupt indicates that the transmitter is ready to accept new data for transmission. The TDRE interrupt occurs when the transmitter is initially enabled, and after the Transmit Shift Register has shifted out the first bit of a character. At this point, the Transmit Data Register can be written with the next character to send. As a

result of this write, 7 bit periods of latency are provided to load the Transmit Data Register before the Transmit Shift Register completes shifting the current character. Writing to the UART-LDD Transmit Data Register clears the TDRE bit to 0.

In addition, and while transmitting, the UART-LDD can detect a physical layer error (PLE) for LIN Protocol Mode and a collision error (CLSN) for DALI Protocol Mode. The UART-LDD will generate an interrupt if PLE is detected and if CLSN is detected while CLSNE is set.

14.1.13.2. Receiver Interrupts

The receiver generates an interrupt when any one of the following issues occur:

- A data byte has been received and is available in the UART-LDD Receive Data Register. This interrupt can be disabled independently of the other receiver interrupt sources via the RDAIRQ bit in the Multiprocessor Control Register, and is useful when using DMA to transfer UART-LDD data. The received data interrupt occurs after the receive character has been placed in the Receive Data Register. Software must respond to this received data available condition before the next character is completely received to avoid an overrun error.

► **Note:** In Multiprocessor Mode (MPEN=1), the receive-data interrupts are dependent on the multiprocessor configuration and the most recent address byte.

- A break is received
- A receive data overrun or LIN slave autobaud overrun error is detected
- A data framing error is detected
- A parity error is detected (e.g., if a physical layer error in LIN Mode occurs, software must disable parity error checking for DMX Mode)
- In DALI Mode, a collision error is detected while CLSNE is set in the DALI Control Register
- In DMX Mode, the following slave receive data interrupt events as selected by DMX-SIRQ while RDAIRQ is set and WFBRK is cleared:
 - Interrupt following each received byte.
 - Interrupt following each received byte in a slot \geq the slave address only if the first received byte was the null start.
 - Interrupt following the start code.
 - Interrupt following the start code and each received byte in a slot \geq the slave address only if the first received byte was the null start. If the first received byte was not the null start, interrupt following each received byte.

14.1.13.3. UART-LDD Overrun Errors

When an overrun error condition occurs, the UART-LDD prevents overwriting of the valid data currently in the Receive Data Register. The break detect and overrun status bits are not displayed until after the valid data has been read.

After the valid data has been read, the OE bit of the Status 0 Register is updated to indicate the overrun condition (and break detect, if applicable). The RDA bit is set to 1 to indicate that the Receive Data Register contains a data byte. However, because the overrun error occurred, this byte cannot contain valid data, and must be ignored. A BRKD bit indicates if the overrun is caused by a break condition on the line. After reading a status byte indicating an overrun error, the Receive Data Register must be read again to clear the error bits in the UART-LDD Status 0 Register.

In LIN Mode, an overrun error is signalled for receive-data overruns as described above, and in the LIN slave if the BRG Counter overflows during the autobaud sequence (the ATB bit will also be set in this case). There is no data associated with the autobaud overflow interrupt; however the Receive Data Register must be read to clear the OE bit. In this case, software must write a 10b to the LinState field, forcing the LIN slave back to a Wait for Break state.

14.1.13.4. UART-LDD Data- and Error-Handling Procedure

Figure 34 shows the recommended procedure for use in UART-LDD receiver interrupt service routines.

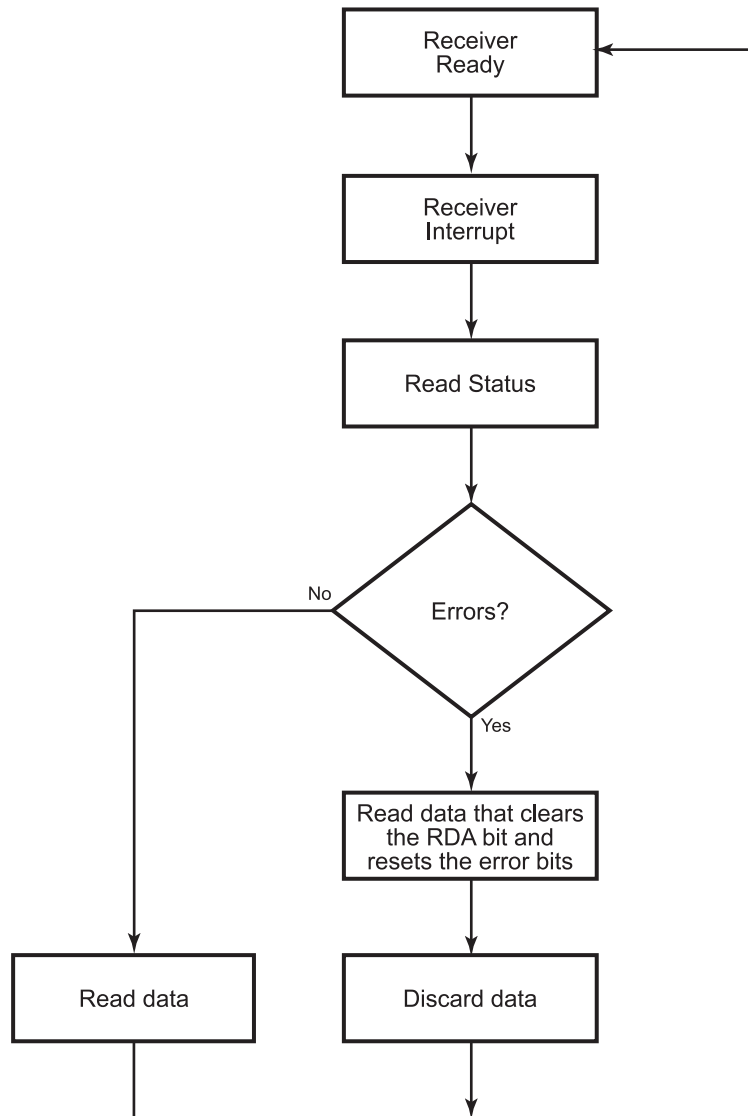

Figure 34. UART-LDD Receiver Interrupt Service Routine Flow

14.1.13.5. Baud Rate Generator Interrupts

If the BRGCTL bit of the Multiprocessor Control Register (UART-LDD Control 1 Register with MSEL=000b) is set and the REN bit of the Control 0 Register is 0. The UART-LDD Receiver interrupt asserts when the UART-LDD Baud Rate Generator reloads. This action allows the Baud Rate Generator to function as an additional counter, if the UART-LDD receiver functionality is not employed. The transmitter can be enabled in this mode.

14.1.14. UART-LDD and DMA Support

The UART-LDD will assert DMA RX request whenever receive data is available (RDA=1) and will deassert DMA RX request whenever the Receive Data Register is read by the DMA or software. When using DMA, it can be desirable to clear RDAIRQ so that interrupts occur on receive errors but not upon receive data.

The UART-LDD will assert DMA TX request whenever the Transmit Data Register is empty (TDRE=1) and will deassert DMA TX request whenever the Transmit Data Register is written by the DMA or software.

14.1.15. UART-LDD Baud Rate Generator

The UART-LDD Baud Rate Generator creates a lower frequency baud rate clock for data transmission. The input to the Baud Rate Generator is the system clock. The UART-LDD Baud Rate High and Low Byte registers combine to create a 16-bit baud rate divisor value (BRG[15:0]) that sets the data-transmission rate (baud rate) of the UART-LDD. The UART-LDD data rate for normal UART operation and DMX operation is calculated using the following equation:

$$\text{UART Data Rate (bits/s)} = \frac{\text{System Clock Frequency (Hz)}}{16 \times \text{UART Baud Rate Divisor Value}}$$

The UART-LDD data rate for LIN Mode UART operation is calculated using the following equation:

$$\text{UART Data Rate (bits/s)} = \frac{\text{System Clock Frequency (Hz)}}{\text{UART Baud Rate Divisor Value}}$$

The UART-LDD data rate for DALI Mode operation is calculated using the following equation:

$$\text{UART Data Rate (bits/s)} = \frac{\text{System Clock Frequency (Hz)}}{32 \times \text{UART Baud Rate Divisor Value}}$$

When the UART-LDD is disabled, the BRG functions as a basic 16-bit timer with interrupt on time-out. To configure the BRG as a timer with interrupt on time-out, follow the procedure below:

1. Disable the UART-LDD receiver by clearing the REN bit in the UART-LDD Control 0 Register to 0 (i.e., the TEN bit can be asserted; transmit activity can occur).
2. Load the appropriate 16-bit count value into the UART-LDD Baud Rate High and Low Byte registers.

3. Enable the BRG timer function and the associated interrupt by setting the BRGCTL bit in the UART-LDD Control 1 Register to 1.

14.2. Noise Filter

An included noise filter circuit filters noise on a digital input signal (such as UART Receive Data) before data is sampled by the block. This circuit is likely to be a requirement for protocols that will operate within a noisy environment.

The noise filter contains the following features:

- Synchronizes the receive input data to the System Clock
- Noise Filter Enable (NFEN) input selects whether the noise filter is bypassed (NFEN=0) or included (NFEN=1) in the receive data path
- Noise Filter Control (NFCTL[2:0]) input selects the width of the up/down saturating counter digital filter; the available width ranges from 4 to 11 bits
- The digital filter output features hysteresis
- Provides an active-Low *Saturated State* output, FiltSatB, which is used as an indication of the presence of noise

14.2.1. Architecture

Figure 35 shows an example of how the noise filter is integrated with the UART-LDD on a LIN network.

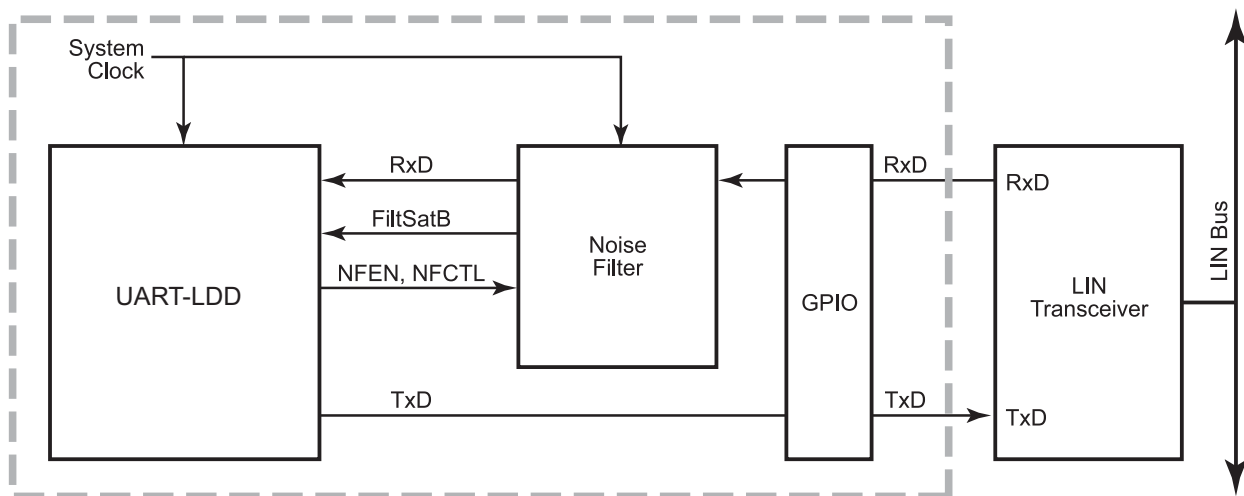

Figure 35. Noise Filter System Block Diagram

14.2.2. Operation

Figure 36 shows the operation of the noise filter both with and without noise. The noise filter in this example is a 2-bit up/down counter which saturates at 00b and 11b. A 2-bit counter is shown for convenience; the operation of wider counters is similar. The output of the filter switches from 1 to 0, when the counter counts down from 01b to 00b; this output switches from 0 to 1 when the counter counts up from 10b to 11b.

In this 2-bit counter example, the noise filter delays the receive data by three System Clock cycles. The receive data delay induced by the noise filter is a function of the counter width:

Filter delay = $2^n - 1$ System Clock cycles, where n is the counter width value selected by NFCTL.

The FiltSatB signal is checked when the filtered RxD is sampled in the center of the bit time. The presence of noise (FiltSatB=1 at the center of the bit time) does not mean that the sampled data is incorrect; instead, the filter is not in its *saturated* state of all ones or all zeroes. If FiltSatB=1, then RxD is sampled during a receive character and the NE bit in the ModeStatus[4:0] field is set. By observing this bit, an indication of the level of noise in the network can be obtained.

13.3. UART-LDD Control Register Definitions

The UART-LDD control registers support the UART-LDD and the noise filter.

13.3.1. UART-LDD 0–1 Transmit Data Registers

Data bytes written to the UART-LDD 0–1 Transmit Data Registers, shown in Table 121, are shifted out on the TxD pin. This write-only register shares a Register File address with the read-only UART-LDD 0–1 Receive Data Register.

Table 121. UART-LDD 0–1 Transmit Data Registers (UxTXD)

Bit	7	6	5	4	3	2	1	0
Field	TxD							
Reset	X	X	X	X	X	X	X	X
R/W	W	W	W	W	W	W	W	W
Address	U0TXD @ F40h, U1TXD @ F48h							

Note: W=Write; X=undefined; x = 0,1.

Bit	Description
[7:0] TxD	Transmit Data UART-LDD transmitter data byte to be shifted out through the TxD pin.

13.3.2. UART-LDD 0–1 Receive Data Registers

Data bytes received through the RxD pin are stored in the UART-LDD 0–1 Receive Data Registers, as shown in Table 122. This read-only register shares a Register File address with the write-only UART-LDD 0–1 Transmit Data Register.

Table 122. UART-LDD 0–1 Receive Data Registers (UxRXD)

Bit	7	6	5	4	3	2	1	0
Field	RxD							
Reset	X	X	X	X	X	X	X	X
R/W	R	R	R	R	R	R	R	R
Address	U0RXD @ F40h, U1RXD @ F48h							

Note: R=read; X=undefined; x = 0,1.

Bit	Description
[7:0] RxD	Receive Data UART-LDD receiver data byte from the RxD pin.

13.3.3. UART-LDD 0–1 Status 0 Registers

The UART-LDD 0–1 Status 0 registers identify the current UART-LDD operating configuration and status. Table 123 describes the Status 0 registers for standard UART Mode. These Status 0 registers are described for LIN Mode in Table 124, for DALI Mode in Table 125, and for DMX Mode in Table 126.

Table 123. UART-LDD 0–1 Status 0 Registers, Standard UART Mode (UxSTAT0)

Bit	7	6	5	4	3	2	1	0
Field	RDA	PE	OE	FE	BRKD	TDRE	TXE	CTS
Reset	0	0	0	0	0	1	1	X
R/W	R	R	R	R	R	R	R	R
Address	U0STAT0 @ F41h, U1STAT0 @ F49h							

Note: R = read; X = undefined; x = 0,1.

Bit	Description
[7] RDA	Receive Data Available This bit indicates that the UART-LDD Receive Data Register has received data. Reading the UART-LDD Receive Data Register clears this bit. 0: The UART-LDD Receive Data Register is empty. 1: There is a byte in the UART-LDD Receive Data Register.
[6] PE	Parity Error This bit indicates that a parity error has occurred. Reading the Receive Data Register clears this bit. 0: No parity error occurred. 1: A parity error occurred.
[5] OE	Overrun Error This bit indicates that an overrun error has occurred. An overrun occurs when new data is received and the Receive Data Register is not read. Reading the Receive Data Register clears this bit. 0: No overrun error occurred. 1: An overrun error occurred.
[4] FE	Framing Error This bit indicates that a framing error (no stop bit following data reception) was detected. Reading the Receive Data Register clears this bit. 0: No framing error occurred. 1: A framing error occurred.
[3] BRKD	Break Detect This bit indicates that a break occurred. If the data bits, parity/multiprocessor bit and stop bit(s) are all zeroes, then this bit is set to 1. Reading the Receive Data Register clears this bit. 0: No break occurred. 1: A break occurred.

Bit	Description (Continued)
[2] TDRE	Transmitter Data Register Empty This bit indicates that the Transmit Data Register is empty and ready for additional data. Writing to the Transmit Data Register resets this bit. 0: Do not write to the Transmit Data Register. 1: The Transmit Data Register is ready to receive an additional byte for transmission.
[1] TXE	Transmitter Empty This bit indicates that the Transmit Shift Register is empty and character transmission is finished. 0: Data is currently transmitting. 1: Transmission is complete.
[0] CTS	Clear to Send Signal When this bit is read it returns the level of the $\overline{\text{CTS}}$ signal. If LBEN=1, the $\overline{\text{CTS}}$ input signal is replaced by the internal Receive Data Available signal to provide flow control in a loopback mode. CTS only affects transmission if the CTSE bit=1.

Table 124. UART-LDD 0–1 Status 0 Registers, LIN Mode (UxSTAT0)

Bit	7	6	5	4	3	2	1	0
Field	RDA	PLE	OE	FE	BRKD	TDRE	TXE	ATB
Reset	0	0	0	0	0	1	1	0
R/W	R	R	R	R	R	R	R	R
Address	U0STAT0 @ F41h, U1STAT0 @ F49h							

Note: R=read; x = 0,1.

Bit	Description
[7] RDA	Receive Data Available This bit indicates that the Receive Data Register has received data. Reading the Receive Data Register clears this bit. 0: The Receive Data Register is empty. 1: There is a byte in the Receive Data Register.
[6] PLE	Physical Layer Error This bit indicates that transmit and receive data do not match when a LIN slave or master is transmitting. This could be by a fault in the physical layer or multiple devices driving the bus simultaneously. Reading the Status 0 Register or the Receive Data Register clears this bit. 0: Transmit and Receive data match. 1: Transmit and Receive data do not match.

Bit	Description (Continued)
[5] OE	<p>Receive Data and Autobaud Overrun Error</p> <p>This bit is set just as in normal UART operation if a receive data overrun error occurs. This bit is also set during LIN slave autobaud if the BRG counter overflows before the end of the autobaud sequence. This indicates that the receive activity is not an autobaud character or the master baud rate is too slow. The ATB status bit will also be set in this case. This bit is cleared by reading the Receive Data Register.</p> <p>0: No autobaud or data overrun error occurred. 1: An autobaud or data overrun error occurred.</p>
[4] FE	<p>Framing Error</p> <p>This bit indicates that a framing error (no stop bit following data reception) is detected. Reading the Receive Data Register clears this bit.</p> <p>0: No framing error occurred. 1: A framing error occurred.</p>
[3] BRKD	<p>Break Detect</p> <p>This bit is set in LIN Mode if:</p> <ul style="list-style-type: none"> • It is in LIN Sleep state and a break of at least 4 bit times occurred (wake-up event) or • It is in Slave Wait Break state and a break of at least 11 bit times occurred (break event) or • It is in Slave Active state and a break of at least 10 bit times occurs. Reading the Status 0 Register or the Receive Data Register clears this bit. <p>0: No LIN break occurred. 1: LIN break occurred.</p>
[2] TDRE	<p>Transmitter Data Register Empty</p> <p>This bit indicates that the Transmit Data Register is empty and ready for additional data. Writing to the Transmit Data Register resets this bit.</p> <p>0: Do not write to the Transmit Data Register. 1: The Transmit Data Register is ready to receive an additional byte for transmission.</p>
[1] TXE	<p>Transmitter Empty</p> <p>This bit indicates that the Transmit Shift Register is empty and character transmission is completed.</p> <p>0: Data is currently transmitting. 1: Transmission is complete.</p>
[0] ATB	<p>LIN Slave Autobaud Complete</p> <p>This bit is set in LIN Slave Mode when an autobaud character is received. If the ABIEN bit is set in the LIN Control Register, then a receive interrupt is generated when this bit is set. Reading the Status 0 Register clears this bit. This bit will be 0 in LIN Master Mode.</p>

Table 125. UART-LDD 0–1 Status 0 Registers, DALI Mode (UxSTAT0)

Bit	7	6	5	4	3	2	1	0
Field	RDA	BPE	OE	FE	CLSN	TDRE	TXE	CTS
Reset	0	0	0	0	0	1	1	X
R/W	R	R	R	R	R	R	R	R
Address	U0STAT0 @ F41h, U1STAT0 @ F49h							

Note: R=read; X=undefined; x = 0,1.

Bit	Description
[7] RDA	Receive Data Available This bit indicates that the UART-LDD Receive Data Register has received data. Reading the UART-LDD Receive Data Register clears this bit. 0: The UART-LDD Receive Data Register is empty. 1: There is a byte in the UART-LDD Receive Data Register.
[6] BPE	Biphase Error This bit indicates that a biphase error has occurred. Reading the Receive Data Register clears this bit. 0: No biphase error occurred. 1: A biphase error occurred. Biphase format data was expected, but both phases had the same value. This bit is set only if BPEN=1.
[5] OE	Overrun Error This bit indicates that an overrun error has occurred. An overrun occurs when new data is received and the Receive Data Register is not read. Reading the Receive Data Register clears this bit. 0: No overrun error occurred. 1: An overrun error occurred.
[4] FE	Framing Error This bit indicates that a framing error (no stop bit following data reception) was detected. Checking occurs only for single-byte transfers (MULTRXE=0 in the DALI Control Register). Reading the Receive Data Register clears this bit. 0: No framing error occurred. 1: A framing error occurred.
[3] CLSN	Collision Detect Error This bit indicates that a collision was detected. Reading the Receive Data Register clears this bit. 0: No collision was detected. 1: A collision was detected.
[2] TDRE	Transmitter Data Register Empty This bit indicates that the Transmit Data Register is empty and ready for additional data. Writing to the Transmit Data Register resets this bit. 0: Do not write to the Transmit Data Register. 1: The Transmit Data Register is ready to receive an additional byte for transmission.

Bit	Description (Continued)
[1] TXE	Transmitter Empty This bit indicates that the Transmit Shift Register is empty and character transmission is finished. 0: Data is currently transmitting. 1: Transmission is complete.
[0] CTS	Clear to Send Signal When this bit is read it returns the level of the $\overline{\text{CTS}}$ signal. If LBEN=1, the $\overline{\text{CTS}}$ input signal is replaced by the internal Receive Data Available signal to provide flow control in a loopback mode. CTS only affects transmission if the CTSE bit=1.

Table 126. UART-LDD 0–1 Status 0 Registers, DMX Mode (UxSTAT0)

Bit	7	6	5	4	3	2	1	0
Field	RDA	Reserved	OE	Reserved	BRKD	TDRE	TXE	CTS
Reset	0	0	0	0	0	1	1	X
R/W	R	R	R	R	R	R	R	R
Address	U0STAT0 @ F41h, U1STAT0 @ F49h							

Note: R=read; X=undefined; x = 0,1.

Bit	Description
[7] RDA	Receive Data Available This bit indicates that the UART-LDD Receive Data Register has received data. Reading the UART-LDD Receive Data Register clears this bit. 0: The UART-LDD Receive Data Register is empty. 1: There is a byte in the UART-LDD Receive Data Register.
[6]	Reserved This bit is reserved and must be programmed to 0.
[5] OE	Overrun Error This bit indicates that an overrun error has occurred. An overrun occurs when new data is received and the Receive Data Register is not read. Reading the Receive Data Register clears this bit. 0: No overrun error occurred. 1: An overrun error occurred.
[4]	Reserved This bit is reserved and must be programmed to 0.
[3] BRKD	Break Detect This bit indicates that a break occurred. If the break condition exists for at least 22 bit times (all bits are zero) then this bit is set to 1. Reading the Receive Data Register clears this bit. 0: No break occurred. 1: A break occurred.

Bit	Description (Continued)
[2] TDRE	Transmitter Data Register Empty This bit indicates that the Transmit Data Register is empty and ready for additional data. Writing to the Transmit Data Register resets this bit. 0: Do not write to the Transmit Data Register. 1: The Transmit Data Register is ready to receive an additional byte for transmission.
[1] TXE	Transmitter Empty This bit indicates that the Transmit Shift Register is empty and character transmission is finished. 0: Data is currently transmitting. 1: Transmission is complete.
[0] CTS	Clear to Send Signal When this bit is read it returns the level of the $\overline{\text{CTS}}$ signal. If LBEN=1, the $\overline{\text{CTS}}$ input signal is replaced by the internal Receive Data Available signal to provide flow control in a loopback mode. CTS only affects transmission if the CTSE bit=1.

13.3.4. UART-LDD 0–1 Mode Select and Status Registers

The UART-LDD 0–1 Mode Select and Status registers, shown in Table 127, contain mode select and status bits.

Table 127. UART-LDD 0–1 Mode Select and Status Registers (UxMDSTAT)

Bit	7	6	5	4	3	2	1	0
Field	MSEL			MODESTAT				
Reset	0	0	0	0	0	0	0	0
R/W	R/W	R/W	R/W	R	R	R	R	R
Address	U0MDSTAT @ F44h, U1MDSTAT @ F4Ch							

Note: R=read; R/W=read/write; x = 0,1.

Bit	Description
[7:5] MSEL	Mode Select This read/write field determines which control register is accessed when performing a write or read to the UART Control 1 Register address. This field also determines which status is returned in the Mode Status field when reading this register. 000: Multiprocessor and normal UART control/status. 001: Noise filter control/status. 010: LIN protocol control/status. 011: Reserved. 100: DALI protocol/status. 101: DMX protocol/status. 110: Reserved. 111: Reserved.

Bit	Description (Continued)
[4:0] MODESTAT	<p>Mode Status</p> <p>This read-only field returns status corresponding to one of four modes selected by MSEL. These four modes are described in Table 128 on page 265.</p> <p>When MSEL[2:0] is set to:</p> <p>000: Multiprocessor Mode status={NE,0,0,NEWFRM, MPRX}.</p> <p>001: Noise filter status={NE,0,0,0,0}.</p> <p>010: LIN Mode status={NE, RxBreakLength}.</p> <p>011: Reserved.</p> <p>100: DALI Mode status={RDA, CLSN,ADDRD}.</p> <p>101: DMX Mode status={RDA, NullStartCode, NonNullStartCode, SlvAddrMatch, MABState}.</p> <p>110: Reserved.</p> <p>111: Reserved</p>

Table 128. Mode Status Fields

Multiprocessor Mode Status Field; MSEL=000b	<p>New Frame (NEWFRM)</p> <p>Status bit denoting the start of a new frame. Reading the UART-LDD Receive Data Register resets this bit to 0.</p> <p>0: The current byte is not the first data byte of a new frame.</p> <p>1: The current byte is the first data byte of a new frame.</p> <p>Multiprocessor Receive (MPRX)</p> <p>Returns the value of the last multiprocessor bit received. Reading from the UART-LDD Receive Data Register resets this bit to 0.</p> <p>Noise Event (NE)</p> <p>This bit is asserted if digital noise is detected on the receive data line when the data is sampled (center of bit-time). If this bit is set, it does not mean that the receive data is corrupted (though it can be in extreme cases), means that one or more of the noise filter data samples near the center of the bit-time did not match the average data value.</p>
Digital Noise Filter Mode Status Field; MSEL=001b	<p>Noise Event (NE)</p> <p>See the NE description in this table for Multiprocessor Mode Status Field.</p>
LIN Mode Status Field; MSEL=010b	<p>Noise Event (NE)</p> <p>See description in this table for Multiprocessor Mode Status Field.</p> <p>RxBreakLength</p> <p>LIN Mode received break length. This field can be read following a break (LIN wake-up or break) so that the software can determine the measured duration of the break. If the break exceeds 15 bit times the value saturates at 1111b.</p>

Table 128. Mode Status Fields

<p>DALI Mode Status Field; MSEL=100b</p>	<p>Receive Data Available (RDA) This bit is identical to RDA in the UART-LDD Status 0 Register.</p> <p>Collision (CLSN) This bit is identical to CLSN in the UART-LDD Status 0 Register in DALI Mode.</p> <p>Address Detect (ADDRD) This field indicates the address detected by the UART-LDD block for the current message. 001: Short address match. 010: Group address. 100: Broadcast. 101: Special or unrecognized command. All other bits are reserved.</p>
<p>DMX Mode Status Field; MSEL=101b</p>	<p>Receive Data Available (RDA) This bit is identical to RDA in the UART-LDD Status 0 Register.</p> <p>Null Start Code Received (NullStartCode) This bit is asserted upon detecting a null start code and is cleared when reception of the frame ends.</p> <p>Non-Null Start Code Received (NonNullStartCode) This bit is asserted upon detecting a non-null start code and is cleared when reception of the frame ends.</p> <p>Slave Address Match (SlvAddrMatch) This bit is asserted upon detecting slave address match and is cleared when reception of the frame ends.</p> <p>Mark Before/After Break Condition (MABState) This bit is asserted while the Mark Before/After Break Condition is detected.</p>

13.3.5. UART-LDD 0–1 Control 0 Registers

The UART-LDD 0–1 Control 0 registers, shown in Table 129, configure the basic properties of UART-LDD’s transmit and receive operations. A more detailed discussion of each bit follows the table.

Table 129. UART-LDD 0–1 Control 0 Registers (UxCTL0)

Bit	7	6	5	4	3	2	1	0
Field	TEN	REN	CTSE	PEN	PSEL	SBRK	STOP	LBEN
Reset	0	0	0	0	0	0	0	0
R/W	R/W	R/W	R/W	R/W	R/W	R/W	R/W	R/W
Address	U0CTL0 @ F42h, U1CTL0 @ F4Ah							

Note: R/W=read/write; x = 0,1.

Bit	Description
[7] TEN	Transmit Enable This bit enables or disables the transmitter. The enable is also controlled by the $\overline{\text{CTS}}$ signal and the CTSE bit. If the $\overline{\text{CTS}}$ signal is Low and the CTSE bit is 1, the transmitter is enabled. 0: Transmitter disabled. 1: Transmitter enabled.
[6] REN	Receive Enable This bit enables or disables the receiver. 0: Receiver disabled. 1: Receiver enabled.
[5] CTSE	Clear To Send Enable 0: The $\overline{\text{CTS}}$ signal has no effect on the transmitter. 1: The UART-LDD recognizes the $\overline{\text{CTS}}$ signal as an enable control for the transmitter.
[4] PEN	Parity Enable This bit enables or disables parity and should be cleared for DALI (MSEL=100) and DMX (MSEL=101) modes. Even or odd is determined by the PSEL bit. 0: Parity is disabled. This bit is overridden by the MPEN bit. 1: The transmitter sends data with an additional parity bit and the receiver receives an additional parity bit.
[3] PSEL	Parity Select 0: Even parity is sent as an additional parity bit for the transmitter/receiver. 1: Odd parity is sent as an additional parity bit for the transmitter/receiver.

Bit	Description (Continued)
[2] SBRK	<p>Send Break</p> <p>This bit pauses or breaks data transmission. Sending a break interrupts any transmission in progress, so ensure that the transmitter has completed sending data before setting this bit. In standard UART Mode, the duration of the break is determined by how long the software leaves this bit asserted. Also the duration of any required stop bits following the break must be timed by software before writing a new byte to be transmitted to the Transmit Data Register. In LIN Mode, the master sends a break character by asserting SBRK. The duration of the break is timed by hardware and the SBRK bit is deasserted by hardware when the break is completed. The duration of the break is determined by the TxBreakLength field of the LIN Control Register. One or two stop bits are automatically provided by the hardware in LIN Mode, as defined by the stop bit.</p> <p>In DALI Mode and DMX Mode, this bit pauses or breaks data transmission just as in standard UART Mode. In DMX Mode, hardware can time the duration of the break if AUTOBRK is set in the DMX Control Register.</p> <p>0: No break is sent. 1: A break is sent (the output of the transmitter is 0).</p>
[1] STOP	<p>Stop Bit Select</p> <p>0: The transmitter sends one stop bit. The receiver framing error check expects one stop bit. 1: The transmitter sends two stop bits. The receiver framing error check expects two stop bits.</p>
[0] LBEN	<p>Loop Back Enable</p> <p>0: Normal operation. 1: All transmitted data is looped back to the receiver.</p>

13.3.6. UART-LDD 0–1 Control 1 Registers

Multiple registers are accessible by a single bus address. The register selected is determined by the Mode Select (MSEL) field. These registers provide additional control over UART-LDD operation.

13.3.6.1. Multiprocessor Control Registers

When MSEL=000b, the Multiprocessor Control 0–1 registers, shown in Table 130, provide control for UART Multiprocessor Mode and Baud Rate Timer Mode, as well as other features that can apply to multiple modes.

Table 130. Multiprocessor Control 0–1 Registers (UxCTL1 with MSEL=000b)

Bit	7	6	5	4	3	2	1	0
Field	MPMD1	MPEN	MPMD0	MPBT	DEPOL	BRGCTL	RDAIRQ	Reserved
Reset	0	0	0	0	0	0	0	0
R/W	R/W	R/W	R/W	R/W	R/W	R/W	R/W	R
Address	U0CTL1 @ F43h, U1CTL1 @ F4Bh							

Note: R=read; R/W=read/write; x = 0,1.

Bit	Description
[7,5] MPMD[1:0]	<p>Multiprocessor (9-Bit) Mode</p> <p>00: The UART-LDD generates an interrupt request on all data and address bytes. 01: The UART-LDD generates an interrupt request only on received address bytes. 10: The UART-LDD generates an interrupt request when a received address byte matches the value stored in the Address Compare Register and on all successive data bytes until an address mismatch occurs. 11: The UART-LDD generates an interrupt request on all received data bytes for which the most recent address byte matched the value in the Address Compare Register.</p>
[6] MPEN	<p>Multiprocessor Enable</p> <p>This bit is used to enable Multiprocessor (9-bit) Mode. 0: Disable Multiprocessor (9-bit) Mode. 1: Enable Multiprocessor (9-bit) Mode.</p>
[4] MPBT	<p>Multiprocessor Bit Transmit</p> <p>This bit is applicable only when Multiprocessor (9-bit) Mode is enabled. 0: Send a 0 in the multiprocessor bit location of the data stream (9th bit). 1: Send a 1 in the multiprocessor bit location of the data stream (9th bit).</p>
[3] DEPOL	<p>Driver Enable Polarity</p> <p>0: DE signal is active High. 1: DE signal is active Low.</p>

Bit	Description (Continued)
[2] BRGCTL	<p>Baud Rate Generator Control</p> <p>This bit causes different UART-LDD behavior depending on whether the UART-LDD receiver is enabled (REN=1 in the UART-LDD Control 0 Register). When the UART-LDD receiver is not enabled, this bit determines whether the Baud Rate Generator issues interrupts. When the UART-LDD receiver is enabled, this bit allows Reads from the baud rate registers to return the BRG count value instead of the reload value.</p> <p>When the UART-LDD receiver is not enabled:</p> <ul style="list-style-type: none"> 0: BRG is disabled. Reads from the Baud Rate High and Low Byte registers return the BRG reload value. 1: BRG is enabled and counting. The Baud Rate Generator generates a receive interrupt when it counts down to 0. Reads from the Baud Rate High and Low Byte registers return the current BRG count value. <p>When the UART-LDD receiver is enabled:</p> <ul style="list-style-type: none"> 0: Reads from the Baud Rate High and Low Byte registers return the BRG reload value. 1: Reads from the Baud Rate High and Low Byte registers return the current BRG count value. Unlike the timers, there is no mechanism to latch the High Byte when the Low Byte is read.
[1] RDAIRQ	<p>Receive Data Interrupt</p> <ul style="list-style-type: none"> 0: Received data and receiver errors generates an interrupt request to the Interrupt controller. Note that RDAIRQ also affects DALI and DMX modes. In DMX Mode, the received data interrupts are governed by DMXSIRQ. 1: Received data does not generate an interrupt request to the Interrupt controller. Only receiver errors generate an interrupt request.
[0]	<p>Reserved</p> <p>This bit is reserved and must be programmed to 0.</p>

13.3.7. Noise Filter Control Registers

When MSEL=001b, the Noise Filter Control 0–1 registers, shown in Table 131, provide control for the digital noise filter.

Table 131. Noise Filter Control 0–1 Registers (UxCTL1 with MSEL=001b)

Bit	7	6	5	4	3	2	1	0
Field	NFEN	NFCTL			Reserved			
Reset	0	0	0	0	0	0	0	0
R/W	R/W	R/W	R/W	R/W	R	R	R	R
Address	U0CTL1 @ F43h, U1CTL1 @ F4Bh							

Note: R=read; R/W=read/write; x = 0,1.

Bit	Description
[7] NFEN	Noise Filter Enable 0: Noise filter is disabled. 1: Noise filter is enabled. Receive data is preprocessed by the noise filter.
[6:4] NFCTL	Noise Filter Control This field controls the delay and noise rejection characteristics of the noise filter. The wider the counter is, the more delay is introduced by the filter and the wider the noise event is filtered. 000: 4-bit up/down counter. 001: 5-bit up/down counter. 010: 6-bit up/down counter. 011: 7-bit up/down counter. 100: 8-bit up/down counter. 101: 9-bit up/down counter. 110: 10-bit up/down counter. 111: 11-bit up/down counter.
[3:0]	Reserved These bits are reserved and must be programmed to 0000.

13.3.8. LIN Control Registers

When MSEL=010b, the LIN Control 0–1 registers provide control for the LIN Mode of operation.

Table 132. LIN Control 0–1 Registers (UxCTL1 with MSEL=010b)

Bit	7	6	5	4	3	2	1	0
Field	LMST	LSLV	ABEN	ABIEN	LinState[1:0]		TxBreakLength	
Reset	0	0	0	0	0	0	0	0
R/W	R/W	R/W	R/W	R/W	R/W	R/W	R/W	R/W
Address	U0CTL1 @ F43h, U1CTL1 @ F4Bh							

Note: R/W=read/write; x = 0,1.

Bit	Description
[7] LMST	LIN Master Mode 0: LIN Master Mode not selected. 1: LIN Master Mode selected (if MPEN, PEN, LSLV=0).
[6] LSLV	LIN Slave Mode 0: LIN Slave Mode not selected. 1: LIN Slave Mode selected (if MPEN, PEN, LMST=0).
[5] ABEN	Autobaud Enable 0: Autobaud not enabled. 1: Autobaud enabled, if in LIN Slave Mode.
[4] ABIEN	Autobaud Interrupt Enable 0: Interrupt following autobaud does not occur. 1: Interrupt following autobaud enabled, if in LIN Slave Mode. When the autobaud character is received, a receive interrupt is generated and the ATB bit is set in the Status0 Register.
[3:2] LINSTATE[1:0]	LIN State Machine The LinState is controlled by both hardware and software. Software can force a state change at any time if necessary. In normal operation, software moves the state in and out of Sleep state. For a LIN slave, software changes the state from Sleep to Wait for Break, after which hardware cycles through the Wait for Break, Autobaud and Active states. Software changes the state from one of the active states to Sleep state, if the LIN bus goes into Sleep Mode. For a LIN master, software changes the state from Sleep to Active, where it remains until the software sets it back to the Sleep state. After configuration, software does not alter the LinState field during operation. 00: Sleep state (either LMST or LSLV can be set). 01: Wait for Break state (only valid for LSLV=1). 10: Autobaud state (only valid for LSLV=1). 11: Active state (either LMST or LSLV can be set).

Bit	Description (Continued)
[1:0]	TxBreakLength
TxBreakLength	Used in LIN Mode by the master to control the duration of the transmitted break. 00: 13 bit times. 01: 14 bit times. 10: 15 bit times. 11: 16 bit times.

13.3.9. DALI Control Registers

The DALI Control 0–1 registers (UxCTL1), shown in Table 133, provide control for the DALI Mode of operation.

Table 133. DALI Control 0–1 Registers (UxCTL1 with MSEL=100b)

Bit	7	6	5	4	3	2	1	0
Field	MULTTXE	MULTRXE	BPEN	BPENC	STRTPOL	BITORD	CLSNE	PARTRXE
Reset	0	0	0	0	0	0	0	0
R/W	R/W	R/W	R/W	R/W	R/W	R/W	R/W	R/W
Address	U0CTL1 @ F43h, U1CTL1 @ F4Bh							

Note: R/W=read/write; x = 0,1.

Bit	Description
[7] MULTTXE	Multiple-Byte Transmit Enable TEN in the UART-LDD Control Register must also be set to enable transmit. 0: Transmit stop bit(s) after each byte transmitted. 1: Transmit multiple bytes without stop bit(s) inserted between the bytes as long as data is available in the UART-LDD Transmit Data Register. Stop bit(s) are transmitted after the last byte is transmitted.
[6] MULTRXE	Multiple-Byte Receive Enable REN in the UART-LDD Control Register must also be set to enable receive. 0: Stop bit(s) are expected after each byte received. 1: Multiple bytes can be received without stop bit(s) inserted between the bytes.
[5] BPEN	Biphase Encoding Enable 0: Biphase encoding not enabled. 1: Biphase encoding enabled. BPEN should be set for DALI operation.
[4] BPENC	Biphase Encoding BPENC has an effect only if BPEN=1. 0: DALI biphase encoding. Logic 0 is encoded as biphase 1→0 and logic 1 is encoded as biphase 0→1. 1: Alternate biphase encoding. Logic 0 is encoded as biphase 0→1 and logic 1 is encoded as biphase 1→0.

Bit	Description (Continued)
[3] STRTPOL	Start Bit Polarity 0: Start bit is a logic 0. 1: Start bit is a logic 1. STRTPOL is typically set for DALI.
[2] BITORD	Bit Order 0: Standard UART bit order with the LSB (TxD[0]/RxD[0]) transmitted/received first. 1: DALI bit order with the MSB (TxD[7]/RxD[7]) transmitted/received first.
[1] CLSNE	Collision Detection Enable 0: Collision detection is disabled. 1: Collision detection is enabled. CLSNE should be set only for DALI master transmissions. If a collision occurs while CLSNE is set, CLSN will be set in the UART-LDD Status Register and an interrupt will be generated.
[0] PARTRXE	Partial Byte Reception Enable PARTRXE has an effect only when receiving. 0: Partial bytes are not loaded into RXDATA. 1: Partial bytes are loaded into RXDATA if a partial byte has been received upon receiving a stop bit.

13.3.10. DMX Control Registers

When MSEL=101b, the DMX Control 0–1 registers, shown in Table 134, provide control for the DMX Mode of operation.

Table 134. DMX Control 0-1 Registers (UxCTL1 with MSEL=101b)

Bit	7	6	5	4	3	2	1	0
Field	DMXMST	DMXSLV	DMXSIRQ		Reserved	AUTOBRK	WFBRK	COMP_ADDR[8]
Reset	0	0	0	0	0	0	0	0
R/W	R/W	R/W	R/W	R/W	R	R/W	R/W	R/W
Address	U0CTL1 @ F43h, U1CTL1 @ F4Bh							

Note: R/W=read/write; x = 0,1.

Bit	Description
[7] DMXMST	DMX Master Mode 0: DMX Master Mode not selected. 1: DMX Master Mode selected.
[6] DMXSLV	DMX Slave Mode 0: DMX Slave Mode not selected. 1: DMX Slave Mode selected.

Bit	Description (Continued)
[5:4] DMXSIRQ	<p>DMX Slave Interrupt Control</p> <p>DMXSIRQ has an effect only for a DMX slave (DMXSLV=1) and if both RDAIRQ=1 and WFBRK=0.</p> <p>00: Interrupt following each received byte.</p> <p>01: Interrupt following each received byte in a slot \geq the slave address only if the first received byte was the null start.</p> <p>10: Interrupt following the start code.</p> <p>11: Interrupt following the start code and each received byte in a slot \geq the slave address only if the first received byte was the null start.</p>
[3]	<p>Reserved</p> <p>This bit is reserved and must be programmed to 0.</p>
[2] AUTOBRK	<p>Automatic Break</p> <p>AUTOBRK has an effect only for a DMX Master (DMXMST=1).</p> <p>0: No automatic break transmission. Manually send a break using SBRK</p> <p>1: Automatic break transmission of 24 bit times (96us at 250kHz) upon being set. AUTOBRK is cleared by hardware upon completing the break transmission. Clearing AUTOBRK during a break transmission does not terminate the break transmission.</p>
[1] WFBRK	<p>Wait for Break</p> <p>WFBRK has an effect only for a DMX slave (DMXSLV=1).</p> <p>0: Do not wait for break. Continue to generate receive data interrupts as configured by DMXSIRQ and RDAIRQ.</p> <p>1: Wait for break. Do not generate received data interrupts until the next break is received. Upon receiving a break, WFBRK is cleared by hardware.</p>
[0] COMP_AD DR[8]	<p>Comparison Address bit 8</p> <p>COMP_ADDR[8] has an effect only for a DMX slave (MODE=101, DMXSLV=1).</p> <p>0–1: Combined with COMP_ADDR[7:0] in UART-LDD Address Compare Register to form a 9-bit comparison address. For a DMX slave, the comparison address is compared against the received data slot number.</p>

13.3.11. UART-LDD Address Compare Registers

The UART-LDD Address Compare 0–1 registers, shown in Table 135, store the multinode network address of the UART-LDD. When the MPMD[1] bit of the UART-LDD Multiprocessor Control Register is set, all incoming address bytes are compared to the value stored in this Address Compare Register. Receive interrupts and RDA assertions only occur in the event of a match.

In the DMX Control Register, when DMXSLV and RDAIRQ are set and DMXSIRQ = x1, the data slot number is compared to the value of COMP_ADDR is stored in this address compare register and in the DMX Control Register. Interrupts can be configured to occur upon receiving characters in data slots equal to or greater than the COMP_ADDR value.

Table 135. UART-LDD 0–1 Address Compare Registers (UxADDR)

Bit	7	6	5	4	3	2	1	0
Field	COMP_ADDR							
Reset	0	0	0	0	0	0	0	0
R/W	R/W	R/W	R/W	R/W	R/W	R/W	R/W	R/W
Address	U0ADDR @ F45h, U1ADDR @ F4Dh							

Note: R/W=read/write; x = 0,1.

Bit	Description
[7:0] COMP_ADDR	Compare Address This 8-bit value is compared to the incoming address bytes. For DMX slaves, a 9th bit, COMP_ADDR[8] in the DMX Control Register is also used.

13.3.12. UART-LDD 0–1 Baud Rate High and Low Byte Registers

The UART-LDD 0–1 Baud Rate High and Low Byte registers, shown in Tables 136 and 137, combine to create a 16-bit baud rate divisor value (BRG[15:0]) that sets the data transmission rate (baud rate) of the UART-LDD.

Table 136. UART-LDD 0-1 Baud Rate High Byte Registers (UxBRH)

Bit	7	6	5	4	3	2	1	0
Field	BRH							
Reset	1	1	1	1	1	1	1	1
R/W	R/W	R/W	R/W	R/W	R/W	R/W	R/W	R/W
Address	U0BRH @ F46h, U1BRH @ F4Eh							

Note: R/W=read/write; x = 0,1.

Bit	Description
[7:0] BRH	Baud Rate High These bits set the High byte of the baud rate divisor value.

Table 137. UART-LDD 0–1 Baud Rate Low Byte Registers (UxBRL)

Bit	7	6	5	4	3	2	1	0
Field	BRL							
Reset	1	1	1	1	1	1	1	1
R/W	R/W	R/W	R/W	R/W	R/W	R/W	R/W	R/W
Address	U0BRL @ F47h, U1BRL @ F4Fh							

Note: R/W=read/write; x = 0,1.

Bit	Description
[7:0] BRL	Baud Rate Low These bits set the Low Byte of the baud rate divisor value.

The UART-LDD data rate is calculated using the following equation for standard UART and DMX modes. For the LIN protocol, the Baud Rate registers must be programmed with the baud period rather than 1/16th of the baud period.

► **Note:** The UART must be disabled when updating the Baud Rate registers because the high and low registers must be written independently.

The UART-LDD data rate is calculated using the following equation for standard UART and DMX Mode operation:

$$\text{UART Data Rate (bits/s)} = \frac{\text{System Clock Frequency (Hz)}}{16 \times \text{UART Baud Rate Divisor Value}}$$

The UART-LDD data rate is calculated using the following equation for LIN Mode UART operation:

$$\text{UART Data Rate (bits/s)} = \frac{\text{System Clock Frequency (Hz)}}{\text{UART Baud Rate Divisor Value}}$$

The UART-LDD data rate is calculated using the following equation for DALI Mode operation:

$$\text{UART Data Rate (bits/s)} = \frac{\text{System Clock Frequency (Hz)}}{32 \times \text{UART Baud Rate Divisor Value}}$$

For a given UART-LDD data rate, the integer baud rate divisor value is calculated using the following equation for standard UART or DMX Mode operation:

$$\text{UART Baud Rate Divisor Value (BRG)} = \text{Round}\left(\frac{\text{System Clock Frequency (Hz)}}{16 \times \text{UART Data Rate (bits/s)}}\right)$$

For a given UART-LDD data rate, the integer baud rate divisor value is calculated using the following equation for LIN Mode UART operation:

$$\text{UART Baud Rate Divisor Value (BRG)} = \text{Round}\left(\frac{\text{System Clock Frequency (Hz)}}{\text{UART Data Rate (bits/s)}}\right)$$

For a given UART-LDD data rate, the integer baud rate divisor value is calculated using the following equation for DALI Mode operation:

$$\text{UART Baud Rate Divisor Value (BRG)} = \text{Round}\left(\frac{\text{System Clock Frequency (Hz)}}{32 \times \text{UART Data Rate (bits/s)}}\right)$$

The baud rate error relative to the appropriate baud rate is calculated using the following equation:

$$\text{UART Baud Rate Error (\%)} = 100 \times \left(\frac{\text{Actual Data Rate} - \text{Desired Data Rate}}{\text{Desired Data Rate}}\right)$$

For reliable communication, the UART-LDD baud rate error must never exceed 5 percent in standard UART modes. Tables 138 through 142 provide error data for popular baud rates and commonly-used crystal oscillator frequencies for standard UART and DMX modes of operation.

Table 138. UART-LDD Baud Rates, 20.0MHz System Clock

Applicable Rate (kHz)	BRG Divisor (Decimal)	Actual Rate (kHz)	Error (%)	Applicable Rate (kHz)	BRG Divisor (Decimal)	Actual Rate (kHz)	Error (%)
1250.0	1	1250.0	0.00	9.60	130	9.62	0.16
625.0	2	625.0	0.00	4.80	260	4.81	0.16
250.0	5	250.0	0.00	2.40	521	2.40	-0.03
115.2	11	113.64	-1.36	1.20	1042	1.20	-0.03
57.6	22	56.82	-1.36	0.60	2083	0.60	0.02
38.4	33	37.88	-1.36	0.30	4167	0.30	-0.01
19.2	65	19.23	0.16				

Table 139. UART-LDD Baud Rates, 19.99848MHz System Clock

Applicable Rate (kHz)	BRG Divisor (Decimal)	Actual Rate (kHz)	Error (%)	Applicable Rate (kHz)	BRG Divisor (Decimal)	Actual Rate (kHz)	Error (%)
1250.0	1	1250.0	-0.06	9.60	130	9.61	0.10
625.0	2	625.0	-0.06	4.80	260	4.81	0.10
250.0	5	250.0	-0.06	2.40	521	2.40	-0.09
115.2	11	113.6	-1.41	1.20	1042	1.20	0.01
57.6	22	56.79	-1.41	0.60	2083	0.60	0.01
38.4	33	37.86	-1.41	0.30	4167	0.30	0.01
19.2	65	19.2	0.10				

Table 140. UART-LDD Baud Rates, 10.0 MHz System Clock

Applicable Rate (kHz)	BRG Divisor (Decimal)	Actual Rate (kHz)	Error (%)	Applicable Rate (kHz)	BRG Divisor (Decimal)	Actual Rate (kHz)	Error (%)
1250.0	N/A	N/A	N/A	9.60	65	9.62	0.16
625.0	1	625.0	0.00	4.80	130	4.81	0.16
250.0	3	208.3	-16.67	2.40	260	2.40	0.16
115.2	5	125.0	8.51	1.20	521	1.20	-0.03
57.6	11	56.8	-1.36	0.60	1042	0.60	-0.03
38.4	16	39.1	1.73	0.30	2083	0.30	0.2
19.2	33	18.9	-1.36				

Table 141. UART-LDD Baud Rates, 7.3728MHz System Clock

Applicable Rate (kHz)	BRG Divisor (Decimal)	Actual Rate (kHz)	Error (%)	Applicable Rate (kHz)	BRG Divisor (Decimal)	Actual Rate (kHz)	Error (%)
1250.0	N/A	N/A	N/A	9.60	48	9.60	0.00
625.0	N/A	N/A	N/A	4.80	96	4.80	0.00
250.0	2	230.4	-7.84	2.40	192	2.40	0.00
115.2	4	115.2	0.00	1.20	384	1.20	0.00
57.6	8	57.6	0.00	0.60	768	0.60	0.00
38.4	12	38.4	0.00	0.30	1536	0.30	0.00
19.2	24	19.2	0.00				



Table 142. UART-LDD Baud Rates, 2.4576MHz System Clock

Applicable Rate (kHz)	BRG Divisor (Decimal)	Actual Rate (kHz)	Error (%)	Applicable Rate (kHz)	BRG Divisor (Decimal)	Actual Rate (kHz)	Error (%)
1250.0	N/A	N/A	N/A	9.60	16	9.60	0.00
625.0	N/A	N/A	N/A	4.80	32	4.80	0.00
250.0	N/A	N/A	N/A	2.40	64	2.40	0.00
115.2	N/A	N/A	N/A	1.20	128	1.20	0.00
57.6	3	57.6	-11.11	0.60	256	0.60	0.00
38.4	4	38.4	0.00	0.30	512	0.30	0.00
19.2	8	19.2	0.00				

Chapter 15. Enhanced Serial Peripheral Interface

The Enhanced Serial Peripheral Interface (ESPI) supports the Serial Peripheral Interface (SPI) and Inter-IC Sound (I²S). ESPI includes the following features:

- Full-duplex, synchronous, character-oriented communication
- Four-wire interface (\overline{SS} , SCK, MOSI and MISO)
- Transmit and receive buffer registers to enable high throughput
- Master Mode transfer rates up to a maximum of one-half the system clock frequency
- Slave Mode transfer rates up to a maximum of one-eighth the system clock frequency
- Error detection
- Dedicated Programmable Baud Rate Generator
- Data transfer control via polling, interrupt or DMA

15.1. Architecture

The ESPI is a full-duplex, synchronous, character-oriented channel that supports a four-wire interface (serial clock, transmit data, receive data and slave select). The ESPI block consists of a shift register, data buffer register, a baud rate (clock) generator, control/status registers and a control state machine. Transmit and receive transfers are in synch because there is a single shift register for both transmitting and receiving data. Figure 37 shows a diagram of the ESPI block.

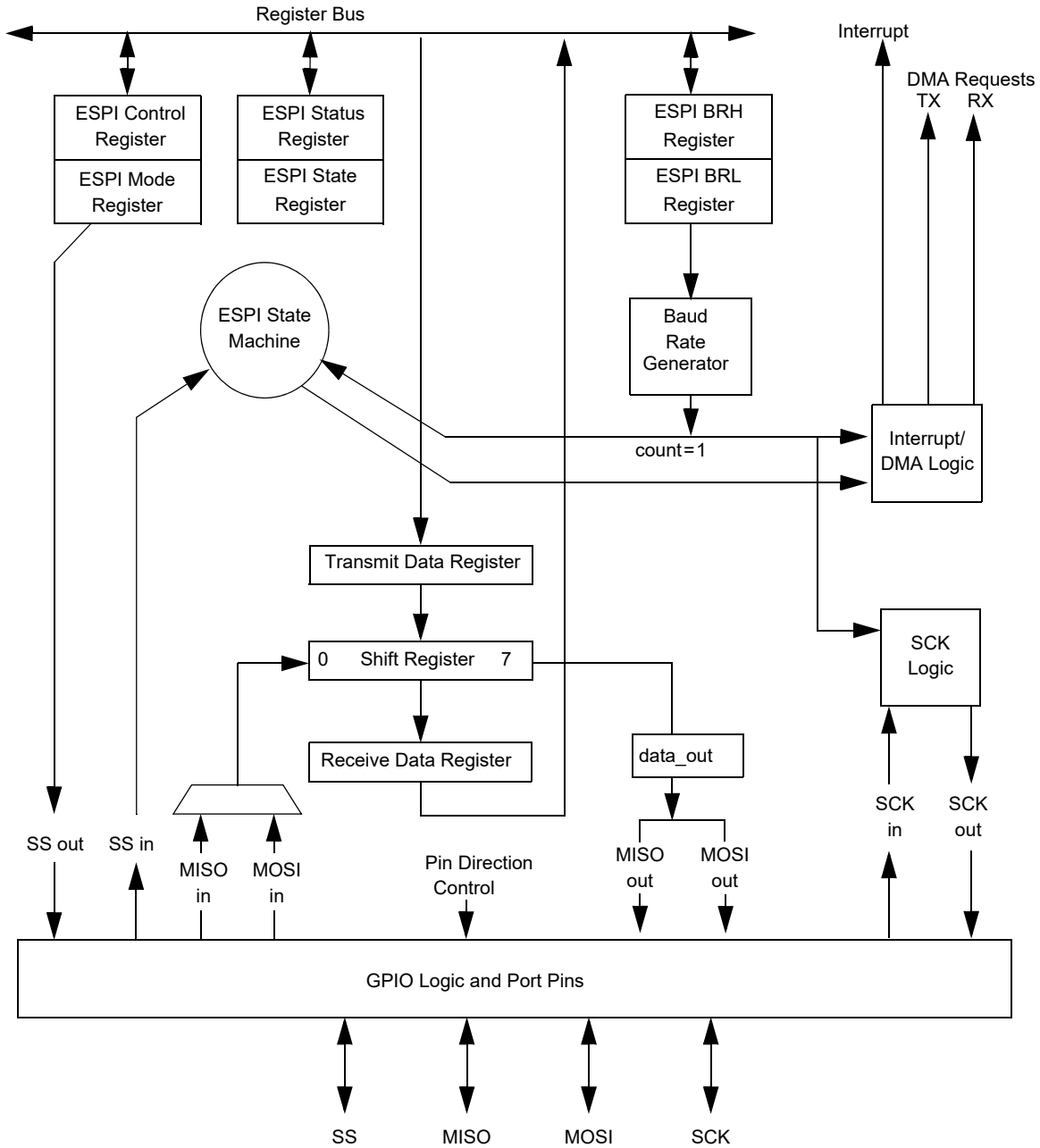

Figure 37. ESPI Block Diagram

15.2. ESPI Signals

The four ESPI signals are:

- Master-In/Slave-Out (MISO)
- Master-Out/Slave-In (MOSI)
- Serial Clock (SCK)
- Slave Select (\overline{SS})

The following paragraphs discuss these signals as they operate in both Master and Slave modes.

15.2.1. Master-In/Slave-Out

The Master-In/Slave-Out (MISO) pin is configured as an input in a master device and as an output in a slave device. Data is transferred most significant bit first. The MISO pin of a slave device is placed in a high-impedance state if the slave is not selected. When the ESPI is not enabled, this signal is in a high-impedance state. The direction of this pin is controlled by the MMEN bit of the ESPI Control Register.

15.2.2. Master-Out/Slave-In

The Master-Out/Slave-In (MOSI) pin is configured as an output in a master device and as an input in a slave device. Data is transferred most significant bit first. When the ESPI is not enabled, this signal is in a high-impedance state. The direction of this pin is controlled by the MMEN bit of the ESPI Control Register.

15.2.3. Serial Clock

The Serial Clock (SCK) synchronizes data movement both in and out of the Shift Register via the MOSI and MISO pins. In Master Mode (MMEN=1), the ESPI's Baud Rate Generator creates the serial clock and drives it out on its SCK pin to the slave devices. In Slave Mode, the SCK pin is an input. Slave devices ignore the SCK signal unless their \overline{SS} pin is asserted.

The master and slave are each capable of exchanging a character of data during a sequence of NUMBITS clock cycles; see the [ESPI 0-1 Mode Registers \(ESPIxMODE\)](#) on page 299 for details. In both master and slave ESPI devices, data is shifted on one edge of the SCK, and is sampled on the opposite edge where data is stable. SCK phase and polarity is determined by the PHASE and CLKPOL bits in the ESPI Control Register.

15.2.4. Slave Select

The Slave Select signal is a bidirectional framing signal with several modes of operation to support SPI and other synchronous serial interface protocols. Slave Select Mode is

selected by the SSMD field of the ESPI Mode Register. The direction of the \overline{SS} signal is controlled by the SSIO bit of the ESPI Mode Register. The \overline{SS} signal is an input on slave devices, and is an output on the active master device. Slave devices ignore transactions on the bus unless their Slave Select input is asserted. In SPI Master Mode, additional GPIO pins are required to provide Slave Selects if there is more than one slave device.

15.3. Operation

During a transfer, data is sent and received simultaneously by both the master and slave devices. Separate signals are required for transmit data, receive data, and the serial clock. When a transfer occurs, a multi-bit (typically 8-bit) character is shifted out one data pin, and a multi-bit character is simultaneously shifted in on second data pin. An 8-bit shift register in the master and an 8-bit shift register in the slave are connected as a circular buffer. The ESPI Shift Register is buffered to support back-to-back character transfers in high-performance applications.

Though the hardware is inherently full-duplex during an SPI transaction, software may choose to use the SPI to send only, to receive only, or to both send and receive data. The ESPIEN1 and ESPIEN0 bits in the Control Register are used to enable data movement in transmit and receive directions. Only the data interrupt(s) and DMA request(s) associated with the enabled direction(s) will be asserted. If transmit is enabled by ESPIEN1=1, then the TDRE bit in the status register can be set by the SPI and assert the SPI interrupt if DIRQS=1. If receive is enabled by ESPIEN0=1, then the RDRNE bit in the status register can be set by the SPI and will assert the SPI interrupt if DIRQS=1.

The TDRE and RDRNE bits, when set, also generate transmit and receive DMA requests. When using DMA to transfer data, set DIRQS=0 to prevent data interrupts from TDRE and RDRNE. In this case, error interrupts still occur and must be handled directly by the software.

When ESPIEN1=0 (transmit is disabled), transmit data will be all 1s and neither a transmit interrupt nor a DMA request will be asserted. When ESPIEN0=0 (receive is disabled), RDRNE will not be set; therefore, neither a receive interrupt nor a DMA request will be asserted. When both ESPIEN1 and ESPIEN0 are set in Master Mode following a character transfer, both interrupts or DMA requests must be serviced before the next transaction will start. These transmit and receive requests can be serviced in either order. To support back-to-back transfers without an intervening pause, the receive and transmit interrupts must be serviced while the current character is being transferred.

The master sources the Serial Clock (SCK) and Slave Select signal (\overline{SS}) during the transfer.

15.3.1. Throughput

In Master Mode, the maximum SCK rate supported is one-half the system clock frequency. This frequency is achieved by programming the value 0001h into the Baud Rate High/Low subregister pair. In SPI Master Mode, if the software (or DMA) transfers do not keep up with the SPI baud rate, there will be a pause between characters. In I²S Master Mode, the transfer will be terminated if new data is not available to send.

In Slave Mode, the transfer rate is controlled by the master. As long as the TDRE and RDRNE interrupt are serviced before the next character transfer completes, the slave will keep up with the master. The master's baud rate should be set for compatibility with all slave devices so that transmit underruns and receive overruns do not occur. In Slave Mode, the baud rate must be restricted to a maximum of one-eighth of the system clock frequency to allow for synchronization of the SCK input to the internal system clock.

15.3.2. ESPI Clock Phase and Polarity Control

The ESPI supports four combinations of serial clock phase and polarity using two bits in the ESPI Control Register. The clock polarity bit, CLKPOL, selects an active High or active Low clock, and has no effect on the transfer format. Table 143 lists the ESPI clock phase and polarity operation parameters. The clock phase bit, PHASE, selects one of two fundamentally different transfer formats. The data is output a half-cycle before the receive clock edge, which provides a half cycle of setup and hold time.

Table 143. ESPI Clock Phase (PHASE) and Clock Polarity (CLKPOL) Operation

PHASE	CLKPOL	SCK Transmit Edge	SCK Receive Edge	SCK Idle State
0	0	Falling	Rising	Low
0	1	Rising	Falling	High
1	0	Rising	Falling	Low
1	1	Falling	Rising	High

15.3.2.1. Transfer Format when Phase Equals Zero

Figure 38 shows a timing diagram for an SPI-type transfer, in which PHASE=0. For SPI transfers, the clock only toggles during a character transfer. The two SCK waveforms show polarity with CLKPOL=0 and CLKPOL=1. The diagram can be interpreted as either a master or slave timing diagram, because the SCK Master-In/Slave-Out (MISO) and Master-Out/Slave-In (MOSI) pins are directly connected between the master and the slave.

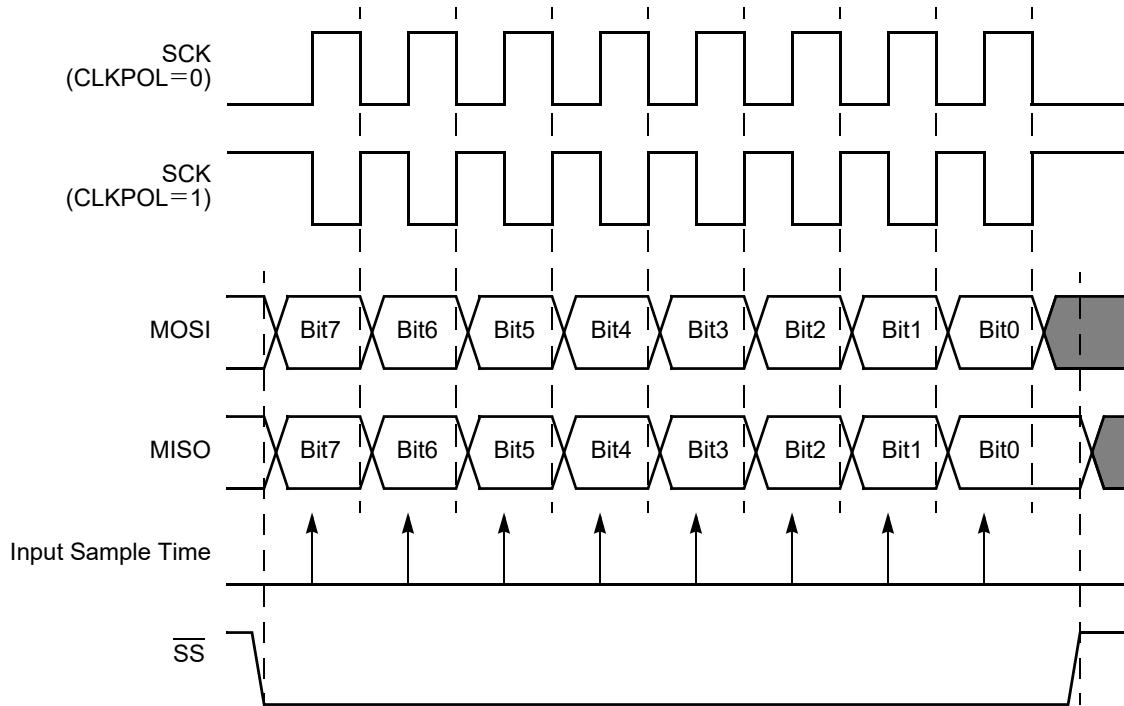

Figure 38. ESPI Timing when PHASE=0

15.3.2.2. Transfer Format When Phase Equals One

Figure 39 shows a timing diagram for an SPI-type transfer in which PHASE is 1. For SPI transfers, the clock only toggles during a character transfer. Two waveforms are depicted for SCK: one for CLKPOL=0 and another for CLKPOL=1.

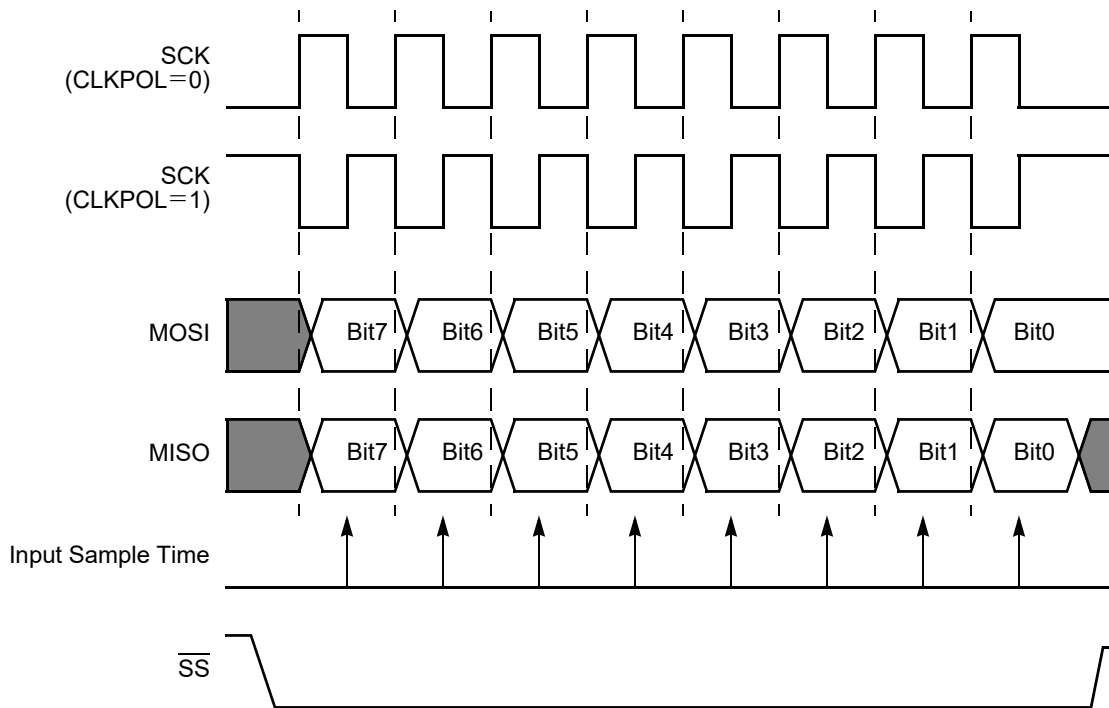

Figure 39. ESPI Timing when PHASE=1

15.3.3. Slave Select Modes of Operation

This section describes the different modes of data transfer supported by the ESPI block. The mode is selected by the Slave Select Mode (SSMD) field of the Mode Register.

15.3.3.1. SPI Mode

SPI Mode is selected by setting the SSMD field of the Mode Register to 000. In this mode, software controls the assertion of the \overline{SS} signal directly via the SSV and TEOF bits of the SPI Transmit Data Command Register. Software can be used to control an SPI Mode transaction. Prior to writing the first transmit data byte, software sets the SSV bit.

\overline{SS} will remain asserted when one or more characters are transferred. There are two mechanisms for deasserting \overline{SS} at the end of the transaction. One method used by software is to set the TEOF bit of the Transmit Data Command Register, when the last TDRE interrupt is being serviced (set TEOF before writing the last data byte). After the last bit of the last character is transmitted, the hardware will automatically deassert the SSV and TEOF bits. The second method is for software to directly clear the SSV bit after the transaction completes. If software clears the SSV bit directly it is not necessary for software to also set the TEOF bit on the last transmit byte. After writing the last transmit byte, the end of the

transaction can be detected by waiting for the last RDRNE interrupt or by monitoring the TFST bit in the ESPI Status Register.

Transmit underrun and receive overrun errors will not occur in an SPI Mode master. If the RDRNE and TDRE requests have not been serviced before the current byte transfer completes, SCK will be paused until the Data Register is read and written. The transmit underrun and receive overrun errors will occur in an SPI Mode slave if the slave’s software does not keep up with the master’s data rate. In this case, the shift register in the slave will be loaded with all 1s to serve as transmit data.

In SPI Mode, the SCK is active only for the data transfer, with one SCK period per bit transferred. If the SPI bus has multiple slaves, the Slave Select lines to all slaves – or all but one of the slaves – must be controlled independently by software using GPIO pins. Figure 40 shows a typical multiple character transfer in SPI Mode.

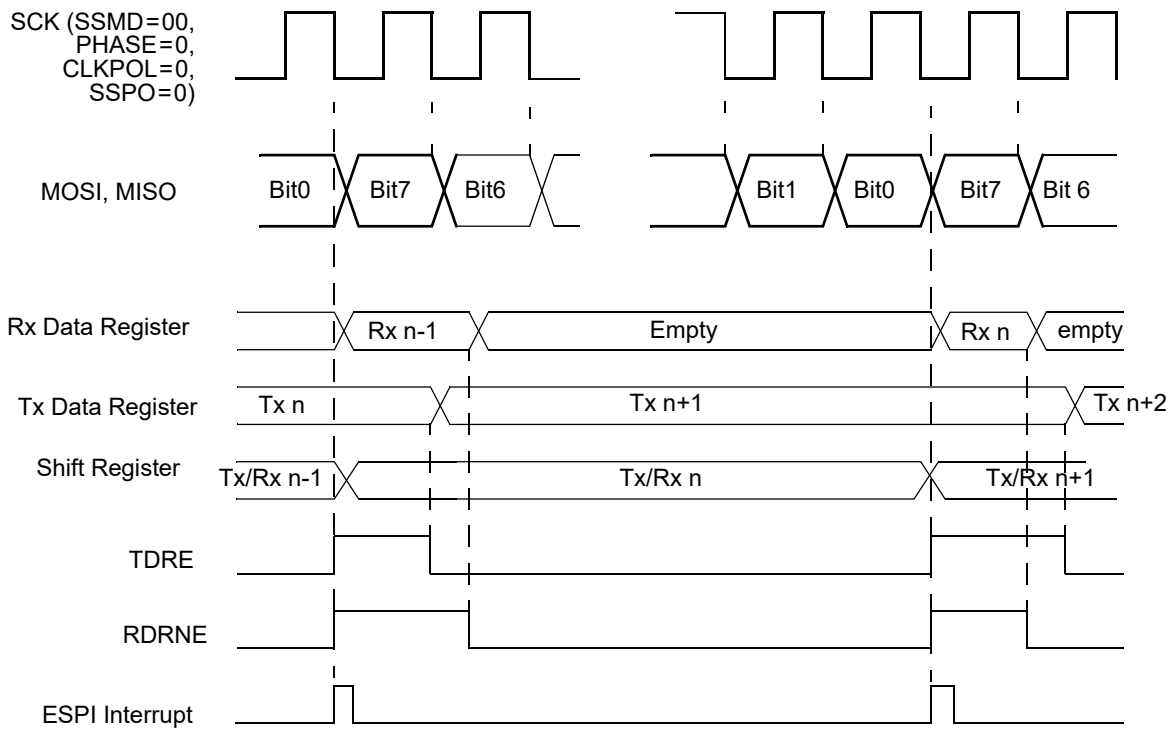

Figure 40. SPI Mode (SSMD=000)

► **Note:** When character n is transferred via the Shift Register, software responds to the receive request for character $n-1$ and the transmit request for character $n+1$.

15.3.3.2. Inter-IC Sound (I²S) Mode

This mode is selected by setting the SSMD field of the Mode Register to 010. The PHASE and CLKPOL bits of the Control Register must be cleared to 0 and the ESPIEN1 bit must be set=1 (ESPIEN0 can be either 1 or 0). If the ESPI is being used to both send and receive I²S data, the TDRE interrupt should be serviced before the RDRF interrupt. Figure 41 shows I²S Mode, with \overline{SS} alternating between consecutive frames. Each audio frame consists of a fixed number of bits, typically a multiple of 8 bits such as 16.

The SSV indicates whether the corresponding bytes are left or right channel data. The SSV value must be updated when servicing the TDRE interrupt/request for the first byte in a left or write channel frame. This update can be made by performing a byte write to update SSV, followed by a byte Write to the Data Register. The \overline{SS} signal will lead the data by one SCK period.

A DMA can be used to transfer audio data, but software must toggle the SSV bit in sync with the first data byte of each left/right channel word.

A transaction is terminated when the master has no more data to transmit. After the last bit is transferred, SCK will stop, and \overline{SS} and SSV will return to their default states. A transmit underrun error will occur at this point.

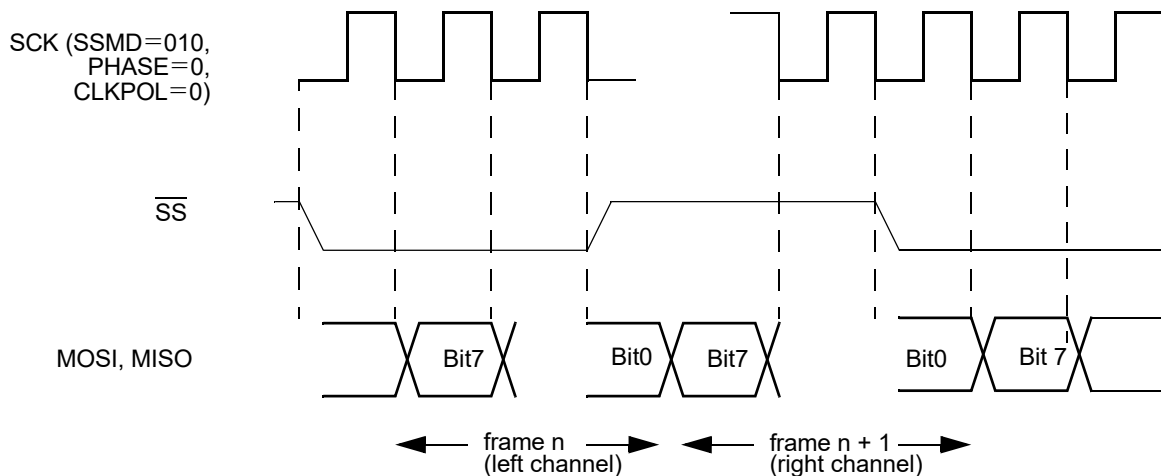

Figure 41. I²S Mode (SSMD=010), Multiple Frames

15.3.4. SPI Protocol Configuration

This section describes how to configure the ESPI block for the SPI protocol. In the SPI protocol, the master sources the SCK and asserts Slave Select signals to one or more slaves. The Slave Select signals are typically active Low.

15.3.4.1. SPI Master Operation

The ESPI block is configured for Master Mode operation by setting the MMEN bit=1 in the ESPICL Register. The SSMD field of the ESPI Mode Register is set to 000 for SPI Protocol Mode. The PHASE, CLKPOL and WOR bits in the ESPICL Register and the NUMBITS field in the ESPI Mode Register must be set to be consistent with the slave SPI devices. Typically, for an SPI master, SSIO=1 and SSPO=0.

The appropriate GPIO pins are configured for the ESPI alternate function on the MOSI, MISO and SCK pins. Typically, the GPIO for the ESPI \overline{SS} pin is configured in an alternate function mode, though the software can use any GPIO pin(s) to drive one or more slave select lines. If the ESPI \overline{SS} signal is not used to drive a Slave Select, the SSIO bit should still be set to 1 in a single-master system. Figures 42 and 43 show a block diagram of the the ESPI configured as an SPI master.

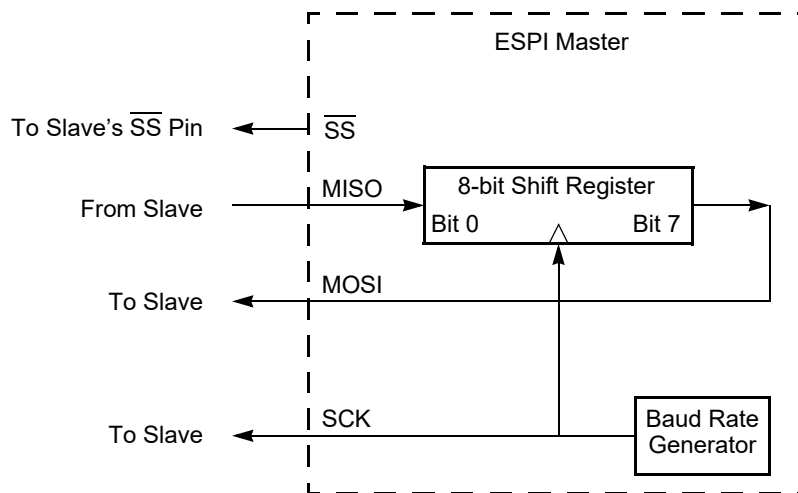

Figure 42. ESPI Configured as an SPI Master in a Single Master, Single Slave System

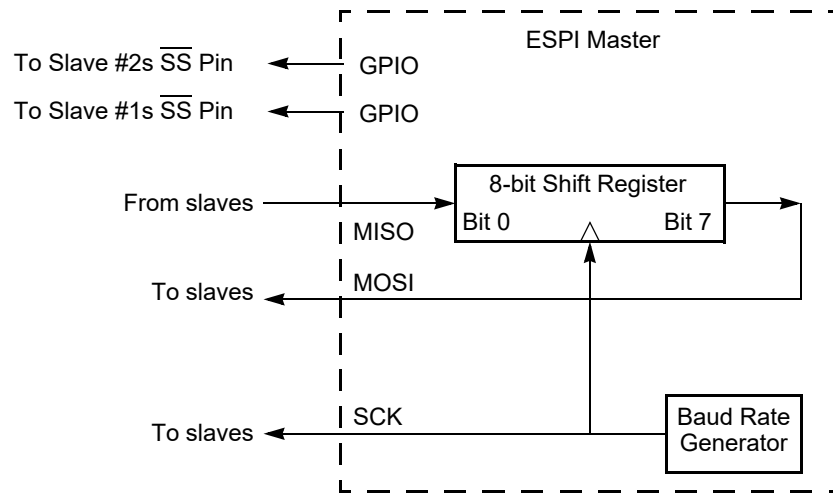

Figure 43. ESPI Configured as an SPI Master in a Single Master, Multiple Slave System

15.3.4.2. Multi-Master SPI Operation

In a multi-master SPI system, all SCK pins are tied together, all MOSI pins are tied together, and all MISO pins are tied together. All SPI pins must be configured in open-drain mode to prevent bus contention. At any time, only one SPI device can be configured as a master, and all other devices on the bus are configured as slaves. The master asserts the \overline{SS} pin on a selected slave. Next, the active master drives the clock and transmits data on the SCK and MOSI pins to the SCK and MOSI pins on the slave (including those slaves which are not enabled). The enabled slave drives data out its MISO pin to the MISO Master pin.

When the ESPI is configured as a master in a multi-master SPI system, the \overline{SS} pin must be configured as an input. The \overline{SS} input signal on a device configured as a master should remain High. If the \overline{SS} signal on the active master goes Low (indicating that another master is accessing this device as a slave), a collision error flag is set in the ESPI Status Register. The slave select outputs on a master in a multi-master system must come from GPIO pins.

15.3.4.3. SPI Slave Operation

The ESPI block is configured for Slave Mode operation by setting the MMEN bit=0 in the ESPICTL Register and setting the SSIO bit=0 in the ESPIMODE Register. The SSMD field of the ESPI Mode Register is set to 000 for SPI Protocol Mode. The PHASE, CLKPOL and WOR bits in the ESPICTL Register and the NUMBITS field in the ESPIMODE Register must be set to be consistent with the other SPI devices. Typically, for an SPI slave, SSPO=0.

If the slave has data to send to the master, the data must be written to the Transmit Data Register before the transaction starts (first edge of SCK when \overline{SS} is asserted). If the Transmit Data Register is not written prior to the slave transaction, the MISO pin outputs all ones.

Due to the delay resulting from synchronization of the \overline{SS} and SCK input signals to the internal system clock, the maximum SCK baud rate that can be supported in Slave Mode is the system clock frequency divided by 8. This rate is controlled by the SPI master. Figure 44 shows the ESPI configuration in SPI Slave Mode.

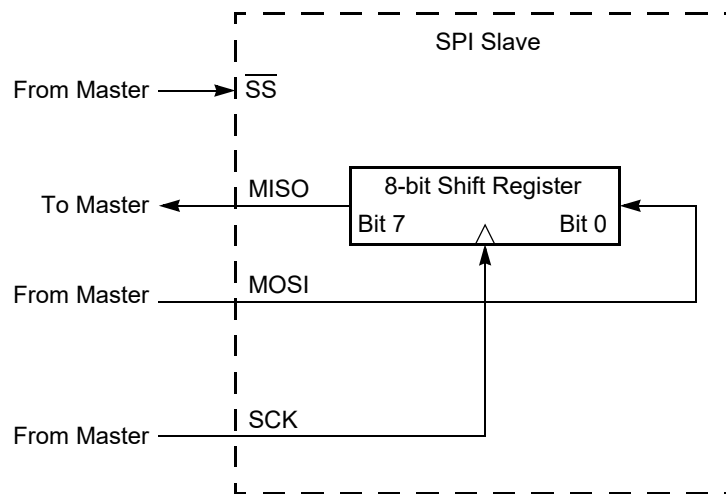

Figure 44. ESPI Configured as an SPI Slave

15.3.5. Error Detection

Error events detected by the ESPI block are described in this section. Error events generate an ESPI interrupt and set a bit in the ESPI Status Register. Read or write a 1 to clear the error bits of the ESPI Status Register.

15.3.5.1. Transmit Underrun

A transmit underrun error occurs for a master with SSMD=010 when a character transfer is completed and when TDRE=1. When a transmit underrun occurs in these modes, the transfer will be aborted (i.e., SCK will halt and SSV will be deasserted). For a master in SPI Mode (SSMD=000), a transmit underrun is not signaled, because SCK will pause and wait for the Transmit Data Register to be written.

In Slave Mode, a transmit underrun error occurs if TDRE=1 and ESPIEN1 = 1 (transmit is enabled) at the start of a transfer. When a transmit underrun occurs in Slave Mode, ESPI will transmit a character of all ones.

A transmit underrun sets the TUND bit in the ESPI Status Register to 1. Writing a 1 to TUND clears this error flag.

15.3.5.2. Mode Fault (Multi-Master Collision)

A mode fault indicates when more than one master is trying to communicate simultaneously (i.e., a multi-master collision) in SPI Mode. The mode fault is detected when the enabled master's \overline{SS} input pin is asserted. For this assertion to occur, the Control and Mode registers must be configured with MMEN=1, SSIO=0 (\overline{SS} is an input) and \overline{SS} input=0. A mode fault sets the COL bit in the ESPI Status Register to 1. Writing a 1 to COL clears this error flag.

15.3.5.3. Receive Overrun

A receive overrun error occurs when a transfer completes and the RDRNE bit is still set from the previous transfer. A receive overrun sets the ROVR bit in the ESPI Status Register to 1. Writing a 1 to ROVR clears this error flag. The Receive Data Register is not overwritten and will contain the data from the transfer which initially set the RDRNE bit. Subsequent received data is lost until the RDRNE bit is cleared.

In SPI Master Mode, a receive overrun will not occur. Instead, the SCK will be paused until software responds to the previous RDRNE/TDRE requests.

15.3.5.4. Slave Mode Abort

In Slave Mode, if the \overline{SS} pin deasserts before all bits in a character have been transferred, the transaction is aborted. When this condition occurs, the ABT bit is set in the ESPI Status Register. A slave abort error resets the slave control logic to idle state.

A slave abort error is also asserted in Slave Mode if BRGCTL=1 and a baud rate generator time-out occurs. When BRGCTL=1 in Slave Mode, the baud rate generator functions as a watchdog timer monitoring the SCK signal. The BRG counter is reloaded every time a transition on SCK occurs while \overline{SS} is asserted. The Baud Rate Reload registers must be programmed with a value longer than the expected time between the \overline{SS} assertion and the first SCK edge, between SCK transitions while \overline{SS} is asserted, and between the last SCK edge and \overline{SS} deassertion. A time-out indicates that the master is stalled or disabled. Writing a 1 to ABT clears this error flag.

15.3.6. ESPI Interrupts

ESPI has a single interrupt output which is asserted when any of the TDRE, TUND, COL, ABT, ROVR or RDRNE bits are set in the ESPI Status Register. The setting of TDRE will only generate an interrupt if transmit is enabled (ESPIEN1 = 1). The interrupt is a pulse which is generated when any one of the source bits initially sets. The TDRE and RDRNE interrupts can be enabled/disabled via the Data Interrupt Request Select (DIRQS) bit of the ESPI Control Register.

A transmit interrupt is asserted by the TDRE status bit when the ESPI block is enabled and the DIRQS bit is set. The TDRE bit in the status register is cleared automatically when the

Transmit Data Register is written or the ESPI block is disabled. After the Transmit Data Register is loaded into the Shift Register to start a new transfer, the TDRE bit will be set again, causing a new transmit interrupt. In Master or Slave modes, if information is being received but not transmitted, the transmit interrupts can be eliminated by selecting Receive Only Mode (ESPIEN1,0=01).

A receive interrupt is generated by the RDRNE status bit when the ESPI block is enabled, the DIRQS bit is set, and a character transfer completes. At the end of the character transfer, the contents of the Shift Register are transferred into the Receive Data Register, causing the RDRNE bit to assert. The RDRNE bit is cleared when the Data Buffer is read as empty. If information is being transmitted but not received by the software application, the receive interrupt can be eliminated by selecting Transmit Only Mode (ESPIEN1,0=10) in either Master or Slave modes. When information is being sent and received under interrupt control, RDRNE and TDRE will both assert simultaneously at the end of a character transfer. In this case, RDRNE and TDRE can be serviced in either order.

ESPI error interrupts occur if any of the TUND, COL, ABT and ROVR bits in the ESPI Status Register are set. These bits are cleared by writing a 1. If the ESPI is disabled (ESPIEN1,0=00), an ESPI interrupt can be generated by a Baud Rate Generator time-out. This timer function must be enabled by setting the BRGCTL bit in the ESPICTL Register. This timer interrupt does not set any of the bits of the ESPI Status Register.

15.3.7. ESPI and DMA

The ESPI will assert a DMA RX request whenever the receive data register is not empty (RDRNE=1), and will deassert a DMA RX request whenever the Receive Data Register is read by the DMA or software.

The ESPI will assert a DMA TX request whenever the Transmit Data Register is empty (TDRE=1), and will deassert a DMA TX request whenever the Transmit Data Register is written by the DMA or software.

When using DMA, it can be desirable to clear DIRQS so that interrupts occur on errors, but not upon data requests. If the software application is moving data in only one direction, the ESPIEN1,ESPIEN0 bits are set to 10 or 01, allowing a single DMA channel to control the ESPI data transfer. When operating in Receive Only Mode, transmit data will be all 1s.

15.3.8. ESPI Baud Rate Generator

In ESPI Master Mode, the Baud Rate Generator creates a lower frequency serial clock (SCK) for data transmission synchronization between the master and the external slave. The input to the Baud Rate Generator is the system clock. The ESPI Baud Rate High and Low Byte registers combine to form a 16-bit reload value, BRG[15:0], for the ESPI Baud Rate Generator. The ESPI baud rate is calculated using the following equation:

$$\text{SPI Baud Rate (bits/s)} = \frac{\text{System Clock Frequency (Hz)}}{2 \times \text{BRG}[15:0]}$$

The minimum baud rate is obtained by setting BRG[15:0] to 0000h for a clock divisor value of (2 x 65536=131072).

When the ESPI is disabled, the Baud Rate Generator can function as a basic 16-bit timer with interrupt on time-out. Observe the following steps to configure the Baud Rate Generator as a timer with interrupt on time-out:

1. Disable the ESPI by clearing the ESPIEN1,0 bits in the ESPI Control Register.
2. Load the appropriate 16-bit count value into the ESPI Baud Rate High and Low Byte registers.
3. Enable the Baud Rate Generator timer function and associated interrupt by setting the BRGCTL bit in the ESPI Control Register to 1.

When configured as a general-purpose timer, the SPI BRG interrupt interval is calculated using the following equation:

$$\text{SPI BRG Interrupt Interval (s)} = \text{System Clock Period (s)} \times \text{BRG}[15:0]$$

15.4. ESPI Control Register Definitions

The ESPI control registers are defined in this section.

15.4.1. ESPI 0-1 Data Registers

The ESPI 0-1 Data Registers, shown in Table 144, address both the outgoing Transmit Data Registers and the incoming Receive Data Registers. Reads from an ESPI Data Register return the contents of the Receive Data Register. The Receive Data Register is updated with the contents of the Shift Register at the end of each transfer. Writes to an ESPI Data Register load the Transmit Data Register unless TDRE=0. Data is shifted out starting with bit 7. The last bit received resides in bit position 0. In either the Master or Slave modes, if TDRE=0, writes to this register are ignored.

When the character length is less than 8 bits (as set by the NUMBITS field in the ESPI Mode Register), the transmit character must be left-justified in the ESPI Data Register. A received character of less than 8 bits is right-justified (i.e., the last bit received is in bit position 0). For example, if the ESPI is configured for 4-bit characters, the transmit characters must be written to ESPIDATA[7:4] and the received characters are read from ESPIDATA[3:0].

Table 144. ESPI 0-1 Data Registers (ESPIxDATA)

Bit	7	6	5	4	3	2	1	0
Field	DATA							
Reset	X	X	X	X	X	X	X	X
R/W	R/W	R/W	R/W	R/W	R/W	R/W	R/W	R/W
Address	ESPI0DATA @ F60h, ESPI1DATA @ F68h							

Note: x references bits in the range [1:0].

Bit	Description
[7:0] DATA	Data Transmit and/or receive data. Writes to the ESPIDATA Register load the Shift Register. Reads from the ESPIDATA Register return the value of the Receive Data Register.

15.4.2. ESPI 0-1 Transmit Data Command Registers

The ESPI 0-1 Transmit Data Command Registers, shown in Table 145, provide control of the \overline{SS} pin when it is configured as an output (Master Mode).

Table 145. ESPI 0-1 Transmit Data Command Registers (ESPIxTDCR)

Bit	7	6	5	4	3	2	1	0
Field	Reserved						TEOF	SSV
Reset	0	0	0	0	0	0	0	0
R/W	R	R	R	R	R	R	R/W	R/W
Address	ESPI0TDCR @ F61h, ESPI1TDCR @ F69h							

Note: x references bits in the range [1:0].

Bit	Description
[7:2]	These bits are reserved and must be written to 000000.
[1] TEOF	Transmit End of Frame This bit is used in Master Mode to indicate that the data in the Transmit Data Register is the last byte of the transfer or frame. When the last byte has been sent \overline{SS} (and SSV) will change state, and TEOF will automatically clear. 0: The data in the Transmit Data Register is not the last character in the message. 1: The data in the Transmit Data Register is the last character in the message.
[0] SSV	Slave Select Value When SSIO=1, writes to this register will control the value output on the \overline{SS} pin. To learn more, see the SSMD field of the ESPI 0-1 Mode Registers section on page 299.

15.4.3. ESPI 0-1 Control Registers

The ESPI 0-1 Control Registers, shown in Table 146, configure the ESPI for transmit and receive operations.

Table 146. ESPI 0-1 Control Registers (ESPIxCTL)

Bit	7	6	5	4	3	2	1	0
Field	DIRQS	ESPIEN1	BRGCTL	PHASE	CLKPOL	WOR	MMEN	ESPIEN0
Reset	0	0	0	0	0	0	0	0
R/W	R/W	R/W	R/W	R/W	R/W	R/W	R/W	R/W
Address	ESPI0CTL @ F62h, ESPI1CTL @ F6Ah							

Note: x references bits in the range [1:0].

Bit	Description
[7]	Data Interrupt Request Select
DIRQS	This bit is used to disable or enable data (TDRE and RDRNE) interrupts. Disabling the data interrupts is required to control data transfer by polling or DMA. Error interrupts are not disabled. To block all ESPI interrupt sources, clear the ESPI interrupt enable bit in the Interrupt Controller. 0: TDRE and RDRNE assertions do not cause an interrupt. Use this setting if controlling data transfer by software polling of TDRE and RDRNE or by DMA. The TUND, COL, ABT and ROVR bits will cause an interrupt. 1: TDRE and RDRNE assertions will cause an interrupt. TUND, COL, ABT and ROVR will also cause interrupts. Use this setting when controlling data transfer via interrupt handlers.
[6,0]	ESPI Enable and Direction Control
ESPIEN1, ESPIEN0	00: The ESPI block is disabled. BRG can be used as a general-purpose timer by setting BRGCTL=1. 01: Receive Only Mode. Use this setting in Master or Slave Mode if software application is receiving data but not sending. Transmit interrupt and SPI TX DMA requests will not be asserted due to TDRE being set. Transmitted data will be all ones. Receive Only Mode for a master is not valid for I ² S operation (SSMD=010). 10: Transmit Only Mode Use this setting in Master or Slave Mode when the software application is sending data but not receiving. RDRNE will not assert. Receive interrupt and SPI RX DMA requests will not be asserted. 11: Transmit/Receive Mode Use this setting if the software application is both sending and receiving information. Both TDRE and RDRNE will be active.

Bit	Description (Continued)
[5] BRGCTL	<p>Baud Rate Generator Control</p> <p>The function of this bit depends upon ESPIEN1,0. When ESPIEN1,0=00, this bit allows enabling the BRG to provide periodic interrupts.</p> <p>If the ESPI is disabled</p> <p>0: The Baud Rate Generator timer function is disabled. Reading the Baud Rate High and Low registers returns the BRG reload value.</p> <p>1: The Baud Rate Generator timer function and time-out interrupt is enabled. Reading the Baud Rate High and Low registers returns the BRG Counter value.</p> <p>If the ESPI is enabled:</p> <p>0: Reading the Baud Rate High and Low registers returns the BRG reload value. If MMEN=1, the BRG is enabled to generate SCK. If MMEN=0, the BRG is disabled.</p> <p>1: Reading the Baud Rate High and Low registers returns the BRG Counter value. If MMEN=1, the BRG is enabled to generate SCK. If MMEN=0 the BRG is enabled to provide a Slave SCK time-out. See the error description in the Slave Mode Abort section on page 293.</p> <p>CAUTION: If reading the counter one byte at a time while the BRG is counting, keep in mind that the values will not be in sync.</p>
[4] PHASE	<p>Phase Select</p> <p>Sets the phase relationship of the data to the clock. For more information about operation of the PHASE bit, see the ESPI Clock Phase and Polarity Control section on page 285.</p>
[3] CLKPOL	<p>Clock Polarity</p> <p>0: SCK idles Low (0). 1: SCK idles High (1).</p>
[2] WOR	<p>Wire OR (Open-Drain) Mode Enabled</p> <p>0: ESPI signal pins not configured for open-drain. 1: All four ESPI signal pins (SCK, SS, MISO and MOSI) configured for open-drain function. This setting is typically used for multi-master and/or multi-slave configurations.</p>
[1] MMEN	<p>ESPI Master Mode Enable</p> <p>This bit controls the data I/O pin selection and SCK direction.</p> <p>0: Data out on MISO, data in on MOSI (used in SPI Slave Mode), SCK is an input. 1: Data out on MOSI, data in on MISO (used in SPI Master Mode), SCK is an output.</p>

15.4.4. ESPI 0-1 Mode Registers

The ESPI 0-1 Mode Registers, shown in Table 147, configure the character bit width and mode of the ESPI I/O pins.

Table 147. ESPI 0-1 Mode Registers (ESPIxMODE)

Bit	7	6	5	4	3	2	1	0
Field	SSMD			NUMBITS[2:0]			SSIO	SSPO
Reset	000			0	0	0	0	0
R/W	R/W			R/W	R/W	R/W	R/W	R/W
Address	ESPI0MODE @ F63h, ESPI1MODE @ F6Bh							
Note: x references bits in the range [1:0].								

Bit	Description
[7:5] SSMD	<p>Slave Select Mode</p> <p>This field selects the behavior of \overline{SS} as a framing signal. For a description of these modes, see the Slave Select section on page 283.</p> <p>000 = SPI Mode</p> <p>When SSIO=1, the \overline{SS} pin is driven directly from the SSV bit in the Transmit Data Command Register. The master software should set SSV (or a GPIO output if the \overline{SS} pin is not connected to the appropriate slave) to the asserted state prior to or on the same clock cycle that the Transmit Data Register is written with the initial byte. At the end of a frame (after the last RDRNE event), SSV will be automatically deasserted by hardware. In this mode, SCK is active only for data transfer (one clock cycle per bit transferred).</p> <p>001 = Loopback Mode</p> <p>When ESPI is configured as master (MMEN=1), the outputs are deasserted and data is looped from Shift Register Out to Shift Register In. When ESPI is configured as a slave (MMEN=0) and \overline{SS} asserts, MISO (slave output) is tied to MOSI (slave input) to provide an asynchronous remote loop back (echo) function.</p> <p>010 = I²S Mode</p> <p>In this mode, the value from SSV will be output by the master on the \overline{SS} pin with one SCK period before the data and will remain in that state until the start of the next frame. Typically, this mode is used to send back-to-back frames with \overline{SS} alternating on each frame. A frame boundary is indicated in the master when SSV changes. A frame boundary is detected in the slave by \overline{SS} changing state. The \overline{SS} framing signal will lead the frame by one SCK period. In this mode, SCK will run continuously, starting with the initial \overline{SS} assertion. Frames will run back-to-back as long as software continues to provide data. An example of this mode is the I²S protocol (Inter IC Sound) which is used to carry left and right channel audio data with the \overline{SS} signal indicating which channel is being sent. In Slave Mode, the change in state of \overline{SS} (Low to High or High to Low) triggers the start of a transaction on the next SCK cycle.</p>

Bit	Description (Continued)
[4:2] NUMBITS[2:0]	<p>Number of Data Bits Per Character to Transfer</p> <p>This field contains the number of bits to shift for each character transfer. To learn more about valid bit positions when the character length is less than 8 bits, see the description of the ESPI 0-1 Data Registers section on page 295.</p> <p>000: 8 bits. 001: 1 bit. 010: 2 bits. 011: 3 bits. 100: 4 bits. 101: 5 bits. 110: 6 bits. 111: 7 bits.</p>
[1] SSIO	<p>Slave Select I/O</p> <p>This bit controls the direction of the \overline{SS} pin. In single Master Mode, SSIO is set to 1 even if a separate GPIO pin is being used to provide the \overline{SS} output function. In the SPI slave or multi-master configuration, SSIO is set to 0.</p> <p>0: \overline{SS} pin configured as an input (SPI slave and multi-master modes). 1: \overline{SS} pin configured as an output (SPI single-master mode).</p>
[0] SSPO	<p>Slave Select Polarity</p> <p>This bit controls the polarity of the \overline{SS} pin.</p> <p>0: \overline{SS} is active Low. (SSV=1 corresponds to \overline{SS}=0). 1: \overline{SS} is active High. (SSV=1 corresponds to \overline{SS}=1).</p>

15.4.5. ESPI 0-1 Status Registers

The ESPI 0-1 Status Registers, shown in Table 148, indicate the current state of the ESPI. All bits revert to their Reset state if the ESPI is disabled.

Table 148. ESPI 0-1 Status Registers (ESPIxSTAT)

Bit	7	6	5	4	3	2	1	0
Field	TDRE	TUND	COL	ABT	ROVR	RDRNE	TFST	SLAS
Reset	1	0	0	0	0	0	0	1
R/W	R	R/W*	R/W*	R/W*	R/W*	R	R	R
Address	ESPI0STAT @ F64h, ESPI1STAT @ F6Ch							
Note: *R/W=read access; write a 1 to clear the bit to 0; x references bits in the range [1:0].								

Bit	Description
[7] TDRE	Transmit Data Register Empty 0: Transmit Data Register is full or ESPI is disabled. 1: Transmit Data Register is empty. A write to the ESPI (Transmit) Data Register clears this bit.
[6] TUND	Transmit Underrun 0: A Transmit Underrun error has not occurred. 1: A Transmit Underrun error has occurred.
[5] COL	Collision 0: A multi-master collision (mode fault) has not occurred. 1: A multi-master collision (mode fault) has occurred.
[4] ABT	Slave Mode Transaction Abort This bit is set if the ESPI is configured in Slave Mode, a transaction is occurring and \overline{SS} deasserts before all bits of a character have been transferred as defined by the NUMBITS field of the ESPIMODE Register. This bit can also be set in Slave Mode by an SCK monitor time-out (MMEN=0, BRGCTL=1). 0: A Slave Mode transaction abort has not occurred. 1: A Slave Mode transaction abort has occurred.
[3] ROVR	Receive Overrun 0: A Receive Overrun error has not occurred. 1: A Receive Overrun error has occurred.
[2] RDRNE	Receive Data Register Not Empty 0: Receive Data Register is empty. 1: Receive Data Register is not empty.

Bit	Description (Continued)
[1] TFST	Transfer Status 0: No data transfer is currently in progress. 1: Data transfer is currently in progress.
[0] SLAS	Slave Select Reading this bit returns the current value of the \overline{SS} pin. 0: The \overline{SS} pin input is Low. 1: The \overline{SS} pin input is High.

15.4.6. ESPI 0-1 State Registers

The ESPI 0-1 State Registers, shown in Table 149, let you observe the ESPI clock, data and internal state.

Table 149. ESPI 0-1 State Registers (ESPIxSTATE)

Bit	7	6	5	4	3	2	1	0
Field	SCKI	SDI	ESPISTATE					
Reset	0	0	0					
R/W	R	R	R					
Address	ESPI0STATE @ F65h, ESPI1STATE @ F6Dh							

Note: x references bits in the range [1:0].

Bit	Description
[7] SCKI	Serial Clock Input This bit reflects the state of the serial clock pin. 0: The SCK input pin is Low. 1: The SCK input pin is High.
[6] SDI	Serial Data Input This bit reflects the state of the serial data input (MOSI or MISO depending on the MMEN bit). 0: The serial data input pin is Low. 1: The serial data input pin is High.
[5:0] ESPISTATE	ESPI State Machine Indicates the current state of the internal ESPI State Machine. This information is intended for manufacturing test purposes. The state values may change in future hardware revisions and are not intended to be used by a software driver.

Table 150 defines the valid ESPI states.

Table 150. ESPISTATE Values

ESPISTATE Value	Description
00_0000	Idle.
00_0001	Slave Wait for SCK.
00_0010	I ² S Slave Mode start delay.
00_0011	I ² S Slave Mode start delay.
01_0000	SPI Master Mode start delay.
11_0001	I ² S Master Mode start delay.
11_0010	I ² S Master Mode start delay.
10_1110	Bit 7 Receive.
10_1111	Bit 7 Transmit.
10_1100	Bit 6 Receive.
10_1101	Bit 6 Transmit.
10_1010	Bit 5 Receive.
10_1011	Bit 5 Transmit.
10_1000	Bit 4 Receive.
10_1001	Bit 4 Transmit.
10_0110	Bit 3 Receive.
10_0111	Bit 3 Transmit.
10_0100	Bit 2 Receive.
10_0101	Bit 2 Transmit.
10_0010	Bit 1 Receive.
10_0011	Bit 1 Transmit.
10_0000	Bit 0 Receive.
10_0001	Bit 0 Transmit.

15.4.7. ESPI 0-1 Baud Rate High and Low Byte Registers

The ESPI 0-1 Baud Rate High and Low Byte registers, shown in Tables 151 and [152](#), combine to form a 16-bit reload value, BRG[15:0], for the ESPI Baud Rate Generator. The ESPI baud rate is calculated using the following equation:

$$\text{SPI Baud Rate (bits/s)} = \frac{\text{System Clock Frequency (Hz)}}{2 \times \text{BRG}[15:0]}$$

The minimum baud rate is obtained by setting BRG[15:0] to 0000h for a clock divisor value of (2 x 65536=131072).

When the ESPI function is disabled, the BRG functions as a basic 16-bit timer with interrupt on time-out.

Follow the procedure below to configure the BRG as a general-purpose timer with interrupt on timeout:

1. Disable the ESPI by setting ESPIEN[1:0]=00 in the SPI Control Register.
2. Load the appropriate 16-bit count value into the ESPI Baud Rate High and Low Byte registers.
3. Enable the BRG timer function and associated interrupt by setting the BRGCTL bit in the ESPI Control Register to 1.

When configured as a general-purpose timer, the SPI BRG interrupt interval is calculated using the following equation:

$$\text{SPI BRG Interrupt Interval (s)} = \text{System Clock Period (s)} \times \text{BRG}[15:0]$$

Table 151. ESPI 0-1 Baud Rate High Byte Registers (ESPIxBRH)

Bit	7	6	5	4	3	2	1	0
Field	BRH							
Reset	1	1	1	1	1	1	1	1
R/W	R/W	R/W	R/W	R/W	R/W	R/W	R/W	R/W
Address	ESPI0BRH @ F66h, ESPI1BRH @ F6Eh							
Note: x references bits in the range [1:0].								

Bit	Description
[7:0]	ESPI Baud Rate High Byte
BRH	The most significant byte, BRG[15:8], of the ESPI Baud Rate Generator's reload value.

Table 152. ESPI 0-1 Baud Rate Low Byte Registers (ESPIxBRL)

Bit	7	6	5	4	3	2	1	0
Field	BRL							
Reset	1	1	1	1	1	1	1	1
R/W	R/W	R/W	R/W	R/W	R/W	R/W	R/W	R/W
Address	ESPI0BRL @ F67h, ESPI1BRL @ F6Fh							

Note: x references bits in the range [1:0].

Bit	Description
[7:0]	ESPI Baud Rate Low Byte
BRL	The least significant byte, BRG[7:0], of the ESPI Baud Rate Generator's reload value.

Chapter 16. I²C Master/Slave Controller

The I²C Master/Slave Controller ensures that the F6482 Series devices are bus-compatible with the I²C protocol. The I²C bus consists of the serial data signal (SDA) and a serial clock signal (SCL) bidirectional lines. The features of the I²C controller include:

- Operates in MASTER/SLAVE or SLAVE ONLY modes
- Supports arbitration in a multimaster environment (MASTER/SLAVE Mode)
- Supports data rates up to 400Kbps
- 7-bit or 10-bit slave address recognition (interrupt-only on address match)
- Optional general call address recognition
- Optional digital filter on receive SDA, SCL lines
- Optional interactive receive mode allows software interpretation of each received address and/or data byte before acknowledging
- Unrestricted number of data bytes per transfer
- Baud Rate Generator can be used as a general-purpose timer with an interrupt if the I²C controller is disabled

16.1. Architecture

Figure 45 shows the architecture of the I²C controller.

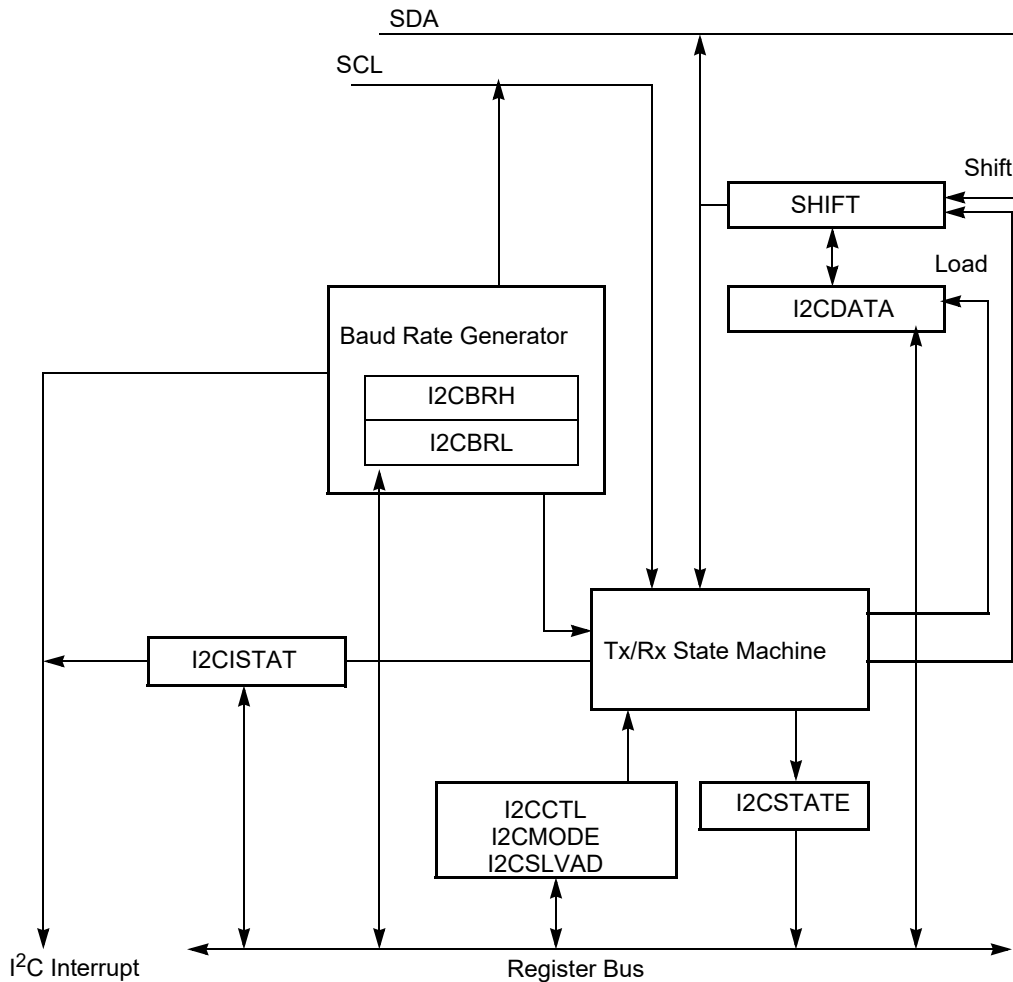

Figure 45. I²C Controller Block Diagram

16.1.1. I²C Master/Slave Controller Registers

Table 153 summarizes the I²C Master/Slave controller's software-accessible registers.

Table 153. I²C Master/Slave Controller Registers

Name	Abbreviation	Description
I ² C Data	I2CDATA	Transmit/receive data register.
I ² C Interrupt Status	I2CISTAT	Interrupt status register.
I ² C Control	I2CCTL	Control register: basic control functions.

Table 153. I²C Master/Slave Controller Registers (Continued)

Name	Abbreviation	Description
I ² C Baud Rate High	I2CBRH	High byte of baud rate generator initialization value.
I ² C Baud Rate Low	I2CBRL	Low byte of baud rate generator initialization value.
I ² C State	I2CSTATE	State register.
I ² C Mode	I2CMODE	Selects MASTER or SLAVE modes, 7-bit or 10-bit addressing; configure address recognition, define slave address bits [9:8].
I ² C Slave Address	I2CSLVAD	Defines slave address bits [7:0].

16.2. Operation

The I²C Master/Slave Controller operates in MASTER/SLAVE Mode, SLAVE ONLY Mode, or with master arbitration. In MASTER/SLAVE Mode, it can be used as the only master on the bus or as one of the several masters on the bus, with arbitration. In a multi-master environment, the controller switches from MASTER to SLAVE Mode on losing arbitration.

Though slave operation is fully supported in MASTER/SLAVE Mode, if a device is intended to operate only as a slave, then SLAVE ONLY Mode can be selected. In SLAVE ONLY Mode, the device will not initiate a transaction, even if the software inadvertently sets the start bit.

16.2.1. SDA and SCL Signals

The I²C circuit sends all addresses, Data and Acknowledge signals over the SDA line, with most-significant bit first. SCL is the clock for the I²C bus. When the SDA and SCL pin alternate functions are selected for their respective GPIO ports, the pins are automatically configured for open-drain operation.

The master is responsible for driving the SCL clock signal. During the Low period of the clock, a slave can hold the SCL signal Low to suspend the transaction if it is not ready to proceed. The master releases the clock at the end of the Low period and notices that the clock remains Low instead of returning to a High level. When the slave releases the clock, the I²C master continues the transaction. All data is transferred in bytes; there is no limit to the amount of data transferred in one operation. When transmitting an address, data, or an Acknowledge, the SDA signal changes in the middle of the Low period of SCL. When receiving an address, data, or an Acknowledge; the SDA signal is sampled in the middle of the High period of SCL.

A low-pass digital filter can be applied to the SDA and SCL receive signals by setting the Filter Enable (FILTEN) bit in the I²C Control Register. When the filter is enabled, any glitch that is less than a system clock period in width will be rejected. This filter should be

enabled when running in I²C FAST Mode (400 KBps) and can also be used at lower data rates.

16.2.2. I²C Interrupts

The I²C controller contains multiple interrupt sources that are combined into one interrupt request signal to the interrupt controller. If the I²C controller is enabled, the source of the interrupt is determined by which bits are set in the I2CISTAT Register. If the I²C controller is disabled, the BRG controller is used to generate general-purpose timer interrupts.

Each interrupt source, other than the baud rate generator interrupt, features an associated bit in the I2CISTAT Register that automatically clears when software reads the register or performs another task, such as reading/writing the Data Register.

16.2.2.1. Transmit Interrupts

Transmit interrupts (i.e., the TDRE bit = 1 in the I2CISTAT Register) occur under the following conditions, both of which must be true:

- The Transmit Data Register is empty and the TXI bit=1 in the I²C Control Register.
- The I²C controller is enabled with one of the following elements:
 - The first bit of a 10-bit address is shifted out.
 - The first bit of the final byte of an address is shifted out and the RD bit is deasserted.
 - The first bit of a data byte is shifted out.

Writing to the I²C Data Register always clears the TRDE bit to 0.

16.2.2.2. Receive Interrupts

Receive interrupts (i.e., the RDRF bit=1 in the I2CISTAT Register) occur when a byte of data has been received by the I²C controller. The RDRF bit is cleared by reading from the I²C Data Register. If the RDRF interrupt is not serviced prior to the completion of the next receive byte, the I²C controller holds SCL Low during the final data bit of the next byte until RDRF is cleared, to prevent receive overruns. A receive interrupt does not occur when a slave receives an address byte or when data bytes following a slave address do not match. An exception is if the Interactive Receive Mode (IRM) bit is set in the I2CMODE Register, in which case receive interrupts occur for all receive address and data bytes in SLAVE Mode.

16.2.2.3. Slave Address Match Interrupts

Slave address match interrupts (i.e., the SAM bit=1 in the I2CISTAT Register) occur when the I²C controller is in SLAVE Mode and a received address matches the unique slave address. The General Call Address (0000_0000) and STARTBYTE (0000_0001) are recognized if the GCE bit=1 in the I2CMODE Register. The software checks the RD

bit in the I2CISTAT Register to determine if the transaction is a read or write transaction. The General Call Address and STARTBYTE address are also distinguished by the RD bit. The General Call Address (GCA) bit of the I2CISTAT Register indicates whether the address match occurred on the unique slave address or the General Call/STARTBYTE address. The SAM bit clears automatically when the I2CISTAT Register is read.

If configured via the MODE[1:0] field of the I²C Mode Register for 7-bit slave addressing, the most significant 7 bits of the first byte of a transaction are compared against the SLA[6:0] bits of the Slave Address Register. If configured for 10-bit slave addressing, the first byte of the transaction is compared against {11110, SLA[9:8], R/W} and the second byte is compared against SLA[7:0].

16.2.2.4. Arbitration Lost Interrupts

Arbitration Lost interrupts (i.e., the ARBLST bit=1 in the I2CISTAT Register) occur when the I²C controller is in MASTER Mode and loses arbitration (outputs 1 on SDA and receives 0 on SDA). The I²C controller switches to SLAVE Mode when this instance occurs. This bit clears automatically when the I2CISTAT Register is read.

16.2.2.5. Stop/Restart Interrupts

A stop/restart event interrupt (i.e., the SPRS bit=1 in the I2CISTAT Register) occurs when the I²C controller is in SLAVE Mode and a stop or restart condition is received, indicating the end of the transaction. The RSTR bit in the I²C State Register indicates whether the bit is set due to a stop or restart condition. When a restart occurs, a new transaction by the same master is expected to follow. This bit is automatically cleared when the I2CISTAT Register is read. The stop/restart interrupt occurs only on a selected (address match) slave.

16.2.2.6. Not Acknowledge Interrupts

Not Acknowledge interrupts (i.e., the NCKI bit=1 in the I2CISTAT Register) occur in MASTER Mode when a Not Acknowledge is received or sent by the I²C controller and the start or stop bit is not set in the I²C Control Register. In MASTER Mode, the Not Acknowledge interrupt clears by setting the start or stop bit. When this interrupt occurs in MASTER Mode, the I²C controller waits until it is cleared before performing any action. In SLAVE Mode, the Not Acknowledge interrupt occurs when a Not Acknowledge is received in response to data sent. The NCKI bit clears in SLAVE Mode when software reads the I2CISTAT Register.

16.2.2.7. General-Purpose Timer Interrupt from Baud Rate Generator

If the I²C controller is disabled (i.e., the IEN bit in the I2CCTL Register=0) and the BIRQS bit in the I2CCTL Register=1, an interrupt is generated when the baud rate generator (BRG) counts down to 1. The baud rate generator reloads and continues counting, providing a periodic interrupt. None of the bits in the I2CISTAT Register are set, allowing the BRG in the I²C controller to be used as a general-purpose timer when the I²C controller is disabled.

16.2.3. Start and Stop Conditions

The master generates the start and stop conditions to start or end a transaction. To start a transaction, the I²C controller generates a start condition by pulling the SDA signal Low while SCL is High. To complete a transaction, the I²C controller generates a stop condition by creating a Low-to-High transition of the SDA signal while the SCL signal is High. These start and stop events occur when the start and stop bits in the I²C Control Register are written by software to begin or end a transaction. Any byte transfer currently under way including the Acknowledge phase finishes before the start or stop condition occurs.

16.2.4. Software Control of I²C Transactions

The I²C controller is configured via the I²C Control and I²C Mode registers. The MODE[1:0] field of the I²C Mode Register allows the configuration of the I²C controller for MASTER/SLAVE or SLAVE ONLY Mode, and configures the slave for 7-bit or 10-bit addressing recognition.

MASTER/SLAVE Mode can be used for:

- MASTER ONLY operation in a *single master/one or more slave* I²C system
- MASTER/SLAVE in a *multimaster/multislave* I²C system
- SLAVE ONLY operation in an I²C system

In SLAVE ONLY Mode, the start bit of the I²C Control Register is ignored (i.e., software cannot initiate a master transaction by accident) and operation to SLAVE ONLY Mode is restricted thereby preventing accidental operation in MASTER Mode. The software controls I²C transactions by enabling the I²C controller interrupt in the interrupt controller or by polling the I²C Status Register.

To use interrupts, the I²C interrupt must be enabled in the interrupt controller and followed by executing an EI instruction. The TXI bit in the I²C Control Register must be set to enable transmit interrupts. An I²C interrupt service routine then checks the I²C Status Register to determine the cause of the interrupt.

To control transactions by polling, the TDRE, RDRF, SAM, ARBLST, SPRS and NCKI interrupt bits in the I²C Status Register should be polled. The TDRE bit asserts regardless of the state of the TXI bit.

16.2.5. Master Transactions

The following sections describe master read and write transactions to both 7-bit and 10-bit slaves.

16.2.5.1. Master Arbitration

If a master loses arbitration during the address byte it releases the SDA line, switches to SLAVE Mode and monitors the address to determine if it is selected as a slave. If a master

loses arbitration during the transmission of a data byte, it releases the SDA line and waits for the next stop or start condition.

The master detects a loss of arbitration when a 1 is transmitted but a 0 is received from the bus in the same bit-time. This loss occurs if more than one master is simultaneously accessing the bus. Loss of arbitration occurs during the address phase (two or more Masters accessing different slaves) or during the data phase, when the masters are attempting to write different data to the same slave.

When a master loses arbitration, the software is informed by means of the Arbitration Lost interrupt. The software can repeat the same transaction at a later time.

A special case can occur when a slave transaction starts just before the software attempts to start a new master transaction by setting the start bit. In this case, the state machine enters its slave states before the start bit is set and as a result the I²C controller will not arbitrate. If a slave address match occurs and the I²C controller receives/transmits data, the start bit is cleared and an Arbitration Lost interrupt is asserted. The software can minimize the chance of this instance occurring by checking the BUSY bit in the I2CSTATE Register before initiating a master transaction. If a slave address match does not occur, the Arbitration Lost interrupt will not occur and the start bit will not be cleared. The I²C controller will initiate the master transaction after the I²C bus is no longer busy.

16.2.5.2. Master Address-Only Transactions

It is sometimes preferable to perform an address-only transaction to determine if a particular slave device is able to respond. This transaction can be performed by monitoring the ACKV bit in the I2CSTATE Register after the address has been written to the I2CDATA Register and the start bit has been set. After the ACKV bit is set, the ACK bit in the I2CSTATE Register determines if the slave is able to communicate. The stop bit must be set in the I2CCTL Register to terminate the transaction without transferring data. For a 10-bit slave address, if the first address byte is acknowledged, the second address byte should also be sent to determine if the preferred slave is responding.

Another approach is to set both the stop and start bits (for sending a 7-bit address). After both bits have been cleared (7-bit address has been sent and transaction is complete), the ACK bit can be read to determine if the slave has acknowledged. For a 10-bit slave, set the stop bit after the second TDRE interrupt (which indicates that the second address byte is being sent).

16.2.5.3. Master Transaction Diagrams

In the following transaction diagrams, the shaded regions indicate the data that is transferred from the master to the slave, and the unshaded regions indicate the data that is transferred from the slave to the master. The transaction field labels are defined as follows:

S Start
W Write

- A Acknowledge
- A Not Acknowledge
- P Stop

16.2.5.4. Master Write Transaction with a 7-Bit Address

Figure 46 shows the data transfer format from a master to a 7-bit addressed slave.

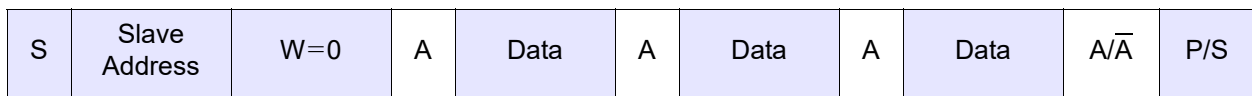

Figure 46. Data Transfer Format, Master Write Transaction with a 7-Bit Address

Observe the following steps for a master transmit operation to a 7-bit addressed slave:

1. The software initializes the MODE field in the I²C Mode Register for MASTER/SLAVE Mode with either a 7-bit or 10-bit slave address. The MODE field selects the address width for this mode when addressed as a slave (but not for the remote slave). The software asserts the IEN bit in the I²C Control Register.
2. The software asserts the TXI bit of the I²C Control Register to enable transmit interrupts.
3. The I²C interrupt asserts, because the I²C Data Register is empty.
4. The software responds to the TDRE bit by writing a 7-bit slave address plus the write bit (which is cleared to 0) to the I²C Data Register.
5. The software sets the start bit of the I²C Control Register.
6. The I²C controller sends a start condition to the I²C slave.
7. The I²C controller loads the I²C Shift Register with the contents of the I²C Data Register.
8. After one bit of the address has been shifted out by the SDA signal, the transmit interrupt asserts.
9. The software responds by writing the transmit data into the I²C Data Register.
10. The I²C controller shifts the remainder of the address and the write bit out via the SDA signal.
11. The I²C slave sends an Acknowledge (by pulling the SDA signal Low) during the next High period of SCL. The I²C controller sets the ACK bit in the I²C Status Register.

If the slave does not acknowledge the address byte, the I²C controller sets the NCKI bit in the I²C Status Register, sets the ACKV bit and clears the ACK bit in the I²C State Register. The software responds to the Not Acknowledge interrupt by setting the

stop bit and clearing the TXI bit. The I²C controller flushes the Transmit Data Register, sends a stop condition on the bus and clears the stop and NCKI bits. The transaction is complete and the following steps can be ignored.

12. The I²C controller loads the contents of the I²C Shift Register with the contents of the I²C Data Register.
13. The I²C controller shifts the data out via the SDA signal. After the first bit is sent, the transmit interrupt asserts.
14. If more bytes remain to be sent, return to [Step 9](#).
15. When there is no more data to be sent, the software responds by setting the stop bit of the I²C Control Register (or the start bit to initiate a new transaction).
16. If no additional transaction is queued by the master, the software can clear the TXI bit of the I²C Control Register.
17. The I²C controller completes transmission of the data on the SDA signal.
18. The I²C controller sends a stop condition to the I²C bus.

► **Note:** If the slave terminates the transaction early by responding with a Not Acknowledge during the transfer, the I²C controller asserts the NCKI interrupt and halts. The software must terminate the transaction by setting either the stop bit (end transaction) or the start bit (end this transaction, start a new one). In this case, it is not necessary for software to set the FLUSH bit of the I2CCTL Register to flush the data that was previously written but not transmitted. The I²C controller hardware automatically flushes transmit data in the Not Acknowledge case.

16.2.5.5. Master Write Transaction with a 10-Bit Address

Figure 47 shows the data transfer format from a master to a 10-bit addressed slave.

S	Slave Address 1st Byte	W=0	A	Slave Address 2nd Byte	A	Data	A	Data	A \bar{A}	F/S
---	---------------------------	-----	---	---------------------------	---	------	---	------	-------------	-----

Figure 47. Data Transfer Format, Master Write Transaction with a 10-Bit Address

The first 7 bits transmitted in the first byte are 11110xx. The 2 xx bits are the two most significant bits of the 10-bit address. The lowest bit of the first byte transferred is the read/write control bit (which is cleared to 0). The transmit operation is performed in the same manner as 7-bit addressing.

Observe the following steps for a master transmit operation to a 10-bit addressed slave:

1. The software initializes the MODE field in the I²C Mode Register for MASTER/SLAVE Mode with 7- or 10-bit addressing (the I²C bus protocol allows the mixing of slave address types). The MODE field selects the address width for this mode when addressed as a slave (but not for the remote slave). The software asserts the IEN bit in the I²C Control Register.
2. The software asserts the TXI bit of the I²C Control Register to enable transmit interrupts.
3. The I²C interrupt asserts because the I²C Data Register is empty.
4. The software responds to the TDRE interrupt by writing the first slave address byte (11110xx0). The least-significant bit must be 0 for the write operation.
5. The software asserts the start bit of the I²C Control Register.
6. The I²C controller sends a start condition to the I²C slave.
7. The I²C controller loads the I²C Shift Register with the contents of the I²C Data Register.
8. After one bit of the address is shifted out by the SDA signal, the transmit interrupt asserts.
9. The software responds by writing the second byte of address into the contents of the I²C Data Register.
10. The I²C controller shifts the remainder of the first byte of the address and the write bit out via the SDA signal.
11. The I²C slave sends an Acknowledge by pulling the SDA signal Low during the next High period of SCL. The I²C controller sets the ACK bit in the I²C Status Register.
If the slave does not acknowledge the first address byte, the I²C controller sets the NCKI bit in the I²C Status Register, sets the ACKV bit and clears the ACK bit in the I²C State Register. The software responds to the Not Acknowledge interrupt by setting the stop bit and clearing the TXI bit. The I²C controller flushes the second address byte from the Data Register, sends a stop condition on the bus, and clears the stop and NCKI bits. The transaction is complete and the following steps can be ignored.
12. The I²C controller loads the I²C Shift Register with the contents of the I²C Data Register (2nd address byte).
13. The I²C controller shifts the second address byte out via the SDA signal. After the first bit has been sent, the transmit interrupt asserts.
14. The software responds by writing the data to be written out to the I²C Control Register.
15. The I²C controller shifts out the remainder of the second byte of the slave address (or ensuring data bytes, if looping) via the SDA signal.

16. The I²C slave sends an Acknowledge by pulling the SDA signal Low during the next High period of SCL. The I²C controller sets the ACK bit in the I²C Status Register. If the slave does not acknowledge, see the second paragraph of [Step 11](#).
17. The I²C controller shifts the data out by the SDA signal. After the first bit is sent, the transmit interrupt asserts.
18. If more bytes remain to be sent, return to [Step 14](#).
19. The software responds by asserting the stop bit of the I²C Control Register.
20. The I²C controller completes transmission of the data on the SDA signal.
21. The I²C controller sends a stop condition to the I²C bus.

► **Note:** If the slave responds with a Not Acknowledge during the transfer, the I²C controller asserts the NCKI bit, sets the ACKV bit, clears the ACK bit in the I²C State Register and halts. The software terminates the transaction by setting either the stop bit (end transaction) or the start bit (end this transaction, start a new one). The Transmit Data Register is flushed automatically.

16.2.5.6. Master Read Transaction with a 7-Bit Address

Figure 48 shows the data transfer format for a read operation to a 7-bit addressed slave.

S	Slave Address	R=1	A	Data	A	Data	A	P/S
---	---------------	-----	---	------	---	------	---	-----

Figure 48. Data Transfer Format, Master Read Transaction with a 7-Bit Address

Observe the following steps for a Master Read operation to a 7-bit addressed slave:

1. The software initializes the MODE field in the I²C Mode Register for MASTER/SLAVE Mode with 7- or 10-bit addressing (the I²C bus protocol allows the mixing of slave address types). The MODE field selects the address width for this mode when addressed as a slave (but not for the remote slave). The software asserts the IEN bit in the I²C Control Register.
2. The software writes the I²C Data Register with a 7-bit slave address, plus the read bit (which is set to 1).
3. The software asserts the start bit of the I²C Control Register.
4. If this operation is a single-byte transfer, the software asserts the NAK bit of the I²C Control Register so that after the first byte of data has been read by the I²C controller, a Not Acknowledge instruction is sent to the I²C slave.
5. The I²C controller sends a start condition.

6. The I²C controller sends the address and read bit out via the SDA signal.
7. The I²C slave acknowledges the address by pulling the SDA signal Low during the next High period of SCL.

If the slave does not acknowledge the address byte, the I²C controller sets the NCKI bit in the I²C Status Register, sets the ACKV bit and clears the ACK bit in the I²C State Register. The software responds to the Not Acknowledge interrupt by setting the stop bit. The I²C controller sends a stop condition on the bus and clears the stop and NCKI bits. The transaction is complete and the following steps can be ignored.

8. The I²C controller shifts in a byte of data from the I²C slave.
9. The I²C controller asserts the receive interrupt.
10. The software responds by reading the I²C Data Register. If the next data byte is to be the final byte, the software must set the NAK bit of the I²C Control Register.
11. The I²C controller sends an Acknowledge or Not Acknowledge to the I²C slave based on the value of the NAK bit.
12. If there are more bytes to transfer, the I²C controller returns to [Step 8](#).
13. A NAK interrupt (NCKI bit in I2CISTAT) is generated by the I²C controller.
14. The software responds by setting the stop bit of the I²C Control Register.
15. A stop condition is sent to the I²C slave.

16.2.5.7. Master Read Transaction with a 10-Bit Address

Figure 49 shows the read transaction format for a 10-bit addressed slave.

S	Slave Address 1st Byte	W=0	A	Slave Address 2nd Byte	A	S	Slave Address 1st Byte	R=1	A	Data	A	Data	A	P
---	---------------------------	-----	---	---------------------------	---	---	---------------------------	-----	---	------	---	------	---	---

Figure 49. Data Transfer Format, Master Read Transaction with a 10-Bit Address

The first 7 bits transmitted in the first byte are 11110xx. The two xx bits are the two most-significant bits of the 10-bit address. The lowest bit of the first byte transferred is the write control bit.

Observe the following data transfer procedure for a read operation to a 10-bit addressed slave:

1. The software initializes the MODE field in the I²C Mode Register for MASTER/SLAVE Mode with 7- or 10-bit addressing (the I²C bus protocol allows the mixing of slave address types). The MODE field selects the address width for this mode when addressed as a slave (but not for the remote slave). The software asserts the IEN bit in the I²C Control Register.

2. The software writes 11110b, followed by the two most-significant address bits and a 0 (write) to the I²C Data Register.
3. The software asserts the start bit of the I²C Control Register.
4. The I²C controller sends a start condition.
5. The I²C controller loads the I²C Shift Register with the contents of the I²C Data Register.
6. After the first bit has been shifted out, a transmit interrupt is asserted.
7. The software responds by writing the least significant eight bits of address to the I²C Data Register.
8. The I²C controller completes shifting of the first address byte.
9. The I²C slave sends an Acknowledge by pulling the SDA signal Low during the next High period of SCL.

If the slave does not acknowledge the address byte, the I²C controller sets the NCKI bit in the I²C Status Register, sets the ACKV bit and clears the ACK bit in the I²C State Register. The software responds to the Not Acknowledge interrupt by setting the stop bit. The I²C controller flushes the Transmit Data Register, sends the stop condition on the bus and clears the stop and NCKI bits. The transaction is complete and the following steps can be ignored.

10. The I²C controller loads the I²C Shift Register with the contents of the I²C Data Register (the lower byte of the 10-bit address).
11. The I²C controller shifts out the next eight bits of the address. After the first bit shifts, the I²C controller generates a transmit interrupt.
12. The software responds by setting the start bit of the I²C Control Register to generate a repeated start condition.
13. The software writes 11110b, followed by the 2-bit slave address and a 1 (read) to the I²C Data Register.
14. If the user chooses to read-only one byte, the software responds by setting the NAK bit of the I²C Control Register.
15. After the I²C controller shifts out the address bits listed in [Step 9](#) (the second address transfer), the I²C slave sends an Acknowledge by pulling the SDA signal Low during the next High period of SCL.

If the slave does not acknowledge the address byte, the I²C controller sets the NCKI bit in the I²C Status Register, sets the ACKV bit and clears the ACK bit in the I²C State Register. The software responds to the Not Acknowledge interrupt by setting the stop bit. The I²C controller flushes the Transmit Data Register, sends the stop condition on the bus and clears the stop and NCKI bits. The transaction is complete and the following steps can be ignored.

16. The I²C controller sends a repeated start condition.
17. The I²C controller loads the I²C Shift Register with the contents of the I²C Data Register (the third address transfer).
18. The I²C controller sends 11110b, followed by the two most-significant bits of the slave read address and a 1 (read).
19. The I²C slave sends an Acknowledge by pulling the SDA signal Low during the next High period of SCL.
20. The I²C controller shifts in a byte of data from the slave.
21. The I²C controller asserts the Receive interrupt.
22. The software responds by reading the I²C Data Register. If the next data byte is to be the final byte, the software must set the NAK bit of the I²C Control Register.
23. The I²C controller sends an Acknowledge or Not Acknowledge to the I²C slave, based on the value of the NAK bit.
24. If there are more bytes to transfer, the I²C controller returns to [Step 20](#).
25. The I²C controller generates a NAK interrupt (the NCKI bit in the I2CISTAT Register).
26. The software responds by setting the stop bit of the I²C Control Register.
27. A stop condition is sent to the I²C slave.

16.2.6. Slave Transactions

The following subsections describe read and write transactions to the I²C controller configured for 7-bit and 10-bit slave modes.

16.2.6.1. Slave Address Recognition

The following two slave address recognition options are supported; a description of each follows.

- Slave 7-Bit Address Recognition Mode
- Slave 10-Bit Address Recognition Mode

Slave 7-Bit Address Recognition Mode. If IRM=0 during the address phase and the controller is configured for MASTER/SLAVE or SLAVE 7-BIT ADDRESS Mode, the hardware detects a match to the 7-bit slave address defined in the I2CSLVAD Register and generates the slave address match interrupt (the SAM bit=1 in the I2CISTAT Register). The I²C controller automatically responds during the Acknowledge phase with the value in the NAK bit of the I2CCTL Register.

Slave 10-Bit Address Recognition Mode. If IRM=0 during the address phase and the controller is configured for MASTER/SLAVE or SLAVE 10-BIT ADDRESS Mode, the hardware detects a match to the 10-bit slave address defined in the I2CMODE and I2CSLVAD registers and generates the slave address match interrupt (the SAM bit=1 in the I2CISTAT Register). The I²C controller automatically responds during the Acknowledge phase with the value in the NAK bit of the I2CCTL Register.

16.2.6.2. General Call and Start Byte Address Recognition

If GCE=1 and IRM=0 during the address phase and the controller is configured for master/slave or slave in either 7- or 10-bit address modes, the hardware detects a match to the General Call Address or the start byte and generates the slave address match interrupt. A General Call Address is a 7-bit address of all zeroes, with the R/ \bar{W} bit=0. A start byte is a 7-bit address of all zeroes, with the R/ \bar{W} bit=1. The SAM and GCA bits are set in the I2CISTAT Register. The RD bit in the I2CISTAT Register distinguishes a General Call Address from a start byte which is cleared to 0 for a General Call Address). For a General Call Address, the I²C controller automatically responds during the address acknowledge phase with the value in the NAK bit of the I2CCTL Register. If the software is set to process the data bytes associated with the GCA bit, the IRM bit can optionally be set following the SAM interrupt to allow the software to examine each received data byte before deciding to set or clear the NAK bit. A start byte will not be acknowledged – a requirement of the I²C specification.

16.2.6.3. Software Address Recognition

To disable hardware address recognition, the IRM bit must be set to 1 prior to the reception of the address byte(s). When IRM=1, each received byte generates a receive interrupt (RDRF=1 in the I2CISTAT Register). The software must examine each byte and determine whether to set or clear the NAK bit. The slave holds SCL Low during the acknowledge phase until the software responds by writing to the I2CCTL Register. The value written to the NAK bit is used by the controller to drive the I²C bus, then releasing the SCL. The SAM and GCA bits are not set when IRM=1 during the address phase, but the RD bit is updated based on the first address byte.

16.2.6.4. Slave Transaction Diagrams

In the following transaction diagrams, the shaded regions indicate data transferred from the master to the slave and the unshaded regions indicate the data transferred from the slave to the master. The transaction field labels are defined as follows:

S	Start
W	Write
A	Acknowledge
A	Not Acknowledge
P	Stop

16.2.6.5. Slave Receive Transaction with 7-Bit Address

The data transfer format for writing data from a master to a slave in 7-bit address mode is shown in Figure 50. The procedure that follows describes the I²C Master/Slave Controller operating as a slave in 7-bit addressing mode and receiving data from the bus master.

S	Slave Address	W=0	A	Data	A	Data	A	Data	A/ \bar{A}	P/S
---	---------------	-----	---	------	---	------	---	------	--------------	-----

Figure 50. Data Transfer Format, Slave Receive Transaction with 7-Bit Address

1. The software configures the controller for operation as a slave in 7-bit addressing mode, as follows:
 - a. Initialize the MODE field in the I²C Mode Register for either SLAVE ONLY Mode or MASTER/SLAVE Mode with 7-bit addressing.
 - b. Optionally set the GCE bit.
 - c. Initialize the SLA[6:0] bits in the I²C Slave Address Register.
 - d. Set IEN=1 in the I²C Control Register. Set NAK=0 in the I²C Control Register.
2. The bus master initiates a transfer, sending the address byte. In SLAVE Mode, the I²C controller recognizes its own address and detects that R/ \bar{W} bit=0 (written from the master to the slave). The I²C controller acknowledges, indicating it is available to accept the transaction. The SAM bit in the I2CISTAT Register is set to 1, causing an interrupt. The RD bit in the I2CISTAT Register is cleared to 0, indicating a write to the slave. The I²C controller holds the SCL signal Low, waiting for the software to load the first data byte.
3. The software responds to the interrupt by reading the I2CISTAT Register (which clears the SAM bit). After seeing the SAM bit to 1, the software checks the RD bit. Because RD=0, no immediate action is required until the first byte of data is received. If software is only able to accept a single byte, it sets the NAK bit in the I2CCTL Register at this time.
4. The master detects the Acknowledge and sends the byte of data.
5. The I²C controller receives the data byte and responds with an Acknowledge or a Not Acknowledge, depending on the state of the NAK bit in the I2CCTL Register. The I²C controller generates the receive data interrupt by setting the RDRF bit in the I2CISTAT Register.
6. The software responds by reading the I2CISTAT Register, finding the RDRF bit=1 and reading the I2CDATA Register clearing the RDRF bit. If software can accept only one more data byte, it sets the NAK bit in the I2CCTL Register.
7. The master and slave loops through [Step 4](#) to [Step 6](#) until the master detects a Not Acknowledge instruction or runs out of data to send.

8. The master sends the stop or restart signal on the bus. Either of these signals can cause the I²C controller to assert a stop interrupt (the stop bit=1 in the I2CISTAT Register). Because the slave received data from the master, the software takes no action in response to the stop interrupt other than reading the I2CISTAT Register to clear the stop bit in the I2CISTAT Register.

16.2.6.6. Slave Receive Transaction with 10-Bit Address

The data transfer format for writing data from a master to a slave with 10-bit addressing is shown in Figure 51. The procedure that follows describes the I²C Master/Slave Controller operating as a slave in 10-bit addressing mode and receiving data from the bus master.

S	Slave Address 1st Byte	W=0	A	Slave Address 2nd Byte	A	Data	A	Data	A/ \bar{A}	P/S
---	---------------------------	-----	---	---------------------------	---	------	---	------	--------------	-----

Figure 51. Data Transfer Format, Slave Receive Transaction with 10-Bit Address

1. The software configures the controller for operation as a slave in 10-bit addressing mode, as follows:
 - a. Initialize the MODE field in the I2CMODE Register for either SLAVE ONLY Mode or MASTER/SLAVE Mode with 10-bit addressing.
 - b. Optionally set the GCE bit.
 - c. Initialize the SLA[7:0] bits in the I2CSLVAD Register and the SLA[9:8] bits in the I2CMODE Register.
 - d. Set IEN=1 in the I2CCTL Register. Set NAK=0 in the I²C Control Register.
2. The master initiates a transfer, sending the first address byte. The I²C controller recognizes the start of a 10-bit address with a match to SLA[9:8] and detects R/ \bar{W} bit=0 (a write from the master to the slave). The I²C controller acknowledges, indicating it is available to accept the transaction.
3. The master sends the second address byte. The SLAVE Mode I²C controller detects an address match between the second address byte and SLA[7:0]. The SAM bit in the I2CISTAT Register is set to 1, thereby causing an interrupt. The RD bit is cleared to 0, indicating a write to the slave. The I²C controller acknowledges, indicating it is available to accept the data.
4. The software responds to the interrupt by reading the I2CISTAT Register, which clears the SAM bit. Because RD=0, no immediate action is taken by the software until the first byte of data is received. If the software is only able to accept a single byte, it sets the NAK bit in the I2CCTL Register.
5. The master detects the Acknowledge and sends the first byte of data.

6. The I²C controller receives the first byte and responds with Acknowledge or Not Acknowledge, depending on the state of the NAK bit in the I2CCTL Register. The I²C controller generates the receive data interrupt by setting the RDRF bit in the I2CISTAT Register.
7. The software responds by reading the I2CISTAT Register, finding the RDRF bit=1 and then reading the I2CDATA Register, which clears the RDRF bit. If the software can accept only one more data byte, it sets the NAK bit in the I2CCTL Register.
8. The master and slave loops through [Step 5](#) to [Step 7](#) until the master detects a Not Acknowledge instruction or runs out of data to send.
9. The master sends the stop or restart signal on the bus. Either of these signals can cause the I²C controller to assert the stop interrupt (the stop bit=1 in the I2CISTAT Register). Because the slave received data from the master, the software takes no action in response to the stop interrupt other than reading the I2CISTAT Register to clear the stop bit.

16.2.6.7. Slave Transmit Transaction With 7-Bit Address

The data transfer format for a master reading data from a slave in 7-bit address mode is shown in Figure 52. The procedure that follows describes the I²C Master/Slave Controller operating as a slave in 7-bit addressing mode and transmitting data to the bus master.

S	Slave Address	R=1	A	Data	A	Data	\bar{A}	P/S
---	---------------	-----	---	------	---	------	-----------	-----

Figure 52. Data Transfer Format, Slave Transmit Transaction with 7-bit Address

1. The software configures the controller for operation as a slave in 7-bit addressing mode, as follows:
 - a. Initialize the MODE field in the I²C Mode Register for either SLAVE ONLY Mode or MASTER/SLAVE Mode with 7-bit addressing.
 - b. Optionally set the GCE bit.
 - c. Initialize the SLA[6:0] bits in the I²C Slave Address Register.
 - d. Set IEN=1 in the I²C Control Register. Set NAK=0 in the I²C Control Register.
2. The master initiates a transfer by sending the address byte. The SLAVE Mode I²C controller finds an address match and detects that the R/ \bar{W} bit=1 (read by the master from the slave). The I²C controller acknowledges, indicating that it is ready to accept the transaction. The SAM bit in the I2CISTAT Register is set to 1, causing an interrupt. The RD bit is set to 1, indicating a read from the slave.
3. The software responds to the interrupt by reading the I2CISTAT Register, thereby clearing the SAM bit. Because RD=1, the software responds by loading the first data byte into the I2CDATA Register. The software sets the TXI bit in the I2CCTL Regis-

ter to enable transmit interrupts. When the master initiates the data transfer, the I²C controller holds SCL Low until the software has written the first data byte to the I2CDATA Register.

4. SCL is released and the first data byte is shifted out.
5. After the first bit of the first data byte has been transferred, the I²C controller sets the TDRE bit, which asserts the transmit data interrupt.
6. The software responds to the transmit data interrupt (TDRE=1) by loading the next data byte into the I2CDATA Register, which clears TDRE.
7. After the data byte has been received by the master, the master transmits an Acknowledge instruction (or a Not Acknowledge instruction if this byte is the final data byte).
8. The bus cycles through [Step 5](#) to [Step 7](#) until the final byte has been transferred. If the software has not yet loaded the next data byte when the master brings SCL Low to transfer the most significant data bit, the slave I²C controller holds SCL Low until the Data Register has been written. When a Not Acknowledge instruction is received by the slave, the I²C controller sets the NCKI bit in the I2CISTAT Register, causing the Not Acknowledge interrupt to be generated.
9. The software responds to the Not Acknowledge interrupt by clearing the TXI bit in the I2CCTL Register, and by asserting the FLUSH bit of the I2CCTL Register to *empty* the Data Register.
10. When the master has completed the final acknowledge cycle, it asserts a stop or restart condition on the bus.
11. The slave I²C controller asserts the stop/restart interrupt (i.e., sets the SPRS bit in the I2CISTAT Register).
12. The software responds to the stop/restart interrupt by reading the I2CISTAT Register, which clears the SPRS bit.

16.2.6.8. Slave Transmit Transaction With 10-Bit Address

The data transfer format for a master reading data from a slave with 10-bit addressing is shown in Figure 53. The following procedure describes the I²C Master/Slave Controller operating as a slave in 10-bit addressing mode, transmitting data to the bus master.

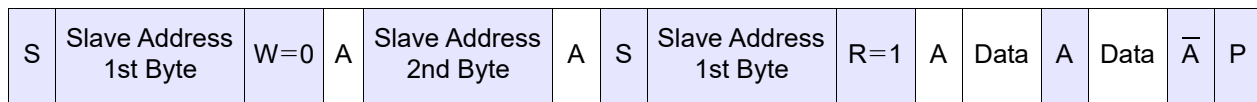

Figure 53. Data Transfer Format, Slave Transmit Transaction with 10-Bit Address

1. The software configures the controller for operation as a slave in 10-bit addressing mode.

- a. Initialize the MODE field in the I²C Mode Register for either SLAVE ONLY Mode or MASTER/SLAVE Mode with 10-bit addressing.
 - b. Optionally set the GCE bit.
 - c. Initialize the SLA[7:0] bits in the I2CSLVAD Register and SLA[9:8] in the I²C MODE Register.
 - d. Set IEN=1 and NAK=0 in the I²C Control Register.
2. The master initiates a transfer by sending the first address byte. The SLAVE Mode I²C controller recognizes the start of a 10-bit address with a match to SLA[9:8], and detects R/W bit=0 (i.e., a write from the master to the slave). The I²C controller acknowledges, indicating it is available to accept the transaction.
 3. The master sends the second address byte. The SLAVE Mode I²C controller compares the second address byte with the value in SLA[7:0]. If there is a match, the SAM bit in the I2CISTAT Register is set=1, causing a slave address match interrupt. The RD bit is set=0, indicating a write to the slave. If a match occurs, the I²C controller acknowledges on the I²C bus, indicating it is available to accept the data.
 4. The software responds to the slave address match interrupt by reading the I2CISTAT Register, which clears the SAM bit. Because the RD bit=0, no further action is required.
 5. The master sees the Acknowledge and sends a restart instruction, followed by the first address byte with R/W set to 1. The SLAVE Mode I²C controller recognizes the restart instruction, follows with the first address byte with a match to SLA[9:8], and detects R/W=1 (i.e., the master reads from the slave). The slave I²C controller sets the SAM bit in the I2CISTAT Register, which causes the slave address match interrupt. The RD bit is set=1. The SLAVE Mode I²C controller acknowledges on the bus.
 6. The software responds to the interrupt by reading the I2CISTAT Register and clearing the SAM bit. The software loads the initial data byte into the I2CDATA Register and sets the TXI bit in the I2CCTL Register.
 7. The master starts the data transfer by asserting SCL Low. After the I²C controller has data available to transmit, the SCL is released and the master proceeds to shift the first data byte.
 8. After the first bit of the first data byte has been transferred, the I²C controller sets the TDRE bit which asserts the transmit data interrupt.
 9. The software responds to the transmit data interrupt by loading the next data byte into the I2CDATA Register.
 10. The I²C master shifts in the remainder of the data byte. The master transmits the Acknowledge (or Not Acknowledge, if this byte is the final data byte).
 11. The bus cycles through [Step 7](#) to [Step 10](#) until the final byte is transferred. If the software has not yet loaded the next data byte when the master brings SCL Low to trans-

fer the most significant data bit, the slave I²C controller holds SCL Low until the Data Register is written.

When a Not Acknowledge is received by the slave, the I²C controller sets the NCKI bit in the I2CISTAT Register, causing the NAK interrupt to be generated.

12. The software responds to the NAK interrupt by clearing the TXI bit in the I2CCTL Register and by asserting the FLUSH bit of the I2CCTL Register.
13. When the master has completed the Acknowledge cycle of the last transfer, it asserts a stop or restart condition on the bus.
14. The slave I²C controller asserts the stop/restart interrupt (i.e., sets the SPRS bit in the I2CISTAT Register).
15. The software responds to the stop interrupt by reading the I2CISTAT Register and clearing the SPRS bit.

16.2.7. DMA Control of I²C Transactions

The DMA engine is configured to support transmit and receive DMA requests from the I²C Controller. The I²C data interrupt requests must be disabled by setting the DMAIF bit in the I²C Mode Register and clearing the TXI bit in the I²C Control Register. These actions allow error condition interrupts to be handled by software while data movement is handled by the DMA engine.

The DMA interface on the I²C Controller is intended to support data transfer but not MASTER Mode address byte transfer. The start, stop, and NAK bits must be controlled by software.

A summary of I²C transfer of data using the DMA follows.

16.2.7.1. Master Write Transaction with Data DMA

- Configure the selected DMA channel for I²C transmit. The IEOb bit must be set in the DMAxCTL0 Register for the last buffer to be transferred.
- The I²C interrupt must be enabled in the interrupt controller to alert software of any I²C error conditions. A Not Acknowledge interrupt occurs on the last byte transferred.
- The I²C master/slave must be configured as defined in the sections above describing MASTER Mode transactions. The TXI bit in the I2CCTL Register must be cleared.
- Initiate the I²C transaction, as described in the [Master Address-Only Transactions](#) section on page 312, using the ACKV and ACK bits in the I2CSTATE Register to determine if the slave acknowledges.
- Set the DMAIF bit in the I2CMODE Register.
- The DMA transfers the data, which is to be transmitted to the slave.

- When the DMA interrupt occurs, poll the I2CSTAT Register until the TDRE bit=1. This polling sequence ensures that the I²C master/slave hardware has commenced transmitting the last byte written by the DMA.
- Set the stop bit in the I2CCTL Register. The stop bit is polled by software to determine when the transaction is actually completed.
- Clear the DMAIF bit in the I2CMODE Register.

► **Note:** If the slave sends a Not Acknowledge prior to the last byte, a Not Acknowledge interrupt occurs. Software must respond to this interrupt by clearing the DMAIF bit and setting the stop bit to end the transaction.

16.2.7.2. Master Read Transaction with Data DMA

In master read transactions, the master is responsible for the Acknowledge for each data byte transferred. The master software must set the NAK bit after the next to the last data byte has been received, or while the last byte is being received. The DMA supports these actions by setting the DMA watermark to 1, which results in a DMA interrupt when the next-to-the-last byte has been received. A DMA interrupt also occurs when the last byte is received. Otherwise, the sequence is similar to the sequence for the master write transaction described in the previous subsection.

- Configure the selected DMA channel for I²C receive. The IEOB bit must be set in the DMAxCTL0 Register for the last buffer to be transferred. Typically, one buffer is defined with a transfer length of N, in which N bytes are expected to be read from the slave. The watermark is set to 1 by setting WMCNT to 0001 in the DMAxCNTH Register.
- The I²C interrupt must be enabled in the interrupt controller to alert software of any I²C error conditions. A Not Acknowledge interrupt occurs on the last byte transferred.
- The I²C master/slave must be configured as defined in a previous section describing MASTER Mode transactions. The TXI bit in the I2CCTL Register must be cleared.
- Initiate the I²C transaction as described in the [Master Address-Only Transactions](#) section on page 312, using the ACKV and ACK bits in the I2CSTATE Register to determine if the slave acknowledges. Do not set the stop bit unless ACKV=1 and ACK=0 (i.e., slave did not acknowledge).
- Set the DMAIF bit in the I2CMODE Register.
- The DMA transfers the data to memory as it is received from the slave.
- When the first DMA interrupt occurs indicating the (N-1)st byte has been received, the NAK bit must be set in the I2CCTL Register.

- When the second DMA interrupt occurs, it indicates that the Nth byte has been received. Set the stop bit in the I2CCTL Register; this stop bit is polled by software to determine when the transaction is actually completed.
- Clear the DMAIF bit in the I2CMODE Register.

16.2.7.3. Slave Write Transaction with Data DMA

In a transaction in which the I²C master/slave operates as a slave that receives data written by a master, the software must set the NAK bit after the (N–1)st byte has been received or during the reception of the last byte. As in the Master Read transaction described previously, the watermark DMA interrupt is used to notify software when the (N–1)st byte has been received.

- Configure the selected DMA channel for I²C receive. The IEOB bit must be set in the DMAxCTL0 Register for the last buffer to be transferred. Typically, one buffer will be defined with a transfer length of N where N bytes are expected to be received from the master. The watermark is set to 1 by setting WMCNT to 0001 in the DMAxCNTH Register.
- The I²C interrupt must be enabled in the interrupt controller to alert software of any I²C error conditions.
- The I²C master/slave must be configured as defined in a previous section describing SLAVE Mode transactions. The TXI bit in the I2CCTL Register must be cleared.
- When the SAM interrupt occurs, set the DMAIF bit in the I2CMODE Register.
- The DMA transfers the data to memory as it is received from the master.
- When the first DMA interrupt occurs indicating that the (N–1)st byte is received, the NAK bit must be set in the I2CCTL Register.
- When the second DMA interrupt occurs, it indicates that the Nth byte is received. A stop I²C interrupt occurs (SPRS bit set in the I2CSTAT Register) when the master issues the stop (or restart) condition.
- Clear the DMAIF bit in the I2CMODE Register.

16.2.7.4. Slave Read Transaction with Data DMA

In this transaction the I²C master/slave operates as a slave, sending data to the master.

- Configure the selected DMA channel for I²C transmit. The IEOB bit must be set in the DMAxCTL0 Register for the last buffer to be transferred. Typically, a single buffer with a transfer length of N is defined.
- The I²C interrupt must be enabled in the interrupt controller to alert software of any I²C error conditions. A Not Acknowledge interrupt occurs on the last byte transferred.
- The I²C master/slave must be configured as defined in the sections above describing SLAVE Mode transactions. The TXI bit in the I2CCTL Register must be cleared.

- When the SAM interrupt occurs, set the DMAIF bit in the I2CMODE Register.
- The DMA transfers the data to be transmitted to the master.
- When the DMA interrupt occurs, the last byte is being transferred to the master. The master must send a Not Acknowledge for this last byte, setting the NCKI bit in the I2CSTAT Register and generating the I²C interrupt. A stop or restart interrupt follows (i.e., the SPRS bit is set in the I2CSTAT Register).
- Clear the DMAIF bit in the I2CMODE Register.

► **Note:** If the master sends a Not Acknowledge prior to the last byte, software responds to the Not Acknowledge interrupt by clearing the DMAIF bit.

16.3. I²C Control Register Definitions

The I²C Control registers are described in this section.

16.3.1. I²C Data Register

The I²C Data Register listed in Table 154 contains the data that is to be loaded into the Shift Register to transmit onto the I²C bus. This register also contains data that is loaded from the Shift Register after it is received from the I²C bus. The I²C Shift Register is not accessible in the Register File address space, but is used only to buffer incoming and outgoing data.

Writes by the software to the I2CDATA Register are blocked if a slave write transaction is underway (the I²C controller is in SLAVE Mode and data is being received).

Table 154. I²C Data Register (I2CDATA=F50h)

Bit	7	6	5	4	3	2	1	0
Field	Data 7	Data 6	Data 5	Data 4	Data 3	Data 2	Data 1	Data 0
Reset	0	0	0	0	0	0	0	0
R/W	R/W	R/W	R/W	R/W	R/W	R/W	R/W	R/W
Address	F50h							

Bit	Description
[7:0] DATA	I ² C Data Byte

16.3.2. I²C Interrupt Status Register

The read-only I²C Interrupt Status Register, shown in Table 155, indicates the cause of any current I²C interrupt and provides the status of the I²C controller. When an interrupt occurs, one or more of the TDRE, RDRF, SAM, ARBLST, SPRS or NCKI bits is set. The GCA and RD bits do not generate an interrupt, but instead provide the status associated with the SAM bit interrupt.

Table 155. I²C Interrupt Status Register (I2CISTAT=F51h)

Bit	7	6	5	4	3	2	1	0
Field	TDRE	RDRF	SAM	GCA	RD	ARBLST	SPRS	NCKI
Reset	1	0	0	0	0	0	0	0
R/W	R	R	R	R	R	R	R	R
Address	F51h							

Bit	Description
[7] TDRE	Transmit Data Register Empty When the I ² C controller is enabled, this bit is 1 when the I ² C Data Register is empty. When set, this bit causes the I ² C controller to generate an interrupt, except when the I ² C controller is shifting in data during the reception of a byte or when shifting an address and the RD bit is set. This bit clears by writing to the I2CDATA Register.
[6] RDRF	Receive Data Register Full This bit is set=1 when the I ² C controller is enabled and the I ² C controller has received a byte of data. When asserted, this bit causes the I ² C controller to generate an interrupt. This bit clears by reading the I2CDATA Register.
[5] SAM	Slave Address Match This bit is set=1 if the I ² C controller is enabled in SLAVE Mode and an address is received that matches the unique slave address or General Call Address (if enabled by the GCE bit in the I ² C Mode Register). In 10-bit addressing mode, this bit is not set until a match is achieved on both address bytes. When this bit is set, the RD and GCA bits are also valid. This bit clears by reading the I2CISTAT Register.
[4] GCA	General Call Address This bit is set in SLAVE Mode when the General Call Address or start byte is recognized (in either 7 or 10 bit SLAVE Mode). The GCE bit in the I ² C Mode Register must be set to enable recognition of the General Call Address and start byte. This bit clears when IEN=0 and is updated following the first address byte of each SLAVE Mode transaction. A General Call Address is distinguished from a start byte by the value of the RD bit (RD=0 for General Call Address, 1 for start byte).
[3] RD	Read This bit indicates the direction of transfer of the data. It is set when the master is reading data from the slave. This bit matches the least-significant bit of the address byte after the start condition occurs (for both MASTER and SLAVE modes). This bit clears when IEN=0, and is updated following the first address byte of each transaction.

Bit	Description (Continued)
[2] ARBLST	Arbitration Lost This bit is set when the I ² C controller is enabled in MASTER Mode and loses arbitration (i.e., outputs a 1 on SDA and receives a 0 on SDA). The ARBLST bit clears when the I2CISTAT Register is read.
[1] SPRS	Stop/Restart Condition Interrupt This bit is set when the I ² C controller is enabled in SLAVE Mode, and detects a stop or restart condition during a transaction directed to this slave. This bit clears when the I2CISTAT Register is read. Read the RSTR bit of the I2CSTATE Register to determine whether the interrupt was caused by a stop or restart condition.
[0] NCKI	NAK Interrupt In MASTER Mode, this bit is set when a Not Acknowledge condition is received or sent, and neither the start nor the stop bit is active. In MASTER Mode, this bit can only be cleared by setting the start or stop bits. In SLAVE Mode, this bit is set when a Not Acknowledge condition is received (i.e., a master reading data from a slave), indicating that the master is finished reading. A stop or restart condition follows. In SLAVE Mode this bit clears when the I2CISTAT Register is read.

16.3.3. I²C Control Register

The I²C Control Register, shown in Table 156, enables and configures I²C operation.

Note: The R/W1 bit can be set (written to 1) when IEN=1, but cannot be cleared (written to 0).

Table 156. I²C Control Register (I2CCTL)

Bit	7	6	5	4	3	2	1	0
Field	IEN	START	STOP	BIRQS	TXI	NAK	FLUSH	FILTEN
Reset	0	0	0	0	0	0	0	0
R/W	R/W	R/W1	R/W1	R/W	R/W	R/W1	W	R/W
Address	F52h							

Bit	Description
[7] IEN	I²C Enable This bit enables the I ² C controller.

Bit	Description (Continued)
[6] START	Send Start Condition When set, this bit causes the I ² C controller (when configured as the master) to send a start condition. After it is asserted, this bit is cleared by the I ² C controller after it sends the start condition or by deasserting the IEN bit. If this bit is 1, it cannot be cleared by writing to the bit. After this bit is set, a start condition is sent if there is data in the I2CDATA or I ² C Shift Register. If there is no data in one of these registers, the I ² C controller waits until data is loaded. If this bit is set while the I ² C controller is shifting out data, it generates a restart condition after the byte shifts and the Acknowledge phase completes. If the stop bit is also set, it waits until the stop condition is sent before the start condition. If start is set while a SLAVE Mode transaction is underway to this device, the start bit will be cleared and ARBLST bit in the Interrupt Status Register will be set.
[5] STOP	Send Stop Condition When set, this bit causes the I ² C controller (when configured as the master) to send the stop condition after the byte in the I ² C Shift Register has completed transmission or after a byte is received in a receive operation. When set, this bit is reset by the I ² C controller after a stop condition has been sent or by deasserting the IEN bit. If this bit is 1, it cannot be cleared to 0 by writing to the register. If a stop is set while a SLAVE Mode transaction is underway, the stop bit is cleared by hardware.
[4] BIRQS	Baud Rate Generator Interrupt Request Select This bit is ignored when the I ² C controller is enabled. If this bit is set=1 when the I ² C controller is disabled (IEN=0), the baud rate generator is used as an additional timer causing an interrupt to occur every time the baud rate generator counts down to one. The baud rate generator runs continuously in this mode, generating periodic interrupts.
[3] TXI	Enable TDRE Interrupts This bit enables interrupts when the I ² C Data Register is empty.
[2] NAK	Send NAK Setting this bit sends a Not Acknowledge condition after the next byte of data has been received. It is automatically deasserted after the Not Acknowledge is sent or the IEN bit is cleared. If this bit is 1, it cannot be cleared to 0 by writing to the register.
[1] FLUSH	Flush Data Setting this bit clears the I ² C Data Register and sets the TDRE bit to 1. This bit allows flushing of the I ² C Data Register when an NAK condition is received after the next data byte is written to the I ² C Data Register. Reading this bit always returns 0.
[0] FILTEN	I²C Signal Filter Enable Setting this bit enables low-pass digital filters on the SDA and SCL input signals. This function provides the spike suppression filter required in I ² C Fast Mode. These filters reject any input pulse with periods less than a full system clock cycle. The filters introduce a 3-system clock cycle latency on the inputs.

16.3.4. I²C Baud Rate High and Low Byte Registers

The I²C Baud Rate High and Low Byte registers, shown in Tables 157 and 158, combine to form a 16-bit reload value, BRG[15:0], for the I²C Baud Rate Generator.

The I²C baud rate is calculated using the following equation.

$$\text{I}^2\text{C Baud Rate (bits/s)} = \frac{\text{System Clock Frequency (Hz)}}{4 \times \text{BRG}[15:0]}$$

When configured as a general purpose timer, the I²C baud rate generator interrupt interval is calculated using the following equation.

$$\text{I}^2\text{C Baud Rate (bits/s)} = \frac{\text{System Clock Frequency (Hz)}}{\text{BRG}[15:0]}$$

► **Note:** If BRG=0000h, then use 10000h in the equation.

Table 157. I²C Baud Rate High Byte Register (I2CBRH=53h)

Bit	7	6	5	4	3	2	1	0
Field	BRH							
Reset	1	1	1	1	1	1	1	1
R/W	R/W	R/W	R/W	R/W	R/W	R/W	R/W	R/W
Address	F53h							

Bit	Description
[7:0] BRH	I²C Baud Rate High Byte The most significant byte, BRG[15:8], of the I ² C Baud Rate Generator's reload value.

► **Note:** If the DIAG bit in the I²C Mode Register is set to 1, a read of the I2CBRH Register returns the current value of the I²C Baud Rate Counter[15:8].

Table 158. I²C Baud Rate Low Byte Register (I2CBRL=F54h)

Bit	7	6	5	4	3	2	1	0
Field	BRL							
Reset	1	1	1	1	1	1	1	1
R/W	R/W	R/W	R/W	R/W	R/W	R/W	R/W	R/W
Address	F54h							

Bit	Description
[7:0] BRL	I²C Baud Rate Low Byte The least significant byte, BRG[7:0], of the I ² C Baud Rate Generator's reload value.

► **Note:** If the DIAG bit in the I²C Mode Register is set to 1, a read of the I2CBRL Register returns the current value of the I²C Baud Rate Counter[7:0].

16.3.5. I²C State Register

The read-only I²C State Register, shown in Table 159, provides information about the state of the I²C bus and the I²C bus controller. When the DIAG bit of the I²C Mode Register is cleared, this register provides information about the internal state of the I²C controller and I²C bus; see Table 161.

When the DIAG bit of the I²C Mode Register is set, this register returns the value of the I²C controller state machine.

Table 159. I²C State Register (I2CSTATE), Description when DIAG=1

Bit	7	6	5	4	3	2	1	0
Field	I2CSTATE_H				I2CSTATE_L			
Reset	0	0	0	0	0	0	0	0
R/W	R	R	R	R	R	R	R	R
Address	F55h							

Bit	Description
[7:4] I2CSTATE_H	I²C State This field defines the current state of the I ² C controller. It is the most significant nibble of the internal state machine. Table 161 defines the states for this field.
[3:0] I2CSTATE_L	Least Significant Nibble of the I²C State Machine This field defines the substates for the states defined by I2CSTATE_H. Table 162 defines the values for this field.

Table 160. I²C State Register (I2CSTATE), Description when DIAG=0

Bit	7	6	5	4	3	2	1	0
Field	ACKV	ACK	AS	DS	10B	RSTR	SCLOUT	BUSY
Reset	0	0	0	0	0	0	1	0
R/W	R	R	R	R	R	R	R	R
Address	F55h							

Bit	Description
[7] ACKV	ACK Valid This bit is set, if sending data (master or slave) and the ACK bit in this register is valid for the byte just transmitted. This bit can be monitored if it is appropriate for software to verify the ACK value before writing the next byte to be sent. To operate in this mode, the Data Register must not be written when TDRE asserts; instead, the software waits for ACKV to assert. This bit clears when transmission of the next byte begins or the transaction is ended by a stop or restart condition.
[6] ACK	Acknowledge This bit indicates the status of the Acknowledge for the last byte transmitted or received. This bit is set for an Acknowledge and cleared for a Not Acknowledge condition.
[5] AS	Address State This bit is active High while the address is being transferred on the I ² C bus.
[4] DS	Data State This bit is active High while the data is being transferred on the I ² C bus.
[3] 10B	10B This bit indicates whether a 7-bit or 10-bit address is being transmitted when operating as a master. After the start bit is set, if the five most-significant bits of the address are 11110b, this bit is set. When set, it is Reset after the address has been sent.
[2] RSTR	Restart This bit is updated each time a stop or restart interrupt occurs (SPRS bit set in I2CISTAT Register). 0: Stop condition. 1: Restart condition.
[1] SCLOUT	Serial Clock Output Current value of Serial Clock being output onto the bus. The actual values of the SCL and SDA signals on the I ² C bus can be observed via the GPIO Input Register.
[0] BUSY	I²C Bus Busy 0: No activity on the I ² C Bus. 1: A transaction is underway on the I ² C bus.

Table 161. I2CSTATE_H

State Encoding	State Name	State Description
0000	Idle	I ² C bus is idle or I ² C controller is disabled.
0001	Slave Start	I ² C controller has received a start condition.
0010	Slave Bystander	Address did not match; ignore remainder of transaction.
0011	Slave Wait	Waiting for stop or restart condition after sending a Not Acknowledge instruction.
0100	Master Stop2	Master completing stop condition (SCL=1, SDA=1).
0101	Master Start/Restart	MASTER Mode sending start condition (SCL=1, SDA=0).
0110	Master Stop1	Master initiating stop condition (SCL=1, SDA=0).
0111	Master Wait	Master received a Not Acknowledge instruction, waiting for software to assert stop or start control bits.
1000	Slave Transmit Data	Nine substates, one for each data bit and one for the Acknowledge.
1001	Slave Receive Data	Nine substates, one for each data bit and one for the Acknowledge.
1010	Slave Receive Addr1	Slave receiving first address byte (7- and 10-bit addressing) Nine substates, one for each address bit and one for the Acknowledge.
1011	Slave Receive Addr2	Slave receiving second address byte (10-bit addressing) nine substates, one for each address bit and one for the Acknowledge.
1100	Master Transmit Data	Nine substates, one for each data bit and one for the Acknowledge.
1101	Master Receive Data	Nine substates, one for each data bit and one for the Acknowledge.
1110	Master Transmit Addr1	Master sending first address byte (7- and 10-bit addressing) nine substates, one for each address bit and one for the Acknowledge.
1111	Master Transmit Addr2	Master sending second address byte (10-bit addressing) nine substates, one for each address bit and one for the Acknowledge.

Table 162. I2CSTATE_L

State I2CSTATE_H	Substate I2CSTATE_L	Substate Name	State Description
0000–0100	0000	–	There are no substates for these I2CSTATE_H values.
0110–0111	0000	–	There are no substates for these I2CSTATE_H values.
0101	0000	Master Start	Initiating a new transaction
	0001	Master Restart	Master is ending one transaction and starting a new one without letting the bus go idle.

Table 162. I2CSTATE_L (Continued)

State I2CSTATE_H	Substate I2CSTATE_L	Substate Name	State Description
1000–1111	0111	Send/Receive bit 7	Sending/Receiving most significant bit.
	0110	Send/Receive bit 6	
	0101	Send/Receive bit 5	
	0100	Send/Receive bit 4	
	0011	Send/Receive bit 3	
	0010	Send/Receive bit 2	
	0001	Send/Receive bit 1	
	0000	Send/Receive bit 0	Sending/Receiving least significant bit.
	1000	Send/Receive Acknowledge	Sending/Receiving Acknowledge.

16.3.6. I²C Mode Register

The I²C Mode Register, shown in Table 163, provides control over master vs. slave operating mode, slave address and diagnostic modes.

Table 163. I²C Mode Register (I²C Mode=F56h)

Bit	7	6	5	4	3	2	1	0
Field	DMAIF	MODE[1:0]		IRM	GCE	SLA[9:8]		DIAG
Reset	0	0		0	0	0		0
R/W	R/W	R/W		R/W	R/W	R/W		R/W
Address	F56h							

Bit	Description
[7] DMAIF	DMAIF: DMA Interface Mode 0: Used when software polling or interrupts are used to move data. 1: Used when the DMA is used to move data. The TDRE and RDRF bits in the status register are not affected but the I ² C Interrupt is not asserted when TDRE or RDRF are set. The I ² C interrupt reflects only the error conditions. The assertion of TDRE causes a transmit DMA request. The assertion of RDRF causes a receive DMA request.
[6:5] MODE[1:0]	Selects the I²C Controller Operational Mode 00: MASTER/SLAVE capable (supports multi-master arbitration) with 7-bit slave address. 01: MASTER/SLAVE capable (supports multi-master arbitration) with 10-bit slave address. 10: Slave Only capable with 7-bit address. 11: Slave Only capable with 10-bit address.

Bit	Description (Continued)
[4] IRM	<p>Interactive Receive Mode</p> <p>Valid in SLAVE Mode when software must interpret each received byte before acknowledging. This bit is useful for processing the data bytes following a General Call Address or if software wants to disable hardware address recognition.</p> <p>0: Acknowledge occurs automatically and is determined by the value of the NAK bit of the I2CCTL Register.</p> <p>1: A receive interrupt is generated for each byte received (address or data). The SCL is held Low during the Acknowledge cycle until software writes to the I2CCTL Register. The value written to the NAK bit of the I2CCTL Register is output on SDA. This value allows software to Acknowledge or Not Acknowledge after interpreting the associated address/data byte.</p>
[3] GCE	<p>General Call Address Enable</p> <p>Enables reception of messages beginning with the General Call Address or start byte.</p> <p>0: Do not accept a message with the General Call Address or start byte.</p> <p>1: Do accept a message with the General Call Address or start byte. When an address match occurs, the GCA and RD bits in the I²C Status Register indicates whether the address matched the General Call Address/start byte or not. Following the General Call Address byte, the software can set the IRM bit that allows software to examine the following data byte(s) before acknowledging.</p>
[2:1] SLA[9:8]	<p>Slave Address Bits 9 and 8</p> <p>Initialize with the appropriate slave address value when using 10-bit slave addressing. These bits are ignored when using 7-bit slave addressing.</p>
[0] DIAG	<p>Diagnostic Mode</p> <p>Selects read back value of the Baud Rate Reload and State registers.</p> <p>0: Reading the baud rate registers returns the baud rate register values. Reading the state register returns I²C controller state information.</p> <p>1: Reading the Baud Rate registers returns the current value of the baud rate counter. Reading the state register returns additional state information.</p>

16.3.7. I²C Slave Address Register

The I²C Slave Address Register, shown in Table 164, provides control over the lower-order address bits used in 7- and 10-bit slave address recognition.

Table 164. I²C Slave Address Register (I2CSLVAD=57h)

Bit	7	6	5	4	3	2	1	0
Field	SLA[7:0]							
Reset	00h							
R/W	R/W							
Address	F57h							

Bit	Description
[7:0]	Slave Address Bits
SLA[7:0]	Initialize with the appropriate slave address value. When using 7-bit slave addressing, SLA[9:7] are ignored.

Chapter 17. Universal Serial Bus

The Z8 Encore! Universal Serial Bus (USB) Module provides USB full-speed device functionality with eight USB endpoints. It includes the following features:

- Full-speed (12Mbps) USB device
- IN endpoint 0 and OUT endpoint 0 control endpoints
- IN endpoints 1–3 and OUT endpoints 1–3 capable of bulk and interrupt transfers
- USB Suspend, host-initiated Resume, and device-initiated Resume (remote wake-up)
- USB clock of 48MHz from internal PLL or external clock source; see the [Clock System](#) chapter on page 96 to learn more
- 512 bytes of dedicated USB endpoint buffer memory; each endpoint buffer memory can be configured as 8, 16, 32, or 64 bytes
- Integrated full-speed USB PHY with integrated pull-up resistor
- Support for two DMA channels

17.1. Architecture

The architecture, shown in Figure 54, consists of a USB device, USB endpoint buffer memory, and a USB PHY.

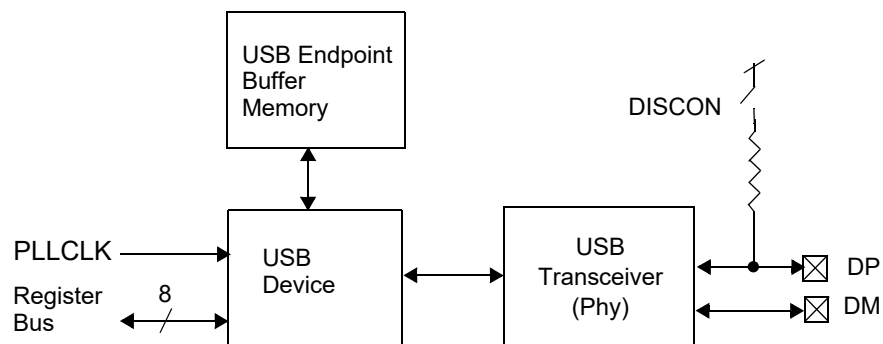

Figure 54. USB Block Diagram

17.2. Operation

The USB Module is a USB 2.0-compliant full-speed device with an integrated PHY and dedicated buffer memory space. The serial data rate for full-speed USB is 12Mbps. The USB Module performs serial-to-parallel conversion for received data and parallel-to-serial conversion for transmit.

USB data flow terminology is relative to the USB host. Data transmitted by the USB host is transmitted to a USB device OUT endpoint. Data to be sent to the USB host by a USB device is placed into a USB device IN endpoint buffer space prior to transmission. These endpoint buffer spaces can be accessed by software or by DMA.

The USB Module requires an accurate 48MHz clock, which can be supplied from the internal PLL or an external clock source, as described in the [Clock System](#) chapter on page 96.

17.2.1. Overview of USB Registers and Subregisters

Seven registers provide access to the USB Module: three registers for USB special functions (SFRs) and endpoint buffer memory, three registers for DMA control and data, and one register for resuming interrupt control. [Table 169](#) on page 356 lists these USB registers. The USB clock must be running to access the USB special function registers (SFRs) or endpoint buffer memory.

When ADDRSEL=0 in the USB Subaddress Register (USBSA), the USBSA provides address selection for subregisters in USB SFR address space. To access a USB Module SFR, write the USBSA Register with the appropriate SFR address, then read or write the USB Subdata Register (USBSD). When ADDRSEL=1 in the USBSA, the USBSA and the USB Control Register (USBCTL) together provide addressing for endpoint buffer memory. To access the USB Module endpoint buffer space, select an endpoint buffer with the USBCTL Register, write the USBSA Register with the appropriate address within the selected USB endpoint buffer space, then read or write the USBSD Register.

In addition, AI in the USBCTL Register controls autoincrementing of endpoint buffer memory accesses. Autoincrementing of endpoint memory buffer accesses is enabled if AI=0 and disabled if AI=1. Accesses to SFRs do not autoincrement.

The usage of the three DMA registers is described in the [DMA](#) section on page 355. The usage of the USB Interrupt Control Register is covered in the [Interrupts](#) section on page 355.

17.2.2. USB Endpoint Buffer Memory

The USB Module contains a dedicated 512-byte endpoint buffer space that provides up to 64 bytes of endpoint buffer memory for each endpoint. Data transmitted by the USB host is transmitted to a USB Module OUT endpoint buffer space. Data to be transmitted to the

USB host by the USB Module is placed in a USB Module IN endpoint buffer space prior to transmission. These endpoint buffer spaces can be accessed by software or by DMA.

Upon reset, the size of each endpoint buffer memory is configured to be 64 bytes. If it is desire that any endpoint buffer memory be less than 64 bytes, prior to enabling the USB, the size of each endpoint buffer memory must be configured.

OUT endpoint buffer memory sizes are used to derive the endpoint buffer memory allocation loaded into the USB0xADDR and USBISTADDR subregisters. IN endpoint buffer memory sizes are used to derive the endpoint buffer memory allocation loaded into the USB1xADDR and USBISPADDR subregisters. OUT endpoint 0 buffer memory starts at address 000h. USB0xADDR, USBISTADDR and USB1xADDR subregisters contain start address information for the other IN and OUT endpoints in buffer memory. The USBISPADDR Subregister contains the stop (upper) address for the highest number IN endpoint used. The size of an endpoint buffer space is a multiple of 2 bytes.

The equations to determine values for the endpoint buffer memory allocation subregisters are shown in Table 165. Endpoint buffer size is determined by subtracting consecutive values of endpoint start addresses, as shown in Table 165. If an OUT endpoint does not exist (or is not used), USB0xADDR should be cleared to 00h for that OUT endpoint. If an IN endpoint does not exist (or is not used), USB1xADDR should be cleared to 00h for that IN endpoint. Table 166 shows an example of endpoint buffer memory allocation when IN and OUT endpoints 3 are not used. Example register values are shown in Figure 55.

Endpoint buffer memory can be accessed using software as described in the [Overview of USB Registers and Subregisters](#) section on page 341 or using DMA as described in the [DMA](#) section on page 355.

Table 165. Determining USB Endpoint Buffer Memory Allocation with All Endpoints Used

Subregister	Subregister Value	Endpoint Buffer Size (Bytes)
USB01ADDR	OUT_EP0_SIZE ÷ 2	OUT_EP0_SIZE = 2 * USB01ADDR
USB02ADDR	USB01ADDR + (OUT_EP1_SIZE ÷ 2)	OUT_EP1_SIZE = 2 * (USB02ADDR - USB01ADDR)
USB03ADDR	USB02ADDR + (OUT_EP2_SIZE ÷ 2)	OUT_EP2_SIZE = 2 * (USB03ADDR - USB02ADDR)
USBISTADDR	(USB03ADDR + (OUT_EP3_SIZE ÷ 2)) ÷ 2	OUT_EP3_SIZE = 2 * ((2 * USBISTADDR) - USB03ADDR)
USB11ADDR	IN_EP0_SIZE ÷ 2	IN_EP0_SIZE = 2 * USB11ADDR
USB12ADDR	USB11ADDR + (IN_EP1_SIZE ÷ 2)	IN_EP1_SIZE = 2 * (USB12ADDR - USB11ADDR)
USB13ADDR	USB12ADDR + (IN_EP2_SIZE ÷ 2)	IN_EP2_SIZE = 2 * (USB13ADDR - USB12ADDR)
USBISPADDR	((USB13ADDR + (IN_EP3_SIZE ÷ 2)) ÷ 8) + (USBISTADDR ÷ 4)	IN_EP3_SIZE = 2 * ((8 * USBISPADDR) - USB13ADDR - (2 * USBISTADDR))

Table 166. Determining USB Endpoint Buffer Memory Allocation with Only Endpoints 0, 1 and 2 Used

Subregister	Subregister Value	Endpoint Buffer Size (Bytes)
USBO1ADDR	$\text{OUT_EP0_SIZE} \div 2$	$\text{OUT_EP0_SIZE} = 2 * \text{USBO1ADDR}$
USBO2ADDR	$\text{USBO1ADDR} + (\text{OUT_EP1_SIZE} \div 2)$	$\text{OUT_EP1_SIZE} = 2 * (\text{USBO2ADDR} - \text{USBO1ADDR})$
USBO3ADDR	00h	$\text{OUT_EP2_SIZE} = 2 * ((2 * \text{USBISTADDR}) - \text{USBO2ADDR})$
USBISTADDR	$(\text{USBO2ADDR} + (\text{OUT_EP2_SIZE} \div 2)) \div 2$	$\text{OUT_EP3_SIZE} = \text{n/a}$
USBI1ADDR	$\text{IN_EP0_SIZE} \div 2$	$\text{IN_EP0_SIZE} = 2 * \text{USBI1ADDR}$
USBI2ADDR	$\text{USBI1ADDR} + (\text{IN_EP1_SIZE} \div 2)$	$\text{IN_EP1_SIZE} = 2 * (\text{USBI2ADDR} - \text{USBI1ADDR})$
USBI3ADDR	00h	$\text{IN_EP2_SIZE} = 2 * ((8 * \text{USBISPADDR}) - \text{USBI2ADDR})$
USBISPADDR	$((\text{USBI2ADDR} + (\text{IN_EP2_SIZE} \div 2)) \div 8) + (\text{USBISTADDR} \div 4)$	$\text{IN_EP3_SIZE} = \text{n/a}$

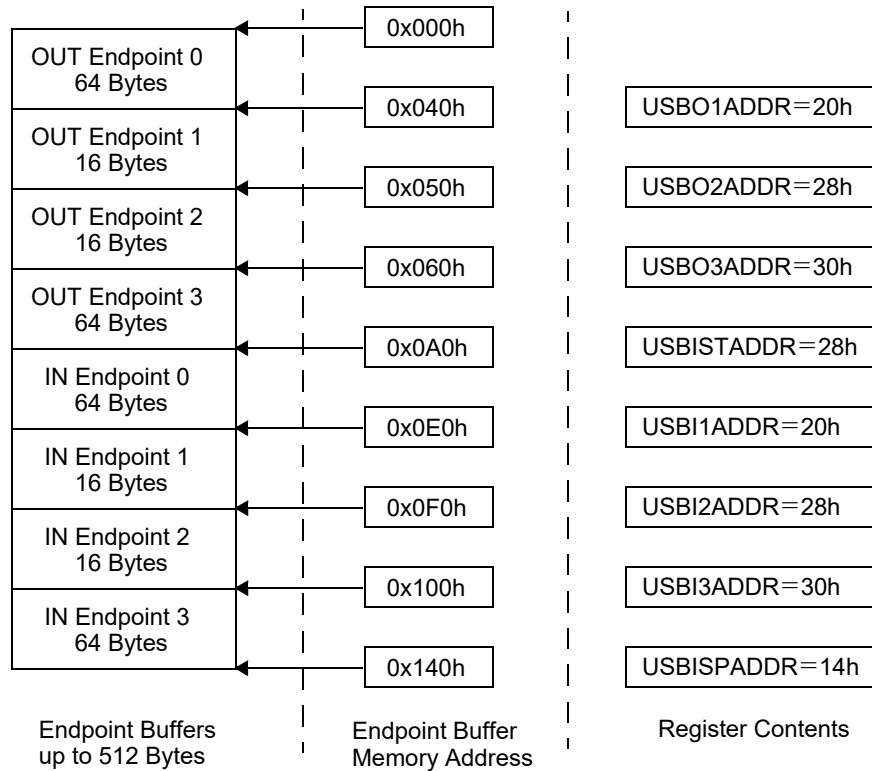

Figure 55. Example Endpoint Buffer Memory Allocation

17.2.3. USB Module Setup

After system reset, the DISCON bit in the USB Control and Status Subregister (USBCS) is set, thereby disconnecting the USB Module internal pull-up termination resistor from the USB bus. If using an external pull-up termination resistor, allow DISCON to remain set. If using the internal pull-up termination resistor, Zilog recommends setting up the USB Module prior to connecting the internal pull-up termination resistor by clearing DISCON. In addition to configuring endpoint buffer memory, as described in the [USB Endpoint Buffer Memory](#) section on page 341, additional USB Module setup should be performed, as described in the following sections.

17.2.3.1. Setting Valid Endpoints

To enable IN endpoints for normal operation, set the appropriate IN endpoint valid bits, INxVAL, in the USB IN Endpoint Valid Subregister (USBINVAL). To enable OUT endpoints for normal operation, set the appropriate out endpoint valid bits, OUTxVAL, in the USB OUT Endpoint Valid Subregister (USBOUTVAL).

17.2.4. USB Control Transfers Using Endpoint 0

A control transfer consists of two or three stages:

- Setup stage
- Data stage (optional)
- Status stage

The following describes control write and control read transfers, in addition to the associated status and interrupt bit.

17.2.4.1. Control Write

In the Setup stage of a control transfer, after receiving a Setup token, the USB Module sets the HSNACK bit in the USB Endpoint 0 Control and Status Subregister (USBEP0CS) and the SUTOKIRQ bit in the USB Protocol Interrupt Request Subregister (USBIRQ). A USB interrupt is generated if the SUTOKIEN bit is set in the USB Protocol Interrupt Enable Subregister (USBIEN). Subsequently, if an 8-byte data packet is received correctly, the USB Module sets the SUDAVIRQ bit in the USBIRQ Subregister and a USB interrupt is generated if the SUDAVIEN bit is set in the USBIEN Subregister. The 8-byte data packet can be accessed from the USB Setup Buffer Byte 0–7 subregisters (USBSUx), as described in the [Setup Buffer](#) section on page 347.

The Data stage of a control transfer consists of one or more OUT bulk-like transactions. After each correct OUT packet is received during the Data stage, the USB Module sets the OUT0IRQ bit in the USB OUT Interrupt Request Subregister (USBOUTIRQ), and a USB interrupt is generated if the OUT0IEN is set in the USB OUT Interrupt Enable Subregister (USBOUTIEN). The OUT0BC Subregister contains the number of data bytes received in the last OUT transaction. Software should service the interrupt request, then prepare the endpoint for the next transaction by reloading the OUT0BC Subregister with any value, which results in hardware setting the OUTBUSY bit in the USBEP0CS Subregister. Until this preparation task is performed, the USB Controller will NAK subsequent data packets.

The Status stage of a control transfer is the final operation in the sequence. Software should clear the HSNACK bit (by writing a 1 to it) to instruct the USB Module to ACK the Status stage. The USB Module sends the STALL handshake when both HSNACK and STALL bits are set. Prior to the Status stage, after the last successful transaction in the Data stage when all expected bytes of the transfer have been received or sent by the USB Module and a STALL handshake is to be sent for any additional data stage tokens, DSTALL is typically set by software. When DSTALL is set, the USB Module will send a STALL handshake if additional data stage tokens are sent and, if this transmission occurs, the STALL bit will be automatically set so that the USB Module will send a STALL handshake in the Status stage. If DSTALL is set, a token that indicates a transition to the status stage (e.g., an OUT token for an IN endpoint) will not cause a STALL handshake.

A control write transfer example is shown in Figure 56.

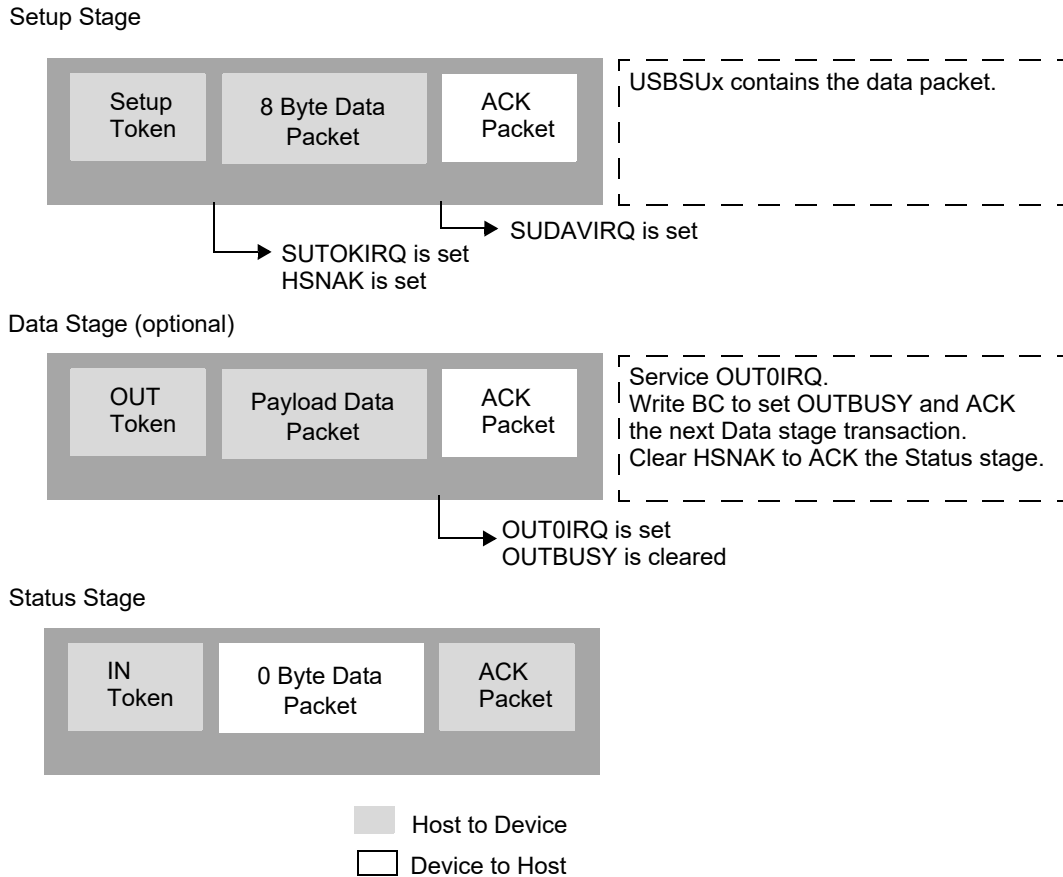

Figure 56. Control Write Transfer Example

17.2.4.2. Control Read

Control read transfer is similar to control write transfer. The difference is in the Data stage. During the Data stage of a control read transfer, after each acknowledge by the host, the USB Module sets the IN endpoint 0 interrupt request bit, IN0IRQ, in the USB IN Interrupt Request Subregister (USBINIRQ) and generates a USB interrupt if INxIEN is set in the USB IN Interrupt Enable Subregister (USBINIEN). Software should load new data into the IN endpoint 0 buffer memory and then reload the IN0BC Subregister with the number of data bytes loaded. Reloading the IN0BC Subregister causes the INBUSY bit to be set in the USBEP0CS Subregister and arms the endpoint for the next IN transaction. For the first data transaction after the setup transaction, software should arm IN endpoint 0 buffer memory based upon the Setup stage transaction. The Status stage of a control transfer is the final operation in the sequence. Software should clear the HSNAK bit (by writing a 1

to it) to instruct the USB Module to ACK the Status stage. The USB Module sends the STALL handshake when both HSNACK and STALL bits are set.

Some control transfers do not have a Data stage. In this case, the Status stage consists of the IN data packet. Software should clear the HSNACK bit (by writing a 1 to it) to instruct the USB Module to the ACK the Status stage. A control read transfer example is shown in Figure 57.

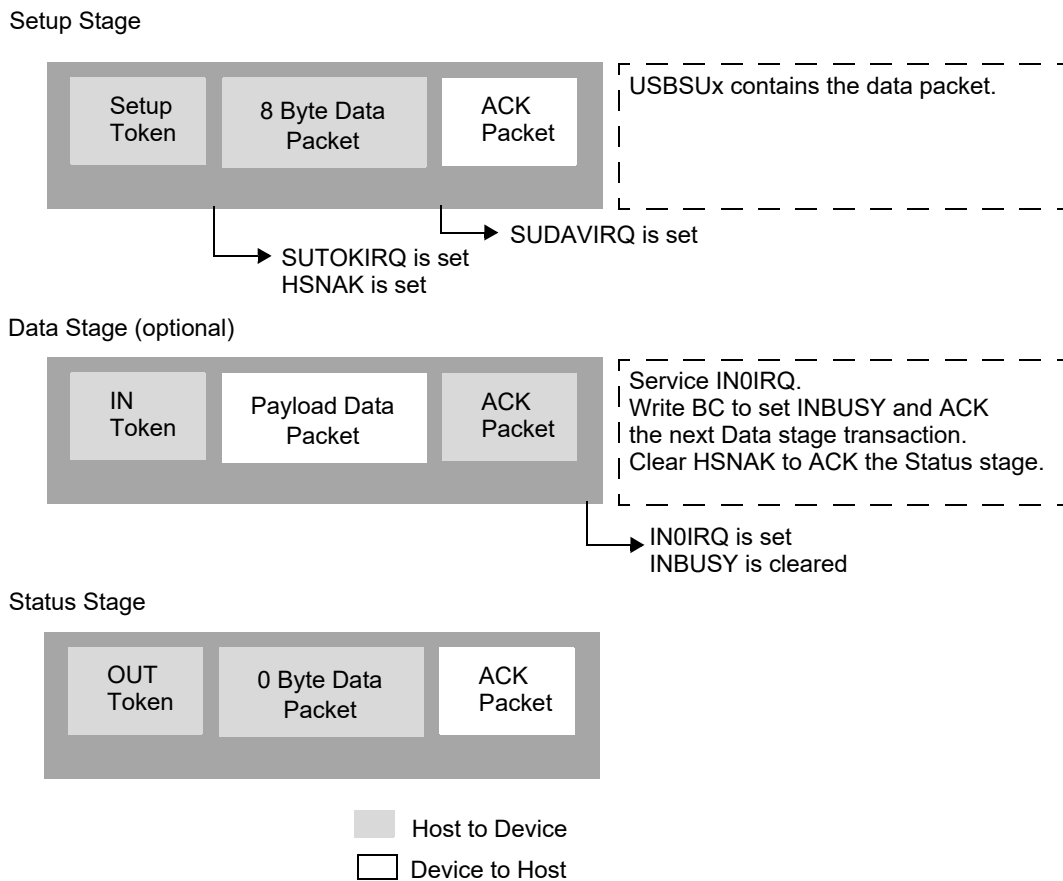

Figure 57. Control Read Transfer Example

17.2.4.3. Setup Buffer

During the Setup stage of a control transfer, the 8-byte data packet that follows the Setup token is written to the USB Setup Byte 0–7 subregisters (USBSUx). CHGSET in the USB Endpoint 0 Control and Status Subregister (USBEP0CS) is automatically set when the USB Module receives a setup data packet. Software clears CHGSET by writing a 1 to it. Software should access the USBSUx subregisters and identify and respond to the request.

The SET_ADDRESS control request is handled by the USB Module hardware. Software can ignore SET_ADDRESS requests. Other control requests should be handled by software.

17.2.5. USB Transfers Using Endpoints 1–3

Endpoints 1–3 are capable of bulk and interrupt transfers. For the sake of simplicity, the following discussion specifies bulk transfers, but pertains to both bulk and interrupt transfers. Each bulk transfer is composed of one or more data transactions. Each data transaction consist of two or three phases: token packet, data packet and optional handshake packet. In the following discussion, $x = 1-3$.

17.2.5.1. Bulk IN Transfers

When the host wishes to receive bulk data, it issues an IN token. If the INBUSY bit is set in the USB IN x Control and Status Subregister (USBIN x CS), the USB Module will respond by returning a data packet. If the host receives a valid data packet, it will respond with an ACK handshake. After receiving a valid ACK handshake from the host, the USB Module sets the IN x IRQ bit in the USB IN Interrupt Request Subregister (USBIN x IRQ) and clears the INBUSY bit in the USBIN x CS Subregister. Setting the IN x IRQ bit generates a USB interrupt request for the IN x endpoint if IN x IEN is set in the USB IN Interrupt Enable Subregister (USBIN x IEN). Software should service the interrupt request by loading new data into the IN endpoint x buffer memory and then write BC in the USB IN x Byte Count Subregister (USBIN x BC) with the corresponding number of data bytes. Writing USBIN x BC sets the INBUSY bit and arms the IN endpoint x for the next bulk data transfer.

When the INBUSY bit is set, the USB Module returns a data packet for each IN token from the host, as shown in Figure 58. When the INBUSY bit is not set, the USB Module returns the NAK handshake for each IN token from the host. When the INSTALL bit is set in the USBIN x CS Subregister, the USB Module returns a STALL handshake. Table 167 details the USB Module response to the host upon receiving an IN token.

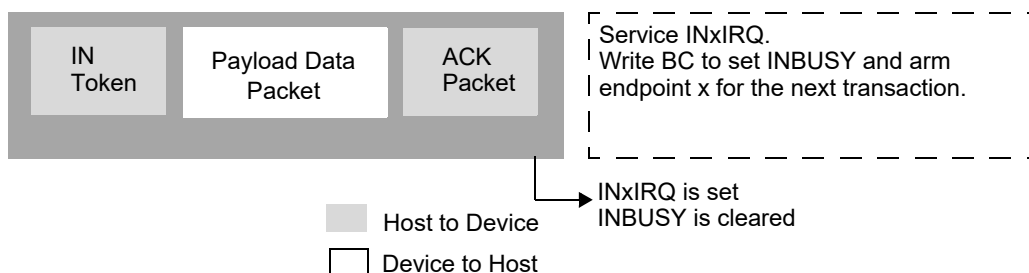

Figure 58. Bulk IN Transfer Example

Table 167. USB Module Response to Host upon Receiving an IN Token

Error in IN Token	INBUSY	INSTALL	USB Module Response to Host
No	0	0	NAK
No	0	1	STALL
No	1	0	BC (USB _I xBC Subregister) bytes data packet
No	1	1	STALL
Yes	–	–	No Response

17.2.5.2. Bulk OUT Transfers

When the host wishes to transmit bulk data, it issues an OUT token packet followed by a data packet. When the USB Module receives error-free OUT and data packets and the OUTBUSY bit is set in the USB OUT x Control and Status Subregister (USBOUTxCS), the USB Module returns an ACK handshake to the host and sets the OUTxIRQ bit in the USB OUT Interrupt Request Subregister (USBOUTIRQ). Setting the OUTxIRQ bit generates a USB interrupt request for the OUT endpoint x if OUTxIEN is set in the USB OUT Interrupt Enable Subregister (USBOUTIEN). Software should service the OUT x interrupt request by reading the received data packet that is available in the OUT endpoint x buffer space. After servicing the interrupt request, software should write BC in the USB OUT x Byte Count Subregister (USBOUTxBC) with any value. Writing USBOUTxBC sets the OUTBUSY bit, which arms the OUT endpoint x for the next OUT transfer. To regain control of endpoint x buffer memory space, software can clear the OUTBUSY bit by writing a 1 to it. It is recommended to wait one transaction period time for any in progress OUT transaction to complete (45us for full-speed USB).

When the USB Module receives an error-free OUT and data packets and the OUTBUSY bit is set, it will return an ACK handshake to the host, as shown in Figure 59. When the USB Module receives an error-free OUT and data packets but the OUTBUSY bit is not set, it will return a NAK handshake to the host. When the USB Module receives error-free OUT and data packets and the OUTSTALL bit is set in the USBOUTxCS Subregister, the USB Module will return a STALL handshake to the host. If any transmission error occurs during an OUT token or data phase, the USB Module will not return a handshake.

Table 168 details the USB Module response to the host upon receiving an OUT token.



Caution: .Software should not access USB buffer memory space when any buffer has been allocated to the USB Module. Before accessing USB buffer memory space, software should clear all OUTBUSY bits and wait one transaction period time for any in progress OUT transaction to complete (45us for full-speed USB). In addition, software should check that all INBUSY bits are cleared.

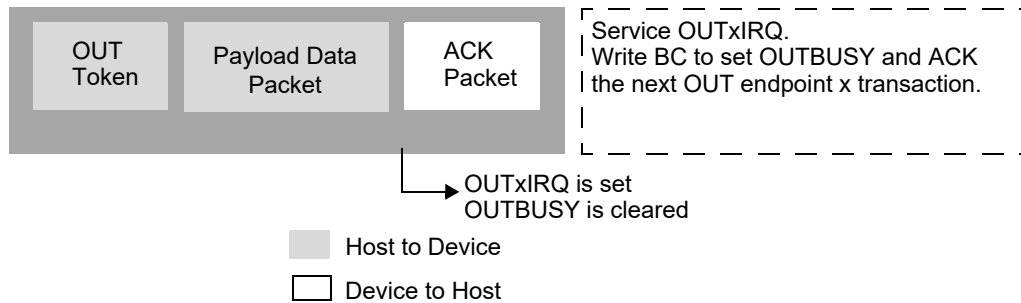

Figure 59. Bulk OUT Transfer Example

Table 168. USB Module Response to Host upon Receiving an OUT Token

Error in OUT Token	OUTBUSY	OUTSTALL	USB Module Response to Host
No	0	0	NAK
No	0	1	STALL
No	1	0	ACK
No	1	1	STALL
Yes	–	–	No Response

17.2.5.3. Function Address

The USB Module copies the function address which was sent by the host into the USB Function Address Subregister (FNADDR). Upon reset, the USB Module function address is cleared to be the default address of 00h, and this address is used until completing a SET_ADDRESS request from the host. The USB Module responds only when the packet function address matches the function address assigned to the USB Module.

17.2.6. Endpoint Pairing

Endpoints 2 and 3 may be paired to allow double buffering. When pairing is enabled, software may access one endpoint memory buffer of the pair while the USB host accesses the other buffer via the USB Module.

IN endpoints 2 and 3 are paired by setting PRIN23 in the USBPAIR Subregister. When IN endpoints 2 and 3 are paired, the IN endpoint 2 subregisters govern control of the paired endpoints; software should access only the IN endpoint 2 buffer space. The USB Module manages readdressing, as required, to utilize the IN endpoint 3 buffer space. Software is not required to configure the IN endpoint 3 control bits and registers. When paired, soft-

ware should not access the IN endpoint 3 buffer space, the IN3VAL bit, the IN3IEN bit, the IN3IRQ bit, the USBI3BC Subregister, or the USB3ICS Subregister.

To begin arming the paired IN endpoints, load the IN endpoint 2 buffer memory space twice. After each load is completed, write the number of bytes loaded to the USBI2BC Subregister to arm the endpoint buffer space. The USB Module readdresses the second IN endpoint 2 buffer memory load to IN endpoint 3 buffer memory. After the second write to the USBI2BC Subregister, both endpoints of the pair are armed and the INBUSY bit in the USB IN 2 Control and Status Subregister (USBIN2CS) is set by hardware. Software should not load new data into the IN endpoint 2 buffer space while INBUSY is set. When one or both of the endpoint buffer spaces of the pair become empty (unarmed), the INBUSY bit is cleared by hardware, and software may fill the IN endpoint 2 buffer memory with new data and again load the USBI2BC Subregister to arm the endpoint for transmission. Clearing the INBUSY bit (by writing a 1 to it) causes both of the paired endpoints to unarm. A USB interrupt request is generated after each data packet is correctly sent, independent of the INBUSY bit in the USBIN2CS Subregister.

OUT endpoints 2 and 3 are paired by setting PROUT23 in the USBPAIR Subregister. When OUT endpoints 2 and 3 are paired, the OUT endpoint 2 subregisters govern control of the paired endpoints; software should access only the OUT endpoint 2 buffer space. The USB Module manages readdressing, as required, to utilize the OUT endpoint 3 buffer space. Software is not required to configure the OUT endpoint 3 control bits and registers. When paired, software should not access the OUT endpoint 3 buffer space, the OUT3VAL bit, the OUT3IEN bit, the OUT3IRQ bit, the USBO3BC Subregister, or the USBO3CS Subregister.

To arm the paired OUT endpoints, load the USBO2BC Subregister twice. After the second write to the USBO2BC Subregister, both endpoints of the pair are armed, and the OUTBUSY bit in the USB OUT 2 Control and Status Subregister (USBO2CS) is set by hardware. When both endpoint buffer spaces of the pair are empty and no data is available, the OUTBUSY bit is set by hardware. When one or both of the buffers contain valid data, the OUTBUSY bit is cleared by hardware. Clearing the OUTBUSY bit (by writing a 1 to it) causes both of the paired endpoints to unarm. A USB interrupt request is generated after each data packet is correctly received, independent of the OUTBUSY bit.

17.2.7. USB Transfer Control

The following sections provide USB transfer control information.

17.2.7.1. Toggle Control

Data packet synchronization is achieved via the use of a data sequence toggle bit for each endpoint, and for the DATA0/DATA1 Packet IDs (PIDs). The USB Module automatically toggles DATA0/DATA1 PIDs at every bulk transfer. Software can directly set or clear the data toggle bits using the USB Toggle Control Subregister (USBTGCTL). Software should clear these data toggle bits when the host issues CLEAR_FEATURE or SET_INTERFACE, or selects an alternate setting.

To read a current data toggle bit value, software should perform the following sequence:

1. Write the USBTOGCTL subaddress to the USBSA Register.
2. Write the USBTOGCTL Subregister EP and $\overline{\text{IN/OUT}}$ fields to select the desired endpoint while writing the remaining fields with zeroes.
3. Read the data toggle value, DATA, in the USBTOGCTL Subregister.

To write a data toggle bit, software should perform the following sequence:

1. Write the USBTOGCTL subaddress to the USBSA Register.
2. Write the USBTOGCTL Subregister EP and $\overline{\text{IN/OUT}}$ fields to select the desired endpoint while writing the remaining fields with zeroes.
3. Repeat the write to the USBTOGCTL Subregister. The value written should be the same as the previous write, with the exception that either TDATA1 should be configured to set the toggle data value to 1 or TDATA0 should be configured to clear the toggle data value to 0.

17.2.7.2. SOF and USB Frame Number

The USB Module copies the received frame count into the USB Frame Count Low and USB Frame Count High subregisters (USBFCL and USBFCH) at every start of frame (SOF). Upon SOF, the SOFIRQ bit is set in the USB Protocol Interrupt Request Subregister (USBIRQ), and a USB interrupt is generated if SOFIEN is set in the USB Protocol Interrupt Enable Subregister (USBIEN).

In addition, using an internal timer, the USB Module can detect when an SOF from the host was missed. PLL_{CLK} is the clock source for the internal timer. This feature is enabled by setting the SOFWDOG bit in the USB Control and Status Subregister (USBCS). If the SOF is missed, a USB interrupt is generated, and the SOFIRQ bit is set in the USB Protocol Interrupt Request Subregister (USBIRQ).

17.2.7.3. USB Reset Bus State

When the USB Reset bus state occurs, the USB Module reports the condition by setting the URESIRQ bit in the USBIRQ Subregister. A USB interrupt is generated if the URESIEN bit is set in the USBIEN Subregister. In addition, when a USB Reset bus state is detected, the function address in the USB Function Address Subregister (USBFNADDR) is reset to 00h by the USB Module.

17.2.8. Suspend/Resume

Suspend is a mechanism for reducing power consumption from the USB (i.e., devices powered via the USB) when there is no traffic. The host initiates a Suspend by idling the USB for at least 3 ms. The Suspend is then detected by the USB Module, which should go into a reduced-power Suspend state. While in the Suspend state, either a USB device (such

as the USB Module) or the USB host can cause a Resume by changing the bus state to non-idle, after which USB devices can power up.

17.2.8.1. Suspend

When the USB detects an idle condition on the bus that lasts for at least 3 ms, the SUSPIRQ bit is set in the USB Protocol Interrupt Request Subregister (USBIRQ), and a USB interrupt is generated if the SUSPIEN bit is set in the USB Protocol Interrupt Enable Subregister (USBIEN). When a Suspend is detected, the device should go into a reduced-power Suspend state. The following steps should be performed by software upon a USB interrupt due to a Suspend:

1. Read the USBIRQ Subregister to determine if the interrupt is due to the host signaling a Suspend.
2. Write any value to the USBCLKGATE Subregister to gate off the USB clock and power down the USB PHY.
3. *Optional:* Disable the USB clock source (e.g., the PLL) if it is not currently selected as the system clock.

17.2.8.2. Device-Initiated Resume (Remote Wake-Up)

The USB Module supports device-initiated Resume (i.e., remote wake-up). Software should verify if the device that initiated the Resume is allowed and enabled for the device prior to initiating a Resume. Two methods are available to perform a device-initiated Resume. To perform a device-initiated Resume using the USB Module to time the USB Idle state, observe the following procedure:

1. If it is not already running, configure the USB PLL for a 48MHz output frequency, then enable the PLL and wait until it is stable. See the [Clock System](#) chapter on page 96 to learn more.
2. Set the RIRQE bit in the USBIRQCTL Register to enable both device-initiated and host-initiated Resume interrupt requests. Additionally, set the WAKEUP bit to initiate a Resume.
3. The USB Module will count 0–5 ms and a USB Resume interrupt will be generated after timing 5 ms of continuous USB bus Idle state. In addition, the WAKEUP bit in the USBIRQCTL Register will be cleared by the USB Module.
4. Read the DEVRSUME bit in the USB Control and Status Subregister (USBCS) to determine if the Resume is device-initiated.
5. Set the SIGRSUME bit in the USB Control and Status Subregister (USBCS) to initiate remote wake-up signaling to the host. To raise the crossover voltage during remote wake-up signalling, software can first write the FORCEJ bit in the USB Control and Status Subregister (USBCS), then clear the FORCEJ bit and set the SIGRSUME bit.

6. Wait 1–15 ms, then clear the SIGRSUME bit.

To perform a device-initiated Resume using the software to time the USB Idle state, observe the following procedure:

1. Clear the RIRQE bit in the USBIRQCTL Register so that only a host-initiated Resume generates a USB Resume interrupt.
2. If it is not already running, configure the USB PLL for a 48MHz output frequency, then enable the PLL and wait until it is stable. See the [Clock System](#) chapter on page 96 to learn more.
3. Ensure that the USB bus has been continuously in the Idle state for a minimum of 5 ms, then set the WAKEUP bit in the USBIRQCTL Register to initiate a Resume.
4. Set the SIGRSUME bit in the USB Control and Status Subregister (USBCS) to initiate remote wake-up signaling to the host. To raise the crossover voltage during remote wake-up signalling by initially forcing the Data J bus state, software can first write to the FORCEJ bit in the USB Control and Status Subregister (USBCS), then clear the FORCEJ bit and set the SIGRSUME bit.
5. Wait 1–15 ms, then clear the SIGRSUME bit.
6. Clear the WAKEUP bit in the USBIRQCTL Register.

17.2.8.3. Host-Initiated Resume

While in the Suspend state and not performing a device-initiated Resume, the RIRQE bit in the USBIRQCTL Register should be cleared. When the USB host wishes to wake up a USB device, it drives the Data K bus state on the USB bus for 20ms. Upon detecting the Data K bus state, the USB Module generates a USB Resume interrupt. Software should perform the following steps to perform a host-initiated Resume:

- If it is not already running, configure the USB PLL for a 48MHz output frequency, then enable the PLL and wait until it is stable. See the [Clock System](#) chapter on page 96 to learn more.
- *Optional:* When the USB Module recognizes PLL_{CLK}, it will clear the DEVRSUME bit in the USB Control and Status Subregister (USBCS), which can be polled. If the RIRQE bit is set, another USB Resume interrupt request is generated; therefore, the RIRQE bit should be cleared during a host-initiated Resume.

17.2.9. Stop Mode Operation

Stop Mode should only be entered when the USB Controller is either:

- Not available on the F6482 Series part number being used
- Unused, as indicated by DISCON=1 in the USB Control and Status Subregister (USBCS)

- In the Standby State and no longer requires the USB clock

While in Stop Mode, the USB controller can receive Resume signalling from the host, and will assert the USB Resume interrupt request if Resume signalling is received.

17.2.10.USB Module Interrupts and DMA

The following sections describe the USB Module interrupts and DMA.

17.2.10.1.Interrupts

The USB Module provides two interrupt requests: the USB Resume interrupt request that signals USB Resume, and the USB interrupt request that signals all other USB interrupts.

While the RIRQE bit is cleared in the USBIRQCTL Register, the USB Resume interrupt is generated only upon host-initiated Resume. While the RIRQE bit is set, the USB Resume interrupt is generated upon both a host-initiated Resume and a device-initiated Resume. To learn more, see the [Suspend/Resume](#) section on page 352.

Each USB interrupt request source that shares the USB interrupt request is associated to an interrupt request bit in either the USBINIRQ, USBOUTIRQ or USBIRQ Subregister. Each interrupt request bit has a corresponding interrupt enable bit in the USBINIEN, USBOUTIEN, or USBIEN Subregister which determines whether a particular interrupt request source generates a USB interrupt request.

The current USB interrupt request source is furnished by the IID bit in the USB Interrupt Identification Subregister (USBIID). Because more than one USB interrupt request source can be active simultaneously, the contents of the IID bit are prioritized in the order listed in the description of the USB Interrupt Identification Subregister. To learn more, see the [USB Interrupt Identification Subregister](#) section on page 368.

17.2.10.2.DMA

The USB Module provides USB endpoint buffer memory access for up to two DMA channels. The two DMA channels can be independently configured to access any of the 4 IN or 4 OUT endpoints. In addition to the DMA control registers described in the [Direct Memory Access Controller](#) chapter on page 390, the USB Module contains two DMA control registers, USBDMA0CTL and USBDMA1CTL, each providing additional control for a single DMA channel.

Both DMA channels access endpoint buffer memory via the single USB DMA Data Register, USBDMADATA, using DMA fixed addressing. The USB Module performs autoincrementing of the endpoint buffer memory address, from 0 to 63, at each DMA access. This endpoint buffer memory address is reset to 0 when the USB asserts a DMA request. It is not possible to start a DMA transfer at an endpoint memory buffer address other than 0.

The USB DMA Control registers, USBDMA0CTL and USBDMA1CTL, are used to select which endpoint buffer memory is to be accessed by DMA and to initiate assertion of

the associated DMA request. The desired endpoint buffer space is selected using the EPSEL field in the USBDMA0CTL (or USBDMA1CTL) Register. A DMA request is asserted by setting the STARTDMA bit. When asserted, a DMA request will remain asserted until the DMA Controller transfers the last byte (based on the DMA count). A DMA request will also be deasserted if the DMA Controller attempts to transfer more than 64 bytes.

Software typically initiates a DMA transfer from an OUT endpoint following a USB interrupt to service the OUT endpoint buffer memory space indicated by OUTxIRQ in the USBOUTIRQ Subregister. Software reads the corresponding USB OUT x Byte Count Subregister (USBOxBC) containing the number of bytes to be transferred, and will configure the appropriate DMA x Count Subregister in the DMA Controller. In the DMA Controller, the DMA source address should be configured with the USBDMADATA Register address, and fixed-source addressing should be selected. Typically, the destination address is configured to be the Register RAM. Software then writes the USBDMA0CTL (or USBDMA1CTL) Register to select the endpoint buffer memory and initiate assertion of a DMA request.

Software typically initiates a DMA transfer to an IN endpoint buffer following a USB interrupt to service the IN endpoint indicated by INxIRQ in the USBINIRQ Subregister. The USBDMADATA Register address is the DMA destination address, and should be accessed with fixed addressing. When the next IN endpoint buffer data is available, software configures a DMA channel and writes to the USBDMA0CTL (or USBDMA1CTL) Register to select the appropriate IN endpoint and initiate assertion of a DMA request. When the DMA completes, software should write to the USBIBC Subregister to arm the USB IN endpoint.

17.3. USB Control Register Definitions

Seven registers provide access to the USB Module: three registers for USB special function registers (SFRs) and endpoint buffer memory, three registers for DMA control and data, and one register for interrupt control. Table 169 lists these USB registers. The USB Subaddress Register (USBSA), USB Subdata Register (USBSD), and USB Control Register (USBCTL) together provide access to the subregisters that control USB SFRs and endpoint buffer spaces.

Table 169. USB Registers and Subregisters

USB Register Mnemonic	Address	USB Register Name
USBSA	F59h	USB Subaddress Register
USBSD	F5Ah	USB Subdata Register
USBCTL	F5Bh	USB Control Register
USBDMA0CTL	F5Ch	USB DMA 0 Control Register

Note: *The DMASA bit in the DMASA Register contains the subregister address.

Table 169. USB Registers and Subregisters (Continued)

USBDMA1CTL	F5Dh	USB DMA 1 Control Register
USBDMA1DATA	F5Eh	USB DMA Data Register
USBIRQCTL	F5Fh	USB Interrupt Control Register
USB Subdata Register Mnemonic	Subregister Address*	USB Subdata Register Name
USBOxADDR	01h–03h	USB Out Endpoint 1–3 Start Address Subregister
USBISTADDR	08h	USB IN Endpoints Start Address Subregister
USBIxADDR	09h–0Bh	USB IN Endpoint 1–3 Start Address Subregister
USBCLKGATE	10h	USB Clock Gate Subregister
USBIID	28h	USB Interrupt Identification Subregister
USBINIRQ	29h	USB IN Interrupt Request Subregister
USBOUTIRQ	2Ah	USB OUT Interrupt Request Subregister
USBIRQ	2Bh	USB Protocol Interrupt Request Subregister
USBINIEN	2Ch	USB IN Interrupt Enable Subregister
USBOUTIEN	2Dh	USB OUT Interrupt Enable Subregister
USBIEN	2Eh	USB Protocol Interrupt Enable Subregister
USBEP0CS	34h	USB Endpoint 0 Control and Status Subregister
USBxBC	35h, 37h, 39h, 3Bh	USB IN 0–3 Byte Count Subregister
USBxCS	36h, 38h, 3Ah	USB IN 1–3 Control and Status Subregister
USBOxBC	45h, 47h, 49h, 4Bh	USB OUT 0–3 Byte Count Subregister
USBOxCS	46h, 48h, 4Ah	USB OUT 1–3 Control and Status Subregister
USBCS	56h	USB Control and Status Subregister
USBTGCTL	57h	USB Toggle Control Subregister
USBFCL	58h	USB Frame Count Low Subregister
USBFCH	59h	USB Frame Count High Subregister
USBFNADDR	5Bh	USB Function Address Subregister
USBPAIR	5Dh	USB Endpoint Pairing Subregister
USBINVAL	5Eh	USB IN Endpoint Valid Subregister
USBOUTVAL	5Fh	USB OUT Endpoint Valid Subregister
USBISPADDR	62h	USB IN Endpoints Stop Address Subregister
USBSUx	68h–6Fh	USB Setup Buffer Byte 0–7 Subregister

Note: *The DMASA bit in the DMASA Register contains the subregister address.

17.3.1. USB Subaddress Register

The USB Subaddress Register, shown in Table 170, together with AI and EPSEL in the USB Control Register (USBCTL; see Table 172), select the USB Module functionality accessible through the USB Subdata Register (USBSD) shown in Table 171. The USB

Subaddress Register, USB Control Register and USB Subdata Register combine to provide write access to all USB Module controls and buffer memory.

This register contains an address in the USB Module memory space selected by the USBCTL Register. For access to endpoint buffer spaces (64 bytes maximum each), bits 7 and 6 of this register are forced to 0 by hardware.

Table 170. USB Subaddress Register (USBSA)

Bit	7	6	5	4	3	2	1	0
Field	ADDRSEL	USBSA						
Reset	0	0	0	0	0	0	0	0
R/W	R/W	R/W1	R/W1	R/W	R/W	R/W1	W	R/W
Address	F59h							

Bit	Description
[7] ADDRSEL	Addressing Select 0: Special Function Register (SFR). 1: Endpoint buffer selected by EPSEL in the USBCTL Register.
[6:0] USBSA	USB Subaddress 00-7F: Selects the USB Subdata Register accessed when USBSD is written. When accessing endpoint buffer memories, if AI=0 in USBCTL, this register auto-increments whenever the USBSD is read (OUT endpoints) or written (IN endpoints) and wraps back to 0 at the address space boundary.

17.3.2. USB Subdata Register

The USB Subdata Register, shown in Table 171, sets the USB operation and transfers USB endpoint buffer memory data. The values ADDRSEL and USBSA in the USB Sub-address Register together with EPSEL in the USB Control Register determine which USB Subdata Register is read from or written to by a USB Subdata Register access. Whenever this register is accessed USBSA can be autoincremented as described in the [USB Subaddress Register](#) section on page 357.

Table 171. USB Subdata Register (USBSD)

Bit	7	6	5	4	3	2	1	0
Field	USBSD							
Reset	0	0	0	0	0	0	0	0
R/W	R/W	R/W1	R/W1	R/W	R/W	R/W1	W	R/W
Address	F5Ah							

Bit	Description
[7:0] USBSD	00–FF: USBSD is a portal providing access to all endpoint buffer memories and all subregisters that configure the USB operation as selected by the USBSA and USBCTL registers.

17.3.3. USB Control Register

The USB Control Register, shown in Table 172, selects the USB Module endpoint buffer memory addressing method and the endpoint buffer memory section for the USBSD access.

Table 172. USB Control Register (USBCTL)

Bit	7	6	5	4	3	2	1	0
Field	Reserved	AI	EPSEL			Reserved		
Reset	0	0	0	0	0	0	0	0
R/W	R	R/W	R/W	R/W	R/W	R	R	R
Address	F5Bh							

Bit	Description
[7]	Reserved This bit is reserved and must be programmed to 0.
[6] AI	Addressing Select 0: Accesses to the endpoint buffer selected by EPSEL will auto-increment. 1: Accesses to the endpoint buffer selected by EPSEL will not auto-increment.
[5:3] EPSEL	Endpoint Select 000: IN endpoint 0 buffer memory. 001: IN endpoint 1 buffer memory. 010: IN endpoint 2 buffer memory. 011: IN endpoint 3 buffer memory. 100: OUT endpoint 0 buffer memory. 101: OUT endpoint 1 buffer memory. 110: OUT endpoint 2 buffer memory. 111: OUT endpoint 3 buffer memory.
[2:0]	Reserved These bits are reserved and must be programmed to 000.

17.3.4. USB DMA 0–1 Control Registers

The USBDMAxCTL registers, shown in Table 173, control DMA accesses. Two independent DMA channels can service the USB.

Table 173. USB DMA 0–1 Control Registers (USBDMAxCTL)

Bit	7	6	5	4	3	2	1	0
Field	Reserved		EPSEL			Reserved		STARTDMA
Reset	0	0	0	0	0	0	0	0
R/W	R	R	R/W	R/W	R/W	R	R	R/W
Address	USBDMA0CTL @ F5Ch, USBDMA1CTL @ F5Dh							

Note: x references bits in the range [1:0].

Bit	Description
[7:6]	Reserved This bit is reserved and must be programmed to 00.
[5:3] EPSEL	End Point Buffer Select 000: IN endpoint 0 buffer memory. 001: IN endpoint 1 buffer memory. 010: IN endpoint 2 buffer memory. 011: IN endpoint 3 buffer memory. 100: OUT endpoint 0 buffer memory. 101: OUT endpoint 1 buffer memory. 110: OUT endpoint 2 buffer memory. 111: OUT endpoint 3 buffer memory.
[2:1]	Reserved This bit is reserved and must be programmed to 00.
[0] STARTDMA	Start DMA 0: DMA request is deasserted. 1: Start DMA by asserting DMA request. STARTDMA will be cleared by hardware when the DMA transfer completes. Software can also clear this bit to deassert DMA request.

17.3.5. USB DMA Data Register

The USBDMADATA Register, shown in Table 174, provides a portal for DMA 0–1 accesses to and from the endpoint buffer spaces. Both DMA channels can be enabled simultaneously and access this register without conflict.

When DMA is started, byte 0 of the endpoint buffer memory is accessed (read or written) first. Upon each access, an internal address pointer will autoincrement selecting the next endpoint buffer memory byte. Modulo-64 counting is performed such the internal address pointer will point to the first byte after 64th byte is accessed.

Table 174. USB DMA Data Register (USBDMADATA)

Bit	7	6	5	4	3	2	1	0
Field	DMADATA							
Reset	0	0	0	0	0	0	0	0
R/W	R/W	R/W1	R/W1	R/W	R/W	R/W1	W	R/W
Address	F5Eh							

Bit	Description
[7:0]	DMA Data
DMADATA	00–FF: DMA data value for the currently addressed endpoint buffer memory location.

17.3.6. USB Interrupt Control Register

The USBIRQCTL Register, shown in Table 175, is used to perform a device-initiated Resume and to manage Resume interrupts.

Table 175. USB Interrupt Control Register (USBIRQCTL)

Bit	7	6	5	4	3	2	1	0
Field	Reserved						RIRQE	WAKEUP
Reset	0	0	0	0	0	0	0	0
R/W	R	R	R	R	R	R	R/W	R/W
Address	F5Fh							

Bit	Description
[7:2]	Reserved These bits are reserved and must be programmed to 000000.
[1] RIRQE	Resume Interrupt Request Enable 0: Interrupt only for host-initiated resume. PLLCLK does not need to be running for a host-initiated resume interrupt to occur. 1: Interrupt for both host-initiated resume and device-initiated resume that is using the USB to time Idle state duration. For the latter, the USB resume interrupt is generated once the USB has completed timing the Idle state. See Suspend/Resume on page 352 for details.
[0] WAKEUP	Wake-Up (Device-Initiated Resume) 0: Do not perform a device-initiated resume. 1: Start a device-initiated resume. When using the USB Controller to time the USB Idle state, RIRQE should also be set if WAKEUP is set. If using the USB to time the USB Idle state, WAKEUP is cleared by the USB Controller when it is waking up and the USB clock is running. See device-initiated resume (Remote Wake-up) on page 362 for details.

17.3.7. USB OUT Endpoint 1–3 Start Address Subregisters

The USB OUT 1–3 Start Address subregisters, shown in Table 176, in conjunction with the USBISTADDR Register shown in Table 177, define the size of each OUT endpoint.

Table 176. USB OUT Endpoint 1–3 Start Address Subregisters (USBOxADDR)

Bit	7	6	5	4	3	2	1	0
Field	OUTADDR							
Reset	see below description							
R/W	R0/W*	R0/W*	R0/W*	R0/W*	R0/W*	R0/W*	R0/W*	R0/W*
Address	If USBSA = 01h, 02h, 03h in the USB Subaddress Register, it is accessible through the USB Subdata Register							
Note: *R0/W = Write but reads back as 0.								

Bit	Description
[7:0] OUTADDR	<p>OUT Endpoint Start Address</p> <p>00–FF: The start address of OUT endpoint memory buffers except OUT endpoint 0. The first starting address (OUT endpoint 0) is fixed at buffer memory address 000h. {0, OUTADDR[7:0], 0} maps to buffer memory address [9:0]; therefore the minimum increment of OUTADDR is 2 bytes of buffer memory. The size in bytes of an OUT endpoint is determined by subtracting consecutive starting address values then multiplying by 2. OUTADDR should be set to 00h for any OUT endpoint that doesn't exist (or is not used). See USB Endpoint Buffer Memory on page 341 for details.</p> <p>Reset State: USBO1ADDR: 20h USBO2ADDR: 40h USBO3ADDR: 60h</p>

17.3.8. USB IN Endpoints Start Address Subregister

The USB IN Endpoints Start Address Subregister, shown in Table 177 defines the starting address for IN endpoints and stop address for the uppermost OUT endpoint.

Table 177. USB IN Endpoints Start Address Subregister (USBISTADDR)

Bit	7	6	5	4	3	2	1	0
Field	Reserved	INSTADDR						
Reset	0	0	0	0	0	1	0	0
R/W	R0/W*	R0/W*	R0/W*	R0/W*	R0/W*	R0/W*	R0/W*	R0/W*
Address	If USBSA = 08h in the USB Subaddress Register, accessible through the USB Subdata Register							
Note: *R0/W = Write but reads back as 0								

Bit	Description
[7]	Reserved This bit is reserved and must be programmed to 0.
[6:0] INSTADDR	IN Start Address 00–7F: The starting address for IN endpoints. The first IN starting address (IN endpoint 0) is determined by INSTADDR. {INSTADDR[7:0], 0, 0} maps to endpoint buffer memory address [9:0]; therefore the minimum increment of INSTADDR is 4 bytes of buffer memory. Also, $2 \times (2 \times \text{INSTADDR} \text{ minus the uppermost OUTADDR})$ determines the size in bytes of the uppermost OUT endpoint buffer memory. See the USB Endpoint Buffer Memory section on page 341 for details.

17.3.9. USB IN Endpoint 1–3 Start Address Subregisters

The USB IN Endpoint 1–3 Start Address subregisters, shown in Table 178, in conjunction with the USBISTADDR Register shown in Table 177 and the USBISPADDR Register shown in [Table 200](#) on page 388, define the size of each IN endpoint.

Table 178. USB IN Endpoint 1–3 Start Address Subregisters (USBIXADDR)

Bit	7	6	5	4	3	2	1	0
Field	INADDR							
Reset	see description below							
R/W	R0/W*	R0/W*	R0/W*	R0/W*	R0/W*	R0/W*	R0/W*	R0/W*
Address	If USBSA = 09h, 0Ah, 0Bh in the USB Subaddress Register, accessible through the USB Subdata Register							
Note: *R0/W = Write, but reads back as 0.								

Bit	Description
[7:0]	IN Endpoint Start Address
INADDR	00–FF: The start address of IN endpoint memory buffers except IN endpoint 0. The first starting address (IN endpoint 0) is configured in the USBISTADDR Register. INSTADDR + {0, INADDR[7:0], 0} maps to endpoint buffer memory address [9:0], therefore the minimum increment of INADDR is 2 bytes of buffer memory. The size in bytes of an IN endpoint is determined by subtracting consecutive starting address values then multiplying by 2. INADDR should be set to 00h for any IN endpoint that doesn't exist (or is not used). See the USB Endpoint Buffer Memory section on page 341 for details. Reset State: USBI1ADDR: 20h USBI2ADDR: 40h USBI3ADDR: 60h

17.3.10. USB Clock Gate Subregister

The USB Clock Gate Subregister, shown in Table 179, is used to disable the USB clock. Writing any value to the USBCLKGATE Register disables the USB Module clock. The USBCLKGATE Register is a write-only register.

Table 179. USB Clock Gate Subregister (USBCLKGATE)

Bit	7	6	5	4	3	2	1	0
Field	CLKGATE							
Reset	0	0	0	0	0	0	0	0
R/W	R0/W*	R0/W*	R0/W*	R0/W*	R0/W*	R0/W*	R0/W*	R0/W*
Address	If USBSA = 10h in the USB Subaddress Register, accessible through the USB Subdata Register							
Note: *R0/W = Write, but reads back as 0.								

Bit	Description
[7:0]	Clock Gate
CLKGATE	00–FF: Writing any value to the USBCLKGATE Register disables the USB Module clock to suspend the USB Module.



17.3.11. USB Interrupt Identification Subregister

The USB Interrupt Identification Subregister, shown in Table 180, contains the USB Module interrupt identifier. When the USB Module generates a USB interrupt request, the USBIID Subregister is updated to indicate the source of the interrupt. If more than one USB interrupt request is asserted, the contents of IID reflect the highest priority interrupt based on the order listed in the IID description. To learn more, see the [Interrupts](#) section on page 355.

Table 180. USB Interrupt Identification Subregister (USBIID)

Bit	7	6	5	4	3	2	1	0	
Field	Reserved	IID						Reserved	
Reset	0	0	0	0	0	0	0	0	
R/W	R	R	R	R	R	R	R	R	
Address	If USBSA = 28h in the USB Subaddress Register, accessible through the USB Subdata Register								

Bit	Description
[7]	Reserved This bit is reserved and must be programmed to 0.
[6:2] IID	Interrupt Identification (Source) 00000: SUDAVIRQ in the USBIRQ Register. Highest priority. 00001: SOFIRQ in the USBIRQ Register. 00010: SUTOKIRQ in the USBIRQ Register. 00011: SUSPIRQ in the USBIRQ Register. 00100: URESIRQ in the USBIRQ Register. 00101: Reserved. 00110: IN0IRQ in the USBINIRQ Register. 00111: OUT0IRQ in the USBOUTIRQ Register. 01000: IN1IRQ in the USBINIRQ Register. 01001: OUT1IRQ in the USBOUTIRQ Register. 01010: IN2IRQ in the USBINIRQ Register. 01011: OUT2IRQ in the USBOUTIRQ Register. 01100: IN3IRQ in the USBINIRQ Register. 01101: OUT3IRQ in the USBOUTIRQ Register. Lowest priority. Others: Reserved.
[1:0]	Reserved These bits are reserved and must be programmed to 00.

17.3.12. USB IN Interrupt Request Subregister

The USB IN Interrupt Request Subregister, shown in Table 181, indicates the IN endpoint interrupt requests. The USB Module sets INxIRQ when it transmits an IN endpoint x data packet and receives an ACK from the host. The interrupt is cleared by writing a 1 to the corresponding register position.

Table 181. USB IN Interrupt Request Subregister (USBINIRQ)

Bit	7	6	5	4	3	2	1	0
Field	Reserved				IN3IRQ	IN2IRQ	IN1IRQ	IN0IRQ
Reset	0	0	0	0	0	0	0	0
R/W	R	R	R	R	R/W1*	R/W1*	R/W1*	R/W1*
Address	If USBSA = 29h in the USB Subaddress Register, accessible through the USB Subdata Register							
Note: *R/W1 = Writing a 1 clears this bit.								

Bit	Description
[7:4]	Reserved These bits are reserved and must be programmed to 0000.
[3] IN3IRQ	IN Endpoint 3 Interrupt Request 0: No interrupt request from IN endpoint 3. 1: Interrupt request from IN endpoint 3.
[2] IN2IRQ	IN Endpoint 2 Interrupt Request 0: No interrupt request from IN endpoint 2. 1: Interrupt request from IN endpoint 2.
[1] IN1IRQ	IN Endpoint 1 Interrupt Request 0: No interrupt request from IN endpoint 1. 1: Interrupt request from IN endpoint 1.
[0] IN0IRQ	IN Endpoint 0 Interrupt Request 0: No interrupt request from IN endpoint 0. 1: Interrupt request from IN endpoint 0.

17.3.13. USB OUT Interrupt Request Subregister

The USB OUT Interrupt Request Subregister, shown in Table 182, indicates the OUT endpoint interrupt requests. The USB Module sets OUTxIRQ when it receives an error free OUT endpoint x data packet. The interrupt is cleared by writing a 1 to the corresponding register position.

Table 182. USB OUT Interrupt Request Subregister (USBOUTIRQ)

Bit	7	6	5	4	3	2	1	0
Field	Reserved				OUT3IRQ	OUT2IRQ	OUT1IRQ	OUT0IRQ
Reset	0	0	0	0	0	0	0	0
R/W	R	R	R	R	R/W1*	R/W1*	R/W1*	R/W1*
Address	If USBSA = 2Ah in the USB Subaddress Register, accessible through the USB Subdata Register							

Note: *R/W1 = Writing a 1 clears this bit.

Bit	Description
[7:4]	Reserved These bits are reserved and must be programmed to 0000.
[3] OUT3IRQ	OUT Endpoint 3 Interrupt Request 0: No interrupt request from OUT endpoint 3. 1: Interrupt request from OUT endpoint 3.
[2] OUT2IRQ	OUT Endpoint 2 Interrupt Request 0: No interrupt request from OUT endpoint 2. 1: Interrupt request from OUT endpoint 2.
[1] OUT1IRQ	OUT Endpoint 1 Interrupt Request 0: No interrupt request from OUT endpoint 1. 1: Interrupt request from OUT endpoint 1.
[0] OUT0IRQ	OUT Endpoint 0 Interrupt Request 0: No interrupt request from OUT endpoint 0. 1: Interrupt request from OUT endpoint 0.

17.3.14. USB Protocol Interrupt Request Subregister

The USB Protocol Interrupt Request Subregister, shown in Table 183, indicates USB protocol interrupt requests. The interrupt is cleared by writing a 1 to the corresponding register position.

Table 183. USB Protocol Interrupt Request Subregister (USBIRQ)

Bit	7	6	5	4	3	2	1	0
Field	Reserved			URESIRQ	SUSPIRQ	SUTOKIRQ	SOFIRQ	SUDAVIRQ
Reset	0	0	0	0	0	0	0	0
R/W	R	R	R	R/W1*	R/W1*	R/W1*	R/W1*	R/W1*
Address	If USBSA = 2Bh in the USB Subaddress Register, accessible through the USB Subdata Register							

Note: *R/W1 = Writing a 1 clears this bit.

Bit	Description
[7:5]	Reserved These bits are reserved and must be programmed to 000.
[4] URESIRQ	USB Reset Bus State Interrupt Request 0: No USB Reset bus state detected. 1: USB Reset bus state detected. Write a 1 to this bit to clear the interrupt request.
[3] SUSPIRQ	USB Suspend Interrupt Request 0: No USB suspend detected. 1: USB suspend detected. Write a 1 to this bit to clear the interrupt request.
[2] SUTOKIRQ	USB Setup Token Interrupt Request 0: No USB Setup token received. 1: USB Setup token received. Write a 1 to this bit to clear the interrupt request.
[1] SOFIRQ	USB Start-of-Frame Interrupt Request 0: No USB Start-of-Frame (SOF) packet received. 1: USB Start-of-Frame (SOF) packet received. Write a 1 to this bit to clear the interrupt request.
[0] SUDAVIRQ	USB Setup Stage Data Valid Interrupt Request 0: No error-free setup stage data packet received. 1: Error-free setup stage data packet received. Write a 1 to this bit to clear the interrupt request.

17.3.15. USB IN Interrupt Enable Subregister

The USB IN Interrupt Enable Subregister, shown in Table 184, controls the enabling of IN endpoint interrupt requests.

Table 184. USB IN Interrupt Enable Subregister (USBINIEN)

Bit	7	6	5	4	3	2	1	0
Field	Reserved				IN3IEN	IN2IEN	IN1IEN	IN0IEN
Reset	0	0	0	0	0	0	0	0
R/W	R	R	R	R	R/W	R/W	R/W	R/W
Address	If USBSA = 2Ch in the USB Subaddress Register, accessible through the USB Subdata Register							

Bit	Description
[7:4]	Reserved These bits are reserved and must be programmed to 0000.
[3] IN3IEN	IN Endpoint 3 Interrupt Enable 0: Interrupts from IN endpoint 3 are disabled. 1: Interrupts from IN endpoint 3 are enabled.
[2] IN2IEN	IN Endpoint 2 Interrupt Enable 0: Interrupts from IN endpoint 2 are disabled. 1: Interrupts from IN endpoint 2 are enabled.
[1] IN1IEN	IN Endpoint 1 Interrupt Enable 0: Interrupts from IN endpoint 1 are disabled. 1: Interrupts from IN endpoint 1 are enabled.
[0] IN0IEN	IN Endpoint 0 Interrupt Enable 0: Interrupts from IN endpoint 0 are disabled. 1: Interrupts from IN endpoint 0 are enabled.

17.3.16. USB OUT Interrupt Enable Subregister

The USB OUT Interrupt Enable Subregister, shown in Table 185, controls the enabling of OUT endpoint interrupt requests.

Table 185. USB OUT Interrupt Enable Subregister (USBOUTIEN)

Bit	7	6	5	4	3	2	1	0
Field	Reserved				OUT3IEN	OUT2IEN	OUT1IEN	OUT0IEN
Reset	0	0	0	0	0	0	0	0
R/W	R	R	R	R	R/W	R/W	R/W	R/W
Address	If USBSA = 2Dh in the USB Subaddress Register, accessible through the USB Subdata Register							

Bit	Description
[7:4]	Reserved These bits are reserved and must be programmed to 0000.
[3]	OUT Endpoint 3 Interrupt Enable OUT3IEN 0: Interrupts from OUT endpoint 3 are disabled. 1: Interrupts from OUT endpoint 3 are enabled.
[2]	OUT Endpoint 2 Interrupt Enable OUT2IEN 0: Interrupts from OUT endpoint 2 are disabled. 1: Interrupts from OUT endpoint 2 are enabled.
[1]	OUT Endpoint 1 Interrupt Enable OUT1IEN 0: Interrupts from OUT endpoint 1 are disabled. 1: Interrupts from OUT endpoint 1 are enabled.
[0]	OUT Endpoint 0 Interrupt Enable OUT0IEN 0: Interrupts from OUT endpoint 0 are disabled. 1: Interrupts from OUT endpoint 0 are enabled.

17.3.17. USB Protocol Interrupt Enable Subregister

The USB Protocol Interrupt Enable Subregister, shown in Table 186, controls the enabling of USB protocol interrupt requests.

Table 186. USB Protocol Interrupt Enable Subregister (USBIEN)

Bit	7	6	5	4	3	2	1	0
Field	Reserved			URESIEN	SUSPIEN	SUTOKIEN	SOFIEN	SUDAVIEN
Reset	0	0	0	0	0	0	0	0
R/W	R	R	R	R/W	R/W	R/W	R/W	R/W
Address	If USBSA = 2Eh in the USB Subaddress Register, accessible through the USB Subdata Register							

Bit	Description
[7:5]	Reserved These bits are reserved and must be programmed to 000.
[4] URESIEN	USB Reset Bus State Interrupt Enable 0: No interrupt upon USB bus reset detect. 1: Interrupt upon USB bus reset detected.
[3] SUSPIEN	USB Suspend Interrupt Enable 0: No interrupt upon USB suspend detected. 1: Interrupt upon USB suspend detected.
[2] SUTOKIEN	USB Setup Token Interrupt Enable 0: No interrupt upon USB Setup token received. 1: Interrupt upon USB Setup token received.
[1] SOFIEN	USB Start-of-Frame Interrupt Enable 0: No interrupt upon USB Start-of-Frame (SOF) packet received. 1: Interrupt upon USB Start-of-Frame (SOF) packet received.
[0] SUDAVIEN	USB Setup Stage Data Valid Interrupt Enable 0: No interrupt upon error free Setup data packet received. 1: Interrupt upon error free Setup data packet received.

17.3.18. USB Endpoint 0 Control and Status Subregister

The USB Endpoint 0 Control and Status Subregister, shown in Table 187, provides control and status for USB endpoint 0.

Table 187. USB Endpoint 0 Control and Status Subregister (USBEP0CS)

Bit	7	6	5	4	3	2	1	0
Field	Reserved		CHGSET	DSTALL	OUTBUSY	INBUSY	HSNAK	STALL
Reset	0	0	0	0	1	0	0	0
R/W	R	R	R/W1*	R/W	R/W1*	R	R/W1*	R/W
Address	If USBSA = 34h in the USB Subaddress Register, accessible through the USB Subdata Register							

Note: *R/W1 = Writing a 1 clears this bit.

Bit	Description
[7:6]	Reserved These bits are reserved and must be programmed to 00.
[5] CHGSET	Setup Buffer Contents Changed CHGSET is automatically set when USB Module receives a setup data packet. Software clears CHGSET by writing a 1 to it. 0: No change to the setup buffer contents. 1: Setup buffer contents changed.
[4] DSTALL	EP0 Data Stall When DSTALL is set and USB Module sends STALL in the Data stage, the STALL bit is automatically set to 1 and USB Module will send STALL handshake also in the Status stage. Typically, DSTALL is set after the last successful transaction in the Data stage when all expected bytes of the transfer have been received or sent by the USB Module and a STALL handshake is to be sent for any additional Data stage tokens. If DSTALL is set, a token that indicates a transition to the status stage (ex. OUT token for an IN endpoint) will not cause a STALL handshake. DSTALL is automatically cleared when a Setup token arrives. 0: Do not send a STALL handshake for any IN or OUT token in the Data stage. 1: Send a STALL handshake for any IN (IN endpoint) or OUT (OUT endpoint) token in the Data stage.
[3] OUTBUSY	EP0 OUT Busy Status 0: Software has control of the OUT 0 endpoint buffer memory. 1: OUTBUSY is automatically cleared when a Setup token arrives. The USB Module has control of the OUT 0 endpoint buffer memory. OUTBUSY is set automatically when software writes a dummy value to BC in the USBEP0OUTBC Register. Software can clear OUTBUSY by writing a 1 to it.

Bit	Description (Continued)
[2] INBUSY	EP0 IN Busy Status The USB Module has control of the IN 0 endpoint buffer memory. INBUSY is set automatically when software writes BC in the USBEP0INBC Register. 0: Software has control of the IN 0 endpoint buffer memory. 1: INBUSY is automatically cleared when a Setup token arrives.
[1] HSNAK	EP0 Handshake NA HSNAK is automatically set when a Setup token arrives. Software clears HSNAK by writing a 1 to it. 0: Do not send a NAK handshake. 1: Send a NAK handshake for every packet in the Status stage.
[0] STALL	EP0 Stall STALL is automatically cleared when a Setup token arrives. 0: Do not send a STALL handshake. 1: Send a STALL handshake for any IN or OUT token during the data or handshake phases of the control transfer.

17.3.19. USB IN 0–3 Byte Count Subregisters

The USB IN 0–3 Byte Count subregisters, shown in Table 188, contain the USB IN endpoint byte counts.

Table 188. USB IN 0–3 Byte Count Subregisters (USB_IxBC)

Bit	7	6	5	4	3	2	1	0
Field	Reserved	BC						
Reset	0	0	0	0	0	0	0	0
R/W	R	R/W	R/W	R/W	R/W	R/W	R/W	R
Address	If USB _{SA} = 35h, 37h, 39h, 3Bh in the USB Subaddress Register, accessible through the USB Subdata Register							

Bit	Description
[7]	Reserved This bit is reserved and must be programmed to 0.
[6:0] BC	IN Byte Count 00–40: After loading the IN endpoint x buffer memory, software should write BC with the number of bytes loaded. Writing to the USB _I xBC Register arms the IN endpoint x by setting BUSY in USB _I xCS. When the host sends an IN token for IN endpoint x and BUSY is set, the USB Module will transmit a BC length data packet. 41–7F: Reserved.

17.3.20. USB IN 1–3 Control and Status Subregister

The USB IN 1–3 Control and Status subregisters, shown in Table 189, provide control and status for USB IN endpoints 1–3.

Table 189. USB Subaddress Subregister (USB_IxCS)

Bit	7	6	5	4	3	2	1	0
Field	Reserved						INBUSY	STALL
Reset	0	0	0	0	0	0	0	0
R/W	R	R	R	R	R	R	R	R/W
Address	If USB _{SA} = 36h, 38h, 3Ah in the USB Subaddress Register, accessible through the USB Subdata Register							

Bit	Description
[7:2]	Reserved These bits are reserved and must be programmed to 000000.
[1]	IN Busy Status
INBUSY	When the host sends an IN token for the IN endpoint and the INBUSY bit is set, the USB Module will transmit a BC length data packet, then clear the INBUSY bit. While INBUSY is set, software should not access the buffer memory for this IN endpoint. A 1 to 0 transition of INBUSY generates a USB interrupt request for the IN endpoint. 0: Software has control of the IN endpoint buffer memory. The IN endpoint buffer memory is empty and ready for loading by software. 1: The USB Module has control of the IN endpoint buffer memory. INBUSY is set automatically when software writes BC in the USB _I xBC Subregister.
[0]	IN Stall
STALL	0: Do not send a STALL handshake. 1: Send a STALL handshake for all requests to the endpoint.

17.3.21. USB OUT 0–3 Byte Count Subregisters

The USB OUT 0–3 Byte Count subregisters, shown in Table 190, contain the USB OUT endpoint byte counts.

Table 190. USB OUT 0–3 Byte Count Subregisters (USBOxBC)

Bit	7	6	5	4	3	2	1	0
Field	Reserved	BC						
Reset	0	0	0	0	0	0	0	0
R/W	R	R	R	R	R	R	R	R
Address	If USBSA = 45h, 47h, 49h, 4Bh in the USB Subaddress Register, accessible through the USB Subdata Register							

Bit	Description
[7]	Reserved This bit is reserved and must be programmed to 0.
[6:0] BC	OUT Byte Count 00–40: BC contains the number of bytes sent during the last OUT transfer from the host to the OUT endpoint x. 41-7F: Reserved.

17.3.22. USB OUT 1–3 Control and Status Subregisters

The USB OUT 1–3 Control and Status subregisters, shown in Table 191, provide control and status for USB OUT endpoints 1–3.

Table 191. USB OUT 1–3 Control and Status Subregisters (USBOxCS)

Bit	7	6	5	4	3	2	1	0
Field	Reserved						OUTBUSY	STALL
Reset	0	0	0	0	0	0	0	0
R/W	R	R	R	R	R	R	R	R/W
Address	If USBSA = 46h, 48h, 4Ah in the USB Subaddress Register, accessible through the USB Subdata Register							

Bit	Description
[7:2]	Reserved These bits are reserved and must be programmed to 000000.
[1] OUTBUSY	OUT Busy Status Software sets OUTBUSY by reloading the USBOxBC Register with a dummy value. While OUTBUSY is set, software should not read the buffer memory for this OUT endpoint. A 1 to 0 transition of OUTBUSY generates a USB interrupt request for the OUT endpoint. 0: Software has control of the OUT endpoint buffer memory. The OUT endpoint buffer memory is ready for reading by software. 1: The USB Module has control of the OUT endpoint buffer memory which is empty and ready to receive the next data packet from the host.
[0] STALL	Out Stall 0: Do not send a STALL handshake. 1: Send a STALL handshake for all requests to the endpoint.

17.3.23. USB Control and Status Subregister

The USB Control and Status Subregister, shown in Table 192, provides USB control and status.

Table 192. USB Control and Status Subregister (USBCS)

Bit	7	6	5	4	3	2	1	0
Field	DEVRSUME	Reserved	SOFWDOG	Reserved	DISCON	Reserved	FORCEJ	SIGRSUME
Reset	0	0	0	0	1	0	0	0
R/W	R/W1*	R	R/W	R	R/W	R	R/W	R/W
Address	If USBSA = 56h in the USB Subaddress Register, accessible through the USB Subdata Register							
Note: *R/W1 = Writing a 1 clears this bit.								

Bit	Description
[7] DEVRSUME	Wake-Up Source Software resets this bit by writing a 1 to it. See the Device-Initiated Resume (Remote Wake-Up) section on page 353 for details. 0: No device-initiated resume. 1: The USB Module resumed due to device-initiated resume.
[6]	Reserved This bit is reserved and must be programmed to 0.
[5] SOFWDOG	Start of Frame (SOF) Watchdog The internal SOF timer is used to generate SOF interrupts for cases in which the SOF issued by the USB host is missed. 0: Internal SOF timer is disabled. 1: Internal SOF timer is enabled.
[4]	Reserved This bit is reserved and must be programmed to 0.
[3] DISCON	Disconnect the Internal Pull-Up Resistor 0: The internal pull-up resistor is connected. 1: The internal pull-up resistor is disconnected.
[2]	Reserved This bit is reserved and must be programmed to 0.

Bit	Description (Continued)
[1] FORCEJ	<p>Force the Data J Bus State</p> <p>Forcing the Data J bus state between the Idle state and the Data K bus state can be performed to raise the crossover voltage to avoid a false Single-Ended-Zero (SE0). 0: No Force Data J Bus State Signaling. 1: FORCEJ should be set only in the Suspend state. Software can set FORCEJ to drive the Data J bus state on the USB bus and then clear FORCEJ and set SIGRSUME to drive the data state for resume on the USB bus.</p>
[0] SIGRSUME	<p>Signal Remote Device Resume</p> <p>0: No remote device resume signaling. 1: Signal remote device resume by driving the Data K bus state on the USB bus.</p>

17.3.24. USB Toggle Control Subregister

The USB Toggle Control Subregister, shown in Table 193, provides access to the endpoint toggle bits.

Table 193. USB Toggle Control Subregister (USBTOGCTL)

Bit	7	6	5	4	3	2	1	0
Field	DATA	TDATA1	TDATA0	IN/OUT	Reserved		EP	
Reset	0	0	0	0	0	0	0	0
R/W	R	R0/W*	R0/W*	R/W	R	R/W	R/W	R/W
Address	If USBSA = 57h in the USB Subaddress Register, accessible through the USB Subdata Register							
Note: *R0/W = Write but reads back as 0.								

Bit	Description
[7] DATA	<p>Data Toggle Value</p> <p>Before reading DATA, software should configure IN/OUT and EP to the desired endpoint. 0: The data toggle is set to DATA0 for the endpoint selected by IN/OUT and EP. 1: The data toggle is set to DATA1 for the endpoint selected by IN/OUT and EP.</p>
[6] TDATA1	<p>Set Data Toggle to Data1</p> <p>IN/OUT and EP need to be configured before setting TDATA1. See the Toggle Control section on page 351 for details. 0: Data toggle value unchanged. 1: Set the data toggle value to DATA1 for the endpoint selected by IN/OUT and EP.</p>
[5] TDATA0	<p>Clear Data Toggle to Data0</p> <p>IN/OUT and EP need to be configured before setting TDATA0. See the Toggle Control section on page 351 for details. 0: Data toggle value unchanged. 1: Set the data toggle value to DATA0 for the endpoint selected by IN/OUT and EP.</p>

Bit	Description (Continued)
[4] IN/OUT	IN/OUT Endpoint Select 0: OUT endpoint is selected. 1: IN endpoint is selected.
[3:2]	Reserved These bits are reserved and must be programmed to 00.
[1:0] EP	Endpoint Select 00: Endpoint 0. 01: Endpoint 1. 10: Endpoint 2. 11: Endpoint 3.

17.3.25. USB Frame Count Subregisters

The USB Frame Count Low and USB Frame Count High subregisters, shown in Tables 194 and 195, contain the USB frame count and are updated at each Start of Frame (SOF).

Table 194. USB Frame Count Low Subregister (USBFCL)

Bit	7	6	5	4	3	2	1	0
Field	FCL							
Reset	0	0	0	0	0	0	0	0
R/W	R	R	R	R	R	R	R	R
Address	If USBSA = 58h in the USB Subaddress Register, accessible through the USB Subdata Register							

Bit	Description
[7:0] FCL	Frame Count Low 00–FF: Lower 8-bits of the USB Frame Count.



Table 195. USB Frame Count High Subregister (USBFCH)

Bit	7	6	5	4	3	2	1	0
Field	Reserved					FCH		
Reset	0	0	0	0	0	0	0	0
R/W	R	R	R	R	R	R	R	R
Address	If USBSA = 59h in the USB Subaddress Register, accessible through the USB Subdata Register							

Bit	Description
[7:3]	Reserved These bits are reserved and must be programmed to 00000.
[2:0] FCH	Frame Count High 0–7: Upper 3-bits of the USB Frame Count.

17.3.26. USB Function Address Subregister

The USB Function Address Subregister, shown in Table 196, contains the USB function address.

Table 196. USB Function Address Subregister (USBFNADDR)

Bit	7	6	5	4	3	2	1	0
Field	Reserved	FNADDR						
Reset	0	0	0	0	0	0	0	0
R/W	R	R	R	R	R	R	R	R
Address	If USBSA = 5Bh in the USB Subaddress Register, accessible through the USB Subdata Register							

Bit	Description
[7]	Reserved This bit is reserved and must be programmed to 0.
[6:0] FNADDR	Function Address 00–7F: Function address sent by the host. The USB Module responds only when the packet function address matches the function address assigned to the USB Module.

17.3.27. USB Endpoint Pairing Subregister

The USB Endpoint Paring Subregister, shown in Table 197, controls pairing of USB endpoints.

Table 197. USB Endpoint Pairing Subregister (USBPAIR)

Bit	7	6	5	4	3	2	1	0
Field	Reserved				PROUT23	Reserved		PRIN23
Reset	0	0	0	0	0	0	0	0
R/W	R	R	R	R	R/W	R	R	R/W
Address	If USBSA = 5Dh in the USB Subaddress Register, accessible through the USB Subdata Register							

Bit	Description
[7:4]	Reserved These bits are reserved and must be programmed to 0000.
[3] PROUT23	OUT 2 and OUT 3 Pairing 0: OUT 2 and OUT 3 are not paired. 1: OUT 2 and OUT 3 are paired.
[2:1]	Reserved These bits are reserved and must be programmed to 00.
[0] PRIN23	IN 2 and IN 3 Pairing 0: IN 2 and IN 3 are not paired. 1: IN 2 and IN 3 are paired.

17.3.28. USB IN Endpoint Valid Subregister

The USB IN Endpoint Valid Subregister, shown in Table 198, selects which IN endpoints are valid.

Table 198. USB IN Endpoint Valid Subregister (USBINVAL)

Bit	7	6	5	4	3	2	1	0
Field	Reserved				IN3VAL	IN2VAL	IN1VAL	INOVAL
Reset	0	0	0	0	0	0	0	1
R/W	R	R	R	R	R/W	R/W	R/W	R/W
Address	If USBSA = 5Eh in the USB Subaddress Register, accessible through the USB Subdata Register							

Bit	Description
[7:4]	Reserved These bits are reserved and must be programmed to 0000.
[3] IN3VAL	IN 3 Endpoint Valid 0: IN 3 is not valid. 1: IN 3 is valid.
[2] IN2VAL	IN 2 Endpoint Valid 0: IN 2 is not valid. 1: IN 2 is valid.
[1] IN1VAL	IN 1 Endpoint Valid 0: IN 1 is not valid. 1: IN 1 is valid.
[0] INOVAL	IN 0 Endpoint Valid 0: IN 0 is not valid. 1: IN 0 is valid.

17.3.29. USB OUT Endpoint Valid Subregister

The USB OUT Endpoint Valid Subregister, shown in Table 199, selects which OUT endpoints are valid.

Table 199. USB OUT Endpoint Valid Subregister (USBOUTVAL)

Bit	7	6	5	4	3	2	1	0
Field	Reserved				OUT3VAL	OUT2VAL	OUT1VAL	OUT0VAL
Reset	0	0	0	0	0	0	0	1
R/W	R	R	R	R	R/W	R/W	R/W	R
Address	If USBSA = 5Fh in the USB Subaddress Register, accessible through the USB Subdata Register							

Bit	Description
[7:4]	Reserved These bits are reserved and must be programmed to 0000.
[3] OUT3VAL	OUT 3 Endpoint Valid 0: OUT 3 is not valid. 1: OUT 3 is valid.
[2] OUT2VAL	OUT 2 Endpoint Valid 0: OUT 2 is not valid. 1: OUT 2 is valid.
[1] OUT1VAL	OUT 1 Endpoint Valid 0: OUT 1 is not valid. 1: OUT 1 is valid.
[0] OUT0VAL	OUT 0 Endpoint Valid 0: Reserved. 1: OUT 0 is valid.

17.3.30. USB IN Endpoints Stop Address Subregister

The USB IN Endpoints Stop Address Subregister, shown in Table 200, defines the stop address for the uppermost IN endpoint.

Table 200. USB IN Endpoints Stop Address Subregister (USBISPADDR)

Bit	7	6	5	4	3	2	1	0
Field	Reserved		INSPADDR					
Reset	0	0	1	0	0	0	0	0
R/W	R	R	R0/W*	R0/W*	R0/W*	R0/W*	R0/W*	R0/W*
Address	If USBSA = 62h in the USB Subaddress Register, accessible through the USB Subdata Register							
Note: *R0/W = Write but reads back as 0								

Bit	Description
[7:6]	Reserved These bits are reserved and must be programmed to 00.
[5:0] INSPADDR	IN Stop Address 00–3F: The stop address for the uppermost IN endpoint. {INSPADDR[5:0], 0, 0, 0, 0} maps to buffer memory address [9:0], therefore the minimum increment of INSPADDR is 16 bytes of buffer memory. Additionally, 2*(8*INSPADDR minus the uppermost INADDR) determines the size in bytes of the uppermost IN endpoint buffer memory. See the USB Endpoint Buffer Memory section on page 341 for details.

17.3.31. USB Setup Buffer Byte 0–7 Subregisters

The USB Setup Byte 0–7 subregisters, shown in Table 201, contain the 8 bytes of the Setup stage data packet from the latest control transfer.

Table 201. USB Setup Buffer Byte 0–7 Subregisters (USBSUx)

Bit	7	6	5	4	3	2	1	0
Field	SETUP							
Reset	0	0	0	0	0	0	0	0
R/W	R	R	R	R	R	R	R	R
Address	If USBSA = 68h-6Fh in the USB Subaddress Register, accessible through the USB Subdata Register							

Bit	Description
[7:0]	USB Setup Byte
SETUP	00–FF: Setup data byte from the latest control transfer.

Chapter 18. Direct Memory Access Controller

The Z8 Encore! Direct Memory Access (DMA) Controller provides four independent Direct Memory Access channels that provide high-speed transfers, offloading the CPU. The features of the DMA Controller include:

- Four independent DMA channels
- Flexible address control: fixed, increment, decrement, fixed word
- Register File \Leftrightarrow Register File, Register File \Leftrightarrow peripheral, peripheral \Leftrightarrow Register File, peripheral \Leftrightarrow peripheral transfers
- Direct or linked list operation
- Chaining of channel pairs to form a multi-transfer operation
- Round robin and fixed request priorities
- DMA and CPU bandwidth sharing control
- Up to 4KB transfers
- End-of-count and watermark interrupts
- Two System Clock cycles per DMA transfer

18.1. Architecture

The DMA Controller is comprised of four independent channels. Each channel has its own source, destination, transfer count and control registers. Each channel can be programmed to select one of the available DMA request sources.

The DMA architecture, shown in Figure 60, consists of DMA request multiplexers, DMA channels, and the arbiter and bus controller.

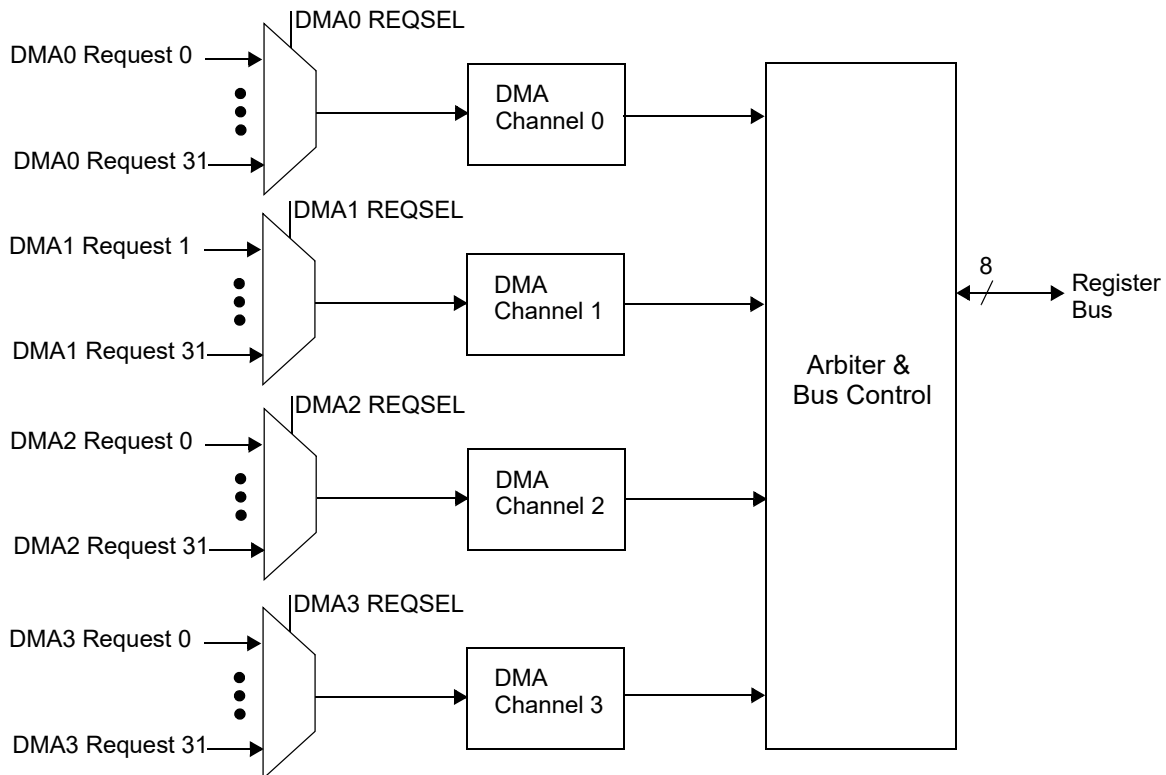

Figure 60. Direct Memory Access Block Diagram

18.2. Operation

The DMA Controller directly transfers data by sharing the Register Bus with the eZ8 CPU. Register Bus bandwidth allocation between the CPU and DMA is configurable.

the DMA Controller transfers data to or from buffers. A buffer is an allocation of contiguous memory bytes. Buffers are allocated by software to be used by the DMA Controller. A typical application would be to send data to serial channels such as I²C, UART, and SPI. The data to be sent is placed in a buffer by software.

the DMA Controller can be configured directly using the DMA registers, or DMA descriptors can be located in the Register File and accessed by the DMA Controller as a linked list.

Linked list operation is available on all four channels. Each channel has its own linked list state logic. When a descriptor or set of descriptors are created and the linked list operation is enabled, the DMA Controller will load the descriptor(s) into registers and perform the required DMA operation.

18.2.1. DMA Registers and Subregisters

Nine registers provide access to DMA control: two registers for each of the four DMA channels, plus a single global DMA control register. Use a DMA 0–3 Subaddress/Status Register (DMAxSA) and a DMA 0–3 Subdata Register (DMAxSd) together to provide access to subregisters for DMA channel configuration and control. DMAxSD provides a portal to the ten subregisters of each DMA channel. See the [DMA Control Register Definitions](#) section on page 399 to learn more.

18.2.2. Address Control

The DMA source address subregisters (DMAxSRCH and DMAxSRCL), containing the source address {SRCH, SRCL}, point to the data to be transferred. Each time a transfer occurs, the source address will either increment, decrement, stay fixed, or toggle the LSB (fixed word), as selected by the SRCCTL bit in the DMAxCTL0 subregisters.

The destination address subregisters (DMAxDSTH and DMAxDSTL), containing the destination address {DSTH, DSTL}, point to the destination for the data transfer. Each time a transfer occurs, the destination address will either increment, decrement, stay fixed, or toggle the LSB (fixed word), as selected by the DSTCTL bit in the DMAxCTL0 subregisters.

Fixed address control is useful when accessing 8-bit peripherals. Increment or decrement address control is useful when transferring a block of data, depending on the order of data in the buffer (ascending or descending).

Fixed word address control provides convenient access to 2-byte data words from 16-bit peripherals such as in the timers or the ADC. After each transfer, the least significant bit of the fixed word address is toggled, and the byte count is decremented. If the initial address ends with 0, the next address will end with 1, effectively counting up. If the initial address ends with 1, the next address will end with 0, effectively counting down.

18.2.3. DMA Request Selection

The DMA requestor is selected with the REQSELbit in the DMAxCTL1 registers. If REQSEL=0, software initiates a DMA transfer upon enabling the DMA Controller. This selection is useful for transferring data between sections of the Register File. If REQSEL=1–31, the corresponding peripheral identified in the DMAxCTL1 registers initiates the DMA transfer.

To learn more about when a particular DMA requestor asserts and deasserts a DMA request, refer to the following sections of this product specification:

[10.1.5. Timer Interrupts and DMA](#) – see page 170

[11.4. Multi-Channel Timer Interrupts and DMA](#) – see page 192

[14.1.14. UART-LDD and DMA Support](#) – see page 254

[15.3.7. ESPI and DMA](#) – see page 294

[16.2.7. DMA Control of I2C Transactions](#) – see page 326

[17.2.10. USB Module Interrupts and DMA](#) – see page 355

[20.2.1. AES Operation and DMA](#) – see page 427

[21.2.8. ADC Interrupts and DMA](#) – see page 451

[22.2.4. DAC Interrupt and DMA](#) – see page 470

18.2.4. Transfer Types

Three transfer types provide Register Bus bandwidth-sharing options, and are selected with the BURST bit in the DMA Control Register. If no DMA requests are asserted, the CPU has 100% of the Register Bus bandwidth.

18.2.4.1. Block (BURST=00)

The DMA Controller can be configured to transfer data blocks by selecting BURST=00. It will transfer the entire transfer length as long as the DMA request is asserted.

The CPU will not execute instructions while the DMA Controller is transferring the block. The DMA Controller will pause to allow CPU execution, but only if the DMA requestor does not continue to assert DMA requests during the block transfer. Care should be taken using block transfer if CPU response time is critical.

18.2.4.2. Burst4 (BURST=01)

The DMA Controller can be configured to limit data transfer length to bursts of 4 transfers by selecting BURST=01. After 4 consecutive DMA transfers, the CPU is allowed to execute an instruction; i.e., one CPU instruction is interleaved with a burst of 4 DMA transfers.

If the requesting DMA does not require all four transfers and deasserts a DMA request, CPU instruction execution will occur after the last required transfer.

18.2.4.3. Single (BURST=10)

The DMA Controller can be configured to limit data transfer length to a single transfer by selecting BURST=10. After a DMA transfer, the CPU will execute one instruction; i.e., one CPU instruction is interleaved with each DMA transfer).

18.2.5. Direct Operation

18.2.5.1. DMA Setup with Autoincrement

The DMA Subregister selection and status registers have an autoincrement that allows the DMA Controller to be set up without modifying the DMASA subregister address in the DMAxSA Register. To enable autoincrementing, set the AUTOINC bit in the DMA Control Register. DMASA is autoincremented whenever DMAxSD is accessed (i.e., read or written) while DMAx is not active. This autoincrement allows for convenient channel setup, because software can sequentially write to the DMA channel subregisters without

causing intervening writes to DMAxSA. To take advantage of autoincrementing, software must write the DMAxSD values in order, typically from subregister address 0 (DMAxSRCH) to subregister address 7 (DMAxCTL1). When the autoincremented value of DMASA reaches 7, the next access to DMAxSD will reset DMASA back to 0.

Autoincrementing is not required to start from zero; it will always start from the address value in DMASA. To write only the transfer count value and then reenble the DMA, configure DMASA to 4h, then write the DMAxSD Register four times to access the DMA count and control subregisters in the same order listed above.

If DMASA is written with a value greater than 7, the autoincrement function will toggle DMASA[0] at each DMAxSD access for convenient cycling between subregister addresses 8 and 9 when configuring linked list operation. To return to the lower subregisters, write DMASA with a value less than 8h.

Clear the AUTOINC bit before executing an instruction to manipulate bits in a DMA subregister such as AND, BIT, and OR. These instructions perform read-modify-write operations. If AUTOINC is set, these instructions will cause the subregister address to increment twice: first upon the read, and again upon the write.

DMA active status can be polled by reading the ACT bit in the DMAxSA Register, or by reading the ENABLE bit in the DMAxCTL1 Subregister.

18.2.5.2. Chain Operation

DMA channel pairs may be chained together to form a multi-transfer operation. If the CHAIN01 bit is set in the DMACTL Register, DMA0 is chained to DMA1. The same operation is true if the CHAIN23 bit is set in the DMACTL Register and DMA2 is chained to DMA3.

When chain operation is enabled for a DMA channel pair, initially one DMA channel of the pair should be enabled. When the enabled DMA channel reaches an end-of-count, it will reset its ENABLE bit, set its partner's ENABLE bit, then clear the CHAINxy bit. Software should service the corresponding buffer and, if further chaining is desired, again set CHAINxy. This setting enables the chained channel to perform DMA operation such that the DMA channels work in a ping-pong fashion.

18.2.6. Linked List Operation

To implement seamless back-to-back DMA transactions, linked list operation is available. Linked list operation can be selected on a channel-by-channel basis.

18.2.6.1. Operation

Linked list operation employs descriptors in the Register File to control DMA. These descriptors are usually set up as lists of descriptors. Each descriptor consists of 8 bytes and must be aligned on an 8-byte address boundary. The 8 bytes of the descriptor correspond directly to the first 8 subregisters of the DMA channel. In this description of linked list

operation, the descriptor bytes will be identified as a descriptor byte with a corresponding subregister name; e.g., a DMAxCTL0 descriptor byte.

After creating one or multiple descriptors in the Register File, software writes the address of the first linked list descriptor to {LAH, LAL} in the Linked List Descriptor Address subregisters (DMAxLAH and DMAxLAL), thereby providing the DMA Controller with the descriptor location in the Register File. The write to DMAxLAL also triggers the DMA Controller to automatically start linked list operation. The DMA Controller then reads into the DMA subregisters the descriptor pointed to by {LAH, LAL}, and assuming the ENABLE bit is set in the DMAxCTL1 descriptor byte, the DMA Controller executes the descriptor. Linked list operation active status can be polled by reading LLACT in the DMAxSA Register.

When the DMA Controller reaches an end-of-count, it can write completion status back to the descriptor by clearing the ENABLE bit in the DMAxCTL1 descriptor byte, and it can generate an interrupt, if enabled, signalling that execution of the descriptor has been completed. The DMA Controller then increments the linked list descriptor address, {LAH, LAL}, by 8 to point to the next descriptor; it then transfers the new descriptor to the DMA Subregister.

Linked list operation will be disabled upon reaching the end-of-count if the HALT bit is set in the DMAxCTL0 descriptor byte of the current descriptor. Upon reading a descriptor with the ENABLE bit cleared, the DMA Controller will become disabled. In addition, software can stop a linked list DMA operation by directly clearing the ENABLE bit in the DMAxCTL1 Subregister for that channel. In this case, the DMA Controller will complete any transaction in progress, then stop.

► **Note:** During linked list operation, the ENABLE bit is set while executing descriptors and cleared while reading descriptors. The DMA Controller will be disabled only if the ENABLE bit is cleared while executing a descriptor. Software can clear the ENABLE bit twice in succession to guarantee that the ENABLE bit is cleared while executing a descriptor. Alternatively, global disable, the GDISABLE bit in the DMACTL Register, can be set to pause DMA activity, then the ENABLE bit can be read. If the ENABLE bit is set, software can clear the ENABLE bit to disable the DMA Controller and clear GDISABLE.

Any time a DMA is disabled while in linked list operation, the DMA Controller reverts back to direct operation. A write to the DMAxLAL Subregister is required to again start linked list operation.

18.2.6.2. Descriptor Setup

A DMA descriptor consists of eight bytes located in the Register File, and contains the same information that is written to configure direct operation. These descriptor bytes are loaded by the DMA Controller to the first 8 DMA subregisters, DMAxSRCH through

DMAxCTL. Descriptors are generally set up as a list of descriptors, as shown in Table 202.

Table 202. DMA Descriptors

Address	Value	Descriptor #
Start Address	DMAx Source Address High	; Descriptor 0
Start Address + 1	DMAx Source Address Low	
Start Address + 2	DMAx Destination Address High	
Start Address + 3	DMAx Destination Address Low	
Start Address + 4	DMAx Count High	
Start Address + 5	DMAx Count Low	
Start Address + 6	DMAx Control 0	
Start Address + 7	DMAx Control 1	
Start Address + 8	DMAx Source Address High	; Descriptor 1
Start Address + 9	DMAx Source Address Low	
Start Address + 10	DMAx Destination Address High	
Start Address + 11	DMAx Destination Address Low	
Start Address + 12	DMAx Count High	
Start Address + 13	DMAx Count Low	
Start Address + 14	DMAx Control 0	
Start Address + 15	DMAx Control 1	

18.2.6.3. Linked List Control Options

There are a number of control options for linked list operation that affect descriptor usage; these options are selected with the TXLIST bit in DMAxSRCH descriptor byte, and the LLCTL bit in the DMAxCTL0 descriptor byte. The following passages explain the control options.

Transfer In List. The *transfer in list* option is used to load a new linked list descriptor address into the DMAxLAH and DMAxLAL subregisters. If the transfer in list option is selected by setting the TXLIST bit, only the first two descriptor bytes – the source address positions – are read from the descriptor, and the values are transferred to the Linked List Descriptor Address subregisters, DMAxLAH and DMAxLAR.

After this address transfer, the DMA Controller will fetch and execute the descriptor from the new linked list address. The transfer in list option can be used to change to a different list or create a looping operation over a set of descriptors.

Status Write. When LLCTL=00, upon reaching an end-of-count, the DMA Controller will write the DMAxCTL1 Subregister contents back to the current descriptor in the Reg-

ister File. Because the ENABLE bit in the DMAxCTL1 Subregister is cleared upon reaching the end-of-count, the ENABLE bit in the descriptor will also be cleared. The CPU can poll the linked list descriptor {LAH, LAL} + 7 address to determine if the ENABLE bit is cleared, indicating that the transaction has completed.

When LLCTL=10, status writes are disabled such that the DMA Controller will not overwrite the linked list descriptor LAH, LAL} + 7 address. Because a status is not written back, the list can be used again.

Repeat Descriptor. When LLCTL=01, repeat descriptor operation is selected, and the DMA Controller loops on the current descriptor until disabled by software. When repeat descriptor operation is selected, the DMA Controller does not write a status back to the descriptor, nor does it increment the linked list descriptor address, {LAH, LAL}.

Software can terminate repeat descriptor operation in a number of ways:

- Directly clearing the ENABLE bit in the DMAxCTL1 Subregister will disable the DMA Controller when the current transaction, if any, completes
- Directly setting the HALT bit or changing the LLCTL bit in the DMAxCTL0 Subregister will result in the newly-specified operation commencing at the end-of-count
- Altering the ENABLE, HALT, or LLCTL bits in the descriptor bytes in the Register File. The descriptor changes will take effect when an end-of-count is reached prompting the DMA Controller to again read the descriptor

Halt. When the HALT bit is set, the DMA Controller will clear the ENABLE bit upon an end-of-count, thereby disabling the DMA Controller. When an end-of-count is reached with the HALT bit set, the DMA Controller will write a status if LLCTL=00. The linked list descriptor address, {LAH, LAL}, will not increment, but will point to the descriptor upon completion.

18.2.7. Global Disable

It is possible to quickly block DMA activity when the CPU requires 100% of the Register Bus bandwidth; for example, during high-priority interrupt service routines. When the GDISABLE bit in the DMACTL Register is set, DMA activity is blocked regardless of the state of the individual channel the ENABLE bit. Setting the GDISABLE bit does not affect the state of a DMA channel, and DMA activity resumes when the GDISABLE bit is cleared.

18.2.8. DMA Channel Priority

Two priority schemes can be selected for servicing DMA requests, namely: fixed priority and round-robin priority. Linked list descriptor fetch has the highest priority. The priority scheme is selected by the PRIORITY bit in the DMACTL Register.

18.2.8.1. Linked List Descriptor Request Priority

Because a linked list descriptor fetch has the highest priority, other DMA requests are ignored while a descriptor is being transferred from the Register File to the DMA registers.

18.2.8.2. Round Robin Priority

Round-robin priority is the default at System Reset, and is selected by clearing the PRIORITY bit. With round-robin priority, each channel request is serviced for the length of its burst size or until it deasserts a DMA request, whichever occurs first. After a channel is serviced, it is assigned lowest priority and is taken out of the rotation until all other requesting channels are serviced.

18.2.8.3. Fixed Priority

Fixed priority is selected by setting the PRIORITY bit. With fixed priority, channel requests are serviced with the following priority order from highest to lowest: DMA0, DMA1, DMA2, DMA3. Lower-priority DMA channels are not serviced until higher-priority DMA channels deassert DMA request.

18.2.9. Interrupts

Independent interrupt control is provided for end-of-count and watermark interrupts. An indication of whether the most recent interrupt was due to an end-of-count or watermark is provided by the IRQS bit in the DMA 0–3 Subregister Selection and Status registers.

18.2.10. End-of-Count Interrupt

An interrupt is generated when the end-of-count is reached. If interrupted on an end-of-count, the EOCIRQE bit is set in the DMAxCTL0 Subregister. The EOCIRQE bit can be cleared if the application is not required to service the buffer, or will service the buffer in conjunction with a future buffer.

18.2.11. Watermark Interrupt

The DMA Controller is able to generate an interrupt prior to an end-of-count being reached. If the value of the WMCNT bit in the DMAxCNTH Subregister matches the current count, {CNTH, CNTL}, in the DMAxCNTH and DMAxCNTL subregisters, a watermark interrupt will be generated. To disable watermark interrupts, configure WMCNT=0h.

Only a single watermark interrupt will be generated for a given count value.

18.3. DMA Control Register Definitions

Nine registers provide access to DMA control, two registers per each of the four DMA channels, plus a single global DMA control register. Table 203 lists these DMA registers. Use a DMA 0–3 Subaddress/Status Register (DMAxSA) and a DMA 0–3 Subdata Register (DMAxSD) together to provide access to subregisters for DMA channel configuration and control. DMAxSD provides a portal to the ten subregisters of each DMA channel.

Table 203. DMA Registers and Subregisters

DMA Register Mnemonic	Address	DMA Register Name
DMA0SA	FA8h	DMA 0 Subaddress/Status Register
DMA0SD	FA9h	DMA 0 Subdata Register
DMA1SA	FAAh	DMA 1 Subaddress/Status Register
DMA1SD	FABh	DMA 1 Subdata Register
DMA2SA	FACh	DMA 2 Subaddress/Status Register
DMA2SD	FADh	DMA 2 Subdata Register
DMA3SA	FAEh	DMA 3 Subaddress/Status Register
DMA3SD	FAFh	DMA 3 Subdata Register
DMACTL	FB0h	DMA Global Control Register
DMA Subregister Mnemonic	Subregister Address*	DMA Subregister Name
DMAxSRCH	0h	DMA Source Address High
DMAxSRCL	1h	DMA Source Address Low
DMAxDSTH	2h	DMA Destination Address High
DMAxDSTL	3h	DMA Destination Address Low
DMAxCNTH	4h	DMA Count High
DMAxCNTL	5h	DMA Count Low
DMAxCTL0	6h	DMA Control 0
DMAxCTL1	7h	DMA Control 1
DMAxLAH	8h	DMA Linked List Descriptor Address High
DMAxLAL	9h	DMA Linked List Descriptor Address Low

Note: *DMAxSA in each DMAxSA Register contains the subregister address.

18.3.1. DMA 0–3 Subaddress/Status Registers

The DMA 0–3 Subaddress/Status registers, shown in Table 204, provide status and select the DMA functionality accessible through the DMA 0–3 subregisters. The DMA 0–3 Subaddress/Status and DMA 0–3 Subdata registers combine to provide access to all DMA controls.

The DMASA bit in the DMAxSA Register is autoincremented whenever DMAxSD is accessed (read or written) while DMAx is not active. This autoincrementing allows for convenient channel setup, because software can sequentially write DMA channel subregisters without causing intervening writes to DMAxSA. To take advantage of autoincrementing, software must write the DMAxSD values in order, typically from subregister address 0 (DMAxSRCH) to subregister address 7 (DMAxCTL1). When the autoincremented value of DMASA reaches 7, the next access to DMAxSD will reset DMASA back to 0.

If the DMASA bit is written with a value greater than 7, the autoincrement function will toggle DMASA[0] upon each DMAxSD access for convenient cycling between subregister addresses 8 and 9.

Table 204. DMA 0–3 Subaddress/Status Register (DMAxSA)

Bit	7	6	5	4	3	2	1	0
Field	IRQS	Reserved	LLACT	ACT	DMASA			
Reset	0	0	0	0	0	0	0	0
R/W	R	R	R	R	R/W	R/W	R/W	R/W
Address	DMA0SA @ FA8h, DMA1SA @ FAAh, DMA2SA @ FACH, DMA3SA @ FAEh							
Note: x references bits in the range [3:0].								

Bit	Description
[7] IRQS	Interrupt Request Status 0: End-of-count interrupt was the most recent DMA interrupt. 1: Watermark interrupt was the most recent DMA interrupt.
[6]	Reserved This bit is reserved and must be programmed to 0.
[5] LLACT	Linked List Active LLACT is set by hardware when the DMAxLAL Register is written, and is cleared when the DMA Controller has stopped servicing the linked list. 0: No Linked List operation is in progress. 1: A Linked List operation is in progress.

Bit	Description (Continued)
[4] ACT	DMA Active The value of ACT reflects the value of ENABLE in the DMAxCTL1 Register. In linked list operation, LLACT should be checked instead. In linked list operation, ACT still reflects the state of the DMA enable bit, but will change state as the DMA Controller moves through the linked list operation; it is set while executing descriptors, and cleared while reading descriptors. 0: DMA is not active. 1: DMA is active.
[3:0] DMASA	DMA Subregister Address DMASA increments modulo 8 whenever DMAxSD is read or written while DMAx is inactive. If the DMASA is written with a value greater than 7 the autoincrement function will toggle DMASA[0] at each DMAxSD access for convenient cycling between subregister addresses 8 and 9. 0–9: Selects the DMAx channel subregister accessed by the DMAxSD access. A–F: Reserved.

18.3.2. DMA 0–3 Subdata Registers

The DMA 0–3 Subdata registers, shown in Table 205, set the DMA channel operation. The value in DMASA of the corresponding DMAx Subaddress/Status Register determines which DMAx subregister is read from or written to by a DMAx Subdata Register access. Whenever this register is accessed while DMAx is inactive, DMASA is incremented as described in the [DMA 0–3 Subaddress/Status Registers](#) section on page 400.

Table 205. DMA 0–3 Subdata Register (DMAxSD)

Bit	7	6	5	4	3	2	1	0
Field	DMASD							
Reset	0	0	0	0	0	0	0	0
R/W	R/W	R/W	R/W	R/W	R/W	R/W	R/W	R/W
Address	DMA0SD @ FA9h, DMA1SD @ FABh, DMA2SD @ FADh, DMA3SD @ FAFh							
Note: x references bits in the range [3:0].								

Bit	Description
[7:0] DMASD	00–FF: DMASD is a portal providing access to all subregisters that configure the DMA channel operation as selected by DMASA.

18.3.3. DMA Global Control Register

The DMA Global Control Register, shown in Table 206, controls the global DMA operations, including global disable, DMA priority control, burst transfer control and chain control for DMA channel pairs.

Table 206. DMA Global Control Register (DMACTL)

Bit	7	6	5	4	3	2	1	0
Field	GDISABLE	PRIORITY	BURST		Reserved	AUTOINC	CHAIN32	CHAIN10
Reset	0	0	0	0	0	0	0	0
R/W	R/W	R/W	R/W	R/W	R	R/W	R/W	R/W
Address	FB0h							

Bit	Description
[7] GDISABLE	<p>DMA Global Disable</p> <p>Any enabled DMA channel will resume when GDISABLE is cleared to provide an efficient mechanism to pause all DMA channels, thereby quickly allowing the CPU full bandwidth of the Register Bus.</p> <p>0: DMA requests are enabled for those DMA channels that have ENABLE=1. 1: DMA requests are blocked for all DMA channels.</p>
[6] PRIORITY	<p>DMA Priority Select</p> <p>0: DMA executes channel requests using round robin priority. 1: DMA executes channel requests using fixed priority.</p>
[5:4] BURST	<p>Burst Transfers</p> <p>00: Block. DMA will burst transfer the entire block of data if the DMA request remains asserted. 01: Burst 4. DMA will limit burst transfer length to bursts of 4 transfers if the DMA request remains asserted. 10: Single. DMA will limit burst transfer length to a single transfer even if DMA request remains asserted. 11: Reserved.</p>
[3]	<p>Reserved</p> <p>This bit is reserved and must be programmed to 0.</p>
[2] AUTOINC	<p>Autoincrement Enable</p> <p>Clear AUTOINC before executing an instruction to manipulate bits in a DMA subregister, such as AND, BIT, and OR.</p> <p>0: Autoincrement is disabled. 1: Autoincrement is enabled.</p>

Bit	Description (Continued)
[1] CHAIN32	Chain DMA3 and DMA2 0: DMA3 and DMA2 are independent of each other. 1: DMA3 and DMA2 are chained together, as described in the Chain Operation section on page 394.
[0] CHAIN10	Chain DMA1 and DMA0 0: DMA1 and DMA0 are independent of each other. 1: DMA1 and DMA0 are chained together, as described in the Chain Operation section on page 394.

18.3.4. DMA Source Address Subregisters

The DMAxSRCH and DMAxSRCL subregisters, shown in Tables 207 and 208, combine to form the 12-bit source address for the DMA transaction. Upon each byte transfer, the source address is updated based on the SRCCTL configuration in the DMAx Control 0 Subregister. In addition, DMAxSRCH contains transfer in list (TXLIST) control.

Table 207. DMA Source Address High Subregister (DMAxSRCH)

Bit	7	6	5	4	3	2	1	0
Field	TXLIST	Reserved			SRCH			
Reset	0	0	0	0	0	0	0	0
R/W	R	R	R	R	R/W	R/W	R/W	R/W
Address	If DMA _{SA} = 0h in the DMA _{SA} Register, accessible through the DMA 0–3 Subregister							

Bit	Description
[7] TXLIST	Transfer In List TXLIST has an effect only during linked list operation, see the Linked List Control Options section on page 396 for details.
[6:4]	Reserved These bits are reserved and must be programmed to 000.
[3:0] SRCH	Source Address High 0–F: Upper 4 bits of the DMA source address.

Table 208. DMA Source Address Low Subregister (DMAxSRCL)

Bit	7	6	5	4	3	2	1	0
Field	SRCL							
Reset	0	0	0	0	0	0	0	0
R/W	R/W	R/W	R/W	R/W	R/W	R/W	R/W	R/W
Address	If DMASA = 1h in the DMAxSA Register, accessible through the DMA 0–3 Subregister							

Bit	Description
[7:0] SRCL	Source Address Low 00–FF: Lower 8-bits of the DMA source address.

18.3.5. DMA Destination Address Subregisters

The DMAxDSTH and DMAxDSTL subregisters, shown in Tables 209 and 210, combine to form the 12-bit destination address for the DMA transaction. Upon each byte transfer, the destination address is updated based on the DSTCTL configuration in the DMAx Control 0 Subregister.

Table 209. DMA Destination Address High Subregister (DMAxDSTH)

Bit	7	6	5	4	3	2	1	0
Field	Reserved				DSTH			
Reset	0	0	0	0	0	0	0	0
R/W	R	R	R	R	R/W	R/W	R/W	R/W
Address	If DMASA = 2h in the DMAxSA Register, accessible through the DMA 0–3 Subregister							

Bit	Description
[7:4]	Reserved These bits are reserved and must be programmed to 0000.
[3:0] DSTH	Destination Address High 0–F: Upper 4 bits of the DMA destination address.

Table 210. DMA Destination Address Low Subregister (DMAxDSTL)

Bit	7	6	5	4	3	2	1	0
Field	DSTL							
Reset	0	0	0	0	0	0	0	0
R/W	R/W	R/W	R/W	R/W	R/W	R/W	R/W	R/W
Address	If DMASA = 3h in the DMAxSA Register, accessible through the DMA 0–3 Subregister							

Bit	Description
[7:0] DSTL	Destination Address Low 00–FF: Lower 8 bits of the DMA destination address.

18.3.6. DMA Count Subregisters

The DMAxCNTH and DMAxCNTL subregisters, shown in Tables 211 and 212, combine to form the transfer count length in bytes for the DMA transaction. Upon each byte transfer, the count is decremented. DMAxCNTH also contains the watermark selection.

Table 211. DMA Count Subregister High (DMAxCNTH)

Bit	7	6	5	4	3	2	1	0
Field	WMCNT				CNTH			
Reset	0	0	0	0	0	0	0	0
R/W	R/W	R/W	R/W	R/W	R/W	R/W	R/W	R/W
Address	If DMASA = 4h in the DMAxSA Register, accessible through the DMA 0–3 Subregister							

Bit	Description
[7:4]	Watermark Count
WMCNT	0000: Watermark interrupt disabled. 0001: Watermark interrupt when 1 byte remains. 0010: Watermark interrupt when 4 bytes remain. 0011: Watermark interrupt when 8 bytes remain. 0100: Watermark interrupt when 12 bytes remain. 0101: Watermark interrupt when 16 bytes remain. 0110: Watermark interrupt when 20 bytes remain. 0111: Watermark interrupt when 24 bytes remain. 1000: Watermark interrupt when 28 bytes remain. 1001: Watermark interrupt when 32 bytes remain. 1010: Watermark interrupt when 36 bytes remain. 1011: Watermark interrupt when 40 bytes remain. 1100: Watermark interrupt when 44 bytes remain. 1101: Watermark interrupt when 48 bytes remain. 1110: Watermark interrupt when 52 bytes remain. 1111: Watermark interrupt when 56 bytes remain.
[3:0]	Count High
CNTH	0–F: Upper 4 bits of the DMA transfer count.

Table 212. DMA Count Subregister Low (DMAxCNTL)

Bit	7	6	5	4	3	2	1	0
Field	CNTL							
Reset	0	0	0	0	0	0	0	0
R/W	R/W	R/W	R/W	R/W	R/W	R/W	R/W	R/W
Address	If DMASA = 5h in the DMAxSA Register, accessible through the DMA 0–3 Subregister							

Bit	Description
[7:0] CNTL	Count Low 00–FF: Lower 8 bits of the DMA transfer count.

18.3.7. DMA 0–3 Control 0 Subregisters

The DMA Control 0 subregisters, shown in Table 213, contains control of the DMA channel.

Table 213. DMA 0–3 Control 0 Subregisters (DMAxCTL0)

Bit	7	6	5	4	3	2	1	0
Field	LLCTL		EOCIRQE	HALT	DSTCTL		SRCCTL	
Reset	0	0	0	0	0	0	0	0
R/W	R/W	R/W	R/W	R/W	R/W	R/W	R/W	R/W
Address	If DMASA = 6h in the DMAxSA Register, accessible through the DMA 0–3 Subregister							

Bit	Description
[7:6] LLCTL	Linked List Control LLCTL has an effect only during linked list operation. 00: Normal linked list operation with status write and without repeat descriptor. 01: Repeat descriptor. DMA will not overwrite the DMA descriptor nor increment the linked list descriptor address {LAH, LAL}. 10: No status write. DMA will not overwrite the DMA descriptor. 11: Reserved.
[5] EOCIRQE	End-of-Count Interrupt Request Enable 0: No interrupt is generated when end-of-count is reached. 1: An interrupt is generated when end-of-count is reached.
[4] HALT	Halt Upon Descriptor Completion HALT has an effect only in linked list operation. 0: Except when LLCTL=01 (repeat descriptor), 8 is added to the linked list descriptor address {LAH, LAL} upon completion of this descriptor and the next descriptor is loaded. 1: Halt when this descriptor is finished and disable this DMA channel without adding 8 to the linked list descriptor address {LAH, LAL}.

Bit	Description (Continued)
[3:2] DSTCTL	Destination Address Control 00: Fixed. 01: Increment. 10: Decrement. 11: Fixed word.
[1:0] SRCCTL	Source Address Control 00: Fixed. 01: Increment. 10: Decrement. 11: Fixed word.

18.3.8. DMA 0–3 Control 1 Subregisters

The DMA Control 0 subregisters, shown in Table 214, contains enable control and DMA requestor selection for the DMA channel.

Table 214. DMA 0–3 Control 1 Subregisters (DMAxCTL1)

Bit	7	6	5	4	3	2	1	0
Field	ENABLE	Reserved			REQSEL			
Reset	0	0	0	0	0	0	0	0
R/W	R/W	R/W	R/W	R/W	R/W	R/W	R/W	R/W
Address	If DMASA = 7h in the DMAxSA Register, accessible through the DMA 0–3 Subregister							

Bit	Description
[7] ENABLE	DMA Channel Enable This bit is cleared when DMA reaches end-of-count (EOC). 0: DMAx is disabled. 1: DMAx is enabled.
[6:5]	Reserved These bits are reserved and must be programmed to 00.

Bit	Description (Continued)
[4:0]	DMA Requestor Selection
REQSEL	00000: Software. DMA service is requested upon enabling DMA.
	00001: Reserved.
	00010: SPI0 RX.
	00011: SPI0 TX.
	00100: SPI1 RX.
	00101: SPI1 TX.
	00110: USB DMA0.
	00111: USB DMA1.
	01000: AES RX.
	01001: AES TX.
	01010: UART0 RX.
	01011: UART0 TX.
	01100: UART1 RX.
	01101: UART1 TX.
	01110: I ² C RX.
	01111: I ² C TX.
	10000: ADC.
	10001: DAC.
	10010: Timer 0.
	10011: Timer 1.
	10100: Timer 2.
	10101: Multi-channel Timer channel A.
	10110: Multi-channel Timer channel B.
	10111: Multi-channel Timer channel C.
	11000: Multi-channel Timer channel D.
	Others: Reserved.

18.3.9. DMA 0–3 Linked List Descriptor Address High and Low Subregisters

The DMA Linked List Descriptor Address High and Low (DMAxLAH and DMAxLAL) subregisters, shown in Tables 215 and 216, contain the 12-bit linked list descriptor address. These registers have an effect only during linked list operation. Writing DMAxLAL automatically starts the Linked List DMAx even if DMAxLAH is not written.

Table 215. DMA 0–3 Linked List Descriptor Address High Subregister (DMAxLAH)

Bit	7	6	5	4	3	2	1	0
Field	Reserved				LAH			
Reset	0	0	0	0	0	0	0	0
R/W	R	R	R	R	R/W	R/W	R/W	R/W
Address	If DMASA = 8h in the DMAxSA Register, accessible through the DMA 0–3 Subregister							

Bit	Description
[7:4]	Reserved These bits are reserved and must be programmed to 0000.
[3:0] LAH	Linked List Descriptor Address High LAH and LAL together form the 12-bit address that points to the current linked list descriptor. 0–F: The upper 4 bits of the linked list descriptor address.

Table 216. DMA 0–3 Linked List Descriptor Address Low Subregister (DMAxLAL)

Bit	7	6	5	4	3	2	1	0
Field	LAL							
Reset	0	0	0	0	0	0	0	0
R/W	R/W	R/W	R/W	R/W	R/W	R	R	R
Address	If DMASA = 9h in the DMAxSA Register, accessible through the DMA 0–3 Subregister							

Bit	Description
[7:0] LAL	Linked List Descriptor Address Low LAH and LAL together form the a 12-bit address that points to the current linked list descriptor. As descriptors are aligned on 8-byte address boundaries, the lower three bits of LAL cannot be written, and are always zero. Writing to this DMAxLAL Register automatically starts the linked list DMA operation. A write to DMAxLAH is not required to start linked list operation. 00–F8: The lower 8 bits of the linked list descriptor address.

Chapter 19. Event System

The F6482 Series devices provide an eight-channel Event System that can route up to eight signals independent of any CPU or DMA activity. Any Event System source can be selected to drive a signal on an Event System channel.

These Event System sources are:

- Software
- Timers
- Multi-Channel Timer
- Real Time Clock (RTC)
- Comparators
- GPIO

Event System Destinations:

- Timers
- Multi-Channel Timer
- Real Time Clock (RTC)
- ADC
- DAC
- GPIO

The Event System is active in all operating modes, including Stop Mode.

19.1. Architecture

This chapter discusses the Event System, including Event System sources, channels, and destinations. A diagram of the Event System is shown in Figure 61.

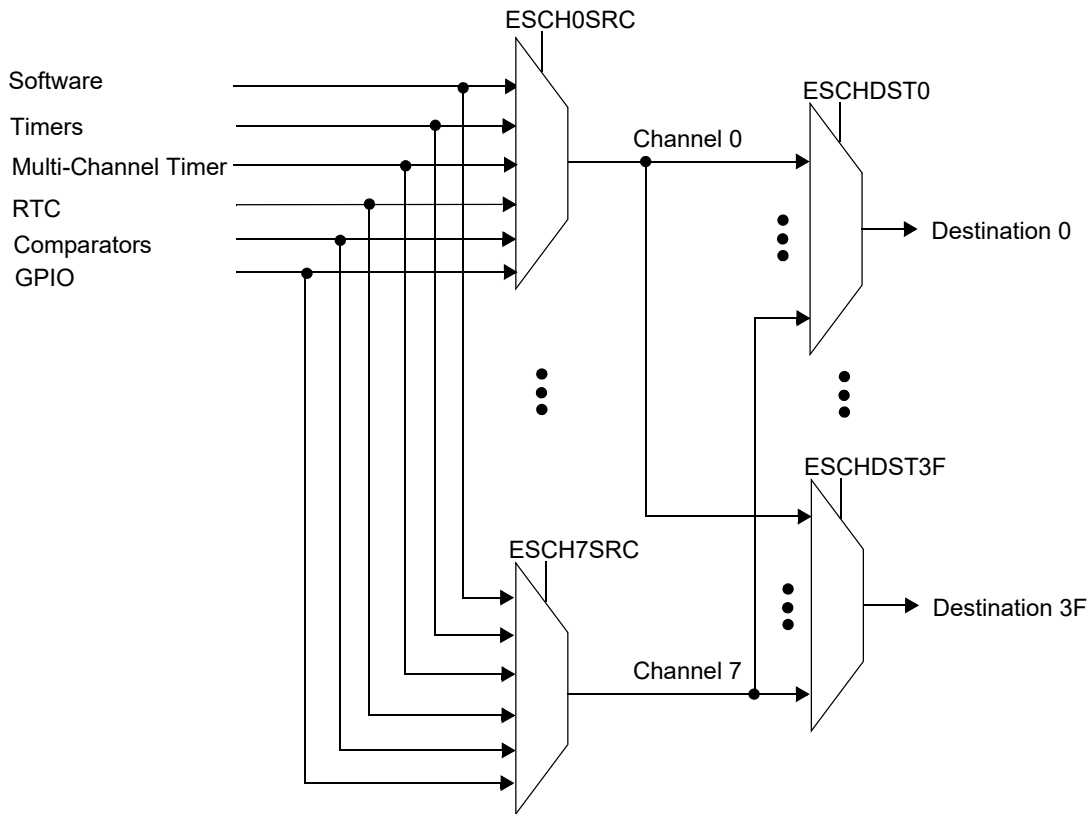

Figure 61. Event System Block Diagram

The Event System provides autonomous communication between peripherals, independently of any CPU or DMA activity. The Event System is available in all operating modes, including Stop Mode, to allow for the energy-efficient triggering of peripherals. Furthermore, the direct peripheral-to-peripheral communication reduces software overhead, and allows critical timing signals to pass directly without incurring interrupt latencies.

The Event System can route up to eight signals simultaneously. An event system channel is enabled by writing a nonzero value to the corresponding ESCHxSRC Subregister. Each Event System channel can service one or more destinations.

19.2. Source Selection

The Channel Source subregisters, ESCHxSRC, are used to enable Event System channels, and to select each channel signal source with CHSRCSEL. When enabled, each Event System channel is driven by a single, selectable signal source.

A variety of peripherals and GPIOs can be selected to be an Event System channel signal source. In addition, software can assert a channel (High) by writing CHSRCSEL=01h. In this case, the channel will remain asserted (High) until CHSRCSEL is written with a value other than 01h. When selecting a GPIO as an Event System channel signal source, no additional configuration of the GPIO port alternate function selection registers is required.

The ESCHxSRC subregisters are accessed using the Event System Source Subaddress Register (ESSSA) and Event System Source Subdata Register (ESSSD). An ESCHxSRC Subregister is selected by ESSSA in the ESSSA Register and is accessed by writing/reading ESSSD in the ESSSD Register.

Table 217 lists the available Event System signal sources.

Table 217. Event System Signal Sources

Peripheral	Output Signal
Software	ESCHxCTL=01h
Timer 0	Timer 0 out
	$\overline{\text{Timer 0 out}}$
Timer 1	Timer 1 out
	$\overline{\text{Timer 1 out}}$
Timer 2	Timer 2 out
	$\overline{\text{Timer 2 out}}$
Multi-Channel Timer	Multi-Channel Timer out A
	Multi-Channel Timer out B
	Multi-Channel Timer out C
	Multi-Channel Timer out D
RTC	Prescaled clock
	Alarm
Comparator 0	Comparator 0 out
Comparator 1	Comparator 1 out
Comparator 0/1	Comparator 0/1 window detection (C01)
Port A	Port A[7:0] pin
Port C	Port C[7:4] pin
Port E	Port E[6:3] pin

19.3. Destination Selection

A variety of peripherals and GPIOs can be selected to be a destination for an Event System channel. Connecting a destination to an Event System channel is controlled in the Event System Destination Channel subregisters, ESDSTxCH. If DSTCON in the ESDSTxCH Subregister is set, the destination is connected to the Event System channel specified in DSTCHSEL; otherwise, the destination is connected to logic 0. Because each destination can connect to any Event System channel, multiple peripherals can be a destination for the same Event System channel.

The ESDSTxCH subregisters are accessed using the Event System Destination Subaddress Register (ESDSA) and the Event System Destination Subdata Register (ESDSD). An ESDSTxCH Subregister is selected by ESDSD in the ESDSA Register, and is accessed by writing/reading the ESDSD bit in the ESDSD Register.

Table 218 lists the Event System destinations.

Table 218. Event System Destinations

Peripheral	Signal Connection
Timer 0	Input 0
	Input 1
Timer 1	Input 0
	Input 1
Timer 2	Input 0
	Input 1
Multi-Channel Timer	Multi-Channel Timer in A
	Multi-Channel Timer in B
	Multi-Channel Timer in C
	Multi-Channel Timer in D
	Multi-Channel Timer in
RTC	RTC Source Select
ADC	Convert
DAC	Convert
Port C	Port C[7:6] pins using ESOUT [1:0]
Port E	Port E[6:3] pins using ESOUT [3:0]
Port F	Port F[3:0] pins using ESOUT [3:0]

Four Event System GPIO outputs, ESOUT[3:0], are available to the port pins listed in Table 218. The GPIO PxAF, PxAFS1, and PxAFS2 subregisters select the Event System

output, ESOUT[3:0], that is available for a particular port pin. See the [General-Purpose Input/Output](#) chapter on page 55 to learn more regarding alternate function selection.

19.4. Timing Considerations

The Event System essentially performs a multiplexing function. Signals sourced to Event System channels do not go through a synchronization process within the Event System. As such, the signals on Event System channels must be sufficient in duration for detection by their corresponding destinations. Any source and destination pair that are using the same clock, one of SYSCLK, PCLK, or the WTO, can be connected to each other via the Event System without concern about source signal duration. When the Event System source and destination pair are using dissimilar clocks, the Event System source signal should be at least 1.5 times the duration of the clock period of the Event System destination to assure that the destination will detect the signal from the source.

19.5. Event System Usage Examples

To illustrate the usage of the Event System, let's examine the following two examples.

Example 1: Triggering Periodic ADC Conversions Using a Timer. In this example, a timer serves as the signal source to Event System channel 0 and the this channel is selected to trigger ADC conversions.

- Select Timer 0 out as the signal source for Event System channel 0, as follows:
 - Write 00h to the ESSSA Register to select the ESCH0SRC Subregister.
 - Write 10h to the ESSSD Register. This accesses the ESCH0SRC Subregister to select Timer 0 out as the Event System channel 0 source.
- Configure the ADC conversion parameters. For instance, the ADC could be configured with a window function such that interrupts are generated only when the window is exceeded.
- If a DMA is desired, configure the DMA Controller to transfer the ADC results to memory.
- Configure the ADC to respond to Event System channel 0, as follows:
 - Write 04h to the ESDSA Register to select the ESDST04CH Subregister.
 - Write 08h to the ESDSD Register. This accesses ESDST04CH Subregister to enable Event System connection to the ADC and to select channel 0 as input to the ADC.

- Set Timer 0 to Counter Mode with half the desired ADC conversion periodicity, then enable Timer 0. Each Timer 0 Out rising edge will be detected by the ADC, resulting in a new ADC conversion.

Example 2: Observing a Event System Channel on a GPIO. This example builds on the previous example by additionally routing Event System channel 0 to GPIO Port C7.

- Select Timer 0 out as the signal source for channel 0, as follows:
 - Write 00h to the ESSSA Register to select the ESCH0SRC Subregister.
 - Write 10h to the ESSSD Register. This accesses ESCH0SRC Subregister to select Timer 0 out as the Event System channel 0 source.
- Configure the ADC conversion parameters. For instance, the ADC could be configured with a window function such that interrupts are generated only when the window is exceeded.
- If DMA is desired, configure the DMA Controller to transfer the ADC results to memory.
- Configure the ADC to respond to Event System channel 0, as follows:
 - Write 04h to the ESDSA Register to select the ESDST04CH Subregister.
 - Write 08h to the ESDSD Register. This accesses the ESDST04CH Subregister to enable Event System connection to the ADC and to select channel 0 as input to the ADC.
- Configure Port C7 to respond to Event System channel 0, as follows:
 - Write 02h to the GPIO PCADDR Register to select the PCAF Subregister.
 - Write 80h to the GPIO PCCTL Register to enable alternate function for Port C7.
 - Write 07h to the GPIO PCADDR Register to select the PCAFS1 Subregister.
 - Write 00h to the GPIO PCCTL Register as partial selection of ESOUT[1] for Port C7.
 - Write 08h to the GPIO PCADDR Register to select the PCAFS2 Subregister.
 - Write 80h to the GPIO PCCTL Register to complete selection of ESOUT[1] for Port C7.
 - Write 31h to the ESDSA Register to select the ESDST31CH Subregister.
 - Write 08h to the ESDSD Register. This accesses the ESDST31CH Subregister to enable Event System connection to the ESOUT[1] and to select channel 0 as input to ESOUT[1].
- Configure Timer 0 to Counter Mode with half the desired ADC conversion periodicity, then enable Timer 0. Each Timer 0 Out rising edge will be detected by the ADC, resulting in a new ADC conversion; the Timer 0 Out signal will be available on Port C7.

19.6. Event System Register Definitions

Four register addresses provide access to the Event System subregisters that control source and destination selection for each Event System channel. Table 219 lists these Event System registers and subregisters.

Table 219. Event System Registers and Subregisters

Event System Source Selection Registers and Subregisters		
Register Mnemonic	Address	Register Name
ESSSA	F98h	Event System Source Subaddress Register
ESSSD	F99h	Event System Source Subdata Register
Subregister Mnemonic	Subregister Address*	Subregister Name
ESCHxSRC	0–7h	Event System Channel 0–7 Source subregisters
Event System Destination Selection Registers and Subregisters		
Register Mnemonic	Address	Register Name
ESDSA	F9Ah	Event System Destination Subaddress Register
ESDSD	F9Bh	Event System Destination Subdata Register
Subregister Mnemonic	Subregister Address*	Subregister Name
ESCHDSTx	0–3Fh	Event System Destination 0–3F Channel subregisters

Note: *The ESSSA Register contains the ESCHxSRC Subregister address; the ESDSA Register contains the ESCHDSTx Subregister address.

19.6.1. Event System Source Subaddress Register

The Event System Source Subaddress Register (ESSSA), shown in Table 220, selects the Channel Source Subregister (ESCHxSRC) that is accessible through the Event System Source Subdata Register (ESSSD).

Table 220. Event System Source Subaddress Register (ESSSA)

Bit	7	6	5	4	3	2	1	0
Field	Reserved					ESSSA		
Reset	0	0	0	0	0	0	0	0
R/W	R	R	R	R	R	R/W	R/W	R/W
Address	F98h							

Bit	Description
[7:4]	Reserved These bits are reserved and must be programmed to 0000.
[3:0] ESSSA	Event System Source Subaddress for Channel Source Selection 000=Channel 0. 001=Channel 1. 010=Channel 2. 011=Channel 3. 100=Channel 4. 101=Channel 5. 110=Channel 6. 111=Channel 7.

19.6.2. Event System Source Subdata Register

The Event System Source Subdata Register (ESSSD), shown in Table 221, sets Channel Source Subregister (ESCHxSRC) operation. The value in the ESSSA Register determines which ESCHxSRC subregister is accessed.

Table 221. Event System Source Subdata Register (ESSSD)

Bit	7	6	5	4	3	2	1	0
Field	Reserved	ESSSD						
Reset	0	0	0	0	0	0	0	0
R/W	R	R/W	R/W	R/W	R/W	R/W	R/W	R/W
Address	F99h							

Bit	Description
[7]	Reserved This bit is reserved and must be programmed to 0.
[6:0]	Event System Source Subregister Data ESSSD

19.6.3. Event System Channel 0–7 Source Subregisters

The Event System Channel 0–7 Source (ESCHxSRC) subregisters, shown in Table 222, enable the channel and select the source that drives the channel.

Table 222. Event System Channel 0–7 Source Subregisters (ESCHxSRC)

Bit	7	6	5	4	3	2	1	0
Field	Reserved	CHSRCSEL						
Reset	0	0	0	0	0	0	0	0
R/W	R	R/W	R/W	R/W	R/W	R/W	R/W	R/W
Address	If 00h–07h in Event System Source Subaddress Register, accessible through the Event System Source Subdata Register							

Bit	Description
[7]	Reserved This bit is reserved and must be programmed to 0.
[6:0]	Event System Channel Source Selection CHSRCSEL 00h: Channel Disabled (Low). 01h: Software assertion (High). The channel remains asserted (High) until a different source is selected. 02h–0Fh: Reserved. 10h: <u>Timer 0 out</u> . 11h: <u>Timer 0 out</u> . 12h–13h: Reserved. 14h: <u>Timer 1 out</u> . 15h: <u>Timer 1 out</u> . 16h–17h: Reserved. 18h: <u>Timer 2 out</u> . 19h: <u>Timer 2 out</u> . 1Ah–1Bh: Reserved. 1Ch: Multi-Channel Timer Output A. 1Dh: Multi-Channel Timer Output B. 1Eh: Multi-Channel Timer Output C. 1Fh: Multi-Channel Timer Output D. 20h–2Bh: Reserved. 2Ch: RTC Alarm. 2Dh: RTC prescaled clock. 2Eh–3Fh: Reserved. 40h: Comparator 0 out. 41h: Comparator 1 out. 42h: Comparator 0/1 window detection (C01). 43h–4Fh: Reserved. 50h: Port A [0] pin. 51h: Port A [1] pin. 52h: Port A [2] pin.

Bit	Description (Continued)
[6:0]	53h: Port A [3] pin.
CHSRCSEL	54h: Port A [4] pin.
(cont'd.)	55h: Port A [5] pin.
	56h: Port A [6] pin.
	57h: Port A [7] pin.
	58h–63h: Reserved.
	64h: Port C [4] pin.
	65h: Port C [5] pin.
	66h: Port C [6] pin.
	67h: Port C [7] pin.
	68h–72h: Reserved.
	73h: Port E [3] pin.
	74h: Port E [4] pin.
	75h: Port E [5] pin.
	76h: Port E [6] pin.
	77h–7Fh: Reserved.

19.6.4. Event System Destination Subaddress Register

The Event System Destination Subaddress Register (ESDSA), shown in Table 223, selects the Event System Destination 0–3F Channel Subregister (ESDSTxCH) that is accessible through the Event System Destination Subdata Register (ESDSD).

Table 223. Event System Destination Subaddress Register (ESDSA)

Bit	7	6	5	4	3	2	1	0
Field	Reserved		ESDSA					
Reset	0	0	0	0	0	0	0	0
R/W	R	R	R/W	R/W	R/W	R/W	R/W	R/W
Address	F9Ah							

Bit	Description
[7:6]	Reserved This bit is reserved and must be programmed to 0.
[5:0]	Event System Destination Subaddress for Destination Selection
ESDSA	00h–03h: Reserved. 04h: ADC convert input. 05h–07h: Reserved. 08h: DAC convert input. 09h–0Fh: Reserved. 10h: Timer 0 input 0. 11h: Timer 0 input 1. 12h–13h: Reserved.

Bit	Description (Continued)
[5:0]	14h: Timer 1 input 0.
ESDSA	15h: Timer 1 input 1.
(cont'd.)	16h–17h: Reserved.
	18h: Timer 2 input 0.
	19h: Timer 2 input 1.
	1Ah–1Bh: Reserved.
	1Ch: Multi-Channel Timer Input A.
	1Dh: Multi-Channel Timer Input B.
	1Eh: Multi-Channel Timer Input C.
	1Fh: Multi-Channel Timer Input D.
	20h: Multi-Channel Timer Input.
	21h–2Bh: Reserved.
	2Ch: RTC Source Select.
	2Dh–2Fh: Reserved.
	30h: ESOUT[0]. Event System GPIO Out 0.
	31h: ESOUT[1]. Event System GPIO Out 1.
	32h: ESOUT[2]. Event System GPIO Out 2.
	33h: ESOUT[3]. Event System GPIO Out 3.
	34h–3Fh: Reserved.

19.6.5. Event System Destination Subdata Register

The Event System Destination Subdata Register (ESDSD), shown in Table 224, sets the Event System Destination 0–3F Channel Subregister (ESDSTxCH) operation. The value in the ESDSA Register determines which ESDSTxCH Subregister is accessed.

Table 224. Event System Destination Subdata Register (ESDSD)

Bit	7	6	5	4	3	2	1	0
Field	Reserved				ESDSD			
Reset	0	0	0	0	0	0	0	0
R/W	R	R	R	R	R/W	R/W	R/W	R/W
Address	F9Bh							

Bit	Description
[7:4]	Reserved This bit is reserved and must be programmed to 0.
[3:0]	Event System Destination Subregister Data ESDSD

19.6.6. Event System Destination 0–3F Channel Subregisters

The Event System Destination 0–3F Channel (ESDSTxCH) subregisters, shown in Table 225, determine whether each destination is connected to the Event System and select the Event System channel to connect to the destination.

Table 225. Event System Destination 0–3F Channel Subregisters (ESDSTxCH)

Bit	7	6	5	4	3	2	1	0
Field	Reserved				DSTCON	DSTCHSEL		
Reset	0	0	0	0	0	0	0	0
R/W	R	R	R	R	R/W	R/W	R/W	R/W
Address	If 00h -3Fh in Event System Destination Subaddress Register, accessible through the Event System Destination Subdata Register							

Bit	Description
[7:4]	Reserved This bit is reserved and must be programmed to 0.
[3] DSTCON	Event System Destination Connection 0: The selected Event System channel is not connected to the addressed destination. The destination is connected to logic 0. 1: The selected Event System channel is connected to the addressed destination.
[2:0] DSTCHSEL	Event System Destination Channel Selection 000: Channel 0 is connected to the destination if DSTCON=1. 001: Channel 1 is connected to the destination if DSTCON=1. 010: Channel 2 is connected to the destination if DSTCON=1. 011: Channel 3 is connected to the destination if DSTCON=1. 100: Channel 4 is connected to the destination if DSTCON=1. 101: Channel 5 is connected to the destination if DSTCON=1. 110: Channel 6 is connected to the destination if DSTCON=1. 111: Channel 7 is connected to the destination if DSTCON=1.

Chapter 20. Advanced Encryption Standard (AES) Accelerator

F6482 Series MCUs are equipped with an AES accelerator that implements the *Rijndael cipher encoding and decoding algorithm* in compliance with the NIST Advanced Encryption Standard. It processes 128-bit data blocks with a 128-bit key. In addition to an Electronic Codebook mode, NIST Cipher Block Chaining and Output Feedback modes are also supported. An automatic start feature facilitates use with the DMA Controller, and applications can be configured to be interrupted upon completion or error.

This AES accelerator includes the following features:

- Encrypts and decrypts using the AES Rijndael Block Cipher Algorithm
- Based on Federal Information Processing Standard (FIPS) Publication 197 from the US National Institute of Standards and Technology (NIST)
- Processes 128-bit data blocks with an 8-bit data interface
- Contains a dedicated 128-bit key buffer
- Supports the NIST OFB and CBC confidentiality modes (a *software assist* is required for decryption)
- DMA support for all modes of operation

20.1. AES Architecture

The AES accelerator implements Electronic Codebook (ECB) encryption or decryption on 128-bit data blocks. In addition to ECB encryption and decryption, the AES accelerator also provides a *hardware assist* feature for Output Feedback (OFB) and Cipher Block Chaining (CBC) modes; a software assist is required for decryption.

AES encryption is performed as defined in the [FIPS-197 Specification](#). The Cipher Block Chaining (CBC) and Output Feedback (OFB) modes are described in the [SP 800-38A Specification](#).

A block diagram of the AES accelerator is shown in Figure 62.

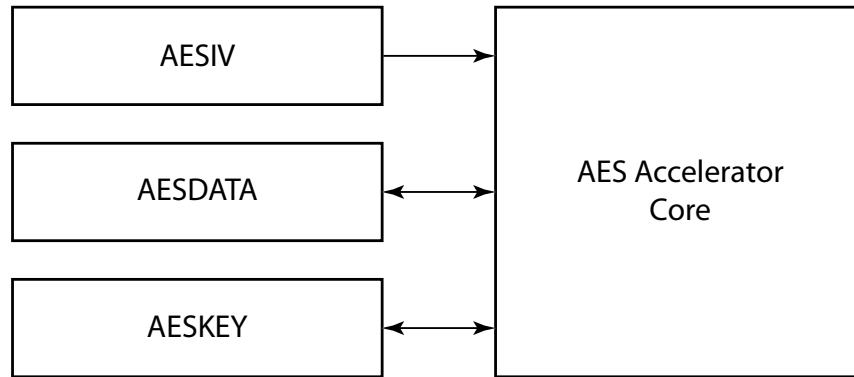

Figure 62. AES Accelerator Block Diagram

20.2. AES Operation

Encryption and decryption operations are inverses of each other. Encryption transforms readable *plain text* to secure *cipher text*. Decryption transforms secure cipher text into readable plain text. Encryption is performed in 160 clock cycles, and decryption is performed in 176 clock cycles.

To prepare for an encryption or decryption operation, configure the AES using the AESCTRL Register to perform the desired encryption/decryption operation, then load the AESKEY Register with the encryption or decryption key starting with the most significant byte (associated with $s(0,0)$ in Figure 63). If CBC or OFB modes are being used the Initialization Vector must be loaded in the AESIV Register before loading the data in the AESDATA Register. Plain Text or cipher text data is then written to the AESDATA Register. Loading the key, Initialization Vector or data must consist of 16 sequential byte writes to the respective register. If the block of data is not 128 bits, the user must pad the block to be 128 bits. While writing a 16 byte sequence to the AESKEY, AESIV or AESDATA registers, access to registers other than these can be interspersed in the sequence.

Figure 63 shows the mapping of data input bytes and data output bytes to the AES state array whereby $in[0]$ is the first data byte written to the AESDATA Register and $out[0]$ is the first data byte read from the AESDATA Register after encryption/decryption.

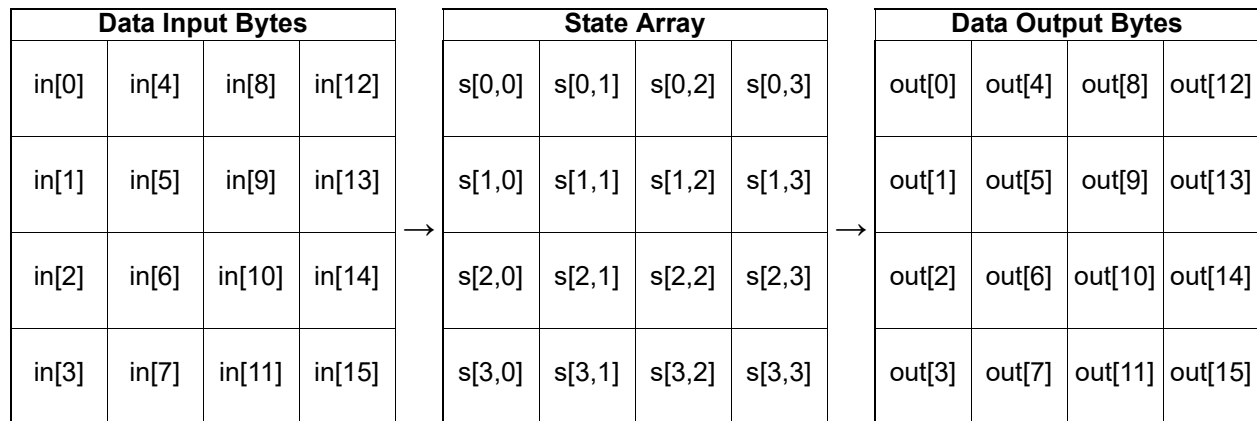

Figure 63. AES State Array Input and Output

Three status flags in the AESSTAT Register, KEYLD, IVLD and DATA LD, indicate whether the AES accelerator has been properly setup with the 16-byte loads of the AESKEY, AESIV and AESDATA registers. The IVLD flag is only applicable when using the CBC or OFB confidentiality modes. Disabling the AES accelerator clears the load status flags, IVLD, KEYLD and DATA LD. IVLD or KEYLD are also cleared during reloading of the respective registers. DATA LD is cleared upon completion of an encryption/decryption operation in conjunction with clearing START/BUSY in the AESCTL Register.

The encryption/decryption operation can be initiated either manually or with auto-start. Setting the START/BUSY bit will manually start the requested encryption/decryption regardless of the load status flag settings. If the AUTODIS bit is cleared, encryption/decryption will auto-start when the 16th byte of data is loaded only if the KEYLD and IVLD (if applicable) are set. Table 226 describes conditions required to auto-start:

Table 226. Register Bit Settings for Auto-Start

AUTODIS	Mode	IVLD	KEYLD	DATA LD	Auto-Start
0		0	X	X	NO
0	01 (OFB) or 10 (CBC)	0	0	X	NO
0		1	1	0	NO
0		1	1	1	YES
0		X	0	X	NO
0	00 (ECB)	X	1	0	NO
0		X	1	1	YES
1	X	X	X	X	NO

For both manual start and auto-start, while the accelerator is processing, the START/BUSY bit remains set. The AES accelerator will detect as an error any attempt to write the AESKEY, AESIV or AESDATA registers during an encryption/decryption operation and access attempts are blocked. The detection of an error does not affect the encryption/decryption operation but ERROR in the AESSTAT Register is set.

The completion of an encryption/decryption operation is indicated by the START/BUSY bit transition from one to zero. An interrupt will be generated if IRQ is set in the AESCTRL Register.

20.2.1. AES Operation and DMA

Two DMA requests are provided: RxIRQ for receive data, and TxIRQ for transmit data. The load status bits used to control DMA receive and transmit data requests. When AESEN is set and KEYLD=1, DATALD=0 and IVLD=1 (if applicable), RxIRQ is asserted for DMA data transfer. When the DMA Controller has written; i.e., 16 bytes to the AESDATA Register, if AUTODIS=0, the AES accelerator will start processing. If AUTODIS=1, processing can be started by setting START/BUSY. When encryption/decryption completes, START/BUSY is cleared, DATALD is cleared and the AES accelerator asserts TxIRQ. When 16 bytes are read from the AESDATA Register, TxIRQ is deasserted and RxIRQ is again asserted. This sequence will continue as long as the DMA Controller provides data to the AES accelerator. The message size is setup in the DMA configuration, as described in the [Direct Memory Access Controller](#) chapter on page 390. Table 227 summarizes DMA request conditions.

Table 227. Register Bit Settings for DMA Support, AUTODIS=0

Mode	START/ BUSY	IVLD	KEYLD	DATALD	RxIRQ	TxIRQ
01 (OFB) or 10 (CBC)	0	0	X	X	0	0
	0	0	0	X	0	0
	0	1	1	0	1	0
	1*	1	1	1	0	0
	1→0	1	1	1→0	0	1
00 (ECB)	0	X	0	X	0	0
	0	X	1	0	1	0
	1*	X	1	1	0	0
	1→0	X	1	1	0	1

Note: *If AUTODIS=1, START/BUSY must be set by software.

20.2.2. AES Electronic Codebook (ECB) Mode

The following subsections describe AES ECB Mode.

20.2.2.1. AES ECB Mode Description

AES ECB Mode is selected by configuring MODE=00 in the AES Control Register. To encrypt in this mode, the AES accelerator uses the encryption key to operate on plain text to generate cipher text. An ECB encryption flow diagram is shown in Figure 64, and an ECB encryption example is provided on the next page.

To decrypt in this mode, the AES accelerator uses the decryption key to operate on cipher text to generate plain text. See the ECB decryption flow diagram in Figure 65 and the example on the next page.

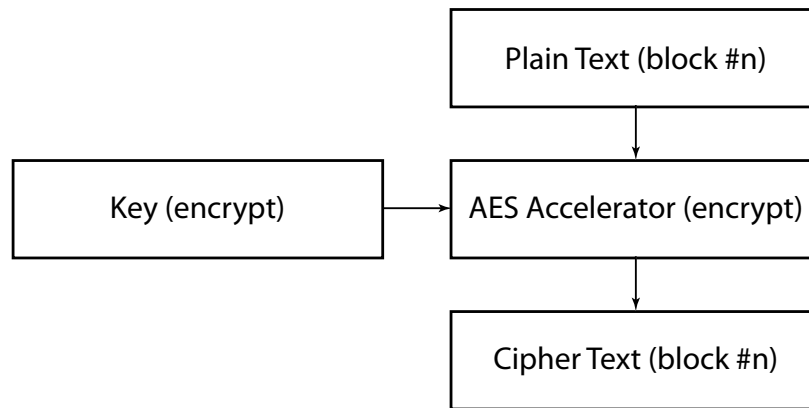

Figure 64. ECB Mode Encryption Flow Diagram

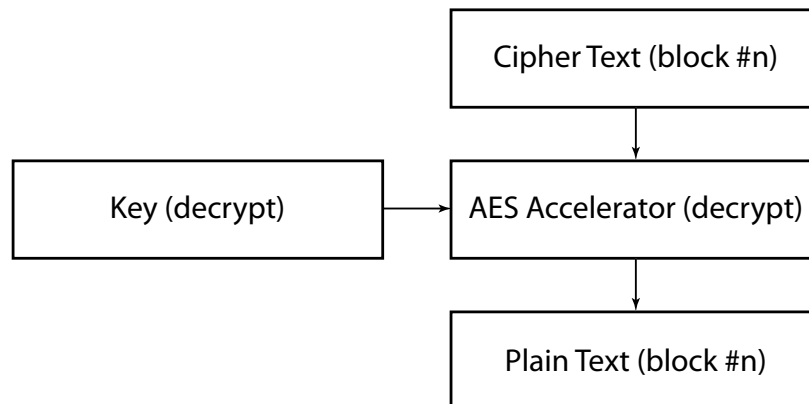

Figure 65. ECB Mode Decryption Flow Diagram

20.2.2.2. AES ECB Encryption Example

The following example outlines a procedure for performing AES encryption in ECB Mode.

1. Write the AESCTRL Register as follows: AES_EN=1, MODE=00 (ECB), DECRYPT=0, AUTODIS=1.
2. Write the AESKEY Register with the encryption key.
3. Write plain text to the AESDATA Register or use DMA.
4. Set START/BUSY in the AESSTAT Register or use auto-start, AUTODIS=0 in step 1.
5. Poll START/BUSY or use interrupt.
6. Read cipher text from the AESDATA Register or use DMA.
7. Repeat steps 3 through 6 for additional blocks.

20.2.2.3. AES ECB Decryption Example

The following example outlines a procedure for performing AES decryption in ECB Mode.

1. Write the AESCTRL Register as follows: AES_EN=1, MODE=00 (ECB), DECRYPT=1, AUTODIS=1.
2. Write the AESKEY Register with the decryption (R[10]) key.
3. Write cipher text to the AESDATA Register or use DMA.
4. Set START/BUSY in the AESSTAT Register or use auto-start, AUTODIS=0 in step 1.
5. Poll START/BUSY bit or use interrupt.
6. Read the plain text from the AESDATA Register or use DMA.
7. Repeat steps 3 through 6 for additional blocks.

20.2.3. Initialization Vector

When using CBC Mode or OFB Mode, the Initialization Vector must be loaded before encryption/decryption by setting IVEN=1 and writing the Initialization Vector to the AESIV Register. The successful 16 byte load of the Initialization Vector is indicated by the IVLD=1 in the AESSTAT Register. The Initialization Vector load must be completed before using the DMA Controller to perform AESDATA Register accesses. Loading the Initialization Vector is a one-time setup that must be completed before the CBC or OFB mode can be used. However, if the AES becomes disabled (AESEN=0), KEYLD and IVLD will be cleared, and the AESKEY and AESIV registers must be reloaded to again set KEYLD and IVLD as required for auto-start (AUTODIS=0).

20.2.4. AES Output Feedback (OFB) Mode

The following subsections describe AES OFB Mode.

20.2.4.1. AES CBC Mode Description

AES OFB Mode is selected by configuring MODE=01 in the AES Control Register. To encrypt in this mode, the AES accelerator uses the encryption key to operate on the previous AES accelerator output which is then XORed with plain text to generate cipher text. Because the previous AES accelerator output is not available for the first operation, an Initialization Vector is utilized instead. An OFB encryption flow diagram is shown in Figure 66 and an OFB encryption example is provided in the [OFB Mode Encryption Example](#) section on page 431.

To decrypt in this mode, the AES accelerator uses the decryption key to operate on the previous AES accelerator output which is then XORed with cipher text to generate plain text. Because the previous AES accelerator output is not available for the first operation, an Initialization Vector is utilized instead. Both encryption and decryption for OFB Mode require the AES accelerator to be set to encrypt (DECRYPT=0). An OFB encryption flow diagram is shown in Figure 67.

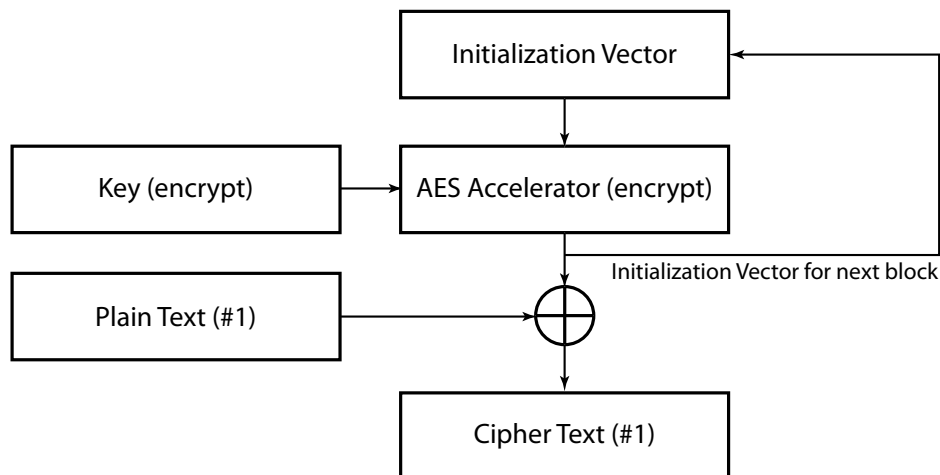

Figure 66. OFB Mode Encryption Flow Diagram

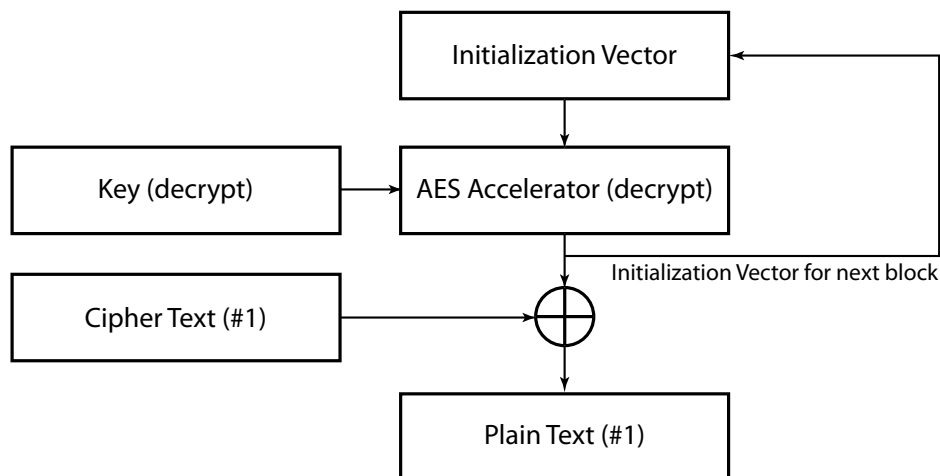

Figure 67. OFB Mode Decryption Flow Diagram

20.2.4.2. OFB Mode Encryption Example

The following steps are required to support OFB Mode encryption operation.

1. Write the AESCTRL Register as follows: AES_EN=1, MODE=01 (OFB), DECRYPT=0, AUTODIS=1.
2. Write the AESKEY Register with the encryption key.
3. Set the IVEN bit.
4. Write the Initialization Vector to the AESIV Register.
5. Clear the IVEN bit; DMA and IRQ will not occur while this bit is set.
6. Write the plain text data to the AESDATA Register, or use DMA.
7. Set the START/BUSY bit in the AESSTAT Register, or use auto-start by setting AUTODIS=0 in [Step 1](#).
8. Poll the START/BUSY bit, or use an interrupt.
9. Read the cipher text from the AESDATA Register, or use DMA. The Initialization Vector is overwritten in preparation for the next 128-bit data block AES encryption operation, as shown in Figure 66.

► **Note:** The IVLD bit remains set even though the Initialization Vector has been overwritten. This bit remains set until either the AESEN bit is cleared or a byte is written to the AESIV Register. For subsequent OFB operations, if the key is unchanged, repeat steps 6 through 9 for additional blocks.

20.2.5. AES Cipher Block Chaining (CBC) Mode

The following sections describe AES CBC Mode.

20.2.5.1. AES CBC Mode Description

AES CBC Mode is selected by configuring MODE=10 in the AES Control Register. To encrypt in this mode, the AES accelerator uses the encryption key to operate on plain text, XORed with the previous cipher text, to generate cipher text. Because the previous cipher text is not available for the first operation, an Initialization Vector is utilized instead. A CBC encryption flow diagram is shown in Figure 68, and a CBC encryption example is provided in the CBC Mode Encryption Example section on the next page.

To decrypt CBC cipher text, perform decryption in ECB mode (MODE = 00). In AES ECB Mode, the AES accelerator uses the decryption key to operate on cipher text to generate an output block that can be further operated on by software to generate plain text. Typically, this operation involves XORing the output block with the initialization vector for the first output block and with the previous block cipher text for subsequent output blocks. An ECB Mode decryption flow diagram for CBC cipher text is shown in Figure 68.

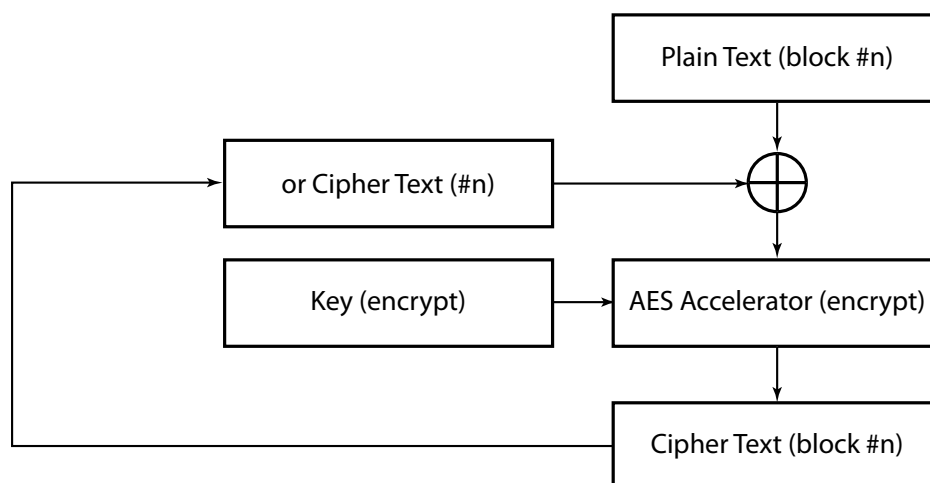

Figure 68. CBC Mode Encryption Flow Diagram

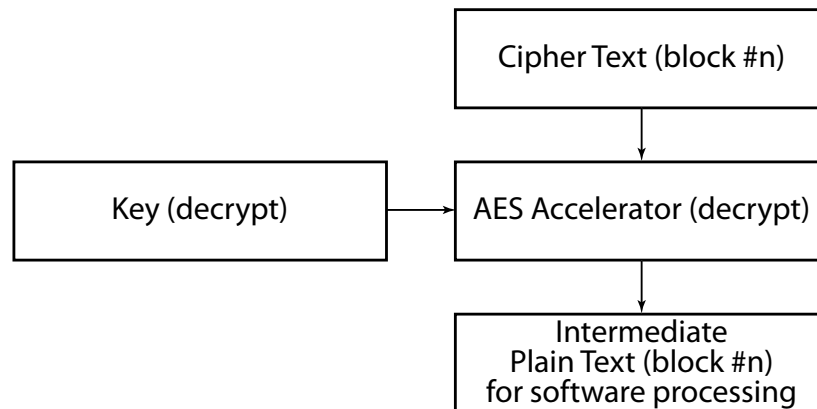

Figure 69. ECB Mode Decryption Flow Diagram for CBC Cipher Text

20.2.5.2. CBC Mode Encryption Example

The following sequence of operations is required to support CBC Mode encryption:

1. Write the AESCTRL Register as follows: AES_EN=1, MODE=10 (CBC), DECRYPT=0, AUTODIS=1.
2. Write the AESKEY Register with the encryption key.
3. Set the IVEN bit.
4. Write the Initialization Vector to the AESIV Register.
5. Clear the IVEN bit; DMA request or IRQ will not occur while this bit is set.
6. Write the plain text to the AESDATA Register, or use DMA.
7. Set the START/BUSY bit in the AESSTAT Register, or use auto-start by setting AUTODIS=0 in Step 1.
8. Poll the START/BUSY bit, or use an interrupt.
9. Read the cipher text from the AESDATA Register, or use DMA. The Initialization Vector is overwritten with cipher text in preparation for the next 128-bit data block AES encryption operation, as shown in Figure 68.

► **Note:** The IVLD bit remains set even though the Initialization Vector has been overwritten with cipher text. This bit remains set until either the AESEN bit is cleared or a byte is written to the AESIV Register. For subsequent CBC operations, if the key is unchanged, repeat steps 6 through 9 for additional blocks.

20.2.6. Decrypt Key Derivation

The Round 10 (R[10]) expanded encryption key can be used as the decryption key for decrypting data sent using the encryption key. This decryption key can be derived and made available for retrieval by performing a decrypt key derivation using MODE=11. For this operation, real or dummy plain text data can be used. When the operation is completed, the derived 16-byte R[10] decryption key can be read from the AESDATA Register and stored for use as a decryption key. The first key byte read is the most significant byte (associated with s(0,0) in [Figure 63](#) – see page 426).

Whenever MODE is written to 11, KEYLD is cleared. The decryption key will be derived only if the encryption key was loaded while MODE=11 which sets KEYLD=1. After a decrypt key derivation is completed, the decryption key is available to be read. When any other confidentiality mode is selected, the decryption key can no longer be read without again setting MODE=11, loading the encryption key, and starting/completing the decrypt key derivation.

The following example outlines a procedure for deriving and retrieving the decryption key.

1. Write the AESCTRL Register as follows: AES_EN=1, MODE=11 (KEYGEN), DECRYPT=0, AUTODIS=1.
2. Write the AESKEY Register with the encryption key.
3. Write real or dummy data to the AESDATA Register, or use DMA.
4. Set the START/BUSY bit in the AESSTAT Register, or use auto-start by setting AUTODIS=0 in Step 1.
5. Poll the START/BUSY bit, or use an interrupt.
6. Read the R[10] key from the AESDATA Register and store it.
7. Select another MODE.

20.3. AES Register Definitions

The AES accelerator is accessed through the registers listed in Table 228. The remainder of this chapter describes each of these registers.

Table 228. AES Register Summary

Name	Address	Description
AES Data Register (AESDATA)	FB8h	Accessed when IVEN=0.
AES Initialization Vector Register (AESIV)	FB8h	AES Initialization Vector Register; accessed when IVEN=1.
AES Key Register (AESKEY)	FB9h	AES Key Register.
AES Control Register (AESCTL)	FBAh	AES Control Register.
AES Status Register (AESSTAT)	FBBh	AES Status Register.

20.3.1. AES Data Register

The AES Data Register, shown in Table 229, addresses both the outgoing and incoming data to the AES accelerator.

Table 229. AES Data Register (AESDATA)

Bit	7	6	5	4	3	2	1	0
Field	DATA							
Reset	0	0	0	0	0	0	0	0
R/W	R/W	R/W	R/W	R/W	R/W	R/W	R/W	R/W
Address	FB8h, (IVEN=0)							

Bit	Description
[7:0] DATA	AES Data Access to this register is available when IVEN=0. After AESKEY and AESIV (if MODE=01 or 10) are loaded, this register must be written with 16 bytes to load the AES data for encryption/decryption. Successful loading is indicated by DATA LD=1. Writing this register while START/BUSY=1 causes the ERROR bit to be set, and the access is ignored.

20.3.2. Initialization Vector Register

The AES Initialization Vector Register, shown in Table 230, is only utilized for OFB and CBC modes.

Table 230. AES Initialization Vector Register (AESIV)

Bit	7	6	5	4	3	2	1	0
Field	IV							
Reset	0	0	0	0	0	0	0	0
R/W	W	W	W	W	W	W	W	W
Address	FB8h, (IVEN=1)							

Bit	Description
[7:0] IV	AES Initialization Vector Access to this register is available when IVEN=1. After loading AESKEY, this register must be written with 16 bytes to load the Initialization Vector. Successful loading is indicated by IVLD=1. Writing this register while START/BUSY=1 causes the ERROR bit to be set, and the access is ignored.

20.3.3. Key Register

The AES Key Register is shown in Table 231.

Table 231. AES Key Register (AESKEY)

Bit	7	6	5	4	3	2	1	0
Field	KEY							
Reset	0	0	0	0	0	0	0	0
R/W	W	W	W	W	W	W	W	W
Address	FB9h							

Bit	Description
[7:0] KEY	AES Key This register must be written with 16 bytes to load the AES key. Successful loading is indicated by KEYLD=1. The Key Register should be loaded prior to loading the Data Register. Writing this register during a conversion while START/BUSY=1 causes the ERROR bit to be set, and access is ignored. The AES key is cleared when the AES is disabled, and must be loaded after enabling the AES by setting the AESEN bit.

20.3.4. AES Control Register

The AES Control Register, shown in Table 232, configures the AES for operation.

Table 232. AES Control Register (AESCTL)

Bit	7	6	5	4	3	2	1	0
Field	AUTODIS	Reserved	IRQ	MODE		IVEN	DECRYPT	AESEN
Reset	0	0	0	0	0	0	0	0
R/W	R/W	R	R/W	R/W	R/W	R/W	R/W	R/W
Address	FBAh							

Bit	Description
[7] AUTODIS	Auto-Start Mode Disable 0: Enable Auto-Start Mode. 1: Disable Auto-Start Mode.
[6]	Reserved This bit is reserved and must be programmed to 0.
[5] IRQ	Interrupt Control 0: Interrupt on ERROR only. 1: Enables interrupt on DONE (BUSY=0) and ERROR.
[4:3] MODE	Confidentiality Mode Select 00: Electronic Codebook (ECB) Mode. 01: Output Feedback (OFB) Mode. 10: Cipher Block (CBC) Mode. 11: Decrypt Key Derivation.
[2] IVEN	Initialization Vector Enable 0: Disable writing to the Initialization Vector Register. Writing to the AES Data Register is enabled. 1: Enable writing to the Initialization Vector Register. Writing to the AES Data Register is disabled.
[1] DECRYPT	Decryption/Encryption Select 0: Encryption. 1: Decryption.
[0] AESEN	AES Enable 0: AES accelerator disabled and AESSTAT Register is reset. The Key and Initialization Vector must be loaded after AES enabled. 1: AES accelerator enabled for operation.

20.3.5. AES Status Register

The AES Status Register is shown in Table 233.

Table 233. AES Status Register (AESSTAT)

Bit	7	6	5	4	3	2	1	0
Field	START/ BUSY	Reserved			ERROR	IVLD	KEYLD	DATALD
Reset	0	0	0	0	0	0	0	0
R/W	R/W1*	R	R	R	R	R	R	R
Address	FBBh							

Note: *R/W1=Writing a 1 clears this bit.

Bit	Description
[7] START/ BUSY	AES Start/Busy Status 0: AES is idle or the requested encryption/decryption operation is complete. 1: Write 1 to start encryption/decryption, will remain 1 (Busy) till operation is complete and clears when finished.
[6:4]	Reserved These bits are reserved and must be programmed to 000.
[3] ERROR	ERROR Status 0: No error occurred during processing. 1: Error occurred during processing.
[2] IVLD	Initialization Vector Load Status 0: Initialization vector not fully loaded. 1: Initialization vector fully loaded.
[1] KEYLD	Key Load Status 0: Key not fully loaded. 1: Key fully loaded.
[0] DATALD	Data Load Status 0: Data not fully loaded. 1: Data fully loaded.

Chapter 21. Analog-to-Digital Converter

The F6482 Series MCUs include a seventeen-channel Successive Approximation Register Analog-to-Digital Converter (SAR ADC). This ADC converts an analog input signal to a 12-bit or 14-bit binary number, and includes the following additional features:

- 12-bit or 2-pass 14-bit resolution
- Twelve analog input sources multiplexed with general-purpose I/O ports
- Five internal analog input sources including: Op Amp A output, Op Amp B output, temperature sensor, bandgap, and $A_{VDD}/2$ fixed reference
- Four input modes: two single-ended modes, balanced differential mode, and unbalanced differential mode
- Conversion initiated by software or Event System input
- Channel scanning function
- Optional conversion averaging of 2, 4, 8, 16 samples
- Continuous conversion function that can be used with or without channel sequencing
- DMA support
- Fast conversion time, as low as $3\ \mu\text{s}$
- Programmable timing controls including ADC clock prescaler
- Window check function
- Interrupt on conversion complete or outside window
- Internal voltage reference selections of A_{VDD} or buffered VBIAS from the Reference System (2.5V, 2.0V, 1.5V, 1.25V)
- Buffered VBIAS internal reference voltage can be driven externally on V_{REF+}
- Ability to utilize external reference voltage
- In-situ calibration for all operating modes
- Auto-disable
- Two power settings

21.1. Architecture

The ADC can be operated with either single-ended inputs or differential inputs. The architecture, shown in Figure 70, consists of input multiplexers, sample-and-hold, an internal

voltage reference buffer, and a 12-bit SAR ADC. The ADC digitizes the signal on a selected channel and stores the digitized data in the ADC data registers. In environments with high electrical noise, an external RC filter must be added at the input pins to reduce high-frequency noise.

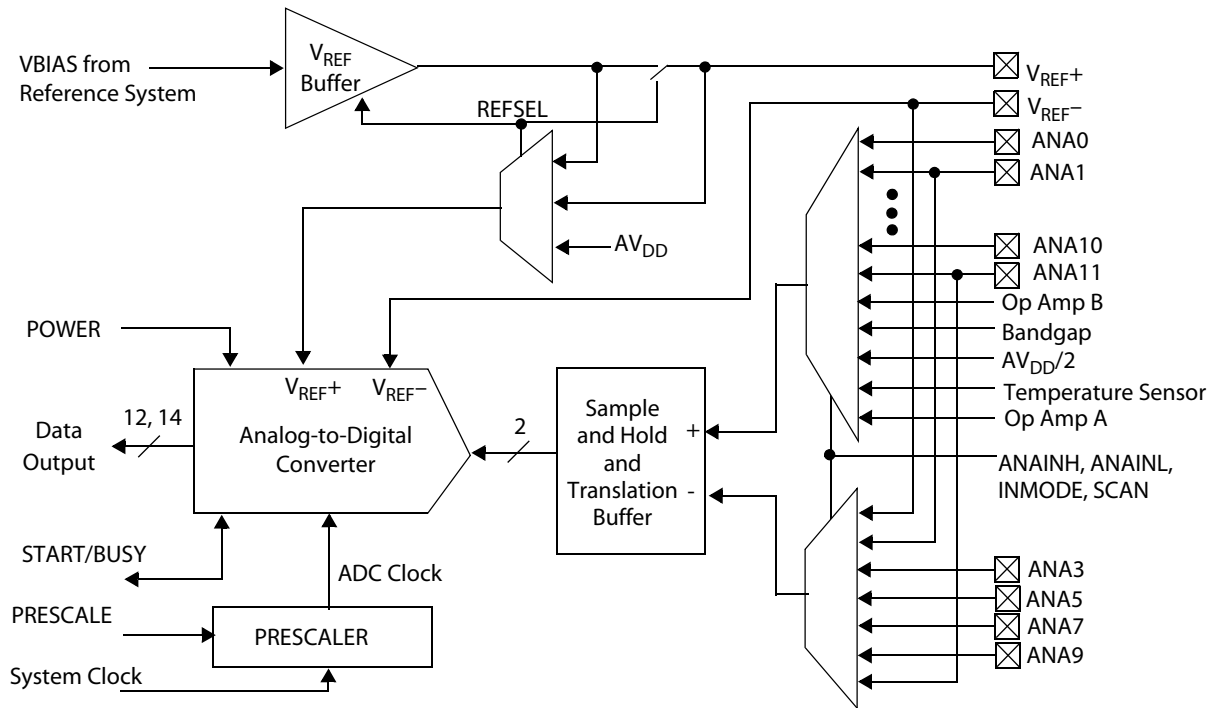

Figure 70. Analog-to-Digital Converter Block Diagram

21.2. Operation

The ADC converts the analog input, ANAx, to a digital representation. The ADC has selectable input modes, resolution, data format, conversion options, power options, window detection, and voltage reference options. The ADC can be serviced by the DMA.

Assuming zero gain and offset errors, any voltage outside the ADC input limits of V_{REF-} and V_{REF+} returns the minimum ADC output code or the maximum ADC output code, respectively.

21.2.1. Input Modes

Four input modes are available:

- Single-ended input
- Single-ended input with translation buffering
- Balanced differential inputs
- Unbalanced differential inputs with translation buffering

Single-ended input mode is selected by configuring $INMODE=00$. In this mode, one of 17 positive inputs can be selected using both $ANAINH$ and $ANAINL$, and are referenced to V_{REF-} . In this mode, V_{REF+} can range up to A_{VDD} .

Single-ended input mode with translation buffering is selected by configuring $INMODE=11$. In this mode, one of 17 positive inputs can be selected using both $ANAINH$ and $ANAINL$, and are referenced to V_{REF-} . The input signal is translated into a balanced differential signal using a translation buffer. This type of translation provides improved differential nonlinearity (DNL) at the expense of the current consumed by the translation buffer. In this mode, V_{REF+} can range up to $A_{VDD}-0.5V$.

Balanced differential input mode is selected by configuring $INMODE=01$. In this mode, one of 6 positive input pairs can be selected using $ANAINL$, and the inputs are treated as balanced, in that the positive input can be higher or lower than the negative input. In this mode, V_{REF+} can range up to A_{VDD} . Zilog recommends using balanced differential input mode 2-pass 14-bit conversion.

Unbalanced differential input mode with input translation is selected by configuring $INMODE=10$. In this mode, one of 6 positive input pairs can be selected using $ANAINL$, and the inputs are treated as unbalanced, in that the positive input must be higher than the negative input. The input signal is translated into a balanced differential signal using a translation buffer. This type of translation provides improved DNL at the expense of the current consumed by the translation buffer. In this mode, V_{REF+} can range up to $A_{VDD}-0.5V$.

The characteristics of these four input modes are summarized in Table 234.

Table 234. Input Mode Summary

INMODE	Input Topology	Translation Buffer Enabled	Recommended For 2-Pass 14-Bit Conversions	Maximum V_{REF+}
00	Single-Ended	No	No	A_{VDD}
01	Balanced Differential	No	Yes	A_{VDD}
10	Unbalanced Differential	Yes	No	$A_{VDD}-0.5V$
11	Single-Ended	Yes	No	$A_{VDD}-0.5V$

21.2.2. ADC Data Format

The ADC supports two data formats, unsigned and signed, selected by DFORMAT in the ADC Control 1 Register. When using signed data format, negative values are sign extended. Figures 71 through 73 show the relationship between data formats at 12-bit resolution, and ADC output data for the selectable input modes. The equation for calculating the ADC output data value is a function of input mode, resolution, and data format. The following equations can be used to calculate an ADC output data value for common combinations of input mode, resolution, and data format.

Single-ended input modes (INMODE=00, 11), unsigned (DFORMAT=0):

$$\text{ADC Output} = \text{FSR} \times ((\text{ANAx} - V_{\text{REF-}}) \div (V_{\text{REF+}} - V_{\text{REF-}}))$$

In the equation above, FSR (full-scale range) is 4095 for 12-bit conversions, and 16383 for 2-pass 14-bit conversions.

Balanced differential input mode (INMODE=01), signed (DFORMAT=1):

$$\text{ADC Output} = \text{FSR} \times ((\text{ANAx} - \text{ANAx}+1) \div (V_{\text{REF+}} - V_{\text{REF-}}))$$

In the equation above, 12-bit conversion FSR (full scale range) is -2048 for negative inputs and +2047 for positive inputs; 2-pass 14-bit conversion FSR is -8192 for negative inputs and +8191 for positive inputs.

Unbalanced differential input mode (INMODE=10), unsigned (DFORMAT=0):

$$\text{ADC Output} = \text{FSR} \times ((\text{ANAx} - \text{ANAx}+1) \div (V_{\text{REF+}} - V_{\text{REF-}}))$$

In the equation above, FSR (full-scale range) is 4095 for 12-bit conversions and 16383 for 2-pass 14-bit conversions.

Data is always right-justified with 14-bit width even when 12-bit resolution is selected. Conversion resolution can be configured to be 12-bit or 2-pass 14-bit, as defined by the RESOLUT bit in the ADC Control 1 Register. Note that bit 0 of the ACDCTL1 Register must be set for proper ADC operation.

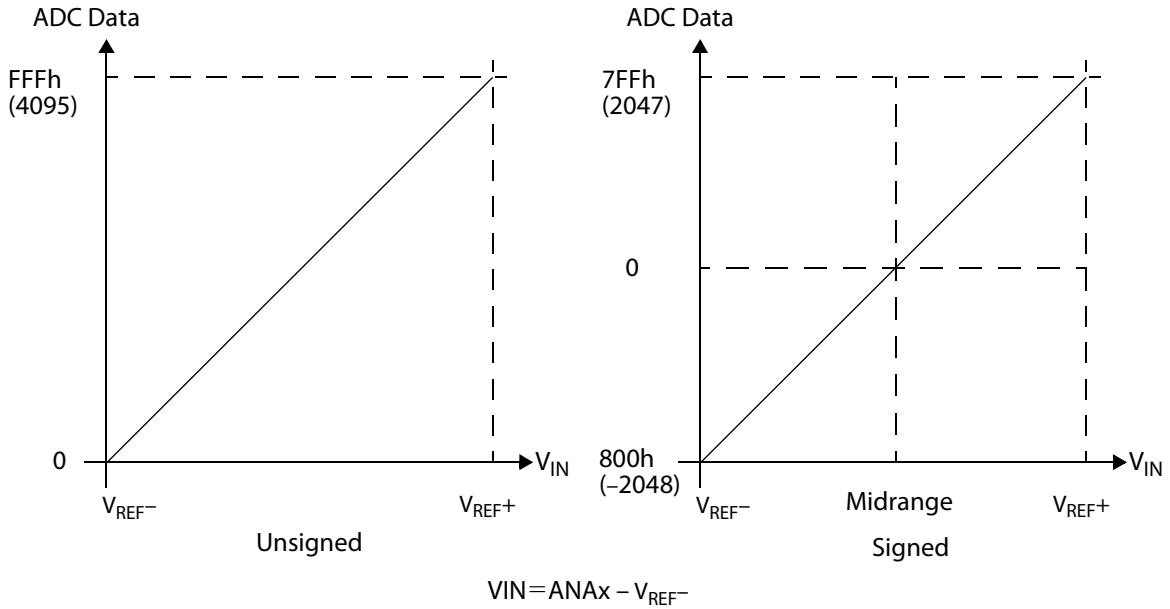

Figure 71. ADC Data (12-Bit) vs. Input Voltage for Single-Ended Input Modes

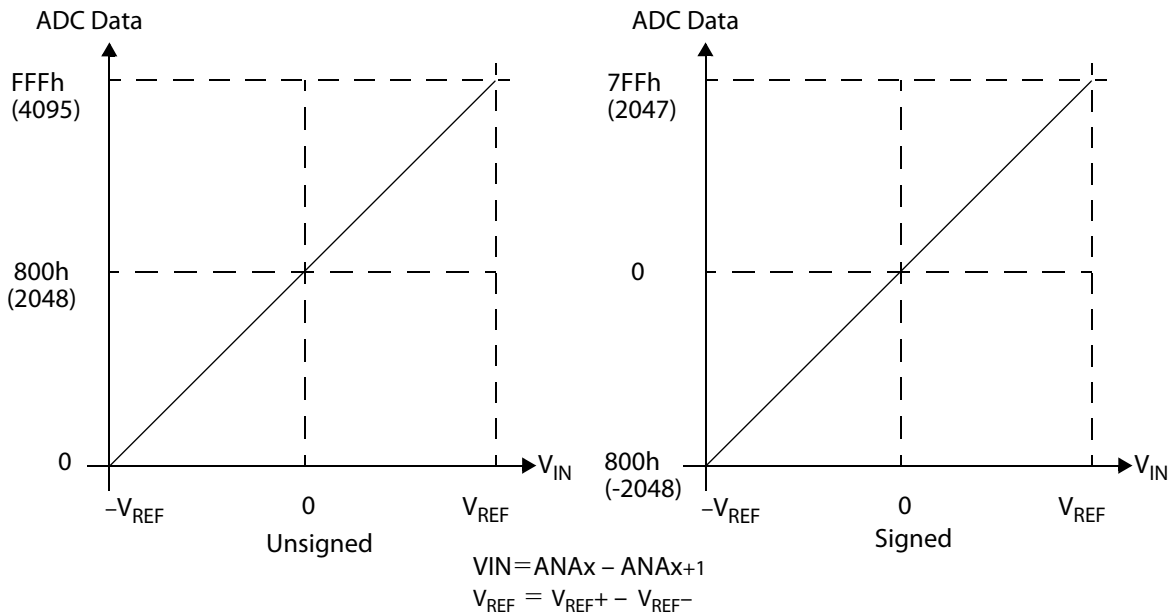

Figure 72. ADC Data (12-Bit) vs. Input Voltage for Balanced Differential Input Mode

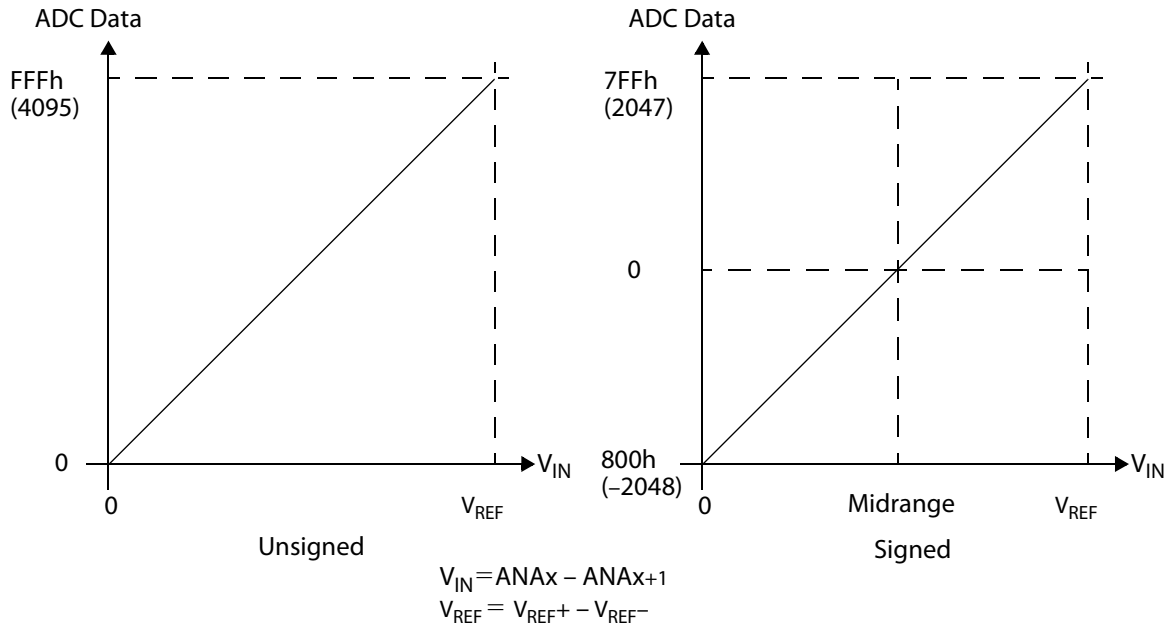

Figure 73. ADC Data (12-Bit) vs. Input Voltage for Unbalanced Differential Input Mode

21.2.3. Conversion Options

Five ADC conversion options are available, and are configured in the ADC Control 0 Register. These conversion options are independent from each other and can be selected in any combination. Furthermore, these conversion options can be enabled for any input mode. Each of these five options is described in the following subsections.

21.2.3.1. Single-Shot or Continuous Conversion

The ADC can be configured for single-shot or continuous conversion. When the CONTCONV bit is cleared, starting the ADC will produce a single result. When CONTCONV is set, starting the ADC will produce a continuous stream of results until CONTCONV is cleared. An interrupt can be generated for each conversion result. The data for each result can be moved by software or DMA.

21.2.3.2. Channel Scanning

The ADC can be configured to automatically scan multiple channels. If SCAN is cleared, channel scanning is not performed, and only the input (or input pair) defined in ANAINL is sampled for conversion.

If the SCAN bit is set, channel scanning is enabled, and the configuration of ANAINL and ANAINH determines which channels are scanned. If the bit corresponding to a particular channel is set, the channel will be included in the scan. Scanning commences with the LSB of ANAINL and completes with the MSB of ANAINH. ADC conversions are per-

formed only on the channels selected in ANAINL and ANAINH. Channels that are not selected are skipped.

The ADC configuration is identical for each channel scanned as defined in the ADC control registers. Timing parameters, ST and SST, should be configured for the requirements of the worst-case channel. If single-shot conversion is selected (CONTCONV=0), the ADC performs the scan sequence once. If continuous conversion is enabled, the ADC repeats the scan sequence in a continuous fashion.

An interrupt can be generated for each channel conversion result. The data for each channel result can be moved by software or DMA.

► **Note:** ADC scanning continues while the F6482 Series device is in Debug Mode, during which the CPU fetch unit stops. This activity can result in a loss of synchronization between user code and ADC scanned data.

21.2.3.3. Conversion Averaging

The ADC is capable of processing data from multiple individual conversions to form an averaged result. When averaging is enabled by setting the AVE bit, AVESAMP determines whether 2, 4, 8, or 16 samples are averaged to produce a result. An interrupt will be generated only when a final sample is obtained and processed into the average. If channel scanning is enabled, the averaged result is obtained sequentially for each channel being scanned.

21.2.3.4. Power Control

The ADC is capable of performing conversions at two different power settings, as selected by the POWER bit. When POWER=00, the ADC runs at higher current consumption, and can be clocked at up to 5 MHz. When POWER=10, the ADC runs at lower current consumption and can be clocked at up to 1 MHz. The lower power consumption setting can reduce overall current consumption for longer sampling times because the current consumption during sampling is reduced.

21.2.3.5. Resolution

When the RESOLUT bit is cleared, 12-bit conversions are performed. For applications that require even higher resolution, 2-pass 14-bit resolution conversions are performed when RESOLUT is set. These conversions involve somewhat longer timings than those described in the [2-Pass 14-Bit Resolution Timing](#) section on page 448. When performing 2-pass 14-bit conversion, Zilog recommends using the following input mode selection: INMODE=01.

21.2.4. Starting and Stopping Conversions

ADC activity is initiated by writing the START bits in the ADC Control 0 Register to perform a conversion (START=01), offset calibration (START=10), or gain calibration

(START=11). When SCAN=1, starting a conversion by writing START=01 initiates channel scanning. Additionally, the Event System can trigger a new conversion and cause START to be set to 01. When a calibration is initiated, SCAN and CONTCONV are ignored.

When a conversion or calibration completes, START is cleared to 00 automatically by hardware. To avoid disrupting a conversion already in progress, START can be read to indicate ADC operation status (busy or available). If the result from a previous ADC operation is not read before the result from a subsequent ADC operation is complete, the previous result is overwritten.

The recommended procedure to stop continuous conversions is to first clear SCAN, if set, and then to clear CONTCONV together with AVE, if set. The currently-active conversion will continue to completion, at which time START is cleared to 00.

21.2.5. Voltage References

The ADC positive voltage reference is selected with REFSEL. The ADC negative reference should always be configured as V_{REF-} using the GPIO Alternate Function Selection described in the [General-Purpose Input/Output](#) chapter on page 55. ADC positive voltage reference selection options are:

- A_{VDD} (REFSEL=00)
- External voltage reference on V_{REF+} (REFSEL=01)
- Internal voltage reference buffer which buffers VBIAS from the Reference System (REFSEL=10) via an internal connection
- Internal voltage reference buffer connected to V_{REF+} which buffers VBIAS from the Reference System (REFSEL=11)

VBIAS in the Reference System offers four possible level settings that are selected with REFLVL, namely: 1.25V, 1.5V, 2.0V, and 2.5V. Care should be exercised to ensure that A_{VDD} is always at least 0.5V greater than the selected VBIAS level. Wake-up of the internal voltage reference buffer can be performed automatically or manually.

Automatic Wake-Up. If the ADC bits are cleared to 00 in the PWRCTL1 Register, then when ADC activity is triggered, the ADC and ADC internal voltage reference buffer will wake up for the duration of the ADC wake-up period, T_{WAKE_ADC} , prior to the ADC conversion being performed (see the [Electrical Characteristics](#) chapter on page 601). When the conversion is completed, the ADC auto-disable feature will automatically disable the ADC and the ADC internal voltage reference buffer when no further conversions are scheduled. If performing multiple sequential conversions due to averaging, scanning or continuous conversion, the wake-up time is incurred only prior to the first conversion.

Manual Wake-Up. When the ADC bits are set to 11 in the PWRCTL1 Register, the ADC is continuously enabled and the ADC internal voltage reference buffer is continuously

enabled if it is selected as the ADC positive voltage reference. The ADC bits are typically set when the ADC internal voltage reference buffer is connected to the V_{REF+} pin (REFSEL=11 in the ADCCTL2 Register).

When using the internal voltage reference buffer connected to V_{REF+} (REFSEL=11), an external bypass capacitor is required, as defined in the [Electrical Characteristics](#) chapter on page 601.

► **Note:** If the DAC is also configured to drive V_{REF+} , the DAC voltage reference buffer selection is used.

21.2.6. ADC Timing

System Clock can be prescaled to form the ADC clock with the divisor defined by the PRESCALE bit. ADC timing is a function of resolution, as described in the following sections. When the ADC exits the idle state to perform a conversion, a wake-up time, T_{WAKE_ADC} , may be incurred, as defined in [ADC Wake-up, Sampling, and Settling](#) on page 449 and the [Electrical Characteristics](#) chapter on page 601.

21.2.6.1. 12-Bit Resolution Timing

Each 12-bit resolution (RESOLUT=0) ADC measurement consists of 3 phases:

1. Input sampling time, as defined by the ST bit, is a function of source impedance and the desired accuracy, as discussed later in this section. The minimum input sampling period is 200ns, with the input translation buffer disabled (INMODE=00, 01), and 800ns with the input translation buffer enabled (INMODE=10, 11).
2. Sample-and-hold amplifier settling time, as defined by the SST bit, is a minimum of 200ns, with the input translation buffer disabled (INMODE=00, 01), and 800ns with the input translation buffer enabled (INMODE=10, 11).
3. Sample conversion time is 13 ADC clock cycles with a maximum frequency of 5.0MHz.

Figure 74 shows the timing of a 12-bit ADC conversion.

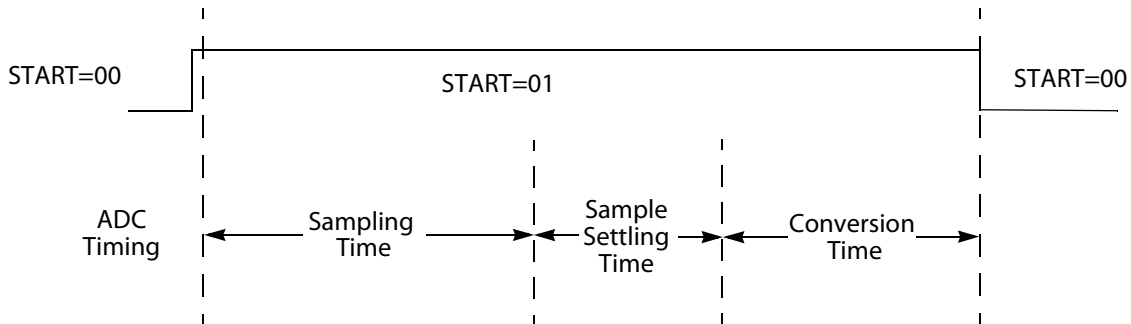

Figure 74. ADC Timing Diagram for 12-Bit Resolution

21.2.6.2. 2-Pass 14-Bit Resolution Timing

Each 2-pass 14-bit resolution (RESOLUT=1) ADC measurement consists of up to 5 phases:

1. Input sampling time as defined by the ST bit, is a function of source impedance and the desired accuracy, as discussed later in this section. The minimum input sampling period is 200ns for balanced differential input mode (INMODE=01), and 800ns with the input translation buffer enabled (INMODE=10, 11). For balanced differential input mode, ST occurs twice during a conversion.
2. Sample-and-hold amplifier settling time, as defined by the SST bit, is a minimum of 200ns for balanced differential mode (INMODE=01), and 1000ns with the input translation buffer enabled (INMODE=10, 11). SST occurs twice for all input modes.
3. Sample conversion time is 15 ADC clock cycles with a maximum frequency of 4.0MHz. Sample conversion occurs twice for all conversion modes.

Figure 75 shows the timing of a 2-pass 14-bit ADC conversion with (INMODE=10, 11), and Figure 76 shows the timing of a 2-pass 14-bit ADC conversion with (INMODE=01).

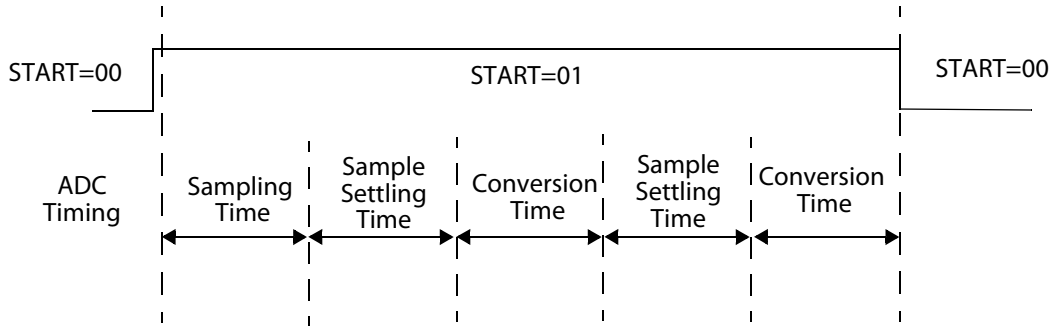

Figure 75. ADC Timing Diagram for 2-Pass 14-Bit Resolution with INMODE=10, 11

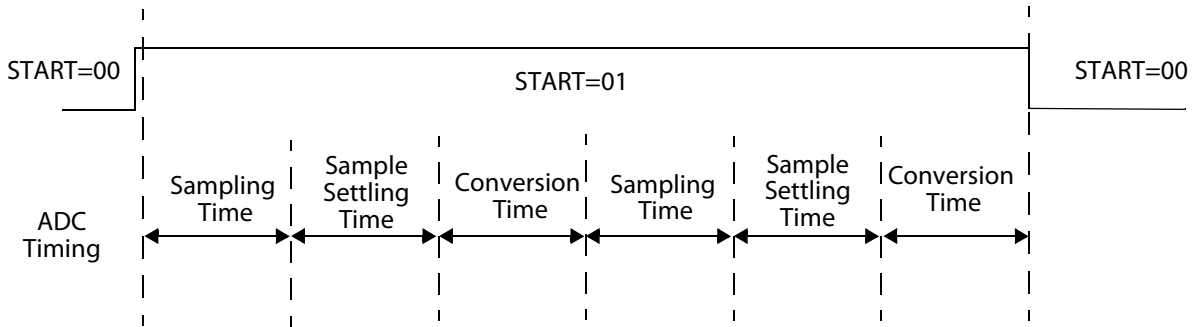

Figure 76. ADC Timing Diagram for 2-Pass 14-Bit Resolution with INMODE=01

21.2.6.3. ADC Wake-up, Sampling, and Settling

As the ADC is designed for low-power applications, the ADC core can be configured to auto-disable when no further conversions are scheduled by clearing ADC to 00 in the PWRCTL1 Register. When triggered to start a new conversion while the ADC is idle and ADC=00, the ADC wake-up period, T_{WAKE_ADC} , is automatically inserted prior to sampling (see the [Electrical Characteristics](#) chapter on page 601). If selected as VREF+, the internal voltage reference buffer will also automatically wake-up prior to sampling. When the conversion is completed and ADC = 00, the ADC's auto-disable feature will automatically disable the ADC when no further conversions are scheduled.

If performing multiple sequential conversions due to averaging, scanning or continuous conversion, it is recommended to turn off the ADC auto-disable function by setting ADC to 11 in the PWRCTL1 Register. When ADC is set to 11, the ADC is continuously enabled and T_{WAKE_ADC} is not incurred when the ADC is triggered to perform a conversion. After setting ADC=11, wait T_{WAKE_ADC} prior to triggering an ADC conversion.

The sample period is a function of source impedance and the desired accuracy. While sampling is occurring, the ADC input impedance changes from high impedance to a series $2\text{K}\Omega$ (max) resistance and a shunt 5pF (max) between the signal source and the ADC input, as shown in Figure 77. Sufficient sampling time should be allotted to charge the capacitance to the desired accuracy. The following equation describes the minimum sampling time required to charge the capacitor to 1/2 LSB for resolution, n:

$$ST > (R_s + R_i) \times \ln(2^{n+1}) \times C_i + ST_{\min}$$

In this equation, ST is the sampling time, R_s is the source resistance, R_i is the ADC series input resistance, C_i is the ADC shunt input capacitance, n is the resolution and ST_{\min} is the minimum sampling time specified.

For example, to achieve 12-bit resolution with $\text{INMODE}=00$, $R_s=10\text{K}\Omega$, and maximum internal input resistance and capacitance, consider the following equation:

$$ST > (10\text{K}\Omega + 2\text{K}\Omega) \times \ln(2^{12+1}) \times 5\text{pF} + 200\text{ns}$$

In this equation, $ST > 0.74\mu\text{s}$.

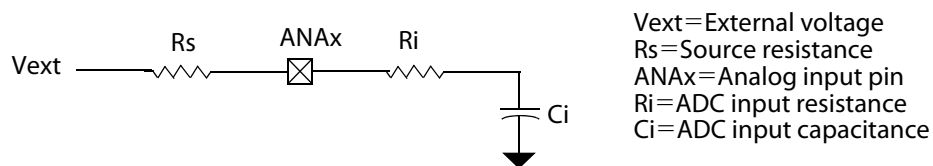

Figure 77. ADC Input Equivalent Circuit

21.2.7. Window Detection

Window detection is available using the window upper threshold registers, ADCUWINH and ADCUWINL , and the window lower threshold registers, ADCLWINH and ADCLWINL . An interrupt is generated if the ADC result is outside the window, meaning that the result is either greater than the value in the window upper threshold registers, or lower than the value in the window lower threshold registers. If only below-threshold detection is desired, configure the upper threshold registers to be the maximum conversion value (all 1s). If only above-upper-threshold detection is desired, configure the lower threshold registers to be the minimum conversion value (all 0s).

The window threshold registers contain unsigned data. When using the signed ADC output data format ($\text{DFORMAT}=1$), the ADC maintains and uses an unsigned value of the ADC data output for comparison against the window threshold registers. Window comparison occurs only upon a new ADC result; changes to a window threshold register's contents will not result in a comparison against residual ADC output data.

21.2.8. ADC Interrupts and DMA

The ADC can generate an interrupt request upon each new ADC result for any completed conversion or calibration (START= 01, 10, 11). The ADC can also generate an interrupt if the conversion result is outside the range defined by the window threshold registers (ADCUWINH, ADCUWINL, ADCLINH, ADCLWINL). Use the IRQ bit in the ADC Control 0 Register to select whether interrupts are generated due to only exceeding the window thresholds or due to both exceeding the window thresholds and end of convert. An interrupt request that is pending when the ADC is disabled or idle (ready) is not automatically cleared.

The ADC will assert a DMA request upon each new ADC result, and will deassert a DMA request whenever the ADCD_L Register (DMACTL=0) or ADCD_H Register (DMACTL=1) is read by the DMA or software. When DMACTL=0, the typical goal is to transfer both data bytes, and the DMA is configured to have fixed word address control for the DMA source address; the source address is configured to be the ADCD_H Register address. When DMACTL=1, the typical goal is to transfer only the most significant data byte, and the DMA is configured to have fixed address control for the DMA source address; the source address is configured to be the ADCD_H Register address.

If starting a new ADC conversion and DMA transfer sequence, reading the ADC_L Register (DMACTL=0) or the ADC_H Register (DMACTL=1) prior to enabling DMA and starting conversion ensures that any residual ADC DMA request from prior ADC activity is deasserted. A DMA request is not asserted upon the completion of an offset or gain calibration.

21.2.9. Calibration and Compensation

Both gain and offset calibration can be performed in situ to achieve even higher accuracy than specified in the [Electrical Characteristics](#) chapter on page 601. These calibration operations are performed using the current ADC configuration, as defined by the INMODE, PRESCALE, ST, and SST bits. After these parameters are reconfigured, initiating calibration prior to performing conversions can optimize results. Only initiate calibration when continuous conversion is not selected (i.e., CONTCONV = 0).

Offset calibration is performed when the START bits are written to 10. Prior to initiating offset calibration, 14-bit resolution must be selected by setting RESOLUT = 1. The offset result can be used for both 12-bit and 14-bit resolution conversions. The calibration is complete when START is cleared to 00.

The value in the OFFSET field is automatically applied to compensate subsequent conversions by hardware. Offset correction by hardware is effective for signed mode (DFORMAT = 1) only. For unsigned mode (DFORMAT = 0), software should store the value of OFFSET, clear OFFSET to 00h, and perform any desired offset compensation.

As each ADC configuration can exhibit a unique offset calibration, the offset calibration value for each ADC configuration of interest can be stored. Stored offset values can be used to compensate both 12-bit and 14-bit resolution conversions as shown in Table 235.

Table 235. Compensating ADC results for ADC offset

ADC offset calibration RESOLUT value	ADC conversion RESOLUT value	ADC offset compensated result formula using stored OFFSET value
RESOLUT=x	RESOLUT=0 (12-bit)	{ADCD_H, ADCD_L} - stored_ADCOFF/4
RESOLUT=x	RESOLUT=1 (14-bit)	{ADCD_H, ADCD_L} - stored_ADCOFF

Gain calibration is performed when the START bits are written to 11. The calibration is complete when START is cleared to 00. To utilize the gain factor, first read it from the ADCD_H and ADCD_L registers following a gain calibration and store it. The gain factor can then be applied to a raw ADC result or to an offset compensated ADC result by software to produce a gain-compensated result, as follows:

$$\text{ADC gain-compensated result} = \text{ADC result} \times ((\text{full scale range} \times 0.75) \div (\text{stored_gain_factor}))$$

21.3. ADC Control Register Definitions

The registers that control analog-to-digital conversion functions are defined in this section.

21.3.1. ADC Control 0 Register

The ADC Control 0 Register, shown in Table 236, initiates the A/D conversion, provides ADC status information and contains conversion control options.

Table 236. ADC Control 0 Register (ADCCTL0)

Bits	7	6	5	4	3	2	1	0
Field	START		DMACTL	IRQ	CONTCONV	AVE	AVESAMP	
Reset	0	0	0	0	0	0	0	0
R/W	R/W	R/W	R	R/W	R/W	R/W	R/W	R/W
Address	F70h							

Bit	Description
[7:6] START	<p>ADC Start/Busy</p> <p>00: Reading 00 indicates the ADC is available to begin a conversion or calibration.</p> <p>01: Writing 01 starts a conversion. Reading 01 indicates that a conversion is currently in progress.</p> <p>10: Writing 10 starts an offset calibration. Reading 10 indicates that an offset calibration is currently in progress. Set RESOLUT = 1 prior to initiating an offset calibration.</p> <p>11: Writing 11 starts a gain calibration. Reading 11 indicates that a gain calibration is currently in progress.</p>
[5] DMACTL	<p>DMA Request Control</p> <p>0: Reading the ADCD_L Register clears a DMA request. This setting is typically used when a DMA accesses both ADC data bytes with DMA fixed word addressing.</p> <p>1: Reading the ADCD_H Register clears a DMA request. This setting is typically used when a DMA accesses only the most significant ADC data byte with DMA fixed addressing.</p>
[4] IRQ	<p>Interrupt Control</p> <p>0: Outside window.</p> <p>1: Both end of convert and outside window.</p>
[3] CONTCONV	<p>Continuous Conversion Enable</p> <p>0: Single-shot conversion.</p> <p>1: Continuous conversion.</p>
[2] AVE	<p>Averaging Enable</p> <p>0: Averaging of ADC samples is disabled.</p> <p>1: Averaging of ADC samples is enabled. The number of samples to convert to form each ADC result are determined by AVESAMP.</p>
[1:0] AVESAMP	<p>Averaging Samples</p> <p>If AVE = 1, ADC samples are averaged to form an ADC result.</p> <p>00: 2 samples are converted to form each ADC result.</p> <p>01: 4 samples are converted to form each ADC result.</p> <p>10: 8 samples are converted to form each ADC result.</p> <p>11: 16 samples are converted to form each ADC result.</p>

21.3.2. ADC Control 1 Register

The ADC Control 1 Register, shown in Table 237, contains control for the ADC input mode and other ADC features. Note that bit 0 of this register must be set to 1 for proper ADC operation.

Table 237. ADC Control 1 Register (ADCCTL1)

Bits	7	6	5	4	3	2	1	0
Field	POWER		SCAN	INMODE		DFORMAT	RESOLUT	Reserved
Reset	0	0	0	0	0	0	0	0
R/W	R/W	R/W	R/W	R/W	R/W	R/W	R/W	R/W
Address	F71h							

Bit	Description
[7:6] POWER	Power Control 00: Higher maximum conversion speed, higher power consumption. 01: Reserved. 10: Lower maximum conversion speed, lower power consumption. 11: Reserved.
[5] SCAN	Channel Scanning Enable The channels to be scanned are determined by ANAINH and ANAINL. 0: Channel scanning is disabled. 1: Channel scanning is enabled.
[4:3] INMODE	Input Mode 00: Single-ended. 01: Balanced differential. 10: Unbalanced differential with translation buffer. 11: Single-ended with translation buffer.
[2] DFORMAT	Data Format 0: Data is unsigned (binary). 1: Data is signed (two's complement). Negative values are sign-extended.
[1] RESOLUT	ADC Conversion Resolution 0: 12-bit resolution. 1: 2-pass 14-bit resolution.
[0]	Reserved This bit is reserved and must be programmed to 1 which changes the reset value.

21.3.3. ADC Control 2 Register

The ADC Control 2 Register, shown in Table 238, contains control for the ADC prescaler, reference selection and power consumption.

Table 238. ADC Control 2 Register (ADCCTL2)

Bits	7	6	5	4	3	2	1	0
Field	REFSEL		REFLVL		PRESCALE			
Reset	0	0	0	0	0	0	0	0
R/W	R/W	R/W	R/W	R/W	R/W	R/W	R/W	R/W
Address	F72h							

Bit	Description
[7:6] REFSEL	<p>ADC Positive Voltage Reference Select</p> <p>If REFSEL = 11 and the DAC is also configured to drive V_{REF+}, the DAC voltage reference buffer selection is used.</p> <p>00: Internal connection to AV_{DD}. 01: V_{REF+} pin driven by an external source. 10: Buffered VBIAS from the Reference System using an internal connection. 11: Buffered VBIAS from the Reference System drives the V_{REF+} pin.</p>
[5:4] REFLVL	<p>VBIAS Level Select</p> <p>00: 1.25V. 01: 1.5V. 10: 2.0V. 11: 2.5V.</p>
[3:0] PRESCALE	<p>ADC Clock Prescale Divider</p> <p>0000: ADC Clock is System Clock divided by 1. 0001: ADC Clock is System Clock divided by 2. 0010: ADC Clock is System Clock divided by 3. 0011: ADC Clock is System Clock divided by 4. 0100: ADC Clock is System Clock divided by 5. 0101: ADC Clock is System Clock divided by 6. 0110: ADC Clock is System Clock divided by 7. 0111: ADC Clock is System Clock divided by 8. 1000: ADC Clock is System Clock divided by 9. 1001: ADC Clock is System Clock divided by 10. 1010: ADC Clock is System Clock divided by 11. 1011: ADC Clock is System Clock divided by 12. 1100: ADC Clock is System Clock divided by 13. 1101: ADC Clock is System Clock divided by 14. 1110: ADC Clock is System Clock divided by 15. 1111: ADC Clock is System Clock divided by 16.</p>

21.3.4. ADC Input Select High Register

The ADC Input Select High Register, shown in Table 239, selects the ADC input(s) for conversion. This register is used only when SCAN is set and the ADC inputs to be scanned are defined both in ADCINSH and ADCINSL.

Table 239. ADC Input Select High Register (ADCINSH)

Bits	7	6	5	4	3	2	1	0
Field	Reserved	ANAINH						
Reset	0	0	0	0	0	0	0	0
R/W	R	R/W	R/W	R/W	R/W	R/W	R/W	R/W
Address	F73h							

Bit	Description
[7]	Reserved This bit is reserved and must be programmed to 0.
[6:0] ANAINH	Analog Input Selection High ADC Input Selection is a function of SCAN and INMODE. SCAN=0, INMODE = xx All bits are reserved.
[6:0] ANAINH (cont'd.)	SCAN=1, INMODE=00, 11 xxxxxx1: ANA8 input is selected for ADC scanning. Additional inputs may be selected. xxxxx1x: ANA9 input is selected for ADC scanning. Additional inputs may be selected. xxxx1xx: ANA10 input is selected for ADC scanning. Additional inputs may be selected. xxx1xxx: ANA11 input is selected for ADC scanning. Additional inputs may be selected. xx1xxxx: Op Amp A output is selected for ADC scanning. Additional inputs may be selected. x1xxxxx: Op Amp B output is selected for ADC scanning. Additional inputs may be selected. 1xxxxxx: Temperature Sensor is selected for ADC scanning. Additional inputs may be selected. SCAN=1, INMODE=01, 10 All bits are reserved.

21.3.5. ADC Input Select Low Register

The ADC Input Select Low Register, shown in Table 240, selects the ADC input(s) for conversion. If SCAN is set, ADCINSH and ADCINSL are both used to define the ADC inputs to be scanned, otherwise, only ADCINSL is used to select the ADC input(s).

Table 240. ADC Input Select Low Register (ADCINSL)

Bits	7	6	5	4	3	2	1	0
Field	ANAINL							
Reset	0	0	0	0	0	0	0	0
R/W	R/W	R/W	R/W	R/W	R/W	R/W	R/W	R/W
Address	F74h							

Bit	Description
[7:0] ANAINL	<p>Analog Input Selection Low ADC Input Selection is a function of SCAN and INMODE.</p> <hr/> <p>SCAN=0, INMODE=00, 11</p> <p>00000000: ANA0 input is selected for analog-to-digital conversion. 00000001: ANA1 input is selected for analog-to-digital conversion. 00000010: ANA2 input is selected for analog-to-digital conversion. 00000011: ANA3 input is selected for analog-to-digital conversion. 00000100: ANA4 input is selected for analog-to-digital conversion. 00000101: ANA5 input is selected for analog-to-digital conversion. 00000110: ANA6 input is selected for analog-to-digital conversion. 00000111: ANA7 input is selected for analog-to-digital conversion. 00001000: ANA8 input is selected for analog-to-digital conversion. 00001001: ANA9 input is selected for analog-to-digital conversion.</p>

Bit	Description (Continued)
[7:0]	00001010: ANA10 input is selected for analog-to-digital conversion.
ANAINL	00001011: ANA11 input is selected for analog-to-digital conversion.
(cont'd.)	00001100: Op Amp A output is selected for analog-to-digital conversion.
	00001101: Op Amp B output is selected for analog-to-digital conversion.
	00001110: Temperature Sensor is selected for analog-to-digital conversion.
	00001111: AVDD/2 Fixed Reference is selected for analog-to-digital conversion.
	00010000: Bandgap reference is selected for analog-to-digital conversion.
	All other bits are reserved.
SCAN=0, INMODE=01, 10	
0000000x:	ANA0 input is selected as the positive input for analog-to-digital conversion. ANA1 input is selected as the negative input for analog-to-digital conversion.
0000001x:	ANA2 input is selected as the positive input for analog-to-digital conversion. ANA3 input is selected as the negative input for analog-to-digital conversion.
0000010x:	ANA4 input is selected as the positive input for analog-to-digital conversion. ANA5 input is selected as the negative input for analog-to-digital conversion.
0000011x:	ANA6 input is selected as the positive input for analog-to-digital conversion. ANA7 input is selected as the negative input for analog-to-digital conversion.
0000100x:	ANA8 input is selected as the positive input for analog-to-digital conversion. ANA9 input is selected as the negative input for analog-to-digital conversion.
0000101x:	ANA10 input is selected as the positive input for analog-to-digital conversion. ANA11 input is selected as the negative input for analog-to-digital conversion.
	All other bits are reserved.
SCAN=1, INMODE=00, 11	
xxxxxxx1:	ANA0 input is selected for ADC scanning. Additional inputs may be selected.
xxxxxx1x:	ANA1 input is selected for ADC scanning. Additional inputs may be selected.
xxxxx1xx:	ANA2 input is selected for ADC scanning. Additional inputs may be selected.
xxxx1xxx:	ANA3 input is selected for ADC scanning. Additional inputs may be selected.
xxx1xxxx:	ANA4 input is selected for ADC scanning. Additional inputs may be selected.
xx1xxxxx:	ANA5 input is selected for ADC scanning. Additional inputs may be selected.
x1xxxxxx:	ANA6 input is selected for ADC scanning. Additional inputs may be selected.
1xxxxxxx:	ANA7 input is selected for ADC scanning. Additional inputs may be selected.
SCAN=1, INMODE=01, 10	
00xxxxx1:	ANA0 and ANA1 are selected as a differential input pair for ADC scanning. ANA0 input is selected as the positive input for analog-to-digital conversion. ANA1 input is selected as the negative input for analog-to-digital conversion.
00xxxx1x:	ANA2 and ANA3 are selected as a differential input pair for ADC scanning. ANA2 input is selected as the positive input for analog-to-digital conversion. ANA3 input is selected as the negative input for analog-to-digital conversion.
00xxx1xx:	ANA4 and ANA5 are selected as a differential input pair for ADC scanning. ANA4 input is selected as the positive input for analog-to-digital conversion. ANA5 input is selected as the negative input for analog-to-digital conversion.
00xx1xxx:	ANA6 and ANA7 are selected as a differential input pair for ADC scanning. ANA6 input is selected as the positive input for analog-to-digital conversion. ANA7 input is selected as the negative input for analog-to-digital conversion.

Bit	Description (Continued)
[7:0]	SCAN=1, INMODE=01, 10 (continued)
ANAINL (cont'd.)	00x1xxxx: ANA8 and ANA9 are selected as a differential input pair for ADC scanning. ANA8 input is selected as the positive input for analog-to-digital conversion. ANA9 input is selected as the negative input for analog-to-digital conversion.
	001xxxxx: ANA10 and ANA11 are selected as a differential input pair for ADC scanning. ANA10 input is selected as the positive input for analog-to-digital conversion. ANA11 input is selected as the negative input for analog-to-digital conversion.
	All other bits are reserved.

21.3.6. ADC Offset Calibration Register

The ADC Offset Calibration Register, shown in Table 241, contains the ADC offset calibration value.

Table 241. ADC Offset Calibration Register (ADCOFF)

Bits	7	6	5	4	3	2	1	0
Field	OFFSET							
Reset	00h							
R/W	R/W							
Address	F75h							

Bit	Description
OFFSET	ADC Offset Calibration Value The ADC Offset Calibration Value is a function of RESOLUT. OFFSET is in two's complement format and is applied by the ADC to compensate conversions (START=01) for offset errors. The ADC places the result from offset calibration (START=10) in OFFSET. The value can be read by software and re-written to OFFSET at a later time, for example, when using multiple input modes, each with a unique offset calibration value. Offset correction by hardware is effective for signed mode (DFORMAT = 1) only. For unsigned mode (DFORMAT = 0), software should store the value of OFFSET, clear OFFSET to 00h, and perform any desired offset compensation.
RESOLUT = 0 (12-bit)	
[7:2]	00–3F: 2's complement offset value.
[1:0]	0–1: Reserved.
RESOLUT = 1 (14-bit)	
[7:0]	00–FF: 2's complement offset value.

21.3.7. ADC Data High Register

The ADC Data High Register, shown in Table 242, contains the MSBs of the ADC result. Access to the ADC Data High Register is read-only. Reading the ADC Data High Register latches data in the ADC Low Register.

Table 242. ADC Data High Register (ADCD_H)

Bits	7	6	5	4	3	2	1	0
Field	ADCDH							
Reset	00h							
R/W	R							
Address	F76h							

Bit	Description
ADCDH	ADC Data High
[7:6]	Reserved: these bits must be programmed to 00.
[5:0]	00–3F: The 6 MSBs of the last conversion result are held in the 6 LSBs of this data register until the next ADC conversion has completed.

21.3.8. ADC Data Low Register

The ADC Data Low Register, shown in Table 243, contains the LSBs of the ADC result. Access to the ADC Data Low Register is read-only. Reading the ADC Data High Register latches data in the ADC Low Register.

Table 243. ADC Data Low Register (ADCD_L)

Bits	7	6	5	4	3	2	1	0
Field	ADCDL							
Reset	00h							
R/W	R							
Address	F77h							

Bit	Description
ADCDL	ADC Data Low ADC Data Low is a function of RESOLUT.
RESOLUT = 0 (12-bit)	
[7:2]	00–3F: The 6 LSBs of the last conversion result are latched into this data register whenever the ADC Data High Byte register is read.
[1:0]	0–1: Reserved.



Bit	Description (Continued)
RESOLUT = 1 (14-bit)	
[7:0]	00–FF: The 8 LSBs of the last conversion result are latched into this data register whenever the ADC Data High Byte register is read.

21.3.9. Sample Time Register

The Sample Time Register, shown in Table 244, is used to program the length of the sampling time and sample settling time after a conversion begins by setting the START=01 in the ADC Control 0 Register or is initiated by the Event System. The number of ADC clock cycles required for sample time varies from system to system, depending on the impedance of the external source and the ADC clock period used. The system designer should program this register to contain the number of ADC clocks required to meet accuracy requirements as described in the [ADC Timing](#) section on page 447.

Table 244. Sample Time (ADCST)

Bits	7	6	5	4	3	2	1	0
Field	ST				SST			
Reset	0	0	0	0	0	0	0	0
R/W	R/W	R/W	R/W	R/W	R/W	R/W	R/W	R/W
Address	F78h							

Bit	Description
[7:4]	Sampling Time
ST	0000: 2 ADC clocks. 0001: 2 ADC clocks. 0010: 4 ADC clocks. 0011: 8 ADC clocks. 0100: 16 ADC clocks. 0101: 32 ADC clocks. 0110: 64 ADC clocks. 0111: 96 ADC clocks. 1000: 128 ADC clocks. 1001: 192 ADC clocks. 1010: 256 ADC clocks. 1011: 320 ADC clocks. 1100: 384 ADC clocks. 1101: 512 ADC clocks. 1110: 768 ADC clocks. 1111: 1024 ADC clocks.

Bit	Description (Continued)
[3:0] SST	<p>Sample Settling Time SST is dependent upon the value of INMODE.</p> <p>INMODE=00, 01 xxxx: 1 ADC clock.</p> <p>INMODE=10 or 11 0000: 1 ADC clock. 0001: 2 ADC clocks. 0010: 3 ADC clocks. 0011: 4 ADC clocks. 0100: 5 ADC clocks. 0101: 6 ADC clocks. 0110: 7 ADC clocks. 0111: 8 ADC clocks. 1000: 9 ADC clocks. 1001: 10 ADC clocks. 1010: 11 ADC clocks. 1011: 12 ADC clocks. 1100: 13 ADC clocks. 1101: 14 ADC clocks.</p>
[3:0] SST (cont'd)	<p>Sample Settling Time, INMODE=10 or 11 (continued) 1110: 15 ADC clocks. 1111: 16 ADC clocks.</p>

21.3.10. ADC Window Upper Threshold High Register

The ADC Window Upper Threshold High Register, shown in Table 245, contains the unsigned MSBs of the ADC window upper threshold. This register is used in conjunction with ADCUWINL to define the ADC window upper threshold.

Table 245. ADC Window Upper Threshold High Register (ADCUWINH)

Bits	7	6	5	4	3	2	1	0
Field	UWINH							
Reset	FFh							
R/W	R/W							
Address	F79h							

Bit	Description
UWINH	<p>ADC Window Upper Threshold High ADC Window Upper Threshold High is a function of RESOLUT. The data in this register is unsigned. Interrupt is asserted if the ADC result is greater than the value of UWINH and UWINL.</p>

Bit	Description (Continued)
RESOLUT = 0	
[7:4]	Reserved: these bits must be programmed to 0000.
[3:0]	0–F: The 4 MSBs of the last conversion result are compared against the 4 LSBs of this data register.
RESOLUT = 1	
[7:6]	Reserved: these bits must be programmed to 00.
[5:0]	00–3F: The 6 MSBs of the last conversion result are compared against the 6 LSBs of this data register.

21.3.11. ADC Window Upper Threshold Low Register

The ADC Window Upper Threshold Low Register, shown in Table 246, contains the unsigned LSBs of the ADC window upper threshold. This register is used in conjunction with ADCUWINH to define the ADC window upper threshold.

Table 246. ADC Window Upper Threshold Low Register (ADCUWINL)

Bits	7	6	5	4	3	2	1	0
Field	UWINL							
Reset	FFh							
R/W	R/W							
Address	F7Ah							

Bit	Description
UWINL	ADC Window Upper Threshold Low The data in this register is unsigned. Interrupt is asserted if the ADC result is greater than the value of UWINH and UWINL.
RESOLUT = x	
[7:0]	00–FF: The 8 LSBs of the last conversion result are compared against this data register.

21.3.12. ADC Window Lower Threshold High Register

The ADC Window Lower Threshold High Register, shown in Table 247, contains the unsigned MSBs of the ADC window lower threshold. This register is used in conjunction with ADCLWINL to set the ADC window lower threshold.

Table 247. ADC Window Lower Threshold High Register (ADCLWINH)

Bits	7	6	5	4	3	2	1	0
Field	LWINH							
Reset	00h							
R/W	R/W							
Address	F7Bh							

Bit	Description
LWINH	<p>ADC Window Lower Threshold High DC Window Lower Threshold High is a function of RESOLUT. The data in this register is unsigned. Interrupt is asserted if the ADC result is lower than the value of LWINH and LWINL.</p>
RESOLUT = 0	
[7:4]	Reserved: these bits must be programmed to 0000.
[3:0]	0–F: The 4 MSBs of the last conversion result are compared against the 4 LSBs of this data register.
RESOLUT = 1	
[7:6]	Reserved: these bits must be programmed to 00.
[5:0]	00–3F: The 6 MSBs of the last conversion result are compared against the 6 LSBs of this data register.

21.3.13. ADC Window Lower Threshold Low Register

The ADC Window Lower Threshold Low Register, shown in Table 248, contains the unsigned LSBs of the ADC window lower threshold. This register is used in conjunction with ADCLWINH to set the ADC window lower threshold.

Table 248. ADC Window Lower Threshold Low Register (ADCLWINL)

Bits	7	6	5	4	3	2	1	0
Field	LWINL							
Reset	00h							
R/W	R/W							
Address	F7Ch							

Bit	Description
LWINL	<p>ADC Window Lower Threshold Low</p> <p>The data in this register is unsigned. Interrupt is asserted if the ADC result is lower than the value of LWINH and LWINL.</p>
RESOLUT = x	
[7:0]	00–FF: The 8 LSBs of the last conversion result are compared against this data register.

Chapter 22. Digital-to-Analog Converter

The F6482 Series MCUs include a high-performance Digital-to-Analog Converter (DAC). This DAC converts a 12-bit digital input code to an analog output signal. The DAC offers the following features:

- 12-bit resolution
- Output driven externally on GPIO; internal connections to comparators and ADC
- Conversion initiated by software or Event System input
- Data buffering option
- Data can be left- or right-justified with either unsigned (binary) or signed (two's-complement) format
- DMA support
- Internal positive voltage reference selections of A_{VDD} or the DAC V_{REF} from the Reference System (2.5V, 2.0V, 1.5V, 1.25V) which is driven on V_{REF+} for decoupling
- Ability to utilize external reference voltage
- Three power settings providing programmable power vs. settling time; see the [Electrical Characteristics](#) chapter on page 601 to learn more

22.1. Architecture

The DAC architecture, shown in Figure 78, consists of a data register, an internal voltage reference buffer, and a 12-bit DAC.

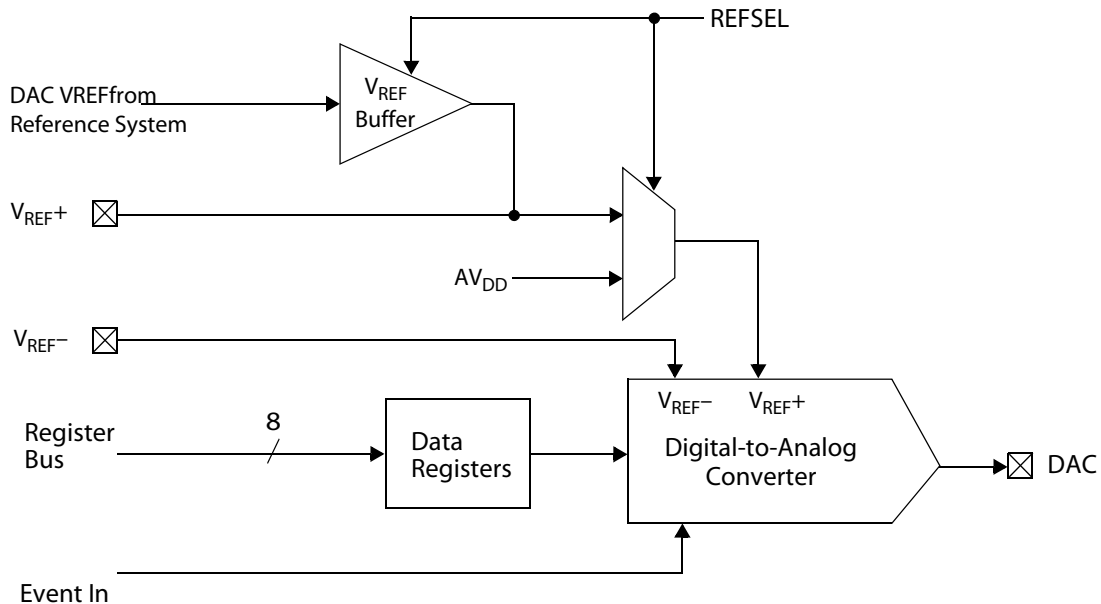

Figure 78. Digital-to-Analog Converter Block Diagram

22.2. Operation

The DAC is enabled by setting the DAC bit in the PWRCTL1 Register, which is described in the [Low-Power Modes](#) chapter on page 50. The DAC converts the digital input, DACDH and DACDL, in the DAC data registers, DACD_H and DACD_L, to an analog output level.

Data can be right-justified or left-justified, as selected by the JUSTIFY bit in the DACCTL Register. If data is left-justified, 8-bit resolution can be achieved by writing only the Data High Register, DACD_H.

The data format can be either unsigned (binary) or signed (two's-complement), as selected by the DFORMAT bit in the DACCTL Register. As shown in Figure 79, for unsigned data, 000h represents V_{REF-} , 7FFh represents midrange, and FFFh represents V_{REF+} . The equation for determining the analog level with unsigned data can be calculated as:

$$\text{DAC Output} = (V_{REF+} - V_{REF-}) \times (\text{data} \div 4095)$$

In this equation, *data* represents the value of {DACDH, DACDL}.

As Figure 79 shows for signed data, 800h represents V_{REF-} , 000h represents midrange, and 7FFh represents V_{REF+} . The equation for determining the analog level with signed data can be calculated as:

$$\text{DAC Output} = V_{MR} \times ((\text{data} + \text{FSR}) \div \text{FSR})$$

In this equation, *data* represents the value of {DACDH, DACDL}, V_{MR} is $(V_{REF+} - V_{REF-}) \div 2$, and FSR is -2048 for negative inputs and $+2047$ for positive inputs.

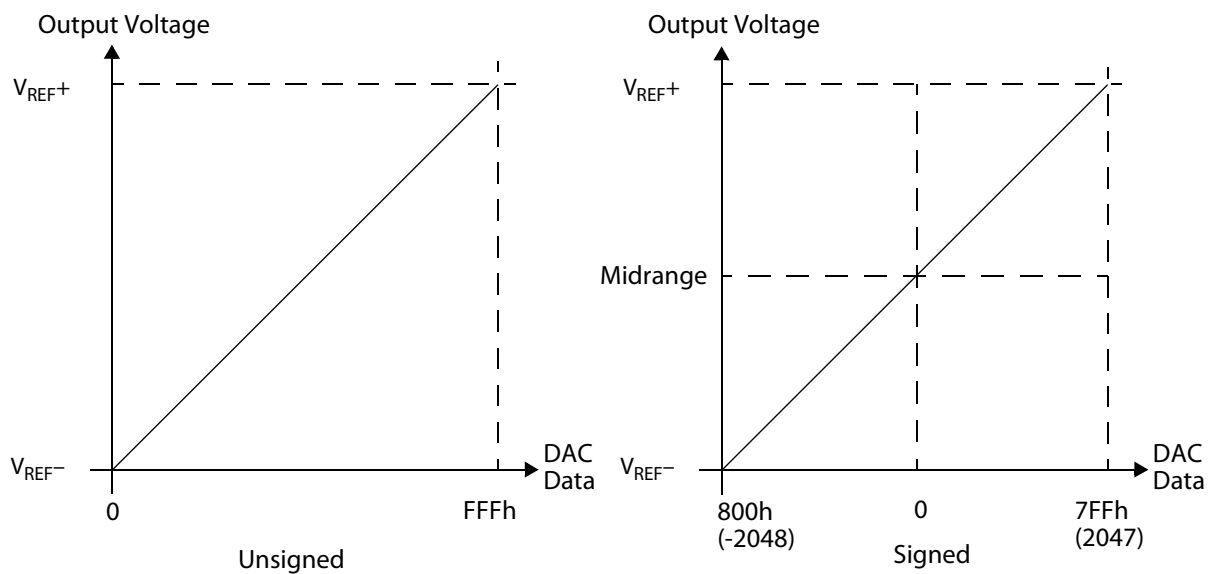

Figure 79. Output Voltage vs. DAC Data

The DAC output is available on a GPIO. Prior to enabling the DAC, select the DAC output using the GPIO alternate function registers, as described in the [General-Purpose Input/Output](#) chapter on page 55. The DAC will operate only if it is enabled, and the DAC output is selected using the GPIO alternate function registers. The DAC output on the GPIO is also selectable as an input to the comparators and the ADC.

22.2.1. Starting a Conversion

There are two methods for starting a conversion:

- Software or DMA write to the DACD_H Register (DACTRIG=0).
- Event System (DACTRIG=1). If new data exists in the data registers, data conversion is triggered by the assertion of the Event System input.

When the DAC is enabled, data existing in the data registers is converted. The data registers can be written while the DAC is disabled to provide the initial data word to be converted when the DAC is enabled.

Data can be right-justified or left-justified, as selected by the JUSTIFY bit in the DAC-CTL Register. If data is left-justified, 8-bit resolution can be achieved by writing only the Data High Register, DACD_H.

22.2.2. Power Control

The DAC is capable of performing conversions at three different power settings, as selected by the POWER bit. When POWER=00, the DAC runs at its highest current consumption and with the fastest settling time. When POWER=10, the DAC runs at its lowest current consumption and with the slowest settling time. The lower power consumption setting can reduce overall current consumption for applications with slower switching requirements.

22.2.3. Voltage References

DAC positive voltage reference selection options are selected by REFSEL to be one of the following:

- A_{VDD} (REFSEL=000)
- Internal voltage reference buffer connected to V_{REF+} (REFSEL=1xx) which buffers the DAC internal voltage reference from the Reference System
- External voltage reference on V_{REF+} (REFSEL=011)

The DAC negative reference should always be configured as V_{REF-} using the GPIO Alternate Function Selection, which is described in the [General-Purpose Input/Output](#) chapter on page 55. Unless using A_{VDD} (REFSEL=000), the DAC positive voltage reference should be configured as V_{REF+} using the GPIO Alternate Function selection. When using the internal voltage reference buffer connected to V_{REF+} (REFSEL=1xx), an external bypass capacitor is required. Typically, an external bypass capacitor is also employed for an external voltage reference on V_{REF+} (REFSEL=011).

The Reference System offers four possible internal voltage reference level settings that are also selected by REFSEL, namely: 1.25V, 1.5V, 2.0V, and 2.5V. Care should be exercised to ensure that A_{VDD} is always at least 0.5V greater than the selected internal voltage reference level. When the internal voltage reference buffer is selected, it is automatically enabled if both the DAC is enabled and the DAC output is selected using the GPIO alternate function registers.

The ADC voltage reference buffer can also be configured to connect to V_{REF+} . If both the ADC voltage reference buffer and the DAC voltage reference buffer are selected to connect to V_{REF+} , hardware will connect only the DAC voltage reference buffer to V_{REF+} .

22.2.4. DAC Interrupt and DMA

When conversions are started by an Event System input assertion (DACTRIG=1), the DAC asserts an interrupt request and a DMA request, thereby prompting the software or DMA to supply the next data word for conversion. A DAC DMA request is deasserted whenever the DACD_H Register is written by the DMA or the software, and whenever the DAC is disabled. Typically, the DMA is configured to have fixed word address control for the DMA destination address, and the destination address is configured to be the DACD_L Register address. DMA transfers to the DAC can also be performed when (DACTRIG=0) by selecting an appropriate DMA request source, such as a timer. An interrupt request that is pending when the DAC is disabled is not automatically cleared.

22.3. DAC Control Register Definitions

The registers that control digital-to-analog conversion functions are defined in this section.

22.3.1. DAC Control Register

The DAC Control Register, shown in Table 248, contains control for the DAC.

Table 248. DAC Control Register (DACCTL)

Bits	7	6	5	4	3	2	1	0
Field	POWER		REFSEL			DFORMAT	DACTRIG	JUSTIFY
Reset	0	0	0	0	0	0	0	0
R/W	R/W	R/W	R/W	R/W	R/W	R/W	R/W	R/W
Address	F7Dh							

Bit	Description
[7:6]	Power Control
POWER	00: Higher conversion speed, higher power consumption. 01: Moderate conversion speed, moderate power consumption. 10: Lower conversion speed, lower power consumption. 11: Reserved.

Bit	Description (Continued)
[5:3] REFSEL	<p>DAC Positive Voltage Reference Select</p> <p>If REFSEL = 1xx and the ADC is also configured to drive V_{REF+}, the DAC voltage reference buffer selection is used.</p> <p>000: Internal connection to AV_{DD}.</p> <p>001: Reserved.</p> <p>010: Reserved.</p> <p>011: V_{REF+} pin driven by an external source.</p> <p>100: 1.25V internal voltage reference from the Reference System is buffered and drives the V_{REF+} pin.</p> <p>101: 1.5V internal voltage reference from the Reference System is buffered and drives the V_{REF+} pin.</p> <p>110: 2.0V internal voltage reference from the Reference System is buffered and drives the V_{REF+} pin.</p> <p>111: 2.5V internal voltage reference from the Reference System is buffered and drives the V_{REF+} pin.</p>
[2] DFORMAT	<p>Data Format</p> <p>0: Data is unsigned (binary).</p> <p>1: Data is signed (two's complement).</p>
[1] DACTRIG	<p>DAC Triggering</p> <p>0: DAC conversion is triggered by a software or DMA write to the DACD_H register.</p> <p>1: DAC conversion is triggered by an Event System input. While converting the data, interrupt request and DMA request will be asserted allowing transfer of the next data word to be converted.</p>
[0] JUSTIFY	<p>Data Register Justification</p> <p>0: Data is left-justified.</p> <p>1: Data is right-justified.</p>

22.3.2. DAC Data High Register

The DAC Data High Register, shown in Table 249, contains the MSBs of the DAC data input. The justification of the bits in this register is defined by JUSTIFY. Writing the DAC Data High Register initiates a conversion if the DAC is enabled.

Table 249. DAC Data High Register (DACD_H)

Bits	7	6	5	4	3	2	1	0
Field	DACDH							
Reset	00h							
R/W	R/W							
Address	F7Eh							

Bit	Description
DACDH	DAC Data High The justification of data in this register is a function of JUSTIFY.
JUSTIFY = 0 (Left-Justified)	
[7:0]	00–FF: The 8 MSBs of the data to be converted are written to this data register.
JUSTIFY = 1 (Right-Justified)	
[7:4]	0–F: Reserved, and must be programmed to 0000.
[3:0]	0–F: The 4 MSBs of the data to be converted are written to the 4 LSBs of this data register.

22.3.3. DAC Data Low Register

The DAC Data Low Register, shown in Table 250, contains the LSBs of the DAC data input. The justification of the bits in this register is defined by JUSTIFY.

Table 250. DAC Data Low Register (DACD_L)

Bits	7	6	5	4	3	2	1	0
Field	DACDL							
Reset	00h							
R/W	R/W							
Address	F7Fh							

Bit	Description
DACDL	DAC Data Low The justification of data in this register is a function of JUSTIFY.
JUSTIFY = 0 (Left-Justified)	
[7:4]	0–F: The 4 LSBs of the data to be converted are written to the 4 MSBs of this data register.



Bit	Description (Continued)
[3:0]	0–F: Reserved, and must be programmed to 0000.
JUSTIFY = 1 (Right-Justified)	
[7:0]	00–FF: The 8 LSBs of the data to be converted are written to this data register.

Chapter 23. Operational Amplifiers

Two low-power operational amplifiers (op amps) are available with Zilog's F6482 Series MCUs: Op Amp A and Op Amp B. These amplifiers are identical to each other, but each has different selectable features. Op Amp A can be configured internally with various voltage gain settings, whereas Op Amp B can be configured internally as a current source/sink. Both op amps can be internally configured to provide unity gain feedback. Each op amp input and output is accessible from the package pins.

Features include:

- Two general-purpose op amps (Op Amp A and Op Amp B), individually enabled and configured
- Rail-to-rail inputs and outputs
- Two power vs. bandwidth settings featuring low active currents of 1 μA and 30 μA
- Flexible multiplexed op amp inputs and outputs
- Outputs can drive selectable internal destinations such as the ADC, comparators and op amp inputs without consuming a GPIO
- Internal input and output connections available to conserve pins
- Can be internally configured as a unity gain buffer
- Op Amp A can be configured as a programmable gain amplifier using an internal programmable resistive feedback network that provides 16 gain steps
- Op Amp B can be configured internally as a regulated current source or sink
 - Internal current levels typically configured as 10 μA , 100 μA , or 1 mA
 - High-accuracy current sourcing/sinking with external resistor

23.1. Architecture

Op Amp A and Op Amp B have identical amplifiers but have different selectable features. Figure 80 shows a simplified block diagram of Op Amp A, including input connections and feedback paths for unity gain and programmable gain.

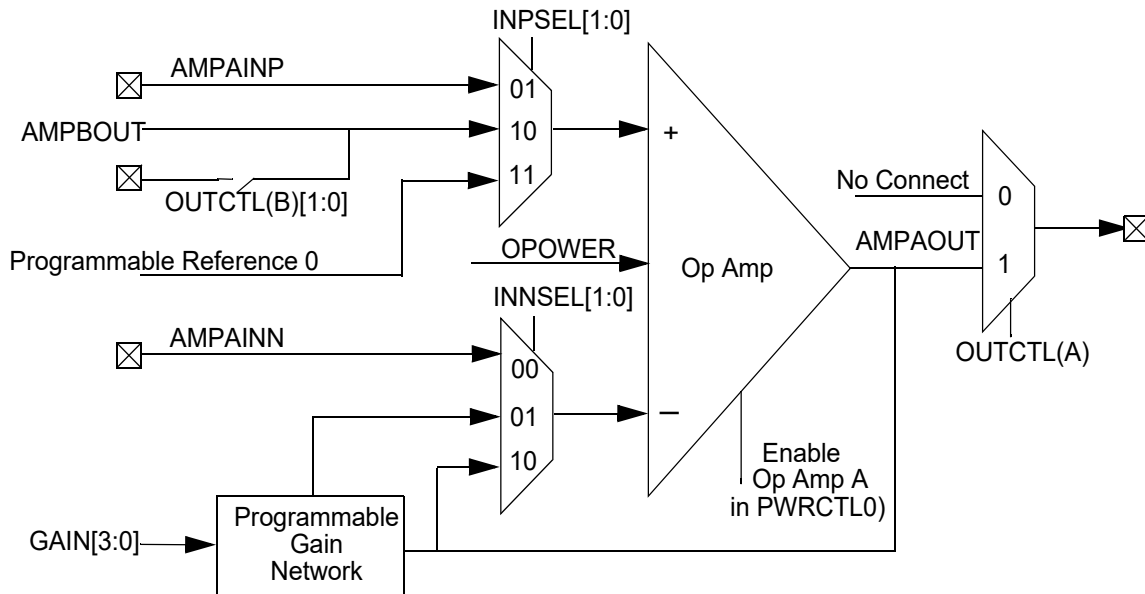

Figure 80. Op Amp A Block Diagram

Figure 81 shows a simplified block diagram of Op Amp B including input connections, a feedback path for unity gain, and programmable current drive network connections.

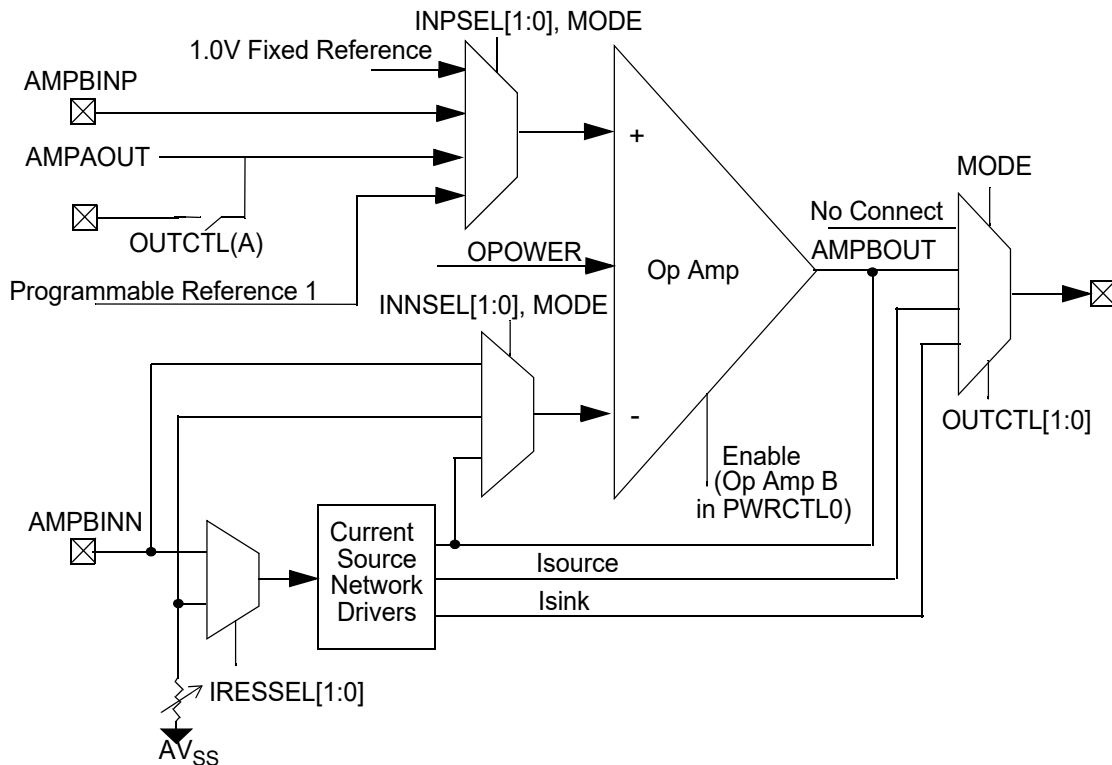

Figure 81. Op Amp B Block Diagram

23.2. Operation

The identical Op Amp A and Op Amp B amplifiers feature independent control, and provide rail-to-rail operation for both inputs and outputs. They are enabled by setting OpAmpA and OpAmpB, respectively, in the PWRCTL0 Register, which is described in the [Low-Power Modes](#) chapter on page 50. If enabled, an amplifier remains active in all modes, even in Stop Mode. If the amplifier is not required in Stop Mode, disable it. Failing to disable it results in higher Stop Mode current than necessary.

Op amp power consumption and bandwidth can be adjusted by setting or clearing the OPOWER bit. The OPOWER bits for both op amps are OR'ed such that both op amps will operate with normal power/bandwidth if either OPOWER bit is set. Low power/bandwidth, nominally 1 μ A and 40kHz unity gain bandwidth, is selected by clearing this OPOWER bit, whereas normal power/bandwidth, nominally 30 μ A and 620kHz unity gain bandwidth, is selected by setting OPOWER. With these settings, the op amps can support many analog front-end sensing applications, providing signal conditioning ahead of any digital conversion with the integrated ADC or comparators.

All inputs and outputs can be selected to connect to assigned GPIO pins to support user external feedback and coupling networks to meet analog front-end acquisition requirements. To connect GPIOs to an op amp, configure the appropriate alternate function, as described in the [General-Purpose Input/Output](#) chapter on page 55, and configure the OUTCTL bit. In addition, to reduce the demand for external pins or components, op amps can be configured for the following internal connections:

- Unity gain buffer
- Programmable gain amplifier using an internal programmable gain network (Op Amp A)
- Current sink or source using an internal current drive network (Op Amp B)
- Inputs from the reference system, including the internal programmable references and the 1.0V internal fixed reference (Op Amp B)
- Outputs to op amp inputs, Comparator 0, Comparator 1, and the ADC

The internal connections can also improve performance by eliminating external board and connectivity from loading while going off- and on-chip.

Op amp positive inputs are selected with the INPSEL bit, and op amp negative inputs are selected with the INNSEL bit. The op amp outputs, AMPAOUT and AMPBOUT, share package pin connections with ADC inputs. When making an ADC measurement that does not involve an op amp on such a shared pin, either disable the op amp or disconnect it from the GPIO with the appropriate OUTCTL setting.

The unique features that mate to each op amp are described in the Op Amp A section that follows, and in the [Op Amp B](#) section on page 478.

23.2.1. Op Amp A

Op Amp A can be configured internally for unity gain or as a noninverting programmable gain amplifier with 16 available gain selections, 1.5x to 64x, that are selected by writing to the GAIN bit. As shown in [Figure 80](#) on page 475, three positive and three negative inputs are available. The positive Op Amp A inputs are selected with the INPSEL bit in the AMPACTL0 Register, and include:

- A GPIO pin used as the Op Amp A positive input, AMPAINP
- Op Amp B output. This selection provides an internal connection that does not involve the GPIO used as the Op Amp B output, AMPBOUT
- Internal Programmable Reference 0, with level selected by the PREFLVL bit, and source selected by the PREFSRC bit in the CMP0CTL1 Register; see [Table 259](#) on page 496 to learn more

The negative Op Amp A inputs are selected with the INNSEL bit in the AMPACTL1 Register, and include:

- GPIO pin used as Op Amp A negative input, AMPAINN
- Op Amp A output through internal feedback network using an internal connection with gain, defined by the GAIN bit
- Op Amp A output, a unity gain configuration using an internal connection

The Op Amp A output, AMPAOUT, can be selected as an internal input to OPAMP B, Comparator 0, Comparator 1, and the ADC. Additionally, it can be connected to the GPIO used as AMPAOUT by setting the OUTCTL bit in the AMPACTL0 Register, and configuring the appropriate alternate function, as described in the [General-Purpose Input/Output](#) chapter on page 55. This GPIO can also be selected as an input to the ADC.

23.2.2. Op Amp B

As shown in [Figure 81](#) on page 476, four positive and three negative inputs are available. The positive Op Amp B inputs are selected with the INPSEL bit in the AMPBCTL0 Register, and include:

- 1.0V from the Reference System; see the [Comparators and Reference System](#) chapter on page 486 to learn more
- A GPIO pin used as the Op Amp B positive input, AMPBINP
- Op Amp A output. This selection provides an internal connection that does not involve the GPIO used as the Op Amp A output, AMPAOUT
- Internal Programmable Reference 1, with level selected by the PREFLVL bit and source selected by the PREFSRC bit in the CMP1CTL1 Register; see [Table 261](#) on page 498 to learn more

The negative Op Amp B inputs are selected with the INNSEL and MODE bits in the AMPBCTL1 Register, and include:

- A GPIO pin used as the Op Amp B negative input, AMPBINN
- An internal connection from the current drive network
- Op Amp B output, a unity gain configuration using an internal connection

The Op Amp B output, AMPBOUT, can be selected as an internal input to Op Amp A and the ADC. Additionally, it can be connected to the GPIO used as AMPBOUT by selecting OUTCTL=11 in the AMPBCTL0 Register and configuring the appropriate alternate function, as described in the [General-Purpose Input/Output](#) chapter on page 55. This GPIO can also be selected as an input to Comparator 0, Comparator 1, and the ADC.

Op Amp B can be configured internally as a current source/sink or to provide unity gain. When AMPBCTL1 Register MODE=1, the op amp is configured as a current source/sink with Programmable Reference 1 selected as the positive input, regardless of the INPSEL setting.

To develop the source/sink current, Op Amp B imposes the Programmable Reference 1 level across a current drive set point resistor. If IRESSEL=00, AMPBINN is selected for an external resistor connection from AMPBINN to AV_{SS}. otherwise, the remaining IRESSEL settings select one of three internal resistors.

Figure 82 depicts Op Amp B connections when Op Amp B is configured as a current source (MODE=1). The magnitude of the output current is calculated using the following equation:

$$I_{OUT} = V_{PREF1} \div R$$

In this equation, I_{OUT} is the Op Amp B output current, V_{PREF1} is the Programmable Reference 1 voltage, and R is the resistance of the resistor selected.

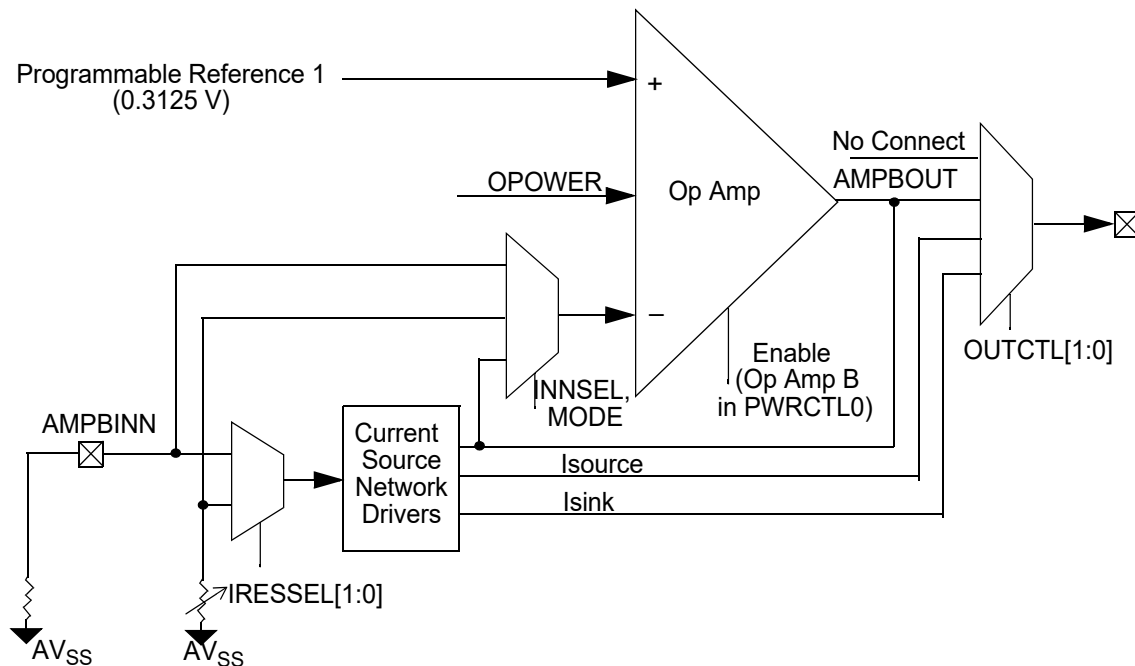

Figure 82. Op Amp B Connections for Current Sourcing/Sinking

When using the internal resistor for current source/sink capability, the Programmable Reference 1 level is typically configured to be 0.3125 V. The three internal current drive network resistor options are: 31.25 KΩ, 3.125 KΩ, and 312.5 Ω (nominal), which results in

available current levels of 10 μ A, 100 μ A, and 1 mA, respectively. The 1mA level is not recommended for AVDD < 3V. When using an external resistor, R_{EXT}, and a Programmable Reference 1 level of 0.3125 V, the current will be 0.3125 V \div R_{EXT}. The current should not exceed 1.2mA, and the Programmable Reference 1 level should not exceed AVDD – 1 V.

The current levels provided by the internal resistors differ by 10x, which can be convenient for applications such as temperature diode measurement. By taking two voltage measurements at 10x different currents, the absolute temperature is directly proportional to the difference in the sensed diode voltages and natural log of the current ratio (10:1). This application (force current and sense voltage) can be accomplished with only one package pin if sensing with the ADC or, alternatively, with two package pins when sensing with Op Amp A.

The current drive network is connected to AMPBOUT by selecting the appropriate GPIO alternate function and writing OUTCTL=01 for the current source, or OUTCTL=10 for the current sink.

23.3. Op Amp Register Definitions

The four op amp registers are briefly summarized in Table 251; their bits are defined in [Tables 252 through 255](#).

Table 251. Op Amp Register Summary

Name	Address	Description
AMPACTL0	F94h	Configuration for Op Amp A
AMPACTL1	F95h	Programmable Gain & Configuration for Op Amp A
AMPBCTL0	F96h	Configuration for Op Amp B
AMPBCTL1	F97h	Source/Sink Current & Configuration for Op Amp B

23.3.1. Op Amp A Control 0 Register

The Op Amp A Control 0 Register, shown in Table 252, contains configuration for Op Amp A.

Table 252. Op Amp A Control 0 Register (AMPACTL0)

Bit	7	6	5	4	3	2	1	0	
Field	OUTCTL	Reserved					INPSEL		
Reset	0	0	0	0	0	0	0	0	
R/W	R/W	R/W	R/W	R/W	R/W	R/W	R/W	R/W	
Address	F94h								

Bit	Description
[7] OUTCTL	<p>Output Control</p> <p>0: Op Amp A output is disconnected from the GPIO used as AMPAOUT. AMPAOUT can be selected as an internal input to OPAMP B, Comparator 0, Comparator 1, and the ADC without consuming a GPIO.</p> <p>1: Op Amp A output is connected to the GPIO used as AMPAOUT. It is also necessary to configure the appropriate alternate function, as described in the General-Purpose Input/Output chapter on page 55. This GPIO can also be selected as an input to the ADC.</p>
[6:2]	<p>Reserved</p> <p>These bits are reserved and must be programmed to 00000.</p>
[1:0] INPSEL	<p>Positive Input Signal Select</p> <p>00: Reserved; no connection.</p> <p>01: GPIO pin used as Op Amp A positive input, AMPAINP.</p> <p>10: Op Amp B output. This selection provides an internal connection that does not involve the GPIO used as Op Amp B output, AMPBOUT.</p> <p>11: Internal Programmable Reference 0, with level selected by PREFLVL and source selected by PREFSRC in the CMP0CTL1 Register; see the Comparator 0 Control 1 Register (CMP0CTL1) on page 496 to learn more.</p>

23.3.2. Op Amp A Control 1 Register

The Op Amp A Control 1 Register, shown in Table 253, contains configuration for programmable gain and Op Amp A.

Table 253. Op Amp A Control 1 Register (AMPACTL1)

Bit	7	6	5	4	3	2	1	0
Field	GAIN				OPOWER	Reserved	INNSEL	
Reset	0	0	0	0	0	0	0	0
R/W	R/W	R/W	R/W	R/W	R/W	R	R/W	R/W
Address	F95h							

Bit	Description
[7:4] GAIN	<p>Internal Voltage Gain Setting GAIN is effective only when INNSEL=01.</p> <p>0000: 1.5x. 0001: 2.0x. 0010: 2.5x. 0011: 3.0x. 0100: 3.75x. 0101: 4.0x. 0110: 5.0x. 0111: 6.0x. 1000: 7.5x. 1001: 8.0x. 1010: 10x. 1011: 12x. 1100: 15x. 1101: 20x. 1110: 30x. 1111: 60x.</p>
[3] OPOWER	<p>Op Amp Power/Speed Select 0: Low power, 1µA current, 40kHz unity gain bandwidth (nominal values). 1: Normal power, 30µA current, 620kHz unity gain bandwidth (nominal values). Note: This bit is OR'ed with the Op Amp B OPOWER bit such that if either OPOWER bit is set, both op amps will operate with normal power.</p>
[2]	<p>Reserved This bit is reserved and must be programmed to 0.</p>
1:0 INNSEL	<p>Negative Input Signal Select 00: GPIO pin used as Op Amp A negative input, AMPAINN. 01: Op Amp A output through internal gain network using internal connection with gain defined by GAIN. 10: Op Amp A output, unity gain configuration using internal connection. 11: Reserved.</p>

23.3.3. Op Amp B Control 0 Register

The Op Amp B Control 0 Register, shown in Table 254, contains configuration for Op Amp B.

Table 254. Op Amp B Control 0 Register (AMPBCTL0)

Bit	7	6	5	4	3	2	1	0
Field	OUTCTL		Reserved				INPSEL	
Reset	0	0	0	0	0	0	0	0
R/W	R/W	R/W	R/W	R/W	R/W	R/W	R/W	R/W
Address	F96h							

Bit	Description
[7:6]	Output Control
OUTCTL	OUTCTL is dependent upon the value of MODE. MODE=0 00–10: Op Amp B output is disconnected from the GPIO used as AMPBOUT. AMPBOUT can be selected as an internal input to OPAMP A and the ADC without consuming a GPIO. 11: Op Amp B output is connected to the GPIO used as AMPBOUT. Additionally, configure the appropriate alternate function, as described in the General-Purpose Input/Output chapter on page 55. MODE=1 00, 11: Op Amp B output is disconnected from the GPIO used as AMPBOUT. 01: Internal current source connects to the GPIO used as AMPBOUT. Also, configure the appropriate alternate function, as described in the General-Purpose Input/Output chapter on page 55. 10: Internal current sink connects to the GPIO used as AMPBOUT. Additionally, configure the appropriate alternate function, as described in the General-Purpose Input/Output chapter on page 55.

Bit	Description (Continued)
[5:2]	Reserved These bits are reserved and must be programmed to 0.
[1:0] INPSEL	Positive Input Signal Select INPSEL is dependent upon the value of MODE MODE=0 00: 1.0V (nominal) reference from the Reference System. 01: GPIO pin used as Op Amp B input, AMPBINP. 10: Op Amp A output. This selection provides an internal connection that does not involve the GPIO used as the Op Amp A output, AMPAOUT. 11: Internal Programmable Reference 1, with level selected by the PREFLVL bit and source selected by the PREFSRC bit in the CMP1CTL1 Register; see the Comparator 1 Control 1 Register (CMP1CTL1) on page 498 to learn more. MODE=1 xx: Internal Programmable Reference 1, with level selected by the PREFLVL bit and source selected by the PREFSRC bit in the CMP1CTL1 Register; see the Comparator 1 Control 1 Register (CMP1CTL1) on page 498 to learn more.

23.3.4. Op Amp B Control 1 Register

The Op Amp B Control 1 Register, shown in Table 255, contains the configuration for current sourcing/sinking and for Op Amp B.

Table 255. Op Amp B Control 1 Register (AMPBCTL1)

Bit	7	6	5	4	3	2	1	0
Field	Reserved		IRESSEL		OPOWER	Reserved	INNSEL	MODE
Reset	0	0	0	0	0	0	0	0
R/W	R	R	R/W	R/W	R/W	R	R/W	R/W
Address	F97h							

Bit	Description
[7:6]	Reserved These bits are reserved and must be programmed to 00.
[5:4] IRESSEL	Current Source Resistor Select RESSEL is meaningful only when MODE=1 00: External resistor, connected to the GPIO used as Op Amp B negative input, AMPBINN, forms current drive set point. 01: Internal 31.25KΩ (nominal) resistor forms current drive set point and provides 10μA*. 10: Internal 3.125KΩ (nominal) resistor forms current drive set point and provides 100μA*. 11: Internal 312.5Ω (nominal) resistor forms current drive set point and provides 1.0mA*. The Op Amp B IRESSEL = 11 setting is not recommended for AV _{DD} < 3V
[3] OPOWER	Op Amp Power/Speed Select 0: Low power, 1μA current, 40kHz unity gain bandwidth (nominal values). 1: Normal power, 30μA current, 620kHz unity gain bandwidth (nominal values). Note: This bit is OR'ed with the Op Amp A OPOWER bit such that if either OPOWER bit is set, both op amps will operate with normal power.
[2]	Reserved This bit is reserved and must be programmed to 0.
[1] INNSEL	Negative Input Signal Select INNSEL is dependent upon the value of MODE MODE=0 0: GPIO pin used as Op Amp B negative input, AMPBINN. 1: Op Amp B output, unity gain configuration. MODE=1 x: Connection to current drive set point resistor selected by IRESSEL.
[0] MODE	Mode 0=Normal mode, INNSEL bit selects the Op Amp B negative input. 1=Current drive mode, INNSEL has no effect.

Note: *Assumes the Programmable Reference 1 level is 0.3125 V.

Chapter 24. Comparators and Reference System

The F6482 Series devices feature a reference system and two identical general-purpose, rail-to-rail comparators, each of which compares two analog input signals with four speed-vs.-power settings and three hysteresis options. A 4-to-1 input multiplexer exists on each comparator positive input and each comparator negative input. Multiplexing can be configured such that a GPIO (C0INP/C1INP) pin provides a positive comparator input and/or a GPIO (C0INN/C1INN) provides a negative input. The output of each comparator is available as an interrupt source and can be routed to an external pin using the GPIO multiplex, as well as to the Event System.

Features for each comparator include:

- Positive input selections offering a GPIO, a temperature sensor and op amp outputs AMPAOUT and AMPBOUT
- Negative input selections offering a GPIO, fixed internal reference levels, a programmable internal reference, and the DAC
- Output can be an interrupt source
- Output can drive an external pin and/or be an Event System source
- Operation in Stop Mode
- Power-vs.-speed control with four available settings
- Hysteresis control with three available settings
- Window detection: signal above window, signal inside window, signal below window
- Additional output in the form of a logical OR of each comparator output, is an Event System source, is useful for window detection signaling

Features of the Reference System are as follows:

- Reference Generator:
 - Fixed reference voltages including: the bandgap voltage, $AV_{DD}/2$, 0.75 V, 1.0 V, and 1.25 V, that are available to certain internal functions
 - VBIAS with four selectable levels (2.5 V, 2.0 V, 1.5 V, 1.25 V) that is available as an internal positive voltage reference for the ADC and as a GPIO alternate function to provide a low-power external reference
 - DAC internal positive voltage reference with four selectable levels (2.5 V, 2.0 V, 1.5 V, 1.25 V)
- Two programmable references provide 32 taps (steps), with the highest tap selectable as either VBIAS or AV_{DD}

24.1. Architecture

Figure 83 shows a simplified block diagram of the comparators, including input and output connections. Each of the two comparators is identical.

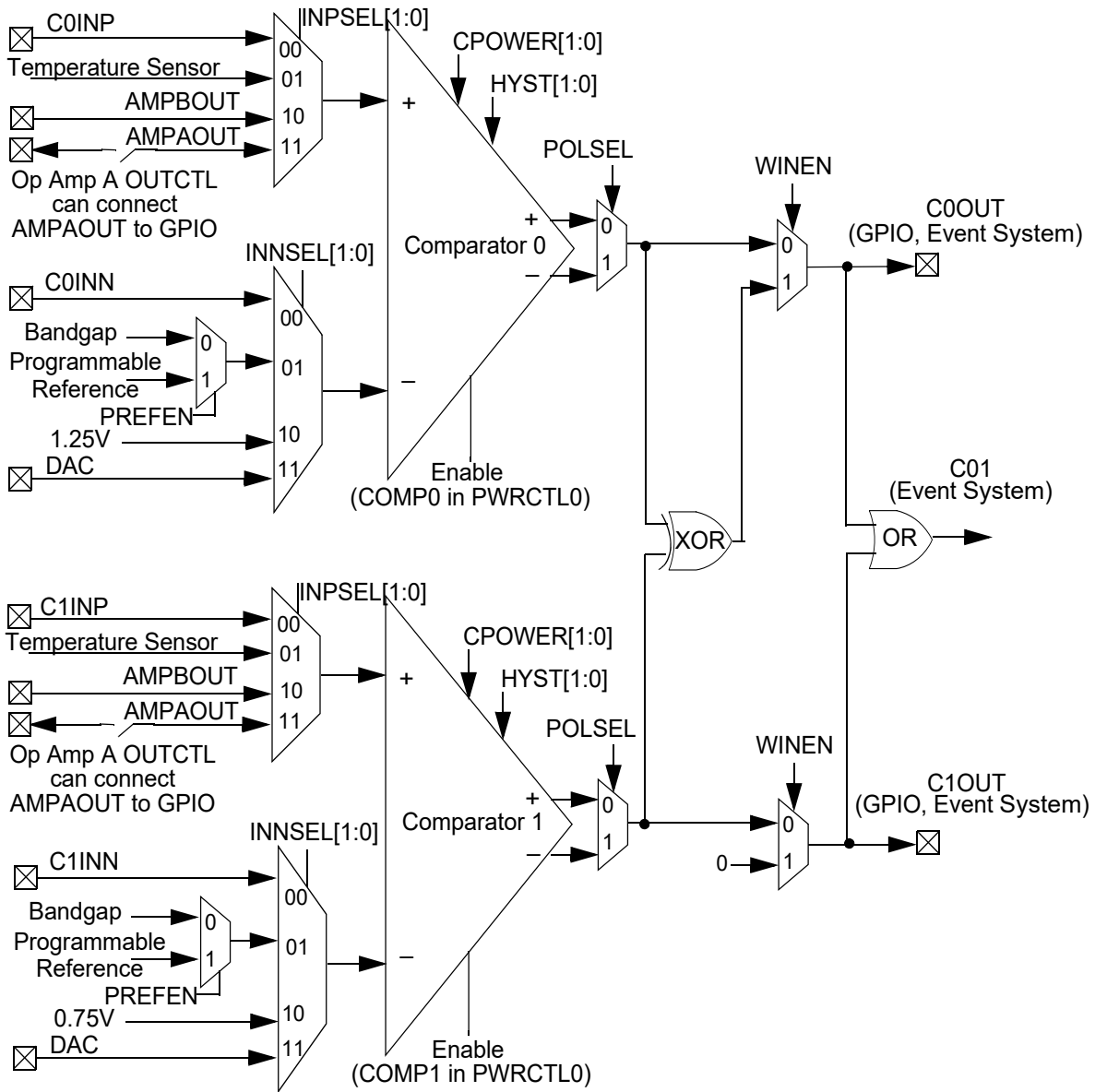

Figure 83. Comparators Block Diagram

Figure 84 shows a simplified block diagram of the Reference System, which includes the Reference Generator and two programmable references.

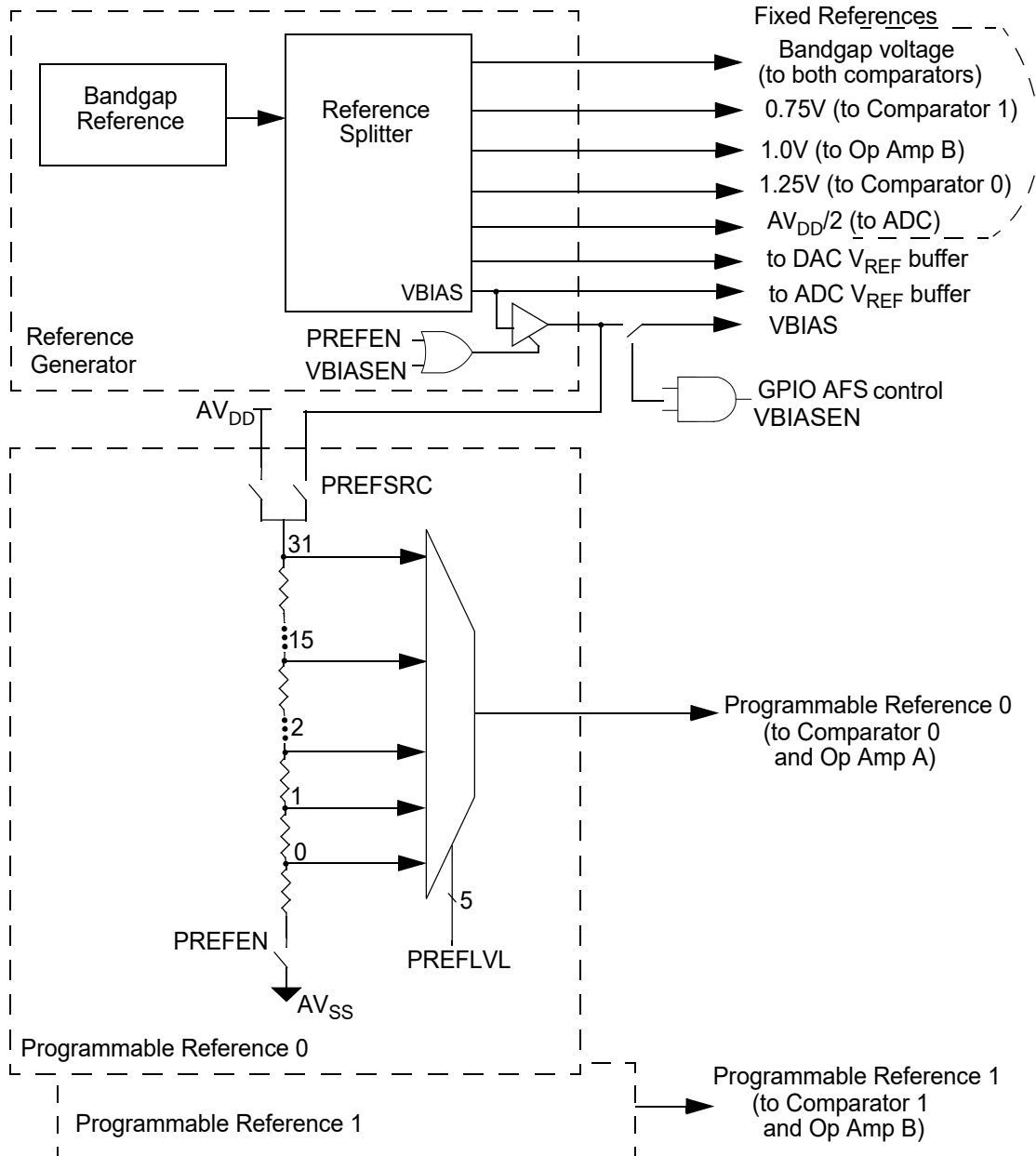

Figure 84. Reference System Block Diagram

24.2. Comparator Operation

Two identical general-purpose CMOS analog comparators each provide rail-to-rail operation with four speed-vs.-power settings and three hysteresis options. These comparators are enabled by setting the COMP0 and COMP1 bits in the PWRCTL0 Register, which is described in the [Low-Power Modes](#) chapter on page 50. The power setting is determined by the CPOWER bit, which selects current consumption ranging from 27 μ A, with a propagation delay of 150ns, to 0.2 μ A, with a propagation delay of 10 μ s. The low power settings can allow for continuous comparator usage in low-power systems. Hysteresis is selected by the HYST bit; selections range from no hysteresis to 40mV.

A 4-to-1 input multiplexer exists on each comparator positive input and each comparator negative input. The positive input is selected using the INPSEL bit to be either the temperature sensor, GPIO or one of the op amp outputs, AMPAOUT or AMPBOUT. The negative input is selected using the INNSEL and PREFEN bits to be either a GPIO, a fixed reference (0.75V/1.25V), the bandgap voltage, a programmable internal reference or the DAC output. Multiplexing can be configured such that a GPIO (C0INP/C1INP) pin provides the positive comparator input and/or a GPIO (C0INN/C1INN) provides the negative input. When connecting to GPIO, use the appropriate GPIO alternate function selection, as described in the [General-Purpose Input/Output](#) chapter on page 55.

The comparator output polarity is determined by the POLSEL bit. When POLSEL=0, the comparator output is noninverted such that the comparator output is High when the positive comparator input voltage is greater than the negative comparator input voltage. When POLSEL=1, the comparator output is inverted such that the comparator output is Low when the positive comparator input voltage is greater than the negative comparator input voltage.

The output of each comparator can be routed to a GPIO pin, C0OUT or C1OUT, as well as to the Event System. When connecting to GPIO, use the appropriate GPIO alternate function selection, as described in the [General-Purpose Input/Output](#) chapter on page 55. Additionally, the comparator output state can be read directly from the CSTATUS bit in the COMPCTL Register. An additional output, C01, is the logical OR of each comparator output, and is an Event System source; it is useful for window detection signaling.

A window compare feature provides coordinated detection reporting for the two comparators. WINEN=1 selects Window Mode. The impact of WINEN and POLSEL on the comparator outputs is summarized in [Table 256](#) on page 490.

Table 256. Effect of WINEN and POLSEL on Comparator Outputs

POLSEL		Input Condition (Positive Input vs. Negative Input)		WINEN=0				WINEN=1			
COMP0	COMP1	COMP0	COMP1	C0 OUT	C1 OUT	C01	CSTAT	C0 OUT	C1 OUT	C01	CSTAT, Window State*
0 (noninv)	0 (noninv)	+ < -	+ < -	0	0		00	0	0	0	01, Below
		+ < -	+ > -	0	1	1	01	1	0	1	00, Inside
		+ > -	+ < -	1	0	1	10	1	0	1	00, Inside
		+ > -	+ > -	1	1	1	11	0	0	0	10, Above
0 (noninv)	1 (inv)	+ < -	+ < -	0	1	1	01	1	0	1	00, Inside
		+ < -	+ > -	0	0	0	00	0	0	0	01, Below
		+ > -	+ < -	1	1	1	11	0	0	0	10, Above
		+ > -	+ > -	1	0	1	10	1	0	1	00, Inside
1 (inv)	0 (noninv)	+ < -	+ < -	1	0	1	10	1	0	1	00, Inside
		+ < -	+ > -	1	1	1	11	0	0	0	10, Above
		+ > -	+ < -	0	0	0	00	0	0	0	01, Below
		+ > -	+ > -	0	1	1	01	1	0	1	00, Inside
1 (inv)	1 (inv)	+ < -	+ < -	1	1	1	11	0	0	0	10, Above
		+ < -	+ > -	1	0	1	10	1	0	1	00, Inside
		+ > -	+ < -	0	1	1	01	1	0	1	00, Inside
		+ > -	+ > -	0	0	0	00	0	0	0	01, Below

Note: *Window state naming is from the perspective of noninverted polarity (POLSEL = 0) for both comparators.

In support of Window Mode, the positive input for both comparators can be configured to be a common signal in the following three ways:

- Select Op Amp A as the positive input for both comparators.
- Select the GPIO used for AMPBOUT as the positive input for both comparators. Op Amp B can be enabled to drive the inputs or disabled to allow for external drive of the inputs.
- Select C0INP as the positive input for COMP0 and C1INP as the positive input for COMP1; connect C0INP and C1INP externally.

The comparator outputs are used to provide interrupts, as described in the [Interrupt Controller](#) chapter on page 127.

The comparator can be powered down to save supply current or can continue to operate in Stop Mode. For details, see the [Power Control Register 0](#) on page 52. In Stop Mode, the comparator interrupt, if enabled, automatically initiates a Stop-Mode Recovery and generates an interrupt request. In the [Reset Status Register \(RSTSTAT\)](#) (see page 48), the stop bit is set to 1. Additionally, the Comparator request bit in the [Interrupt Request 2 Register](#) (see page 135) is set. Following completion of the Stop-Mode Recovery, and if interrupts are enabled, the CPU responds to the interrupt request by fetching the comparator interrupt vector.



Caution: Because of the propagation delay of the comparator, spurious interrupts can result after enabling the comparator. Zilog recommends not enabling the comparator without first disabling interrupts, then waiting for the comparator output to settle.

The following code example shows how to safely enable the comparator:

```
di
ldx CMP0CTL0,r0 ; set-up comparator
ldx CMP0CTL1,r1 ; set-up comparator
ldx PWRCTL0,r2  ; enable comparators
nop
nop             ; wait for output to settle
ldx IRQ2,#0    ; clear any spurious interrupts pending
ei
```

24.3. Reference System Operation

The Reference System provides predetermined fixed voltage levels and two programmable references that provide user-selectable voltage levels. Features of the Reference System include:

- Reference Generator:
 - Fixed reference voltages including: the bandgap voltage, $AV_{DD}/2$, 0.75V, 1.0V, and 1.25V, that are available to certain internal functions
 - VBIAS with four selectable levels (2.5V, 2.0V, 1.5V, 1.25V) that is available as an internal positive voltage reference for the ADC and as a GPIO alternate function to provide a low-power external reference
 - DAC internal positive voltage reference with four selectable levels (2.5V, 2.0V, 1.5V, 1.25V)
- Two programmable references provide 32 taps (steps), with the highest tap selectable as either VBIAS or AV_{DD}

The Reference Generator behavior during Normal Mode and Halt Mode is as follows:

- Fixed reference voltages are always available
- VBIAS is available if any of the following conditions are true:
 - VBIASEN is set in the CMPCTL Register
 - A programmable reference is enabled
 - An internal reference voltage is selected for the ADC
 - An internal reference voltage is selected for the DAC and the DAC is enabled

To output VBIAS on the VBIAS pin, select the corresponding GPIO alternate function and set the VBIASEN bit in the CMPCTL Register.

- The DAC V_{REF} is available if an internal reference voltage is selected for the DAC and the DAC is enabled

The Reference Generator behavior during Stop Mode is as follows:

- Fixed reference voltages are available if FRECOV=1
- VBIAS is available if FRECOV=1 and any of the following conditions are true:
 - VBIASEN is set in the CMPCTL Register
 - A programmable reference is enabled by setting PREFEN and clearing the PREFSRC in the CMPxCTL1 Register
 - An internal reference voltage is selected for the ADC.

To output VBIAS on the VBIAS pin, select the corresponding GPIO alternate function and set the VBIASEN bit in the CMPCTL Register.

When enabled, the Reference Generator provides low current consumption. In addition, any particular fixed reference is automatically enabled upon selection in the function that uses the fixed reference.

Each internal programmable reference features an independent enable, PREFEN, that eliminates current consumption if a particular programmable reference is not required. Each programmable reference can drive its assigned comparator and/or its assigned op amp. Programmable Reference 0 can be selected as an input to Comparator 0 and/or Op Amp A. Programmable Reference 1 can be selected as an input to Comparator 1 and/or Op Amp B.

Each programmable reference provides 32 levels, selectable with PREFLVL. The uppermost level can be selected as VBIAS from the Reference Generator (PREFSRC=0) or selected as A_{VDD} (PREFSRC=1). The level of the VBIAS is determined by REFLVL in the ADCCTL2 Register; see the [Analog-to-Digital Converter](#) chapter on page 439 for details. VBIAS also serves as a voltage reference for the ADC and VBIAS pin.

24.4. Comparator and Reference System Register Definitions

This section defines the features of the following Comparator and Reference System registers:

[Comparator Control Register \(CMPCTL\)](#) at address F8Fh

[Comparator 0 Control 0 Register \(CMP0CTL0\)](#) at address F90h

[Comparator 0 Control 1 Register \(CMP0CTL1\)](#) at address F91h

[Comparator 1 Control 0 Register \(CMP1CTL0\)](#) at address F92h

[Comparator 1 Control 1 Register \(CMP1CTL1\)](#) at address F93h

24.4.1. Comparator Control Register

The Comparator Control Register, shown in Table 257, provides global control to both comparators.

Table 257. Comparator Control Register (CMPCTL)

Bit	7	6	5	4	3	2	1	0
Field	VBIASEN	Reserved			Reserved	WINEN	CSTATUS	
Reset	0	0	0	0	0	0	0	0
R/W	R/W	R	R	R	R/W	R/W	R	R
Address	F8Fh							

Bit	Description
[7] VBIASEN	VBIAS Enable VBIAS is automatically enabled in Normal and Halt modes whenever VBIASEN is set, an internal programmable reference is enabled or the buffered VBIAS is selected as the positive reference voltage for the ADC. To make VBIASEN available to the VBIAS pin as a GPIO alternate function, VBIASEN must be set. 0: VBIAS disabled. 1: VBIAS enabled. VBIAS should also be selected using the GPIO alternate function registers if the VBIAS pin is to be driven by VBIAS.
[6:4]	Reserved These bits are reserved and must be programmed to 000.
[3]	Reserved This bit is reserved and must be programmed to 0.
[2] WINEN	Window Mode Enable 0: Normal mode, Comparator output (COUT), STATUS and comparator interrupts are based on independent comparators. 1: Window Mode. Comparator output (COUT), STATUS and comparator interrupts are based on a window logic function of both comparators.

Note: *C0OUT and C1OUT include the effect of POLSEL.

Bit	Description (Continued)
[1:0] CSTATUS	<p>Comparator Status Status is dependent upon the state of WINEN.</p> <p>WINEN=0 0x: Comparator 0 Output (C0OUT) is Low*. 1x: Comparator 0 Output (C0OUT) is High*. x0: Comparator 1 Output (C1OUT) is Low*. x1: Comparator 1 Output (C1OUT) is High*.</p> <p>WINEN=1 Window state naming is from the perspective of noninverted polarity (POLSEL = 0) for both comparators 00: Inside Window (C0OUT ≠ C1OUT)*. 01: Below Window (C0OUT=C1OUT=0)*. 10: Above Window (C0OUT=C1OUT=1)*. 11: Reserved.</p>

Note: *C0OUT and C1OUT include the effect of POLSEL.

24.4.2. Comparator 0 Control 0 Register

The Comparator 0 Control 0 Register is shown in Table 258.

Table 258. Comparator 0 Control 0 Register (CMP0CTL0)

Bit	7	6	5	4	3	2	1	0
Field	CPOWER		HYST		INNSEL		INPSEL	
Reset	0	0	0	0	0	0	0	0
R/W	R/W	R/W	R/W	R/W	R/W	R/W	R/W	R/W
Address	F90h							

Bit	Description
[7:6] CPOWER	<p>Comparator Power/Speed Select 00: Ultra-low power, current= 200nA, Tpd=10µs (nominal values). 01: Low power, current=1µA, Tpd=1.5µs (nominal values). 10: Normal, current =4µA, Tpd= 700ns (nominal values). 11: High Speed/Power, current = 27µA, Tpd =150ns (nominal values).</p>
[5:4] HYST	<p>Hysteresis Level Select 00: None, 0mV. 01: 15mV (nominal). 10: Reserved. 11: 40mv (nominal).</p>

Bit	Description (Continued)
[3:2]	Negative Input Signal Select
INNSEL	00: GPIO pin used as Comparator 0 negative input, C0INN. 01: If PREFEN=0, bandgap reference from the Reference Generator. If PREFEN=1, Programmable Reference 0, with level selected by PREFLVL and source selected by PREFSRC. 10: 1.25V (nominal) reference from the Reference Generator. 11: GPIO pin used as DAC output, DAC.
[1:0]	Positive Input Signal Select
INPSEL	00: GPIO pin used as Comparator 0 positive input, C0INP 01: Temperature sensor. 10: GPIO pin used as Op Amp B output, AMPBOUT. 11: Op Amp A output. This selection provides an internal connection that does not involve the GPIO used as Op Amp A output, AMPAOUT.

24.4.3. Comparator 0 Control 1 Register

The Comparator 0 Control 1 Register is shown in Table 259. It provides control for Comparator 0 and Programmable Reference 0.

Table 259. Comparator 0 Control 1 Register (CMP0CTL1)

Bit	7	6	5	4	3	2	1	0
Field	POLSEL	PREFEN	PREFSRC	PREFLVL				
Reset	0	0	0	0	0	1	0	1
R/W	R/W	R/W	R/W	R/W	R/W	R/W	R/W	R/W
Address	F91h							

Bit	Description
[7]	Polarity Select
POLSEL	0: Noninverted comparator output. The comparator output is High when the positive comparator input voltage is greater than the negative comparator input voltage. 1: Inverted comparator output. The comparator output is Low when the positive comparator input voltage is greater than the negative comparator input voltage.
[6]	Programmable Reference Enable
PREFEN	0: Programmable Reference disabled. The bandgap is selected as the comparator negative input if INNSEL=01. 1: Programmable Reference enabled as defined by PREFSRC and PREFLVL. The Programmable Reference level is selected as the comparator negative input if INNSEL=01.

Bit	Description (Continued)
[5] PREFSRC	Programmable Reference Source Selection 0: VBIAS is the highest tap of the Programmable Reference. 1: AV _{DD} is the highest tap of the Programmable Reference.
[4:0] PREFLVL	Programmable Reference Level Selection 00000 to 11111: Programmable reference level=(PREFSRC selection) * (PREFLVL + 1) ÷ 32.

24.4.4. Comparator 1 Control 0 Register

The Comparator 1 Control 0 Register is shown in Table 260.

Table 260. Comparator 1 Control 0 Register (CMP1CTL0)

Bit	7	6	5	4	3	2	1	0
Field	CPOWER		HYST		INNSEL		INPSEL	
Reset	0	0	0	0	0	0	0	0
R/W	R/W	R/W	R/W	R/W	R/W	R/W	R/W	R/W
Address	F92h							

Bit	Description
[7:6] CPOWER	Comparator Power/Speed Select 00: Ultra-low power, current=200nA, Tpd=10µs (nominal values). 01: Low power, current=1µA, Tpd=1.5µs (nominal values). 10: Normal, current=4µA, Tpd=700ns (nominal values). 11: High Speed/Power, current=27µA, Tpd=150ns (nominal values).
[5:4] HYST	Hysteresis Level Select 00 None, 0mV. 01: 15mV (nominal). 10: Reserved. 11: 40mv (nominal).

Bit	Description (Continued)
[3:2]	Negative Input Signal Select
INNSEL	00: GPIO pin used as Comparator 1 negative input, C1INN. 01: If PREFEN=0, bandgap reference from the Reference Generator. If PREFEN=1, Programmable Reference 1, with level selected by PREFLVL and source selected by PREFSRC. 10: 0.75V (nominal) reference from the Reference Generator. 11: GPIO pin used as DAC output, DAC.
[1:0]	Positive Input Signal Select
INPSEL	00: GPIO pin used as Comparator 1 positive input, C1INP. 01: Temperature sensor. 10: GPIO pin used as Op Amp B output, AMPBOUT. 11: Op Amp A output. This selection provides an internal connection that does not involve AMPAOUT, which is the GPIO used as the Op Amp A output.

24.4.5. Comparator 1 Control 1 Register

The Comparator 1 Control 1 Register is shown in Table 261. It provides control for Comparator 1 and Programmable Reference 1.

Table 261. Comparator 1 Control 1 Register (CMP1CTL1)

Bit	7	6	5	4	3	2	1	0
Field	POLSEL	PREFEN	PREFSRC	PREFLVL				
Reset	0	0	0	0	0	0	1	1
R/W	R/W	R/W	R/W	R/W	R/W	R/W	R/W	R/W
Address	F93h							

Bit	Description
[7]	Polarity Select
POLSEL	0: Noninverted comparator output. The comparator output is High when the positive comparator input voltage is greater than the negative comparator input voltage. 1: Inverted comparator output. The comparator output is Low when the positive comparator input voltage is greater than the negative comparator input voltage.
[6]	Programmable Reference Enable
PREFEN	0: Programmable reference disabled. Bandgap is selected as the comparator negative input if INNSEL=01. 1: Programmable reference enabled as defined by PREFSRC and PREFLVL. The Programmable reference level is selected as the comparator negative input if INNSEL=01.



Bit	Description (Continued)
[5] PREFSRC	Programmable Reference Source Selection 0: VBIAS is the highest tap of the Programmable Reference. 1: AV _{DD} is the highest tap of the Programmable Reference.
[4:0] PREFLVL	Programmable Reference Level Selection 00000 to 11111: Programmable reference level = (PREFSRC selection) * (PREFLVL + 1) ÷ 32.

Chapter 25. Temperature Sensor

The on-chip Temperature Sensor allows temperature measurement on the die to an accuracy of $\pm 4^{\circ}\text{C}$ over a range of -40°C to $+85^{\circ}\text{C}$. Over a reduced range, the accuracy is $\pm 1.5^{\circ}\text{C}$. This block is a moderately accurate temperature sensor for low-power applications in which high accuracy is not required. The Temperature Sensor offers the following features:

- On-chip temperature sensor
- $\pm 4^{\circ}\text{C}$ full-range accuracy for calibrated version
- $\pm 1.5^{\circ}\text{C}$ accuracy over the range of 20°C to 30°C
- Temperature sensor output available to the ADC and comparators

25.1. Operation

The on-chip Temperature Sensor is a Proportional To Absolute Temperature (PTAT) topology. The temperature sensor can be disabled by a bit in the [Power Control Register 0](#) (see page 52) to reduce power consumption.

The Temperature Sensor can be directly read by the ADC to determine the absolute value of its output. The temperature sensor output is also available as an input to the comparator for threshold-type measurement determination. The accuracy of the sensor when used with the comparator is less than when measured by the ADC. To learn more about selecting the Temperature Sensor as an ADC input, see the [Analog-to-Digital Converter](#) chapter on page 439. For details about selecting the Temperature Sensor as a Comparator input, see the [Comparators and Reference System](#) chapter on page 486.

During normal operation, the die undergoes heating that will cause a mismatch between the ambient temperature and that measured by the sensor. For best results, the F6482 Series device should be placed into Stop Mode for sufficient period such that the die and ambient temperatures converge (this period will be dependent on the thermal design of the system). The Temperature Sensor should be measured immediately after recovery from Stop Mode. The Temperature Sensor can remain active during Stop Mode to minimize the latency between Stop-Mode Recovery and performing a temperature measurement.

The following equation defines the relationship between the Temperature Sensor voltage and the die temperature.

$$V_{\text{TS}} = (T + 273) * 0.003272\text{V}/^{\circ}\text{C} - 0.025\text{V}$$

In this equation, V_{TS} is the Temperature Sensor output in volts and T is the temperature in $^{\circ}\text{C}$.

The following equation defines the relationship between the die temperature and the Temperature Sensor voltage.

$$T = ((V_{TS} + 0.025) / 0.003272) - 273$$

$$T = (V_{TS} - 0.868V) \div 0.003272V/^{\circ}C$$

In this equation, V_{TS} is the Temperature Sensor output in volts and T is the temperature in $^{\circ}C$.

The following equation defines the relationship between the 12-bit ADC output code and the die temperature.

$$ADC_{OUTPUT} = ((T + 273) * 0.003272V/^{\circ}C - 0.025V) \div V_{REF} * 4095$$

In this equation, ADC_{OUTPUT} is the 12-bit ADC output code, T is the temperature in $^{\circ}C$, and V_{REF} is the ADC voltage reference value in volts.

ADC output values for temperature sensor conversions with a 1.25V ADC voltage reference are shown in Table 262.

Table 262. Temperature vs. ADC Output, ADC $V_{REF} = 1.25V$

Temperature $^{\circ}C$	V_{TEMP}	ADC Output (Hex)
-40	0.737	96F
-35	0.754	9A5
-30	0.770	9DA
-25	0.786	A10
-20	0.803	A46
-15	0.819	A7B
-10	0.836	AB1
-5	0.852	AE6
0	0.868	B1C
+5	0.885	B52
+10	0.901	B87
+15	0.917	BBD
+20	0.934	BF2
+25	0.950	C28
+30	0.966	C5D
+35	0.983	C93
+40	0.999	CC9
+45	1.015	CFE
+50	1.032	D34

Table 262. Temperature vs. ADC Output, ADC $V_{REF} = 1.25V$ (Continued)

Temperature °C	V_{TEMP}	ADC Output (Hex)
+55	1.048	D69
+60	1.065	D9F
+65	1.081	DD5
+70	1.097	E0A
+75	1.114	E40
+80	1.130	E75
+85	1.146	EAB

25.1.1. Calibration

The Temperature Sensor undergoes calibration during the manufacturing process and is maximally accurate at 30°C. Accuracy decreases as measured temperatures move further from the calibration point.

Chapter 26. Liquid Crystal Display Controller

The Z8 Encore! Liquid Crystal Display (LCD) Controller contains dual data memory banks and provides low-power bias generation, waveform generation, and drives the liquid crystal display. The LCD Controller offers the following features:

- Directly drives 3 V LCDs
- Up to 4 common lines and 24 segment lines
- Compatible with static, 1/2, 1/3, 1/4 duty shows operating at full, 1/2, 1/3 bias
- Selectable Type A or Type B LCD waveform generation
- Dual memory banks and blinking modes
- Frame rate interrupt (every two frames for Type B) or blink rate interrupt
 - The frame rate (or blink rate) dividers can be used as a timer even if LCD waveforms are not being generated
- Can be selected to remain active in Stop Mode
- V_{LCD} is selectable as either the internal regulated charge pump (2.5 V to 3.5 V), V_{DD} , or external supply
- Two contrast control methods are provided:
 - Programmable charge pump voltage
 - Dead time insertion for both internal V_{DD} and external V_{LCD}

26.1. Architecture

The LCD Controller is comprised of two display memory banks, clock dividers, a charge pump, a bias generator, and a waveform generator. The clock dividers include a prescaler, a frame rate divider, and a blink rate divider. The architecture of the LCD Controller is shown in Figure 85.

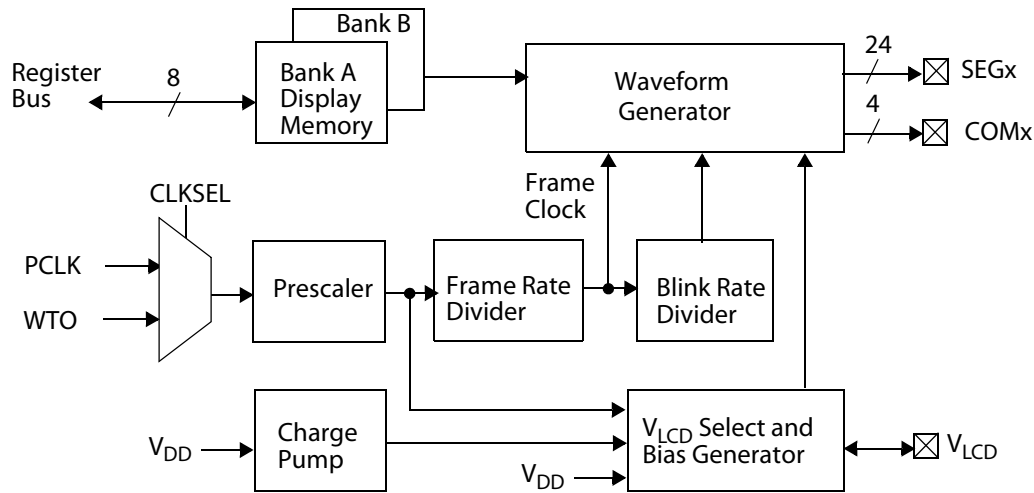

Figure 85. Liquid Crystal Display Controller Block Diagram

26.2. Operation

The LCD Controller accesses data from the selected LCD display memory bank and generates LCD waveforms using selected biases to directly drive an external LCD. Timing for the waveform generation is flexible, and depends on the selected configuration of the prescaler and the frame rate divider. Display blinking is supported using the blink rate divider. Biasing of the LCD outputs is also flexible, and allows the LCD voltage supply (V_{LCD}) to be supplied by an internal charge pump, V_{DD} , or an external voltage reference.

Two methods of contrast control are provided. When using the internal charge pump, the V_{LCD} generated is programmable, thereby providing contrast control. When using V_{DD} or an external V_{LCD} supply, a selectable number of dead cycles can be inserted into the frames to provide contrast control. See the [Contrast Control](#) section on page 518 to learn more.

The LCD Controller supports both Type A and Type B waveform generation, as described in the [Waveform Generation](#) section on page 510. For Type A waveforms, the common signals repeat each LCD frame. For Type B waveforms, the common signals repeat after every two LCD frames.

The LCD Controller is enabled by setting LCD in the PWRCTL0 Register, as described in the [Low-Power Modes](#) chapter on page 50. The following sections describe the operation of the LCD Controller.

26.2.1. LCD Registers and Subregisters

Five registers configure the LCD Controller, and two registers provide access to the LCD Display Memory Bank A and Bank B subregisters. The LCD Subaddress Register (LCDSA) and an LCD Subdata Register (LCDSD) together provide access to the 12 subregisters of each bank of LCD display memory – namely, the LCDMEMAx and LCDMEMBx subregisters. LCDSD provides a portal to these subregisters.

For convenient access, the address in the LCDSA Register autoincrements modulo 12 with each LCDSD read or write to provide convenient access to LCD data memory subregisters without intervening writes to the LCDSA Register. To use autoincrementing when loading LCD display memory, software typically configures the starting address in the LCDSA Register to be 00h (Bank A) or 10h (Bank B), and must write the LCDSD values in order. When the autoincremented value of LCDSA reaches 0Bh (Bank A), the next access to the LCDSD Register will reset LCDSA to 00h. When the autoincremented value of LCDSA reaches 1Bh (Bank B), the next access to the LCDSD Register will reset LCDSA to 10h.

To maintain an average zero DC bias for the LCD segments, changes in the control registers take effect at the end of the waveform generator frame pattern.

26.2.2. LCD Display Memory

The following sections describe the LCD display memory.

26.2.2.1. LCD Display Memory Banks A and B

Two banks of LCD display memory, Bank A and Bank B, are provided; each bank consists of 12 bytes of display data. As described in the [LCD Registers and Subregisters](#) section on page 505, the LCD Subaddress Register (LCDSA) and a LCD Subdata Register (LCDSD) together provide access to subregisters in the LCD Display Memory Bank A and Bank B; i.e., the LCDMEMAx and LCDMEMBx subregisters.

At any given time, only one LCD display memory bank is selected as the data source for the LCD; this bank can be selected with the DMMODE bit in the LCDCTL2 Register. Two additional DMMODE selections are available: *alternating between banks* and *blanking the display*. The bank currently selected as the source for the LCD Controller output is indicated by the MSTAT bit in the LCDCTL2 Register. Alternating between display memory banks can be used to perform blinking with timing set by the blink rate control, as described in the [LCD Blinking and Blanking](#) section on page 508.

26.2.2.2. Writing the Display Memory

When using Type A LCD waveforms, a display memory bank that is currently selected as the source for the waveform generator can be written any time without causing a DC voltage on LCD segments. When using Type B LCD waveforms, a display memory bank that is currently selected as the source for the waveform generator should be written just prior to the frame boundary of the alternate frame to avoid an average nonzero DC voltage on the LCD display segments. If the IRQS bit is cleared in the LCDCTL2 Register, LCD

frame interrupts are generated that are synchronized to display memory updates, as described in the [LCD Control 2 Register](#) section on page 526.

Alternatively, LCD Display Memory Bank A and Bank B can be used to provide buffered LCD display memory updates asynchronous to the LCD interrupt and waveform generator. With this alternate usage, one LCD display memory bank is the data source to the waveform generator, while the other LCD display memory bank is updated.

26.2.2.3. Display Memory Organization

Table 263 shows how the LCD display memory is organized.

Table 263. LCD Display Memory Organization

Subaddress in LCDSA*	Bit in LCDMEMAx, LCDMEMBx Subregisters							
	7	6	5	4	3	2	1	0
LCDMEMAx	COM3	COM2	COM1	COM0	COM3	COM2	COM1	COM0
0Bh		SEG23				SEG22		
0Ah		SEG21				SEG20		
09h		SEG19				SEG18		
08h		SEG17				SEG16		
07h		SEG15				SEG14		
06h		SEG13				SEG12		
05h		SEG11				SEG10		
04h		SEG09				SEG08		
03h		SEG07				SEG06		
02h		SEG05				SEG04		
01h		SEG03				SEG02		
00h		SEG01				SEG00		
LCDMEMBx	COM3	COM2	COM1	COM0	COM3	COM2	COM1	COM0
1Bh		SEG23				SEG22		
1Ah		SEG21				SEG20		
19h		SEG19				SEG18		
18h		SEG17				SEG16		
17h		SEG15				SEG14		
16h		SEG13				SEG12		
15h		SEG11				SEG10		
14h		SEG09				SEG08		
13h		SEG07				SEG06		

Note: *LCDSA in the LCDSA Register contains the subregister address.

Table 263. LCD Display Memory Organization (Continued)

Subaddress in LCDSA*	Bit in LCDMEMAx, LCDMEMBx Subregisters							
	7	6	5	4	3	2	1	0
LCDMEMAx	COM3	COM2	COM1	COM0	COM3	COM2	COM1	COM0
12h		SEG05				SEG04		
11h		SEG03				SEG02		
10h		SEG01				SEG00		

Note: *LCDSA in the LCDSA Register contains the subregister address.

26.2.3. LCD Frame Timing

The LCD frame timing is a function of the LCD Controller clock selection, prescaler divide ratio, frame rate divide ratio, duty and contrast control. The LCD Controller clock selection, prescaler divide ratio, and frame rate divide ratio are configured in the LCD-CLK Register. Either PCLK or the WTO can be selected as the LCD Controller input clock source using the CLKSEL bit. The prescaler divide ratio is selected using the PRESCALE bit, and the prescaler output clocks the frame rate divider and dynamic bias generator, as described in the [Bias Generator Selection](#) section on page 509. The frame rate divide ratio is selected using the FDIV bit, and results in the frame clock.

Duty, bias, and waveform type are configured with the LCDMODE bit in the LCD Control 2 Register (LCDCTL2). Contrast control is configured with CONTRAST in the LCD Control 1 Register (LCDCTL1), which selects the number of dead frame clock cycles per frame (Type A waveforms) or per frame pair (Type B waveforms). See the [Waveform Generation](#) section on page 510 and the [Contrast Control](#) section on page 518 to learn more.

For static, 1/2 and 1/4 duty:

$$\text{Frame rate} = (\text{LCD Controller input clock frequency}) \div ((8 + \text{DEAD CYCLES}) * \text{PRESCALE} * \text{FDIV})$$

In this equation, DEAD CYCLES is selected by the value of CONTRAST.

For 1/3 duty:

$$\text{Frame rate} = (\text{LCD Controller input clock frequency}) \div ((6 + \text{DEAD CYCLES}) * \text{PRESCALE} * \text{FDIV})$$

In this equation, DEAD CYCLES is selected by the value of CONTRAST.

For Type A waveforms, the common signals (COMx) repeat each LCD frame, whereas for Type B waveforms, the common signals repeat after every two LCD frames.

As an example, the configuration that follows results in a frame rate that corresponds to the following equation:

$$32.768\text{kHz} \div ((8 + 2) * 4 * 20) = 41\text{Hz}$$

- CLKSEL=0 (PCLK @ 32.768kHz)
- PRESCALE=010 (divide by 4)
- FDIV=1001 (divide by 20)
- LCDMODE= 1001, 1010, 1011, or 1100 (1/4 duty)
- CPEN=0 (internal charge pump off)
- CONTRAST=010 (2 dead cycles if CPEN=0)

26.2.4. LCD Blinking and Blanking

Blinking can be performed using a single LCD display memory bank or using both LCD display memory banks. In either case, the blinking rate is controlled by BDIV in the LCD Control 0 Register (LCDCTL0). The blink rate is determined as follows:

$$\text{Blink rate} = (\text{frame rate}) \div (4 * \text{BDIV})$$

When using a single display memory bank, the blinking mode is configured using BMODE. When BMODE=00, no blinking occurs; otherwise, blinking will occur on the display segment accessed by SEG0 and COM0 (BMODE=01), the 4 display segments accessed by SEG0 and COM[3:0] (BMODE=10), or on all segments (BMODE=11).

Alternating between display memory banks A and B can be employed to perform blinking. To enable the ability to alternate between display memory banks, configure DMMODE=10 in the LCD Control 2 Register. When DMMODE=10, BMODE has no effect upon operation.

To blank the display, configure DMMODE=11 in the LCD Control 2 Register (LCDCTL2). Blanking the display in this way does not alter LCD display memory. When DMMODE=11, BMODE has no effect upon operation.

26.2.5. Using the LCD as a Timer

The prescaler, frame rate divider, and blinking divider can be used as a timer even if LCD waveforms are not being generated. To use the LCD as a timer without LCD waveform generation, configure the prescaler and dividers, as described in the [LCD Frame Timing](#) section on page 507 and the [LCD Blinking and Blanking](#) section on page 508; clear the WGENEN bit in the LCDCTL3 Register, and set the LCD bit in the PWRCTL0 Register. Interrupts are generated, as described in the [Interrupts](#) section on page 519.

26.2.6. LCD Voltage and Bias Generation

The following sections describe LCD voltage and bias generation. A corresponding block diagram is shown in Figure 86.

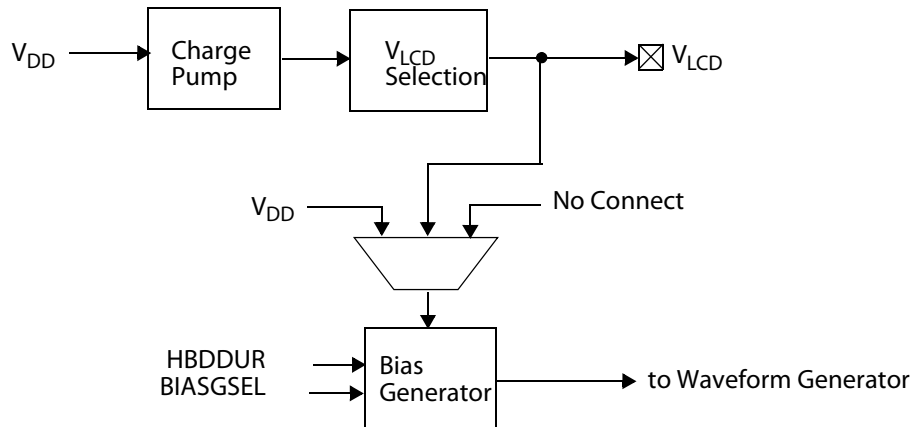

Figure 86. LCD Voltage and Bias Generation Block Diagram

26.2.6.1. Internal Charge Pump

The internal charge pump is enabled by setting the CPEN bit in the LCDCTL1 Register. Two provided charge-pumping options, *voltage doubler* and *voltage tripler*, are selected using the CPTSEL bit in the LCDCTL3 Register. At lower V_{DD} levels, the voltage tripler (CPTSEL=0) provides higher maximum V_{LCD} output levels than the voltage doubler (CPTSEL=1), but at the expense of higher current consumption; see the [Electrical Characteristics](#) chapter on page 601 to learn more. In addition, the internal charge pump output current is a function of the BIASGSEL bit, as described in the [Bias Generator Selection](#) section on page 509.

When using the internal charge pump, the V_{LCD} output voltage is selectable, thereby providing contrast control, as described in the [Contrast Control](#) section on page 518.

26.2.6.2. Bias Generator Selection

For modes other than Static Mode, V_{LCD} is internally divided with a 4.5M Ω resistive network to produce a low bias drive at the selected bias levels. At waveform transitions, the drive of these bias levels can be selected to increase temporarily to speed settling before reverting to the low drive biasing to sustain the output levels at lower current consumption. Two selectable higher transition bias drives, normal (nominally 360k Ω for 1/3 LCD waveform biasing and 240k Ω for 1/2 LCD waveform biasing) or high (nominally 90k Ω for 1/3 LCD waveform biasing and 60k Ω for 1/2 LCD waveform biasing), allow matching of bias generator current consumption to LCD capacitive load, and are selected using the

BIASGSEL bit in the LCDCTL1 Register. When the high transition bias drive is selected (BIASGSEL=1), the internal charge pump output current capacity is also increased.

The high drive biasing duration is selected using the HBDDUR bit in the LCDCTL1 Register. See the [Electrical Characteristics](#) chapter on page 601 to learn more about bias generator current consumption and the bias drive.

26.2.6.3. V_{LCD} and Bias Generator Source Selection

LCD bias generator source options include the internal charge pump, V_{DD} connected internally, and an external supply. As shown in Table 264, V_{LCD} source selection is determined by the CPEN bit in the LCDCTL1 Register and the VLCDDIR bit in the LCDCTL3 Register. When the LCD Controller is disabled by clearing the LCD bit in the PWRCTL0 Register, V_{LCD} is not driven, and no bias generator sources are connected to the bias generator.

Table 264. V_{LCD} and Bias Generator Source Selection

Control Settings			Selected Functionality		
LCD (PWRCTL0)	VLCDDIR (LCDCTL3)	CPEN (LCDCTL1)	V_{LCD} Connection	Bias Generator Source	Charge Pump State
1	1	0	No connect	V_{DD}	OFF
1	1	1	Bias generator & internal charge pump	Internal charge pump	ON
1	0	0	Bias generator & external supply	External supply	OFF
1	0	1	Bias generator*	No connect	OFF
0	x	x	No connect	No connect	OFF

Note: *Typically not selected, because the bias generator resistive network will discharge V_{LCD} .

26.2.7. LCD Outputs

Selecting LCD Controller outputs to drive the GPIO pins is a GPIO alternate function selection. See the [General-Purpose Input/Output](#) chapter on page 55 to learn more about selecting LCD outputs.

26.2.8. Waveform Generation

To enable waveform generation, set the WGENEN bit in the LCDCTL3 Register. The following sections describe waveform generation. The waveform characteristics, as summarized in Table 265, are selected with the LCDMODE bit in the LCTCTL2 Register.

Table 265. LCD Mode Selection and Corresponding Waveform Characteristics

LCDMODE (LCDCTL2)	# Commons	Duty	Bias	Waveform Type
0000	1	1	Static	Static
0001	2	1/2	1/2	A
0010	2	1/2	1/2	B
0011	2	1/2	1/3	A
0100	2	1/2	1/3	B
0101	3	1/3	1/2	A
0110	3	1/3	1/2	B
0111	3	1/3	1/3	A
1000	3	1/3	1/3	B
1001	4	1/4	1/2	A
1010	4	1/4	1/2	B
1011	4	1/4	1/3	A
1100	4	1/4	1/3	B
Others		Reserved		

26.2.8.1. Static Mode

Static Mode is selected by configuring LCDMODE=0000 in the LCDCTL2 Register. In this mode, only COM0 is used, and each SEGx drives one LCD display segment. Example waveforms for Static Mode are shown in Figure 87.

Memory Map Example									
COM3	COM2	COM1	COM0		COM3	COM2	COM1	COM0	
x	x	x	0	SEG01	x	x	x	1	SEG00

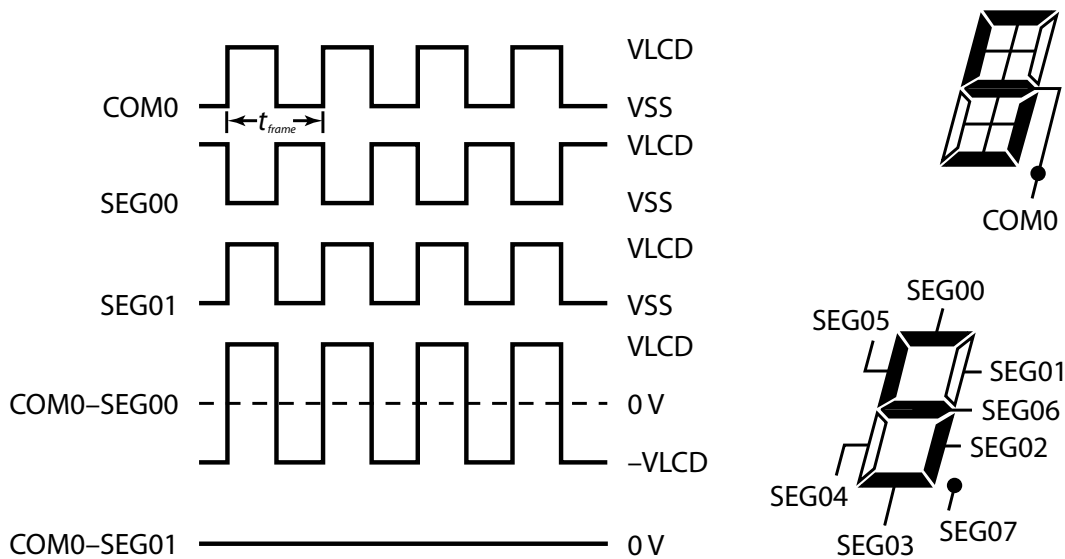

Figure 87. Static Mode Example Waveforms

26.2.8.2. 1/2 Duty Mode

1/2 Duty Mode configurations are shown in Table 265 and are selected with the LCD-MODE bit in the LCDCTL2 Register. In this mode, only COM[1:0] are used, and each SEG_x drives up to two LCD display segments. Example waveforms for 1/2 Duty Mode with 1/2 bias are shown in Figure 88 (Type A) and Figure 89 (Type B).

Memory Map Example									
COM3	COM2	COM1	COM0		COM3	COM2	COM1	COM0	
x	x	0	1	SEG01	x	x	1	1	SEG00

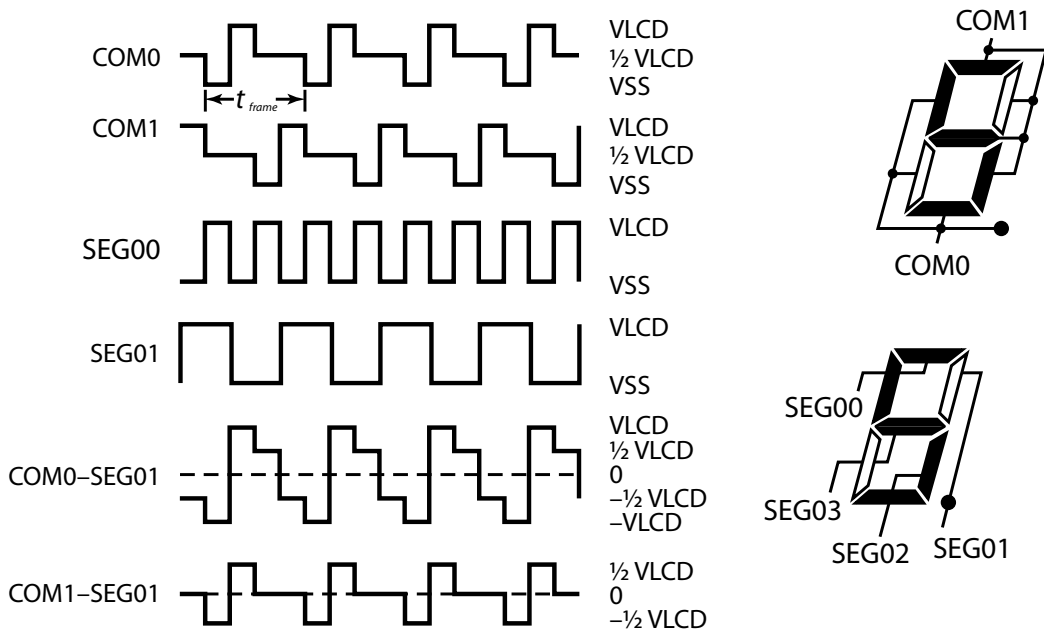

Figure 88. 1/2 Duty Mode with 1/2 Bias Type A Example Waveforms

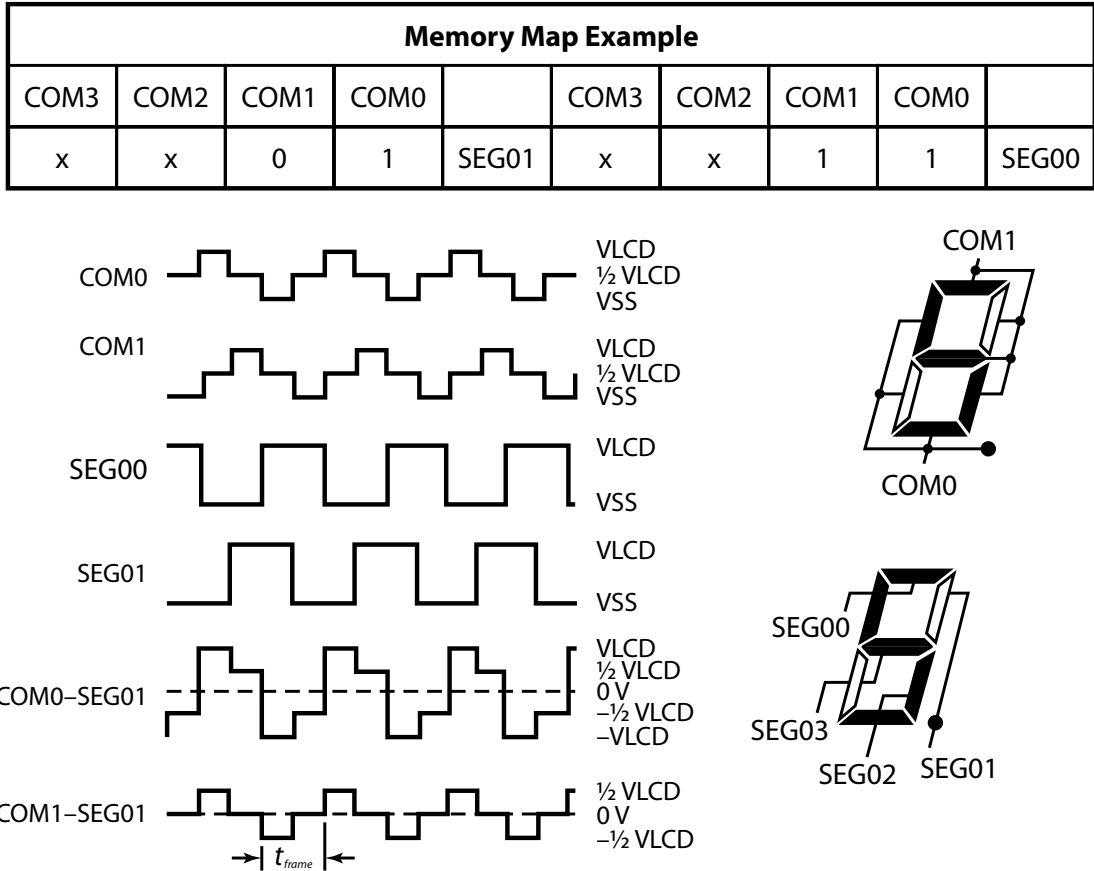

Figure 89. 1/2 Duty Mode with 1/2 Bias Type B Example Waveforms

26.2.8.3. 1/3 Duty Mode

1/3 Duty Mode configurations are shown in [Table 265](#) on page 511 and are selected with the LCDMODE bit in the LCDCTL2 Register. In this mode, only COM[2:0] are used, and each SEGx drives up to three LCD display segments. Example waveforms for 1/3 Duty Mode with 1/3 bias are shown in Figure 90 (Type A) and Figure 91 (Type B).

Memory Map Example									
COM3	COM2	COM1	COM0		COM3	COM2	COM1	COM0	
					x	0	1	1	SEG02
x	1	1	1	SEG01	x	x	1	0	SEG00

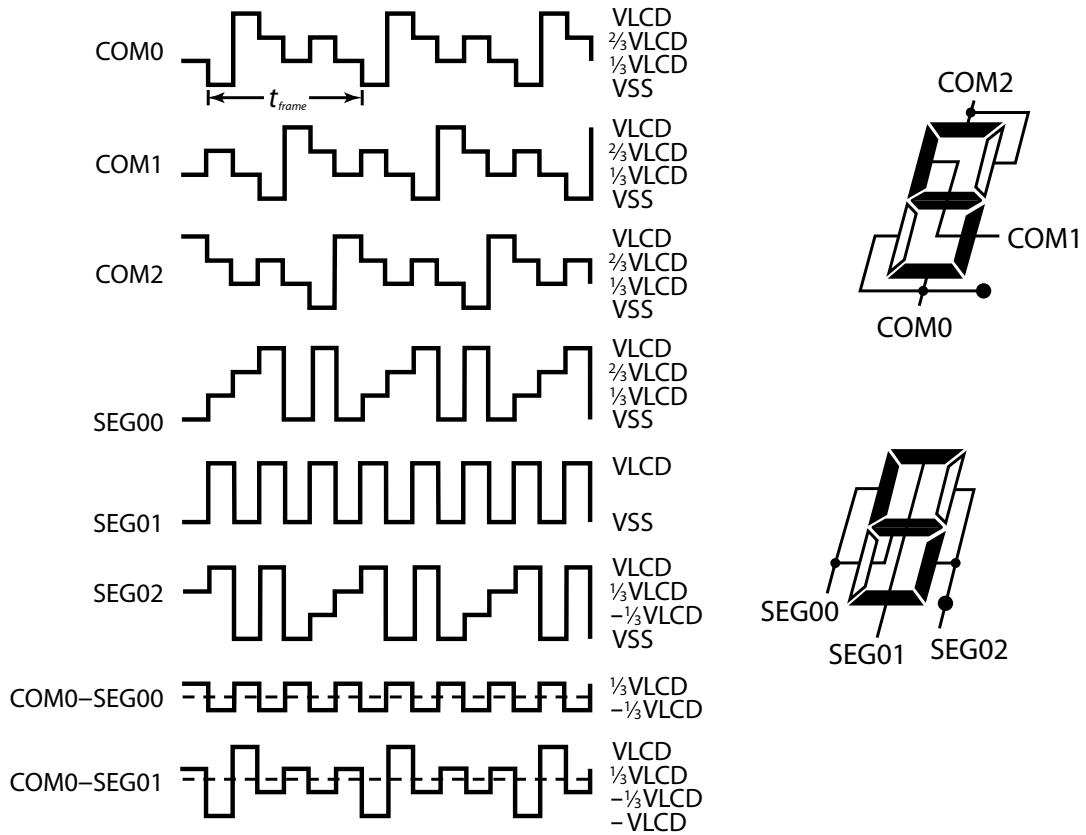

Figure 90. 1/3 Duty Mode with 1/3 Bias Type A Example Waveforms

Memory Map Example									
COM3	COM2	COM1	COM0		COM3	COM2	COM1	COM0	
					x	0	1	1	SEG02
x	1	1	1	SEG01	x	x	1	0	SEG00

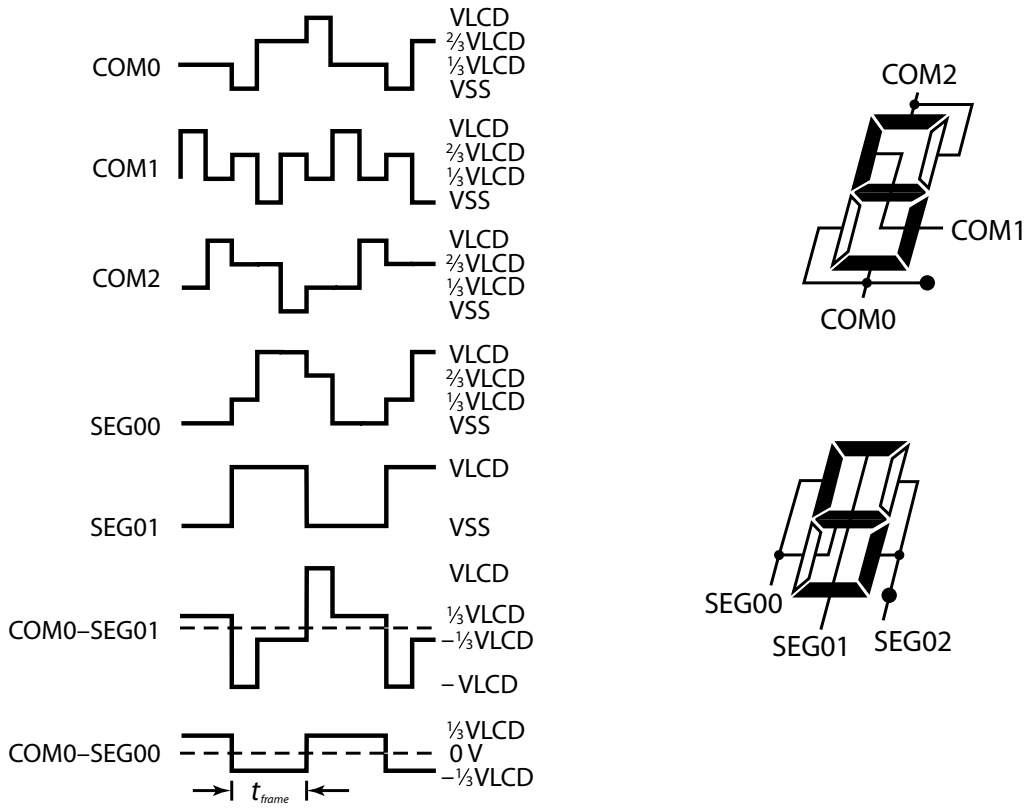

Figure 91. 1/3 Duty Mode with 1/3 Bias Type B Example Waveforms

26.2.8.4. 1/4 Duty Mode

1/4 Duty Mode configurations are shown in [Table 265](#) on page 511, and are selected with the LCDMODE bit in the LCDCTL2 Register. In this mode, all commons (COM[3:0]) are used, and each SEGx drives up to four LCD display segments. Example waveforms for 1/4 Duty Mode with 1/3 bias are shown in Figure 92 (Type A) and Figure 93 (Type B).

Memory Map Example									
COM3	COM2	COM1	COM0		COM3	COM2	COM1	COM0	
1	0	1	1	SEG01	1	1	0	1	SEG00

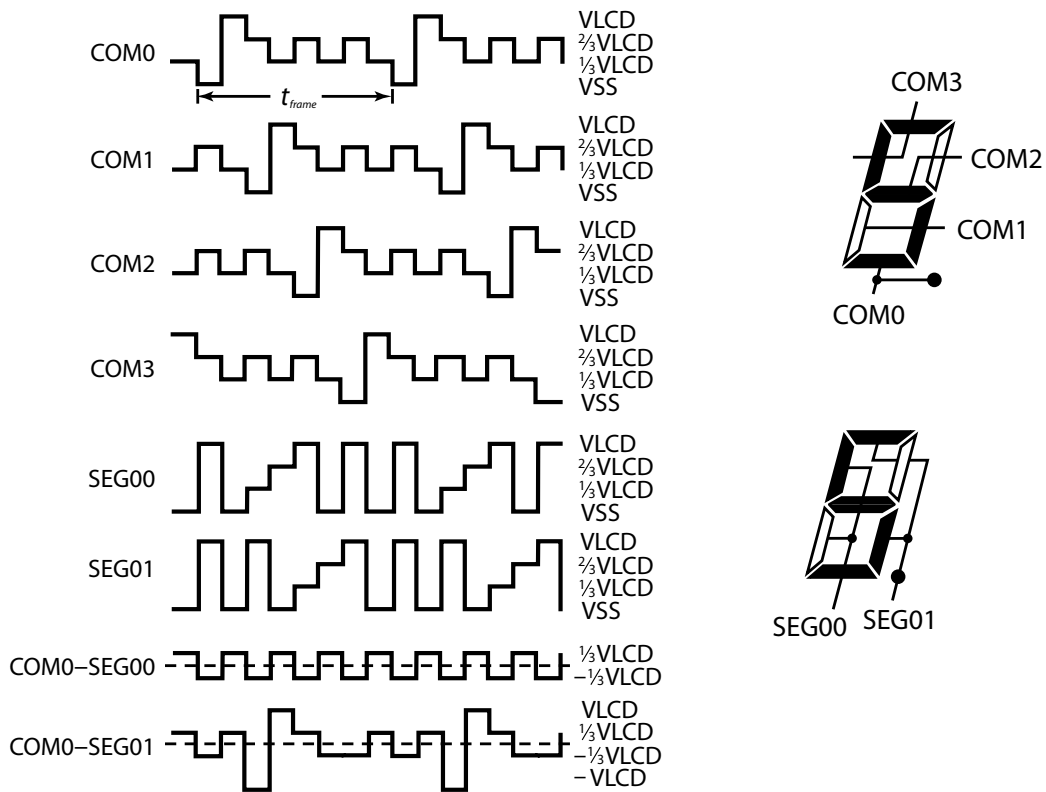

Figure 92. 1/4 Duty Mode with 1/3 Bias Type A Example Waveforms

Memory Map Example									
COM3	COM2	COM1	COM0		COM3	COM2	COM1	COM0	
1	0	1	1	SEG01	1	1	0	1	SEG00

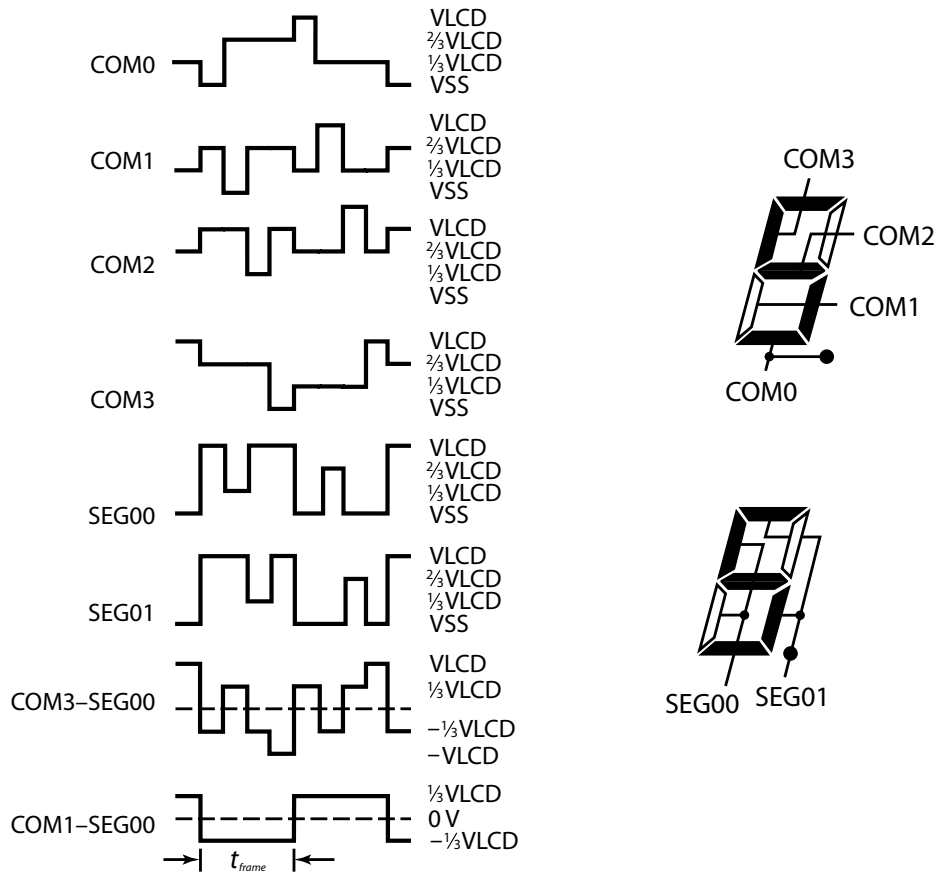

Figure 93. 1/4 Duty Mode with 1/3 Bias Type B Example Waveforms

26.2.9. Contrast Control

Two methods of contrast control are provided. When using the internal charge pump to generate V_{LCD} , the generated V_{LCD} level is programmable using the CONTRAST bit in the LCDCTL1 Register to provide contrast control. When using V_{DD} or an external V_{LCD} supply, a selectable number of dead cycles can be inserted into the frames to provide contrast control using this CONTRAST bit.

26.2.10. Stop Mode Operation

The LCD Controller is able to operate during Stop Mode. If LCD Controller operation is not desired during Stop Mode, clear the LCD bit in the PWRCTL1 Register prior to entering Stop Mode. When the LCD bit is cleared, the LCD Controller remains operating until the current frame is completed.

26.2.11. Interrupts

Interrupt generation is selectable to occur either at the end of a frame or at a blink, and is selected with the IRQS bit in the LCDCTL2 Register. When blinking (BMODE=01, 10, 11), the interrupt occurs at the start of the blink. When alternating between LCD display memory banks A and B (DMMODE=10), the interrupt occurs when the current data source for the LCD display output switches from LCD Display Memory Bank A to LCD Display Memory Bank B.

26.3. LCD Control Register Definitions

Five registers provide access to LCD Controller clocking and control, and two additional registers provide access to the LCD Display Memory Bank A and B subregisters.

Table 266 lists these LCD Controller registers and subregisters. To maintain average zero DC bias for the LCD display segments, changes in the LCD control registers take effect at the end of the waveform generator frame pattern.

The LCD Subaddress Register (LCDSA) and LCD Subdata Register (LCDSB) together provide access to the subregisters for LCD Display Memory Bank A and B. LCDSB provides a portal to the these LCD display memory bank subregisters.

Table 266. LCD Controller Registers and Subregisters

LCD Register Mnemonic	Address	LCD Register Name
LCDSA	FB1h	LCD Subaddress Register
LCDSB	FB2h	LCD Subdata Register
LCDCLK	FB3h	LCD Clock Register
LCDCTL0	FB4h	LCD Control 0 Register
LCDCTL1	FB5h	LCD Control 1 Register
LCDCTL2	FB6h	LCD Control 2 Register
LCDCTL3	FB7h	LCD Control 3 Register
LCD Subregister Mnemonic	Subregister Address*	LCD Subregister Name
LCDMEMAx	00–0Bh	LCD Display Memory Bank A 0–11
LCDMEMBx	10–1Bh	LCD Display Memory Bank B 0–11

Note: * LCDSA in the LCDSA Register contains the subregister address.

26.3.1. LCD Subaddress Register

The LCD Subaddress Register shown in Table 267 selects the LCD functionality accessible through the LCD Subdata Register. The LCD Subaddress and LCD Subdata registers combine to provide access to all LCD display memory.

The LCDSA bits in the LCDSA Register are autoincremented whenever LCDSD is accessed (read or written) to provide convenient access to LCD data memory subregisters without intervening writes to the LCDSA Register. To take advantage of autoincrementing, software must write the LCDSD values in order, typically starting from address 00h. When the autoincremented value of LCDSA reaches 0Bh, the next access to the LCDSD Register will reset LCDSA to 0. When the autoincremented value of LCDSA reaches 1Bh, the next access to the LCDSD Register will reset LCDSA to 10h.

Table 267. LCD Subaddress Register (LCDSA)

Bits	7	6	5	4	3	2	1	0
Field	Reserved			LCDSA				
Reset	0	0	0	0	0	0	0	0
R/W	R	R	R	R/W	R/W	R/W	R/W	R/W
Address	FB1h							

Bit	Description
[7:5]	Reserved These bits are reserved and must be programmed to 000.
[4:0] LCDSA	LCD Subaddress 00–0B: Selects the LCD Display Memory Bank A subregister accessed by the LCDSD access. LCDSA increments modulo 12 whenever LCDSD is read or written. 0C–0F: Reserved. 10–1B: Selects the LCD Display Memory Bank B subregister accessed by the LCDSD access. LCDSA increments modulo 12 whenever LCDSD is read or written. 1C–1F: Reserved.

26.3.2. LCD Subdata Register

The LCD Subdata Register, shown in Table 268, accesses the LCD display memory. The values in the LCDSA bits of the LCD Subaddress Register determine which LCD subregister is read from or written to by an access of the LCD Subdata Register. Whenever this access occurs, the LCDSA bits are incremented, as described in the LCD Subaddress Register.

Table 268. LCD Subdata Register (LCDSD)

Bits	7	6	5	4	3	2	1	0
Field	LCDSD							
Reset	0	0	0	0	0	0	0	0
R/W	R/W	R/W	R/W	R/W	R/W	R/W	R/W	R/W
Address	FB2h							

Bit	Description
[7:0]	LCD Subdata
LCDSD	00–FF: LCDSD is a portal providing access to all LCD display memory subregisters, as selected by LCDSA.

26.3.3. LCD Clock Register

The LCD Clock Register, shown in Table 269, controls the clocking of the LCD including: clock selection, clock prescale division and frame clock division.

Table 269. LCD Clock Register (LCDCLK)

Bits	7	6	5	4	3	2	1	0
Field	CLKSEL	PRESCALE			FDIV			
Reset	0	0	0	0	0	0	0	0
R/W	R/W	R/W	R/W	R/W	R/W	R/W	R/W	R/W
Address	FB3h							

Bit	Description
[7] CLKSEL	LCD Clock Selection 0: PCLK. 1: WTO.
[6:4] PRESCALE	LCD Clock Prescale Divider 000: Divide by 1. 001: Divide by 2. 010: Divide by 4. 011: Divide by 8. 100: Divide by 16. 101: Divide by 32. 110: Reserved. 111: Reserved.
[3:0] FDIV	Frame Divider 0000: Divide by 8. 0001: Divide by 9. 0010: Divide by 10. 0011: Divide by 11. 0100: Divide by 12. 0101: Divide by 13. 0110: Divide by 14. 0111: Divide by 16. 1000: Divide by 18. 1001: Divide by 20. 1010: Divide by 22. 1011: Divide by 24. 1100: Divide by 26. 1101: Divide by 28. 1110: Divide by 30. 1111: Divide by 32.



26.3.4. LCD Control 0 Register

The LCDCTL0 Register, shown in Table 270, controls blinking clock division and blinking mode. Writes to this register take effect at the end of the current waveform.

Table 270. LCD Control 0 Register (LCDCTL0)

Bits	7	6	5	4	3	2	1	0
Field	BDIV					BMODE		Reserved
Reset	0	0	0	0	0	0	0	0
R/W	R/W	R/W	R/W	R/W	R/W	R/W	R/W	R/W
Address	FB4h							

Bit	Description
[7:3] BDIV	Blinking Divider Ratio 00000: Divide by 2. 00001: Divide by 3. 00010: Divide by 4. 00011: Divide by 5. 00100: Divide by 6. 00101: Divide by 7. 00110: Divide by 8. 00111: Divide by 10. 01000: Divide by 12. 01001: Divide by 14. 01010: Divide by 16. 01011: Divide by 18. 01100: Divide by 20. 01101: Divide by 24. 01110: Divide by 28. 01111: Divide by 32. 10000: Divide by 34. 10001: Divide by 36. 10010: Divide by 38. 10011: Divide by 40. 10100: Divide by 42. 10101: Divide by 44. 10110: Divide by 46. 10111: Divide by 48. 11000: Divide by 50. 11001: Divide by 52. 11010: Divide by 54. 11011: Divide by 56. 11100: Divide by 58. 11101: Divide by 60. 11110: Divide by 62. 11111: Divide by 64.

Bit	Description (Continued)
[2:1] BMODE	<p>Blinking Mode BMODE has no effect if DMMODE = 1x.</p> <p>00: No Blinking. 01: One display segment blinks, the LCD display segment accessed by SEG0, COM0. 10: Up to 4 display segments blink, the LCD display segments accessed by SEG0, COM[3:0]. 11: All segments blink.</p>
[0]	<p>Reserved This bit is reserved and must be programmed to 0.</p>

26.3.5. LCD Control 1 Register

The LCDCTL1 Register, shown in Table 271, controls the internal charge pump and bias generators. Writes to this register take effect at the end of the current waveform.

Table 271. LCD Control 1 Register (LCDCTL1)

Bits	7	6	5	4	3	2	1	0
Field	HBDDUR			CPEN	BIASGSEL	CONTRAST		
Reset	0	0	0	0	0	0	0	0
R/W	R/W	R/W	R/W	R/W	R/W	R/W	R/W	R/W
Address	FB5h							

Bit	Description
[7:5] HBDDUR	<p>Higher Bias Drive Duration Determines the higher bias drive duration at waveform transitions. BIASGSEL selects the higher-bias drive for the waveform transition.</p> <p>000: Continuous low bias drive. 001: Higher bias drive for 1 prescaler output clock period, low bias drive otherwise. 010: Higher bias drive for 2 prescaler output clock periods, low bias drive otherwise. 011: Higher bias drive for 3 prescaler output clock periods, low bias drive otherwise. 100: Higher bias drive for 4 prescaler output clock periods, low bias drive otherwise. 101: Higher bias drive for 5 prescaler output clock periods, low bias drive otherwise. 110: Higher bias drive for 6 prescaler output clock periods, low bias drive otherwise. 111: Continuous higher bias drive. Supported only if CPEN=0 as the current consumption of the resistor network in continuous high bias drive exceeds the internal charge pump drive.</p>
[4] CPEN	<p>Charge Pump Enable 0: The internal LCD Controller charge pump is disabled. 1: The internal LCD Controller charge pump is enabled and is active in all operating modes including Stop Mode. The internal charge pump output current is selected with BIASGSEL.</p>

Bit	Description (Continued)
[3]	Bias Generator Selection
BIASGSEL	<p>0: The normal transition bias drive is selected, nominally 360kΩ for 1/3 LCD waveform biasing and 240kΩ for 1/2 LCD waveform biasing. Normal internal charge pump output current is also selected.</p> <p>1: The high transition bias drive is selected, nominally 90kΩ for 1/3 LCD waveform biasing and 60 kΩ for 1/2 LCD waveform biasing. High internal charge pump output current is also selected.</p>
[2:0]	Contrast Control
CONTRAST	<p>CONTRAST is a function of CPEN and waveform type (LCDMODE[2]).</p> <p>CPEN = 0, LCDMODE[2] = 0 (type B waveform): CONTRAST sets the number of frame clock cycles that all LCD Controller outputs are driven to V_{SS}.</p> <p>000: 0 dead cycles. 001: 1 dead cycles. 010: 2 dead cycles. 011: 3 dead cycles. 100: 4 dead cycles. 101: 6 dead cycles. 110: 8 for 1/2 and 1/4 duty. Reserved (not supported) for 1/3 duty. 111: Reserved.</p> <p>CPEN = 0, LCDMODE[2] = 1 (type A waveform): CONTRAST sets the number of frame clock cycles that all LCD Controller outputs are driven to V_{SS}.</p> <p>000: 0 dead cycles. 001: 1 dead cycles. 010: 2 dead cycles. 011: 3 dead cycles. 100: 4 dead cycles. 101: 5 dead cycles. 110: 6 dead cycles. 111: 8 for 1/2 and 1/4 duty. Reserved (not supported) for 1/3 duty.</p> <p>CPEN = 1: CONTRAST sets the V_{LCD} level generated by the internal charge pump.</p> <p>000: $V_{LCD} = 2.50V$ (nominal). 001: $V_{LCD} = 2.64V$ (nominal). 010: $V_{LCD} = 2.78V$ (nominal). 011: $V_{LCD} = 2.92V$ (nominal). 100: $V_{LCD} = 3.06V$ (nominal). 101: $V_{LCD} = 3.20V$ (nominal). 110: $V_{LCD} = 3.35V$ (nominal). 111: $V_{LCD} = 3.50V$ (nominal).</p>

26.3.6. LCD Control 2 Register

The LCDCTL2 Register, shown in Table 272, provides memory status and control, interrupt control and control of the LCD mode and waveform type. Writes to this register take effect at the end of the current waveform.

Table 272. LCD Control 2 Register (LCDCTL2)

Bits	7	6	5	4	3	2	1	0
Field	MSTAT	IRQS	LCDMODE				DMMODE	
Reset	0	0	0	0	0	0	0	0
R/W	R	R/W	R/W	R/W	R/W	R/W	R/W	R/W
Address	FB6h							

Bit	Description
[7] MSTAT	<p>LCD Memory Status</p> <p>0: LCD Display Memory Bank A is currently the source for the LCD Controller outputs. 1: LCD Display Memory Bank B is currently the source for the LCD Controller outputs.</p>
[6] IRQS	<p>Interrupt Request Select</p> <p>0: Frame interrupt. For static, 1/2, and 1/4 duty, the interrupt occurs at 7/8 frame for type A waveforms (LCDMODE[2]=1) and 7/4 frame for type B waveforms (LCDMODE[2]=0). For 1/3 duty, the interrupt occurs at 5/6 frame for type A waveforms (LCDMODE[2]=1) and 5/3 frame for type B waveforms (LCDMODE[2]=0).</p> <p>1: Blink Interrupt. When DMMODE=10, interrupt occurs when the LCD controller switches from LCD Memory Bank A to LCD Memory Bank B. When a blink mode is selected (BMODE = 01, 10, 11), interrupt occurs at the transition from displayed to blank.</p>
[5:2] LCDMODE	<p>LCD Operating Mode</p> <p>0000: 1 common (COM0), 1/1 duty, static bias, static waveform. 0001: 2 commons (COM[1:0]), 1/2 duty, 1/2 bias, type A waveform. 0010: 2 commons (COM[1:0]), 1/2 duty, 1/2 bias, type B waveform. 0011: 2 commons (COM[1:0]), 1/2 duty, 1/3 bias, type A waveform. 0100: 2 commons (COM[1:0]), 1/2 duty, 1/3 bias, type B waveform. 0101: 3 commons (COM[2:0]), 1/3 duty, 1/2 bias, type A waveform. 0110: 3 commons (COM[2:0]), 1/3 duty, 1/2 bias, type B waveform. 0111: 3 commons (COM[2:0]), 1/3 duty, 1/3 bias, type A waveform. 1000: 3 commons (COM[2:0]), 1/3 duty, 1/3 bias, type B waveform. 1001: 4 commons (COM[3:0]), 1/4 duty, 1/2 bias, type A waveform. 1010: 4 commons (COM[3:0]), 1/4 duty, 1/2 bias, type B waveform. 1011: 4 commons (COM[3:0]), 1/4 duty, 1/3 bias, type A waveform. 1100: 4 commons (COM[3:0]), 1/4 duty, 1/3 bias, type B waveform. Others: Reserved.</p>

Bit	Description (Continued)
[1:0]	Display Memory Mode
DMMODE	00: LCD Display Memory Bank A is the data source for LCD display output. Blinking is controlled by BMODE in the LCDCTL0 Register.
	01: LCD Display Memory Bank B is the data source for LCD display output. Blinking is controlled by BMODE in the LCDCTL0 Register.
	10: Alternate between LCD Display Memory Bank A and Bank B, controlled by blinking rate divider output. BMODE in the LCDCTL0 Register has no effect upon operation. Upon enable, Bank A will be selected first.
	11: Blank all segments. BMODE in the LCDCTL0 Register has no effect upon operation.

26.3.7. LCD Control 3 Register

The LCDCTL3 Register, shown in Table 273, controls the internal charge pump, V_{LCD} direction and waveform generation enable. Writes to this register take effect at the end of the current waveform.

Table 273. LCD Control 3 Register (LCDCTL3)

Bits	7	6	5	4	3	2	1	0
Field	Reserved	CPTSEL	VLCDDIR	WGENEN	Reserved			
Reset	0	0	0	0	0	0	0	0
R/W	R	R/W	R/W	R/W	R	R	R	R
Address	FB7h							

Bit	Description
[7]	Reserved This bit is reserved and must be programmed to 0.
[6] CPTSEL	Charge Pump Type Select 0: Voltage tripler. 1: Voltage doubler.
[5] VLCDDIR	V_{LCD} Direction 0: Input from external V_{LCD} . 1: Output from internal charge pump or internal VDD as selected by CPEN.
[4] WGENEN	Waveform Generator Enable 0: Disabled. All LCD outputs are held at VSS upon reaching the end of the current waveform. 1: Enabled for normal operation.
[3:0]	Reserved These bits are reserved and must be programmed to 0000.

26.3.8. LCD Display Memory Bank A Subregisters

The twelve LCD Display Memory Bank A subregisters, shown in Table 274, contain LCD Display Memory Bank A data.

Table 274. LCD Display Memory Bank A Subregisters (LCDMEMAx)

Bits	7	6	5	4	3	2	1	0
Field	LCDDATA							
Reset	0	0	0	0	0	0	0	0
R/W	R/W	R/W	R/W	R/W	R/W	R/W	R/W	R/W
Address	If LCDSA = 00h–0Bh in the LCDSA Register, accessible through LCDSD							

Bit	Description
[7:0]	LCD Data
LCDDATA	00–FF: LCD display memory bank data.

26.3.9. LCD Display Memory Bank B Subregisters

The twelve LCD Display Memory Bank B subregisters, shown in Table 275, contain LCD Display Memory Bank B data.

Table 275. LCD Display Memory Bank B Subregisters (LCDMEMBx)

Bits	7	6	5	4	3	2	1	0
Field	LCDDATA							
Reset	0	0	0	0	0	0	0	0
R/W	R/W	R/W	R/W	R/W	R/W	R/W	R/W	R/W
Address	If LCDSA = 10h–1Bh in the LCDSA Register, accessible through LCDSD							

Bit	Description
[7:0]	LCD Data
LCDDATA	00–FF: LCD display memory bank data.

Chapter 27. Flash Memory

The products in the F6482 Series feature either 64KB (65536), 60KB (61440), 32KB (32768), or 16KB (16384) of nonvolatile Flash memory with read/write/erase capability. This Flash memory can be programmed and erased in-circuit by either user code or through the On-Chip Debugger.

The Flash memory array is arranged in pages with 512 bytes per page. The 512-byte page is the minimum Flash memory area that can be erased. Each page is divided into 4 rows of 128 bytes.

For program/data protection, a block of Flash memory can be protected. The size of the protected block is configured to be at the desired page boundary.

The first 2 bytes of Flash Program Memory are used as Flash option bits. For more information about their operation, see the [Flash Option Bit Address Space](#) section on page 546.

Table 276 lists the Flash memory configuration for each device in the F6482 Series; Figure 94 shows the Flash memory arrangement.

Table 276. F6482 Series Flash Memory Configurations

Part Number	Flash Size in KB (Bytes)	Flash Pages	Program Memory Addresses
Z8F6482, Z8F6481	64 (65536)	128	0000h–FFFFh
Z8F6082, Z8F6081	60 (61440)	120	0000h–EFFFh
Z8F3282, Z8F3281	32 (32768)	64	0000h–7FFFh
Z8F1682, Z8F1681	16 (16384)	32	0000h–3FFFh

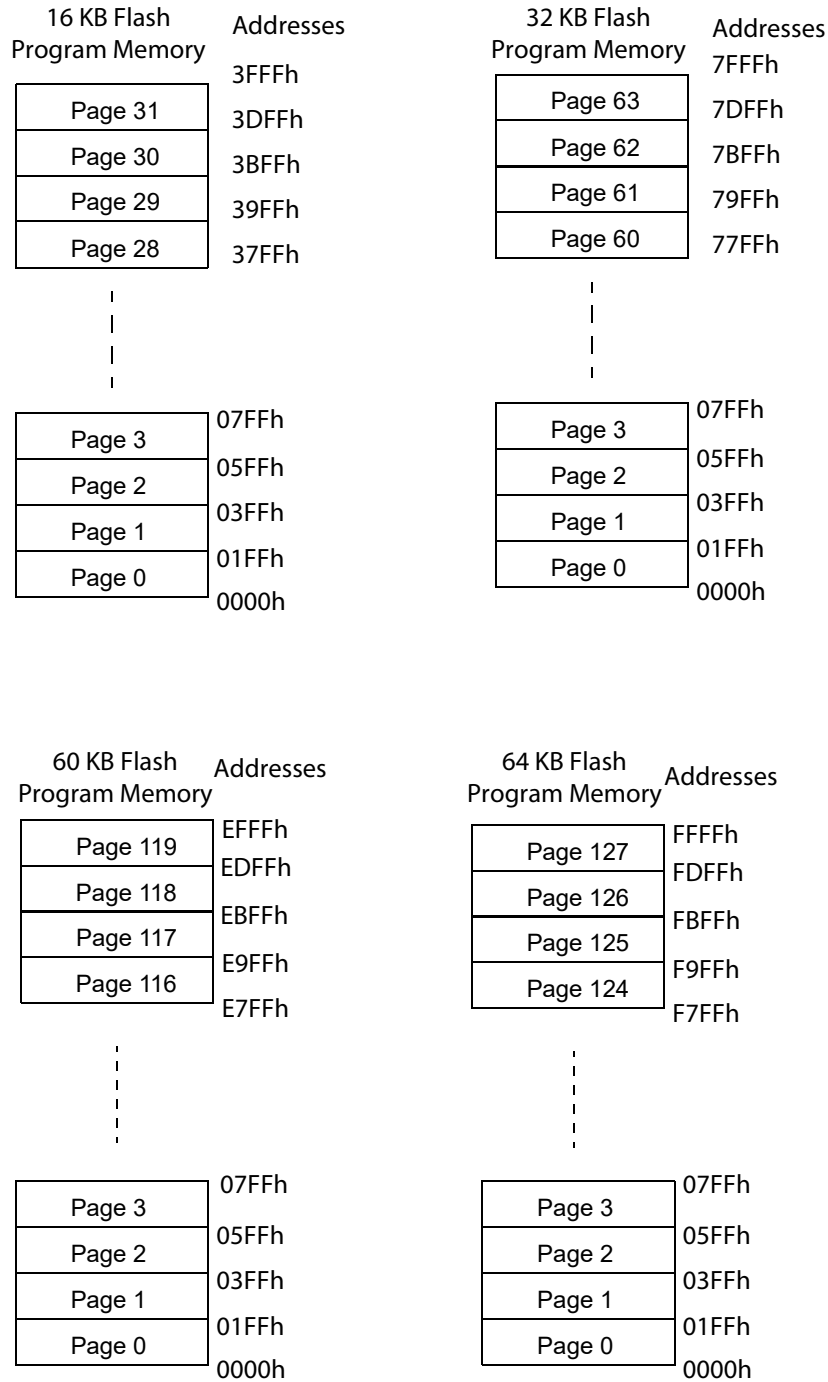

Figure 94. Flash Memory Arrangement

27.1. Flash Information Area

The Flash Information Area is separate from Program Memory and is mapped to the two pages in the address range FC00h to FFFFh. This area is used primarily for factory trimming purposes. Not all of these addresses are user-accessible. The trim bits' working values can be accessed using the Trim Bit Address and Trim Bit Data registers, as described in the [Flash Option Bits](#) chapter on page 542.

To map the Flash Information Area to Program Memory address range FC00h to FFFFh, set the INFO_EN bit in the Flash Page Select Register (FPS).

27.2. Operation

The Flash Controller programs and erases Flash memory, and provides the proper Flash controls and timing for byte programming, Page Erase, and Mass Erase operations in Flash memory. The Flash Controller also contains several protection mechanisms to prevent accidental programming or erasure; these mechanisms operate on the page, block, and full-memory levels.

The flow chart in Figure 95 shows basic Flash Controller operation. The following sections provide details about the Lock, Unlock, Byte Programming, Page Protect, Page Unprotect, Page Select Page Erase, and Mass Erase operations listed in Figure 95.

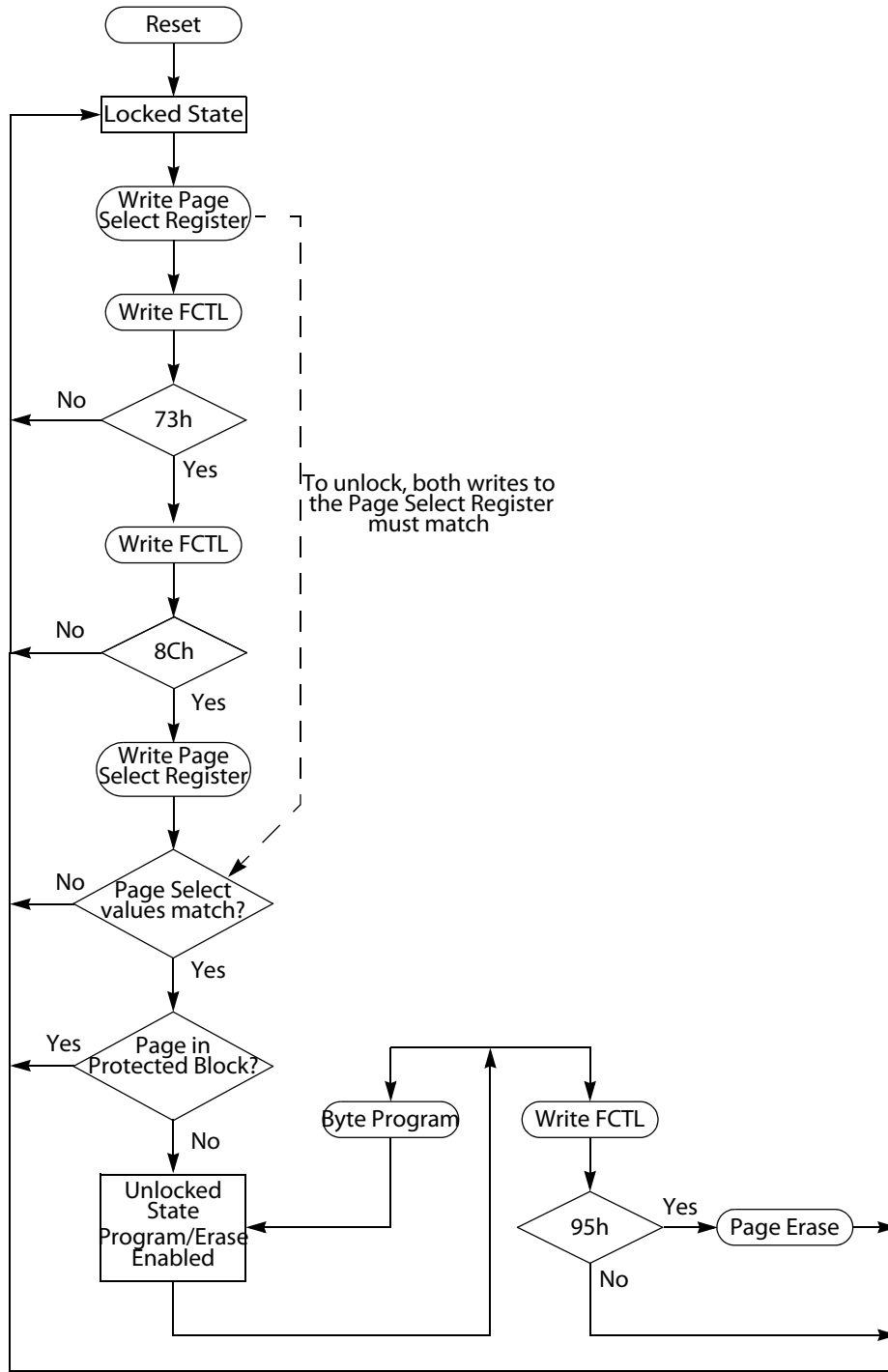

Figure 95. Flash Controller Operation Flowchart

27.2.1. Flash Operation Timing

Before performing either a program or erase operation on Flash memory, the Digitally Controlled Oscillator (DCO) must be running and must be locked using the Frequency Locked Loop (FLL) to a minimum frequency of 1 MHz.

27.2.2. Flash Code Protection Against External Access

The user code contained within Flash memory can be protected against external access with the On-Chip Debugger. Programming the FRP Flash option bit prevents the reading of user code with the On-Chip Debugger. To learn more, see the [Flash Option Bit Address Space](#) section on page 546 and the [On-Chip Debugger](#) section on page 560.

27.2.3. Flash Code Protection Against Accidental Program and Erasure

The F6482 Series provides several levels of protection against accidental program and erasure of the Flash memory contents. This protection is provided by a combination of the Flash option bits, the register locking mechanism, the page select redundancy, and the block level protection control of the Flash Controller.

27.2.3.1. Flash Code Protection Using the Flash Option Bits

The FWP Flash option bit provides Flash Program Memory protection as listed in Table 277. To learn more, see the [Flash Option Bit Address Space](#) section on page 546.

Table 277. Flash Code Protection Using the Flash Option Bit

FWP	Flash Code Protection Description
0	Programming and erasing disabled for all of Flash Program Memory. In user code programming, Page Erase, and Mass Erase are all disabled. Mass Erase is available through the On-Chip Debugger.
1	Programming and Page Erase are enabled for all of Flash Program Memory. Mass Erase is available through the On-Chip Debugger.

27.2.3.2. Flash Code Protection Using the Flash Controller

At Reset, the Flash Controller locks to prevent accidental program or erasure of Flash memory. Observe the following procedure to unlock the Flash Controller from user code:

1. Write the Page Select Register with the target page.
2. Write the first unlock command, 73h, to the Flash Control Register.
3. Write the second unlock command, 8Ch, to the Flash Control Register.
4. Rewrite the Page Select Register with the target page previously stored in this register in [Step 1](#).

If the two Page Select writes do not match, the controller reverts to a locked state. If the two writes match, the selected page becomes active. For details, see [Figure 95 on page 532](#).

► **Note:** The Programming, Page Erase and Mass Erase operations will not be allowed if the FWP bit is cleared or if the page resides in a protected block.

After unlocking a specific page, Byte Programming or Page Erase may be performed. At the conclusion of a Page Erase, the Flash Controller is automatically locked. To lock the Flash Controller after byte programming, write the Flash Control Register with any value other than the Page Erase or Mass Erase commands.

27.2.3.3. Flash Block Protection

The final protection mechanism is implemented on a block basis. Any number of contiguous pages in Flash memory, starting from page 0, can be protected. When set, the FBP_EN bit in the Flash Block Protection Register enables Flash block protection. When Flash block protection is enabled, the FBPS field in the Flash Block Protection Register identifies the page number of the first page that is not protected. All pages below this page are protected.

The Flash Block Protect Register is shared with the Page Select Register, and is selected for access by writing the 5Eh command byte to the Flash Control Register while the Flash Controller is locked. When selected, any subsequent read or write to the Page Select Register targets the Flash Block Protect Register. To deselect the Flash Block Protect Register, write any value to the Flash Control Register.

The Flash Block Protect Register is initialized to 0 on Reset, putting each page into an unprotected state. When the FBP_EN bit in the Flash Block Protect Register is written to 1, the block of Flash pages up to – but not including – the page number in the FBPS field can no longer be written or erased. After the FBP_EN bit of the Flash Block Protect Register has been set, it cannot be cleared except by a System Reset.

27.2.4. Programming

Flash memory is enabled for byte programming on the active page after unlocking the Flash Controller. Erase the address(es) to be programmed using either the Page Erase or Mass Erase command prior to programming. An erased Flash byte contains all ones (FFh). The programming operation can only be used to change bits from 1 to 0. To change a Flash bit (or multiple bits) from 0 to 1 requires execution of either the Page Erase or Mass Erase command.

Programming can be performed using the On-Chip Debugger's Write Memory command or an eZ8 CPU execution of the LDC or LDCI instructions. For a description of these LDC and LDCI instructions, refer to the [eZ8 CPU Core User Manual \(UM0128\)](#), which is

available free for download from the Zilog website. While the Flash Controller programs Flash memory, the eZ8 CPU remains idle, but the system clock and on-chip peripherals continue to operate.

After an address is written, the page remains unlocked, allowing for subsequent writes to other addresses on the same page. To exit programming mode and lock Flash memory, write any value to the Flash Control Register except for the Mass Erase or Page Erase commands.

27.2.5. Byte Programming Mode

If the PMODE field is set to Byte Programming Mode, byte writes to program memory from user code program a byte into Flash.

27.2.6. Word Programming Mode

If the PMODE field is set to Word Programming Mode, Flash memory must be programmed one word (16 bits) at a time. Two byte writes to program memory from user code are required in the following sequence:

1. Byte write to the even address. This byte is registered until either Word Programming is completed or the register is overwritten by a new byte write to an even address.
2. Byte write to the odd address. Writing an odd address triggers Word Programming of the stored even address byte and the current byte to the current word address (LSB ignored).

If only the odd address is written, Byte Programming of the odd address byte is performed and the even address byte in program memory is unchanged.

Each Flash memory row of 128 bytes is subject to a maximum cumulative program time and, as specified in the [Electrical Characteristics](#) chapter on page 601, rows start at address multiples of 0080h. Therefore, the first three rows start at addresses 0000h, 0080h, and 0100h, respectively.



Caution: The byte at each address of Flash memory cannot be programmed (any bits written to 0) more than twice before an erase cycle occurs.

27.2.7. Page Erase

Flash memory can be erased one page (512 bytes) at a time. Page erasing Flash memory sets all bytes in the active page to the value FFh. The Flash Page Select Register identifies the page to be erased. Only a page residing outside the protected block can be erased. With the Flash Controller unlocked, writing the value 95h to the Flash Control Register initiates the Page Erase operation on the active page. While the Flash Controller executes the Page

Erase operation, the eZ8 CPU remains idle, but the system clock and on-chip peripherals continue to operate. The eZ8 CPU resumes operation after the Page Erase operation completes. If the Page Erase operation is performed using the OCD, poll the Flash Status Register to determine when the Page Erase operation is complete. When the Page Erase is complete, the Flash Controller returns to its locked state.

27.2.8. Mass Erase

Flash memory can also be mass erased using the Flash Controller, but only by using the On-Chip Debugger. Mass erasing Flash memory sets all bytes to the value FFh. With the Flash Controller unlocked, writing the value 63h to the Flash Control Register initiates the Mass Erase operation. While the Flash Controller executes the Mass Erase operation, the eZ8 CPU remains idle, but the system clock and on-chip peripherals continue to operate. Using the On-Chip Debugger, poll the Flash Status Register to determine when the Mass Erase operation is complete. When the Mass Erase is complete, the Flash Controller returns to its locked state.

Mass Erase does not affect the user page in the Flash Information Area. Use Page Erase to erase the user page in the Flash Information Area.

27.2.9. Flash Controller Bypass

The Flash Controller can be bypassed so that the control signals for Flash memory can be brought out to the GPIO pins. Bypassing the Flash Controller allows faster Row Programming algorithms by controlling the Flash programming signals directly.

Zilog recommends row programming for gang programming applications and large-volume customers who do not require the in-circuit initial programming of Flash memory. Mass Erase and Page Erase operations are also supported when the Flash Controller is bypassed.

For more information about bypassing the Flash Controller, please [contact Zilog Technical Support](#).

27.2.10. Flash Controller Behavior in Debug Mode

The following changes in the behavior of the Flash Controller occur when the Flash Controller is accessed using the On-Chip Debugger:

- The Flash Write Protect option bit is ignored
- The Flash Block Protect Register is ignored for programming operations
- Programming operations are not limited to the page selected in the Page Select Register
- Bits in the Flash Block Protect Register can be written to 1 or 0
- The second write of the Page Select Register to unlock the Flash Controller is not necessary

- The Page Select Register can be written when the Flash Controller is unlocked.
- The Mass Erase command is enabled through the Flash Control Register



Caution: For security reasons, the Flash controller allows only a single page to be opened for write/erase. When writing multiple Flash pages, the Flash controller must go through the unlock sequence again to select another page.

27.3. Flash Control Register Definitions

This section defines the features of the following Flash Control registers.

Flash Control Register

[Flash Status Register](#): see page 538

[Flash Page Select Register](#): see page 539

[Flash Block Protect Register](#): see page 540

[Flash Programming Configuration](#): see page 541

27.3.1. Flash Control Register

The Flash Controller must remain unlocked when using the Flash Control Register (shown in Table 278) before programming or erasing Flash memory. The Flash Controller is unlocked by writing the Flash Page Select Register, then 73h 8Ch, sequentially, to the Flash Control Register. A final write must then be made to the Flash Page Select Register with the same value as the previous write. When the Flash Controller is unlocked, Mass Erase or Page Erase can be initiated by writing the appropriate command to the FCTL. Page Erase applies only to the active page selected in the Flash Page Select Register. Mass Erase is enabled only through the On-Chip Debugger. Writing an invalid value or an invalid sequence returns the Flash Controller to its locked state. The write-only Flash Control Register shares its Register File address with the read-only Flash Status Register.

Table 278. Flash Control Register (FCTL)

Bits	7	6	5	4	3	2	1	0
Field	FCMD							
Reset	0	0	0	0	0	0	0	0
R/W	W	W	W	W	W	W	W	W
Address	FF8h							

Bit	Description
[7:0] FCMD	Flash Command 73h: First unlock command. 8Ch: Second unlock command. 95h: Page Erase command (must be third command in sequence to initiate Page Erase). 63h: Mass Erase command (must be third command in sequence to initiate Mass Erase). 5Eh: Enable Flash Block Protect Register Access.

27.3.2. Flash Status Register

The Flash Status Register, shown in Table 279, indicates the current state of the Flash Controller. This register can be read at any time. The read-only-only Flash Status Register shares its Register File address with the write-only Flash Control Register.

Table 279. Flash Status Register (FSTAT)

Bits	7	6	5	4	3	2	1	0
Field	Reserved					FSTAT		
Reset	0	0	0	0	0	0	0	0
R/W	R	R	R	R	R	R	R	R
Address	FF8h							

Bit	Description
[7:3]	Reserved These bits are reserved and must be programmed to 00000.
[2:0] FSTAT	Flash Controller Status 000: Flash Controller locked. 001: First unlock command received (73h written). 010: Second unlock command received (8Ch written). 011: Flash Controller unlocked. 100: Block Protect Register selected. 101: Program operation in progress. 110: Page erase operation in progress. 111: Mass erase operation in progress.

27.3.3. Flash Page Select Register

The Flash Page Select Register, shown in Table 280, shares address space with the Flash Block Protect Register. Unless the Flash controller was last written with 5Eh, writes to this address target the Flash Page Select Register.

This register is used to select one of the Flash memory pages to be programmed or erased. Each Flash page contains 512 bytes of Flash memory. During a Page Erase operation, all Flash memory having addresses with the most significant 7 bits provided by FPS[6:0] are chosen for program/erase operation.

Table 280. Flash Page Select Register (FPS)

Bits	7	6	5	4	3	2	1	0
Field	INFO_EN	PAGE						
Reset	0	0	0	0	0	0	0	0
R/W	R/W	R/W	R/W	R/W	R/W	R/W	R/W	R/W
Address	FF9h							

Bit	Description
[7] INFO_EN	<p>Information Area Enable</p> <p>0: Information Area is not selected. 1: Information Area is selected. The Information Area is mapped into the Program Memory address space in the FC00h–FFFFh address range.</p>
[6:0] PAGE	<p>Page Select</p> <p>This 7-bit field identifies the Flash memory page for Page Erase and page unlocking. Program Memory Address[15:9]=PAGE[6:0]. For Z8F3281 devices, the upper bit must always be 0. For Z8F1681 devices, the upper two bits must always be 0.</p>

27.3.4. Flash Block Protect Register

The Flash Block Protect Register, shown in Table 281, is shared with the Flash Page Select Register. This register is selected for access when the [Flash Control Register](#) (see page 537) is written with 5Eh while the Flash Controller is locked. When selected, any subsequent read or write to this address targets the Flash Sector Protect Register. To deselect this register, write any value to the Flash Control Register.

This register selects the size of the Flash memory block to be protected. The reset state of the Flash Block Protect Register is such that Block Protect is not enabled. After the selected block is protected by setting the FBP_EN bit, it can only be unprotected (i.e., the register bits can only be cleared) by a System Reset.

Table 281. Flash Block Protect Register (FBP)

Bits	7	6	5	4	3	2	1	0
Field	FBP_EN	FBPS						
Reset	0	0	0	0	0	0	0	0
R/W	R/W	R/W	R/W	R/W	R/W	R/W	R/W	R/W
Address	FF9h							

Bit	Description (Continued)
[7] FBP_EN	Flash Block Protection Enable 0: Block Protection is not enabled. 1: Block Protection is enabled.
[6:0] FBPS	Flash Block Protection Size This 7-bit field identifies the page number of the first page that is not protected. If the FBP_EN bit is set, all pages below the page number in this field are protected.

27.3.5. Flash Programming Configuration

The Flash Programming Configuration Register, shown in Table 282, contains a PMODE bit that configures the number of bytes that are programmed simultaneously.

Table 282. Flash Programming Configuration Register (FPCONFIG)

Bits	7	6	5	4	3	2	1	0
Field	Reserved							PMODE
Reset	0	0	0	0	0	0	0	0
R/W	R	R	R	R	R	R	R	R/W
Address	FFAh							

Bit	Description (Continued)
[7:1]	Reserved These bits are reserved and must be programmed to 0000000.
[0] PMODE	Programming Mode 0: Byte Programming Mode. 1: Word Programming Mode.

Chapter 28. Flash Option Bits

Programmable Flash option bits allow user configuration of certain aspects of F6482 Series MCU operation. The configuration data are stored in Flash Program Memory and are read during Reset. The features available for control through the Flash option bits include:

- Watchdog Timer time-out response selection – interrupt or System Reset
- Watchdog Timer enabled at Reset
- The ability to prevent unwanted read access to user code in Program Memory
- The ability to prevent accidental programming and erasure of all or a portion of the user code in Program Memory
- The VBO can be configured as always enabled, enabled only during Normal and Halt modes to reduce Stop Mode power consumption, or disabled
- LVD voltage threshold selection
- Factory trimming information for multiple analog functions

28.1. Operation

The following sections describe Flash option bit operation.

28.1.1. Option Bit Configuration by Reset

Each time Flash option bits are programmed or erased, the device must be Reset for changes to take effect. During any Reset operation (System Reset or Stop-Mode Recovery), these Flash option bits are automatically read from Flash Program Memory and written to the Option Configuration registers. These Option Configuration registers control operation of the devices within the F6482 Series MCU. Option bit control is established before the device exits System Reset and before the eZ8 CPU begins code execution. The Option Configuration registers are not part of the Register File and are not accessible for read or write access.

28.1.2. Option Bit Types

The following sections describe the option bit types.

28.1.2.1. User Option Bits

The user option bits are contained in the first two bytes of Program Memory. Zilog provides user access to these bits because these locations contain application-specific device

configurations. The information contained here is lost when page 0 of the Program memory is erased.

28.1.2.2. Trim Option Bits

The trim option bits are contained in the information area of Flash memory. These bits are factory-programmed values required to optimize the operation of onboard analog circuitry and cannot be permanently altered by the user. Program memory can be erased without endangering these values. It is possible to alter working values of these bits by accessing the Trim Bit Address and Data registers, but these working values are lost after a power loss.

There are 32 bytes of trim data. To modify one of these values, the user code must first write a value between 00h and 1Fh into the Trim Bit Address Register. The next write to the Trim Bit Data Register changes the working value of the target trim data byte.

Reading trim data requires the user code to write a value between 00h and 1Fh into the Trim Bit Address Register. The next read from the Trim Bit Data Register returns the working value of the target trim data byte.

► **Note:** The trim address ranges from information address 20–3F only. The remainder of the information area is not accessible via the trim bit address and data registers.

28.1.2.3. Zilog Option Bits

The Zilog option bits are also contained in the information area of Flash memory. These bits are factory-programmed values that configure device peripherals and cannot be altered by the user. Program memory can be erased without endangering these values. Prior to locking the Flash Information Area, it is possible to alter working values of these bits using the OCD Write Option Bits command, but these working values are lost after a power loss. The working value of these bits can be read by using the OCD Read Option Bits command. The programmed value of these bits can be read after selecting the lower information page using the Flash Page Select Register by reading program memory addresses FC00h–FC1Fh.

28.1.2.4. Zilog Device Data

Zilog device data are also contained in the lower information page of Flash memory. These bits are factory-programmed values that contain a part number and other manufacturing information; these values cannot be altered by the user. Program memory can be erased without endangering these values. The value of these bits can be read after selecting the lower information page using the Flash Page Select Register by reading program memory addresses FC40h–FC57h.

28.2. Flash Option Bit Control Register Definitions

This section defines the features of the following Flash option bit registers.

[Trim Bit Address Register \(TRMADR\)](#): see page 545

[Trim Bit Data Register \(TRMDR\)](#): see page 546

[Flash Option Bits at Program Memory Address 0000h](#): see page 546

[Flash Option Bits at Program Memory Address 0001h](#): see page 547

[Trim Bit Address Description](#): see page 548

[Trim Option Bits at Address 0000h \(TBA0\)](#): see page 548

[Trim Option Bits at Address 0001h \(TTEMP0\)](#): see page 549

[Trim Option Bits at Address 0002h \(TTEMP1\)](#): see page 549

[Trim Option Bits at Address 0003h \(TIPO\)](#): see page 550

[Trim Option Bits at Address 0004h \(TLVD_VBO\)](#): see page 550

[Trim Option Bits at Address 0005h \(TVREF\)](#): see page 552

[Trim Option Bits at Address 0006h \(TVBGVREG\)](#): see page 552

[Trim Option Bits at Address 0007h \(TWDT\)](#): see page 553

[Trim Option Bits at Address 0008h \(TLCD0\)](#): see page 553

[Trim Option Bits at Address 0009h \(TLCD1\)](#): see page 554

[Trim Option Bits at Address 000Ah](#): see page 554

[Trim Option Bits at Address 000Bh](#): see page 555

[Trim Option Bits at Address 000Ch \(TVBIAS\)](#): see page 555

28.2.1. Trim Bit Address Register

The Trim Bit Address Register, shown in Table 283, contains the target address for access to the trim option bits. Trim Bit addresses in the range 00h–1Fh map to the Information Area address range 20h–3Fh, as indicated in Table 284.

Table 283. Trim Bit Address Register (TRMADR)

Bit	7	6	5	4	3	2	1	0
Field	Reserved			TRMADR				
Reset	0	0	0	0	0	0	0	0
R/W	R/W	R/W	R/W	R/W	R/W	R/W	R/W	R/W
Address	FF6h							

Bit	Description
[7:5]	Reserved These bits are reserved.
[4:0] TRMADR	Trim Bit Address 00–1F: Selects the trim option bit register accessed when TRMADR is written; see the map in Table 284.

Table 284. Trim Bit Address Map

Trim Bit Address	Information Area Address
00h	20h
01h	21h
02h	22h
03h	23h
:	:
1Fh	3Fh

28.2.2. Trim Bit Data Register

The Trim Bit Data Register, shown in Table 285, contains the read or write data for access to the trim option bits.

Table 285. Trim Bit Data Register (TRMDR)

Bit	7	6	5	4	3	2	1	0
Field	TRMDR							
Reset	0	0	0	0	0	0	0	0
R/W	R/W	R/W	R/W	R/W	R/W	R/W	R/W	R/W
Address	FF7h							

Bit	Description
[7:0]	Trim Bit Data
TRMDR	00–FF: TRMDR is a portal providing access to all trim option bit registers as selected by the TRMADR Register.

28.3. Flash Option Bit Address Space

The first two bytes of Flash Program Memory, at addresses 0000h and 0001h, are reserved for the user-programmable Flash Option bits. See Table 286.

Table 286. Flash Option Bits at Program Memory Address 0000h

Bit	7	6	5	4	3	2	1	0
Field	WDT_RES	WDT_AO	Reserved		VBOCTL		FRP	FWP
Reset*	X	X	X	X	1	1	X	X
R/W	R/W	R/W	R/W	R/W	R/W	R/W	R/W	R/W
Address	Program Memory 0000h							

Note: *RESET = POR reset only; X=undefined; R/W=read/write.

Bit	Description
[7]	Watchdog Timer Reset
WDT_RES	0: Watchdog Timer time-out generates an interrupt request. Interrupts must be globally enabled for the eZ8 CPU to acknowledge the interrupt request. 1: Watchdog Timer time-out causes a System Reset. This setting is the default for unprogrammed (erased) Flash.

Bit	Description (Continued)
[6] WDT_AO	Watchdog Timer Always ON 0: Watchdog Timer is automatically enabled upon application of system power. Watchdog Timer cannot be disabled. 1: Watchdog Timer is enabled upon execution of the WDT instruction. After it is enabled, the Watchdog Timer can only be disabled by a Reset or Stop-Mode Recovery. This setting is the default for unprogrammed (erased) Flash.
[5:4]	Reserved These bits are reserved
[3:2] VBOCTL	Voltage Brown-Out Protection Control 00: Reserved (defaults to disabled). 01: Voltage Brown-Out Protection is disabled. 10: Voltage Brown-Out Protection is enabled in Normal and Halt modes, but is disabled in Stop Mode. 11: Voltage Brown-Out Protection is always enabled. This setting is the default for unprogrammed (erased) Flash.
[1] FRP	Flash Read Protect 0: User program code is inaccessible. Limited control features are available through the On-Chip Debugger. 1: User program code is accessible. All On-Chip Debugger commands are enabled. This setting is default for unprogrammed (erased) Flash.
[0] FWP	Flash Write Protect This option bit provides Flash Program Memory protection: 0: Programming is disabled. Page Erase through user software is disabled. Mass Erase is available using the On-Chip Debugger. 1: Programming, Page Erase and Mass Erase are enabled for all of Flash Program Memory.

Table 287. Flash Option Bits at Program Memory Address 0001h

Bit	7	6	5	4	3	2	1	0
Field	Reserved							
Reset	X	X	X	X	X	X	X	X
R/W	R/W	R/W	R/W	R/W	R/W	R/W	R/W	R/W
Address	Program Memory 0001h							
Note: X=undefined; R/W=read/write.								

Bit	Description
[7:0]	Reserved These bits are reserved.

28.3.1. Trim Bit Address Space

All available trim bit addresses and their functions are summarized in Table 288. For details about each, see [Tables 290 through 301](#).

Table 288. Trim Bit Address Description

Address	Function
0000h	Reserved
0001h	Temperature Sensor Trim0
0002h	Temperature Sensor Trim1
0003h	Internal Precision Oscillator
0004h	VBO and LVD
0005h	DAC and ADC/DAC Reference Voltage
0006h	Band-gap reference and Voltage Regulator
0007h	WDT trim
0008h	LCD Trim0
0009h	LCD Trim1
000Ah	Reserved
000Bh	Reserved
000Ch	VBIAS Trim
000Dh–001Fh	Reserved

28.3.1.1. Trim Bit Address Register 0000h

The Trim Option Bits Register at address 0000h, shown in Table 289, is reserved.

Table 289. Trim Option Bits at Address 0000h (TBA0)

Bit	7	6	5	4	3	2	1	0
Field	Reserved							
Reset	0	0	0	0	0	0	0	0
R/W	R	R	R	R	R	R	R	R
Address	Information Page Memory 0020h							

Note: X = undefined; R/W = read/write; R = read-only.

Bit	Description
[7:0]	Reserved All bits are reserved.

28.3.1.2. Trim Bit Addresses 0001h and 0002h

The Trim Option Bits registers at addresses 0001h and 00002h, shown in Tables 290 and 291, govern control of the temperature sensor trim bits.

Table 290. Trim Option Bits at Address 0001h (TTEMP0)

Bit	7	6	5	4	3	2	1	0
Field	Reserved		TS_GAIN					
Reset	X	X	X	X	X	X	X	X
R/W	R/W	R/W	R/W	R/W	R/W	R/W	R/W	R/W
Address	Information Page Memory 0021h							
Note: X = undefined; R/W = read/write; R = read-only.								

Bit	Description
[7:6]	Reserved These bits are reserved.
[5:0] TS_GAIN	Temperature Gain Trim Bits Contains gain trimming bits for the Temperature Sensor.

Table 291. Trim Option Bits at Address 0002h (TTEMP1)

Bit	7	6	5	4	3	2	1	0
Field	TS_OFFSET							
Reset	X	X	X	X	X	X	X	X
R/W	R/W	R/W	R/W	R/W	R/W	R/W	R/W	R/W
Address	Information Page Memory 0022h							
Note: X = undefined; R/W = read/write; R = read-only.								

Bit	Description
[7:0] TS_OFFSET	Temperature Sensor Offset Trim Bits Contains offset trimming bits for the Temperature Sensor.

28.3.1.3. Trim Bit Address 0003h

The Trim Option Bits Register at address 0003h, shown in Table 292, governs control of the Internal Precision Oscillator trim bits.

Table 292. Trim Option Bits at Address 0003h (TIPO)

Bit	7	6	5	4	3	2	1	0
Field	Reserved		IPO_TRIM					
Reset	X	X	X	X	X	X	X	X
R/W	R/W	R/W	R/W	R/W	R/W	R/W	R/W	R/W
Address	Information Page Memory 0023h							

Note: X = undefined; R/W = read/write; R = read-only.

Bit	Description
[7:6]	Reserved. These bits are reserved.
[5:0]	Internal Precision Oscillator Trim Bits
IPO_TRIM	Contains trimming bits for Internal Precision Oscillator.

28.3.1.4. Trim Bit Address 0004h

The Trim Option Bits Register at address 0004h, shown in Table 293, governs control of the Voltage Brown-Out and Low Voltage Detect trim bits.

Table 293. Trim Option Bits at Address 0004h (TLVD_VBO)

Bit	7	6	5	4	3	2	1	0
Field	VBO_TRIM			LVD_TRIM				
Reset*	1	1	1	X	X	X	X	X
R/W	R/W	R/W	R/W	R/W	R/W	R/W	R/W	R/W
Address	Information Page Memory 0024h							

Note: *RESET = POR reset only; X=undefined; R/W = read/write; R = read-only.

Bit	Description
[7:5] VBO_TRIM	Voltage Brown Out Trim
[4:0] LVD_TRIM	Low Voltage Detect Trim This trimming affects the low-voltage detection threshold. Each LSB represents a 50mV change in the threshold level. Alternatively, the low voltage threshold can be computed from the options bit value by the following equation: $\text{LVD_LVL} = 3.3\text{V} - \text{LVD_TRIM} * 0.05\text{V}$ Typical LVD_TRIM values are listed in Table 294.

Table 294. LVD_Trim Values

LVD_TRIM	LVD Threshold (V)			Description
	Minimum	Typical	Maximum	
00000		3.20		Maximum LVD threshold
00001		3.15		
00010		3.10		
00011		3.05		
00100		3.00		
00101		2.95		
00110		2.90		
00111		2.85		
01000		2.80		
01001		2.75		
01010		2.70		
01011		2.65		
01100		2.60		
01101		2.55		
01110		2.50		
01111		2.45		
10000		2.40		
10001		2.35		
10010		2.30		
10011		2.25		
10100		2.20		
10101		2.15		
10110		2.10		
10111		2.05		
11000		2.00		
11001		1.95		
11010		1.90		
11011		1.85		
11100		1.80		
11101		1.75		
11110		1.70		
11111		1.65		Minimum LVD threshold; default on Reset.

28.3.1.5. Trim Bit Address 0005h

In the Trim Option Bits Register at address 0005h and shown in Table 295, govern control of the DAC and ADC/DAC Voltage Reference (V_{REF}).

Table 295. Trim Option Bits at Address 0005h (TVREF)

Bit	7	6	5	4	3	2	1	0
Field	DAC_TRIM				VREF_TRIM			
Reset	X	X	X	X	X	X	X	X
R/W	R/W	R/W	R/W	R/W	R/W	R/W	R/W	R/W
Address	Information Page Memory 0025h							
Note: X = undefined; R/W = read/write; R = read-only.								

Bit	Description
[7:4] DAC_TRIM	DAC Trim
[3:0] VREF_TRIM	ADC/DAC Voltage Reference Trim

28.3.1.6. Trim Bit Address 0006h

The Trim Option Bits Register at address 0006h, shown in Table 296, governs control of the bandgap and voltage regulator trim bits.

Table 296. Trim Option Bits at Address 0006h (TVBGVREG)

Bit	7	6	5	4	3	2	1	0
Field	VBG_TRIM				Reserved	VREG_TRIM		
Reset*	0	0	0	0	0	1	0	1
R/W	R/W	R/W	R/W	R/W	R	R/W	R/W	R/W
Address	Information Page Memory 0026h							
Note: *RESET = POR reset only; X=undefined; R/W = read/write.								

Bit	Description
[7:4] VBG_TRIM	Bandgap Voltage Trim
[3]	Reserved This bit is reserved.
[2:0] VREG_TRIM	Voltage Regulator Trim

28.3.1.7. Trim Bit Address 0007h

The Trim Option Bits Register at address 0007h (see Table 297), governs control of the WDT.

Table 297. Trim Option Bits at Address 0007h (TWDT)

Bit	7	6	5	4	3	2	1	0
Field	Reserved		WDT_TRIM					
Reset	0	1	X	X	X	X	X	X
R/W	R	R/W	R/W	R/W	R/W	R/W	R/W	R/W
Address	Information Page Memory 0027h							
Note: X = undefined; R/W = read/write; R = read-only.								

Bit	Description
[7]	Reserved This bit is reserved and is factory-programmed to 0.
[6]	Reserved This bit is reserved and is factory-programmed to 1.
[5:0] WDT_TRIM	WDT Trim

28.3.1.8. Trim Bit Addresses 0008h and 0009h

The Trim Option Bits registers at addresses 0008h and 0009h, shown in Tables 298 and 299, govern control of the LCD trim bits.

Table 298. Trim Option Bits at Address 0008h (TLCD0)

Bit	7	6	5	4	3	2	1	0
Field	Reserved	LCDCO_TRIM			LCDVREG_TRIM			
Reset	0	X	X	X	X	X	X	X
R/W	R	R/W	R/W	R/W	R/W	R/W	R/W	R/W
Address	Information Page Memory 0028h							
Note: X = undefined; R/W = read/write; R = read-only.								

Bit	Description
[7]	Reserved This bit is reserved.
[6:4] LCDCO_TRIM	LCD Contrast Offset Trim
[3:0] LCDVREG_TRIM	LCD Voltage Regulator and Current Bias Trim

Table 299. Trim Option Bits at Address 0009h (TLCD1)

Bit	7	6	5	4	3	2	1	0
Field	Reserved						LCDCG_TRIM	
Reset	0	0	0	0	0	0	X	X
R/W	R	R	R	R	R	R	R/W	R/W
Address	Information Page Memory 0029h							

Note: X = undefined; R/W = read/write; R = read-only.

Bit	Description
[7:2]	Reserved These bits are reserved.
[1:0] LCDCG_TRIM	LCD Contrast Gain (Step Size) Trim

28.3.1.9. Trim Bit Address 000Ah

All bits in the Trim Option Bits registers at addresses 000Ah and 0000Bh, shown in Tables 300 and 301, are reserved for future use.

Table 300. Trim Option Bits at Address 000Ah

Bit	7	6	5	4	3	2	1	0
Field	Reserved							
Reset	0	0	0	0	0	0	0	X
R/W	R	R	R	R	R	R	R	R/W
Address	Information Page Memory 002Ah							

Note: X = undefined; R/W = read/write; R = read-only.

Bit	Description
[7:0]	Reserved All bits are reserved.

28.3.1.10. Trim Bit Address 000Bh

Table 301. Trim Option Bits at Address 000Bh

Bit	7	6	5	4	3	2	1	0
Field	Reserved							
Reset	0	0	0	0	X	X	X	X
R/W	R	R	R	R	R/W	R/W	R/W	R/W
Address	Information Page Memory 002Bh							
Note: X = undefined; R/W = read/write; R = read-only.								

Bit	Description
[7:0]	Reserved All bits are reserved.

28.3.1.11. Trim Bit Address 000Ch

In the Trim Option Bits Register at address 000Ch and shown in Table 302, govern control of the 1.25V VBIAS Voltage Reference (V_{BIAS}).

Table 302. Trim Option Bits at Address 000Ch (TVBIAS)

Bit	7	6	5	4	3	2	1	0
Field	Reserved					VBIAS_TRIM		
Reset	0	0	0	0	0	X	X	X
R/W	R	R	R	R	R	R/W	R/W	R/W
Address	Information Page Memory 002Ch							
Note: X = undefined; R/W = read/write; R = read-only.								

Bit	Description
[7:3]	Reserved These bits are reserved.
[2:0] VBIAS_TRIM	VBIAS (1.25V) Reference Trim

Chapter 29. Non-Volatile Data Storage

Many of the F6482 Series devices contain a 128-byte Non-Volatile Data Storage (NVDS) element. This data memory can perform over 100,000 write cycles.

29.1. Operation

The NVDS is implemented by special-purpose Zilog software stored in areas of program memory not accessible to users. These special-purpose routines use Flash memory to store the data. The routines incorporate a dynamic addressing scheme to maximize the write/erase endurance of Flash memory.

► **Note:** Not all members of the F6482 Series feature NVDS. To learn more, see [Table 1](#) on page 3.

29.2. NVDS Code Interface

Two routines are required to access the NVDS: a write routine and a read routine. Both of these routines are accessed with a CALL instruction to a predefined address outside the program memory space accessible to users. Both the NVDS address and data are single-byte values. To prevent the user code from being disturbed, these routines save the working register set before using it; therefore, 16 bytes of stack space is required to preserve the site. After finishing the call to these routines, the working register set of the user code is recovered.

During both read and write accesses to the NVDS, interrupt service is *not* disabled. Any interrupts that occur during the NVDS execution must not disturb the working register and existing stack contents; otherwise, the array becomes corrupted. Zilog recommends disabling interrupts before executing NVDS operations.

Use of the NVDS requires 16 bytes of available stack space. The contents of the working register set are saved before calling NVDS read or write routines.

For correct NVDS operation, Flash operation timing requirements must be met. To learn more, see the [Flash Operation Timing](#) section on page 533.

29.2.1. Byte Write

To write a byte to the NVDS array, the user code must first push the address, then the data byte, onto the stack. The user code issues a CALL instruction to the address of the Byte Write routine (0xF3FD). At the return from the subroutine, the write status byte resides in

working register R0. The bit fields of this status byte are defined in Table 303. Additionally, the user code should pop the address and data bytes off the stack.

The write routine uses 16 bytes of stack space in addition to the two bytes of address, and data pushed by the user code. Sufficient memory must be available for this stack usage.

Because of the Flash memory architecture, NVDS writes exhibit a nonuniform execution time. In general, a write takes 136µs (assuming a 20MHz system clock). For every 256 writes, however, a maintenance operation is necessary. In this rare occurrence, the write takes up to 58ms to complete. Slower system clock speeds result in proportionally higher execution times.

NVDS byte writes to illegal addresses (those exceeding the NVDS array size) have no effect. Illegal write operations have a 7µs execution time.

As is the case for writing to Flash memory, before performing a write operation on the NVDS, the FLL must be running at a minimum of 1 MHz.

Word write is not available.

Table 303. Write Status Byte

Bit	7	6	5	4	3	2	1	0
Field	Reserved				IGADDR	WRERROR		
Default Value	0	0	0	X	0	0	0	0

Bit	Description
[7:4]	Reserved All bits are reserved and must be programmed to 0000.
[3] IGADDR	Illegal Address 0: The write attempted was to a legal address (one that is within the NVDS array size). 1: The write attempted was to an illegal address (one that exceeds the NVDS array size).
[2:0] WRERROR	NVDS Write Error 0: No NVDS write error occurred. 1–7: An NVDS write error occurred. The memory location accessed may be corrupt. Attempting the write again may succeed because the NVDS routines will attempt to select a different memory location.

29.2.2. Byte Read

To read a byte from the NVDS array, user code must first push the address onto the stack. User code issues a CALL instruction to the address of the byte-read routine (i.e., 0xF000). At the return from the subroutine, the read byte resides in working register R0, and the read status byte resides in working register R1; the bit fields of this status byte are defined in Table 304. In addition, the user code should pop the address byte off the stack.

The read routine uses 16 bytes of stack space in addition to the 1 byte of address pushed by the user. Sufficient memory must be available for this stack usage. Because of the Flash memory architecture, NVDS reads exhibit a nonuniform execution time. A read operation takes between 71 μ s and 258 μ s (assuming a 20MHz system clock). Slower system clock speeds result in proportionally higher execution times.

NVDS byte reads from illegal addresses (those exceeding the NVDS array size) return a value of 0xFF. Illegal read operations have a 6 μ s execution time. The status byte returned by the NVDS read routine is zero upon a successful read. A nonzero status byte indicates that there is a corrupted value in the NVDS array at the location being read. In this case, the value returned in R0 is the byte most recently written to the array that does not have an error.

Table 304. Read Status Byte

Bit	7	6	5	4	3	2	1	0
Field	Reserved				IGADDR	RDERROR	Reserved	
Default Value	0	0	0	0	0	0	0	0

Bit	Description
[7:4]	Reserved All bits are reserved and must be programmed to 0000.
[3] IGADDR	Illegal Address 0: The write attempted was to a legal address (one that is within the NVDS array size). 1: The write attempted was to an illegal address (one that exceeds the NVDS array size).
[2] RDERROR	NVDS Read Error 0: No NVDS read error occurred. 1–7: An NVDS read error occurred. This bit is set when there is a possible corruption of the data at the address read.
[1:0]	Reserved All bits are reserved and must be programmed to 00.

29.2.3. Power Failure Protection

The NVDS routines employ error checking mechanisms to ensure that a power failure will endanger only the most recently written byte. Bytes previously written to an array are not perturbed.

A System Reset (such as a pin reset or a watchdog timer reset) that occurs during a write operation also perturbs the byte currently being written. All other bytes in the array remain unperturbed.

29.2.4. Optimizing NVDS Memory Usage for Execution Speed

As indicated in Table 305, the NVDS read time varies drastically. These discrepancies are a trade-off for minimizing the frequency of writes that require post-write page erases. The NVDS read time of address N is a function of the number of writes to addresses other than N since the most recent write to address N, as well as the number of writes since the most recent page erase. Aside from the effects caused by page erases and results caused by the initial condition in which the NVDS is blank, a rule of thumb is that every write since the most recent page erase causes read times of unwritten addresses to increase by 0.8 μ s up to a maximum of 258 μ s.

Table 305. NVDS Access Latency

Operation	Minimum Latency (μ s)	Maximum Latency (μ s)
Read	71	258
Write	126	136
Illegal Read	6	6
Illegal Write	7	7

If NVDS read performance is critical to your software architecture, you can optimize your code for speed by using either of the following methods:

Periodically refresh all addresses that are used. This method is the more useful of the two methods because the optimal use of NVDS in terms of speed is to rotate the writes evenly among all addresses planned for use, thereby bringing all reads closer to the minimum read time. Because the minimum read time is much less than the write time, however, actual speed benefits are not always realized.

Use as few unique addresses as possible. This method helps to optimize the impact of refreshing.

Chapter 30. On-Chip Debugger

The F6482 Series device contains an integrated On-Chip Debugger (OCD) that provides advanced debugging features that include:

- Reading and writing of the Register File
- Reading and writing of Program and Data Memory
- Setting of breakpoints
- Executing eZ8 CPU instructions

30.1. Architecture

The OCD consists of four primary functional blocks:

- Transmitter
- Receiver
- Auto-baud detector/generator
- Debug controller

Figure 96 shows the architecture of the On-Chip Debugger.

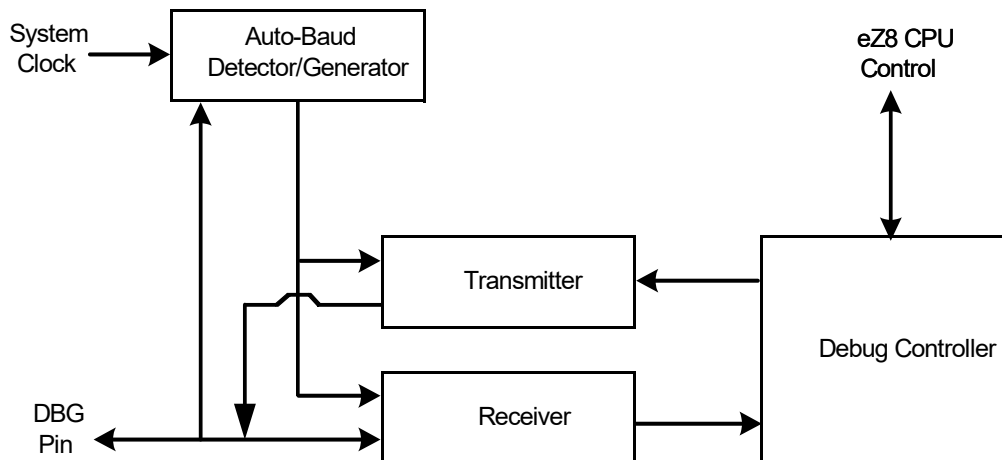

Figure 96. On-Chip Debugger Block Diagram

30.2. Operation

This section describes the OCD interface and its operation in debug and high-speed synchronous modes as well as baud rates, OCD data formats, resets, breakpoints and flow control.

30.2.1. Development System Overview

The development system consists of:

- Host computer running Zilog Developer Studio II (ZDS II), a full-featured Integrated Development Environment (IDE)
- USB Smart Cable to interface the computer running ZDS II to the DBG connector on the system under development
- The system under development with a 6-pin DBG connector to access the Zilog microcontroller DBG pin which is used by the On-Chip Debugger (OCD) for communication with an external host

Figure 97 depicts the development system.

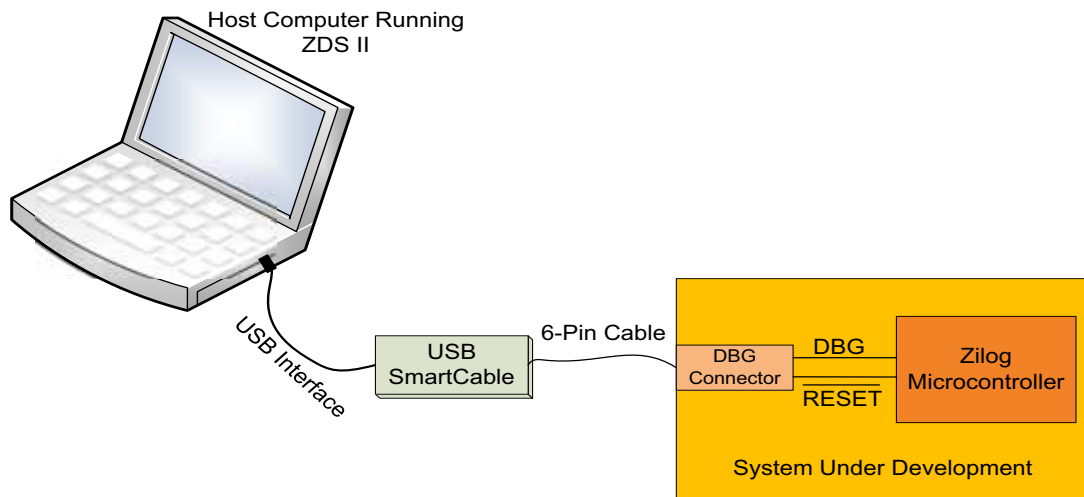

Figure 97. Development System

30.2.2. On-Chip Debugger Interface

The On-Chip Debugger (OCD) uses the DBG pin for communication with an external host. This one-pin interface is a bidirectional open-drain interface that transmits and receives data. Data transmission is half-duplex, in that transmit and receive cannot occur simultaneously. The serial data on the DBG pin is sent using the standard asynchronous data format defined in RS-232. This pin interfaces the F6482 Series device to the serial port of a host PC using minimal external hardware. Figure 98 shows the connections between the debug connector and the Z8 Encore! microcontroller. Two different methods for connecting the DBG pin to an RS-232 interface are depicted in Figures 99 and 100.

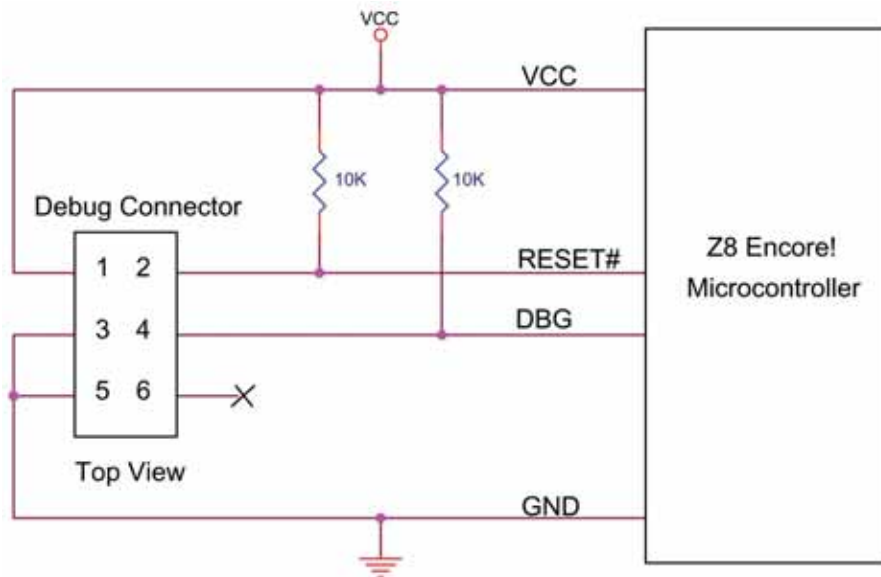

Figure 98. Target OCD Connector Interface

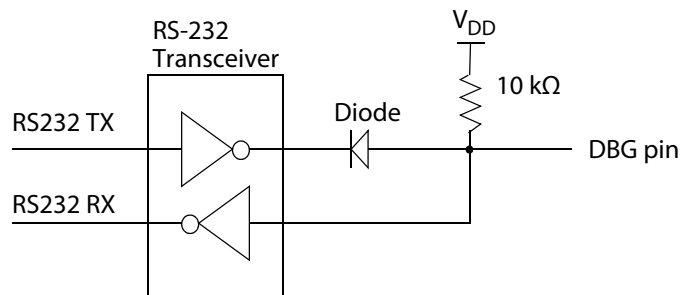

Figure 99. Interfacing the On-Chip Debugger's DBG Pin with an RS-232 Interface, #1 of 2



Caution: For proper operation of the F6482 Series device, all power pins (V_{DD} and AV_{DD}) must be supplied with power, and all ground pins (V_{SS} and AV_{SS}) must be properly grounded. The DBG pin should always be connected to V_{DD} through an external pull-up resistor.

The Serial Smart Cable (SSC) does not work with the F6482 device series because it does not fully support the silicon OCD. During external clock switching, the OCD sends a break command to the SSC. This causes the SSC to disconnect from the target and terminate the debug session. You must then reconnect to the target again. Use the Opto-Isolated USB, USB, or Ethernet Smart Cables when using in conjunction with ZDSII.

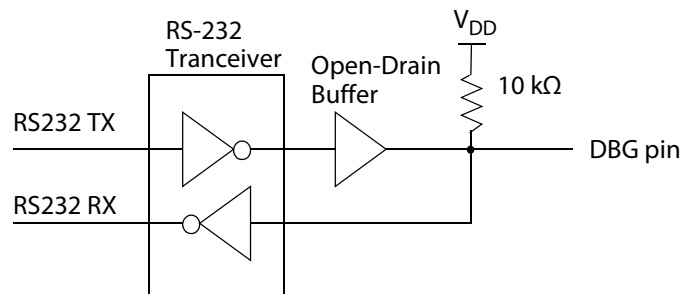

Figure 100. Interfacing the On-Chip Debugger's DBG Pin with an RS-232 Interface, #2 of 2

30.2.3. Debug Mode

The operating characteristics of the F6482 Series device in Debug Mode are:

- The eZ8 CPU fetch unit stops, thereby idling the eZ8 CPU, unless directed by the OCD to execute specific instructions
- The system clock operates unless in Stop Mode
- All enabled on-chip peripherals operate unless in Stop Mode or otherwise defined by the on-chip peripheral to disable in Debug Mode
- Automatically exits Halt Mode
- Constantly refreshes the Watchdog Timer, if enabled

30.2.3.1. Entering Debug Mode

The device enters Debug Mode following any of these operations:

- Writing the DBGMODE bit in the OCD Control Register to 1 using the OCD interface
- eZ8 CPU execution of a breakpoint (BRK) instruction (when enabled)
- Match of PC to OCDCNTR Register (when enabled)
- OCDCNTR Register decrements to 0000h (when enabled)
- The DBG pin is Low when the device exits Reset

30.2.3.2. Exiting Debug Mode

The device exits Debug Mode following any of these operations:

- Clearing the DBGMODE bit in the OCD Control Register to 0
- Power-on reset
- Voltage Brown-Out reset
- Asserting the $\overline{\text{RESET}}$ pin Low to initiate a Reset
- Driving the DBG pin Low when the device is in Stop Mode initiates a System Reset

30.2.4. OCD Data Format

The On-Chip Debugger (OCD) interface uses the asynchronous data format defined for RS-232. Each character is transmitted as 1 start bit, 8 data bits (least-significant bit first), and 1 stop bit; see Figure 101.

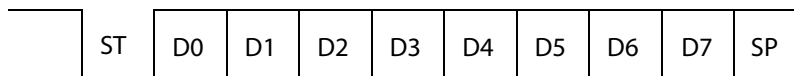

ST=Start Bit
SP=Stop Bit
D0-D7=Data Bits

Figure 101. OCD Data Format

30.2.5. OCD Auto-Baud Detector/Generator

To run over a range of baud rates (bits per second) with differing system clock frequencies, the On-Chip Debugger has an Auto-Baud Detector/Generator. After a reset, the OCD is idle until it receives data. The OCD requires that the first character sent from the host is the character 80h, which contains eight continuous bits Low (1 start bit plus 7 data bits). The Auto-Baud Detector measures this period and sets the OCD Baud Rate Generator accordingly.

The Auto-Baud Detector/Generator is clocked by the system clock. The minimum baud rate is the system clock frequency divided by 512. If the data can be synchronized with the system clock, the autobaud generator can run as high as the system clock frequency (1 clock/bit). The maximum recommended baud rate is the system clock frequency divided by 8. Table 306 lists minimum and recommended maximum baud rates for sample crystal frequencies.

Table 306. OCD Baud-Rate Limits

System Clock Frequency	Maximum Asynchronous Baud Rate (bits/s)	Minimum Baud Rate (bits/s)
20.0MHz	2.5M	39.1k
1.0MHz	125k	1.96k
32kHz	4096	64

If the OCD receives a Serial Break (ten or more continuous bits Low), the Auto-Baud Detector/Generator resets. The Auto-Baud Detector/Generator can then be reconfigured by sending 80h. If the Auto-Baud Detector overflows while measuring the Auto-Baud character, the Auto-Baud Detector will remain reset.

30.2.6. High-Speed Synchronous Communication

It is possible to operate the serial On-Chip Debugger at high speeds. To operate at high speeds, data must be synchronized with an external clock. High-speed synchronous communication will only work when using an external clock source. To operate in high-speed synchronous mode, simply Auto-Baud to the desired speed. The Auto-Baud generator will automatically run at the desired baud rate.

Slow bus rise times due to the pull-up resistor become a limiting factor when operating at high speeds. To compensate for slow rise times, the output driver can be configured to drive the line High. If the Transmit Drive (TXD) bit is set, the line will be driven both High and Low during transmission. The line starts being driven at the beginning of the start bit and stops being driven at the middle of the stop bit. If the Transmit Drive High (TXDH) bit is set, the line will be driven High until the input is High or until the center of the bit occurs, whichever occurs first. If both TXD and TXDH are set, the pin will be driven High for one clock period at the beginning of each 0-to-1 transition. An example of a high-speed synchronous interface is shown in Figure 102.

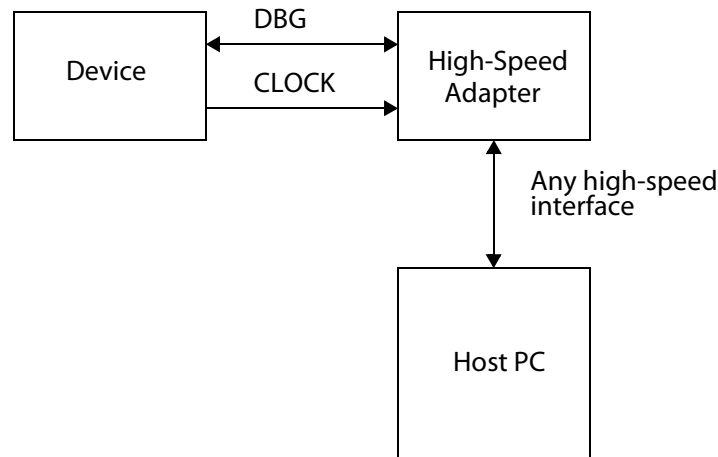

Figure 102. Synchronous Operation

30.2.7. OCD Serial Errors

The On-Chip Debugger can detect any of the following error conditions on the DBG pin:

- Serial Break (a minimum of ten continuous bits Low)
- Framing Error (the received stop bit is Low)
- Transmit Collision (OCD and host simultaneous transmission detected by the OCD)

When the OCD detects one of these errors, it aborts any command currently in progress, transmits a Serial Break 4096 system clock cycles long back to the host, and resets the Auto-Baud Detector/Generator. A Framing Error or Transmit Collision can be caused by the host sending a Serial Break to the OCD. Because of the open-drain nature of the interface, returning a Serial Break back to the host only extends the length of the Serial Break if the host releases the Serial Break early.

The host transmits a Serial Break on the DBG pin when first connecting to the F6482 Series device or when recovering from an error. A Serial Break from the host resets the Auto-Baud Generator/Detector but does not reset the OCD Control Register. A Serial Break leaves the device in Debug Mode if that is the current mode. The OCD is held in Reset until the end of the Serial Break when the DBG pin returns High. Because of the open-drain nature of the DBG pin, the host can send a Serial Break to the OCD even if the OCD is transmitting a character.

30.2.8. Automatic Reset

The F6482 Series devices have the capability to switch clock sources during operation. If the Auto-Baud is set and the clock source is switched, the Auto-Baud value becomes invalid. A new Auto-Baud value must be configured with the new clock frequency.

The oscillator control logic has clock switch detection. If a clock switch is detected and the Auto-Baud is set, the device will automatically send a Serial Break for 4096 clocks. This will reset the Auto-Baud and indicate to the host that a new Auto-Baud character should be sent. Each of the following conditions can be detected as a clock source switch:

- The values of SCKDIV or SCKSEL in the CLKCTL0 Register have been changed
- A write to CLKCTL3 when DCOEN = 1 and FLEN = 1 in the CLKCTL5 Register and SCKSEL = 000 (DCO is the System Clock)
- A write to CLKCTL6 when DCOEN = 1 and FLEN = 0 in the CLKCTL5 Register and SCKSEL = 000 (DCO is the System Clock)

30.2.9. Transmit Flow Control

Transmit flow control is implemented by the use of a remote start bit. When transmit flow control is enabled, the transmitter will wait for the remote host to send the start bit. Transmit flow control is useful in applications in which receive overruns can occur.

The remote host can transmit a remote start bit by sending the character FFh. The transmitter will append its data after the start bit. Due to the *wire and* nature of the open-drain bus, the start bit sent by the remote host and the data bits sent by the F6482 Series device appear as one character, as shown in Figure 103.

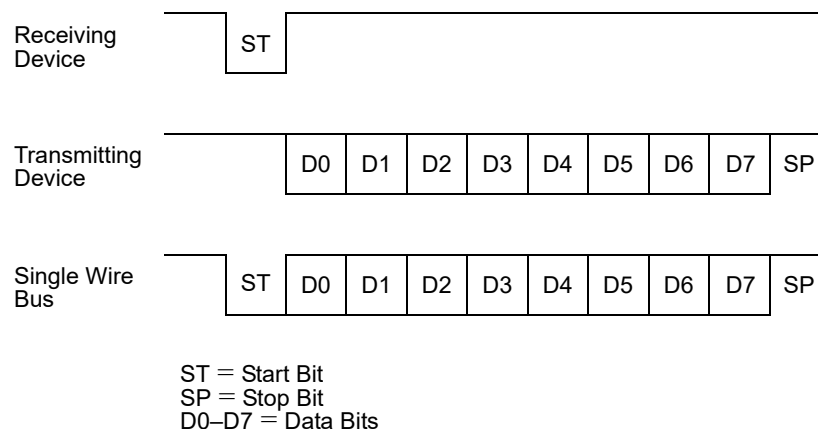

Figure 103. Start Bit Flow Control

30.2.10. Breakpoints

Execution breakpoints are generated using the BRK instruction (op code 00h). When the eZ8 CPU decodes a BRK instruction, it signals the On-Chip Debugger. If breakpoints are enabled, the OCD idles the eZ8 CPU and enters Debug Mode. If breakpoints are not enabled, the OCD ignores the BRK signal and the BRK instruction operates as a NOP instruction.

If breakpoints are enabled, the OCD can be configured to automatically enter Debug Mode, or to loop on the break instruction. If the OCD is configured to loop on the BRK instruction, then the CPU remains able to service interrupt requests.

The loop on BRK instruction can service interrupts in the background. For interrupts to be serviced in the background, there cannot be any breakpoints in the interrupt service routine. Otherwise, the CPU stops on the breakpoint in the interrupt routine. For interrupts to be serviced in the background, interrupts must also be enabled. Interrupts are typically disabled during critical sections of code in which interrupts do not occur (such as adjusting the stack pointer or modifying shared data).

Through the OCD, host debugger software can poll the IDLE bit of the OCDSTAT Register to determine if the OCD is looping on a BRK instruction. When the host wants to stop the CPU on the BRK instruction on which it is looping, the host must not set the DBG-MODE bit of the OCDCTL Register. The CPU may have vectored to an interrupt service routine. Instead, the host clears the BRKLOOP bit to allow the CPU to finish the interrupt service routine it may be in, then return to the BRK instruction. When the CPU returns to the BRK instruction on which it was previously looping, it automatically sets the DBG-MODE bit and enters Debug Mode.

The majority of the OCD commands remain disabled when the eZ8 CPU is looping on a BRK instruction. The eZ8 CPU must be in Debug Mode before these commands can be issued.

30.2.10.1. Breakpoints in Flash Memory

The BRK instruction is op code 00h, which corresponds to the fully programmed state of a byte in Flash memory. To implement a breakpoint, write 00h to the desired address, overwriting the current instruction. To remove a breakpoint, erase the corresponding page of Flash memory and reprogram with the original data.

30.2.11. OCD Counter Register

The On-Chip Debugger contains a multipurpose 16-bit counter register that can be used for the following tasks:

- Count system clock cycles between breakpoints
- Generate a BRK when it counts down to 0
- Generate a BRK when its value matches the Program Counter

When configured as a counter, the OCDCNTR Register starts counting when the On-Chip Debugger exits Debug Mode, and stops counting when it reenters Debug Mode or when it reaches the maximum count of FFFFh. The OCDCNTR Register automatically resets itself to 0000h when the OCD exits Debug Mode if it is configured to count clock cycles between breakpoints.

If the OCDCNTR Register is configured to generate a BRK when it counts down to zero, it will not be reset when the CPU starts running. The counter will start counting down toward zero when the On-Chip Debugger exits Debug Mode. If the On-Chip Debugger enters Debug Mode before the OCDCNTR Register counts down to zero, the OCDCNTR will stop counting.

If the OCDCNTR Register is configured to generate a BRK when the program counter matches the OCDCNTR Register, the OCDCNTR Register will not be reset when the CPU resumes executing and it will not be decremented when the CPU is running. A BRK will be generated when the program counter matches the value in the OCDCNTR Register before executing the instruction at the location of the program counter.



Caution: The OCDCNTR Register is used by many of the OCD commands. It counts the number of bytes for the register and memory read/write commands. It retains the residual value when generating the CRC. If the OCDCNTR is used to generate a BRK, its value must be written as a final step before exiting Debug Mode.

Because this register is overwritten by multiple OCD commands, it must only be used to generate temporary breakpoints, such as stepping over CALL instructions or running to a specific instruction and stopping.

When the OCDCNTR Register is read, it returns the inverse of the data in this register. The OCDCNTR Register is only decremented when counting. The mode in which it counts the number of clock cycles in between execution is achieved by counting down from its maximum count. When the OCDCNTR Register is read, the counter appears to have counted up because its value is inverted. The value in this register is always inverted when it is read. If this register is used as a hardware breakpoint, the value read from this register will be the inverse of the data actually in the register.

30.3. On-Chip Debugger Commands

The host communicates to the On-Chip Debugger by sending OCD commands using the DBG interface. During normal operation, only a subset of the OCD commands are available. In Debug Mode, all OCD commands become available unless the user code is protected by programming the Flash Read Protect option bit (FRP). This FRP option bit prevents the code in memory from being read out of the F6482 Series device. When this option is enabled, several of the OCD commands are disabled.

Table 307 summarizes the On-Chip Debugger commands. Each of these commands is described in further detail in the section that follows the table. The table indicates those commands that operate when the device is not in Debug Mode (normal operation) and those commands that are disabled by programming the Flash Read Protect option bit.

Table 307. On-Chip Debugger Commands

Debug Command	Command Byte	Enabled When <i>Not</i> in Debug Mode?	Disabled by Read Protect Option Bit
Read Revision	00h	Yes	–
Write OCD Counter Register	01h	–	–
Read OCD Status Register	02h	Yes	–
Read OCD Counter Register	03h	–	–
Write OCD Control Register	04h	Yes	–
Read OCD Control Register	05h	Yes	–
Write Program Counter	06h	–	Disabled
Read Program Counter	07h	–	Disabled
Write Register	08h	–	Writes to on-chip peripheral registers are enabled. Writes to the on-chip RAM are disabled.
Read Register	09h	–	Reads from on-chip peripheral registers are enabled. Reads from the on-chip RAM are disabled.
Write Program Memory	0Ah	–	Disabled
Read Program Memory	0Bh	–	Disabled
Write Data Memory	0Ch	–	Disabled
Read Data Memory	0Dh	–	Disabled
Read Program Memory CRC	0Eh	–	–
Reserved	0Fh	–	–
Step Instruction	10h	–	Disabled
Stuff Instruction	11h	–	Disabled
Execute Instruction	12h	–	Disabled
Write Line Control Register	18h	–	–
Read Line Control Register	19h	–	–
Read Baud Reload Register	1Bh	–	–

Note: Unlisted command byte values are reserved.

In the following OCD Commands, data and commands sent from the host to the On-Chip Debugger are identified by $\text{DBG} \leftarrow \text{Command/Data}$. Data sent from the On-Chip Debugger back to the host is identified by $\text{DBG} \rightarrow \text{Data}$.

Read Revision (00h). The Read OCD Revision command determines the version of the On-Chip Debugger. If OCD commands are added, removed, or changed, this revision number changes.

```
DBG ← 00h
DBG → REVID[15:8] (Major revision number)
DBG → REVID[7:0] (Minor revision number)
```

Write OCD Counter Register (01h). The Write OCD Counter Register command writes the data that follows to the OCDCNTR Register. If the device is not in Debug Mode, the data is discarded.

```
DBG ← 01h
DBG ← OCDCNTR[15:8]
DBG ← OCDCNTR[7:0]
```

Read OCD Status Register (02h). The Read OCD Status Register command reads the OCDSTAT Register.

```
DBG ← 02h
DBG → OCDSTAT[7:0]
```

Read OCD Counter Register (03h). The OCD Counter Register can be used to count system clock cycles in between breakpoints, generate a BRK when it counts down to 0, or generate a BRK when its value matches the Program Counter. Because this register is really a downcounter, the returned value is inverted when this register is read; therefore, the returned result appears to be an upcounter. If the device is not in Debug Mode, this command returns FFFFh.

```
DBG ← 03h
DBG → ~OCDCNTR[15:8]
DBG → ~OCDCNTR[7:0]
```

Write OCD Control Register (04h). The Write OCD Control Register command writes the data that follows to the OCDCTL Register.

```
DBG ← 04h
DBG ← OCDCTL[7:0]
```

Read OCD Control Register (05h). The Read OCD Control Register command reads the value of the OCDCTL Register.

```
DBG ← 05h
DBG → OCDCTL[7:0]
```

Write Program Counter (06h). The Write Program Counter command writes the data that follows to the eZ8 CPU's Program Counter (PC). If the device is not in Debug Mode or if the Read Protect Option bit is enabled, the Program Counter (PC) values are discarded.

```
DBG ← 06h
DBG ← ProgramCounter [15:8]
DBG ← ProgramCounter [7:0]
```

Read Program Counter (07h). The Read Program Counter command reads the value in the eZ8 CPU's Program Counter (PC). If the device is not in Debug Mode or if the Read Protect option bit is enabled, this command returns FFFFh.

```
DBG ← 07h
DBG → ProgramCounter [15:8]
DBG → ProgramCounter [7:0]
```

Write Register (08h). The Write Register command writes data to the Register File. Data can be written 1–256 bytes at a time (256 bytes can be written by setting size to 0). If the device is not in Debug Mode, the address and data values are discarded. If the Read Protect option bit is enabled, then only writes to the on-chip peripheral registers are allowed and all other register write data values are discarded.

```
DBG ← 08h
DBG ← {0h, Register Address [11:8] }
DBG ← Register Address [7:0]
DBG ← Size [7:0]
DBG ← 1-256 data bytes
```

Read Register (09h). The Read Register command reads data from the Register File. Data can be read 1–256 bytes at a time (256 bytes can be read by setting *size* to zero). If the device is not in Debug Mode, or if the Read Protect option bit is enabled and on-chip RAM is being read from, this command returns FFh for all of the data values.

```
DBG ← 09h
DBG ← {0h, Register Address [11:8] }
DBG ← Register Address [7:0]
DBG ← Size [7:0]
DBG → 1-256 data bytes
```

Write Program Memory (0Ah). The Write Program Memory command writes data to Program Memory. This command is equivalent to the LDC and LDCI instructions. Data can be written 1–65536 bytes at a time (65536 bytes can be written by setting size to 0). The on-chip Flash Controller must be written and unlocked for the programming operation to occur. If the Flash Controller is not unlocked, the data is discarded. If the device is not in Debug Mode, or if the Read Protect option bit is enabled, the data is discarded.

```
DBG ← 0Ah
DBG ← Program Memory Address [15:8]
DBG ← Program Memory Address [7:0]
```



```
DBG ← Size[15:8]
DBG ← Size[7:0]
DBG ← 1-65536 data bytes
```

Read Program Memory (0Bh). The Read Program Memory command reads data from Program Memory. This command is equivalent to the LDC and LDCI instructions. Data can be read 1–65536 bytes at a time (65536 bytes can be read by setting *size* to 0). If the device is not in Debug Mode or if the Read Protect option bit is enabled, this command returns FFh for the data.

```
DBG ← 0Bh
DBG ← Program Memory Address[15:8]
DBG ← Program Memory Address[7:0]
DBG ← Size[15:8]
DBG ← Size[7:0]
DBG → 1-65536 data bytes
```

Write Data Memory (0Ch). The Write Data Memory command writes data to Data Memory. This command is equivalent to the LDE and LDEI instructions. Data is written 1–65536 bytes at a time (65536 bytes can be written by setting *size* to 0). If the device is not in Debug Mode, or if the Read Protect option bit is enabled, the data is discarded.

```
DBG ← 0Ch
DBG ← Data Memory Address[15:8]
DBG ← Data Memory Address[7:0]
DBG ← Size[15:8]
DBG ← Size[7:0]
DBG ← 1-65536 data bytes
```

Read Data Memory (0Dh). The Read Data Memory command reads from Data Memory. This command is equivalent to the LDE and LDEI instructions. Data can be read 1 to 65536 bytes at a time (65536 bytes can be read by setting *size* to 0). If the device is not in Debug Mode, this command returns FFh for the data.

```
DBG ← 0Dh
DBG ← Data Memory Address[15:8]
DBG ← Data Memory Address[7:0]
DBG ← Size[15:8]
DBG ← Size[7:0]
DBG → 1-65536 data bytes
```

Read Program Memory CRC (0Eh). The Read Program Memory CRC command computes and returns the cyclic redundancy check (CRC) of Program Memory using the 16-bit CRC-CCITT polynomial ($x^{16} + x^{12} + x^5 + 1$). The CRC is preset to all ones. The least-significant bit of the data is shifted through the polynomial first. The CRC is inverted when it is transmitted. If the device is not in Debug Mode, this command returns FFFFh for the CRC value. Unlike most other OCD Read commands, there is a delay from the issuance of the command until the OCD returns the data. The OCD reads the Program Memory, calcu-

lates the CRC value, and returns the result. The delay is a function of the Program Memory size and is approximately equal to the system clock period multiplied by the number of bytes in Program Memory.

```
DBG ← 0Eh
DBG → CRC [15:8]
DBG → CRC [7:0]
```

Step Instruction (10h). The Step Instruction command steps one assembly instruction at the current Program Counter (PC) location. If the device is not in Debug Mode, or if the Read Protect Option bit is enabled, the OCD ignores this command.

```
DBG ← 10h
```

Stuff Instruction (11h). The Stuff Instruction command steps one assembly instruction and allows specification of the first byte of the instruction. The remaining 0–4 bytes of the instruction are read from Program Memory. This command is useful for stepping over instructions wherein the first byte of the instruction has been overwritten by a breakpoint. If the device is not in Debug Mode, or if the Read Protect option bit is enabled, the OCD ignores this command.

```
DBG ← 11h
DBG ← op code [7:0]
```

Execute Instruction (12h). The Execute Instruction command allows sending an entire instruction to be executed to the eZ8 CPU. This command can also step over breakpoints. The number of bytes to send for the instruction depends on the op code. If the device is not in Debug Mode, or if the Read Protect option bit is enabled, the OCD ignores this command.

```
DBG ← 12h
DBG ← 1-5 byte op code
```

Write Line Control Register (18h). The Write Line Control Register command writes the data that follows to the Line Control Register.

```
DBG ← 18h
DBG ← LCR [7:0]
```

Read Line Control Register (19h). The Read Line Control Register command returns the current value in the Line Control Register.

```
DBG ← 19h
DBG → LCR [7:0]
```

Read Baud Reload Register (1Bh). The Read Baud Reload Register command returns the current value in the Baud Reload Register.

```
DBG ← 1Bh
DBG → BAUD [15:8]
DBG → BAUD [7:0]
```

30.4. On-Chip Debugger Control Register Definitions

This section defines the features of the following On-Chip Debugger control registers.

OCD Control Register

[OCD Status Register](#): see page 577

[Line Control Register](#): see page 577

[Baud Reload Register](#): see page 578

30.4.1. OCD Control Register

The OCD Control Register, shown in Table 308, controls the state of the On-Chip Debugger. This register is used to enter or exit Debug Mode and to enable the BRK instruction. It can also reset the F6482 Series device.

A *reset and stop* function can be achieved by writing 81h to this register. A *reset and go* function is achieved by writing 41h to this register. If the device is in Debug Mode, a *run* function is implemented by writing 40h to this register.

Table 308. OCD Control Register (OCDCTL)

Bit	7	6	5	4	3	2	1	0
Field	DBGMODE	BRKEN	DBGACK	BRKLOOP	BRKPC	BRKZRO	Reserved	RST
Reset	0	0	0	0	0	0	0	0
R/W	R/W	R/W	R/W	R/W	R/W	R/W	R/W	R/W

Bit	Description
[7] DBGMODE	<p>Debug Mode</p> <p>Setting this bit to 1 causes the device to enter Debug Mode. When in Debug Mode, the eZ8 CPU stops fetching new instructions. Clearing this bit causes the eZ8 CPU to resume execution. This bit is automatically set when a BRK instruction is decoded and breakpoints are enabled.</p> <p>0: The device is running (operating in Normal Mode). 1: The device is in Debug Mode.</p>
[6] BRKEN	<p>Breakpoint Enable</p> <p>This bit controls the behavior of BRK instruction (op code 00h). By default, breakpoints are disabled and the BRK instruction behaves like a NOP. If this bit is set to 1 and a BRK instruction is decoded, the OCD takes action depending upon the BRKLOOP bit.</p> <p>0: BRK instruction is disabled. 1: BRK instruction is enabled.</p>

Bit	Description (Continued)
[5] DBGACK	<p>Debug Acknowledge</p> <p>This bit enables the debug acknowledge feature. If this bit is set to 1, then the OCD sends a Debug Acknowledge character (FFh) to the host when a breakpoint occurs. This bit automatically clears itself when an acknowledge character is sent.</p> <p>0: Debug Acknowledge is disabled. 1: Debug Acknowledge is enabled.</p>
[4] BRKLOOP	<p>Breakpoint Loop</p> <p>This bit determines what action the OCD takes when a BRK instruction is decoded and breakpoints are enabled (BRKEN is 1). If this bit is 0, the DBGMODE bit is automatically set to 1 and the OCD enters Debug Mode. If BRKLOOP is set to 1, the eZ8 CPU loops on the BRK instruction.</p> <p>0: BRK instruction sets DBGMODE to 1. 1: eZ8 CPU loops on BRK instruction.</p>
[3] BRKPC	<p>Break when PC == OCDCNTR</p> <p>If this bit is set to 1, then the OCDCNTR Register is used as a hardware breakpoint. When the program counter matches the value in the OCDCNTR Register, DBGMODE is automatically set to 1. If this bit is set, the OCDCNTR Register does not count when the CPU is running.</p> <p>0: OCDCNTR is setup as counter. 1: OCDCNTR generates hardware break when PC == OCDCNTR.</p>
[2] BRKZRO	<p>Break when OCDCNTR == 0000h</p> <p>If this bit is set, then the OCD automatically sets the DBGMODE bit when the OCDCNTR Register counts down to 0000h. If this bit is set, the OCDCNTR Register is not reset when the part exits Debug Mode.</p> <p>0: OCD does not generate BRK when OCDCNTR decrements to 0000h. 1: OCD sets DBGMODE to 1 when OCDCNTR decrements to 0000h.</p>
[1]	<p>Reserved</p> <p>This bit is reserved and must be programmed to 0.</p>
[0] RST	<p>Reset</p> <p>Setting this bit to 1 resets the device. The controller goes through a normal POR sequence with the exception that the On-Chip Debugger is not reset. This bit is automatically cleared to 0 when the reset finishes.</p> <p>0: No effect. 1: Reset the device.</p>

30.4.2. OCD Status Register

The OCD Status Register, shown in Table 309, reports status information about the current state of the debugger and the system.

Table 309. OCD Status Register (OCDSTAT)

Bit	7	6	5	4	3	2	1	0
Field	IDLE	HALT	RPEN	Reserved				
Reset	0	0	0	0				
R/W	R	R	R	R				

Bit	Description
[7] IDLE	CPU Idle This bit is set if the part is in Debug Mode (DBGMODE is 1) or if a BRK instruction has occurred since the last time OCDCTL was written. This can be used to determine if the CPU is running or if it is idle. 0: The eZ8 CPU is running. 1: The eZ8 CPU is either stopped or looping on a BRK instruction.
[6] HALT	Halt Mode 0: The device is not in Halt Mode. 1: The device is in Halt Mode.
[5] RPEN	Read Protect Option Bit Enabled 0: The Read Protect option bit is disabled (Flash option bit is 1). 1: The Read Protect option bit is enabled (Flash option bit is 0), disabling many OCD commands.
[4:0]	Reserved These bits are reserved and must be programmed to 00000.

30.4.3. Line Control Register

The OCD Line Control Register, shown in Table 310, is used to configure the output driver characteristics during transmission. This register is only used in high-speed implementations.

Table 310. OCD Line Control Register (OCDLCR)

Bit	7	6	5	4	3	2	1	0
Field	Reset		NBTX	NBEN	TXFC	TXDH	TXD	TXHD
Reset	00		0	0	0	0	0	0
R/W	R		R/W	R/W	R/W	R/W	R/W	R/W

Bit	Description
[7:6]	Reset
[5] NBTX	Nine Bit Transmit This control bit sets the polarity of the ninth bit when nine bit mode is enabled. 0: Ninth bit is zero. 1: Ninth bit is one.
[4] NBEN	Nine Bit Enable This control bit enables nine bit mode. This setting is useful when transmit flow control using a remote start bit is enabled to detect valid characters. 0: Nine Bit Mode disabled. 1: Nine Bit Mode enabled.
[3] TXFC	Transmit Flow Control 0: Transmit Flow Control disabled. 1: Transmit Flow Control using Remote Start bit.
[2] TXDH	Transmit Drive High 0: Pin is not driven High during 0 to 1 transitions. 1: Pin is driven High during 0 to 1 transitions.
[1] TXD	Transmit Drive 0: Pin is only driven Low during transmission (Open-Drain). 1: Pin is always driven during transmission.
[0] TXHD	Transmit High Drive Strength 0: Pin output driver is low drive strength. 1: Pin output driver is high drive strength.

30.4.4. Baud Reload Register

The Baud Reload Register contains the measured auto-baud value.

Table 311. Baud Reload Register

Bit	15	14	13	12	11	10	9	8	7	6	5	4	3	2	1	0
Field	Reserved				RELOAD											
Reset	0h				000h											
R/W	R				R											



Bit	Description
[15:12]	Reserved These bits are reserved and must be set to 0000.
[11:0] RELOAD	Baud Reload Value This value is the measured Auto-Baud value. Its value can be calculated using the following formula: $\text{RELOAD} = \frac{\text{SYSCLK}}{\text{BAUDRATE}} \times 8$

Chapter 31. eZ8 CPU Instruction Set

This chapter describes assembly language programming and syntax, plus all facets of the eZ8 instruction set.

31.1. Assembly Language Programming Introduction

The eZ8 CPU assembly language provides a means for writing an application program without concern for actual memory addresses or machine instruction formats. A program written in assembly language is called a source program. Assembly language allows the use of symbolic addresses to identify memory locations. It also allows mnemonic codes (op codes and operands) to represent the instructions themselves. The op codes identify the instruction while the operands represent memory locations, registers, or immediate data values.

Each assembly language program consists of a series of symbolic commands called statements. Each statement contains labels, operations, operands and comments.

Labels are assigned to a particular instruction step in a source program. The label identifies that step in the program as an entry point for use by other instructions.

The assembly language also includes assembler directives that supplement the machine instruction. The assembler directives, or *pseudo-ops*, are not translated into a machine instruction. Rather, these pseudo-ops are interpreted as directives that control or assist the assembly process.

A source program is processed (assembled) by the assembler to obtain a machine language program called the *object code*; this object code is executed by the eZ8 CPU. An example segment of an assembly language program is presented in Table 312.

Table 312. Assembly Language Source Program Example

JP START	; Everything after the semicolon is a comment.
START:	; A label called START. The first instruction (JP START) in this ; example causes program execution to jump to the point within the ; program where the START label occurs.
LD R4, R7	; A Load (LD) instruction with two operands. The first operand, ; Working Register R4, is the destination. The second operand, ; Working Register R7, is the source. The contents of R7 is ; written into R4.

Table 312. Assembly Language Source Program Example (Continued)

LD 234h, #%01	; Another Load (LD) instruction with two operands. ; The first operand, Extended Mode Register Address 234h, ; identifies the destination. The second operand, Immediate Data ; value 01h, is the source. The value 01h is written into the ; Register at address 234h.
---------------	---

31.2. Assembly Language Syntax

For proper instruction execution, eZ8 CPU assembly language syntax requires that the operands be written as destination and source. After assembly, the object code usually orders the operands as *source, destination*, but ordering is op code-dependent. The two instruction examples that follow illustrate the format of some basic assembly instructions and the resulting object code produced by the assembler. You must follow this binary format if you prefer manual program coding or intend to implement your own assembler.

Example 1. If the contents of registers 43h and 08h are added, and the result is stored in 43h; the assembly syntax and resulting object code is as listed in Table 313.

Table 313. Assembly Language Syntax Example 1

Assembly Language Code	ADD	43h,	08h	(ADD dst, src)
Object Code	04	08	43	(OPC src, dst)

Example 2. In general, when an instruction format requires an 8-bit register address, that address can specify any register location in the range 0–255 or, using Escaped Mode Addressing, a Working Register R0–R15. If the contents of Register 43h and Working Register R8 are added and the result is stored in 43h, the assembly syntax and resulting object code is as listed in Table 314.

Table 314. Assembly Language Syntax Example 2

Assembly Language Code	ADD	43h,	R8	(ADD dst, src)
Object Code	04	E8	43	(OPC src, dst)

The register file size varies depending on the device type.

31.3. eZ8 CPU Instruction Notation

In the [eZ8 CPU Instruction Summary](#) section on page 588, the operands, condition codes, status flags and address modes are represented by the notational shorthand provided in Table 315.

Table 315. Notational Shorthand

Notation	Description	Operand	Range
b	Bit	b	b represents a value from 0 to 7 (000b to 111b)
cc	Condition Code	–	See the Condition Codes overview in the eZ8 CPU Core User Manual (UM0128)
DA	Direct Address	Addr	Addr. represents a number in the range of 0000h to FFFFh
ER	Extended Addressing Register	Reg	Reg. represents a number in the range of 000h to FFFh
IM	Immediate Data	#Data	Data is a number between 00h to FFh
Ir	Indirect Working Register	@Rn	n=0 –15
IR	Indirect Register	@Reg	Reg. represents a number in the range of 00h to FFh
Irr	Indirect Working Register Pair	@RRp	p=0, 2, 4, 6, 8, 10, 12 or 14
IRR	Indirect Register Pair	@Reg	Reg. represents an even number in the range 00h to FEh
p	Polarity	p	Polarity is a single bit binary value of either 0b or 1b.
r	Working Register	Rn	n=0–15
R	Register	Reg	Reg. represents a number in the range of 00h to FFh
RA	Relative Address	X	X represents an index in the range of +127 to –128, which is an offset relative to the address of the next instruction
rr	Working Register Pair	RRp	p=0, 2, 4, 6, 8, 10, 12 or 14
RR	Register Pair	Reg	Reg. represents an even number in the range of 00h to FEh
Vector	Vector Address	Vector	Vector represents a number in the range of 00h to FFh
X	Indexed	#Index	The register or register pair to be indexed is offset by the signed Index value (#Index) in a +127 to –128 range.

Table 316 contains additional symbols that are used throughout the [eZ8 CPU Instruction Summary](#) section on page 588.

Table 316. Additional Symbols

Symbol	Definition
dst	Destination Operand
src	Source Operand
@	Indirect Address Prefix
SP	Stack Pointer
PC	Program Counter
FLAGS	Flags Register
RP	Register Pointer
#	Immediate Operand Prefix
B	Binary Number Suffix
%	Hexadecimal Number Prefix
H	Hexadecimal Number Suffix

Assignment of a value is indicated by an arrow. For example, the statement:

$$\text{dst} \leftarrow \text{dst} + \text{src}$$

indicates that the source data is added to the destination data and the result is stored in the destination location.

31.4. eZ8 CPU Instruction Classes

eZ8 CPU instructions are divided functionally into the following groups:

- Arithmetic
- Bit Manipulation
- Block Transfer
- CPU Control
- Load
- Logical
- Program Control
- Rotate and Shift

[Tables 317 through 324](#) contain the instructions belonging to each group and the number of operands required for each instruction. Some instructions appear in more than one table, because these instructions should be considered as a subset of more than one category. Within these tables, the source operand is identified as *src*, the destination operand is *dst*, and the condition code is *cc*.

Table 317. Arithmetic Instructions

Mnemonic	Operands	Instruction
ADC	dst, src	Add with Carry
ADCX	dst, src	Add with Carry using Extended Addressing
ADD	dst, src	Add
ADDX	dst, src	Add using Extended Addressing
CP	dst, src	Compare
CPC	dst, src	Compare with Carry
CPCX	dst, src	Compare with Carry using Extended Addressing
CPX	dst, src	Compare using Extended Addressing
DA	dst	Decimal Adjust
DEC	dst	Decrement
DECW	dst	Decrement Word
INC	dst	Increment
INCW	dst	Increment Word
MULT	dst	Multiply
SBC	dst, src	Subtract with Carry
SBCX	dst, src	Subtract with Carry using Extended Addressing
SUB	dst, src	Subtract
SUBX	dst, src	Subtract using Extended Addressing

Table 318. Bit Manipulation Instructions

Mnemonic	Operands	Instruction
BCLR	bit, dst	Bit Clear
BIT	p, bit, dst	Bit Set or Clear
BSET	bit, dst	Bit Set
BSWAP	dst	Bit Swap
CCF	–	Complement Carry Flag
RCF	–	Reset Carry Flag
SCF	–	Set Carry Flag
TCM	dst, src	Test Complement Under Mask
TCMX	dst, src	Test Complement Under Mask using Extended Addressing
TM	dst, src	Test Under Mask
TMX	dst, src	Test Under Mask using Extended Addressing

Table 319. Block Transfer Instructions

Mnemonic	Operands	Instruction
LDCI	dst, src	Load Constant to/from Program Memory and Autoincrement Addresses
LDEI	dst, src	Load External Data to/from Data Memory and Autoincrement Addresses

Table 320. CPU Control Instructions

Mnemonic	Operands	Instruction
ATM	–	Atomic Execution
CCF	–	Complement Carry Flag
DI	–	Disable Interrupts
EI	–	Enable Interrupts
HALT	–	Halt Mode
NOP	–	No Operation
RCF	–	Reset Carry Flag
SCF	–	Set Carry Flag
SRP	src	Set Register Pointer

Table 320. CPU Control Instructions (Continued)

Mnemonic	Operands	Instruction
STOP	–	Stop Mode
WDT	–	Watchdog Timer Refresh

Table 321. Load Instructions

Mnemonic	Operands	Instruction
CLR	dst	Clear
LD	dst, src	Load
LDC	dst, src	Load Constant to/from Program Memory
LDCI	dst, src	Load Constant to/from Program Memory and Autoincrement Addresses
LDE	dst, src	Load External Data to/from Data Memory
LDEI	dst, src	Load External Data to/from Data Memory and Autoincrement Addresses
LDWX	dst, src	Load Word using Extended Addressing
LDX	dst, src	Load using Extended Addressing
LEA	dst, X(src)	Load Effective Address
POP	dst	Pop
POPX	dst	Pop using Extended Addressing
PUSH	src	Push
PUSHX	src	Push using Extended Addressing

Table 322. Logical Instructions

Mnemonic	Operands	Instruction
AND	dst, src	Logical AND
ANDX	dst, src	Logical AND using Extended Addressing
COM	dst	Complement
OR	dst, src	Logical OR
ORX	dst, src	Logical OR using Extended Addressing
XOR	dst, src	Logical Exclusive OR
XORX	dst, src	Logical Exclusive OR using Extended Addressing

Table 323. Program Control Instructions

Mnemonic	Operands	Instruction
BRK	–	On-Chip Debugger Break
BTJ	p, bit, src, DA	Bit Test and Jump
BTJNZ	bit, src, DA	Bit Test and Jump if Non-Zero
BTJZ	bit, src, DA	Bit Test and Jump if Zero
CALL	dst	Call Procedure
DJNZ	dst, src, RA	Decrement and Jump Non-Zero
IRET	–	Interrupt Return
JP	dst	Jump
JP cc	dst	Jump Conditional
JR	DA	Jump Relative
JR cc	DA	Jump Relative Conditional
RET	–	Return
TRAP	vector	Software Trap

Table 324. Rotate and Shift Instructions

Mnemonic	Operands	Instruction
BSWAP	dst	Bit Swap
RL	dst	Rotate Left
RLC	dst	Rotate Left through Carry
RR	dst	Rotate Right
RRC	dst	Rotate Right through Carry
SRA	dst	Shift Right Arithmetic
SRL	dst	Shift Right Logical
SWAP	dst	Swap Nibbles

31.5. eZ8 CPU Instruction Summary

Table 325 summarizes the eZ8 CPU instructions. This table identifies the addressing modes employed by the instruction, the effect upon the Flags Register, the number of CPU clock cycles required for the instruction fetch and the number of CPU clock cycles required for the instruction execution.

Table 325. eZ8 CPU Instruction Summary

Assembly Mnemonic	Symbolic Operation	Address Mode		Op Code(s) (Hex)	Flags						Fetch Cycles	Instr. Cycles
		dst	src		C	Z	S	V	D	H		
ADC dst, src	$dst \leftarrow dst + src + C$	r	r	12	*	*	*	*	0	*	2	3
		r	lr	13							2	4
		R	R	14							3	3
		R	IR	15							3	4
		R	IM	16							3	3
		IR	IM	17							3	4
ADCX dst, src	$dst \leftarrow dst + src + C$	ER	ER	18	*	*	*	*	0	*	4	3
		ER	IM	19							4	3
ADD dst, src	$dst \leftarrow dst + src$	r	r	02	*	*	*	*	0	*	2	3
		r	lr	03							2	4
		R	R	04							3	3
		R	IR	05							3	4
		R	IM	06							3	3
		IR	IM	07							3	4
ADDX dst, src	$dst \leftarrow dst + src$	ER	ER	08	*	*	*	*	0	*	4	3
		ER	IM	09							4	3

Note: Flags notation:

*=Value is a function of the result of the operation.

=Unaffected.

X=Undefined.

0=Reset to 0.

1=Set to 1.

Table 325. eZ8 CPU Instruction Summary (Continued)

Assembly Mnemonic	Symbolic Operation	Address Mode		Op Code(s) (Hex)	Flags						Fetch Cycles	Instr. Cycles
		dst	src		C	Z	S	V	D	H		
AND dst, src	dst ← dst AND src	r	r	52	-	*	*	0	-	-	2	3
		r	lr	53							2	4
		R	R	54							3	3
		R	IR	55							3	4
		R	IM	56							3	3
		IR	IM	57							3	4
ANDX dst, src	dst ← dst AND src	ER	ER	58	-	*	*	0	-	-	4	3
		ER	IM	59							4	3
ATM	Block all interrupt and DMA requests during execution of the next 3 instructions			2F	-	-	-	-	-	-	1	2
BCLR bit, dst	dst[bit] ← 0	r		E2	-	*	*	0	-	-	2	2
BIT p, bit, dst	dst[bit] ← p	r		E2	-	*	*	0	-	-	2	2
BRK	Debugger Break			00	-	-	-	-	-	-	1	1
BSET bit, dst	dst[bit] ← 1	r		E2	-	*	*	0	-	-	2	2
BSWAP dst	dst[7:0] ← dst[0:7]	R		D5	X	*	*	0	-	-	2	2
BTJ p, bit, src, dst	if src[bit]=p PC ← PC + X		r	F6	-	-	-	-	-	-	3	3
			lr	F7							3	4
BTJNZ bit, src, dst	if src[bit]=1 PC ← PC + X		r	F6	-	-	-	-	-	-	3	3
			lr	F7							3	4
BTJZ bit, src, dst	if src[bit]=0 PC ← PC + X		r	F6	-	-	-	-	-	-	3	3
			lr	F7							3	4
CALL dst	SP ← SP -2 @SP ← PC PC ← dst	IRR		D4	-	-	-	-	-	-	2	6
		DA		D6							3	3
CCF	C ← ~C			EF	*	-	-	-	-	-	1	2

Note: Flags notation:

*=Value is a function of the result of the operation.

-=Unaffected.

X=Undefined.

0=Reset to 0.

1=Set to 1.



Table 325. eZ8 CPU Instruction Summary (Continued)

Assembly Mnemonic	Symbolic Operation	Address Mode		Op Code(s) (Hex)	Flags						Fetch Cycles	Instr. Cycles
		dst	src		C	Z	S	V	D	H		
CLR dst	dst ← 00h	R		B0	-	-	-	-	-	-	2	2
		IR		B1								2
COM dst	dst ← ~dst	R		60	-	*	*	0	-	-	2	2
		IR		61								2
CP dst, src	dst – src	r	r	A2	*	*	*	*	-	-	2	3
		r	lr	A3							2	4
		R	R	A4							3	3
		R	IR	A5							3	4
		R	IM	A6							3	3
		IR	IM	A7							3	4
CPC dst, src	dst – src – C	r	r	1F A2	*	*	*	*	-	-	3	3
		r	lr	1F A3							3	4
		R	R	1F A4							4	3
		R	IR	1F A5							4	4
		R	IM	1F A6							4	3
		IR	IM	1F A7							4	4
CPCX dst, src	dst – src – C	ER	ER	1F A8	*	*	*	*	-	-	5	3
		ER	IM	1F A9							5	3
CPX dst, src	dst – src	ER	ER	A8	*	*	*	*	-	-	4	3
		ER	IM	A9							4	3
DA dst	dst ← DA(dst)	R		40	*	*	*	X	-	-	2	2
		IR		41							2	3
DEC dst	dst ← dst – 1	R		30	-	*	*	*	-	-	2	2
		IR		31							2	3
DECW dst	dst ← dst – 1	RR		80	-	*	*	*	-	-	2	5
		IRR		81							2	6
DI	IRQCTL[7] ← 0			8F	-	-	-	-	-	-	1	2

Note: Flags notation:
 *=Value is a function of the result of the operation.
 -=Unaffected.
 X=Undefined.
 0=Reset to 0.
 1=Set to 1.



Table 325. eZ8 CPU Instruction Summary (Continued)

Assembly Mnemonic	Symbolic Operation	Address Mode		Op Code(s) (Hex)	Flags						Fetch Cycles	Instr. Cycles
		dst	src		C	Z	S	V	D	H		
DJNZ dst, RA	dst ← dst – 1 if dst ≠ 0 PC ← PC + X	r		0A–FA	–	–	–	–	–	–	2	3
EI	IRQCTL[7] ← 1			9F	–	–	–	–	–	–	1	2
HALT	Halt Mode			7F	–	–	–	–	–	–	1	2
INC dst	dst ← dst + 1	R		20	–	*	*	–	–	–	2	2
		IR		21							2	3
		r		0E–FE							1	2
INCW dst	dst ← dst + 1	RR		A0	–	*	*	*	–	–	2	5
		IRR		A1							2	6
IRET	FLAGS ← @SP SP ← SP + 1 PC ← @SP SP ← SP + 2 IRQCTL[7] ← 1			BF	*	*	*	*	*	*	1	5
JP dst	PC ← dst	DA		8D	–	–	–	–	–	–	3	2
		IRR		C4							2	3
JP cc, dst	if cc is true, PC ← dst	DA		0D–FD	–	–	–	–	–	–	3	2
JR dst	PC ← PC + X	DA		8B	–	–	–	–	–	–	2	2
JR cc, dst	if cc is true, PC ← PC + X	DA		0B–FB	–	–	–	–	–	–	2	2

Note: Flags notation:
 *=Value is a function of the result of the operation.
 –=Unaffected.
 X=Undefined.
 0=Reset to 0.
 1=Set to 1.



Table 325. eZ8 CPU Instruction Summary (Continued)

Assembly Mnemonic	Symbolic Operation	Address Mode		Op Code(s) (Hex)	Flags						Fetch Cycles	Instr. Cycles
		dst	src		C	Z	S	V	D	H		
LD dst, rc	dst ← src	r	IM	0C–FC	–	–	–	–	–	–	2	2
		r	X(r)	C7							3	3
		X(r)	r	D7							3	4
		r	lr	E3							2	3
		R	R	E4							3	2
		R	IR	E5							3	4
		R	IM	E6							3	2
		IR	IM	E7							3	3
		lr	r	F3							2	3
		IR	R	F5							3	3
LDC dst, src	dst ← src	r	lrr	C2	–	–	–	–	–	–	2	5
		lr	lrr	C5							2	9
		lrr	r	D2							2	5
LDCI dst, src	dst ← src r ← r + 1 rr ← rr + 1	lr	lrr	C3	–	–	–	–	–	–	2	9
		lrr	lr	D3							2	9
LDE dst, src	dst ← src	r	lrr	82	–	–	–	–	–	–	2	5
		lrr	r	92							2	5
LDEI dst, src	dst ← src r ← r + 1 rr ← rr + 1	lr	lrr	83	–	–	–	–	–	–	2	9
		lrr	lr	93							2	9
LDWX dst, src	dst ← src	ER	ER	1FE8	–	–	–	–	–	–	5	4

Note: Flags notation:
 *=Value is a function of the result of the operation.
 –=Unaffected.
 X=Undefined.
 0=Reset to 0.
 1=Set to 1.

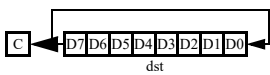

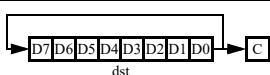



Table 325. eZ8 CPU Instruction Summary (Continued)

Assembly Mnemonic	Symbolic Operation	Address Mode		Op Code(s) (Hex)	Flags						Fetch Cycles	Instr. Cycles
		dst	src		C	Z	S	V	D	H		
LDX dst, src	dst ← src	r	ER	84	-	-	-	-	-	-	3	2
		lr	ER	85							3	3
		R	IRR	86							3	4
		IR	IRR	87							3	5
		r	X(rr)	88							3	4
		X(rr)	r	89							3	4
		ER	r	94							3	2
		ER	lr	95							3	3
		IRR	R	96							3	4
		IRR	IR	97							3	5
		ER	ER	E8							4	2
		ER	IM	E9							4	2
LEA dst, X(src)	dst ← src + X	r	X(r)	98	-	-	-	-	-	-	3	3
		rr	X(rr)	99							3	5
MULT dst	dst[15:0] ← dst[15:8] * dst[7:0]	RR		F4	-	-	-	-	-	-	2	8
NOP	No operation			0F	-	-	-	-	-	-	1	2
OR dst, src	dst ← dst OR src	r	r	42	-	*	*	0	-	-	2	3
		r	lr	43							2	4
		R	R	44							3	3
		R	IR	45							3	4
		R	IM	46							3	3
		IR	IM	47							3	4
ORX dst, src	dst ← dst OR src	ER	ER	48	-	*	*	0	-	-	4	3
		ER	IM	49							4	3
POP dst	dst ← @SP SP ← SP + 1	R		50	-	-	-	-	-	-	2	2
		IR		51							2	3



Note: Flags notation:
 *=Value is a function of the result of the operation.
 -=Unaffected.
 X=Undefined.
 0=Reset to 0.
 1=Set to 1.

Table 325. eZ8 CPU Instruction Summary (Continued)

Assembly Mnemonic	Symbolic Operation	Address Mode		Op Code(s) (Hex)	Flags						Fetch Cycles	Instr. Cycles
		dst	src		C	Z	S	V	D	H		
POPX dst	dst ← @SP SP ← SP + 1	ER		D8	-	-	-	-	-	-	3	2
PUSH src	SP ← SP - 1 @SP ← src	R		70	-	-	-	-	-	-	2	2
		IR		71							2	3
		IM		IF70							3	2
PUSHX src	SP ← SP - 1 @SP ← src	ER		C8	-	-	-	-	-	-	3	2
RCF	C ← 0			CF	0	-	-	-	-	-	1	2
RET	PC ← @SP SP ← SP + 2			AF	-	-	-	-	-	-	1	4
RL dst		R		90	*	*	*	*	-	-	2	2
		IR		91							2	3
RLC dst		R		10	*	*	*	*	-	-	2	2
		IR		11							2	3
RR dst		R		E0	*	*	*	*	-	-	2	2
		IR		E1							2	3
RRC dst		R		C0	*	*	*	*	-	-	2	2
		IR		C1							2	3
SBC dst, src	dst ← dst - src - C	r	r	32	*	*	*	*	1	*	2	3
		r	Ir	33							2	4
		R	R	34							3	3
		R	IR	35							3	4
		R	IM	36							3	3
		IR	IM	37							3	4
SBCX dst, src	dst ← dst - src - C	ER	ER	38	*	*	*	*	1	*	4	3
		ER	IM	39							4	3
SCF	C ← 1			DF	1	-	-	-	-	-	1	2

Note: Flags notation:
 *=Value is a function of the result of the operation.
 -=Unaffected.
 X=Undefined.
 0=Reset to 0.
 1=Set to 1.

Table 325. eZ8 CPU Instruction Summary (Continued)

Assembly Mnemonic	Symbolic Operation	Address Mode		Op Code(s) (Hex)	Flags						Fetch Cycles	Instr. Cycles
		dst	src		C	Z	S	V	D	H		
SRA dst		R		D0	*	*	*	0	-	-	2	2
		IR		D1							2	3
SRL dst		R		1F C0	*	*	0	*	-	-	3	2
		IR		1F C1							3	3
SRP src	RP ← src		IM	01	-	-	-	-	-	-	2	2
STOP	Stop Mode			6F	-	-	-	-	-	-	1	2
SUB dst, src	dst ← dst – src	r	r	22	*	*	*	*	1	*	2	3
		r	lr	23							2	4
		R	R	24							3	3
		R	IR	25							3	4
		R	IM	26							3	3
		IR	IM	27							3	4
SUBX dst, src	dst ← dst – src	ER	ER	28	*	*	*	*	1	*	4	3
		ER	IM	29							4	3
SWAP dst	dst[7:4] ↔ dst[3:0]	R		F0	X	*	*	X	-	-	2	2
		IR		F1							2	3
TCM dst, src	(NOT dst) AND src	r	r	62	-	*	*	0	-	-	2	3
		r	lr	63							2	4
		R	R	64							3	3
		R	IR	65							3	4
		R	IM	66							3	3
		IR	IM	67							3	4
TCMX dst, src	(NOT dst) AND src	ER	ER	68	-	*	*	0	-	-	4	3
		ER	IM	69							4	3

Note: Flags notation:
 *=Value is a function of the result of the operation.
 -=Unaffected.
 X=Undefined.
 0=Reset to 0.
 1=Set to 1.



Table 325. eZ8 CPU Instruction Summary (Continued)

Assembly Mnemonic	Symbolic Operation	Address Mode		Op Code(s) (Hex)	Flags						Fetch Cycles	Instr. Cycles
		dst	src		C	Z	S	V	D	H		
TM dst, src	dst AND src	r	r	72	-	*	*	0	-	-	2	3
		r	lr	73							2	4
		R	R	74							3	3
		R	IR	75							3	4
		R	IM	76							3	3
		IR	IM	77							3	4
TMX dst, src	dst AND src	ER	ER	78	-	*	*	0	-	-	4	3
		ER	IM	79							4	3
TRAP Vector	SP ← SP - 2 @SP ← PC SP ← SP - 1 @SP ← FLAGS PC ← @Vector		Vector	F2	-	-	-	-	-	-	2	6
WDT				5F	-	-	-	-	-	-	1	2
XOR dst, src	dst ← dst XOR src	r	r	B2	-	*	*	0	-	-	2	3
		r	lr	B3							2	4
		R	R	B4							3	3
		R	IR	B5							3	4
		R	IM	B6							3	3
		IR	IM	B7							3	4
XORX dst, src	dst ← dst XOR src	ER	ER	B8	-	*	*	0	-	-	4	3
		ER	IM	B9							4	3

Note: Flags notation:
 *=Value is a function of the result of the operation.
 -=Unaffected.
 X=Undefined.
 0=Reset to 0.
 1=Set to 1.

Chapter 32. Op Code Maps

Figure 103 shows a description of the op code map data and the abbreviations. Table 326 lists Op Code Map abbreviations.

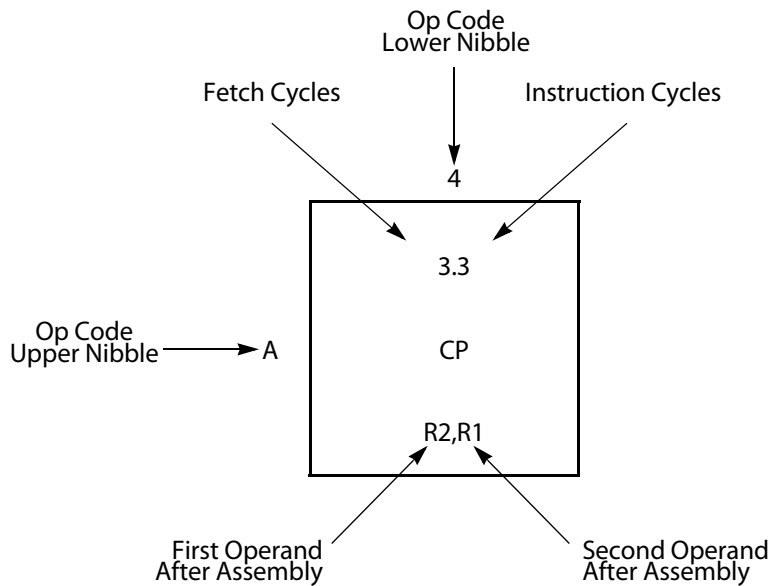

Figure 103. Op Code Map Cell Description

Table 326. Op Code Map Abbreviations

Abbreviation	Description	Abbreviation	Description
b	Bit position	IRR	Indirect Register Pair
cc	Condition code	p	Polarity (0 or 1)
X	8-bit signed index or displacement	r	4-bit Working Register
DA	Destination address	R	8-bit register
ER	Extended Addressing register	r1, R1, lr1, lrr1, IR1, rr1, RR1, IRR1, ER1	Destination address
IM	Immediate data value	r2, R2, lr2, lrr2, IR2, rr2, RR2, IRR2, ER2	Source address
lr	Indirect Working Register	RA	Relative
IR	Indirect register	rr	Working Register Pair
lrr	Indirect Working Register Pair	RR	Register Pair

Figures 104 and 105 provide information about each of the eZ8 CPU instructions.

		Lower Nibble (Hex)															
		0	1	2	3	4	5	6	7	8	9	A	B	C	D	E	F
Upper Nibble (Hex)	0	1.1 BRK	2.2 SRP IM	2.3 ADD r1,r2	2.4 ADD r1,lr2	3.3 ADD R2,R1	3.4 ADD IR2,R1	3.3 ADD R1,IM	3.4 ADD IR1,IM	4.3 ADDX ER2,ER1	4.3 ADDX IM,ER1	2.3 DJNZ r1,X	2.2 JR cc,X	2.2 LD r1,IM	3.2 JP cc,DA	1.2 INC r1	1.2 NOP
	1	2.2 RLC R1	2.3 RLC IR1	2.3 ADC r1,r2	2.4 ADC r1,lr2	3.3 ADC R2,R1	3.4 ADC IR2,R1	3.3 ADC R1,IM	3.4 ADC IR1,IM	4.3 ADCX ER2,ER1	4.3 ADCX IM,ER1						See 2nd Op Code Map
	2	2.2 INC R1	2.3 INC IR1	2.3 SUB r1,r2	2.4 SUB r1,lr2	3.3 SUB R2,R1	3.4 SUB IR2,R1	3.3 SUB R1,IM	3.4 SUB IR1,IM	4.3 SUBX ER2,ER1	4.3 SUBX IM,ER1						1, 2 ATM
	3	2.2 DEC R1	2.3 DEC IR1	2.3 SBC r1,r2	2.4 SBC r1,lr2	3.3 SBC R2,R1	3.4 SBC IR2,R1	3.3 SBC R1,IM	3.4 SBC IR1,IM	4.3 SBCX ER2,ER1	4.3 SBCX IM,ER1						
	4	2.2 DA R1	2.3 DA IR1	2.3 OR r1,r2	2.4 OR r1,lr2	3.3 OR R2,R1	3.4 OR IR2,R1	3.3 OR R1,IM	3.4 OR IR1,IM	4.3 ORX ER2,ER1	4.3 ORX IM,ER1						
	5	2.2 POP R1	2.3 POP IR1	2.3 AND r1,r2	2.4 AND r1,lr2	3.3 AND R2,R1	3.4 AND IR2,R1	3.3 AND R1,IM	3.4 AND IR1,IM	4.3 ANDX ER2,ER1	4.3 ANDX IM,ER1						1.2 WDT
	6	2.2 COM R1	2.3 COM IR1	2.3 TCM r1,r2	2.4 TCM r1,lr2	3.3 TCM R2,R1	3.4 TCM IR2,R1	3.3 TCM R1,IM	3.4 TCM IR1,IM	4.3 TCMX ER2,ER1	4.3 TCMX IM,ER1						1.2 STOP
	7	2.2 PUSH R2	2.3 PUSH IR2	2.3 TM r1,r2	2.4 TM r1,lr2	3.3 TM R2,R1	3.4 TM IR2,R1	3.3 TM R1,IM	3.4 TM IR1,IM	4.3 TMX ER2,ER1	4.3 TMX IM,ER1						1.2 HALT
	8	2.5 DECW RR1	2.6 DECW IRR1	2.5 LDE r1,lr2	2.9 LDEI lr1,lr2	3.2 LDX r1,ER2	3.3 LDX lr1,ER2	3.4 LDX IRR2,R1	3.5 LDX IRR2,IR1	3.4 LDX r1,rr2,X	3.4 LDX rr1,rr2,X						1.2 DI
	9	2.2 RL R1	2.3 RL IR1	2.5 LDE r2,lr1	2.9 LDEI lr2,lr1	3.2 LDX r2,ER1	3.3 LDX lr2,ER1	3.4 LDX R2,IRR1	3.5 LDX IR2,IRR1	3.3 LEA r1,r2,X	3.5 LEA rr1,rr2,X						1.2 EI
	A	2.5 INCW RR1	2.6 INCW IRR1	2.3 CP r1,r2	2.4 CP r1,lr2	3.3 CP R2,R1	3.4 CP IR2,R1	3.3 CP R1,IM	3.4 CP IR1,IM	4.3 CPX ER2,ER1	4.3 CPX IM,ER1						1.4 RET
	B	2.2 CLR R1	2.3 CLR IR1	2.3 XOR r1,r2	2.4 XOR r1,lr2	3.3 XOR R2,R1	3.4 XOR IR2,R1	3.3 XOR R1,IM	3.4 XOR IR1,IM	4.3 XORX ER2,ER1	4.3 XORX IM,ER1						1.5 IRET
	C	2.2 RRC R1	2.3 RRC IR1	2.5 LDC r1,lr2	2.9 LDCI lr1,lr2	2.3 JP IRR1	2.9 LDC lr1,lr2		3.4 LD r1,r2,X	3.2 PUSHX ER2							1.2 RCF
	D	2.2 SRA R1	2.3 SRA IR1	2.5 LDC r2,lr1	2.9 LDCI lr2,lr1	2.6 CALL IRR1	2.2 BSWAP R1	3.3 CALL DA	3.4 LD r2,r1,X	3.2 POPX ER1							1.2 SCF
	E	2.2 RR R1	2.3 RR IR1	2.2 BIT p,b,r1	2.3 LD r1,lr2	3.2 LD R2,R1	3.3 LD IR2,R1	3.2 LD R1,IM	3.3 LD IR1,IM	4.2 LDX ER2,ER1	4.2 LDX IM,ER1						1.2 CCF
	F	2.2 SWAP R1	2.3 SWAP IR1	2.6 TRAP Vector	2.3 LD lr1,r2	2.8 MULT RR1	3.3 LD R2,IR1	3.3 BTJ p,b,r1,X	3.4 BTJ p,b,lr1,X								

Figure 104. First Op Code Map

		Lower Nibble (Hex)															
		0	1	2	3	4	5	6	7	8	9	A	B	C	D	E	F
Upper Nibble (Hex)	0																
	1																
	2																
	3																
	4																
	5																
	6																
	7																
	8																
	9																
	A			3.3 CPC r1,r2	3.4 CPC r1,lr2	4.3 CPC R2,R1	4.4 CPC IR2,R1	4.3 CPC R1,IM	4.4 CPC IR1,IM	5.3 CPCX ER2,ER1	5.3 CPCX IM,ER1						
	B																
	C		3.2 SRL R1	3.3 SRL IR1													
	D																
	E										5.4 LDWX ER2,ER1						
	F																

Figure 105. Second Op Code Map after 1Fh

Chapter 33. Electrical Characteristics

The data in this chapter has been tabulated prior to qualification (i.e., prequalification) and precharacterization of the F6482 Series product, and is subject to change. Additional electrical characteristics can be found in the individual chapters of this document.

33.1. Absolute Maximum Ratings

Stresses greater than those listed in Table 327 can cause permanent damage to the device. These ratings are stress ratings only. Operation of the device at any condition outside those indicated in the operational sections of these specifications is not implied. Exposure to absolute maximum rating conditions for extended periods can affect device reliability. For improved reliability, tie unused inputs to one of the supply voltages (V_{DD} or V_{SS}).

Table 327. Absolute Maximum Ratings*

Parameter	Min	Max	Units
Ambient temperature under bias	-40	+125	°C
Storage temperature	-65	+150	°C
Voltage on any pin with respect to V_{SS}	-0.3	+4.0	V
Maximum current on input and/or inactive output pin	-5	+5	μ A
Maximum output current from active output pin	-25	+25	mA
28-pin Packages Maximum Ratings at -40°C to 85°C			
Total power dissipation		-	mW
Maximum current into V_{DD} or out of V_{SS}		-	mA
32-Pin QFN Maximum Ratings at -40°C to 85°C			
Total power dissipation		-	mW
Maximum current into V_{DD} or out of V_{SS}		-	mA
44-Pin LQFP Maximum Ratings at -40°C to 85°C			
Total power dissipation		-	mW
Maximum current into V_{DD} or out of V_{SS}		-	mA
64-pin LQFP Maximum Ratings at -40°C to 85°C			
Total power dissipation		-	mW
Maximum current into V_{DD} or out of V_{SS}		-	mA

Note: *Operating temperature is specified in the DC Characteristics section.

Table 327. Absolute Maximum Ratings* (Continued)

Parameter (Continued)	Min	Max	Units
80-pin LQFP Maximum Ratings at –40°C to 85°C			
Total power dissipation		–	mW
Maximum current into V_{DD} or out of V_{SS}		–	mA
Note: *Operating temperature is specified in the DC Characteristics section.			

33.2. DC Characteristics

Table 328 lists the DC characteristics of the F6482 Series products. All voltages are referenced to V_{SS} , which is the primary system ground.

Table 328. DC Characteristics

Symbol	Parameter	$T_A = -40^\circ\text{C to } +85^\circ\text{C}$			Units	Conditions
		Min	Typical ¹	Max		
V_{DD}	Supply Voltage	1.8		3.6	V	
V_{IL1}	Low Level Input Voltage	–0.3		$0.3 \cdot V_{DD}$	V	For all input pins except X_{IN} , $X2_{IN}$
V_{IL2}	Low Level Input Voltage	–0.3		–	V	For X_{IN} , $X2_{IN}$
V_{IH1}	High Level Input Voltage	$0.7 \cdot V_{DD}$		$V_{DD} + 0.3$	V	All input pins
V_{OL1}	Low Level Output Voltage			0.4	V	$I_{OL} = 2 \text{ mA}$; $V_{DD} = 3.0\text{V}$ High Output Drive disabled.
V_{OH1}	High Level Output Voltage	$V_{DD} - 0.5$			V	$I_{OH} = -2 \text{ mA}$; $V_{DD} = 3.0\text{V}$ High Output Drive disabled.
V_{OL2}	Low Level Output Voltage	–		0.4	V	$I_{OL} = 8 \text{ mA}$; $V_{DD} = 3.0\text{V}$ High Output Drive enabled.
V_{OH2}	High Level Output Voltage	$V_{DD} - 0.5$			V	$I_{OH} = -8 \text{ mA}$; $V_{DD} = 3.0\text{V}$ High Output Drive enabled.
I_{IL}	Input Leakage Current	–50		+50	nA	$V_{DD} = 3.6\text{V}$; $V_{IN} = V_{DD}$ or V_{SS} ²
I_{TL}	Tristate Leakage Current	–50		+50	nA	$V_{DD} = 3.6\text{V}$

Notes:

1. These values are provided for design guidance only and are not tested in production.
2. This condition excludes all pins that have on-chip pull-ups, when driven Low.

Table 328. DC Characteristics (Continued)

Symbol	Parameter	$T_A = -40^\circ\text{C to } +85^\circ\text{C}$			Units	Conditions
		Min	Typical ¹	Max		
C_{PAD}	GPIO Port Pad Capacitance		≤8.0		pF	
C_{XIN}	X_{IN} Pad Capacitance		≤8.0		pF	
C_{XOUT}	X_{OUT} Pad Capacitance		≤9.5		pF	
I_{PU}	Weak Pull-up Current	60	100	140	μA	$V_{DD} = 3.3\text{V}$

Notes:

1. These values are provided for design guidance only and are not tested in production.
2. This condition excludes all pins that have on-chip pull-ups, when driven Low.

The currents in Table 329 represent the power consumption without any peripherals active (unless otherwise noted). For design guidance, total power consumption will be the sum of all active peripheral currents plus the appropriate current characteristics shown below.

Table 329. Supply Current Characteristics

Symbol	Parameter	$T_A = -40^\circ\text{C to } +85^\circ\text{C}$			Units	Conditions ²
		Min	Typical ¹	Max		
I_{DDA}	Active Mode Device Current		5		mA	20MHz ^{3,4,5,6}
			2.1		mA	8 MHz ^{3,4,5,6}
			0.3		mA	1 MHz ^{3,4,5,6}
			0.02		mA	32kHz ^{3,4,5,6}
I_{DDH}	Halt Mode Device Current		3		mA	20MHz ^{3,4,5}
			1.3		mA	8MHz ^{3,4,5,6}
			0.2		mA	1MHz ^{3,4,5,6}
			0.02		mA	32kHz ^{3,4,5,6}

Notes:

1. These values are provided for design guidance only and are not tested in production.
2. Typical conditions are defined as 3.0V at 25°C, unless otherwise noted.
3. All internal pull ups are disabled and all push-pull outputs are unloaded.
4. All open-drain outputs are pulled up to V_{DD}/AV_{DD} and are at a High state.
5. System clock source is an external square wave clock signal driven through the CLKIN pin.
6. All inputs are at V_{DD}/AV_{DD} or V_{SS}/AV_{SS} as appropriate.

Table 329. Supply Current Characteristics (Continued)

Symbol	Parameter	$T_A = -40^\circ\text{C to } +85^\circ\text{C}$			Units	Conditions ²
		Min	Typical ¹	Max		
I_{DDS1}	Stop Mode Device Current with FRECOV = 1		2.9		μA	All peripherals disabled including VBO and WDT ^{3,4,6}
I_{DDS2}	Stop Mode Device Current with FRECOV = 0		0.7		μA	All peripherals disabled including VBO and WDT ^{3,4,6}

Notes:

1. These values are provided for design guidance only and are not tested in production.
2. Typical conditions are defined as 3.0V at 25°C, unless otherwise noted.
3. All internal pull ups are disabled and all push-pull outputs are unloaded.
4. All open-drain outputs are pulled up to $V_{\text{DD}}/AV_{\text{DD}}$ and are at a High state.
5. System clock source is an external square wave clock signal driven through the CLKIN pin.
6. All inputs are at $V_{\text{DD}}/AV_{\text{DD}}$ or $V_{\text{SS}}/AV_{\text{SS}}$ as appropriate.

33.3. AC Characteristics

Table 330 lists the AC characteristics and timing of the F6482 Series products. All AC timing information assumes a standard load of 50pF on all outputs.

Table 330. AC Characteristics

Symbol	Parameter	$V_{\text{DD}} = 1.8 \text{ to } 3.6\text{V}$ $T_A = -40^\circ\text{C to } +85^\circ\text{C}$			Units	Conditions
		Min	Typ	Max		
F_{SYSCLK}	System Clock Frequency			24	MHz	See Figure 106
T_{XIN}	CLKIN Period	41.66			ns	$T_{\text{CLK}} = 1/F_{\text{SYSCLK}}$
T_{XINH}	CLKIN High Time	16.66		25	ns	$T_{\text{CLK}} = 41.66 \text{ ns}$
T_{XINL}	CLKIN Low Time	16.66		25	ns	$T_{\text{CLK}} = 41.66 \text{ ns}$
T_{XINR}	CLKIN Rise Time			3	ns	$T_{\text{CLK}} = 41.66 \text{ ns}$
T_{XINF}	CLKIN Fall Time			3	ns	$T_{\text{CLK}} = 41.66 \text{ ns}$
T_{XIN2}	CLK2IN Period		30.5		μs	$T_{\text{CLK}} = 1/F_{\text{PCLK}}$
F_{PCLK}	Peripheral Clock Frequency		32.768		kHz	

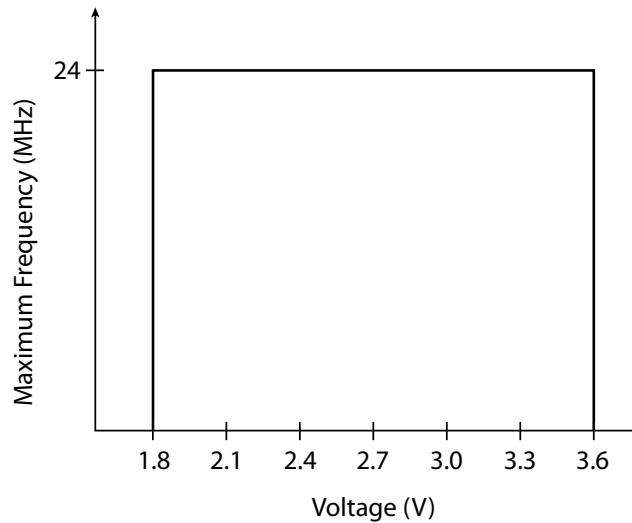

Figure 106. Maximum System Clock Frequency vs. V_{DD}

33.4. On-Chip Peripheral AC and DC Electrical Characteristics

On-chip peripheral AC and DC electrical characteristics are listed in [Tables 331 through 339](#).

33.4.1. Power-On Reset

Table 331 presents electrical and timing data for the F6482 Series' Power-On Reset function.

Table 331. Power-On Reset Electrical Characteristics and Timing

Symbol	Parameter	T _A = -40°C to +85°C			Units	Conditions
		Min	Typ*	Max		
I _{DDPOR}	POR Active Current		<0.01		μA	
V _{POR}	Power-On Reset Voltage Threshold	1.30	1.55	1.75	V	V _{DD} = V _{POR}
V _{TH}	POR Start Voltage		0.6		V	
T _{RAMP}	V _{DD} Ramp Up Time	0.01		1000	ms	

Note: *Data in the Typical column is from characterization at 3.0V and 25°C. These values are provided for design guidance only and are not tested in production.

33.4.2. Voltage Brown-Out

Table 332 presents electrical and timing data for the F6482 Series' Voltage Brown-Out function.

Table 332. Voltage Brown-Out Electrical Characteristics and Timing

Symbol	Parameter	T _A = -40°C to +85°C			Units	Conditions
		Min	Typ*	Max		
I _{DDVBO}	VBO Active Current		2		μA	Normal and Halt modes
			0.07		μA	Stop Mode
V _{VBO}	Voltage Brown-Out Reset Voltage Threshold	1.8	1.85	1.9	V	V _{DD} = V _{VBO}
V _{HYS}	Hysteresis of V _{VBO}		100		mV	
T _{RESET}	Reset Delay		10		ms	V _{DD} > V _{POR} , V _{DD} > V _{VBO}

Note: *Data in the Typical column is from characterization at 3.0V and 25°C. These values are provided for design guidance only and are not tested in production.

33.4.3. Stop-Mode Recovery

Table 333 presents electrical and timing data for the F6482 Series' Stop-Mode Recovery function.

Table 333. Stop-Mode Recovery (SMR) Timing

Symbol	Parameter	T _A = -40°C to +85°C			Units	Conditions
		Min	Typ*	Max		
T _{SMRD}	Stop-Mode Recovery Latency		6 SYSCLKs			FRECOV=0
			+ T _{SMRD}			
			6 SYSCLKs			FRECOV=1
T _{SMRD}	Stop-Mode Recovery Delay		300		μs	

Note: *Data in the Typical column is from characterization at 3.0V and 25°C. These values are provided for design guidance only and are not tested in production.

33.4.4. Flash Memory

Table 334 presents electrical and timing data for the F6482 Series' Flash Memory function.

Table 334. Flash Memory Electrical Characteristics and Timing

Parameter	$V_{DD}=1.8V$ to $3.6V$ $T_A=-40^{\circ}C$ to $+85^{\circ}C$			Units	Conditions
	Min	Typ	Max		
Program Current			7	mA	
Erase Current			7	mA	
DCOCLK Frequency for Program or Erasure of Flash Memory	1		24	MHz	FLL locked
Flash Byte or Word Program Time	20		40	μs	
Flash Page Erase Time	20		40	ms	
Flash Mass Erase Time	20		40	ms	
Writes to Single Address Before Next Erase			2		
Cumulative Program Time*			8	ms	
Data Retention	100			years	$25^{\circ}C$
Endurance	10,000			cycles	Program/erase cycles

Note: *Cumulative Program Time pertains to each (128-byte) row in a page. See the [Flash Memory](#) chapter on page 529 to learn more.

33.4.5. Watchdog Timer

Table 335 presents electrical and timing data for the F6482 Series' Watchdog Timer function.

Table 335. Watchdog Timer Electrical Characteristics and Timing

Symbol	Parameter	$V_{DD}=1.8V$ to $3.6V$ $T_A=-40^{\circ}C$ to $+85^{\circ}C$			Unit	Conditions
		Min	Typ*	Max		
I_{DDWDT}	WDT Active Current		0.15	–	μA	
F_{WDT}	WDT Oscillator Frequency	5	10	15	kHz	

Note: *Data in the Typical column is from characterization at 3.0V and $25^{\circ}C$. These values are provided for design guidance only and are not tested in production.

33.4.6. Non-Volatile Data Storage

Table 336 presents electrical and timing data for the F6482 Series' Non-Volatile Data Storage function.

Table 336. Non-Volatile Data Storage Electrical Characteristics and Timing

Parameter	$V_{DD}=1.8V$ to $3.6V$ $T_A=-40^{\circ}C$ to $+85^{\circ}C$			Units	Conditions
	Min	Typ	Max		
NVDS Byte Read Time	34		519	μs	With system clock at 20MHz
NVDS Byte Program Time	0.171		39.7	ms	With system clock at 20MHz
Data Retention	100		–	years	$25^{\circ}C$
Endurance	100,000			cycles	Cumulative write cycles for entire memory

33.4.7. Analog-to-Digital Converter

Table 337 presents electrical and timing data for the F6482 Series' Analog-to-Digital Converter function.

Table 337. Analog-to-Digital Converter Electrical Characteristics and Timing

Symbol	Parameter	$V_{DD}=1.8V$ to $3.6V$ $T_A=-40^{\circ}C$ to $+85^{\circ}C$			Units	Conditions
		Min	Typ ¹	Max		
N	Resolution			12	Bit	RESOLUT=0 (12-bit)
				14	Bit	RESOLUT=1 (2-pass 14-bit)
INL	Integral Nonlinearity			± 2	LSB	RESOLUT=0
				± 5	LSB	RESOLUT=1, INMODE=01
DNL	Differential Nonlinearity			$\leq \pm 1$	LSB	No missing codes RESOLUT=0
				$\leq \pm 2$	LSB	RESOLUT=1, INMODE=01

Notes:

1. Data in the Typical column is from characterization at 3.0V and $25^{\circ}C$. These values are provided for design guidance only and are not tested in production.
2. T_S is applied twice if INMODE=10 and RESOLUT=1.
3. T_{SS} is applied twice if RESOLUT=1.

Table 337. Analog-to-Digital Converter Electrical Characteristics and Timing (Continued)

Symbol	Parameter	$V_{DD}=1.8V$ to $3.6V$ $T_A=-40^{\circ}C$ to $+85^{\circ}C$			Units	Conditions
		Min	Typ ¹	Max		
	Gain Error			± 4	LSB	RESOLUT=0, No gain calibration run
				–	LSB	RESOLUT=0, Gain calibration run
				± 16	LSB	RESOLUT=1, No gain calibration run
				–	LSB	RESOLUT=1, Gain calibration run
	Offset Error			± 3	LSB	RESOLUT=0, No offset calibration run
				± 1	LSB	RESOLUT=0, Offset calibration run
				± 12	LSB	RESOLUT=1, No offset calibration run
				–	LSB	RESOLUT=1, Offset calibration run
$I_{DD}ADCI$	ADC Active Current with Internal Reference (REFSEL=1x)		180		μA	INMODE=0x, POWER=00
			230		μA	INMODE=1x, POWER=00
			95		μA	INMODE=0x, POWER=10
			115		μA	INMODE=1x, POWER=10
$I_{DD}ADCE$	ADC Active Current with External Reference or V_{DD} Reference (REFSEL=0x) including $I_{DD}VEXT$		155		μA	INMODE=0x, POWER=00
			205		μA	INMODE=1x, POWER=00
			85		μA	INMODE=0x, POWER=10
			105		μA	INMODE=1x, POWER=10

Notes:

1. Data in the Typical column is from characterization at 3.0V and 25°C. These values are provided for design guidance only and are not tested in production.
2. T_S is applied twice if INMODE=10 and RESOLUT=1.
3. T_{SS} is applied twice if RESOLUT=1.

Table 337. Analog-to-Digital Converter Electrical Characteristics and Timing (Continued)

		V _{DD} =1.8V to 3.6V T _A =-40°C to +85°C				
Symbol	Parameter	Min	Typ ¹	Max	Units	Conditions
V _{INT_REF}	Internal Reference Voltage	-1.5%	1.25	+1.5%	V	REFSEL=1x, REFLVL=00, AV _{DD} ≥ 1.8V
		-1.5%	1.50	+1.5%	V	REFSEL=1x, REFLVL=01, AV _{DD} ≥ 2.0V
		-1.5%	2.0	+1.5%	V	REFSEL=1x, REFLVL=10, AV _{DD} ≥ 2.5V
		-1.5%	2.5	+1.5%	V	REFSEL=1x, REFLVL=11, AV _{DD} ≥ 3.0V
			AV _{DD}			
V _{EXT_REFP}	External Positive Reference Voltage	1.25		AV _{DD}	V	REFSEL=01, INMODE=0x
		1.25		AV _{DD} -0.5V	V	REFSEL=01, INMODE=1x
V _{EXT_REFN}	External Negative Reference Voltage	AV _{SS}	AV _{SS}	VREFP - 1.25V	V	
IDDVEXT	External Reference Active Current (included in IDDADCE)	20	40	55	µa	
C _{VREF}	V _{REF} Capacitance		1		µF	
V _{INANA}	Analog Input Range	VREFN		VREFP	V	
C _{IN}	Analog Input Capacitance			5	pF	
R _{IN}	Analog Input Resistance		750	2000	Ω	
T _S	Sampling Time ²	0.2			µs	INMODE=0x
		0.8			µs	INMODE=1x; POWER=00
		2.0			µs	INMODE=1x; POWER=10
T _{S_TSENSE}	Sampling Time ² for Temperature Sensor		24		µs	
T _{S_VDD/2}	Sampling Time ² for V _{DD} /2 Fixed Reference		24		µs	

Notes:

1. Data in the Typical column is from characterization at 3.0V and 25°C. These values are provided for design guidance only and are not tested in production.
2. T_S is applied twice if INMODE=10 and RESOLUT=1.
3. T_{SS} is applied twice if RESOLUT=1.

Table 337. Analog-to-Digital Converter Electrical Characteristics and Timing (Continued)

Symbol	Parameter	V _{DD} =1.8V to 3.6V T _A =-40°C to +85°C			Units	Conditions
		Min	Typ ¹	Max		
T _{SS}	Sample Settling Time ³	0.4			μs	INMODE=0x
		0.8			μs	INMODE=1x, POWER=00 12-bit (RESOLUT=0)
		3.0			μs	INMODE=1x, POWER=10
		1.0			μs	INMODE=1x, POWER=00 14-bit (RESOLUT=1)
T _{CONV}	Conversion Time		13		ADC clock cycles	12-bit (RESOLUT=0)
			30		ADC clock cycles	14-bit (RESOLUT=1)
T _{WAKE_AR}	Time for Wake up, Internal ADC Reference Buffer			T _{WAKE_} ADC	ADC clock cycles	REFSEL = 10
			0.5	1.1	ms	REFSEL = 11 C _{VREFP} = 1 μF
T _{WAKE_ADC}	Time for Wake up, ADC		30		ADC clock cycles	ADCREF = 0
f _{ADC_CLK}	Frequency of ADC clock			2	MHz	12-bit (RESOLUT=0); INMODE=0x; POWER=00
				5	MHz	12-bit (RESOLUT=0); INMODE=1x; POWER=00
				2	MHz	14-bit (RESOLUT=1); POWER=00
				1	MHz	12-bit (RESOLUT=0); POWER=10
				0.8	MHz	14-bit (RESOLUT=1); POWER=10

Notes:

1. Data in the Typical column is from characterization at 3.0V and 25°C. These values are provided for design guidance only and are not tested in production.
2. T_S is applied twice if INMODE=10 and RESOLUT=1.
3. T_{SS} is applied twice if RESOLUT=1.

33.4.8. Digital-to-Analog Converter

Table 338 presents electrical and timing data for the F6482 Series' Digital-to-Analog Converter function.

Table 338. Digital-to-Analog Converter Electrical Characteristics and Timing

Symbol	Parameter	$V_{DD}=1.8V$ to $3.6V$ $T_A=-40^{\circ}C$ to $+85^{\circ}C$			Units	Conditions
		Min	Typ*	Max		
N	Resolution			12	Bit	
INL	Integral Nonlinearity			± 4	LSB	
DNL	Differential Nonlinearity			$\leq \pm 1$	LSB	
	Gain Error			$\pm 1\%$	FSR	
	Offset Error			± 2	mV	
I_{DDDAC}	DAC Active Current		190	265	μA	POWER=00
			70	110	μA	POWER=01
			32	55	μA	POWER=10
V_{INT_REF}	Internal Reference Voltage	-1.5%	1.25	+1.5%	V	REFSEL=100, $AV_{DD} \geq 1.8V$
		-1.5%	1.50	+1.5%	V	REFSEL=101, $AV_{DD} \geq 2.0V$
		-1.5%	2.0	+1.5%	V	REFSEL=110, $AV_{DD} \geq 2.5V$
		-1.5%	2.5	+1.5%	V	REFSEL=111, $AV_{DD} \geq 3.0V$
			AV_{DD}			
I_{DDVINT}	Internal Reference Active Current		9	12	μA	REFSEL=1xx, POWER=00
V_{EXT_REFP}	External Positive Reference Voltage	1.25^2	-	AV_{DD}	V	REFSEL=011.
V_{EXT_REFN}	External Negative Reference Voltage	AV_{SS}		1.25	V	$V_{REFP}-V_{REFN} \geq 1.25V$
C_{VREF}	V_{REF} Capacitance		1		μF	
C_{LOAD}	DAC Maximum Load Capacitance			100	pF	
I_{OUT}	Maximum Load Current	-1		1	mA	

Note: *Data in the Typical column is from characterization at 3.0V and 25°C. These values are provided for design guidance only and are not tested in production.

Table 338. Digital-to-Analog Converter Electrical Characteristics and Timing (Continued)

		$V_{DD}=1.8V$ to $3.6V$ $T_A=-40^{\circ}C$ to $+85^{\circ}C$				
Symbol	Parameter	Min	Typ*	Max	Units	Conditions
R_{OUT}	Output Resistance		25	75	Ω	$V_{SS} \leq V_{DACOUT} \leq V_{DD}$
				3	Ω	$V_{SS}+0.3V \leq V_{DACOUT} \leq V_{DD}-0.3V$
V_{DAC}	DAC Output Voltage Range	$AV_{SS}+0$.1V		$AV_{DD}-0$.1V	V	
T_{SET_FS}	Settling Time, full scale		15		μs	POWER=00
			40		μs	POWER=01
			100		μs	POWER=10
T_{SET_CC}	Settling Time, code to code (adjacent codes)		1		μs	POWER=00
			2		μs	POWER=01
			5		μs	POWER=10
SR	Slew Rate		5		V/ μs	POWER=00
			1.4		V/ μs	POWER=01
			0.35		V/ μs	POWER=10
T_{UP}	Update rate			1	μs	
T_{WAKE_DR}	Time for Wake up, Internal DAC Reference		0.5	1.1	ms	$C_{VREFP}=1\mu F$
T_{WAKE_DAC}	Time for Wake up, DAC		18		μs	POWER=00
			25		μs	POWER=01
			35		μs	POWER=10

Note: *Data in the Typical column is from characterization at 3.0V and 25°C. These values are provided for design guidance only and are not tested in production.

33.4.9. Comparator

Table 339 presents electrical and timing data for the F6482 Series' Comparator function.

Table 339. Comparator Electrical Characteristics

		$T_A = -40^{\circ}\text{C to } +85^{\circ}\text{C}$				
		$V_{DD} = 1.8\text{V to } 3.6\text{V}$				
Symbol	Parameter	Min	Typ ¹	Max	Units	Conditions
I_{DDCOMP}	Comparator Active Current		0.2		μA	CPOWER=00
			1		μA	CPOWER=01
			4		μA	CPOWER=10
			27		μA	CPOWER=11
V_{ICM}	Input Common Mode Voltage	V_{SS}		V_{DD}	V	
V_{OS}	Input DC Offset		± 2	± 5	mV	
V_{HYS}^2	Input Hysteresis		0		mV	HYST=0x
			15		mV	HYST=10
			40		mV	HYST=11
T_{PROP}	Propagation Delay		5		μs	CPOWER=00
			1.5		μs	CPOWER=01
			700		ns	CPOWER=10
			150		ns	CPOWER=11
T_{WAKE}	Time for Wake up		2	5	μs	

Notes:

1. Data in the Typical column is from characterization at 3.0V and 25°C. These values are provided for design guidance only and are not tested in production.
2. Hysteresis is defined as overdrive of one input relative to the other to cause output transition, thus is half of the full hysteresis band.

33.4.10. Reference System

Table 340 presents electrical and timing data for the F6482 Series' Reference System.

Table 340. Reference System Electrical Characteristics

Symbol	Parameter	$T_A = -40^\circ\text{C to } +85^\circ\text{C}$			Units	Conditions
		$V_{DD} = 1.8\text{V to } 3.6\text{V}$				
		Min	Typ ¹	Max		
V_{PREF}	Programmable Internal Reference Voltage Range	VBIAS/32		VBIAS	V	PREFSRC=0
		$V_{DD}/32$		V_{DD}	V	PREFSRC=1
$V_{PREFTOL}$	Programmable Internal Reference Voltage Tolerance	Larger of -1.5% or -5mV	V_{PREF} ²	Larger of 1.5% or 5mV		PREFSRC=0 (VBIAS is source)
		Larger of -0.5% or -5mV	V_{PREF} ²	Larger of 0.5% or 5mV		PREFSRC=1 (AV_{DD} is source)
V_{FREF}	Fixed Internal Reference Voltage	-1.5%	0.75	+1.5%	V	0.75V fixed reference
		-1.5%	1.0	+1.5%	V	1.0V fixed reference
		-1.5%	1.25	+1.5%	V	1.25V fixed reference
		-1.5%	1.22	+1.5%	V	Bandgap voltage
		-0.5%	$V_{DD}/2$	+0.5%	V	$V_{DD}/2$ fixed reference
V_{VBIAS}	VBIAS Reference Voltage	-1.5%	1.25	+1.5%	V	VREFLVL=00
		-1.5%	1.50	+1.5%	V	VREFLVL=01
		-1.5%	2.00	+1.5%	V	VREFLVL=10
		-1.5%	2.50	+1.5%	V	VREFLVL=11
I_{VBIAS}	VBIAS Active Current		2		μA	
I_{VBIAS_OUT}	VBIAS Sourced Reference Current	-20		0	μA	
I_{PROG}	Programmable Reference Active Current		1.5		μA	

Notes:

1. Data in the Typical column is from characterization at 3.0V and 25°C. These values are provided for design guidance only and are not tested in production.
2. V_{PREF} is a user-set programmable reference voltage. See Tables 259 and 261 in the [Comparators and Reference System](#) chapter on page 486.

Table 340. Reference System Electrical Characteristics (Continued)

		$T_A = -40^\circ\text{C to } +85^\circ\text{C}$				
		$V_{DD} = 1.8\text{V to } 3.6\text{V}$				
Symbol	Parameter	Min	Typ ¹	Max	Units	Conditions
T_{WAKEF}	Time for Wake up, fixed references		2	5	μs	Upon selection of a fixed reference
T_{WAKEP}	Time for Wake up, VBIAS or programmable internal references			2	ms	Upon enable of VBIAS or Programmable Internal Reference

Notes:

1. Data in the Typical column is from characterization at 3.0V and 25°C. These values are provided for design guidance only and are not tested in production.
2. V_{PREF} is a user-set programmable reference voltage. See Tables 259 and [261](#) in the [Comparators and Reference System](#) chapter on page 486.

33.4.11. Temperature Sensor

Table 341 presents electrical and timing data for the F6482 Series' Temperature Sensor function.

Table 341. Temperature Sensor Electrical Characteristics

		$T_A = -40^\circ\text{C to } +85^\circ\text{C}$				
		$V_{DD} = 1.8 \text{ to } 3.6\text{V}$				
Symbol	Parameter	Min	Typ*	Max	Units	Conditions
I_{DDTEMP}	Temperature Sensor Active Current			15	μA	
T_{AERR}	Temperature Sensor Output Error	-4		+4	$^\circ\text{C}$	-40°C to +85°C (as measured by ADC)
		-1.5		+1.5	$^\circ\text{C}$	+20°C to +30°C (as measured by ADC)
T_{WAKE}	Time for Wake up		0.9	2	ms	

Note: *Data in the Typical column is from characterization at 3.0V and 25°C. These values are provided for design guidance only and are not tested in production.

33.4.12. Operational Amplifier

Table 342 presents electrical and timing data for the F6482 Series' Operational Amplifier function.

Table 342. Operational Amplifier Electrical Characteristics

Symbol	Parameter	$T_A = -40^\circ\text{C to } +85^\circ\text{C}$			Units	Conditions
		Min	Typ*	Max		
I _{DD} OA	Op Amp Active Current		1		μA	OPOWER=0 (low power)
			32		μA	OPOWER=1 (normal power)
V _{ICM}	Input Common Mode Voltage	V _{SS}		V _{DD}	V	All except Op Amp B with MODE=1
		V _{SS}		V _{DD} -1V	V	Op Amp B with MODE=1
V _{OS}	Input Offset Voltage	-8		8	mV	
V _{OSTA}	Input Offset Temperature Drift	-	1	10	μV/°C	
V _{OCM}	Output Common Mode Voltage	V _{SS}		V _{DD}	V	
A _V	DC Gain		72		dB	OPOWER=0
			98		dB	OPOWER=1
PM	Phase Margin		70		deg	OPOWER=0, 50 pF loading
			85		deg	OPOWER=1, 50 pF loading
GBW	Gain Bandwidth Product		40		kHz	OPOWER=0, 50 pF loading
			625		kHz	OPOWER=1, 50 pF loading
I _{OUT} OA	DC Load Current	-50		50	μA	OPOWER=0
		-250		250	μA	OPOWER=1
I _{OUT} CS	DC Load Current as Current Source	-1.2		1.2	mA	Op Amp B with MODE=1

Note: *Data in the Typical column is from characterization at 3.0V and 25°C. These values are provided for design guidance only and are not tested in production.

Table 342. Operational Amplifier Electrical Characteristics (Continued)

Symbol	Parameter	$T_A = -40^\circ\text{C to } +85^\circ\text{C}$			Units	Conditions
		$V_{DD} = 1.8 \text{ to } 3.6\text{V}$				
		Min	Typ*	Max		
GAIN_TOL	Op Amp A Internal Gain Network DC Gain Tolerance		0.6		%	INNSEL=01, GAIN select $\leq 10x$
			1.0		%	INNSEL=01, GAIN select $\geq 12x$
R_GAIN	Op Amp A Internal Gain Network Resistance		200k		Ω	INNSEL=01,
R_CS	Op Amp B Current Drive Resistor		31.25k		Ω	ISRCLVL=01
			3.125k		Ω	ISRCLVL=10
			321.5		Ω	ISRCLVL=11
R_CSTA	Op Amp B Current Drive Resistor Temperature Drift		–		ppm/ $^\circ\text{C}$	
R_OUT	Output Resistance		375	750	Ω	$V_{SS} \leq V_{AMP_OUT} \leq V_{DD}$, OPOWER=0
			225	550	Ω	$V_{SS} \leq V_{AMP_OUT} \leq V_{DD}$, OPOWER=1
			3	6	Ω	$V_{SS}+0.3\text{V} \leq V_{AMP_OUT} \leq V_{DD}-0.3\text{V}$, OPOWER=0
			1	3	Ω	$V_{SS}+0.3\text{V} \leq V_{AMP_OUT} \leq V_{DD}-0.3\text{V}$, OPOWER=1
SR	Slew Rate		15	30	mV/ μs	OPOWER=0
			260	525	mV/ μs	OPOWER=1
T_WAKE	Time for Wake up		2	5	μs	

Note: *Data in the Typical column is from characterization at 3.0V and 25°C. These values are provided for design guidance only and are not tested in production.

33.4.13. Low Voltage Detect

Table 343 presents electrical and timing data for the F6482 Series' Low Voltage Detect function.

Table 343. Low Voltage Detect Electrical Characteristics

Symbol	Parameter	$T_A = -40^\circ\text{C to } +85^\circ\text{C}$			Units	Conditions
		$V_{DD} = 1.8 \text{ to } 3.6\text{V}$				
		Min	Typ ¹	Max		
I _{DDLVDV}	LVD Active Current when VBO enabled		1.0		μA	Normal or Halt modes
			0.035		μA	Stop Mode
I _{DDLVD}	LVD Active Current when VBO disabled		2.0		μA	Normal or Halt modes
			0.07		μA	Stop Mode
V _{TH}	Detected Source Voltage	-5%	V _{TP} ²	+5%	V	
T _{DELAY}	Delay from source voltage falling lower than V _{TP} to LVD output logic High	50	1000		ns	

Notes:

1. Data in the Typical column is from characterization at 3.0V and 25°C. These values are provided for design guidance only and are not tested in production.
2. V_{TP} is a user-set threshold voltage to be detected. See [Table 294](#) on page 551 in the [Flash Option Bits](#) chapter on page 542.

33.4.14. Liquid Crystal Display

Table 344 presents electrical and timing data for the F6482 Series' Liquid Crystal Display (LCD) function.

Table 344. LCD Electrical Characteristics

Symbol	Parameter	$T_A = -40^\circ\text{C to } +85^\circ\text{C}$			Units	Conditions
		$V_{DD} = 1.8\text{V to } 3.6\text{V}$				
		Min	Typ ¹	Max		
V_{VLCD}	VLCD pin Voltage	1.8		3.6	V	
I_{DDLCD}	LCD Active Current with Internal Charge Pump Off (CPEN=0)		0.67 ²		μA	BIASGSEL=0, HBDUR=000
			1.19 ²		μA	BIASGSEL=0, HBDUR=001
			0.67 ²		μA	BIASGSEL=1, HBDUR=000
			2.75 ²		μA	BIASGSEL=1, HBDUR=001
I_{DDCP}	LCD Charge Pump Active Current (CPEN=1)		1.9 ³		μA	Doubler (CPTSEL=1, BIASGSEL=0)
			2.7 ³		μA	Tripler (CPTSEL=0, BIASGSEL=0)
			–		μA	Doubler (CPTSEL=1, BIASGSEL=1)
			–		μA	Tripler (CPTSEL=0, BIASGSEL=1)

Notes:

1. Data in the Typical column is from characterization at 3.0V and 25°C. These values are provided for design guidance only and are not tested in production.
2. Based on PCLK= 32.768kHz (CKSEL=0), 32 Hz frame rate (PRESCALE=011, FDIV=0111), and LCD mode of 1/4 duty, 1/3 bias, type A waveform (LCDMODE=1011). Either VLCD=3V (VLCDDIR=0) or $V_{DD}=3\text{V}$ (VLCDDIR=0, CPEN=0). No LCD panel load.
3. VLCD=3.06V (CONTRAST=100), $V_{DD}=3.0\text{V}$.

Table 344. LCD Electrical Characteristics (Continued)

		T _A = -40°C to +85°C				
		V _{DD} = 1.8V to 3.6V				
Symbol	Parameter	Min	Typ ¹	Max	Units	Conditions
V _{CPD}	LCD Charge Pump Output Voltage when doubler is selected (CPEN=1, CPTSEL=1)		2.5		V	V _{DD} ≥ 1.8V, CONTRAST=000
			2.64		V	V _{DD} ≥ 1.8V, CONTRAST=001
			2.78		V	V _{DD} ≥ 2.0V, CONTRAST=010
			2.92		V	V _{DD} ≥ 2.0V, CONTRAST=011
			3.06		V	V _{DD} ≥ 2.2V, CONTRAST=100
			3.20		V	V _{DD} ≥ 2.4V, CONTRAST=101
			3.35		V	V _{DD} ≥ 2.4V, CONTRAST=110
			3.5		V	V _{DD} ≥ 2.6V, CONTRAST=111

Notes:

1. Data in the Typical column is from characterization at 3.0V and 25°C. These values are provided for design guidance only and are not tested in production.
2. Based on PCLK= 32.768kHz (CKSEL=0), 32 Hz frame rate (PRESCALE=011, FDIV=0111), and LCD mode of 1/4 duty, 1/3 bias, type A waveform (LCDMODE=1011). Either VLCD=3V (VLCDDIR=0) or V_{DD}=3V (VLCDDIR=0, CPEN=0). No LCD panel load.
3. VLCD=3.06V (CONTRAST=100), V_{DD}=3.0V.

Table 344. LCD Electrical Characteristics (Continued)

		$T_A = -40^\circ\text{C to } +85^\circ\text{C}$				
		$V_{DD} = 1.8\text{V to } 3.6\text{V}$				
Symbol	Parameter	Min	Typ ¹	Max	Units	Conditions
V_{CPT}	LCD Charge Pump Output Voltage when tripler is selected (CPEN=1, CPTSEL=0)		2.5		V	$V_{DD} \geq 1.8\text{V}$, CONTRAST=000
			2.64		V	$V_{DD} \geq 1.8\text{V}$, CONTRAST=001
			2.78		V	$V_{DD} \geq 1.8\text{V}$, CONTRAST=010
			2.92		V	$V_{DD} \geq 1.8\text{V}$, CONTRAST=011
			3.06		V	$V_{DD} \geq 1.8\text{V}$, CONTRAST=100
			3.20		V	$V_{DD} \geq 1.8\text{V}$, CONTRAST=101
			3.35		V	$V_{DD} \geq 1.8\text{V}$, CONTRAST=110
			3.5		V	$V_{DD} \geq 2.0\text{V}$, CONTRAST=111
R_{BIAS}	Resistance of Bias Network (1/3 LCD waveform biasing, 1/2 LCD waveform biasing)		4.5, 4.5		M Ω	BIASGSEL=X, not during transition drive
			340, 240		k Ω	BIASGSEL=0, during medium transition drive
			100, 60		k Ω	BIASGSEL=1, during high transition drive
C_{VLCD}	Capacitance on VLCD pin		1		μF	
C_{PANEL}	VLCD Panel Capacitance			8000	pF	40 Hz frame frequency
TC_{VLCD}	Time to Charge VLCD with Internal Charge Pump	0.1		3	$\mu\text{F} \cdot \text{s}$	BIASGSEL = 0

Notes:

1. Data in the Typical column is from characterization at 3.0V and 25°C. These values are provided for design guidance only and are not tested in production.
2. Based on PCLK= 32.768kHz (CKSEL=0), 32 Hz frame rate (PRESCALE=011, FDIV=0111), and LCD mode of 1/4 duty, 1/3 bias, type A waveform (LCDDIR=1011). Either VLCD=3V (VLCDDIR=0) or $V_{DD}=3\text{V}$ (VLCDDIR=0, CPEN=0). No LCD panel load.
3. VLCD=3.06V (CONTRAST=100), $V_{DD}=3.0\text{V}$.

33.4.15. Universal Serial Bus

Table 345 presents electrical and timing data for the F6482 Series' Universal Serial Bus (USB) function.

Table 345. USB Electrical Characteristics

		$T_A = -40^\circ\text{C to } +85^\circ\text{C}$				
		$V_{DD} = 3.0\text{V to } 3.6\text{V}$				
Symbol	Parameter	Min	Typ*	Max	Units	Conditions
V_{IL}	Low Level Input Voltage			0.8	V	
V_{IH}	High Level Input Voltage	2.0			V	
V_{CM}	Common Mode Range	0.8		2.5	V	
V_{DI}	Differential Input Sensitivity	0.2			V	
V_{OL}	Low Level Output Voltage	0		0.3	V	1.5k Ω to 3.6V and 27 Ω external series resistor.
V_{OH}	High Level Output Voltage	2.8		V_{DD}	V	15k Ω to VSS and 27 Ω external series resistor.
R_{DR}	D+, D- Driver Output Resistance	28		44	Ω	Including 27 Ω external series resistor.
R_{PUUSB}	Internal Pull-up Resistor	900		1575	Ω	Idle bus state.
		1425		3090	Ω	Receiving.

Note: *Data in the Typical column is from characterization at 3.0V and 25°C. These values are provided for design guidance only, and are not tested in production.

33.4.16. Internal Precision Oscillator

Table 346 presents electrical and timing data for the F6482 Series' Internal Precision Oscillator (IPO) function.

Table 346. IPO Electrical Characteristics

		$V_{DD} = 1.8\text{ to } 3.6\text{V}$				
		$T_A = -40^\circ\text{C to } +85^\circ\text{C}$				
Symbol	Parameter	Min	Typ*	Max	Units	Conditions
I_{DD}^{IPO}	IPO Active Supply Current		1.3		μA	

Note: *Data in the Typical column is from characterization at 3.0V and 25°C. These values are provided for design guidance only and are not tested in production.

Table 346. IPO Electrical Characteristics (Continued)

		V _{DD} =1.8 to 3.6V T _A =-40°C to +85°C				
Symbol	Parameter	Min	Typ*	Max	Units	Conditions
F _{IPO}	Output Frequency	-2%	32.768	+2%	kHz	
	Duty Cycle of Output	45		55	%	
T _{WAKE}	Time for Wake up		25		μs	

Note: *Data in the Typical column is from characterization at 3.0V and 25°C. These values are provided for design guidance only and are not tested in production.

33.4.17. High Frequency Crystal Oscillator

Table 347 presents electrical and timing data for the F6482 Series' High Frequency Crystal Oscillator function.

Table 347. High Frequency Crystal Oscillator (HFXO) Characteristics

		T _A =-40°C to +85°C				
		V _{DD} =1.8 to 3.6V				
Symbol	Parameter	Min	Typ ¹	Max	Units	Conditions
I _{DD} HFXO	HFXO Active Supply Current		100		μA	HFXOBAND=00 ²
			150		μA	HFXOBAND=01 ²
			200		μA	HFXOBAND=10 ²
F _{XTAL}	HFXO Frequency	1		8	MHz	HFXOBAND=00
		> 8		16	MHz	HFXOBAND=01
		>16		24	MHz	HFXOBAND=10
gm	Oscillator Transconductance	0.4			mA/V	HFXOBAND=00 ²
		1.0			mA/V	HFXOBAND=01 ²
		2.5			mA/V	HFXOBAND=10 ²
T _{WAKE}	Time for Wake up		2	4	ms	HFXOBAND=00 ²
			1.2	2.4	ms	HFXOBAND=01 ²
			1	2	ms	HFXOBAND=10 ²
	SCKOUT Duty Cycle	40	50	60	%	

Notes:

1. Data in the Typical column is from characterization at 3.0V and 25°C. These values are provided for design guidance only and are not tested in production.
2. C_{LOAD}=12.5 pF.

33.4.18. Low Frequency Crystal Oscillator

Table 348 presents electrical and timing data for the F6482 Series' Low Frequency Crystal Oscillator function.

Table 348. Low Frequency Oscillator (LFXO) Characteristics

Symbol	Parameter	$T_A = -40^{\circ}\text{C to } +85^{\circ}\text{C}$			Units	Conditions
		Min	Typ*	Max		
I_{DDLFXO}	LFXO Active Current		0.13		μA	$C_{LOAD} = 7\text{ pF}$
			0.3		μA	$C_{LOAD} = 12.5\text{ pF}$
F_{XTAL2}	LFXO Frequency		32.768		kHz	
gm	Oscillator Transconductance	5			$\mu\text{A/V}$	
T_{WAKE}	Time for Wake up		400	1000	ms	
	SCKOUT Duty Cycle	40	50	60	%	

Note: *Data in the Typical column is from characterization at 3.0V and 25°C. These values are provided for design guidance only and are not tested in production.

33.4.19. Phase-Locked Loop Oscillator

Table 349 presents electrical and timing data for the F6482 Series' Phase-Locked Loop Oscillator (PLL) function.

Table 349. PLL Electrical Characteristics

Symbol	Parameter	$V_{DD} = 1.8\text{ to } 3.6\text{V}$			Units	Conditions
		Min	Typ*	Max		
I_{DDPLL}	IPO Active Supply Current		2.5		mA	$F_{PLLVCO} = 96\text{ MHz}$
$F_{PLLCLKIN}$	PLL Input Clock Frequency	0.3125		24	MHz	
F_{PLLVCO}	PLL VCO Frequency	80		384	MHz	
F_{PLLCLK}	PLL Output Clock Frequency	10		48	MHz	
	Duty Cycle of Output	45		55	%	
T_{WAKE}	Time for Wake up		512		Clocks	$PLL_{CLKIN} \times (RDIV+1)$

Note: *Data in the Typical column is from characterization at 3.0V and 25°C. These values are provided for design guidance only and are not tested in production.

33.4.20. Digitally Controlled Oscillator and Frequency-Locked Loop

Table 350 presents electrical and timing data for the F6482 Series' Digitally Controlled Oscillator (DCO) and Frequency-Locked Loop functions.

Table 350. DCO and FLL Electrical Characteristics

Symbol	Parameter	$V_{DD}=1.8$ to $3.6V$ $T_A=-40^{\circ}C$ to $+85^{\circ}C$			Units	Conditions
		Min	Typ*	Max		
I_{DDDCO}	DCO Active Supply Current		25		μA	$F_{DCO}=1MHz$
			90		μA	$F_{DCO}=10MHz$
			125		μA	$F_{DCO}=20MHz$
			150		μA	$F_{DCO}=24MHz$
I_{DDFLL}	FLL Active Supply Current		20		μA	
F_{DCO}	DCO Frequency	1		24	MHz	
$F_{FLLCLKIN}$	FLL Input Clock Frequency		32.768		kHz	
	Duty Cycle of DCO Output	45		55	%	
	DCO Resolution		150		ps	
	DCO control word resolution, {DCOCTLCH, DCODTLCL}		600		ps	
$T_{FLADONE}$	FLL Fast Lock Algorithm Time (FLADONE=1)		2.5		ms	PCLK=32.768kHz; fast locking selected

Note: *Data in the Typical column is from characterization at 3.0V and 25°C. These values are provided for design guidance only and are not tested in production.

33.4.21. General-Purpose I/O Port Input Data Sample Timing

Figure 107 and Table 351 present the timing of the GPIO port input sampling. The input value on a GPIO port pin is sampled on the rising edge of the system clock. The port value is available to the eZ8 CPU on the second rising clock edge following the change of the port value.

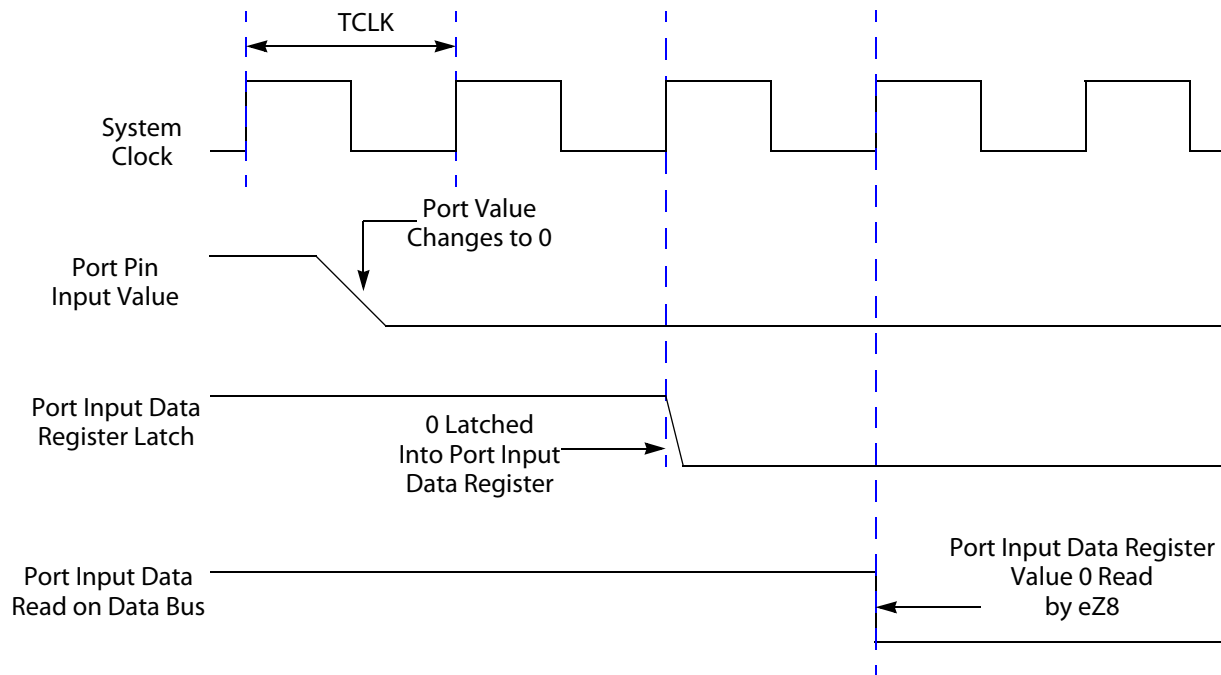

Figure 107. Port Input Sample Timing

Table 351. GPIO Port Input Timing

Parameter	Abbreviation	Delay (ns)	
		Min	Max
T _{S_PORT}	Port Input Transition to X _{IN} Rise Setup Time (Not pictured)	5	–
T _{H_PORT}	X _{IN} Rise to Port Input Transition Hold Time (Not pictured)	0	–
T _{SMRPW}	GPIO Port Pin Pulse Width to ensure Stop-Mode Recovery (for GPIO port pins enabled as SMR sources)	125	

33.4.22. General-Purpose I/O Port Output Timing

Figure 108 and Table 352 provide timing information for the GPIO port pins.

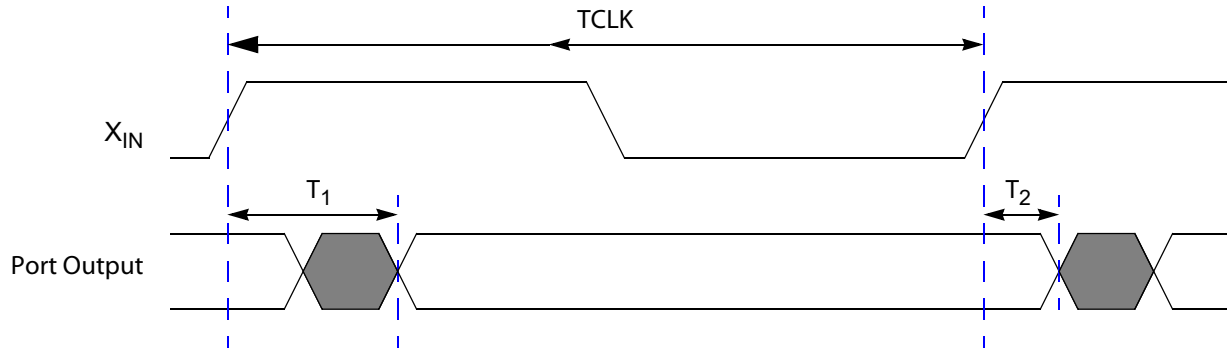

Figure 108. GPIO Port Output Timing

Table 352. GPIO Port Output Timing

Parameter	Abbreviation	Delay (ns)	
		Min	Max
GPIO Port Pins			
T ₁	X _{IN} Rise to Port Output Valid Delay	–	15
T ₂	X _{IN} Rise to Port Output Hold Time	2	–

33.4.23. On-Chip Debugger Timing

Figure 109 and Table 353 provide timing information for the DBG pin. The DBG pin timing specifications assume a 4ns maximum rise and fall time.

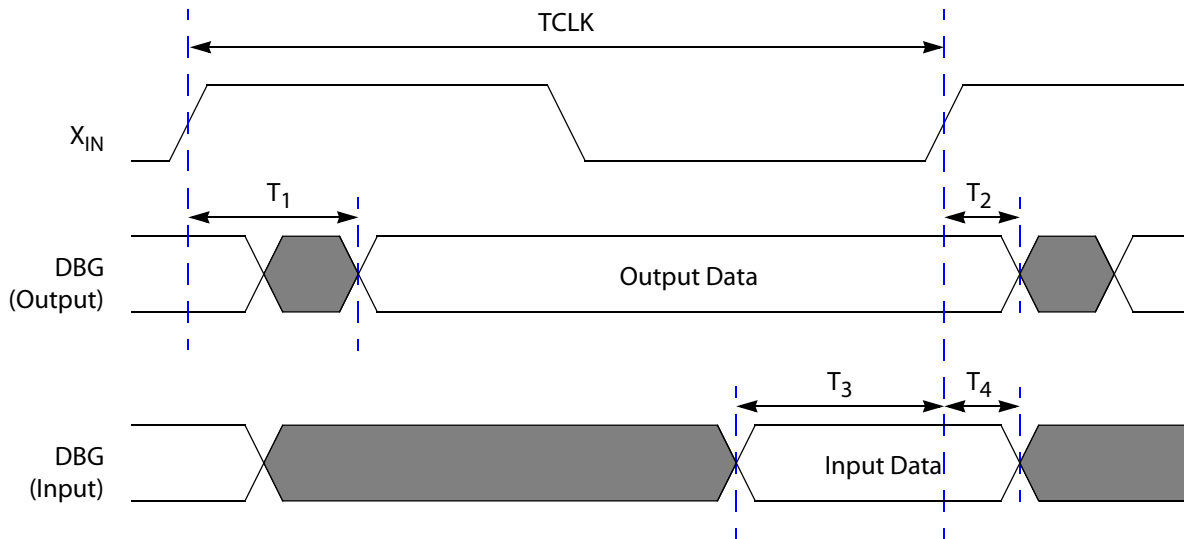

Figure 109. On-Chip Debugger Timing

Table 353. On-Chip Debugger Timing

Parameter	Abbreviation	Delay (ns)	
		Min	Max
DBG			
T ₁	X _{IN} Rise to DBG Valid Delay	–	15
T ₂	X _{IN} Rise to DBG Output Hold Time	2	–
T ₃	DBG to X _{IN} Rise Input Setup Time	5	–
T _{DBGPW}	DBG Pulse Width to be Recognized	125	

33.4.24. UART Timing

Figure 110 and Table 354 provide timing information for the UART pins for situations in which CTS is used for flow control. The CTS to DE assertion delay (T₁) assumes that the Transmit Data Register has been loaded with data prior to CTS assertion.

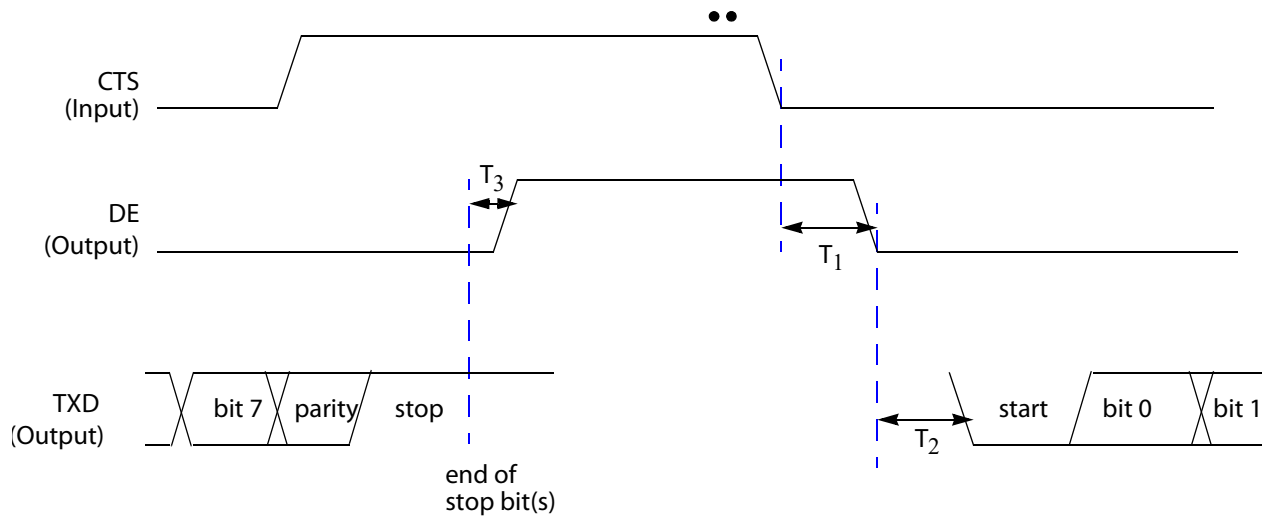

Figure 110. UART Timing With CTS

Table 354. UART Timing with CTS

Parameter	Abbreviation	Delay (ns)	
		Min	Max
T ₁	CTS Fall to DE output delay	2 * X _{IN} period	2 * X _{IN} period + 1 bit time
T ₂	DE assertion to TXD falling edge (start bit) delay	± 5	
T ₃	End of Stop Bit(s) to DE deassertion delay	± 5	

Figure 111 and Table 355 provide timing information for the UART pins for situations in which CTS is not used for flow control. DE asserts after the Transmit Data Register has been written. DE remains asserted for multiple characters as long as the Transmit Data Register is written with the next character before the current character has completed.

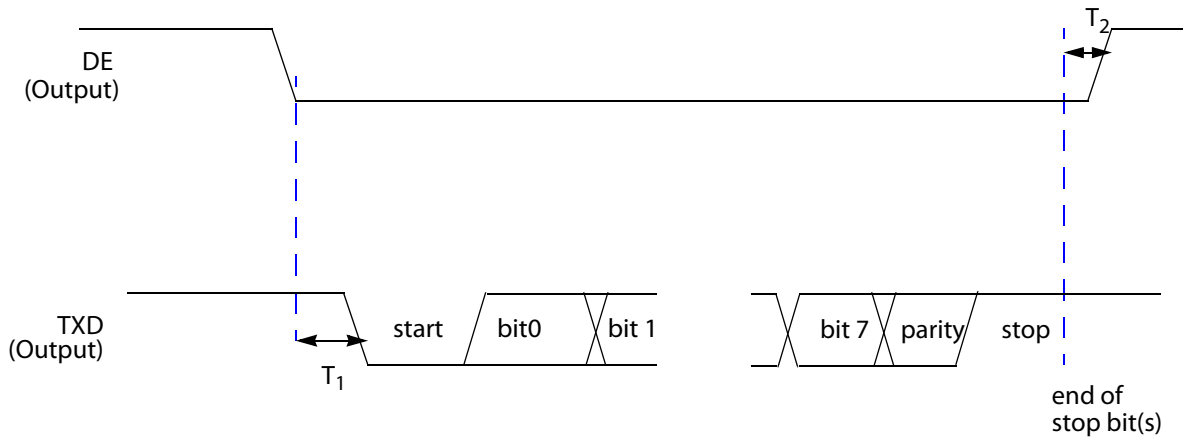

Figure 111. UART Timing Without CTS

Table 355. UART Timing Without CTS

Parameter	Abbreviation	Delay (ns)	
		Min	Max
T ₁	DE assertion to TXD falling edge (start bit) delay	1 * SYSCLK period	1 bit time
T ₂	End of Stop Bit(s) to DE deassertion delay (Tx Data Register is empty)	± 5	

Chapter 34. Packaging

Zilog's F6482 Series of MCUs includes the Z8Fxx82 and Z8Fxx81 devices.

The Z8F6482, Z8F6082, Z8F3282 and Z8F1682 devices are available in the following packages:

- 64-pin Low-Profile Quad Flat Package, 10mm x10mm (LQFP)
- 80-pin Low-Profile Quad Flat Package (LQFP)

The Z8F6481, Z8F6081, Z8F3281 and Z8F1681 are available in the following packages:

- 32-pin Quad Flat No Lead (QFN)
- 44-pin Quad Flat No Lead (QFN)
- 44-pin Low-Profile Quad Flat Package (LQFP)
- 64-pin Low-Profile Quad Flat Package, 10mm x10mm (LQFP)

Current diagrams for each of these packages are published in Zilog's [Packaging Product Specification \(PS0072\)](#), which is available free for download from the Zilog website.

Chapter 35. Ordering Information

35.1. Part Number Listing

Order your F6482 Series devices from Zilog using the part numbers listed in Table 356. For more information about ordering, please consult your local Zilog sales office. The [Zilog website](#) lists all regional offices and provides additional Z8 Encore! XP product information.

Table 356. F6482 Series Ordering Information

Part Number	Flash	Register RAM	LCD	128B NVDS	I ² C Master/Slave Controller	ESPI	USB	I/O Lines	Interrupt Vectors	16-Bit Timers w/ PWM	12-Bit A/D Channels	UART with LIN/DALI/DMX	Comparator	Op Amp	Temperature Sensor	Multichannel Timer	Description
Z8 Encore! XP F6482 Series with 64KB Flash, 12-Bit Analog-to-Digital Converter																	
Extended Temperature: -40 °C to 85 °C																	
Z8F6482AT024XK	64KB	3.75KB	1	0	1	2	1	67	41	3	12	2	2	2	1	1	LQFP 80-pin package
Z8F6482AR024XK	64KB	3.75KB	1	0	1	2	0	51	30	3	8	1	1	1	1	0	LQFP 64-pin package
Z8F6481AR024XK	64KB	3.75KB	0	0	1	2	1	52	40	3	12	2	2	2	1	1	LQFP 64-pin package
Z8F6481QN024XK	64KB	3.75KB	0	0	1	1	1	36	39	3	10	2	2	2	1	1	QFN 44-pin package
Z8F6481AN024XK	64KB	3.75KB	0	0	1	1	1	36	39	3	10	2	2	2	1	1	LQFP 44-pin package
Z8F6481QK024XK	64KB	3.75KB	0	0	1	1	1	26	31	3	9	1	1	1	1	0	QFN 32-pin package

Table 356. F6482 Series Ordering Information

Part Number	Flash	Register RAM	LCD	128B NVDS	I ² C Master/Slave Controller	ESPI	USB	I/O Lines	Interrupt Vectors	16-Bit Timers w/ PWM	12-Bit A/D Channels	UART with LIN/DALI/DMX	Comparator	Op Amp	Temperature Sensor	Multichannel Timer	Description
Z8 Encore! XP F6082 Series with 60KB Flash, 12-Bit Analog-to-Digital Converter																	
Extended Temperature: –40 °C to 85 °C																	
Z8F6082AT024XK	60KB	3.75KB	1	1	1	2	1	67	41	3	12	2	2	2	1	1	LQFP 80-pin package
Z8F6082AR024XK	60KB	3.75KB	1	1	1	2	0	51	30	3	8	1	1	1	1	0	LQFP 64-pin package
Z8F6081AR024XK	60KB	3.75KB	0	1	1	2	1	52	40	3	12	2	2	2	1	1	LQFP 64-pin package
Z8F6081QN024XK	60KB	3.75KB	0	1	1	1	1	36	39	3	10	2	2	2	1	1	QFN 44-pin package
Z8F6081AN024XK	60KB	3.75KB	0	1	1	1	1	36	39	3	10	2	2	2	1	1	LQFP 44-pin package
Z8F6081QK024XK	60KB	3.75KB	0	1	1	1	1	26	31	3	9	1	1	1	1	0	QFN 32-pin package
Z8 Encore! XP F3282 Series with 32KB Flash, 12-Bit Analog-to-Digital Converter																	
Extended Temperature: –40 °C to 85 °C																	
Z8F3282AT024XK	32KB	3.75KB	1	1	1	2	1	67	41	3	12	2	2	2	1	1	LQFP 80-pin package
Z8F3282AR024XK	32KB	3.75KB	1	1	1	2	0	51	30	3	8	1	1	1	1	0	LQFP 64-pin package
Z8F3281AR024XK	32KB	3.75KB	0	1	1	2	1	52	40	3	12	2	2	2	1	1	LQFP 64-pin package
Z8F3281QN024XK	32KB	3.75KB	0	1	1	1	1	36	39	3	10	2	2	2	1	1	QFN 44-pin package
Z8F3281AN024XK	32KB	3.75KB	0	1	1	1	1	36	39	3	10	2	2	2	1	1	LQFP 44-pin package
Z8F3281QK024XK	32KB	3.75KB	0	1	1	1	1	26	31	3	9	1	1	1	1	0	QFN 32-pin package

Table 356. F6482 Series Ordering Information

Part Number	Flash	Register RAM	LCD	128B NVDS	I ² C Master/Slave Controller	ESPI	USB	I/O Lines	Interrupt Vectors	16-Bit Timers w/ PWM	12-Bit A/D Channels	UART with LIN/DALI/DMX	Comparator	Op Amp	Temperature Sensor	Multichannel Timer	Description
Z8 Encore! XP F1682 Series with 16KB Flash, 12-Bit Analog-to-Digital Converter																	
Extended Temperature: –40 °C to 85 °C																	
Z8F1682AT024XK	16KB	2KB	1	1	1	2	1	67	41	3	12	2	2	2	1	1	LQFP 80-pin package
Z8F1682AR024XK	16KB	2KB	1	1	1	2	0	51	30	3	8	1	1	1	1	0	LQFP 64-pin package
Z8F1681AR024XK	16KB	2KB	0	1	1	2	1	52	40	3	12	2	2	2	1	1	LQFP 64-pin package
Z8F1681QN024XK	16KB	2KB	0	1	1	1	1	36	39	3	10	2	2	2	1	1	QFN 44-pin package
Z8F1681AN024XK	16KB	2KB	0	1	1	1	1	36	39	3	10	2	2	2	1	1	LQFP 44-pin package
Z8F1681QK024XK	16KB	2KB	0	1	1	1	1	26	31	3	9	1	1	1	1	0	QFN 32-pin package
Z8 Encore! XP F6482 Series Development Kit																	
Z8F64820100ZCOG	Z8 Encore! XP F6482 Series Development Kit																
ZUSBSC00100ZACG	USB Smart Cable Accessory Kit																
ZUSBOPTSC01ZACG	USB Opto-Isolated Smart Cable Accessory Kit																
ZENETSC0100ZACG	Ethernet Smart Cable Accessory Kit																



Table 357 shows the F6482 Series of microcontrollers that specifically support the ZMOTION Engine Library. A specific version of the device must be used for the Library to operate correctly. This version is identified by the 2247 suffix on the device part number.

Please refer to UM0275 for more information about the Z8F6482 ZMOTION Library.

Table 357. ZMOTION Library Series Ordering Information

Part Number	Package	Memory
Z8F1681QK024XK2247	32-Pin QFN	16KB Flash, 2KB RAM
Z8F1681QN024XK2247	44-Pin QFN	16KB Flash, 2KB RAM
Z8F1681AN024XK2247	44-Pin LQFP	16KB Flash, 2KB RAM
Z8F6481QN024XK2247	44-Pin QFN	64KB Flash, 3.75KB RAM
Z8F6481AN024XK2247	44-Pin LQFP	64KB Flash, 3.75KB RAM

35.2. Part Number Suffix Designations

Zilog part numbers consist of a number of components, as indicated in the following example.

Example. Part number Z8F6482AT024XK is an 8-bit, 24MHz Flash microcontroller with 64KB of Flash memory and containing an LCD peripheral in an 80-pin LQFP package, operating within a -40°C to +85°C temperature range and built using lead-free solder.

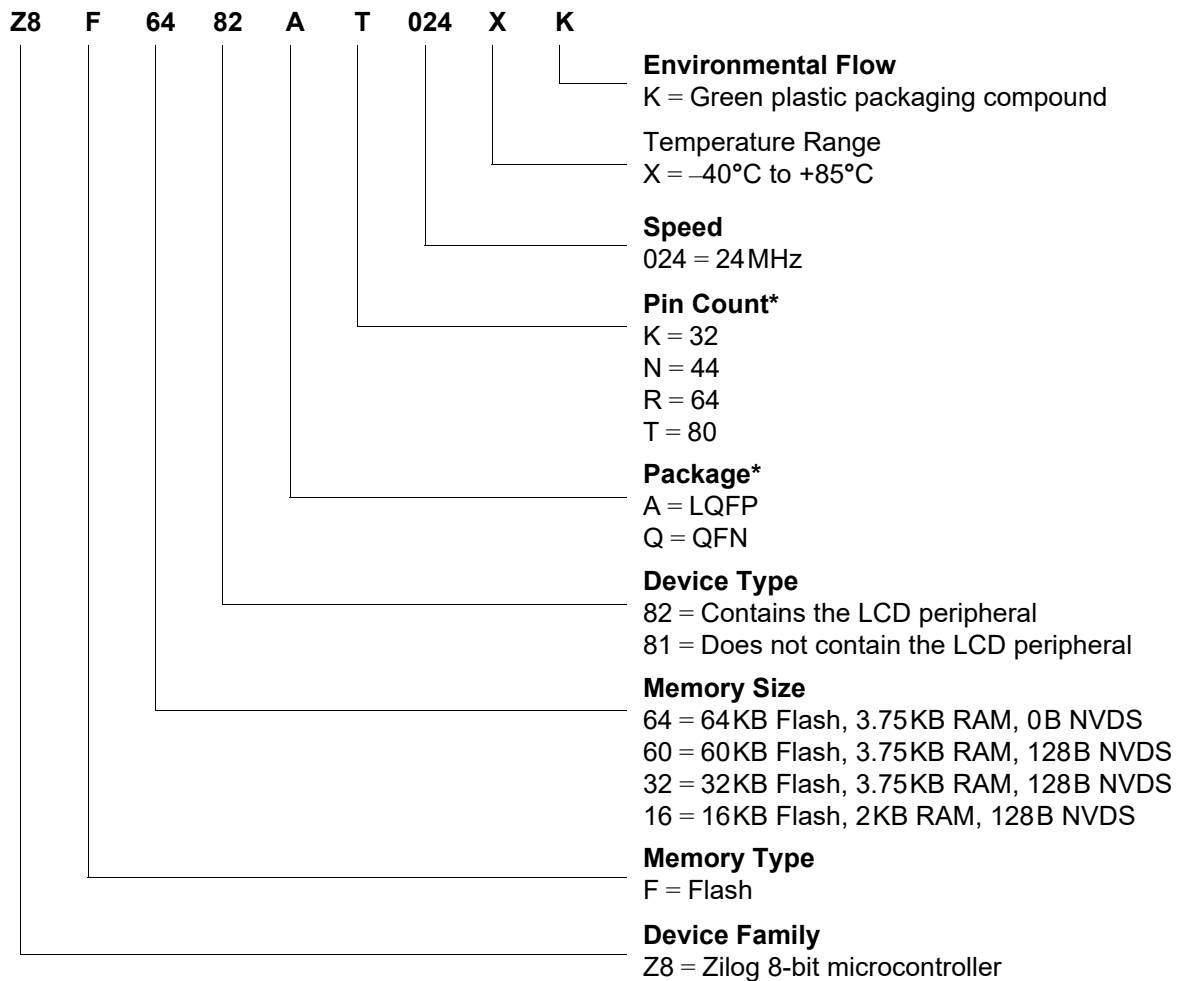

Note: * See Table 358 for the combination of package and pin count.

Table 358. Package and Pin Count Description

		Pin Count			
		32	44	64	80
Package	QFN	√	√		
	LQFP		√	√	√

35.3. Precharacterization Product

The product represented by this document is newly introduced, and Zilog has not completed the full characterization of the product. This document states all information that Zilog knows about this product at this time, but additional features or nonconformance with some aspects of the document might be found, either by Zilog or its customers, in the course of further application and characterization work. In addition, Zilog cautions that delivery might be uncertain at times, because of start-up yield issues.

Index

Symbols

@ 583
583
% 583

Numerics

10-bit ADC 5

A

absolute maximum ratings 601
AC characteristics 604
acronyms and expansions 9
active state 243
ADC 584
 12-bit resolution timing 447
 2-pass 14-bit resolution timing 448
 architecture 439
 block diagram 440
 calibration and compensation 451
 channel scanning 444
 continuous conversion 444
 control 0 register 452
 control 1 register 454
 control 2 register 454
 control register definitions 452
 conversion averaging 445
 conversion options 444
 data format 442
 data high register 460
 data low register 460
 electrical characteristics 608
 electrical characteristics and timing 608
 input modes 441
 input select high register 455
 input select low register 456
 interrupts and DMA 451
 offset calibration register 459

 operation 440
 power control 445
 references 446
 resolution 445
 sample time register 461
 single-shot 444
 starting and stopping conversions 445
 start-up, sampling, and settling 449
 timing 447
 window detection 450
 window lower threshold high register 464
 window lower threshold low register 465
 window upper threshold high register 462
 window upper threshold low register 463
ADC Channel Register 1 (ADCCTL) 520, 521, 522
ADC Data High Byte Register (ADCDH) 523, 524, 526
ADC Data Low Bit Register (ADC DL) 464, 465, 472, 527, 528
ADCX 584
ADD 584
add - extended addressing 584
add with carry 584
add with carry - extended addressing 584
additional symbols 583
Address Space 24
ADDX 584
Advanced Encryption Standard Accelerator – see AES 424
AES
 architecture 424
 CBC mode description 430, 432
 CBC mode encryption example 433
 cipher block chaining (CBC) mode 432
 cipher text 425
 control register 437
 data register 435
 decrypt key derivation 434
 ECB decryption example 429
 ECB encryption example 429

- electronic codebook (ECB) mode 427
 - hardware assist 424
 - initialization vector 429
 - initialization vector register 436
 - key register 436
 - OFB mode encryption example 431
 - operation 425
 - output feedback (OFB) mode 430
 - plain text 425
 - register definitions 434
 - Rijndael cipher encoding and decoding algorithm 424
 - software assist 424
 - status register 438
 - AES accelerator block diagram 425
 - AES ECB mode description 428
 - AES operation and DMA 427
 - alarm condition 211, 212, 229
 - alarm status 211
 - alternating between banks, LCD 505
 - amplifier 51, 476
 - programmable gain 474, 477
 - settling time 447, 448
 - analog signals 20
 - Analog-to-Digital Converter – see ADC 439
 - AND 586
 - ANDX 586
 - architecture
 - ADC 439
 - AES 424
 - clock system 97
 - comparators and reference system 487
 - DAC 466
 - DMA controller 390
 - ESPI 281
 - event system 411
 - GPIO 56
 - I2C 306
 - interrupt controller 130
 - LCD controller 503
 - multi-channel timers 187
 - noise filter 255
 - OCD 560
 - op amps 474
 - timers 150
 - UART-LDD 231
 - USB 340
 - arithmetic instructions 584
 - autobaud state 242
- B**
- B 583
 - b 582
 - baud rate generator
 - ESPI 294
 - interrupts, UART 253
 - UART 254
 - BCD 211, 213, 214, 217, 218, 219, 220, 221, 222, 223, 224, 225, 229
 - counting 228
 - BCD_EN 213, 214, 215, 216, 218, 219, 220, 221, 222, 223, 224, 225, 228
 - BCLR 585
 - binary number suffix 583
 - binary operation 211, 215, 216, 217, 219, 220, 221, 222, 223, 224, 225
 - binary-coded decimal operation – see BCD 211
 - BIT 585
 - bit 582
 - clear 585
 - manipulation instructions 585
 - set 585
 - set or clear 585
 - swap 585
 - test and jump 587
 - test and jump if non-zero 587
 - test and jump if zero 587
 - bit jump and test if non-zero 587
 - bit swap 587
 - blanking the LCD display 505
 - block diagram
 - ADC 440
 - AES accelerator 425
 - comparators 487
 - DAC 467
 - DMA 391
 - ESPI 282

- event system 412
- F6482 series architecture 4
- I2C 307
- input path 172
- interrupt controller 130
- LCD controller 504
- LCD voltage and bias generation 509
- noise filter system 172, 255
- OCD 560
- Op Amp A 475
- Op Amp B 476
- PLL 112
- real-time clock 210
- reference system 488
- timer 150
- UART-LDD 231
- USB 340
- block transfer instructions 585
- BRK 587
- BSET 585
- BSWAP 585, 587
- BTJ 587
- BTJNZ 587
- BTJZ 587
- byte read, NVDS 557
- byte write, NVDS 556

- C**
- calendar mode operation
 - mode = 0 226
 - mode = 1 227
- calibration
 - and compensation, ADC 451
 - temperature sensor 502
- CALL procedure 587
- capture mode 181, 182
- capture/compare mode 181
- CBC mode description, AES 430, 432
- CBC mode encryption example, AES 433
- cc 582
- CCF 585
- channel scanning
 - ADC 444
- cipher block chaining (CBC) mode, AES 432
- clear 586
- clear to send, UART 236
- clock control 5 120
- clock phase, SPI 285
- clock selection 98
- Clock System 96
- clock system
 - architecture 97
 - clock control 0 register 114
 - clock control 1 register 116
 - clock control 2 register 117
 - clock control 3 register 118
 - clock control 4 register 119
 - clock control 5 register 120
 - clock control 6 register 121
 - clock control 7 register 122
 - clock control 8 register 122
 - clock control 9 register 123
 - clock control A register 123
 - clock control B register 125
 - clock control C register 126
 - digitally controlled oscillator 108
 - failure detection and recovery 103
 - frequency locked loop 109
 - high-frequency crystal oscillator 104
 - IPO 107
 - low-frequency crystal oscillator 106
 - phase locked loop 112
 - register definitions 114
 - selection 98
 - watchdog timer oscillator 108
- CLR 586
- code interface, NVDS 556
- COM 586
- comparator
 - 0 control 0 register 495
 - 0 control 1 register 496
 - 1 control 0 register 497
 - 1 control 1 register 498
 - control register 494
 - electrical characteristics and timing 614
 - electrical characteristics, converter 614
- comparators

- operation 489
- Comparators and Reference System 486
- comparators and reference system
 - architecture 487
 - control register definitions 493
- comparators block diagram 487
- compare - extended addressing 584
- compare with carry 584
- compare with carry - extended addressing 584
- complement 586
- complement carry flag 585
- condition code 582
- continuous conversion, ADC 444
- control register
 - AES 437
- control register definitions, ESPI 295
- control register definitions, UART 258
- control register, I2C 331
- control transfers, USB 345
- conversion options, ADC 444
- counter mode operation 214, 215, 216, 217, 221, 222, 223, 224
- CP 584
- CPC 584
- CPCX 584
- CPU and peripheral overview 5
- CPU control instructions 585
- CPX 584
- current measurement
 - operation 504
- current sinking 474, 484
- current sourcing 474, 484
- Customer Feedback Form 659

D

- DA 582, 584
- DAC 466
 - architecture 466
 - block diagram 467
 - control register 470
 - control register definitions
 - register definitions
 - DAC control 470

- data high register 472
- data low register 472
- electrical characteristics 612
- electrical characteristics and timing 612
- interrupts and DMA 470
- operation 467
- power control 469
- starting a conversion 468
- voltage references 469
- DALI
 - clock requirements, UART 244
 - mode initialization, UART 245
 - mode operation, UART 245
 - protocol mode, UART 243
- DALI clock requirements
 - UART 244
- DALI mode initialization
 - UART 245
- DALI mode operation
 - UART 245
- DALI protocol mode
 - UART 243
- DALI receive during Stop Mode, UART 247
- DALI receive operation, UART 246
- DALI transmit operation, UART 245
- data
 - program 26
- data format, ADC 442
- data memory 26
- data register, ESPI 295
- data register, I2C 329
- data-handling procedure, UART-LDD 252
- DC characteristics 602
- DCO 108
 - electrical characteristics 626
- DEC 584
- decimal adjust 584
- decrement 584
- decrement and jump non-zero 587
- decrement word 584
- decrypt key derivation, AES 434
- DECW 584
- destination operand 583
- destination selection

- event system 414
- device, port availability 55
- DI 585
- digitally controlled oscillator 108
 - DCO operation 108
 - operating modes 108
- Digital-to-Analog Converter 466
- direct address 582
- Direct Memory Access Controller 390
- disable interrupts 585
- DJNZ 587
- DMA
 - 0–3 subaddress/status registers 400
 - 0–3 subdata registers 401
 - ADC interrupts 451
 - AES operation and 427
 - and DAC interrupts 470
 - and ESPI 294
 - block diagram 391
 - control register definitions 213, 399
 - control, I2C transactions 326
 - controller architecture 390
 - controller operation 391
 - destination address subregisters 404
 - global control register 402
 - multi-channel timer 192
 - source address subregisters 403
 - support, UART-LDD 254
 - transfer in list option 396
- DMX
 - clock requirements, UART 248
 - master mode operation, UART 249
 - mode initialization, UART 249
 - mode operation, UART 249
 - protocol mode, UART 247
 - slave during Stop Mode, UART 250
 - slave operation, UART 249
- dst 583

- E**
- EI 585
- electrical characteristics 601
 - absolute maximum ratings 601
 - AC 604
 - ADC 608
 - analog-to-digital converter 608
 - comparator 614
 - comparator converter 614
 - DAC 612
 - DC 602
 - digitally controlled oscillator and frequency-locked loop 626
 - digital-to-analog converter 612
 - Flash memory 607
 - GPIO input data sample timing 627
 - high frequency crystal oscillator 624
 - internal precision oscillator 623
 - liquid crystal display 620
 - low voltage detect 619
 - low-frequency crystal oscillator 625
 - non-volatile data atorage 608
 - NVDS 608
 - on-chip peripheral AC and DC 605
 - op amps 617
 - phase-locked loop oscillator 625
 - power-on reset 605
 - reference system 615
 - temperature sensor 616
 - universal serial bus 623
 - watchdog timer 607
- electrical noise 440
- electronic codebook (ECB) mode, AES 427
- enable interrupt 585
- endpoint buffer memory, USB 341
- Enhanced Serial Peripheral Interface – see ESPI 281
- ER 582
- error-handling procedure, UART-LDD 252
- ESPI
 - and DMA 294
 - architecture 281
 - baud rate generator 294
 - baud rate high and low byte register 303
 - block diagram 282
 - clock phase 285
 - control register definitions 295
 - data register 295

- error detection 292
- interrupts 293
- master operation 290
- mode fault error 293
- mode register 299
- multi-master operation 291
- operation 284
- protocol configuration 289
- receive overrun error 293
- serial clock 283
- signals 283
- slave mode abort error 293
- slave operation 291
- slave select 283
- slave select modes of operation 287
- slave select, I2S mode 289
- slave select, SPI Mode
 - slave SPI mode select, ESPI 287
- status register 301
- throughput 285
- transfer format 285, 286
- transmit data command register 296
- transmit underrun error 292
- event system 411
 - architecture 411
 - block diagram 412
 - channel 0–7 source subregisters 420
 - destination 0–3F channel subregisters 423
 - destination selection 414
 - destination subaddress register 421
 - destination subdata register 422
 - register definitions 417
 - source selection 412
 - source subaddress register 418
 - source subdata register 419
 - timing considerations 415
 - usage examples 415
- example
 - AES decryption, ECB mode 429
 - AES encryption, CBC mode 433
 - AES encryption, ECB mode 429
 - AES encryption, OFB mode 431
 - event system
 - usage 415

- multi-channel timer application 193
- extended addressing register 582
- external driver enable, UART 236
- external pin
 - reset 43
- eZ8 CPU
 - assembly language programming 580
 - assembly language syntax 581
 - features 5
 - instruction classes 583
 - instruction notation 582
 - instruction set 580
 - instruction summary 588

F

- F6482 Series
 - available packages 12
 - block diagram 4
 - features 1
 - overview 1
 - part selection guide 2
 - pin characteristics 22
 - pin configurations 12
 - signal descriptions 18
- failure detection and recovery
 - clock system 103
- FBP register 540
- features, F6482 Series 1
- FiltSatB 172, 255, 256
- first op code map 599
- flags register 583
- Flash
 - controller 5
 - option bit address space 546
 - option bit configuration by reset 542
 - option bit control register definitions 544
 - option bit types 542
 - option bits, zilog device data 543
 - register definitions
 - Flash option bit control 544
 - trim bit address space 548
 - trim option bits 543
 - user option bits 542

- zilog option bits 543
- Flash information area 26, 531
- Flash memory 529
 - arrangement 530
 - block protection 534
 - byte programming 534
 - byte programming mode 535
 - code protection against accidental program and erasure 533
 - code protection against external access 533
 - code protection using the Flash controller 533
 - control register 537
 - control register definitions 537
 - controller behavior in debug mode 536
 - controller bypass 536
 - Flash block protect register 540
 - Flash programming configuration register 541
 - Flash status register 538
 - information area 531
 - mass erase 536
 - operation 531
 - page erase 535
 - page select register 539
 - programming 534
 - timing operation 533
 - word programming mode 535
- Flash option bits 542
 - address space 546
 - configuration by reset 542
 - operation 542
 - trim 543
 - trim bit address 0003h 550
 - trim bit address 0004h 550
 - trim bit address 0005h 552
 - trim bit address 0006h 552
 - trim bit address 0007h 553
 - trim bit address 000Ah 554
 - trim bit address 000Bh 555
 - trim bit address 000Ch 555
 - trim bit address register 0000h 548
 - trim bit address space 548
 - trim bit addresses 0001h and 0002h 549
 - trim bit addresses 0008h and 0009h 553
 - trim bit data register 546

- types 542
- user 542
- zilog 543
- zilog device data 543
- FLL 109
 - electrical characteristics 626
- FPCONFIG register 541
- FPS register 539
- frequency locked loop 109
 - FLL operation 110
 - operating modes 109
- FSTAT register 538

G

- gated mode 181
- General-Purpose Input/Output 55
- GPIO 5
 - alternate functions 56
 - architecture 56
 - external clock setup 57
 - high frequency crystal oscillator override 57
 - input data sample timing 627
 - interrupts 85
 - low-frequency crystal oscillator override 57
 - port A–C pull-up enable subregisters 91, 92
 - port A–H address registers 86
 - port A–H alternate function subregisters 88
 - port A–H control registers 87
 - port A–H data direction subregisters 87
 - port A–H high drive enable subregisters 89
 - port A–H input data registers 94
 - port A–H output control subregisters 88
 - port A–H output data registers 95
 - port A–H stop mode recovery subregisters 90
 - port availability by device 55
 - port input timing 627
 - port output timing 628
 - shared reset pin 57

H

- H 583
- HALT 585

- Halt Mode
 - low-power modes 51
 - halt mode 585
 - hexadecimal number prefix/suffix 583
 - HFXO 57, 104
 - high frequency crystal oscillator
 - electrical characteristics 624
 - high-frequency crystal oscillator 104
 - operating modes 105
 - operation 105
- I**
- I2C 5
 - 10-bit address transaction 314
 - architecture 306
 - baud high and low byte registers 332, 334, 339
 - block diagram 307
 - control register 331
 - control register definitions 329
 - controller signals 18
 - data register 329
 - general call 320
 - interrupts 309
 - master address-only transactions 312
 - master arbitration 311
 - master read transaction, 10-bit address 317
 - master read transaction, 7-bit address 316
 - master read transaction, data DMA 327
 - master transaction diagrams 312
 - master transactions 311
 - master write transaction, 10-bit address 314
 - master write transaction, 7-bit address 313
 - master write transaction, data DMA 326
 - Master/Slave Controller 306
 - master/slave controller registers 307
 - multimaster/multislave system 311
 - operation 308
 - receive interrupts 309
 - SDA and SCL signals 308
 - single master/one or more slaves 311
 - slave address match interrupts 309
 - slave read transaction, data DMA 328
 - slave receive transaction, 10-bit address 322
 - slave receive transaction, 7-bit address 321
 - slave transaction diagrams 320
 - slave transactions 319
 - slave transmit transaction with 7-bit address 323
 - slave write transaction, data DMA 328
 - software address recognition 320
 - software control, transactions 311
 - start byte address recognition 320
 - stop and start conditions 311
 - transactions, DMA control of 326
 - transmit interrupts 309
 - IM 582
 - immediate data 582
 - immediate operand prefix 583
 - INC 584
 - increment 584
 - increment word 584
 - INCW 584
 - indexed 582
 - indirect address prefix 583
 - indirect register 582
 - indirect register pair 582
 - indirect working register 582
 - indirect working register pair 582
 - initialization vector register, AES 436
 - initialization vector, AES 429
 - input modes, ADC 441
 - input path block diagram 172
 - instruction classes, eZ8 CPU 583
 - instruction set
 - eZ8 CPU 580
 - object code 580
 - pseudo-operations 580
 - source, destination 581
 - instructions
 - ADC 584
 - ADCX 584
 - ADD 584
 - ADDX 584
 - AND 586
 - ANDX 586
 - arithmetic 584
 - BCLR 585

BIT 585
 bit manipulation 585
 block transfer 585
 BRK 587
 BSET 585
 BSWAP 585, 587
 BTJ 587
 BTJNZ 587
 BTJZ 587
 CALL 587
 CCF 585
 CLR 586
 COM 586
 CP 584
 CPC 584
 CPCX 584
 CPU control 585
 CPX 584
 DA 584
 DEC 584
 DECW 584
 DI 585
 DJNZ 587
 EI 585
 HALT 585
 INC 584
 INCW 584
 IRET 587
 JP 587
 LD 586
 LDC 586
 LDCI 585, 586
 LDE 586
 LDEI 585
 LDX 586
 LEA 586
 load 586
 logical 586
 MULT 584
 NOP 585
 OR 586
 ORX 586
 POP 586
 POPX 586
 program control 587
 PUSH 586
 PUSHX 586
 RCF 585
 RET 587
 RL 587
 RLC 587
 rotate and shift 587
 RR 587
 RRC 587
 SBC 584
 SCF 585
 SRA 587
 SRL 587
 SRP 585
 stop 586
 SUB 584
 SUBX 584
 SWAP 587
 TCM 585
 TCMX 585
 TM 585
 TMX 585
 TRAP 587
 watchdog timer refresh 586
 XOR 586
 XORX 586
 internal precision oscillator – see IPO 107
 interrupt control register 148
 interrupt controller 127, 132
 architecture 130
 block diagram 130
 interrupt assertion types 131
 interrupt vectors and priority 131
 operation 130
 register definitions 132
 software interrupt assertion 132
 interrupt edge select register 145
 interrupt request 0 register 132
 interrupt request 1 register 134
 interrupt request 2 register 135
 interrupt request 3 register 136
 interrupt return 587
 interrupt vector listing 127

- interrupts
 - ADC and DMA 451
 - and DMA, DAC 470
 - ESPI 293
 - I2C 309
 - LCD controller 519
 - multi-channel timer 192
 - UART 250
- IPO
 - clock system 107
 - electrical characteristics 623
 - operation 107
- IR 582
- Ir 582
- IRET 587
- IRQ0 enable high and low bit registers 137
- IRQ1 enable high and low bit registers 139, 140
- IRQ2 enable high and low bit registers 142
- IRR 582
- Irr 582

- J**
- JP 587
- jump, conditional, relative, and relative conditional 587

- K**
- key register, AES 436

- L**
- LCD
 - alternating between banks 505
 - blanking the display 505
 - electrical characteristics 620
 - voltage doubler 509
 - voltage tripler 509
- LCD controller
 - 1/2 duty mode 512
 - 1/3 duty mode 514
 - 1/4 duty mode 517
 - architecture 503
 - bias generator selection 509
 - blinking and blanking 508
 - block diagram 504
 - clock register 522
 - contrast control 518
 - control 0 register 523
 - control 1 register 524
 - control 2 register 526
 - control 3 register 527
 - display memory 505
 - display memory bank A subregisters 528
 - display memory bank B subregisters 528
 - display memory banks A and B 505
 - display memory organization 506
 - frame timing 507
 - internal charge pump 509
 - interrupts 519
 - operation 504
 - outputs 510
 - register definitions 519
 - registers and subregisters 505
 - static mode 511
 - Stop Mode operation 519
 - subaddress register 520
 - subdata register 521
 - using the LCD as a timer 508
 - VLCD and bias generator source selection 510
 - voltage and bias generation 509
 - waveform generation 510
 - writing the display memory 505
- LCD voltage and bias generation block diagram 509
- LD 586
- LDC 586
- LDCI 585, 586
- LDE 586
- LDEI 585, 586
- LDX 586
- LEA 586
- LFXO 57, 106
- LIN master mode operation, UART 241
- LIN mode initialization, UART 240
- LIN mode operation, UART 240
- LIN protocol mode, UART 239

- LIN slave operation 242
 - UART 242
- LIN sleep mode, UART 241
- LIN sleep state 242
- LIN system clock requirements, UART 240
- Liquid Crystal Display Controller 503
- load 586
- load constant 585
 - to/from program memory 586
 - with auto-increment addresses 586
- load effective address 586
- load external data 586
 - to/from data memory and auto-increment addresses 585, 586
- load instructions 586
- load using extended addressing 586
- logical AND 586
 - extended addressing 586
- logical exclusive OR 586
 - extended addressing 586
- logical instructions 586
- logical OR 586
 - extended addressing 586
- low voltage detect
 - electrical characteristics 619
- low-frequency crystal oscillator 106
 - electrical characteristics 625
 - operation 106
- low-power modes 50
 - Halt Mode 51
 - peripheral-level power control 52
 - power control register definitions 52
 - Stop Mode 50

M

- master interrupt enable 130
- master operation, ESPI 290
- master-in, slave-out 283
- master-out, slave-in 283
- memory
 - endpoint buffer, USB 341
 - program 24
- message frames 239

- MISO 283
- mode
 - capture 181, 182
 - capture/compare 181
 - gated 181
 - PWM 181, 182
- module setup, USB 344
- MOSI 283
- MULT 584
- multi-channel timer 187
 - address map 195
 - application examples 193
 - block diagram 188
 - capture operation 192
 - capture/compare channel operation 191
 - channel status 0–1 registers 202
 - channel-y control registers 203
 - channel-y high and low byte registers 205
 - clock prescaler 189
 - clock source 189
 - continuous compare operation 191
 - control 0 and 1 registers 199
 - control register definitions 195
 - count modulo mode 190
 - count up/down mode 190
 - counter 188
 - DMA 192
 - high and low byte registers 196
 - I/O 188
 - interrupt 192
 - interrupts and DMA 192
 - low-power modes 193
 - mode control 189
 - multiple timer intervals generation 194
 - one-shot compare operation 191
 - operation 188
 - operation in Halt Mode 193
 - operation in Stop Mode 193
 - power reduction during operation 193
 - PWM output operation 191
 - PWM programmable deadband generation 193
 - reload high and low byte registers 197
 - start 189
 - subaddress register 198

- subregisters 0–2 199
- multi-channel timers
 - architecture 187
- multichannel timers
 - signals 20
- multi-master operation, ESPI 291
- multimaster/multislave I2C system 311
- multiply 584
- multiprocessor mode
 - receive inputs, UART 238
 - UART 237

N

- network address 238, 275
- noise filter
 - architecture 255
 - system block diagram 172, 255
 - UART 255
- noise, electrical 440
- Non-Volatile Data Storage – see NVDS 556
- NOP (no operation) 585
- notation
 - b 582
 - cc 582
 - DA 582
 - ER 582
 - IM 582
 - IR 582
 - Ir 582
 - IRR 582
 - Irr 582
 - p 582
 - R 582
 - r 582
 - RA 582
 - RR 582
 - rr 582
 - vector 582
 - X 582
- NVDS
 - byte read 557
 - byte write 556
 - code interface 556

- electrical characteristics 608
 - and timing 608
- operation 556
- optimizing memory usage for execution speed 559
- power failure protection 558

O

- object code, instruction set 580
- OCD
 - architecture 560
 - auto-baud detector/generator 564
 - automatic reset 567
 - baud reload register 578
 - block diagram 560
 - breakpoints 568
 - commands 569
 - control register 575
 - control register definitions 575
 - counter register 568
 - data format 564
 - DBG pin to RS-232 Interface 562
 - debug mode 563
 - debugger break 587
 - high-speed synchronous communication 565
 - interface 561, 562
 - line control register 577
 - operation 561
 - reset and go 575
 - reset and stop 575
 - serial errors 566
 - signals 21
 - status register 577
 - timing 629
 - transmit flow control 567
 - wire and 567
- OCD commands
 - execute instruction (12h) 574
 - read baud reload register (1Bh) 574
 - read data memory (0Dh) 573
 - read line control register (19h) 574
 - read OCD control register (05h) 571
 - read OCD counter register (03h) 571

- read OCD status register (02h) 571
- read program counter (07h) 572
- read program memory (0Bh) 573
- read program memory CRC (0Eh) 573
- read register (09h) 572
- read revision (00h) 571
- step instruction (10h) 574
- stuff instruction (11h) 574
- write data memory (0Ch) 573
- write line control register (18h) 574
- write OCD control register (04h) 571
- write OCD counter register (01h) 571
- write program counter (06h) 572
- write program memory (0Ah) 572
- write register (08h) 572
- OFB mode encryption example, AES 431
- On-Chip Debugger – see OCD 560
- Op Amp A 477
 - block diagram 475
- Op Amp B 478
 - block diagram 476
- op amps
 - A Control 0 Register 480
 - A Control 1 Register 482
 - architecture 474
 - B Control 0 Register 483
 - B Control 1 Register 484
 - control register definitions 480
 - electrical characteristics 617
 - operation 476
- op code maps 597
 - abbreviations 598
 - first 599
 - second after 1Fh 600
- operation
 - ADC 440
 - AES 425
 - comparators 489
 - current measurement 504
 - DAC 467
 - DMA controller 391
 - ESPI 284
 - Flash memory 531
 - Flash option bits 542
 - I2C 308
 - LCD controller 504
 - NVDS 556
 - OCD 561
 - op amps 476
 - reference system 491
 - temperature sensor 500
 - UART 256
 - USB 341
 - Operational Amplifiers – see op amps 474
 - OR 586
 - Ordering Information 633
 - ORX 586
 - oscillator
 - signals 20
 - output feedback (OFB) mode, AES 430
 - overrun errors, UART-LDD 252
 - overview, USB registers and subregisters 341
- P**
 - p 582
 - Packaging 632
 - part numbers
 - suffix designations 636
 - part selection guide 2
 - PC 583
 - Phase Locked Loop – see PLL 112
 - pin characteristics 22
 - pin configurations 12
 - Pin Descriptions 12
 - PLL
 - block diagram 112
 - electrical characteristics, oscillator 625
 - operation 112
 - polarity 582
 - POP 586
 - using extended addressing 586
 - POPX 586
 - port availability, device 55
 - port input timing (GPIO) 627
 - port output timing, GPIO 628
 - power control, DAC 469
 - power supply

- signals 21
- power-on reset (POR) 40
- precharacterization 638
- program control instructions 587
- program counter 583
- program memory 24
- programmable gain 6, 474, 477, 480, 482
- programming Flash memory 534
- protocol configuration, ESPI 289
- pseudo-operations, instruction set 580
- PUSH 586
 - using extended addressing 586
- PUSHX 586
- PWM Mode 181, 182

R

- R 582
- r 582
- RA
 - register address 582
- RCF 585
- real-time clock 210, 226
 - alarm 211
 - alarm control register 226
 - alarm day-of-the-week register 224, 226
 - alarm hours register 223
 - alarm minutes register 222
 - alarm seconds register 221
 - block diagram 210
 - calendar mode operation 211
 - control register 228
 - count register writing 212
 - counter mode operation 211
 - counts, synchronous reading of 212
 - day-of-the-month register 219
 - day-of-the-week register 216
 - enable 212
 - hours register 215
 - minutes register 214
 - month register 219
 - power-on reset 213, 214, 215, 216, 218, 219, 220, 221, 222, 223, 224, 225, 226, 227
 - recommended operation 212
 - seconds register 213
 - source selection 211
 - timing register 227
 - year register 220
- receive data register, UART-LDD 258
- receiver interrupts, UART 251
- receiving UART data-interrupt-driven method 235
- receiving UART data-pollled method 234
- reference system
 - block diagram 488
 - electrical characteristics and timing 615
 - operation 491
- references, ADC 446
- register 120, 582
 - ADC control 0 452
 - ADC control 1 454
 - ADC control 2 454
 - ADC data high 460
 - ADC data low 460
 - ADC input select high 455
 - ADC input select low 456
 - ADC offset calibration 459
 - ADC sample time 461
 - ADC window lower threshold high 464
 - ADC window lower threshold low 465
 - ADC window upper threshold high 462
 - ADC window upper threshold low 463
 - AES data 435
 - baud low and high byte, I2C 332, 334, 339
 - baud rate high and low byte, ESPI 303
 - clock control 0 114
 - clock control 1 116
 - clock control 2 117
 - clock control 3 118
 - clock control 4 119
 - clock control 6 121
 - clock control 7 122
 - clock control 8 122
 - clock control 9 123
 - clock control A 123
 - clock control B 125
 - clock control C 126
 - comparator
 - 0 control 0 495

- 0 control 1 496
- 1 control 0 497
- 1 control 1 498
- comparator control 494
- comparators and reference system definitions 493
- control, I2C 331
- DAC control 470
- DAC data high 472
- DAC data low 472
- data, ESPI 295
- DMA 0–3 subaddress/status 400
- DMA 0–3 subdata 401
- DMA global control 402
- event system, destination subaddress 421
- event system, destination subdata 422
- event system, source subaddress 418
- event system, source subdata 419
- Flash block protect 540
- Flash control 537
- Flash page select 539
- Flash programming configuration 541
- Flash status 538
- I2C control definitions 329
- I2C master/slave controller 307
- interrupt request 0 132
- interrupt request 1 134
- interrupt request 2 135
- interrupt request 3 136
- LCD clock 522
- LCD control 0 523
- LCD control 1 524
- LCD control 2 526
- LCD control 3 527
- LCD subaddress 520
- LCD subdata 521
- mode, ESPI 299
- OCD baud reload 578
- OCD control 575
- OCD line control 577
- OCD status 577
- Op Amp A Control 0 480
- Op Amp A Control 1 482
- Op Amp B Control 0 483
- Op Amp B Control 1 484
- real-time clock timing 227
- SPI data (SPIDATA) 481, 494, 495
- status, ESPI 301
- timer 0–2 noise filter control (TxNFC) 186
- transmit data command, ESPI 296
- trim bit data 546
- USB 341
- USB control 360
- USB DMA 0–1 control 361
- USB DMA data 362
- USB interrupt control 363
- USB subdata 359
- watchdog timer reload high byte (WDTH) 209
- watchdog timer reload low byte (WDTL) 209
- register definitions 132
 - ADC control 452
 - AES 434
 - clock system 114
 - comparators and reference system 493
 - DMA control 213, 399
 - ESPI control 295
 - event system 417
 - Flash memory control 537
 - I2C control 329
 - LCD controller 519
 - multi-channel timer 195
 - OCD control 575
 - op amps 480
 - power control 52
 - reset 48
 - timer control 174
 - UART-LDD control 258
 - USB control 356
- register file 24
- register pair 582
- register pointer 583
- register, USB subaddress 357
- registers
 - ADC channel 1 520, 521, 522
 - ADC data high byte 523, 524, 526
 - ADC data low bit 464, 465, 472, 527, 528
- reset
 - carry flag 585

- low-voltage detection 47
- power-on reset 40
- register definitions 48
- stop-mode recovery 44
- system 39
- system reset 39
- types 38
- watchdog timer 43
- reset and go, OCD 575
- reset and stop, OCD 575
- Reset, Stop-Mode Recovery and Low-Voltage Detection 38
- response 239, 243
- RET 587
- return 587
- RL 587
- RLC 587
- rotate and shift instructions 587
- rotate left 587
- rotate left through carry 587
- rotate right 587
- rotate right through carry 587
- RP 583
- RR 582, 587
- rr 582
- RRC 587
- RSTSTAT register
 - voltage brown-out reset 42

S

- saturated state output 172, 255
- saturated state, UART-LDD operation 256
- SBC 584
- SCF 585
- SCK 283
- SDA and SCL signals, I2C 308
- second op code map after 1Fh 600
- serial clock, ESPI 283
- serial peripheral interface, enhanced – see ESPI 281
- set carry flag 585
- set register pointer 585
- shift right arithmetic 587
- shift right logical 587
- signal descriptions 18
- signals, ESPI 283
- single master/one or more slave I2C system 311
- single-shot, ADC 444
- slave I2S mode select, ESPI 289
- slave operation, ESPI 291
- slave select 425
 - modes of operation, ESPI 287
- slave select, ESPI 283
- slave transactions, I2C 319
- Sleep state 242
- sleep state 241
- software control, I2C transactions 311
- software trap 587
- source operand 583
- source selection
 - event system 412
- source, destination – instruction set 581
- SP 583
- special modes, UART 237
- SPI
 - signals 283
- SPI controller
 - signals 19
- SPIDATA register 481, 494, 495
- SRA 587
- src 583
- SRL 587
- SRP 585
- SS 283
- stack pointer 583
- starting a conversion, DAC 468
- status per event
 - reset 49
- status register
 - AES 438
- stop 586
- Stop Mode 586
 - low-power modes 50
 - operation, LCD controller 519
- stop-mode recovery 46, 47
- stop-mode recovery characteristics and latency
 - reset 39
- SUB 584

subregister

- DMA destination address 404
 - DMA source address 403
 - event system, channel 0–7 source 420
 - event system, destination 0–3F channel 423
 - LCD display memory bank A 528
 - LCD display memory bank B 528
 - USB
 - setup buffer byte 0–7 389
 - USB clock gate 367
 - USB control and status 380
 - USB endpoint 0 control and status 375
 - USB endpoint pairing 385
 - USB frame count 382
 - USB function address 384
 - USB IN 0–3 byte count 376
 - USB IN 1–3 control and status 377
 - USB IN endpoint 1–3 start address 366
 - USB IN endpoint valid 386
 - USB IN endpoints start address 365
 - USB IN endpoints stop address 388
 - USB IN interrupt enable 372
 - USB IN interrupt request 369
 - USB interrupt identification 368
 - USB OUT 0–3 byte count 378
 - USB OUT 1–3 control and status 379
 - USB OUT endpoint 1–3 start address 364
 - USB OUT endpoint valid 387
 - USB OUT interrupt enable 373
 - USB OUT interrupt request 370
 - USB protocol interrupt enable 374
 - USB protocol interrupt request 371
 - USB toggle control 381
- subtract 584
- extended addressing 584
 - with carry 584
- SUBX 584
- SWAP 587
- swap nibbles 587
- symbols, additional 583
- system reset 39
- reset 39

T

- TCM 585
- TCMX 585
- Temperature Sensor 500
- temperature sensor
 - calibration 502
 - electrical characteristics 616
 - operation 500
- test complement under mask 585
- test complement under mask - extended addressing 585
- test under mask 585
- test under mask - extended addressing 585
- timer
 - block diagram 150
- timer input path and noise filter
 - architecture 172
 - block diagram 172
 - operation 172
- timers 149
 - architecture 150
 - capture mode 162, 181, 182
 - capture/compare mode 166, 181
 - compare mode 164
 - continuous mode 156
 - counter mode 157
 - gated mode 165, 181
 - operating modes 152
 - PWM Mode 159, 160, 181, 182
 - reading the timer count values 170
 - reload high and low byte registers 176
 - signals 19
 - timer control register definitions 174
 - timer input path and noise filter 171
 - timer interrupts and DMA 170
 - timer output signal operation 171
- timers 0–2
 - control registers 179, 180, 184, 185
 - high and low byte registers 175, 177, 178
- timing
 - ADC 447
- timing considerations
 - event system 415
- TM 585

TMX 585
 transactions, I2C master 311
 transfer in list DMA option 396
 transmit data command register, ESPI 296
 transmit data register, UART-LDD 258
 transmitting UART data-interrupt-driven method
 233
 transmitting UART data-polled method 232
 TRAP 587
 TRMDR register 546
 TxNFC register 186

U

UART 5, 242

- baud rate generator 254
- baud rate generator interrupts 253
- clear to send operation 236
- control register definitions 258
- DALI clock requirements 244
- DALI mode initialization 245
- DALI mode operation 245
- DALI protocol mode 243
- DALI receive during Stop Mode 247
- DALI receive operation 246
- DALI transmit operation 245
- data format 232
- DMX clock requirements 248
- DMX master mode operation 249
- DMX mode initialization 249
- DMX mode operation 249
- DMX protocol mode 247
- DMX slave during Stop Mode 250
- DMX slave operation 249
- external driver enable operation 236
- interrupts 250
- LIN master mode operation 241
- LIN mode initialization 240
- LIN mode operation 240
- LIN protocol mode 239
- LIN sleep mode 241
- LIN sleep state 242
- LIN system clock requirements 240
- multiprocessor mode 237

- receive inputs 238
- noise filter 255
- operation 256
- receiver interrupts 251
- receiving data using interrupt-driven method
 235
- receiving data using the polled method 234
- special modes 237
- transmitting data using the interrupt-driven
 method 233
- transmitting data using the polled method 232

UART controller

- signals 18

UART timing 630

UART-LDD 230

- address compare register 275
- architecture 231
- baud rate high and low byte registers 276
- control 0 register 267
- control 1 registers 269
- DALI control register 273
- data-handling procedure 252
- DMA support 254
- DMX control register 274
- error-handling procedure 252
- LIN control register 272
- mode select and status register 264
- multiprocessor control register 269
- noise filter control register 271
- receive data register 258
- status 0 registers 259
- transmit data register 258

UART-LDD block diagram 231

UART-LDD overrun errors 252

unity gain 474, 475, 478

- bandwidth 476, 482, 485
- buffer 477

Universal Serial Bus 340

usage examples

- event system 415

USB

- architecture 340
- bulk IN transfers 348
- bulk OUT transfers 349

- clock gate subregister 367
 - control and status subregister 380
 - control read 346
 - control register 360
 - control register definitions 356
 - control transfers using endpoint 0 345
 - control write 345
 - device-initiated resume 353
 - DMA 0–1 control registers 361
 - DMA data register 362
 - electrical characteristics 623
 - endpoint 0 control and status subregister 375
 - endpoint buffer memory 341
 - endpoint pairing 350
 - endpoint pairing subregister 385
 - frame count subregisters 382
 - frame number 352
 - function address 350
 - function address subregister 384
 - host-initiated resume 354
 - IN 0–3 byte count subregisters 376
 - IN 1–3 control and status subregister 377
 - IN endpoint 1–3 start address subregisters 366
 - IN endpoint valid subregister 386
 - IN endpoints start address subregister 365
 - IN endpoints stop address subregister 388
 - IN interrupt enable subregister 372
 - IN interrupt request subregister 369
 - interrupt control register 363
 - interrupt identification subregister 368
 - module setup 344
 - operation 341
 - OUT 0–3 byte count subregisters 378
 - OUT 1–3 control and status subregisters 379
 - OUT endpoint 1–3 start address subregisters 364
 - OUT endpoint valid subregister 387
 - OUT interrupt enable subregister 373
 - OUT interrupt request subregister 370
 - protocol interrupt enable subregister 374
 - protocol interrupt request subregister 371
 - registers and subregisters, overview 341
 - remote wake-up 353
 - reset bus state 352
 - setting valid endpoints 344
 - setup buffer 347
 - setup buffer byte 0–7 subregisters 389
 - SOF frame number 352
 - subaddress register 357
 - subdata register 359
 - suspend 353
 - suspend/resume 352
 - toggle control 351
 - toggle control subregister 381
 - transfer control 351
 - transfers using endpoints 1–3 348
 - USB – see Universal Serial Bus 340
 - USB block diagram 340
 - using a GPIO port pin transition
 - reset 47
 - using a watchdog timer time-out
 - reset 46
 - using an external RESET pin
 - reset 47
 - using the comparator 46
 - using the LVD interrupt
 - reset 46
 - using the RTC 46
 - using the timer 46
- V**
- vector 582
 - voltage brown-out
 - reset 42
 - voltage doubler 509
 - voltage doubler, LCD 509
 - voltage references, DAC 469
 - voltage tripler, LCD 509
- W**
- watchdog timer 206
 - approximate time-out delay 206
 - electrical characteristics and timing 607
 - interrupt, normal operation 207
 - interrupt, Stop Mode 207

operation 206
refresh 586
reload unlock sequence 208
reload upper, high and low registers 208
reset 43
reset in normal operation 207
reset in Stop Mode 208
retrigger 207
time-out response 207
timer register definitions 208
watchdog timer oscillator 108
WDTH register 209
WDTL register 209
window detection, ADC 450
working register 582
working register pair 582
WTO 108

X

X 582
XOR 586
XORX 586



Customer Support

To share comments, get your technical questions answered, or report issues you may be experiencing with our products, please visit Zilog's Technical Support page at <http://support.zilog.com>.

To learn more about this product, find additional documentation, or to discover other facets about Zilog product offerings, please visit the Zilog Knowledge Base at <http://zilog.com/kb> or consider participating in the Zilog Forum at <http://zilog.com/forum>.

This publication is subject to replacement by a later edition. To determine whether a later edition exists, please visit the Zilog website at <http://www.zilog.com>.