

LCD MODULE SPECIFICATION

Customer: _____
Model Name: ZJ050NA-08C
Date: 2013/04/24
Version: 01

Preliminary Specification

Final Specification

For Customer's Acceptance

| Approved by | Comment |
|-------------|---------|
| | |

| Approved by | Reviewed by | Prepared by |
|-----------------------------|-----------------|------------------|
| Stanely CW Leung | Green Fu | David Lee |

Record of Revision

| Version | Revise Date | Page | Content |
|-------------|-------------|------|-----------------|
| Pre-Spec.01 | 2013/04/24 | All | Initial Release |

Contents

| | |
|--|----|
| 1. General Specifications | 1 |
| 2. Pin Assignment | 2 |
| 3. Operation Specifications..... | 4 |
| 3.1. Electrical Absolute Maximum Ratings | 4 |
| 3.2. Typical Operation Conditions | 5 |
| 3.2.1. Typical Operation Conditions | 5 |
| 3.2.2 Current Consumption..... | 6 |
| 3.2.3 Backlight Driving Conditions..... | 6 |
| 3.3. Power Sequence..... | 7 |
| 3.4. Timing Characteristics | 8 |
| 3.4.1. Timing Conditions | 8 |
| 3.4.2. Timing Diagram..... | 10 |
| 4. Optical Specification | 13 |
| 5. Reliability Test..... | 17 |
| 6. General Precautions | 18 |
| 6.1. Safety | 18 |
| 6.2. Handling | 18 |
| 6.3. Static Electricity..... | 18 |
| 6.4. Storage | 18 |
| 6.5. Cleaning..... | 18 |
| 7. Mechanical Drawing..... | 19 |
| 8. Package Drawing..... | 20 |
| 8.1. Packaging Material Table | 20 |
| 8.2. Packaging Quantity..... | 20 |

1. General Specifications

| No. | Item | Specification | Remark |
|-----|-----------------------------|-----------------------------------|--------|
| 1 | LCD size | 5.0 inch(Diagonal) | |
| 2 | Driver element | a-Si TFT active matrix | |
| 3 | Resolution | 640 ×(RGB) × 480 | |
| 4 | Display mode | Normally White, Transmissive | |
| 5 | Dot pitch | 0.053(W) × 0.159(H) mm | |
| 6 | Active area | 101.57(W) × 76.18(H) mm | |
| 7 | Module size | 117.65(W) × 88.43(H) × 5.70(D) mm | Note 1 |
| 8 | Surface treatment | Anti-Glare | |
| 9 | Color arrangement | RGB-stripe | |
| 10 | Interface | Digital | |
| 11 | Backlight Power consumption | 0.960W (Typ.) | |
| 12 | Panel Power consumption | TBD | |
| 13 | Weight | TBD | |

Note 1: Refer to Mechanical Drawing.

2. Pin Assignment

TTL connector is used for the module electronics interface. The recommended model is FH12S-50S-0.5SH manufactured by HiRose.

| Pin No. | Symbol | I/O | Function | Remark |
|---------|-------------------|-----|---------------------------|--------|
| 1 | V _{LED+} | P | Power for LED Circuit | |
| 2 | V _{LED+} | P | Power for LED Circuit | |
| 3 | V _{LED-} | P | Power for LED Circuit | |
| 4 | V _{LED-} | P | Power for LED Circuit | |
| 5 | GND | P | Power ground | |
| 6 | V _{COM} | I | V _{COM} input | |
| 7 | DV _{DD} | P | Power for Digital Circuit | |
| 8 | MODE | I | DE or HV mode control | Note1 |
| 9 | DE | I | Data Enable | |
| 10 | VS | I | Vsync signal input | |
| 11 | HS | I | Hsync signal input | |
| 12 | B7 | I | Blue data input (MSB) | |
| 13 | B6 | I | Blue data input | |
| 14 | B5 | I | Blue data input | |
| 15 | B4 | I | Blue data input | |
| 16 | B3 | I | Blue data input | |
| 17 | B2 | I | Blue data input | |
| 18 | B1 | I | Blue data input | |
| 19 | B0 | I | Blue data input(LSB) | |
| 20 | G7 | I | Green data input(MSB) | |
| 21 | G6 | I | Green data input | |
| 22 | G5 | I | Green data input | |
| 23 | G4 | I | Green data input | |
| 24 | G3 | I | Green data input | |
| 25 | G2 | I | Green data input | |
| 26 | G1 | I | Green data input | |
| 27 | G0 | I | Green data input(LSB) | |
| 28 | R7 | I | Red data input(MSB) | |
| 29 | R6 | I | Red data input | |
| 30 | R5 | I | Red data input | |
| 31 | R4 | I | Red data input | |
| 32 | R3 | I | Red data input | |
| 33 | R2 | I | Red data input | |
| 34 | R1 | I | Red data input | |

| | | | | |
|----|------------------|---|---|-------|
| 35 | R0 | I | Red data input(LSB) | |
| 36 | GND | P | Power ground | |
| 37 | DCLK | I | Sample clock | |
| 38 | GND | P | Power ground | |
| 39 | L/R | I | Select left to right scanning direction | Note2 |
| 40 | U/D | I | Select up or down scanning direction | Note2 |
| 41 | VGH | I | Positive power for scan driver | |
| 42 | VGL | I | Negative power for scan driver | |
| 43 | AV _{DD} | P | Power for Analog Circuit | |
| 44 | RESET | I | Reset | |
| 45 | NC | - | No Connector | |
| 46 | V _{COM} | I | V _{COM} input | |
| 47 | NC | - | No Connector | |
| 48 | NC | - | No Connector | |
| 49 | NC | - | No Connector | |
| 50 | NC | - | No Connector | |

Note: I: input, O: output, P: Power

Note 1: DE Mode, Mode="H",HS floating and VS floating

HV Mode, Mode="L" and DE floating

Note2: Selection of scanning mode

| Setting of scan control input | | Scanning direction |
|-------------------------------|------------------|---------------------------|
| U/D | L/R | |
| DV _{DD} | DV _{DD} | Up to down, left to right |
| GND | DV _{DD} | Down to up, left to right |
| DV _{DD} | GND | Up to down, right to left |
| GND | GND | Down to up, right to left |

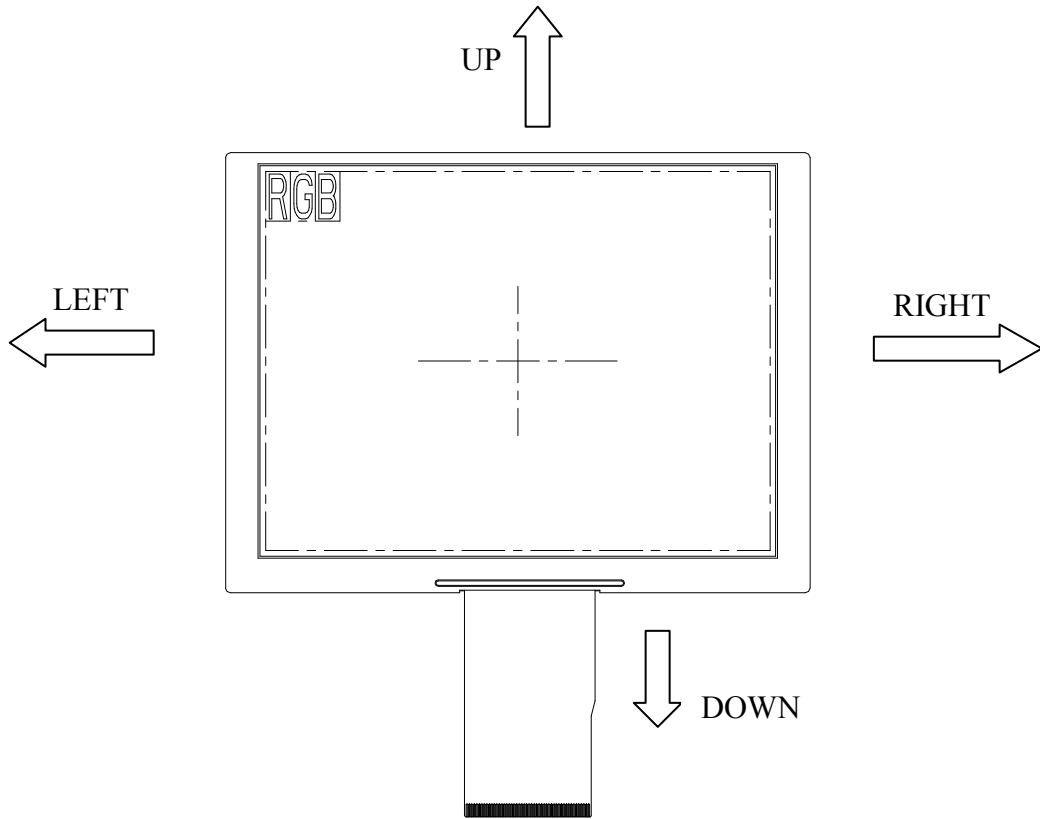

3. Operation Specifications

3.1. Electrical Absolute Maximum Ratings

(GND =0V, Note 1)

| Item | Symbol | Values | | Unit | Remark |
|-----------------------|-----------------|--------|------|------|----------|
| | | Min. | Max. | | |
| Power voltage | DV_{DD} | -0.3 | 5 | V | |
| | AV_{DD} | 6.5 | 13.5 | V | |
| | V_{GH} | -0.3 | 42 | V | |
| | V_{GL} | -20 | 0.3 | V | |
| | $V_{GH}-V_{GL}$ | - | 40 | V | |
| Operation Temperature | T_{OP} | -20 | 70 | °C | |
| Storage Temperature | T_{ST} | -30 | 80 | °C | |
| LED Reverse Voltage | V_r | - | TBD | V | Each LED |
| LED Forward Current | I_f | - | TBD | mA | Each LED |

Note 1: Device is subject to be damaged permanently if stresses beyond those absolute maximum ratings listed above.

Note 2: Vr conditions: Zener Diode 120mA.

3.2. Typical Operation Conditions

3.2.1. Typical Operation Conditions

(GND =0V, Note 2)

| Item | Symbol | Values | | | Unit | Remark |
|--------------------------|------------------|---------------------|------|---------------------|------|--------|
| | | Min. | Typ. | Max. | | |
| Power voltage | DV _{DD} | 3.0 | 3.3 | 3.6 | V | |
| | AV _{DD} | 10.2 | 10.4 | 10.6 | V | |
| | V _{GH} | 16.7 | 17.0 | 17.3 | V | |
| | V _{GL} | -7.3 | -7.0 | -6.7 | V | |
| Input signal voltage | V _{COM} | 3.2 | 3.5 | 3.8 | V | Note 1 |
| Input logic high voltage | V _{IH} | 0.7DV _{DD} | - | DV _{DD} | V | |
| Input logic low voltage | V _{IL} | 0 | - | 0.3DV _{DD} | V | |

Note 1: Typical Vcom is only a reference value, it must be optimized according to each LCM, please use VR and base on below application circuit.

Note 2: Be sure to apply GND, DV_{DD}, and V_{GL}, to the LCD first, and then apply V_{GH}.

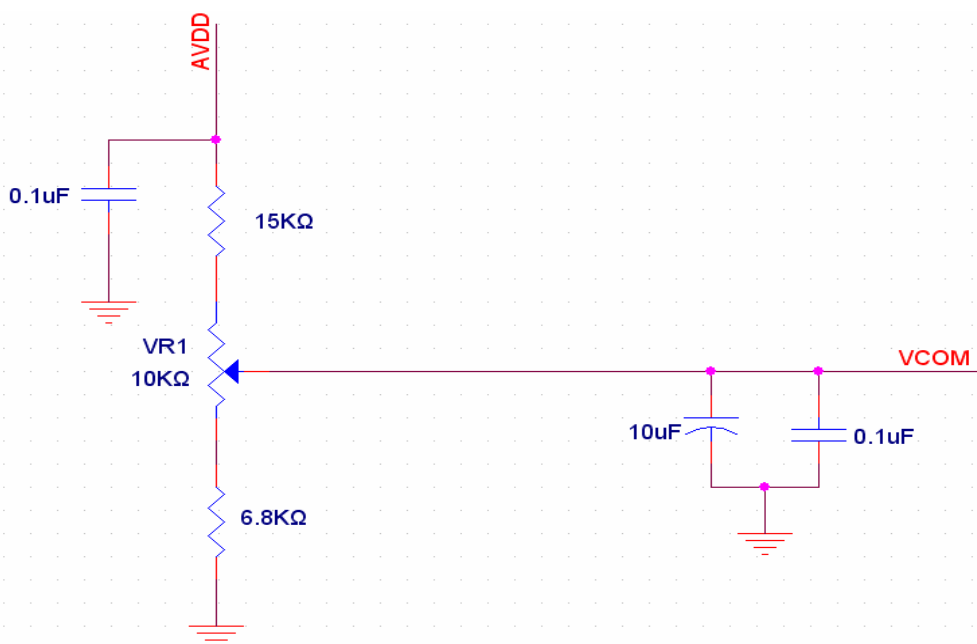

3.2.2 Current Consumption

(GND =0V)

| Item | Symbol | Values | | | Unit | Remark |
|--------------------|----------|--------|------|------|------|-------------------|
| | | Min. | Typ. | Max. | | |
| Current for Driver | I_{GH} | - | TBD | - | uA | $V_{GH} = +17V$ |
| | I_{GL} | - | TBD | - | uA | $V_{GL} = -7V$ |
| | I_{CC} | - | TBD | - | mA | $DV_{DD} = 3.3V$ |
| | I_{DD} | - | TBD | - | mA | $AV_{DD} = 10.4V$ |

3.2.3 Backlight Driving Conditions

| Item | Symbol | Values | | | Unit | Remark |
|---------------------------|--------|--------|------|------|------|--------|
| | | Min. | Typ. | Max. | | |
| Voltage for LED Backlight | V_L | 14.6 | 15.5 | 16.4 | V | Note 1 |
| Current for LED Backlight | I_L | TBD | 60 | TBD | mA | |
| LED life time | - | 15,000 | - | - | Hr | Note 2 |

Note 1: The Voltage for LED Backlight is defined at $T_a = 25^\circ C$ and $I_L = 60mA$.

Note 2: The "LED life time" is defined as the module brightness decrease to 50% original brightness that the ambient temperature is $25^\circ C$ and $I_L = 60mA$. The LED lifetime could be decreased if operating I_L is larger than 60mA.

3.3. Power Sequence

1. Power on:

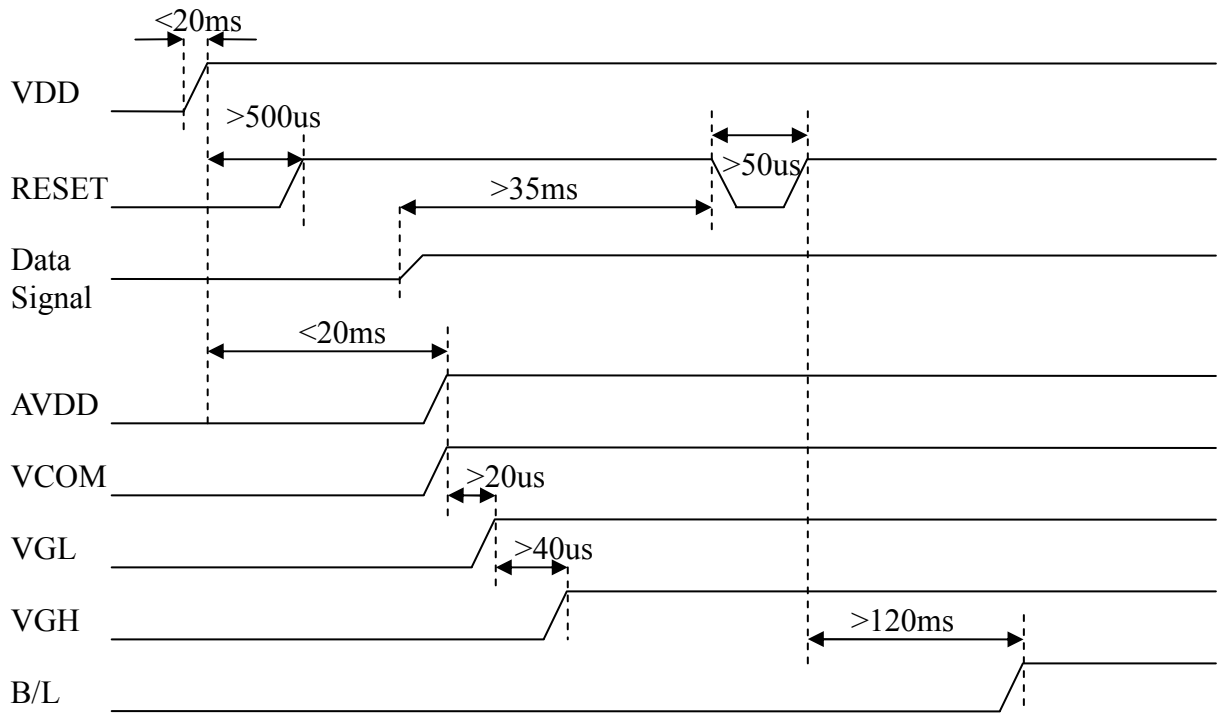

2. Power off:

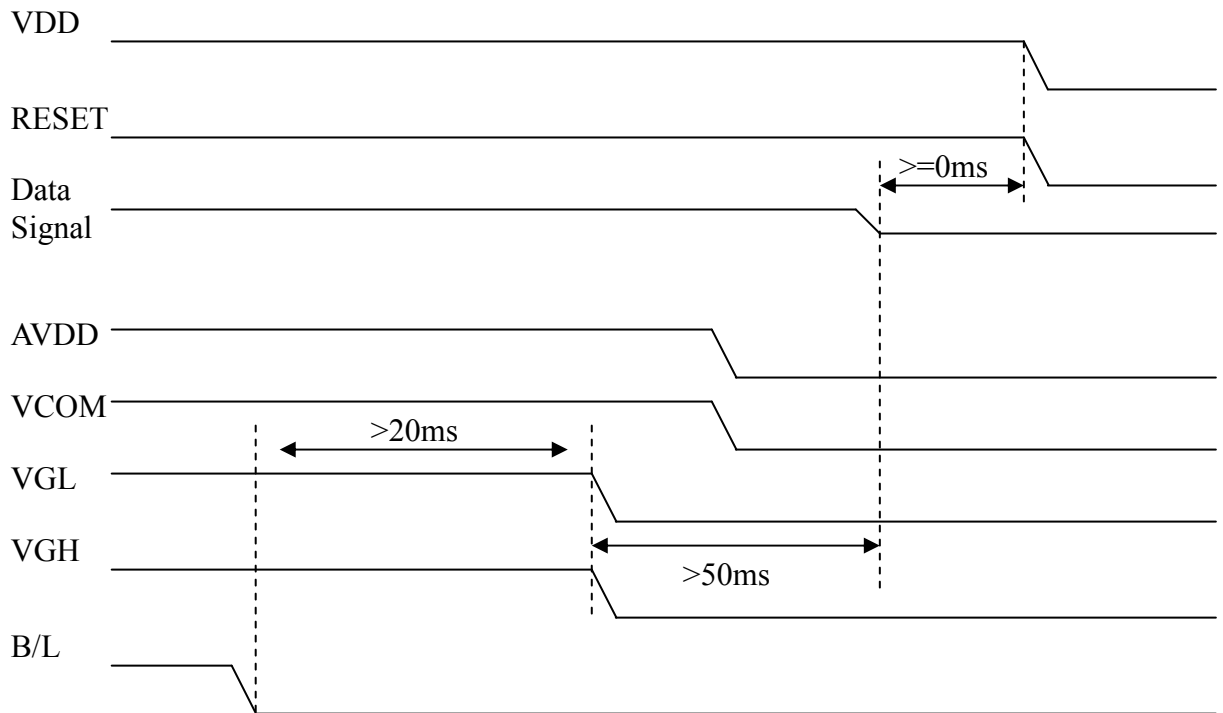

Note: Data includes DE, VS, HS, B0~B7, G0~G7, R0~R7, DCLK.

3.4. Timing Characteristics

3.4.1. Timing Conditions

Input/Output Timing

| Item | Symbol | Values | | | Unit. | Remark |
|-------------------|--------|--------|------|------|-------|----------------|
| | | Min. | Typ. | Max. | | |
| PXLCLK clock time | Tclk | 12.3 | 13.5 | - | ns | 1 Tclk |
| PXLCLK pulse duty | Tcwh | 40 | 50 | 60 | % | Tclk |
| DATA set-up time | Tdsu | 5 | - | - | ns | DATA to PXLCLK |
| DATA hold time | Tdhd | 5 | - | - | ns | DATA to PXLCLK |
| DE setup time | Tesu | 5 | - | - | ns | DE to PXLCLK |
| VSYNC setup time | Tvst | 5 | - | - | ns | |
| VSYNC hold time | Tvhd | 5 | - | - | ns | |
| HSYNC setup time | Thst | 5 | - | - | ns | |
| HSYNC hold time | Thhd | 5 | - | - | ns | |
| HSYNC period time | Th | 22.91 | - | - | us | |
| HSYNC width | Thwh | 1 | - | - | Tclk | |
| VSYNC width | Tvwh | 1 | - | - | Th | |

Input Timing Limitation of DE Mode

| DE Mode | Values | | | Unit | Remark |
|---------|--------|------|------|------|------------|
| | Min. | Typ. | Max. | | |
| THC | 40 | 160 | 480 | tclk | |
| THD | 640 | 640 | 640 | tclk | |
| TH | 680 | 800 | 1100 | tclk | 1TH=1line |
| TVC | 5 | 45 | 220 | Line | |
| TVD | 480 | 480 | 480 | line | |
| TV | 485 | 525 | 700 | line | 1TV=1field |

Input Timing Limitation of HV Mode

| HV Mode | Values | | | Unit | Remark |
|---------|--------|------|------|------|------------|
| | Min. | Typ. | Max. | | |
| Thwh | - | 4 | - | tclk | |
| Thbp | - | 42 | - | tclk | |
| Thfp | - | 114 | - | tclk | |
| THD | - | 640 | - | tclk | |
| TH | - | 800 | - | tclk | |
| Tvwh | - | 3 | - | line | |
| Tvbp | - | 31 | - | line | |
| Tvfp | - | 11 | - | line | |
| TVD | - | 480 | - | line | |
| TV | - | 525 | - | line | 1TV=1field |

3.4.2. Timing Diagram

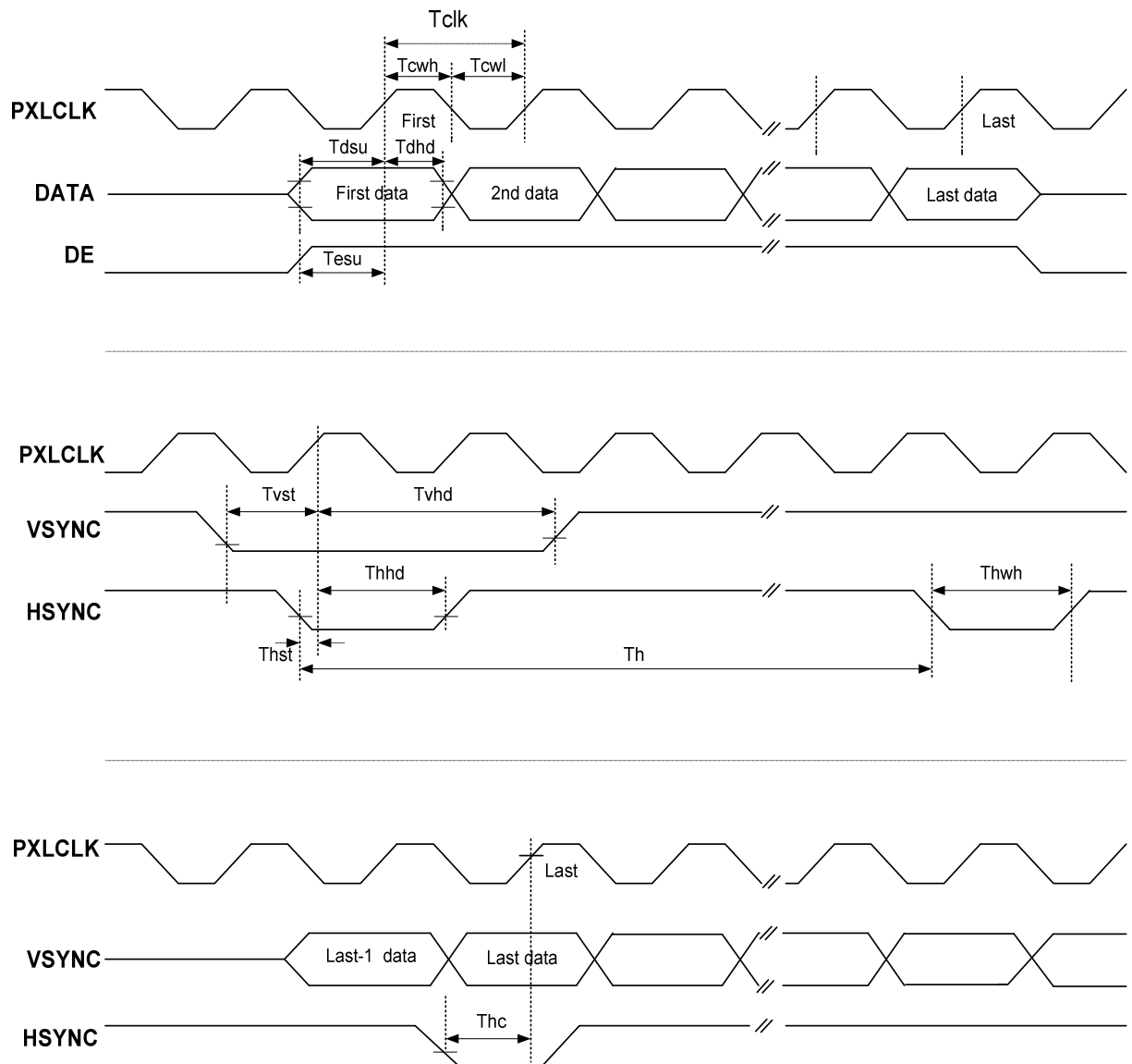

Fig.3-1 Clock and Data Input Timing Diagram

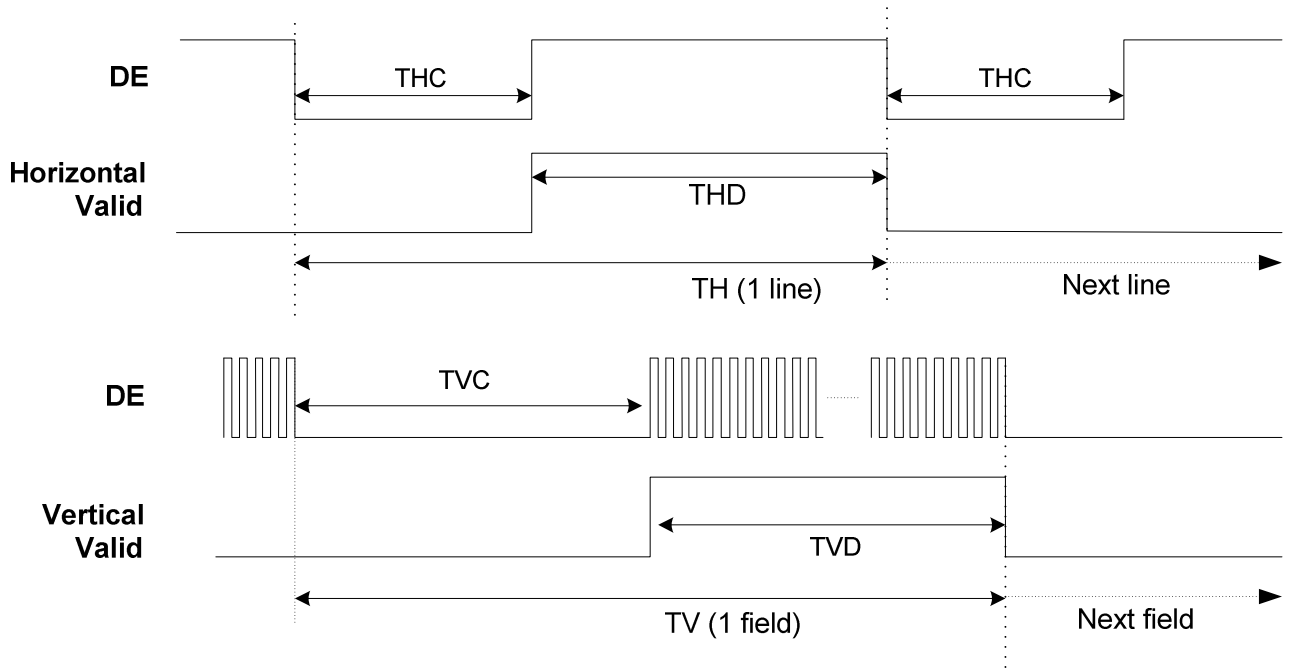

Fig.3-2 DE Mode Input Timing

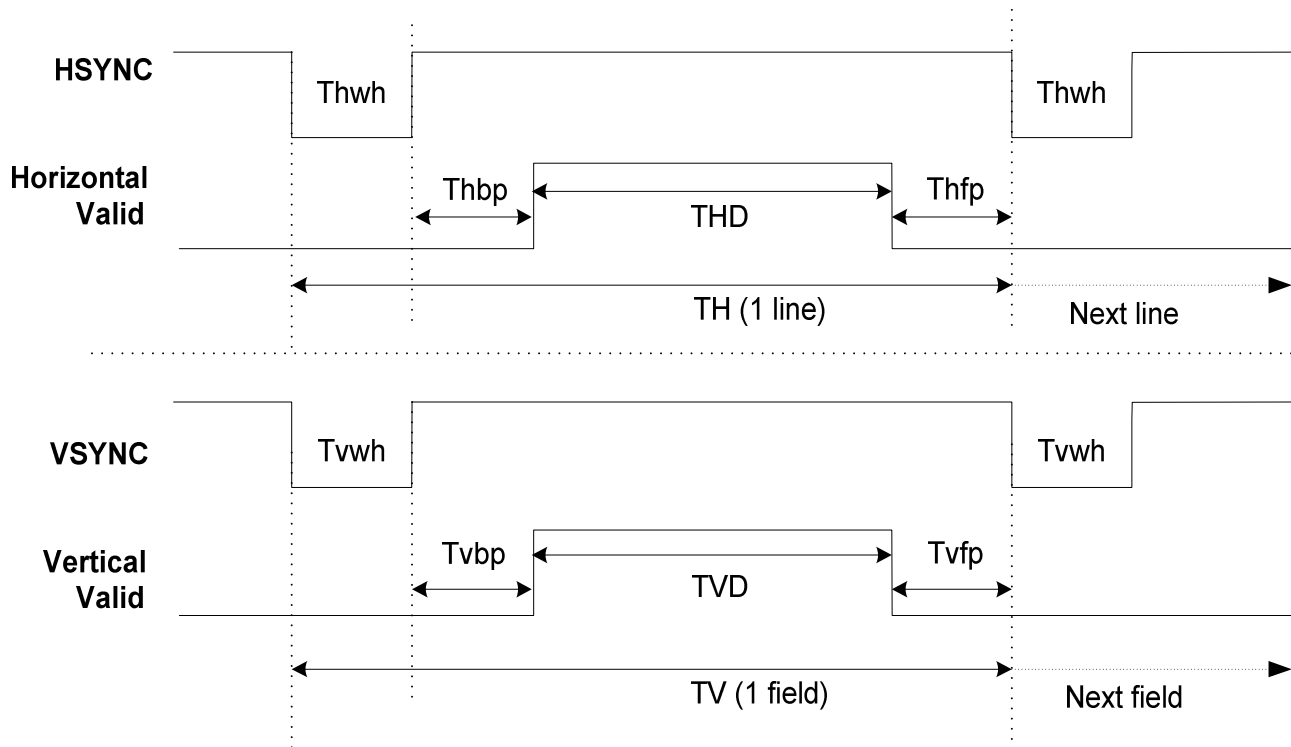

Fig.3-3 HV Mode Input Timing

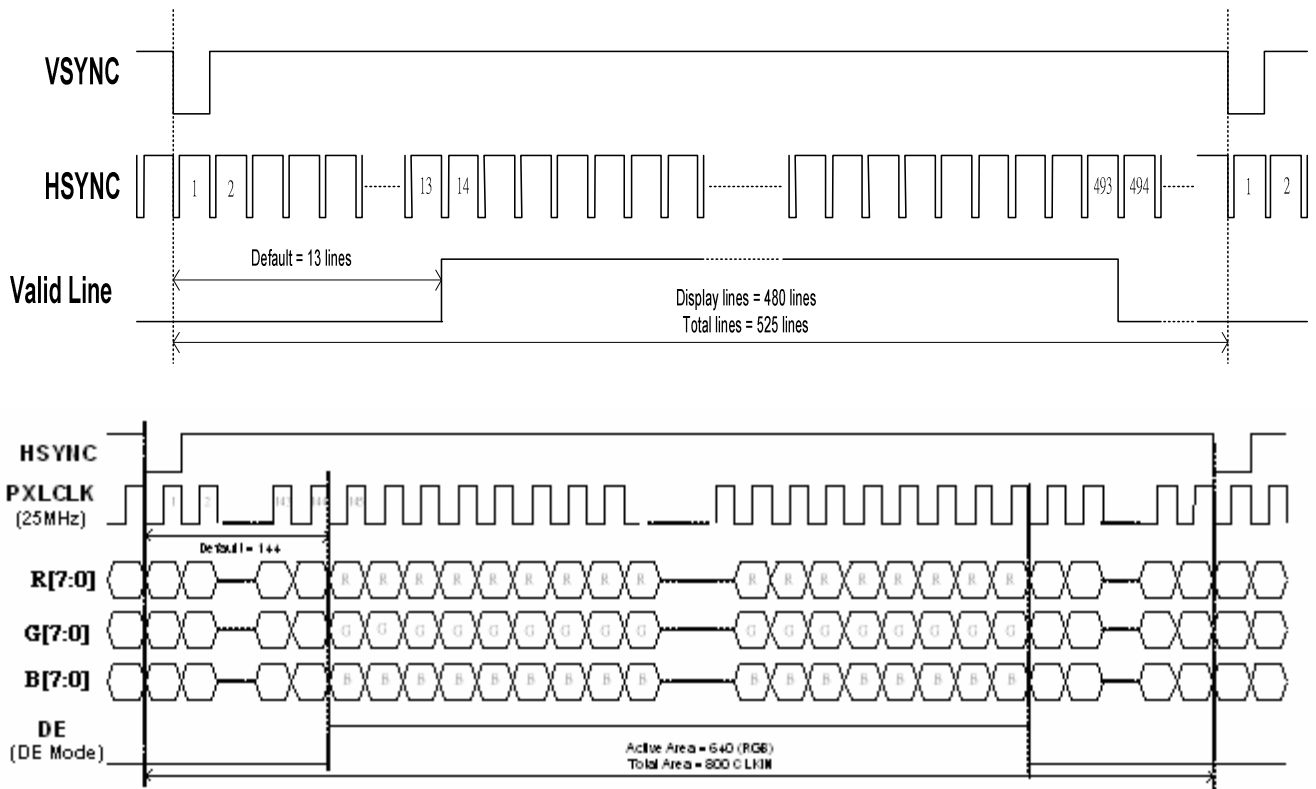

Fig. 3-4 24 bit RGB mode for 640 x (RGB) x 480

4. Optical Specification

| Item | Symbol | Condition | Values | | | Unit | Remark |
|--------------------------|------------|---------------------------------|--------|------|------|-------------------|------------------|
| | | | Min. | Typ. | Max. | | |
| Viewing angle (CR≥10) | θ_L | $\Phi=180^\circ$ (9 o'clock) | 60 | 70 | - | degree | Note 1 |
| | θ_R | $\Phi=0^\circ$ (3 o'clock) | 60 | 70 | - | | |
| | θ_T | $\Phi=90^\circ$ (12 o'clock) | 40 | 50 | - | | |
| | θ_B | $\Phi=270^\circ$ (6 o'clock) | 60 | 70 | - | | |
| Response time | T_{ON} | Normal $\theta=\Phi=0^\circ$ | - | 10 | 20 | msec | Note 3 |
| | T_{OFF} | | - | 15 | 30 | msec | Note 3 |
| Contrast ratio | CR | | 400 | 500 | - | - | Note 4 |
| Color chromaticity | W_X | | 0.26 | 0.31 | 0.36 | - | Note 2 Note 5 |
| | W_Y | | 0.28 | 0.33 | 0.38 | - | Note 6 |
| Luminance | L | | 200 | 250 | - | cd/m ² | Note 6 |
| Luminance uniformity | Y_U | | 70 | 75 | - | % | Note 6,7 |

Test Conditions:

1. $DV_{DD}=3.3V$, $I_L=60mA$, the ambient temperature is $25^\circ C$.
2. The test systems refer to Note 2.

Note 1: Definition of viewing angle range

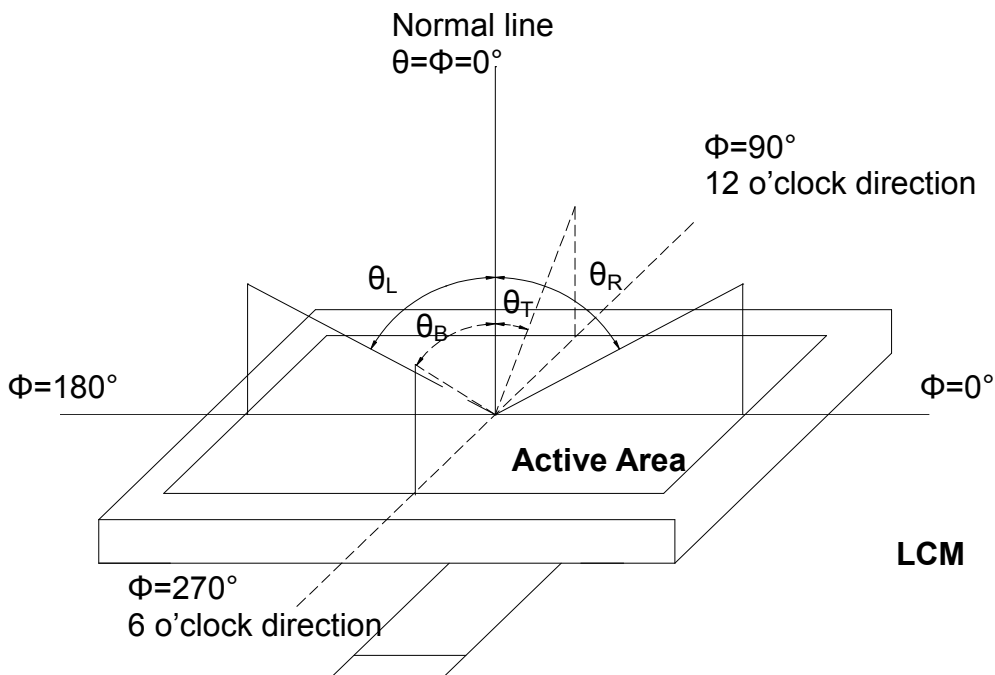

Fig. 4-1 Definition of viewing angle

Note 2: Definition of optical measurement system.

The optical characteristics should be measured in dark room. The optical properties are measured at the center point of the LCD screen. (Response time is measured by Photo detector TOPCON BM-7, other items are measured by BM-5A/Field of view: 1° /Height: 500mm.)

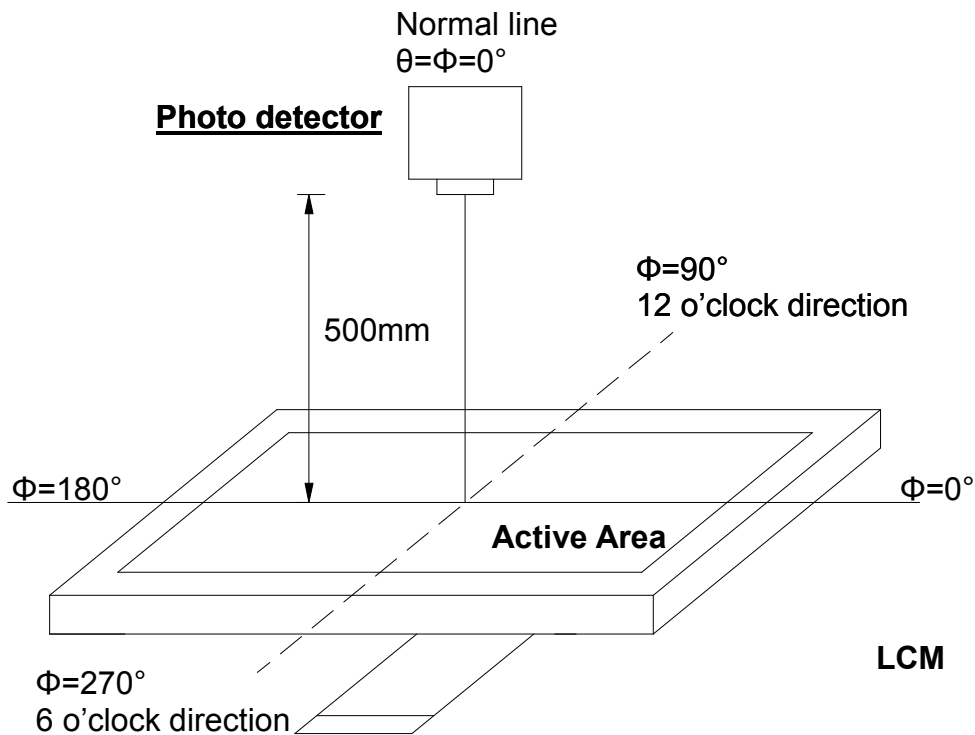

Fig. 4-2 Optical measurement system setup

Note 3: Definition of Response time

The response time is defined as the LCD optical switching time interval between "White" state and "Black" state. Rise time (T_{ON}) is the time between photo detector output intensity changed from 90% to 10%. And fall time (T_{OFF}) is the time between photo detector output intensity changed from 10% to 90%.

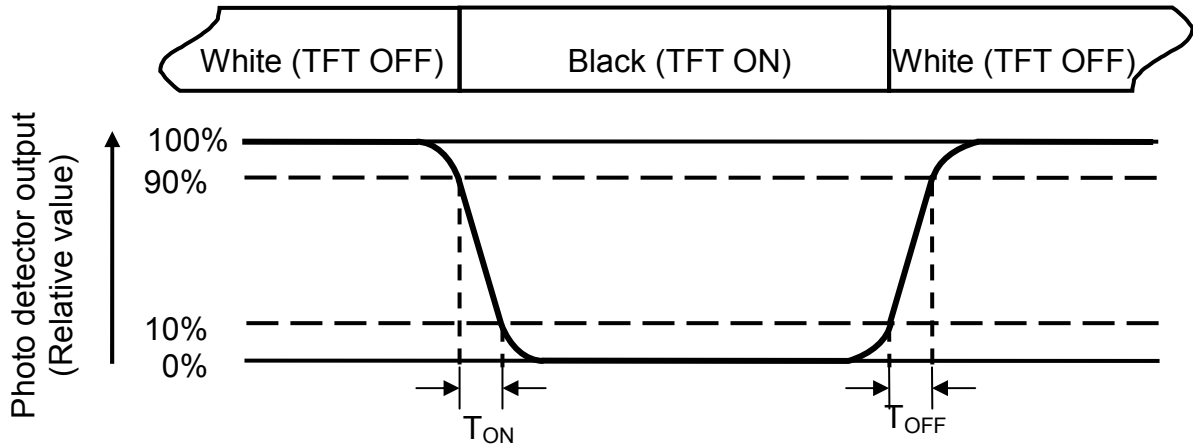

Fig. 4-3 Definition of response time

Note 4: Definition of contrast ratio

$$\text{Contrast ratio (CR)} = \frac{\text{Luminance measured when LCD on the "White" state}}{\text{Luminance measured when LCD on the "Black" state}}$$

Note 5: Definition of color chromaticity (CIE1931)

Color coordinates measured at center point of LCD.

Note 6: All input terminals LCD panel must be ground while measuring the center area of the panel. The LED driving condition is $I_L=60\text{mA}$,

Note 7: Definition of Luminance Uniformity

Active area is divided into 9 measuring areas (Refer to Fig. 4-4).Every measuring point is placed at the center of each measuring area.

$$\text{Luminance Uniformity (Yu)} = \frac{B_{min}}{B_{max}}$$

L-----Active area length W----- Active area width

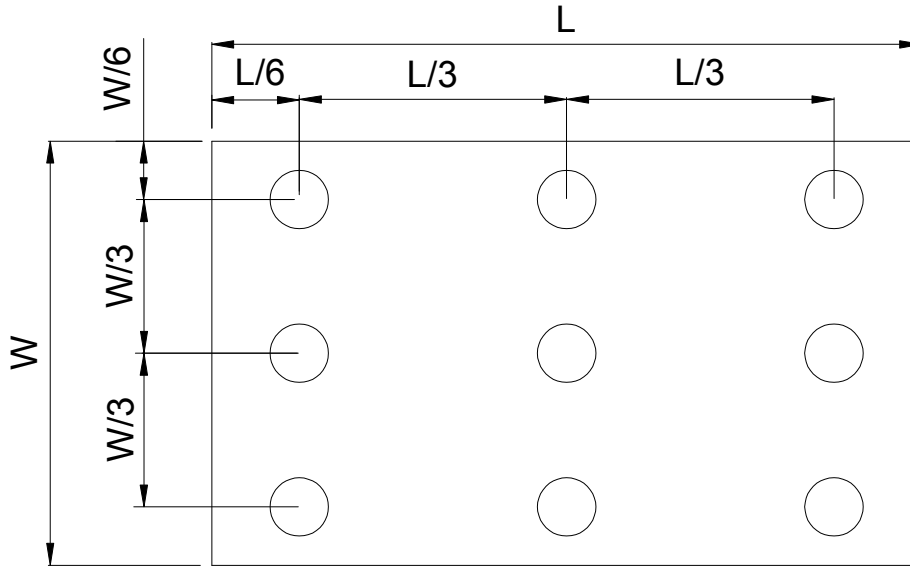

Fig. 4-4 Definition of measuring points

B_{max} : The measured maximum luminance of all measurement position.

B_{min} : The measured minimum luminance of all measurement position.

5. Reliability Test

(Note3)

| Item | Test Conditions | Remark |
|--|---|-----------|
| High Temperature Storage | Ta = 80°C 240 hrs | Note 1, 4 |
| Low Temperature Storage | Ta = -30°C 240hrs | Note 1, 4 |
| High Temperature Operation | Ts = 70°C 240hrs | Note 2, 4 |
| Low Temperature Operation | Ta = -20°C 240hrs | Note 1, 4 |
| Operate at High Temperature and Humidity | +40°C, 90%RH 240 hrs | Note 4 |
| Thermal Shock | -20°C/30 min ~ +70°C/30 min for a total 100 cycles, Start with cold temperature and end with high temperature | Note 4 |
| Vibration Test | Frequency range:10~55Hz Stroke:1.5mm Sweep:10Hz~55Hz~10Hz 2 hours for each direction of X. Y. Z. (6 hours for total) | |
| Mechanical Shock | 100G 6ms,±X, ±Y, ±Z 3 times for each direction | |
| Package Vibration Test | Random Vibration : 0.015G*G/Hz from 5-200HZ, -6dB/Octave from 200-500HZ 2 hours for each direction of X. Y. Z. (6 hours for total) | |
| Package Drop Test | Height:60 cm 1 corner, 3 edges, 6 surfaces | |
| Electro Static Discharge | ± 2KV, Human Body Mode, 100pF/1500Ω | |

Note 1: Ta is the ambient temperature of samples.

Note 2: Ts is the temperature of panel's surface.

Note 3: In the standard condition, there shall be no practical problem that may affect the display function. After the reliability test, the product only guarantees operation, but doesn't guarantee all the cosmetic specification.

Note 4: Before cosmetic and function tests , the product must have enough recovery time, at least 2 hours at room temperature.

6. General Precautions

6.1. Safety

Liquid crystal is poisonous. Do not put it in your mouth. If liquid crystal touches your skin or clothes, wash it off immediately by using soap and water.

6.2. Handling

1. The LCD panel is plate glass. Do not subject the panel to mechanical shock or to excessive force on its surface.
2. The polarizer attached to the display is easily damaged. Please handle it carefully to avoid scratch or other damages.
3. To avoid contamination on the display surface, do not touch the module surface with bare hands.
4. Keep a space so that the LCD panels do not touch other components.
5. Put cover board such as acrylic board on the surface of LCD panel to protect panel from damages.
6. Transparent electrodes may be disconnected if you use the LCD panel under environmental conditions where the condensation of dew occurs.
7. Do not leave module in direct sunlight to avoid malfunction of the ICs.

6.3. Static Electricity

1. Be sure to ground module before turning on power or operating module.
2. Do not apply voltage which exceeds the absolute maximum rating value.

6.4. Storage

1. Store the module in a dark room where must keep at $25\pm 10^{\circ}\text{C}$ and 65%RH or less.
2. Do not store the module in surroundings containing organic solvent or corrosive gas.
3. Store the module in an anti-electrostatic container or bag.

6.5. Cleaning

1. Do not wipe the polarizer with dry cloth. It might cause scratch.
2. Only use a soft sloth with IPA to wipe the polarizer, other chemicals might permanent damage to the polarizer.

7. Mechanical Drawing

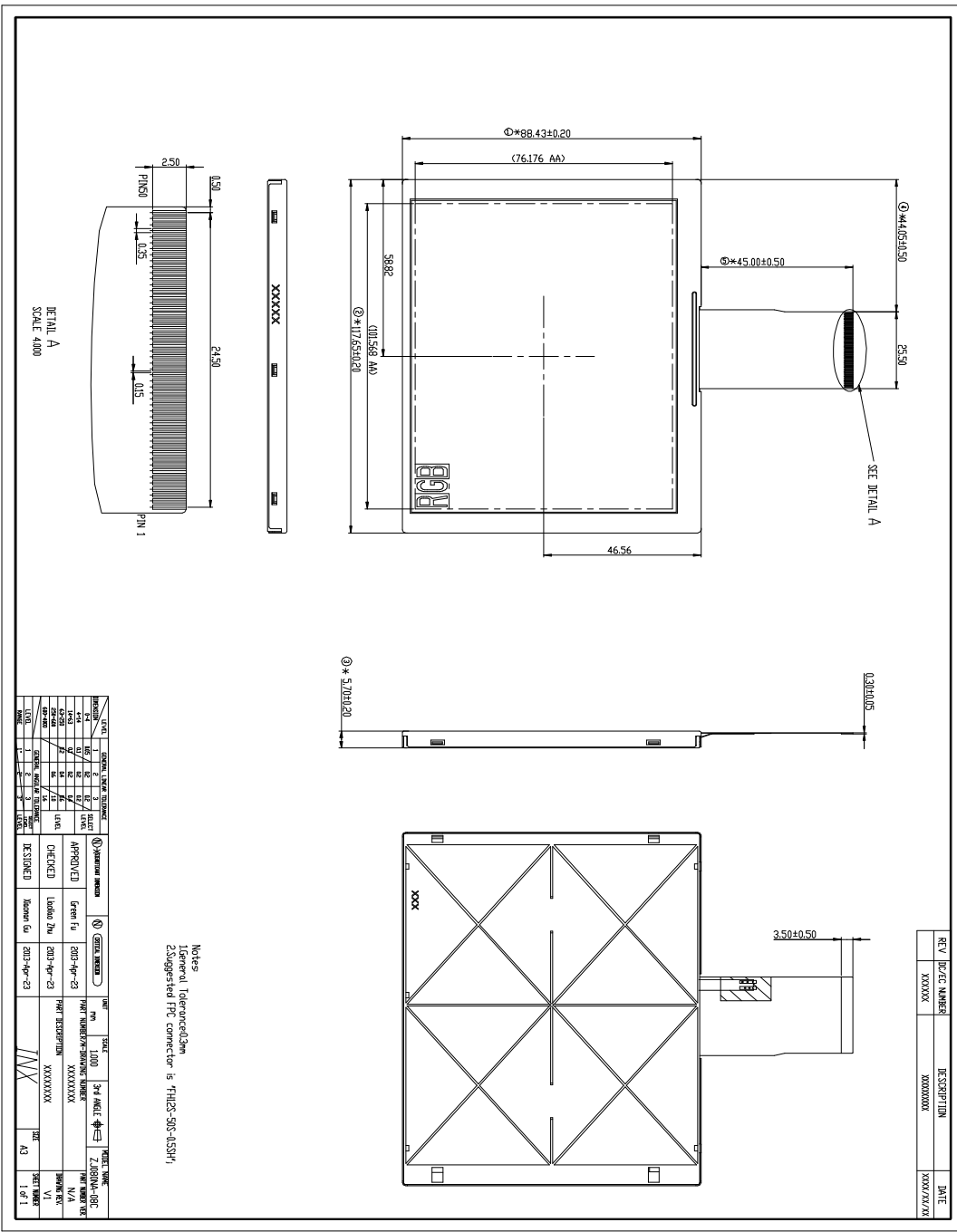

| REV | DEC NUMBER | DESCRIPTION | DATE |
|--------|------------|-------------|------------|
| XXXXXX | XXXXXX | XXXXXX | XXXX/XX/XX |

Notes
 1. General Tolerance: 0.2mm
 2. Suggested FPC connector is FH125-30S-03SH1

| NO. | REV. | DATE | BY | CHKD. | APPV. | DESCRIPTION |
|-----|------|------------|--------|--------|--------|-------------|
| 1 | 1 | 2017-04-23 | XXXXXX | XXXXXX | XXXXXX | XXXXXX |

| NO. | REV. | DATE | BY | CHKD. | APPV. | DESCRIPTION |
|-----|------|------------|--------|--------|--------|-------------|
| 1 | 1 | 2017-04-23 | XXXXXX | XXXXXX | XXXXXX | XXXXXX |

8. Package Drawing

8.1. Packaging Material Table

| No. | Item | Model (Material) | Dimensions(mm) | Unit Weight (kg) | Quantity | Remark |
|-----|------------------|--------------------|----------------------|------------------|----------|--------|
| 1 | LCM Module | ZJ050NA-08C | 117.65 × 88.43 × 5.7 | TBD | 60pcs | |
| 2 | Partition | B Corrugated paper | 512 × 349 × 226 | 1.050 | 1set | |
| 3 | Corrugated Bar | B Corrugated paper | 349 × 198 × 49 | 0.098 | 2set | |
| 4 | Corrugated Board | B Corrugated paper | 512 × 349 | 0.040 | 8pcs | |
| 5 | Dust-Proof Bag | PE | 700 × 530 | 0.060 | 1pcs | |
| 6 | A/S Bag | PE | 180 × 133 × 0.2 | 0.001 | 60pcs | |
| 7 | Carton | Corrugated paper | 530 × 355 × 255 | 0.82 | 1pcs | |
| 8 | Total Weight | TBD kg ± 5% | | | | |

8.2. Packaging Quantity

| |
|--|
| Total LCM quantity in Carton: no. of Partition 4 Rows x quantity per Row 15= 60 |
|--|