

---

---

## 1- and 2-Channel Jitter Attenuators with up to 20 Outputs Product Brief

---

---

### Features

#### Highlights

- One (ZL30273) or two (ZL30274) independent clock channels
- Any-to-any frequency conversion per channel
- Inputs: up to 8, differential or single-ended
- Outputs: up to 10 differential, up to 20 CMOS
- Output jitter 100 fs<sub>RMS</sub> typical for 156.25 MHz 12 kHz to 20 MHz
- Core power consumption <0.9W

#### Input Clocks

- Accepts up to 6 (ZL30273) or 8 (ZL30274) differential or CMOS inputs
- Any input frequency from 1 kHz to 1250 MHz
- Per-input activity and frequency monitoring
- Automatic or manual reference switching
- Revertive or nonrevertive switching
- Any input can be a 0.5 Hz to 8 kHz Sync input for Ref-Sync frequency/phase/time locking
- Input phase measurement, 1 ps resolution
- Per-input phase adjustment, 1 ps resolution

#### DPLLs

- One (ZL30273) or two (ZL30274) DPLLs
- Hitless reference switching
- Per-DPLL phase adjustment, 1 ps resolution
- Programmable bandwidth, tracking range, phase-slope limiting, and other advanced features
- Locking to gapped-clock input signals

#### Output Clocks

- Any frequency 0.5 Hz to 750 MHz
- Each OUP/N pair can be LVDS, LVPECL, 2xCMOS, Low-V<sub>CM</sub>, or programmable differential
- In 2xCMOS mode, the P and N pins can be different frequencies (e.g. 125 MHz and 25 MHz)
- VDD per output pair, CMOS voltages 1.8V to 3.3V
- Per-synth phase adjustment, 1 ps resolution
- Per-output duty cycle adjustment
- Precise output alignment circuitry and per-output phase adjustment
- Per-output enable/disable and glitchless start/stop (stop high or low)

#### Local Oscillator

- Operates from a single oscillator 9.72 MHz to 400 MHz

#### General Features

- Automatic self-configuration at power-up from internal Flash memory, 7 configurations
- Input-to-output alignment <100 ps
- Numerically controlled oscillator behavior in each DPLL and each synthesizer
- Easy-to-configure design requires no external VCXO or loop filter components
- 5 GPIO pins with many possible behaviors, each REF can be GPI, each OUT can be GPO
- SPI or I<sup>2</sup>C processor Interface
- 1.8V and 3.3V core VDD voltages
- Easy-to-use evaluation/programming software

#### Applications

- Frequency conversion, jitter attenuation and frequency synthesis in a wide variety of equipment types

# ZL30273 - ZL30274

## 1.0 BLOCK DIAGRAM

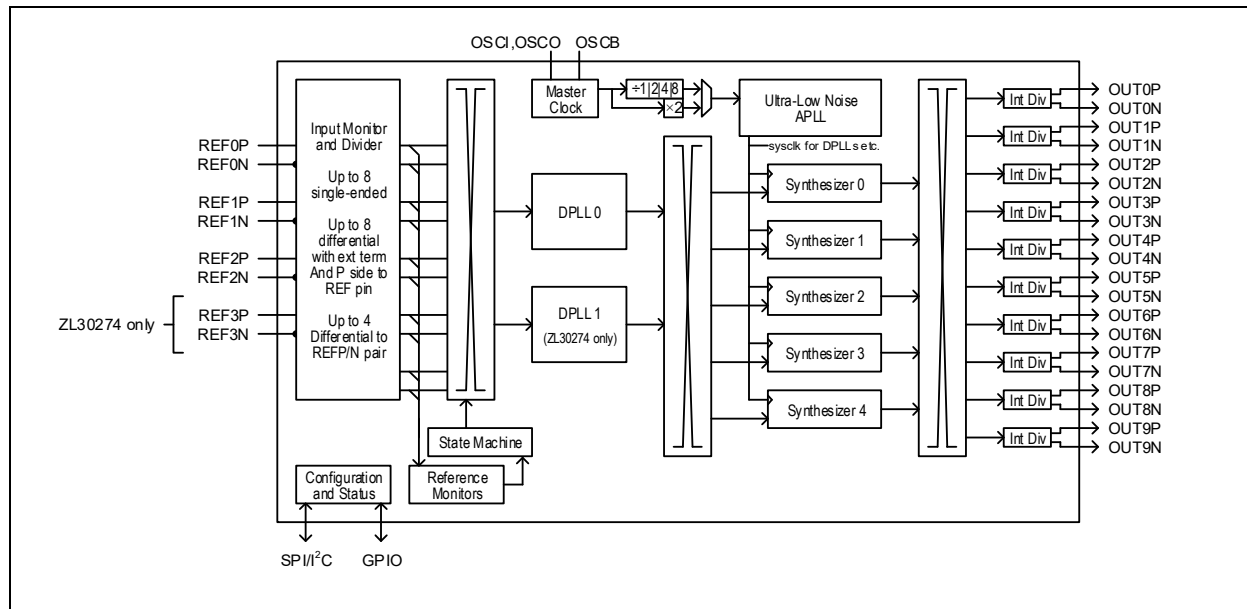

FIGURE 1-1: Functional Block Diagram.

## 2.0 DETAILED FEATURES

### 2.1 General

- One (ZL30273) or two (ZL30274) independent clock channels
- Operates from a single crystal resonator or clock oscillator
  - $\geq 48$  MHz for lowest jitter
  - 9.72 MHz to 400 MHz total frequency range
- Configurable via SPI or I<sup>2</sup>C interface
- Internal nonvolatile memory
  - Factory-configurable power-on configuration
  - Multiple time writeable/re-writeable
- Default settings can be overridden using SPI/I<sup>2</sup>C

### 2.2 Input Block Features

- 6 (ZL30273) or 8 (ZL30274) input reference pins; each can accept a CMOS signal or the POS side of a differential pair; or two can be paired to accept both sides of a differential pair
- Any input can be a SYNC signal (0.5 Hz to 8 kHz) for Ref-Sync frequency/phase/time locking
- Input clocks can be any frequency from 1 kHz up to 1250 MHz (300 MHz max for CMOS inputs)
- Inputs constantly monitored by programmable frequency and single-cycle monitors
- Single-cycle monitor can quickly disqualify a reference when measured period is incorrect
- Frequency measurement and monitoring (coarse, fine, and frequency-step monitors)
- Optional input clock invalidation on GPIO or GPI assertion to react to LOS signals from PHYs
- Input phase measurement, 1 ps resolution
- Per-input phase adjustment, 1 ps resolution
- Each REF pin can be a GPI (general-purpose input)

## 2.3 DPLL Features

- One (ZL30273) or two (ZL30274) DPLLs
- State machine automatically transitions among freerun, tracking, and holdover states
- Revertive or nonrevertive reference selection algorithm
- Programmable bandwidth from 14 Hz to 403 Hz
- Programmable phase-slope limiting (PSL)
- Programmable tracking range (i.e. hold-in range)
- Truly hitless reference switching
- Per-DPLL phase adjustment, 1 ps resolution
- High-resolution frequency and phase measurement (4e-15 and 1 ps)
- Fast detection of input clock failure and transition to holdover mode

## 2.4 Synthesizer Features

- Five next-generation low-jitter, low-power, any-frequency synthesizers
- A total of five output frequency families
- Any-to-any frequency conversion with 0 ppm error
- Easy-to-configure, completely encapsulated design requires no external VCXO or loop filter components
- Jitter suitable for OC-192, STM-64, and 1G, 10G, 40G, 100G, and 400G Ethernet jitter requirements

## 2.5 Output Clock Features

- Up to 20 single-ended outputs, up to 10 differential outputs, from any synthesizer
- Each output can be one differential output or two CMOS outputs
- Output clocks can be any frequency from 0.5 Hz to 750 MHz (250 MHz max for CMOS)
- Output jitter 100 fs<sub>RMS</sub> typical for 156.25 MHz and many other frequencies (12 kHz to 20 MHz)
- In CMOS mode, the OUTxN frequency can be an integer divisor of the OUTxP frequency (Example 1: OUT3P 125 MHz, OUT3N 25 MHz. Example 2: OUT2P 25 MHz, OUT2N 1 Hz)
- Outputs directly interface (DC-coupled) with LVDS, LVPECL, HCSL, and CMOS components
- Supported telecom frequencies include PDH, SDH, Synchronous Ethernet, OTN
- Can produce clock frequencies for microprocessors, ASICs, FPGAs, and other components
- Can produce PCIe Gen 1 to 5 clocks
- Sophisticated output-to-output phase alignment
- Per-synthesizer phase adjustment, 1 ps resolution
- Per-output phase adjustment to accommodate trace delays or compensate for system routing paths
- Per-output duty cycle/pulse width configuration
- Per-output enable/disable
- Per-output glitchless start/stop (stop high or low)
- Each OUT pin can be a GPO (general-purpose output)

## 2.6 Local Oscillator

- Operates from a single oscillator (jitter reference for the device). Acceptable frequencies: 9.72 MHz to 400 MHz. Best jitter:  $\geq 48$  MHz.

## 2.7 General Features

- Automatic self-configuration at power-up from internal Flash memory
- Input-to-output alignment <200 ps with external feedback
- Generates output SYNC signals: 1PPS (IEEE 1588), 2 kHz or 8 kHz (SONET/SDH), or other frequency
- JESD204B clocking: clock and SYSREF signal generation with skew adjustment
- Numerically controlled oscillator (NCO) behavior allows system software to steer DPLL frequency or synthesizer frequency with resolution better than 0.005 ppt

# ZL30273 - ZL30274

- Spread-spectrum modulation available in each synthesizer (PCIe compliant)
- Five general-purpose I/O pins each with many possible status and control options
- SPI or I<sup>2</sup>C serial microprocessor interface

## 2.8 Evaluation Software

- Simple, intuitive Windows-based graphical user interface
- Supports all device features and register fields
- Makes lab evaluation of the device quick and easy
- Generates configuration scripts
- Works with or without an evaluation board

## 3.0 PIN DIAGRAM

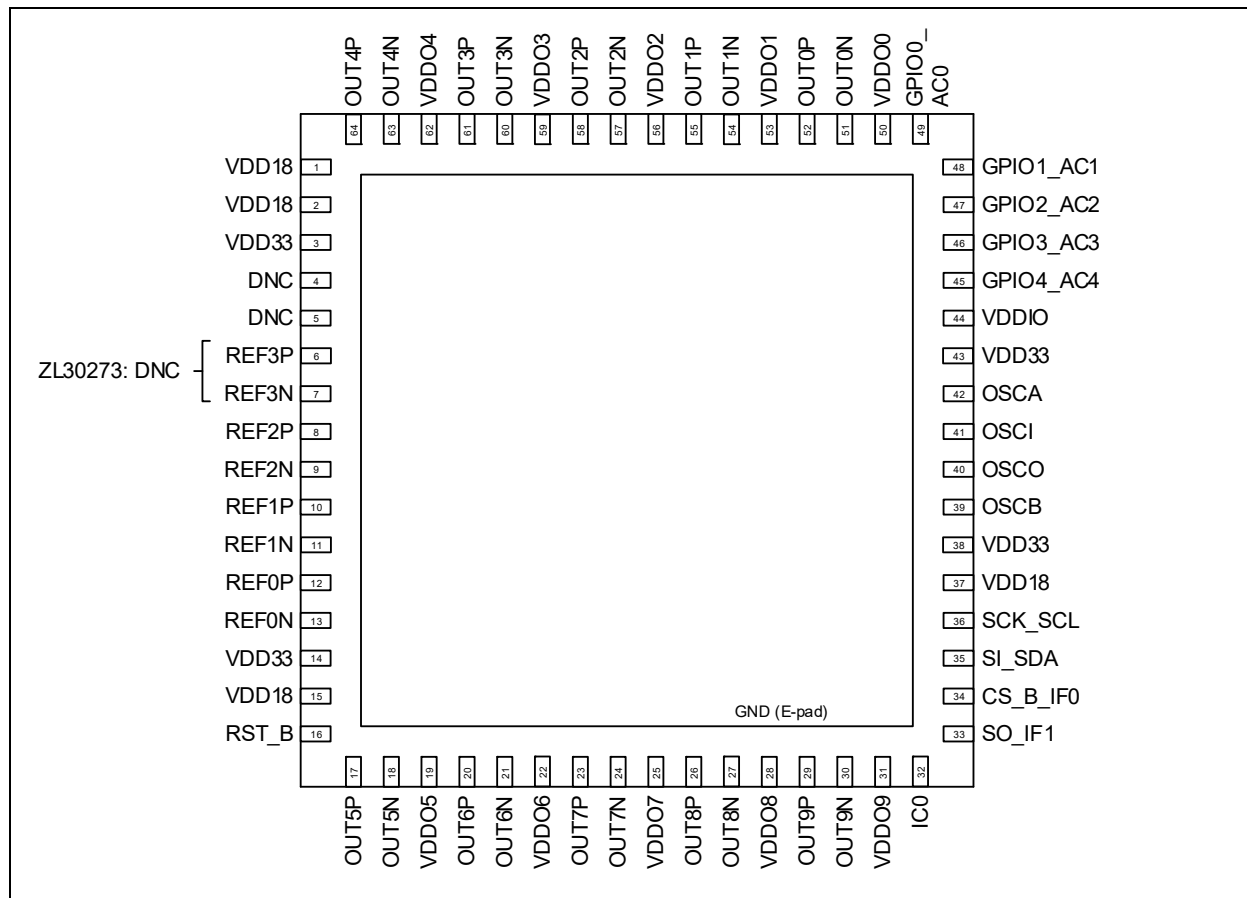

**FIGURE 1:** 64-Lead 9 mm x 9 mm VQFN (0.5 mm pitch) for ZL30273 and ZL30274.

---

---

**Note the following details of the code protection feature on Microchip products:**

- Microchip products meet the specifications contained in their particular Microchip Data Sheet.
- Microchip believes that its family of products is secure when used in the intended manner, within operating specifications, and under normal conditions.
- Microchip values and aggressively protects its intellectual property rights. Attempts to breach the code protection features of Microchip product is strictly prohibited and may violate the Digital Millennium Copyright Act.
- Neither Microchip nor any other semiconductor manufacturer can guarantee the security of its code. Code protection does not mean that we are guaranteeing the product is “unbreakable”. Code protection is constantly evolving. Microchip is committed to continuously improving the code protection features of our products.

---

This publication and the information herein may be used only with Microchip products, including to design, test, and integrate Microchip products with your application. Use of this information in any other manner violates these terms. Information regarding device applications is provided only for your convenience and may be superseded by updates. It is your responsibility to ensure that your application meets with your specifications. Contact your local Microchip sales office for additional support or, obtain additional support at <https://www.microchip.com/en-us/support/design-help/client-support-services>.

THIS INFORMATION IS PROVIDED BY MICROCHIP "AS IS". MICROCHIP MAKES NO REPRESENTATIONS OR WARRANTIES OF ANY KIND WHETHER EXPRESS OR IMPLIED, WRITTEN OR ORAL, STATUTORY OR OTHERWISE, RELATED TO THE INFORMATION INCLUDING BUT NOT LIMITED TO ANY IMPLIED WARRANTIES OF NON-INFRINGEMENT, MERCHANTABILITY, AND FITNESS FOR A PARTICULAR PURPOSE, OR WARRANTIES RELATED TO ITS CONDITION, QUALITY, OR PERFORMANCE.

IN NO EVENT WILL MICROCHIP BE LIABLE FOR ANY INDIRECT, SPECIAL, PUNITIVE, INCIDENTAL, OR CONSEQUENTIAL LOSS, DAMAGE, COST, OR EXPENSE OF ANY KIND WHATSOEVER RELATED TO THE INFORMATION OR ITS USE, HOWEVER CAUSED, EVEN IF MICROCHIP HAS BEEN ADVISED OF THE POSSIBILITY OR THE DAMAGES ARE FORESEEABLE. TO THE FULLEST EXTENT ALLOWED BY LAW, MICROCHIP'S TOTAL LIABILITY ON ALL CLAIMS IN ANY WAY RELATED TO THE INFORMATION OR ITS USE WILL NOT EXCEED THE AMOUNT OF FEES, IF ANY, THAT YOU HAVE PAID DIRECTLY TO MICROCHIP FOR THE INFORMATION.

Use of Microchip devices in life support and/or safety applications is entirely at the buyer's risk, and the buyer agrees to defend, indemnify and hold harmless Microchip from any and all damages, claims, suits, or expenses resulting from such use. No licenses are conveyed, implicitly or otherwise, under any Microchip intellectual property rights unless otherwise stated.

**Trademarks**

The Microchip name and logo, the Microchip logo, Adaptec, AnyRate, AVR, AVR logo, AVR Freaks, BesTime, BitCloud, CryptoMemory, CryptoRF, dsPIC, flexPWR, HELDO, IGLoo, JukeBlox, KeeLoq, Klear, LANCheck, LinkMD, maXStylus, maXTouch, MediaLB, megaAVR, Microsemi, Microsemi logo, MOST, MOST logo, MPLAB, OptoLyzer, PIC, picoPower, PICSTART, PIC32 logo, PolarFire, Prochip Designer, QTouch, SAM-BA, SenGenuity, SpyNIC, SST, SST Logo, SuperFlash, Symmetricom, SyncServer, Tachyon, TimeSource, tinyAVR, UNI/O, Vectron, and XMEGA are registered trademarks of Microchip Technology Incorporated in the U.S.A. and other countries.

AgileSwitch, APT, ClockWorks, The Embedded Control Solutions Company, EtherSynch, Flashtec, Hyper Speed Control, HyperLight Load, IntelliMOS, Libero, motorBench, mTouch, Powermite 3, Precision Edge, ProASIC, ProASIC Plus, ProASIC Plus logo, Quiet-Wire, SmartFusion, SyncWorld, Temux, TimeCesium, TimeHub, TimePictra, TimeProvider, TrueTime, WinPath, and ZL are registered trademarks of Microchip Technology Incorporated in the U.S.A.

Adjacent Key Suppression, AKS, Analog-for-the-Digital Age, Any Capacitor, AnyIn, AnyOut, Augmented Switching, BlueSky, BodyCom, CodeGuard, CryptoAuthentication, CryptoAutomotive, CryptoCompanion, CryptoController, dsPICDEM, dsPICDEM.net, Dynamic Average Matching, DAM, ECAN, Espresso T1S, EtherGREEN, GridTime, IdealBridge, In-Circuit Serial Programming, ICSP, INICnet, Intelligent Paralleling, Inter-Chip Connectivity, JitterBlocker, Knob-on-Display, maxCrypto, maxView, memBrain, Mindi, MiWi, MPASM, MPF, MPLAB Certified logo, MPLIB, MPLINK, MultiTRAK, NetDetach, NVM Express, NVMe, Omniscient Code Generation, PICDEM, PICDEM.net, PICkit, PICtail, PowerSmart, PureSilicon, QMatrix, REAL ICE, Ripple Blocker, RTAX, RTG4, SAM-ICE, Serial Quad I/O, simpleMAP, SimpliPHY, SmartBuffer, SmartHLS, SMART-I.S., storClad, SQI, SuperSwitcher, SuperSwitcher II, Switchtec, SynchroPHY, Total Endurance, TSHARC, USBCheck, VariSense, VectorBlox, VeriPHY, ViewSpan, WiperLock, XpressConnect, and ZENA are trademarks of Microchip Technology Incorporated in the U.S.A. and other countries.

SQTP is a service mark of Microchip Technology Incorporated in the U.S.A.

The Adaptec logo, Frequency on Demand, Silicon Storage Technology, Symmcom, and Trusted Time are registered trademarks of Microchip Technology Inc. in other countries.

GestIC is a registered trademark of Microchip Technology Germany II GmbH & Co. KG, a subsidiary of Microchip Technology Inc., in other countries.

All other trademarks mentioned herein are property of their respective companies.

© 2021, Microchip Technology Incorporated and its subsidiaries. All Rights Reserved.

ISBN: 978-1-5224-9399-0

For information regarding Microchip's Quality Management Systems, please visit [www.microchip.com/quality](http://www.microchip.com/quality).

---

---



# MICROCHIP

## Worldwide Sales and Service

### AMERICAS

**Corporate Office**  
2355 West Chandler Blvd.  
Chandler, AZ 85224-6199  
Tel: 480-792-7200  
Fax: 480-792-7277  
Technical Support:  
<http://www.microchip.com/support>  
Web Address:  
[www.microchip.com](http://www.microchip.com)

**Atlanta**  
Duluth, GA  
Tel: 678-957-9614  
Fax: 678-957-1455

**Austin, TX**  
Tel: 512-257-3370

**Boston**  
Westborough, MA  
Tel: 774-760-0087  
Fax: 774-760-0088

**Chicago**  
Itasca, IL  
Tel: 630-285-0071  
Fax: 630-285-0075

**Dallas**  
Addison, TX  
Tel: 972-818-7423  
Fax: 972-818-2924

**Detroit**  
Novi, MI  
Tel: 248-848-4000

**Houston, TX**  
Tel: 281-894-5983

**Indianapolis**  
Noblesville, IN  
Tel: 317-773-8323  
Fax: 317-773-5453  
Tel: 317-536-2380

**Los Angeles**  
Mission Viejo, CA  
Tel: 949-462-9523  
Fax: 949-462-9608  
Tel: 951-273-7800

**Raleigh, NC**  
Tel: 919-844-7510

**New York, NY**  
Tel: 631-435-6000

**San Jose, CA**  
Tel: 408-735-9110  
Tel: 408-436-4270

**Canada - Toronto**  
Tel: 905-695-1980  
Fax: 905-695-2078

### ASIA/PACIFIC

**Australia - Sydney**  
Tel: 61-2-9868-6733

**China - Beijing**  
Tel: 86-10-8569-7000

**China - Chengdu**  
Tel: 86-28-8665-5511

**China - Chongqing**  
Tel: 86-23-8980-9588

**China - Dongguan**  
Tel: 86-769-8702-9880

**China - Guangzhou**  
Tel: 86-20-8755-8029

**China - Hangzhou**  
Tel: 86-571-8792-8115

**China - Hong Kong SAR**  
Tel: 852-2943-5100

**China - Nanjing**  
Tel: 86-25-8473-2460

**China - Qingdao**  
Tel: 86-532-8502-7355

**China - Shanghai**  
Tel: 86-21-3326-8000

**China - Shenyang**  
Tel: 86-24-2334-2829

**China - Shenzhen**  
Tel: 86-755-8864-2200

**China - Suzhou**  
Tel: 86-186-6233-1526

**China - Wuhan**  
Tel: 86-27-5980-5300

**China - Xian**  
Tel: 86-29-8833-7252

**China - Xiamen**  
Tel: 86-592-2388138

**China - Zhuhai**  
Tel: 86-756-3210040

### ASIA/PACIFIC

**India - Bangalore**  
Tel: 91-80-3090-4444

**India - New Delhi**  
Tel: 91-11-4160-8631

**India - Pune**  
Tel: 91-20-4121-0141

**Japan - Osaka**  
Tel: 81-6-6152-7160

**Japan - Tokyo**  
Tel: 81-3-6880-3770

**Korea - Daegu**  
Tel: 82-53-744-4301

**Korea - Seoul**  
Tel: 82-2-554-7200

**Malaysia - Kuala Lumpur**  
Tel: 60-3-7651-7906

**Malaysia - Penang**  
Tel: 60-4-227-8870

**Philippines - Manila**  
Tel: 63-2-634-9065

**Singapore**  
Tel: 65-6334-8870

**Taiwan - Hsin Chu**  
Tel: 886-3-577-8366

**Taiwan - Kaohsiung**  
Tel: 886-7-213-7830

**Taiwan - Taipei**  
Tel: 886-2-2508-8600

**Thailand - Bangkok**  
Tel: 66-2-694-1351

**Vietnam - Ho Chi Minh**  
Tel: 84-28-5448-2100

### EUROPE

**Austria - Wels**  
Tel: 43-7242-2244-39  
Fax: 43-7242-2244-393

**Denmark - Copenhagen**  
Tel: 45-4485-5910  
Fax: 45-4485-2829

**Finland - Espoo**  
Tel: 358-9-4520-820

**France - Paris**  
Tel: 33-1-69-53-63-20  
Fax: 33-1-69-30-90-79

**Germany - Garching**  
Tel: 49-8931-9700

**Germany - Haan**  
Tel: 49-2129-3766400

**Germany - Heilbronn**  
Tel: 49-7131-72400

**Germany - Karlsruhe**  
Tel: 49-721-625370

**Germany - Munich**  
Tel: 49-89-627-144-0  
Fax: 49-89-627-144-44

**Germany - Rosenheim**  
Tel: 49-8031-354-560

**Israel - Ra'anana**  
Tel: 972-9-744-7705

**Italy - Milan**  
Tel: 39-0331-742611  
Fax: 39-0331-466781

**Italy - Padova**  
Tel: 39-049-7625286

**Netherlands - Drunen**  
Tel: 31-416-690399  
Fax: 31-416-690340

**Norway - Trondheim**  
Tel: 47-7288-4388

**Poland - Warsaw**  
Tel: 48-22-3325737

**Romania - Bucharest**  
Tel: 40-21-407-87-50

**Spain - Madrid**  
Tel: 34-91-708-08-90  
Fax: 34-91-708-08-91

**Sweden - Gothenberg**  
Tel: 46-31-704-60-40

**Sweden - Stockholm**  
Tel: 46-8-5090-4654

**UK - Wokingham**  
Tel: 44-118-921-5800  
Fax: 44-118-921-5820