

June 2004

Ordering Information

ZL60009/TBD TO-46 with lens

-40°C to +85°C

Features

- Data rate up to 200 Mbps
- 1310 - 1550 nm PIN
- TO-46 Assembly
- TIA with AGC
- Single 3.3 V supply
- Low power consumption

Applications

- Sonet OC-3
- SDH STM-1
- ATM 155 Mbps
- FDDI, Ethernet

Description

This optical receiver is a 3.3 V device which contains a PIN photodiode and a low noise transimpedance amplifier assembled in a TO-46 package. It is designed for OC-3/STM-1 operation. Its optical system is designed for single mode fiber as well as for multi mode fiber with a core diameter up to 62.5 μm . Reliability Assurance based on Telcordia GR-468-CORE.

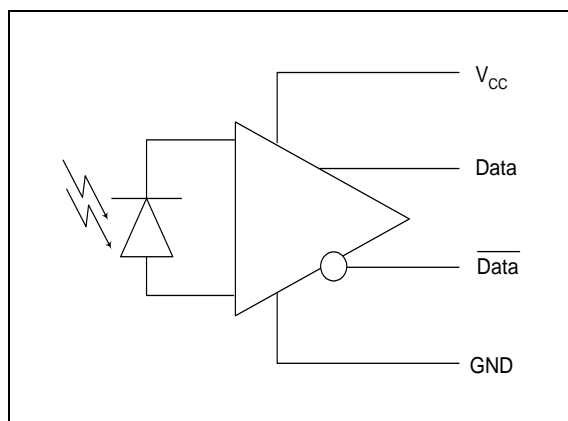
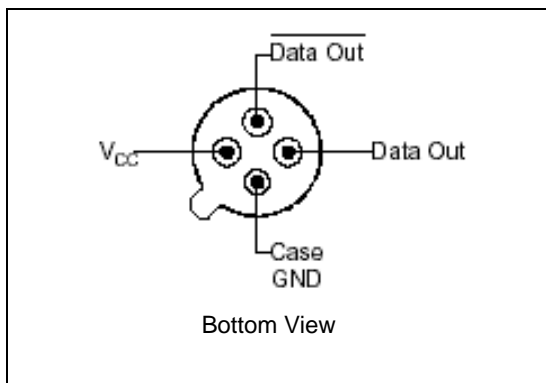
Figure 2 - Functional Schematic

Figure 1 - Pin Diagram

Optical and Electrical Characteristics

Parameter	Symbol	Min.	Typ.	Max.	Unit	Test Condition
Responsivity, differential	R	13	39		kV/W	$\lambda=1310$ nm $R_L = 100 \Omega$, Note 1
Output Voltage amplified, differential	ΔV_O		270		mV _{pp}	$R_L = 100 \Omega$, Note 2
Bandwidth (3 dB _{el})	f_c		140		MHz	$P_f = 10 \mu\text{W}$, $R_L=100 \Omega$
Optical Saturation level, (average)		0	3		dBm	$\lambda=1310$ nm $ER = \infty$, Note 3
Noise-Equivalent Power	NEP		-47		dBm	$\lambda=1310$ nm, Note 4
Dynamic Range			40		dB	
Sensitivity (BER 10^{-9})	S		-37	-36	dBm	$\lambda=1310$ nm $ER = \infty$, Note 3, 5
Output Resistance (single)	R_O		40	100	Ω	
Power Dissipation	P_D		72	115	mW	
Power Supply Current	I_{DD}		22	32	mA	

Operating Conditions: 25°C Case Temperature/3.3 V Supply Voltage/Fiber: Single-mode to multi-mode 62.5/125 μm fiber

Note 1: $P_f = 2\mu\text{W}$ Peak-Peak power at 10 MHz 50% duty cycle

Note 2: $P_f = 100\mu\text{W}$ Peak-Peak average Power at 10 MHz 50% duty cycle

Note 3: Measured at 10^{-9} BER with a $2^{23}-1$ PRBS at 155 Mbps

Note 4: Measured with STM-1 filter on electrical output i.e. 116 MHz

Note 5: Penalty at 10^{-10} BER equals 0.26dB

Absolute Maximum Ratings

Parameter	Symbol	Min.	Max.	Unit
Supply Voltage	V_{CC}	-0.5	4.5	V
Storage Temperature	T_{stg}	-55	125	°C

Recommended Operating Conditions

Parameter	Symbol	Min.	Typ.	Max.	Unit
Supply Voltage	V_{CC}	3	3.3	3.6	V
Output Differential Load, Note 6	R_L	100	1000		Ω
Operating Temperature	T_{op}	-40		85	°C

Note 6: The typical value corresponds to the load prevented by a following limiting amplifier.

Typical Responsivity

	Wavelength	Fiber Core/Cladding Diameter Numerical Aperture		
		10/125 μm , NA=0.11	50/125 μm , NA=0.20	62.5/125 μm , NA=0.275
Differential responsivity	1310 nm	39 kV/W	39 kV/W	39 kV/W
Differential responsivity	1550 nm	47 kV/W	47 kV/W	47 kV/W

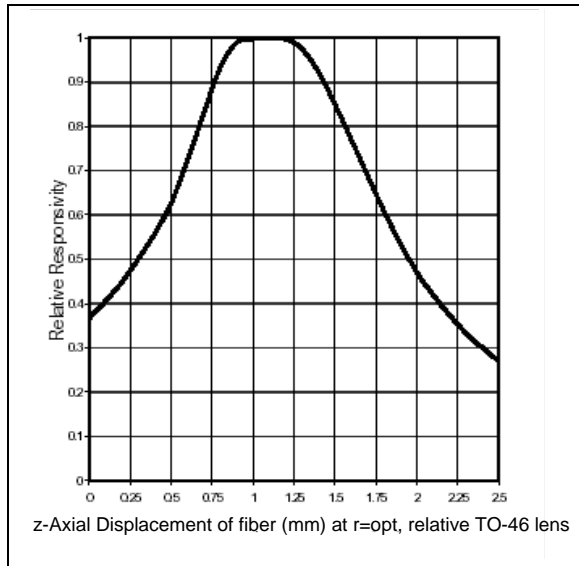

Figure 3 - Typical Responsivity Versus Axial Displacement for a Multimode Fiber

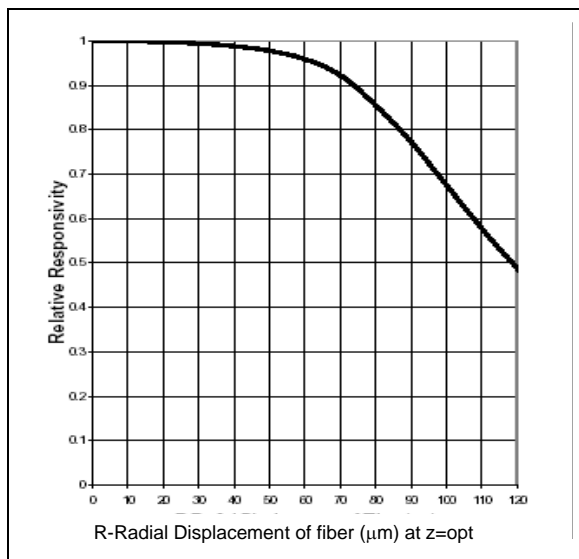

Figure 4 - Typical Responsivity Versus Radial Displacement for a Multimode Fiber

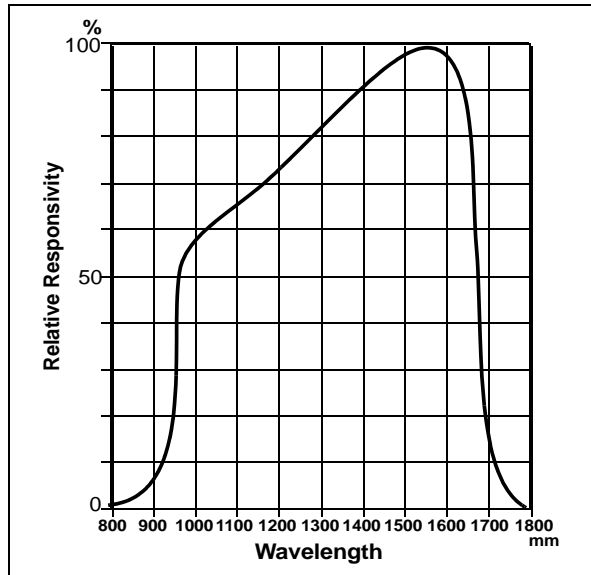

Figure 5 - Responsivity Versus Wavelength of Coupled Input Power

Application Guidelines



ESD Handling

The receiver is sensitive to electrostatic discharges. When handling the device, precaution for ESD sensitive devices should be taken. These precautions include use of ESD protected work area with wrist straps, controlled work benches, floors etc.

Power Supply Filter

Power Supply decoupling capacitors are recommended for optimal performance of the receiver. A filter is recommended to minimise power supply noise. see Figure 7.

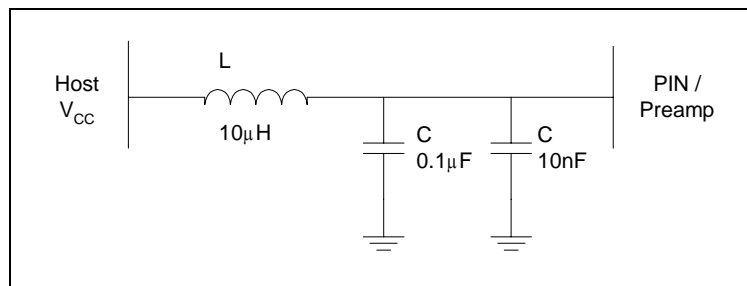

Figure 6 - Recommended Power Supply Filter

Data Outputs

Outputs, Data and $\overline{\text{Data}}$, need to be AC-coupled according to Figure 8. The capacitor determines the low-frequency cut-off for the system.

For improved sensitivity the optional filter capacitor C_F should be chosen to constitute a $0.75 \cdot \text{bit rate BW}$ filter.

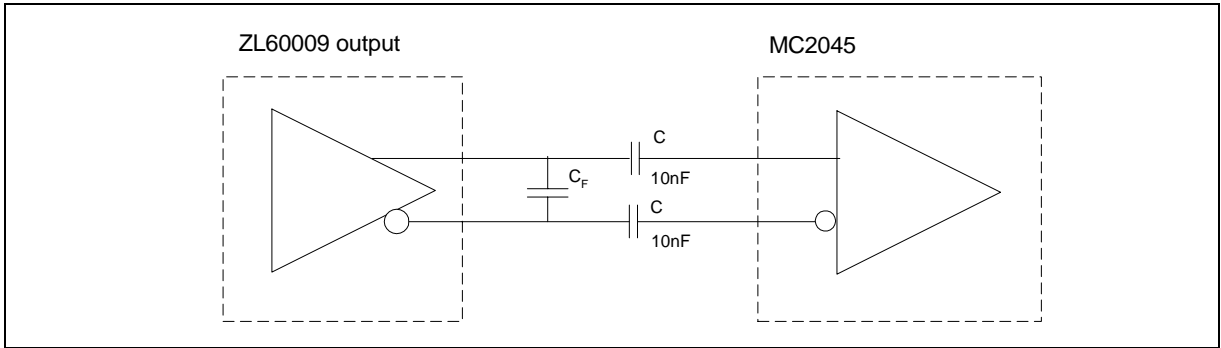
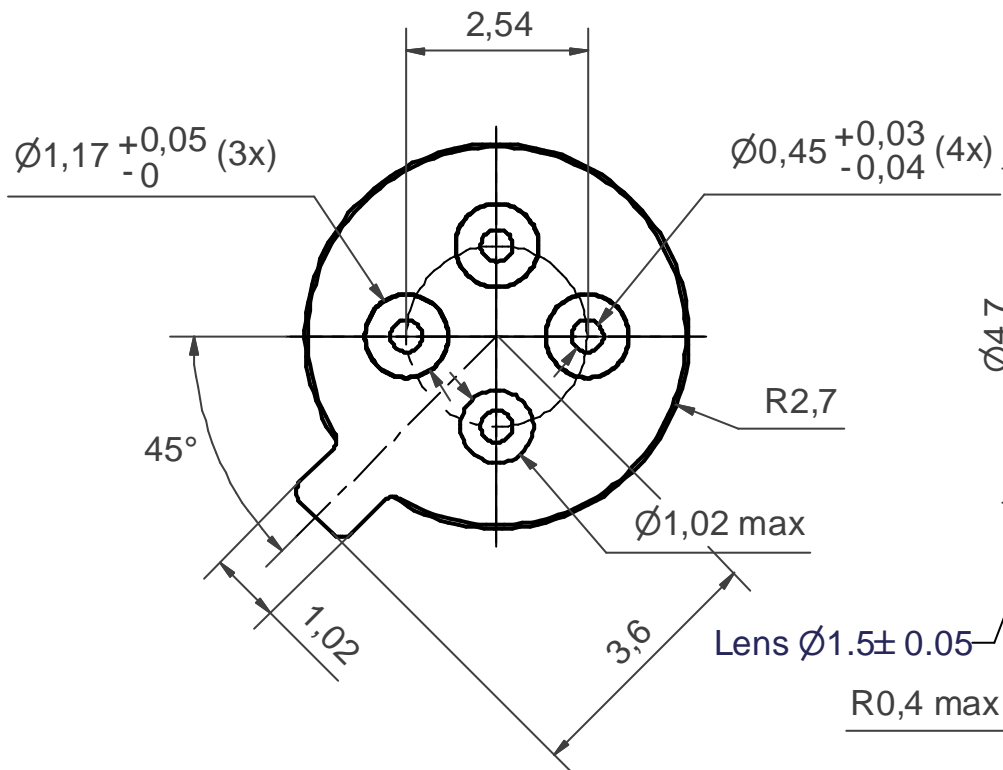
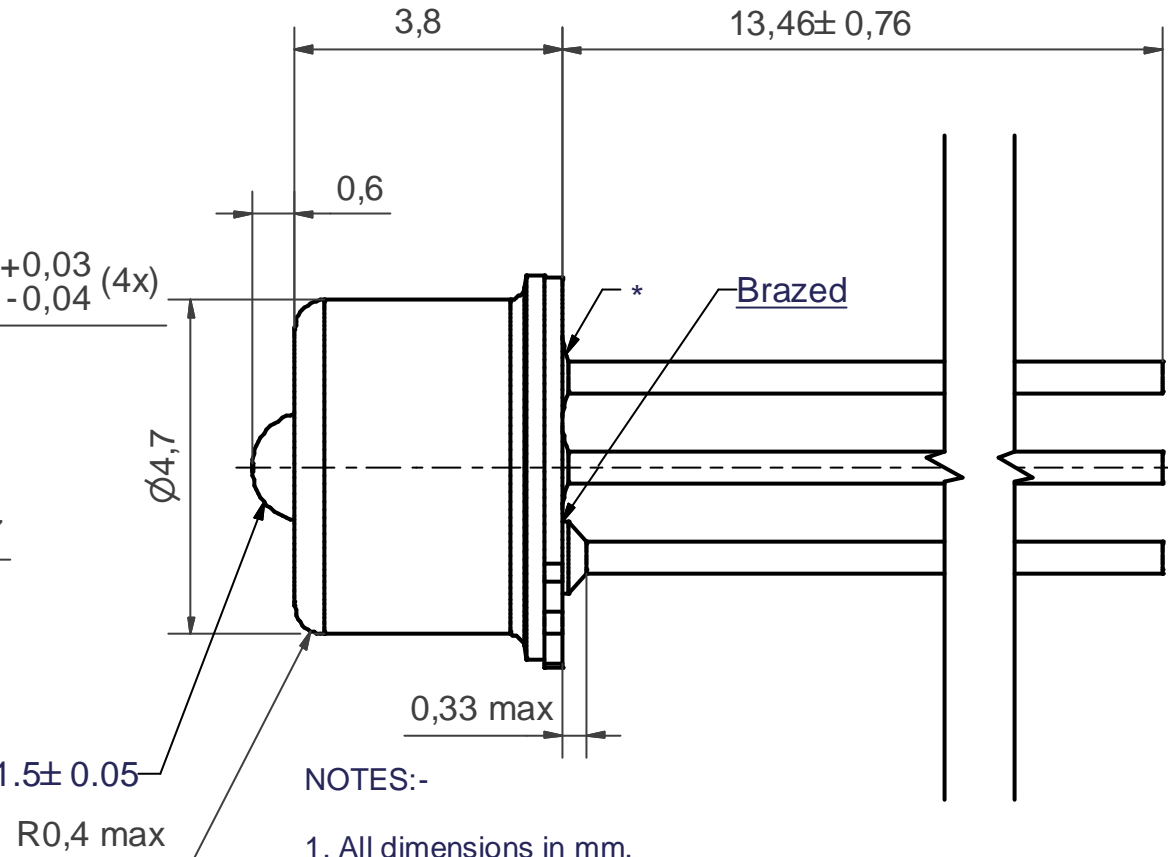

Figure 7 - Required coupling and filter capacitors

BOTTOM VIEW (10 : 1)



SIDE VIEW



NOTES:-

- 1. All dimensions in mm.
- 2. General tol. ISO-2768-mK.
- 3. Coating: Case: Ni 1,5-2,5 μ m.
Header: Ni min 0,5 μ m / Au min 1,5 μ m.

* 0,25 max glass overmould (3x)

© Zarlink Semiconductor 2002. All rights reserved.

ISSUE	1			
ACN	JS004078R1A			
DATE	22-MAR-03			
APPRD.	TD/BE			



	Package code TB
Previous package codes	Drawing type Package drawing, TO-46 with lens
	Title JS004078



**For more information about all Zarlink products
visit our Web Site at
www.zarlink.com**

Information relating to products and services furnished herein by Zarlink Semiconductor Inc. or its subsidiaries (collectively "Zarlink") is believed to be reliable. However, Zarlink assumes no liability for errors that may appear in this publication, or for liability otherwise arising from the application or use of any such information, product or service or for any infringement of patents or other intellectual property rights owned by third parties which may result from such application or use. Neither the supply of such information or purchase of product or service conveys any license, either express or implied, under patents or other intellectual property rights owned by Zarlink or licensed from third parties by Zarlink, whatsoever. Purchasers of products are also hereby notified that the use of product in certain ways or in combination with Zarlink, or non-Zarlink furnished goods or services may infringe patents or other intellectual property rights owned by Zarlink.

This publication is issued to provide information only and (unless agreed by Zarlink in writing) may not be used, applied or reproduced for any purpose nor form part of any order or contract nor to be regarded as a representation relating to the products or services concerned. The products, their specifications, services and other information appearing in this publication are subject to change by Zarlink without notice. No warranty or guarantee express or implied is made regarding the capability, performance or suitability of any product or service. Information concerning possible methods of use is provided as a guide only and does not constitute any guarantee that such methods of use will be satisfactory in a specific piece of equipment. It is the user's responsibility to fully determine the performance and suitability of any equipment using such information and to ensure that any publication or data used is up to date and has not been superseded. Manufacturing does not necessarily include testing of all functions or parameters. These products are not suitable for use in any medical products whose failure to perform may result in significant injury or death to the user. All products and materials are sold and services provided subject to Zarlink's conditions of sale which are available on request.

Purchase of Zarlink's I²C components conveys a licence under the Philips I²C Patent rights to use these components in and I²C System, provided that the system conforms to the I²C Standard Specification as defined by Philips.

Zarlink, ZL and the Zarlink Semiconductor logo are trademarks of Zarlink Semiconductor Inc.

Copyright Zarlink Semiconductor Inc. All Rights Reserved.

TECHNICAL DOCUMENTATION - NOT FOR RESALE
