

**SET-TOP BOX SERIES SINGLE LNB
CONTROLLER AND POWER SUPPLY IC**

Summary

The ZLPM8011 is a power management and control solution for satellite set-top boxes (STBs). Based on an efficient boost converter the ZLPM8011 provides the power supply and all the control signals required by a single port satellite Low Noise Block (LNB). The ZLPM8011 includes an accurate 22kHz tone generator to provide DiSEqC™ control words or continuous tone for band switching control. To provide a reliable DiSEqC 2.0 solution the IC includes a DiSEqC detector with unwanted signal rejection. Controlled by an I²C™ compatible interface or logic inputs and with the minimal external components the ZLPM8011 provides a high performing, efficient cost efficient solution.

Features

- High system efficiency with standby mode
- Efficient boost converter and LDO providing an accurate adjustable power supply for LNBs
- Provides a protected output of up to 550mA
 - Programmable current limit for system flexibility
- Designed for stability with low power LNBs
- Provides standard voltage / tone and DiSEqC control signals and allows for regional variations such as Japan.
 - Internal tone generator for DiSEqC control and traditional band switching
 - Tone maintains shape across all load conditions
- Internal reliable tone detector for DiSEqC 2.0 systems
- Controlled by I²C interface or independent logic control
- Built in multiple diagnostics and protection for IC and LNB protection
- Minimal external components for a simple, reliable and cost effective solution
- **Totally Lead-Free & Fully RoHS Compliant (Notes 1 & 2)**
- **Halogen and Antimony Free. “Green” Device (Note 3)**

Notes: 1. No purposely added lead. Fully EU Directive 2002/95/EC (RoHS) & 2011/65/EU (RoHS 2) compliant.
 2. See <http://www.diodes.com> for more information about Diodes Incorporated's definitions of Halogen- and Antimony-free, "Green" and Lead-free.
 3. Halogen- and Antimony-free "Green" products are defined as those which contain <900ppm bromine, <900ppm chlorine (<1500ppm total Br + Cl) and <1000ppm antimony compounds.

Applications

- Single tuner Satellite Set-top boxes
 - High current LNBs
 - Stability with minimal current LNBs
- Satellite PC Cards
- TV's with integrated satellite tuners
- Hybrid Set-top boxes
- Suitable for Digital and Analog satellite systems

System Diagram

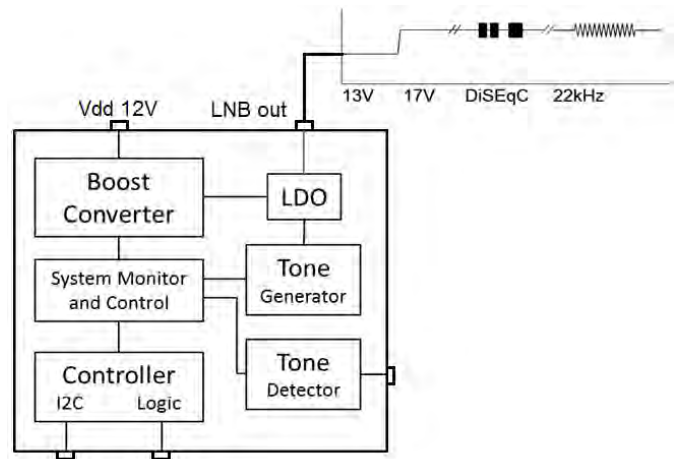

*DiSEqC is a trademark of Eutlesat.
I²C is a trademark of Philips Corp.*

To Request This Datasheet
In Its Entirety Please Email

DBS@diodes.com

IMPORTANT NOTICE

DIODES INCORPORATED MAKES NO WARRANTY OF ANY KIND, EXPRESS OR IMPLIED, WITH REGARDS TO THIS DOCUMENT, INCLUDING, BUT NOT LIMITED TO, THE IMPLIED WARRANTIES OF MERCHANTABILITY AND FITNESS FOR A PARTICULAR PURPOSE (AND THEIR EQUIVALENTS UNDER THE LAWS OF ANY JURISDICTION).

Diodes Incorporated and its subsidiaries reserve the right to make modifications, enhancements, improvements, corrections or other changes without further notice to this document and any product described herein. Diodes Incorporated does not assume any liability arising out of the application or use of this document or any product described herein; neither does Diodes Incorporated convey any license under its patent or trademark rights, nor the rights of others. Any Customer or user of this document or products described herein in such applications shall assume all risks of such use and will agree to hold Diodes Incorporated and all the companies whose products are represented on Diodes Incorporated website, harmless against all damages.

Diodes Incorporated does not warrant or accept any liability whatsoever in respect of any products purchased through unauthorized sales channel. Should Customers purchase or use Diodes Incorporated products for any unintended or unauthorized application, Customers shall indemnify and hold Diodes Incorporated and its representatives harmless against all claims, damages, expenses, and attorney fees arising out of, directly or indirectly, any claim of personal injury or death associated with such unintended or unauthorized application.

Products described herein may be covered by one or more United States, international or foreign patents pending. Product names and markings noted herein may also be covered by one or more United States, international or foreign trademarks.

LIFE SUPPORT

Diodes Incorporated products are specifically not authorized for use as critical components in life support devices or systems without the express written approval of the Chief Executive Officer of Diodes Incorporated. As used herein:

A. Life support devices or systems are devices or systems which:

1. are intended to implant into the body, or
2. support or sustain life and whose failure to perform when properly used in accordance with instructions for use provided in the labeling can be reasonably expected to result in significant injury to the user.

B. A critical component is any component in a life support device or system whose failure to perform can be reasonably expected to cause the failure of the life support device or to affect its safety or effectiveness.

Customers represent that they have all necessary expertise in the safety and regulatory ramifications of their life support devices or systems, and acknowledge and agree that they are solely responsible for all legal, regulatory and safety-related requirements concerning their products and any use of Diodes Incorporated products in such safety-critical, life support devices or systems, notwithstanding any devices- or systems-related information or support that may be provided by Diodes Incorporated. Further, Customers must fully indemnify Diodes Incorporated and its representatives against any damages arising out of the use of Diodes Incorporated products in such safety-critical, life support devices or systems.

Copyright © 2012, Diodes Incorporated

www.diodes.com