



*Crimzon™ ZLR16300*

***Z8 Low Voltage ROM MCUs  
with Infrared Timers***

**Product Specification**

PS021413-1205



This publication is subject to replacement by a later edition. To determine whether a later edition exists, or to request copies of publications, contact:

**ZiLOG Worldwide Headquarters**

532 Race Street  
San Jose, CA 95126-3432  
Telephone: 408.558.8500  
Fax: 408.558.8300  
[www.zilog.com](http://www.zilog.com)

ZiLOG is a registered trademark of ZiLOG Inc. in the United States and in other countries. All other products and/or service names mentioned herein may be trademarks of the companies with which they are associated.

**Document Disclaimer**

©2005 by ZiLOG, Inc. All rights reserved. Information in this publication concerning the devices, applications, or technology described is intended to suggest possible uses and may be superseded. ZiLOG, INC. DOES NOT ASSUME LIABILITY FOR OR PROVIDE A REPRESENTATION OF ACCURACY OF THE INFORMATION, DEVICES, OR TECHNOLOGY DESCRIBED IN THIS DOCUMENT. ZiLOG ALSO DOES NOT ASSUME LIABILITY FOR INTELLECTUAL PROPERTY INFRINGEMENT RELATED IN ANY MANNER TO USE OF INFORMATION, DEVICES, OR TECHNOLOGY DESCRIBED HEREIN OR OTHERWISE. Devices sold by ZiLOG, Inc. are covered by warranty and limitation of liability provisions appearing in the ZiLOG, Inc. Terms and Conditions of Sale. ZiLOG, Inc. makes no warranty of merchantability or fitness for any purpose. Except with the express written approval of ZiLOG, use of information, devices, or technology as critical components of life support systems is not authorized. No licenses are conveyed, implicitly or otherwise, by this document under any intellectual property rights.



## Revision History

Each instance in [Table 1](#) reflects a change to this document from its previous revision. To see more detail, click the appropriate link in the table.

**Table 1. Revision History of this Document**

Date	Revision Level	Description	Page#
December 2004	07	Changed low power consumption and current usage for STOP and HALT modes, removed mask option note, and added characterization data to Table 7.	1, 2, 8
		Removed Preliminary designation	All
January 2005	08	Changed low power consumption value to 5mW. Changed STOP and HALT mode current values to 1.3 $\mu$ A and 0.5mA respectively. Changed V <sub>CC</sub> Low Voltage Protection typical rating to 1.8V.	1, 12
April 2005	09	Clarified Port 1 reserved address status by removing Port 1 in Figure 1 and adding a note in Figure 12. Reference CR5843.	3, 21
June 2005	10	Added 1K and 2K parts.	All
August 2005	11	Added caution to <a href="#">Input/Output Ports on page 12</a> . Updated <a href="#">Ordering Information on page 80</a> .	
September 2005	12	Updated <a href="#">Ordering Information on page 80</a> .	
December 2005	13	Updated the Section Input output port and Clock.	12, 47



# Table of Contents

Revision History . . . . .	iii
Features . . . . .	1
General Description . . . . .	2
Pin Description . . . . .	5
Absolute Maximum Ratings . . . . .	6
Standard Test Conditions . . . . .	7
DC Characteristics . . . . .	8
AC Characteristics . . . . .	10
Pin Functions . . . . .	12
XTAL1 Crystal 1 (Time-Based Input) . . . . .	12
XTAL2 Crystal 2 (Time-Based Output) . . . . .	12
Input/Output Ports . . . . .	12
Functional Description . . . . .	19
Program Memory . . . . .	19
RAM . . . . .	19
Expanded Register File . . . . .	21
Register File . . . . .	24
Stack . . . . .	25
Timers . . . . .	26
Counter/Timer Functional Blocks . . . . .	34
Interrupts . . . . .	44
Clock . . . . .	47
Power Management . . . . .	48
Port Configuration . . . . .	49
Stop-Mode Recovery . . . . .	50
Watchdog Timer Mode . . . . .	56
Low Voltage Detection . . . . .	59
Expanded Register File Control Registers (0D) . . . . .	60
Expanded Register File Control Registers (0F) . . . . .	65
Standard Control Registers . . . . .	69
Package Information . . . . .	75
Ordering Information . . . . .	80
Part Number Description . . . . .	82



# List of Figures

Figure 1. Functional Block Diagram . . . . .	3
Figure 2. Counter/Timers Diagram . . . . .	4
Figure 3. 20-Pin DIP/SOIC/SSOP Pin Configuration . . . . .	5
Figure 4. 28-Pin DIP/SOIC/SSOP Pin Configuration . . . . .	6
Figure 5. Test Load Diagram . . . . .	7
Figure 6. AC Timing Diagram . . . . .	10
Figure 7. Port 0 Configuration . . . . .	14
Figure 8. Port 2 Configuration . . . . .	15
Figure 9. Port 3 Configuration . . . . .	16
Figure 10. Port 3 Counter/Timer Output Configuration . . . . .	18
Figure 11. Program Memory Map . . . . .	20
Figure 12. Expanded Register File Architecture . . . . .	22
Figure 13. Register Pointer . . . . .	23
Figure 14. Register Pointer—Detail . . . . .	25
Figure 15. Glitch Filter Circuitry . . . . .	34
Figure 16. Transmit Mode Flowchart . . . . .	35
Figure 17. 8-Bit Counter/Timer Circuits . . . . .	36
Figure 18. T8_OUT in Single-Pass Mode . . . . .	37
Figure 19. T8_OUT in Modulo-N Mode . . . . .	37
Figure 20. Demodulation Mode Count Capture Flowchart . . . . .	38
Figure 21. Demodulation Mode Flowchart . . . . .	39
Figure 22. 16-Bit Counter/Timer Circuits . . . . .	40
Figure 23. T16_OUT in Single-Pass Mode . . . . .	41
Figure 24. T16_OUT in Modulo-N Mode . . . . .	41
Figure 25. Ping-Pong Mode Diagram . . . . .	43
Figure 26. Output Circuit . . . . .	43
Figure 27. Interrupt Block Diagram . . . . .	45
Figure 28. Oscillator Configuration . . . . .	47
Figure 29. Port Configuration Register (PCON) (Write Only) . . . . .	49
Figure 30. Stop Mode Recovery Register . . . . .	51
Figure 31. SCLK Circuit . . . . .	52
Figure 32. Stop Mode Recovery Source . . . . .	53
Figure 33. Stop Mode Recovery Register 2 ((0F) DH:D2–D4, D6 Write Only) . . . . .	55
Figure 34. Watch-Dog Timer Mode Register (Write Only) . . . . .	56



Figure 35. Resets and WDT	58
Figure 36. TC8 Control Register ((0D) 00H: Read/Write Except Where Noted)	61
Figure 37. T8 and T16 Common Control Functions ((0D) 01H: Read/Write)	62
Figure 38. T16 Control Register ((0D) 02H: Read/Write Except Where Noted)	63
Figure 39. T8/T16 control Register (0D) 03H: Read/Write (Except Where Noted)	64
Figure 40. Voltage Detection Register	65
Figure 41. Port Configuration Register (PCON) ((0F)00H: Write Only)	66
Figure 42. Stop Mode Recovery Register ((0F) 0BH: D6–D0=Write Only, D7=Read Only)	67
Figure 43. Stop Mode Recovery Register 2 ((0F) 0DH: D2–D4, D6 Write Only)	68
Figure 44. Watch-Dog Timer Register ((0F) 0FH: Write Only)	69
Figure 45. Port 2 Mode Register (F6H: Write Only)	69
Figure 46. Port 3 Mode Register (F7H: Write Only)	70
Figure 47. Port 0 Register (F8H: Write Only)	71
Figure 48. Interrupt Priority Register (F9H: Write Only)	72
Figure 49. Interrupt Request Register (FAH: Read/Write)	73
Figure 50. Interrupt Mask Register (FBH: Read/Write)	73
Figure 51. Flag Register (FCH: Read/Write)	74
Figure 52. Register Pointer (FDH: Read/Write)	74
Figure 53. Stack Pointer High (FEH: Read/Write)	75
Figure 54. Stack Pointer Low (FFH: Read/Write)	75
Figure 55. 20-Pin DIP Package Diagram	76
Figure 56. 20-Pin SOIC Package Diagram	76
Figure 57. 20-Pin SSOP Package Diagram	77
Figure 58. 28-Pin SOIC Package Diagram	78
Figure 59. 28-Pin DIP Package Diagram	79
Figure 60. 28-Pin SSOP Package Diagram	80
Figure 61. Part Number Description Example	82



## List of Tables

Table 1.	Revision History of this Document . . . . .	iii
Table 2.	Features . . . . .	1
Table 3.	Power Connections . . . . .	2
Table 4.	20-Pin DIP/SOIC/SSOP Pin Identification . . . . .	5
Table 5.	28-Pin DIP/SOIC/SSOP Pin Identification . . . . .	6
Table 6.	Absolute Maximum Ratings . . . . .	7
Table 7.	Capacitance . . . . .	8
Table 8.	DC Characteristics . . . . .	8
Table 9.	AC Characteristics . . . . .	11
Table 10.	Port 3 Pin Function Summary . . . . .	17
Table 11.	CTR0(0D)00h Counter/Timer8 Control Register . . . . .	27
Table 12.	CTR1(0D)01h T8 and T16 Common Functions . . . . .	29
Table 13.	CTR2(0D)02h: Counter/Timer16 Control Register . . . . .	32
Table 14.	CTR3(0D)03h T8/T16 Control Register . . . . .	33
Table 15.	Interrupt Types, Sources, and Vectors . . . . .	46
Table 16.	IRQ Register . . . . .	46
Table 17.	SMR2(F)0DH:Stop Mode Recovery Register 2* . . . . .	52
Table 18.	Stop Mode Recovery Source . . . . .	54
Table 19.	Watch-Dog Timer Time Select . . . . .	57
Table 20.	ROM Selectable Options . . . . .	59



## Features

Table 2 lists the features of ZiLOG®'s Crimzon™ ZLR16300 family members.

**Table 2. Features**

Device	ROM (KB)	RAM* (Bytes)	I/O Lines	Voltage Range
Crimzon™ ZLR16300	1, 2, 4, 8, 16	237	24, 16	2.0V–3.6V

\* General purpose

- Low power consumption—5mW (typical)
- Three standby modes:
  - STOP—1.3µA (typical)
  - HALT—0.5mA (typical)
  - Low voltage reset
- Special architecture to automate both generation and reception of complex pulses or signals:
  - One programmable 8-bit counter/timer with two capture registers and two load registers
  - One programmable 16-bit counter/timer with one 16-bit capture register pair and one 16-bit load register pair
  - Programmable input glitch filter for pulse reception
- Six priority interrupts
  - Three external
  - Two assigned to counter/timers
  - One low-voltage detection interrupt
- Low voltage detection and high voltage detection flags
- Programmable Watch-Dog Timer (WDT)
- Power-On Reset (POR)
- Two independent comparators with programmable interrupt polarity
- Selectable pull-up transistors on ports 0, 2, 3





- Mask options
  - Port 0: 0–3 pull-ups
  - Port 0: 4–7 pull-ups
  - Port 2: 0–7 pull-ups
  - Port 3: 0–3 pull-ups
  - Watch-Dog Timer at Power On Reset

## General Description

The Crimzon™ ZLR16300 is a ROM-based member of the MCU family of general purpose microcontrollers. With 1KB to 16KB of program memory and 237B of general purpose RAM, ZiLOG®'s CMOS microcontrollers offer fast-executing, efficient use of memory, sophisticated interrupts, input/output bit manipulation capabilities, automated pulse generation/reception, and internal key-scan pull-up transistors.

The Crimzon™ ZLR16300 architecture (Figures 1 and 2) is based on ZiLOG®'s 8-bit microcontroller core with an Expanded Register File allowing access to register-mapped peripherals, input/output (I/O) circuits, and powerful counter/timer circuitry. The Z8® core offers a flexible I/O scheme, an efficient register and address space structure, and a number of ancillary features that are useful in many consumer, automotive, computer peripheral, and battery-operated hand-held applications.

There are three basic address spaces available to support a wide range of configurations: Program Memory, Register File and Expanded Register File. The register file is composed of 256B of RAM. It includes three I/O port registers, 16 control and status registers, and 237 general-purpose registers. The Expanded Register File consists of two additional register groups (F and D).

To unburden the program from coping with such real-time problems as generating complex waveforms or receiving and demodulating complex waveform/pulses, the Crimzon™ ZLR16300 offers a new intelligent counter/timer architecture with 8-bit and 16-bit counter/timers (see Figure 2). Also included are a large number of user-selectable modes and two on-board comparators to process analog signals with separate reference voltages.

Power connections use the conventional descriptions listed in Table 3.

**Table 3. Power Connections**

Connection	Circuit	Device
Power	V <sub>CC</sub>	V <sub>DD</sub>
Ground	GND	V <sub>SS</sub>

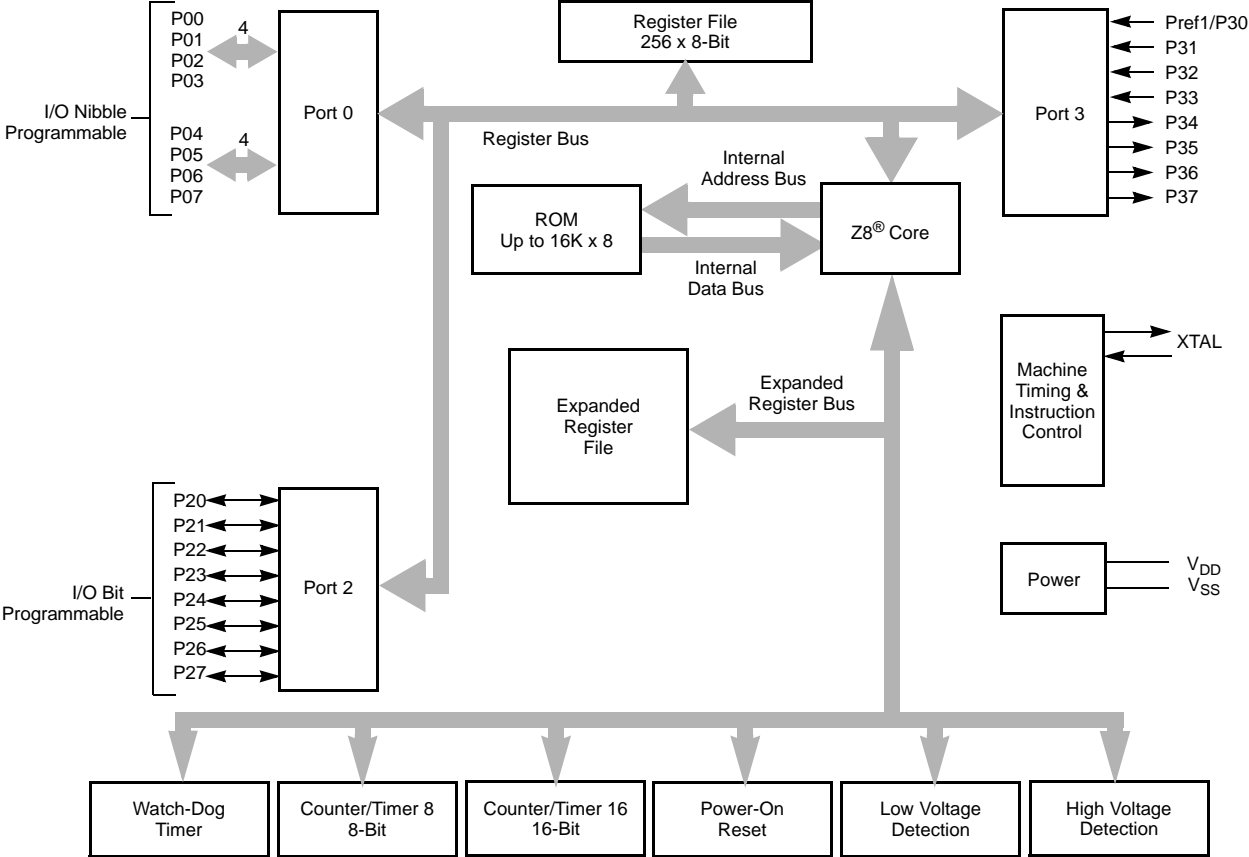

Note: Refer to the specific package for available pins.

Figure 1. Functional Block Diagram

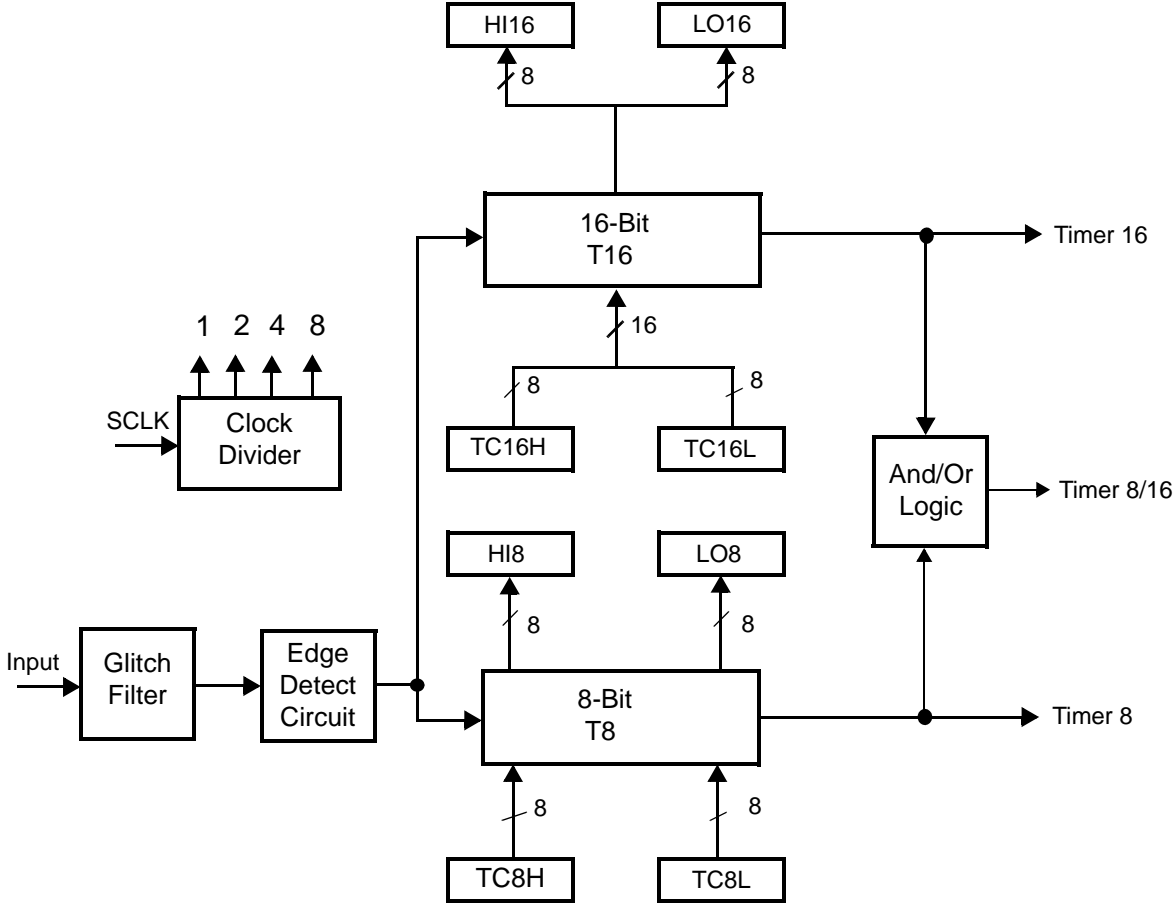
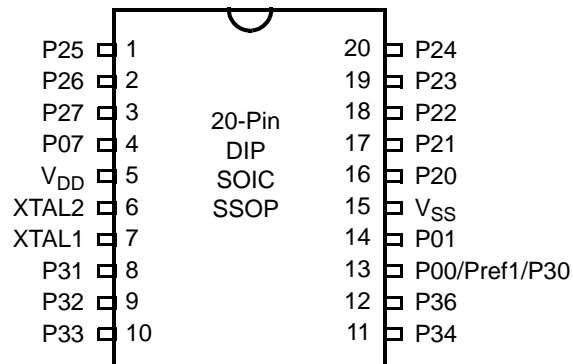

Figure 2. Counter/Timers Diagram

## Pin Description

The pin configuration for the 20-pin DIP/SOIC/SSOP is illustrated in [Figure 3](#) and described in [Table 4](#). The pin configuration for the 28-pin DIP/SOIC/SSOP are depicted in [Figure 4](#) and described in [Table 5](#).



**Figure 3. 20-Pin DIP/SOIC/SSOP Pin Configuration**

**Table 4. 20-Pin DIP/SOIC/SSOP Pin Identification**

Pin #	Symbol	Function	Direction
1–3	P25–P27	Port 2, Bits 5,6,7	Input/Output
4	P07	Port 0, Bit 7	Input/Output
5	V <sub>DD</sub>	Power Supply	
6	XTAL2	Crystal Oscillator Clock	Output
7	XTAL1	Crystal Oscillator Clock	Input
8–10	P31–P33	Port 3, Bits 1,2,3	Input
11,12	P34, P36	Port 3, Bits 4,6	Output
13	P00/Pref1/P30	Port 0, Bit 0/Analog reference input Port 3, Bit 0	Input/Output for P00 Input for Pref1/P30
14	P01	Port 0, Bit 1	Input/Output
15	V <sub>SS</sub>	Ground	
16–20	P20–P24	Port 2, Bits 0,1,2,3,4	Input/Output

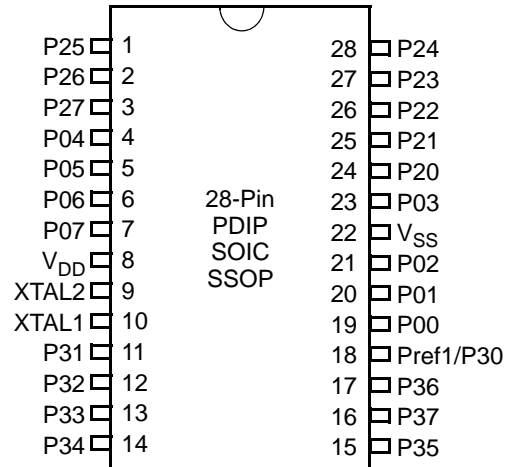

Figure 4. 28-Pin DIP/SOIC/SSOP Pin Configuration

Table 5. 28-Pin DIP/SOIC/SSOP Pin Identification

Pin	Symbol	Direction	Description
1-3	P25-P27	Input/Output	Port 2, Bits 5,6,7
4-7	P04-P07	Input/Output	Port 0, Bits 4,5,6,7
8	V <sub>DD</sub>		Power supply
9	XTAL2	Output	Crystal, oscillator clock
10	XTAL1	Input	Crystal, oscillator clock
11-13	P31-P33	Input	Port 3, Bits 1,2,3
14	P34	Output	Port 3, Bit 4
15	P35	Output	Port 3, Bit 5
16	P37	Output	Port 3, Bit 7
17	P36	Output	Port 3, Bit 6
18	Pref1	Input	Analog ref input; connect to V <sub>CC</sub> if not used Port 3 Bit 0
19-21	P00-P02	Input/Output	Port 0, Bits 0,1,2
22	V <sub>SS</sub>		Ground
23	P03	Input/Output	Port 0, Bit 3
24-28	P20-P24	Input/Output	Port 2, Bits 0-4

## Absolute Maximum Ratings

Stresses greater than those listed in [Table 6](#) might cause permanent damage to the device. This rating is a stress rating only. Functional operation of the device at

any condition above those indicated in the operational sections of these specifications is not implied. Exposure to absolute maximum rating conditions for an extended period might affect device reliability.

**Table 6. Absolute Maximum Ratings**

Parameter	Minimum	Maximum	Units	Notes
Ambient temperature under bias	0	+70	C	
Storage temperature	-65	+150	C	
Voltage on any pin with respect to $V_{SS}$	-0.3	+4.0	V	1
Voltage on $V_{DD}$ pin with respect to $V_{SS}$	-0.3	+3.6	V	
Maximum current on input and/or inactive output pin	-5	+5	mA	
Maximum output current from active output pin	-25	+25	mA	
Maximum current into $V_{DD}$ or out of $V_{SS}$		75	mA	

Note:

1. This voltage applies to all pins except the following:  $V_{DD}$ .

## Standard Test Conditions

The characteristics listed in this product specification apply for standard test conditions as noted. All voltages are referenced to GND. Positive current flows into the referenced pin (see [Figure 5](#)).

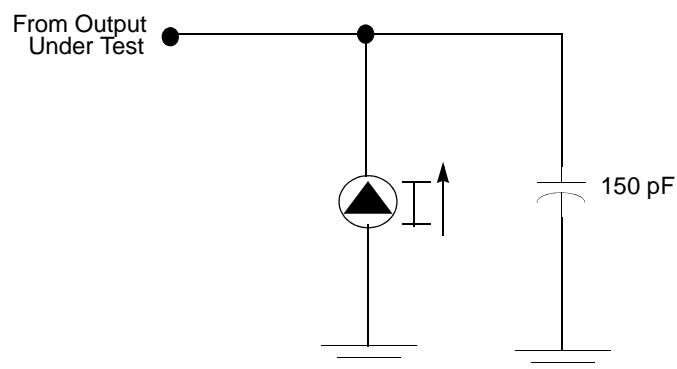

**Figure 5. Test Load Diagram**

## Capacitance

Table 7 lists the capacitances.

**Table 7. Capacitance**

Parameter	Maximum
Input capacitance	12pF
Output capacitance	12pF
I/O capacitance	12pF

Note:  $T_A = 25^\circ\text{C}$ ,  $V_{CC} = \text{GND} = 0\text{ V}$ ,  $f = 1.0\text{ MHz}$ , unmeasured pins returned to GND

## DC Characteristics

**Table 8. DC Characteristics**

Symbol	Parameter	$V_{CC}$	$T_A = 0^\circ\text{C to } +70^\circ\text{C}$			Units	Conditions	Notes
			Min	Typ(7)	Max			
$V_{CC}$	Supply Voltage		2.0 V		3.6	V	See Note 5	
$V_{CH}$	Clock Input High Voltage	2.0-3.6V	$0.8 V_{CC}$		$V_{CC}+0.3$	V	Driven by External Clock Generator	
$V_{CL}$	Clock Input Low Voltage	2.0-3.6V	$V_{SS}-0.3$		0.5	V	Driven by External Clock Generator	
$V_{IH}$	Input High Voltage	2.0-3.6V	$0.7 V_{CC}$		$V_{CC}+0.3$	V		
$V_{IL}$	Input Low Voltage	2.0-3.6V	$V_{SS}-0.3$		$0.2 V_{CC}$	V		
$V_{OH1}$	Output High Voltage	2.0-3.6V	$V_{CC}-0.4$			V	$I_{OH} = -0.5\text{mA}$	
$V_{OH2}$	Output High Voltage (P36, P37, P00, P01)	2.0-3.6V	$V_{CC}-0.8$			V	$I_{OH} = -7\text{mA}$	
$V_{OL1}$	Output Low Voltage	2.0-3.6V			0.4	V	$I_{OL} = 4.0\text{mA}$	
$V_{OL2}$	Output Low Voltage (P00, P01, P36, P37)	2.0-3.6V			0.8	V	$I_{OL} = 10\text{mA}$	
$V_{OFFSET}$	Comparator Input Offset Voltage	2.0-3.6V			25	mV		
$V_{REF}$	Comparator Reference Voltage	2.0-3.6V	0		$V_{DD}$ -1.75	V		
$I_{IL}$	Input Leakage	2.0-3.6V	-1		1	$\mu\text{A}$	$V_{IN} = 0\text{V}$ , $V_{CC}$ Pull-ups disabled	
$R_{PU}$	Pull-up Resistance	2.0V	225		675	$\text{K}\Omega$	$V_{IN} = 0\text{V}$ ; Pullups selected by mask option	
		3.6V	75		275	$\text{K}\Omega$		
$I_{OL}$	Output Leakage	2.0-3.6V	-1		1	$\mu\text{A}$	$V_{IN} = 0\text{V}$ , $V_{CC}$	
$I_{CC}$	Supply Current	2.0 V		1.2	3	mA	at 8.0MHz	1, 2
		3.6 V		2.1	5	mA	at 8.0MHz	1, 2



**Table 8. DC Characteristics (Continued)**

Symbol	Parameter	V <sub>CC</sub>	T <sub>A</sub> = 0°C to +70°C			Units	Conditions	Notes
			Min	Typ(7)	Max			
I <sub>CC1</sub>	Standby Current (HALT Mode)	2.0 V	0.5	1.6	mA	V <sub>IN</sub> = 0V, Clock at 8.0MHz Same as above	1, 2, 6 1, 2, 6	
		3.6 V	0.8	2.0	mA			
I <sub>CC2</sub>	Standby Current (STOP Mode)	2.0 V	1.2	8	μA	V <sub>IN</sub> = 0 V, V <sub>CC</sub> WDT is not Running Same as above V <sub>IN</sub> = 0 V, V <sub>CC</sub> WDT is Running Same as above	3 3 3 3	
		3.6 V	1.4	10	μA			
		2.0 V	3.5	20	μA			
		3.6 V	6.5	30	μA			
I <sub>LV</sub>	Standby Current (Low Voltage)		0.8	6	μA	Measured at 1.3V	4	
V <sub>BO</sub>	V <sub>CC</sub> Low Voltage Protection		1.8	2.0	V	8MHz maximum Ext. CLK Freq.		
V <sub>LVD</sub>	V <sub>CC</sub> Low Voltage Detection		2.4		V			
V <sub>HVD</sub>	V <sub>CC</sub> High Voltage Detection		2.7		V			

**Notes:**

1. All outputs unloaded, inputs at rail.
2. CL1 = CL2 = 100 pF.
3. Oscillator stopped.
4. Oscillator stops when V<sub>CC</sub> falls below V<sub>BO</sub> limit.
5. It is strongly recommended to add a filter capacitor (minimum 0.1 μF), physically close to VDD and V<sub>SS</sub> pins if operating voltage fluctuations are anticipated, such as those resulting from driving an IR LED.
6. Comparators and Timers are on. Interrupt disabled.
7. Typical values shown are at 25 degrees C.





# AC Characteristics

Figure 6 and Table 9 describe the Alternating Current (AC) characteristics.

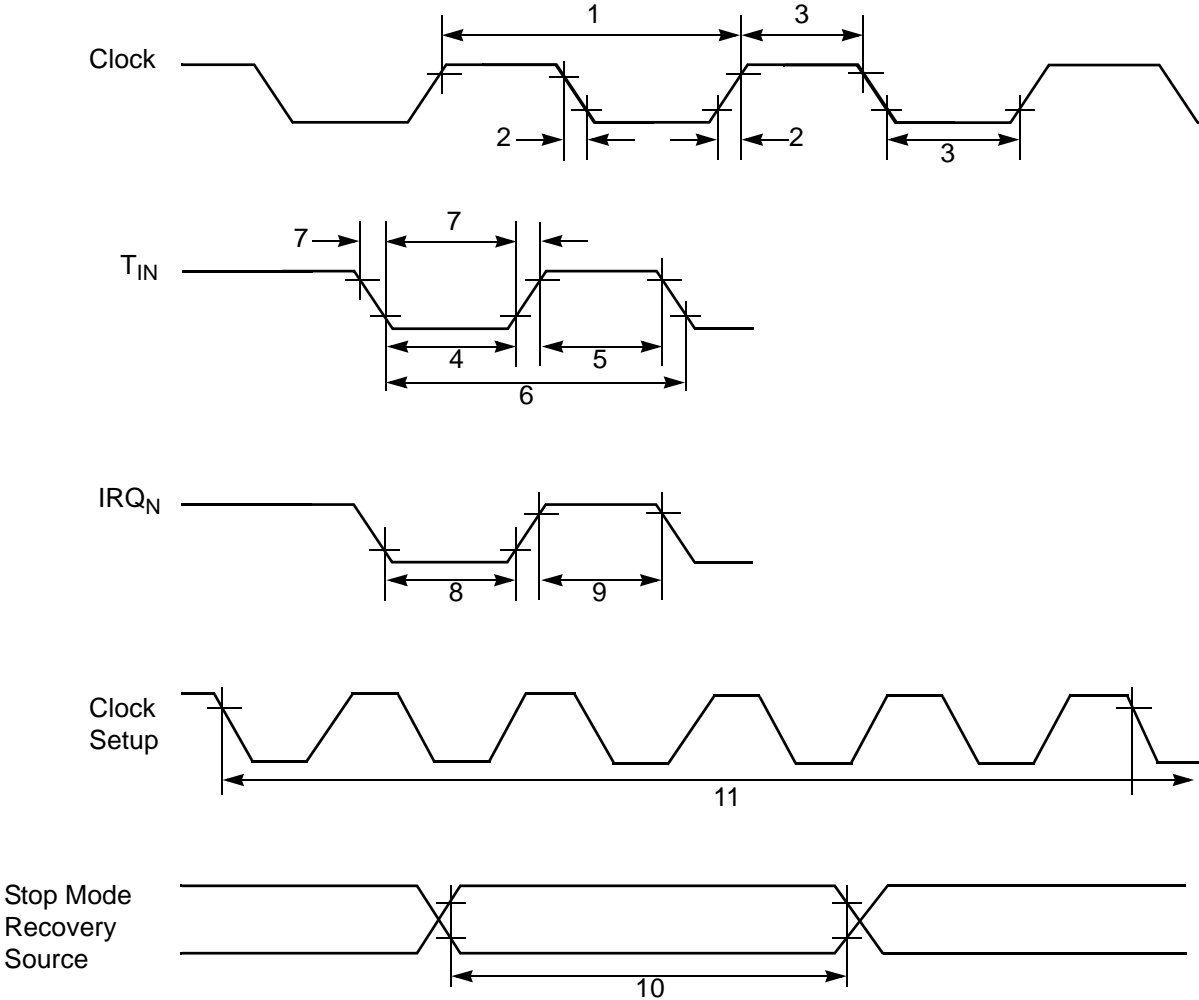

Figure 6. AC Timing Diagram



**Table 9. AC Characteristics**

No	Symbol	Parameter	V <sub>CC</sub>	T <sub>A</sub> =0°C to +70°C 8.0MHz		Units	Notes	Watch-Dog Timer Mode Register (D1, D0)
				Minimum	Maximum			
1	TpC	Input Clock Period	2.0–3.6	121	DC	ns	1	
2	TrC,TfC	Clock Input Rise and Fall Times	2.0–3.6		25	ns	1	
3	TwC	Input Clock Width	2.0–3.6	37		ns	1	
4	TwTinL	Timer Input Low Width	2.0	100		ns	1	
			3.6	70				
5	TwTinH	Timer Input High Width	2.0–3.6	3TpC			1	
6	TpTin	Timer Input Period	2.0–3.6	8TpC			1	
7	TrTin,TfTin	Timer Input Rise and Fall Timers	2.0–3.6		100	ns	1	
8	TwIL	Interrupt Request Low Time	2.0	100		ns	1, 2	
			3.6	70				
9	TwIH	Interrupt Request Input High Time	2.0–3.6	10TpC			1, 2	
10	TwsM	Stop-Mode Recovery Width Spec	2.0–3.6	12		ns	3	
				10TpC				
11	Tost	Oscillator Start-Up Time	2.0–3.6		5TpC		4	
12	Twdt	Watch-Dog Timer Delay Time	2.0–3.6	10		ms	0, 0	
				20		ms	0, 1	
				40		ms	1, 0	
				160		ms	1, 1	
13	T <sub>POR</sub>	Power-On Reset	2.0–3.6	2.5	10	ms		

Notes:

1. Timing Reference uses 0.9 V<sub>CC</sub> for a logic 1 and 0.1 V<sub>CC</sub> for a logic 0.
2. Interrupt request through Port 3 (P33–P31).
3. SMR – D5 = 1.
4. SMR – D5 = 0.

## Pin Functions

### XTAL1 Crystal 1 (Time-Based Input)

This pin connects a parallel-resonant crystal or ceramic resonator to the on-chip oscillator input. Additionally, an external single-phase clock can be connected to the on-chip oscillator input.

### XTAL2 Crystal 2 (Time-Based Output)

This pin connects a parallel-resonant crystal or ceramic resonator to the on-chip oscillator output.

## Input/Output Ports



**Caution:** The CMOS input buffer for each port 0, 1, or 2 pin is always connected to the pin, even when the pin is configured as an output. If the pin is configured as an open-drain output and no external signal is applied, a High output state can cause the CMOS input buffer to float. This might lead to excessive leakage current of more than 100  $\mu$ A. To prevent this leakage, connect the pin to an external signal with a defined logic level or ensure its output state is Low, especially during STOP mode.

Internal pull-ups are disabled on any given pin or group of port pins when programmed into output mode.

Port 0, 1, and 2 have both input and output capability. The input logic is always present no matter whether the port is configured as input or output. When doing a READ instruction, the MCU reads the actual value at the input logic but not from the output buffer. In addition, the instructions of OR, AND, and XOR have the Read-Modify-Write sequence. The MCU first reads the port, and then modifies the value and load back to the port.

Precaution must be taken if the port is configured as open-drain output or if the port is driving any circuit that makes the voltage different from the desired output logic. For example, pins P00–P07 are not connected to anything else. If it is configured as open-drain output with output logic as



ONE, it is a floating port and reads back as ZERO. The following instruction sets P00-P07 all LOW.

```
AND P0, #%F0
```

### Port 0 (P07–P00)

Port 0 is an 8-bit, bidirectional, CMOS-compatible port. These eight I/O lines are configured under software control as a nibble I/O port. The output drivers are push-pull or open-drain controlled by bit D2 in the PCON register.

If one or both nibbles are needed for I/O operation, they must be configured by writing to the Port 0 mode register. After a hardware reset, Port 0 is configured (Figure 7) as an input port.

An optional pull-up transistor is available as a mask option on all Port 0 bits with nibble select.

► **Note:** The Port 0 direction is reset to be input following an SMR.

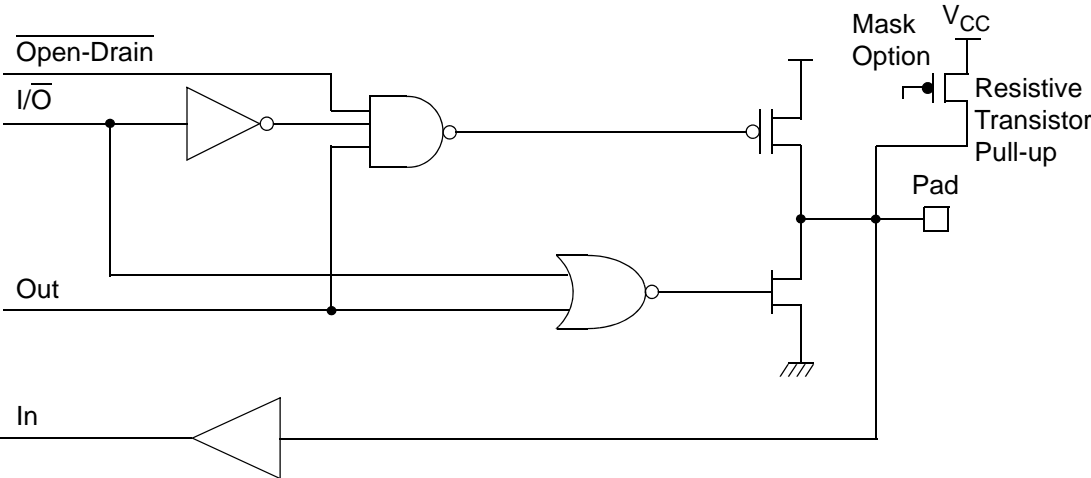
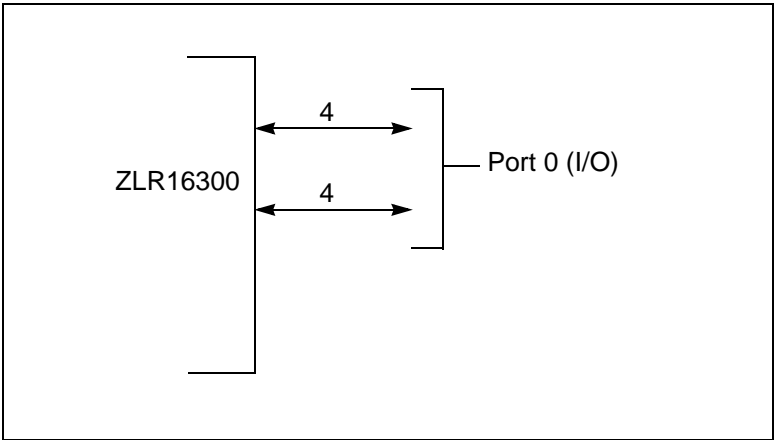

Figure 7. Port 0 Configuration

**Port 2 (P27–P20)**

Port 2 is an 8-bit, bidirectional, CMOS-compatible I/O port (see Figure 8). These eight I/O lines can be independently configured under software control as inputs or outputs. Port 2 is always available for I/O operation. A mask option is available to connect eight pull-up transistors on this port. Bits programmed as outputs are globally programmed as either push-pull or open-drain. The POR resets with the eight bits of Port 2 configured as inputs.

Port 2 also has an 8-bit input OR and AND gate, which can be used to wake up the part. P20 can be programmed to access the edge-detection circuitry in Demodulation mode.

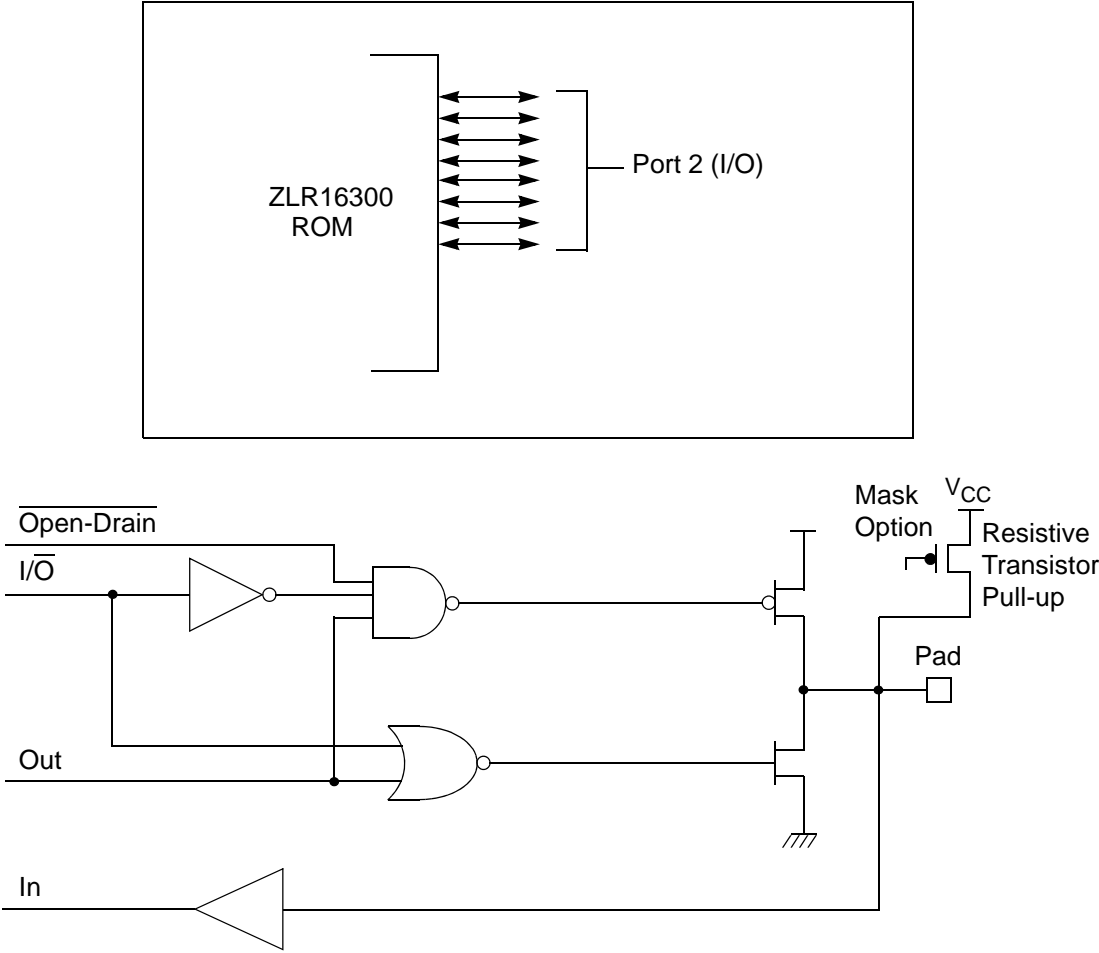
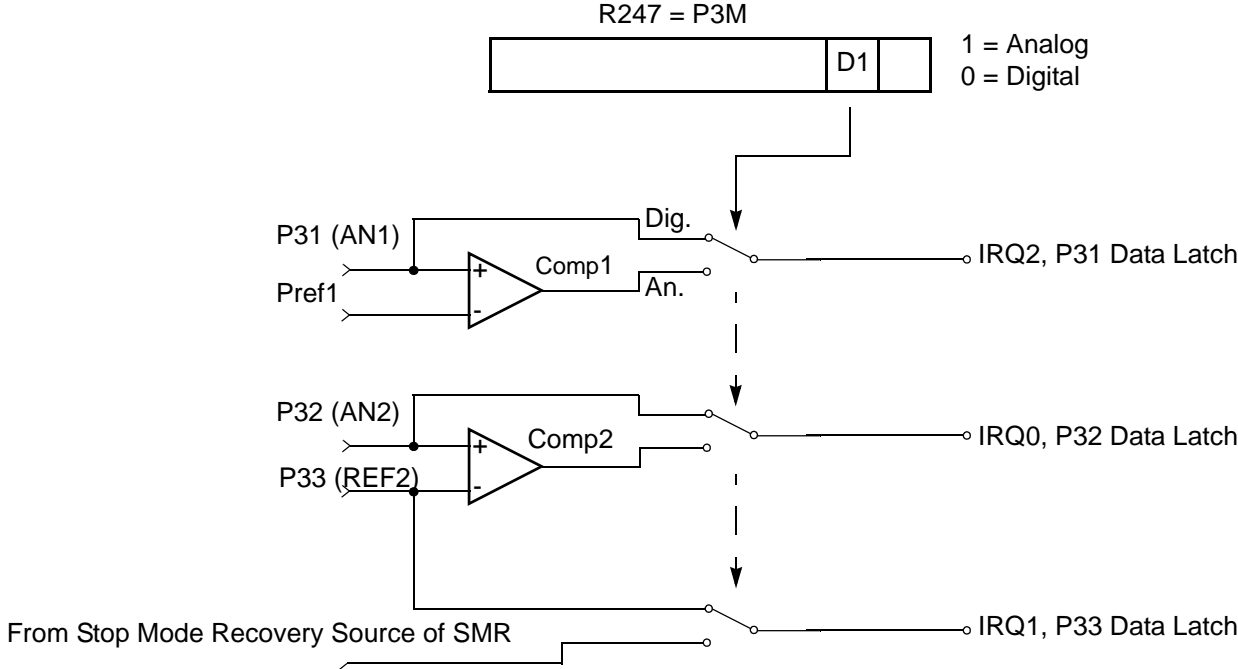
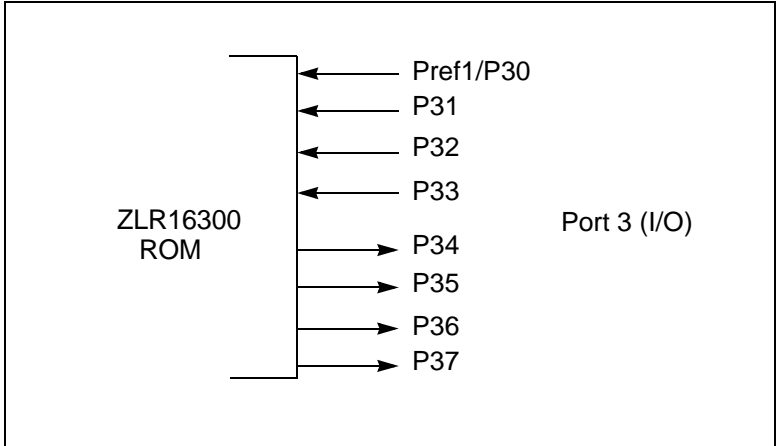

Figure 8. Port 2 Configuration

**Port 3 (P37–P30)**

Port 3 is an 8-bit, CMOS-compatible fixed I/O port (see Figure 9). Port 3 consists of four fixed input (P33–P30) and four fixed output (P37–P34), which can be configured under software control for interrupt and as output from the counter/timers. P30, P31, P32, and P33 are standard CMOS inputs; P34, P35, P36, and P37 are push-pull outputs.



**Figure 9. Port 3 Configuration**

Two on-board comparators process analog signals on P31 and P32, with reference to the voltage on Pref1 and P33. The analog function is enabled by programming the Port 3 Mode Register (bit 1). P31 and P32 are programmable as rising, falling, or both edge triggered interrupts (IRQ register bits 6 and 7). Pref1 and P33 are the comparator reference voltage inputs. Access to the Counter Timer edge-



detection circuit is through P31 or P20 (see [T8 and T16 Common Functions—CTR1\(OD\)01h on page 29](#)). Other edge detect and IRQ modes are described in [Table 10](#).

- ▶ **Note:** Comparators are powered down by entering Stop Mode. For P31–P33 to be used in a Stop Mode Recovery (SMR) source, these inputs must be placed into Digital mode.

**Table 10. Port 3 Pin Function Summary**

Pin	I/O	Counter/Timers	Comparator	Interrupt
Pref1/P30	IN		RF1	
P31	IN	IN	AN1	IRQ2
P32	IN		AN2	IRQ0
P33	IN		RF2	IRQ1
P34	OUT	T8	AO1	
P35	OUT	T16		
P36	OUT	T8/16		
P37	OUT		AO2	
P20	I/O	IN		

Port 3 also provides output for each of the counter/timers and the AND/OR Logic (see [Figure 10](#)). Control is performed by programming bits D5–D4 of CTR1, bit 0 of CTR0, and bit 0 of CTR2.



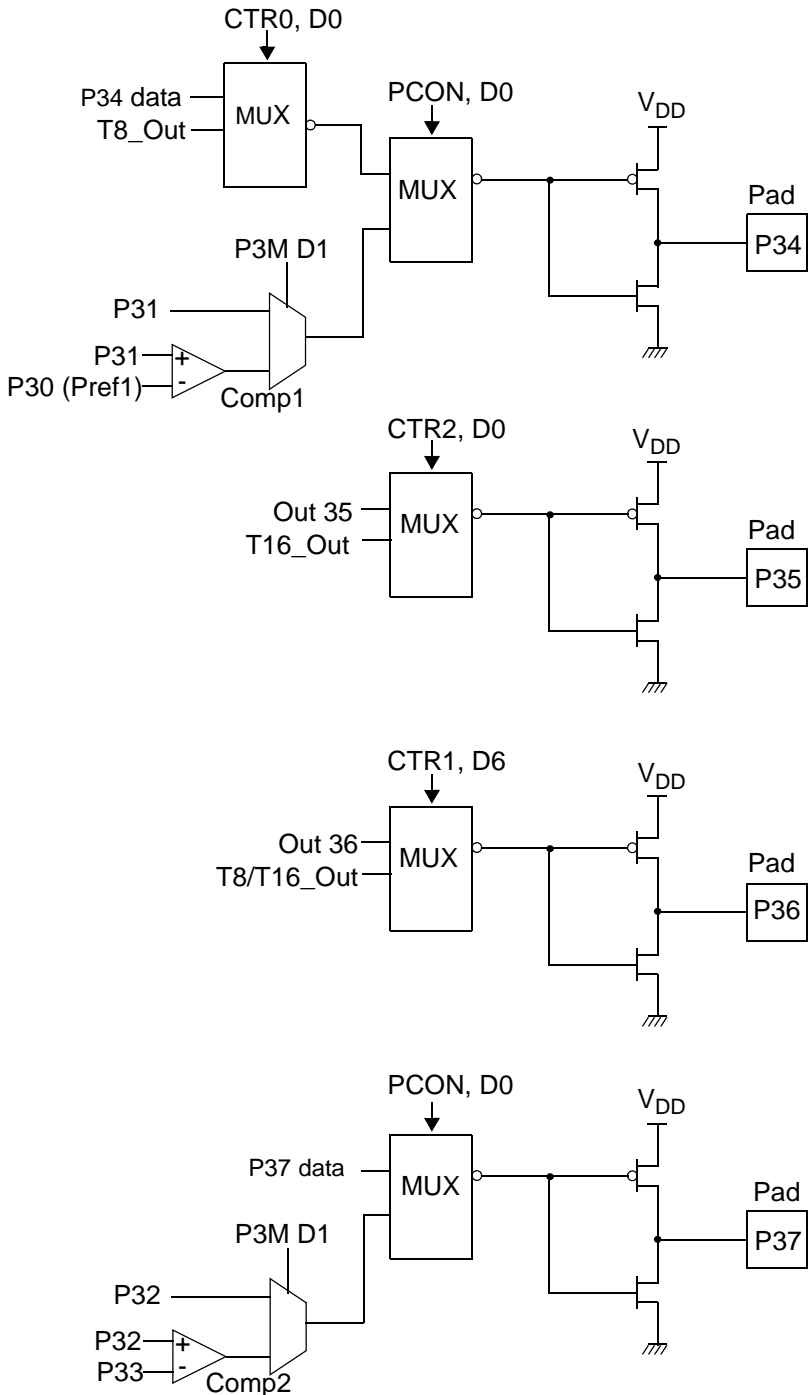

Figure 10. Port 3 Counter/Timer Output Configuration



### Comparator Inputs

In ANALOG mode, P31 and P32 have a comparator front end. The comparator reference is supplied to P33 and Pref1. In this mode, the P33 internal data latch and its corresponding IRQ1 are diverted to the SMR sources (excluding P31, P32, and P33) as indicated in [Figure 9](#) on page 16. In digital mode, P33 is used as D3 of the Port 3 input register, which then generates IRQ1.

- ▶ **Note:** Comparators are powered down by entering STOP mode. For P31–P33 to be used in a STOP Mode Recovery source, these inputs must be placed into Digital mode.

### Comparator Outputs

These channels can be programmed to be output on P34 and P37 through the PCON register.

## Functional Description

These devices incorporate special functions to enhance the Z8®'s functionality in consumer and battery-operated applications.

### Program Memory

These devices address from 1KB to 16KB of program memory. The first 12 Bytes are reserved for interrupt vectors. These locations contain the six 16-bit vectors that correspond to the six available interrupts. See [Figure 11](#).

### RAM

The ZLR16300 product family features 237 Bytes of RAM.

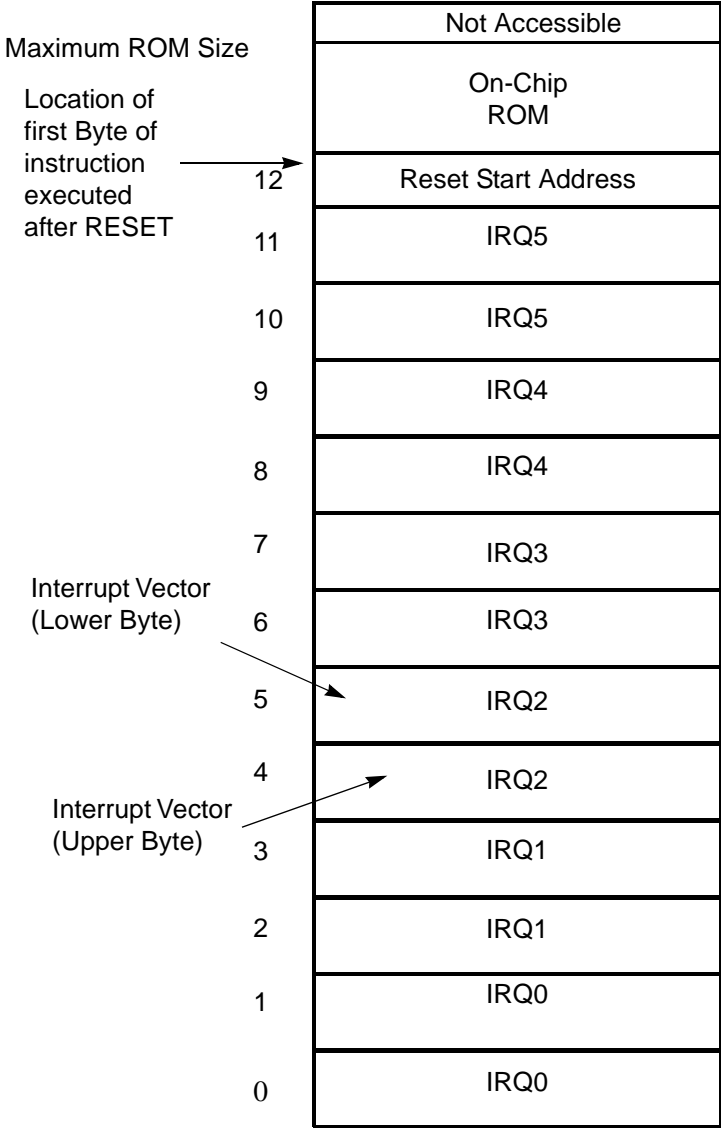

Figure 11. Program Memory Map



## Expanded Register File

The register file has been expanded to allow for additional system control registers and for mapping of additional peripheral devices into the register address area. The Z8® register address space (0 through 15 (0Fh)) has been implemented as 16 banks, with 16 registers per bank. These register banks are known as the ERF (Expanded Register File). Bits 7–4 of register RP select the working register group. Bits 3–0 of register RP select the expanded register file bank.

- ▶ **Note:** An expanded register bank is also referred to as an expanded register group (see [Figure 12](#)).

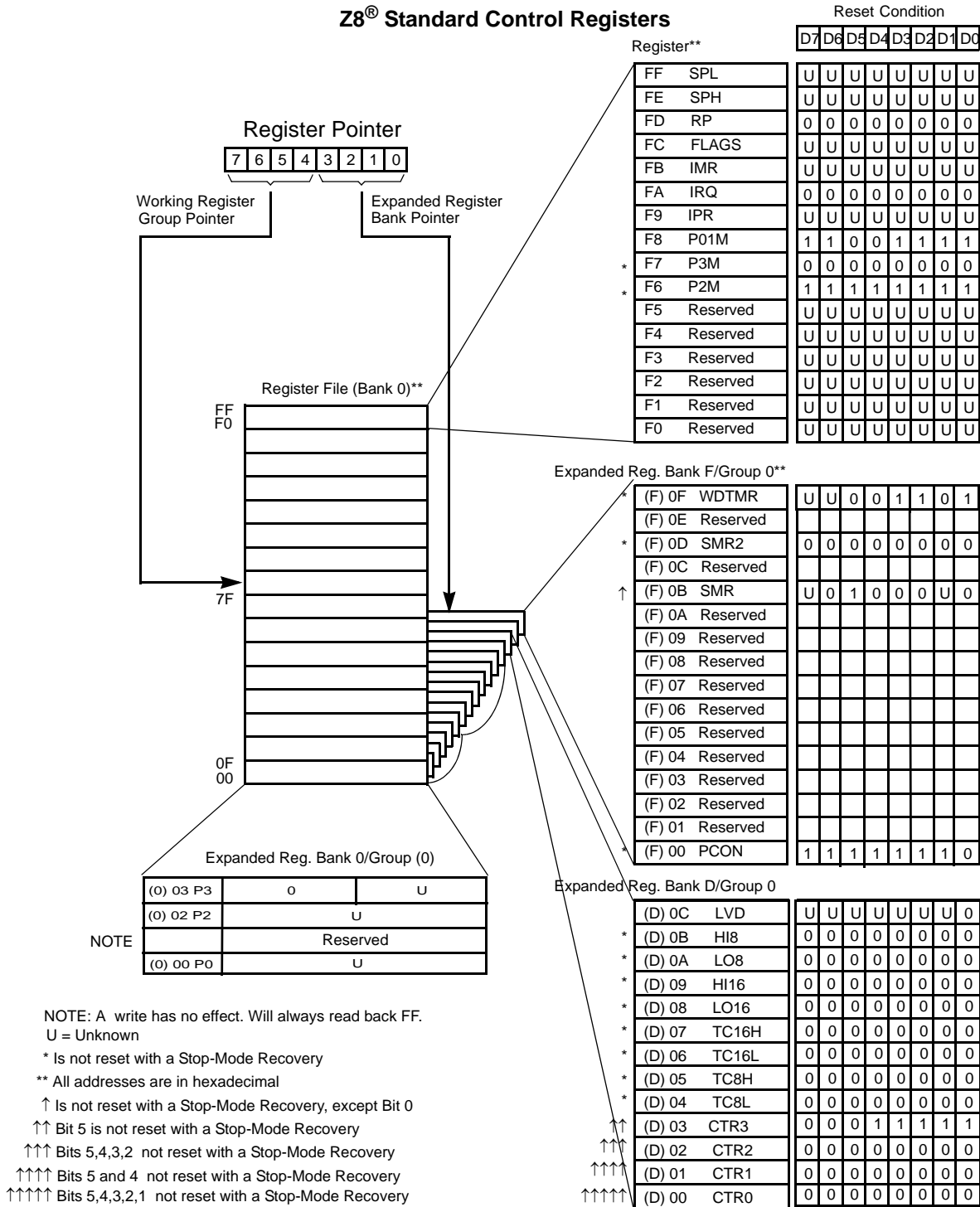
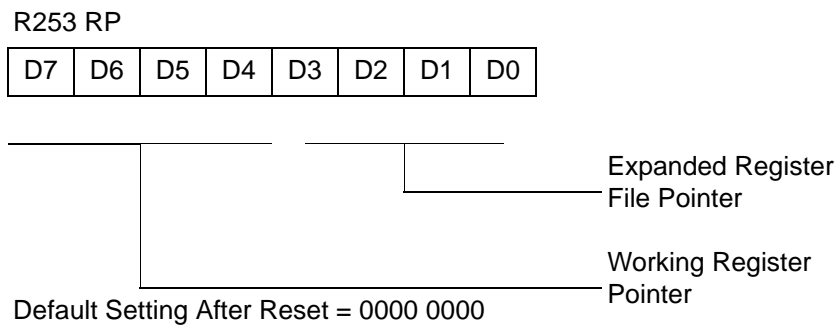

Figure 12. Expanded Register File Architecture



The upper nibble of the register pointer (see [Figure 13](#)) selects which working register group, of 16 bytes in the register file, is accessed out of the possible 256. The lower nibble selects the expanded register file bank and in the case of the Crimzon™ ZLR16300 family, banks 0, F, and D are implemented. A 0h in the lower nibble allows the normal register file (bank 0) to be addressed. Any other value from 1h to Fh exchanges the lower 16 registers to the selected expanded register bank.



**Figure 13. Register Pointer**

**Example: (See [Figure 12](#) on page 22)**

R253 RP = 00h  
R0 = Port 0  
R2 = Port 2  
R3 = Port 3

But if:

R253 RP = 0Dh  
R0 = CTR0  
R1 = CTR1  
R2 = CTR2  
R3 = CTR3



The counter/timers are mapped into ERF group D. Access is easily performed using the following:

```
LD                RP, #0Dh                ;Select ERF D for
                                                access to bank D
                                                ;(working register
group 0)
LD                R0, #xx                ;load CTR0
LD                1, #xx                ;load CTR1
LD                R1, 2                ;CTR2→CTR1

LD                RP, #0Dh                ;Select ERF D for
                                                access to bank D
                                                ; (working register
group 0)
LD                RP, #7Dh                ;Select expanded
register bank D and working                ;register group 7 of
bank 0 for access.
LD                71h, 2                ;CTRL2→register 71h
LD                R1, 2                ;CTRL2→register 71h
```

## Register File

The register file (bank 0) consists of 3 I/O port registers, 237 general-purpose registers, 16 control and status registers (R0, R2, R3, R4–R239, and R240–R255, respectively), and two expanded register Banks D (see [Table 11](#)) and F. Instructions can access registers directly or indirectly through an 8-bit address field, thereby allowing a short, 4-bit register address to use the Register Pointer ([Figure 14](#)). In the 4-bit mode, the register file is divided into 16 working register groups, each occupying 16 continuous locations. The Register Pointer addresses the starting location of the active working register group.

- **Note:** Register address E0h–EFh can only be accessed through working registers and indirect addressing modes.

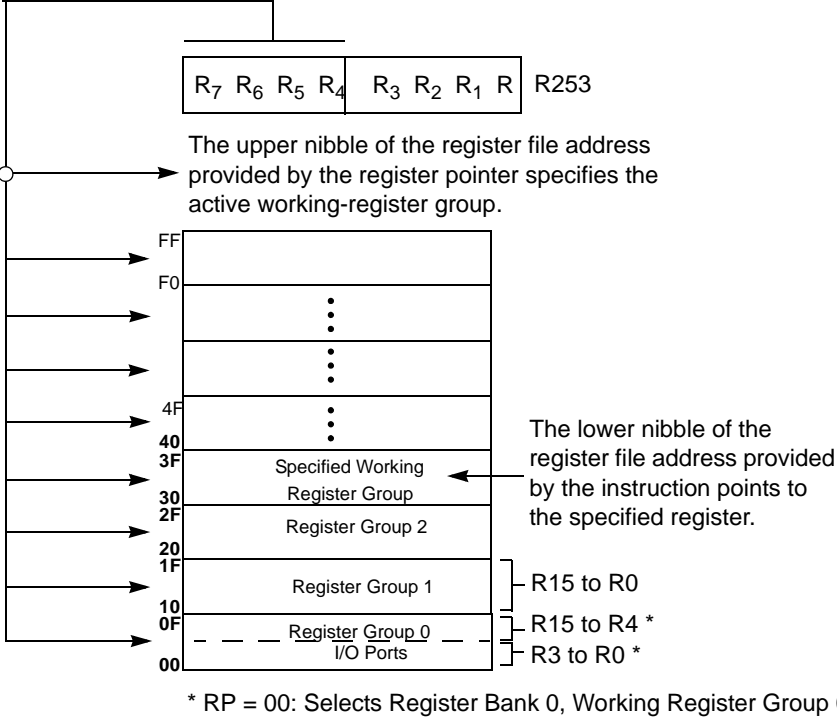

Figure 14. Register Pointer—Detail

**Stack**

The internal register file is used for the stack. An 8-bit Stack Pointer SPL (R255) is used for the internal stack that resides in the general-purpose registers (R4–R239). SPH (R254) can be used as a general-purpose register.





## Timers

### T8\_Capture\_HI—HI8(0D)0Bh

This register holds the captured data from the output of the 8-bit Counter/Timer0. Typically, this register holds the number of counts when the input signal is 1.

Field	Bit Position	Description
T8_Capture_HI	[7:0]	R/W Captured Data - No Effect

### T8\_Capture\_LO—L08(0D)0Ah

This register holds the captured data from the output of the 8-bit Counter/Timer0. Typically, this register holds the number of counts when the input signal is 0.

Field	Bit Position	Description
T8_Capture_LO	[7:0]	R/W Captured Data - No Effect

### T16\_Capture\_HI—HI16(0D)09h

This register holds the captured data from the output of the 16-bit Counter/Timer16. This register holds the MS-Byte of the data.

Field	Bit Position	Description
T16_Capture_HI	[7:0]	R/W Captured Data - No Effect

### T16\_Capture\_LO—L016(0D)08h

This register holds the captured data from the output of the 16-bit Counter/Timer16. This register holds the LS-Byte of the data.

Field	Bit Position	Description
T16_Capture_LO	[7:0]	R/W Captured Data - No Effect

### Counter/Timer2 MS-Byte Hold Register—TC16H(0D)07h

Field	Bit Position	Description
T16_Data_HI	[7:0]	R/W Data



### Counter/Timer2 LS-Byte Hold Register—TC16L(0D)06h

Field	Bit Position	Description
T16_Data_LO	[7:0]	R/W Data

### Counter/Timer8 High Hold Register—TC8H0(D)05h

Field	Bit Position	Description
T8_Level_HI	[7:0]	R/W Data

### Counter/Timer8 Low Hold Register—TC8L(0D)04h

Field	Bit Position	Description
T8_Level_LO	[7:0]	R/W Data

### CTR0 Counter/Timer8 Control Register—CTR0(0D)00h

Table 11 lists and briefly describes the fields for this register.

Table 11. CTR0(0D)00h Counter/Timer8 Control Register

Field	Bit Position		Value	Description
T8_Enable	7-----	R/W	0*	Counter Disabled
			1	Counter Enabled
			0	Stop Counter
			1	Enable Counter
Single/Modulo-N	-6-----	R/W	0*	Modulo-N
			1	Single Pass
Time_Out	--5-----	R/W	0**	No Counter Time-Out
			1	Counter Time-Out Occurred
			0	No Effect
			1	Reset Flag to 0
T8_Clock	---43---	R/W	0 0**	SCLK
			0 1	SCLK/2
			1 0	SCLK/4
			1 1	SCLK/8
Capture_INT_Mask	-----2--	R/W	0**	Disable Data Capture Interrupt
			1	Enable Data Capture Interrupt

Table 11. CTR0(0D)00h Counter/Timer8 Control Register (Continued)

Field	Bit Position		Value	Description
Counter_INT_Mask	-----1-	R/W	0**	Disable Time-Out Interrupt
			1	Enable Time-Out Interrupt
P34_Out	-----0	R/W	0*	P34 as Port Output
			1	T8 Output on P34

**Note:**

\*Indicates the value at Power-On Reset.

\*\* Indicates the value upon Power-On Reset. Not reset with a Stop Mode recovery.

**T8 Enable**

This field enables T8 when set (written) to 1.

**Single/Modulo-N**

When set to 0 (Modulo-N), the counter reloads the initial value when the terminal count is reached. When set to 1 (Single-Pass), the counter stops when the terminal count is reached.

**Timeout**

This bit is set when T8 times out (terminal count reached). To reset this bit, write a 1 to its location.



**Caution:** Writing a 1 is the only way to reset the Terminal Count status condition. Reset this bit before using/enabling the counter/timers.

The first clock of T8 might not have complete clock width and can occur any time when enabled.



**Note:** Take care when using the OR or AND commands to manipulate CTR0, bit 5 and CTR1, bits 0 and 1 (Demodulation Mode). These instructions use a Read-Modify-Write sequence in which the current status from the CTR0 and CTR1 registers is ORed or ANDed with the designated value and then written back into the registers.

**T8 Clock**

These bits define the frequency of the input signal to T8.



### Capture\_INT\_Mask

Set this bit to allow an interrupt when data is captured into either LO8 or HI8 upon a positive or negative edge detection in Capture Mode.

### Counter\_INT\_Mask

Set this bit to allow an interrupt when T8 has a timeout.

### P34\_Out

This bit defines whether P34 is used as a normal output pin or the T8 output.

### T8 and T16 Common Functions—CTR1(0D)01h

This register controls the functions in common with the T8 and T16.

[Table 12](#) lists and briefly describes the fields for this register.

**Table 12. CTR1(0D)01h T8 and T16 Common Functions**

Field	Bit Position		Value	Description
Mode	7-----	R/W	0*	Transmit Mode
			1	Demodulation Mode
P36_Out/ Capture_Input	-6-----	R/W	0*	Transmit Mode
			1	Port Output
			0*	T8/T16 Output
			1	Demodulation Mode
T8/T16_Logic/ Edge_Detect	--54----	R/W	0*	P31
			1	P20
			00**	Transmit Mode
			01	AND
			10	OR
			11	NOR
			00**	NAND
			01	Demodulation Mode
10	Falling Edge			
11	Rising Edge			
			10	Both Edges
			11	Reserved



**Table 12. CTR1(0D)01h T8 and T16 Common Functions (Continued)**

Field	Bit Position		Value	Description
Transmit_Submode/ Glitch_Filter	----32--	R/W	00	Transmit Mode
			01	Normal Operation
			10	Ping-Pong Mode
			11	T16_Out = 0
			00	T16_Out = 1
			01	Demodulation Mode
			00	No Filter
			01	4 SCLK Cycle
			10	8 SCLK Cycle
			11	Reserved
Initial_T8_Out/ Rising Edge	-----1-	R/W	0	Transmit Mode
			1	T8_OUT is 0 Initially
			0	T8_OUT is 1 Initially
			1	Demodulation Mode
		R	0	No Rising Edge
			1	Rising Edge Detected
		W	0	No Effect
			1	Reset Flag to 0
Initial_T16_Out/ Falling_Edge	-----0	R/W	0	Transmit Mode
			1	T16_OUT is 0 Initially
			0	T16_OUT is 1 Initially
			1	Demodulation Mode
		R	0	No Falling Edge
			1	Falling Edge Detected
		W	0	No Effect
			1	Reset Flag to 0

**Note:**

\*Default at Power-On Reset.

\*\* Indicates the value upon Power-On Reset. Not reset with a Stop Mode recovery.

**Mode**

If the result is 0, the counter/timers are in Transmit mode; otherwise, they are in Demodulation Mode.

**P36\_Out/Demodulator\_Input**

In Transmit Mode, this bit defines whether P36 is used as a normal output pin or the combined output of T8 and T16.

In Demodulation Mode, this bit defines whether the input signal to the Counter/ Timers is from P20 or P31.



If the input signal is from Port 31, a capture event may also generate an IRQ2 interrupt. To prevent generating an IRQ2, either disable the IRQ2 interrupt by clearing its IMR bit D2 or use P20 as the input.

#### **T8/T16\_Logic/Edge\_Detect**

In Transmit Mode, this field defines how the outputs of T8 and T16 are combined (AND, OR, NOR, NAND).

In Demodulation Mode, this field defines which edge should be detected by the edge detector.

#### **Transmit\_Submode/Glitch Filter**

In Transmit Mode, this field defines whether T8 and T16 are in the Ping-Pong mode or in independent normal operation mode. Setting this field to “Normal Operation Mode” terminates the “Ping-Pong Mode” operation. When set to 10, T16 is immediately forced to a 0; a setting of 11 forces T16 to output a 1.

In Demodulation Mode, this field defines the width of the glitch that must be filtered out.

#### **Initial\_T8\_Out/Rising\_Edge**

In Transmit Mode, if 0, the output of T8 is set to 0 when it starts to count. If 1, the output of T8 is set to 1 when it starts to count. When the counter is not enabled and this bit is set to 1 or 0, T8\_OUT is set to the opposite state of this bit. This ensures that when the clock is enabled, a transition occurs to the initial state set by CTR1, D1.

In Demodulation Mode, this bit is set to 1 when a rising edge is detected in the input signal. In order to reset the mode, a 1 should be written to this location.

#### **Initial\_T16 Out/Falling\_Edge**

In Transmit Mode, if it is 0, the output of T16 is set to 0 when it starts to count. If it is 1, the output of T16 is set to 1 when it starts to count. This bit is effective only in Normal or Ping-Pong Mode (CTR1, D3; D2). When the counter is not enabled and this bit is set, T16\_OUT is set to the opposite state of this bit. This ensures that when the clock is enabled, a transition occurs to the initial state set by CTR1, D0.

In Demodulation Mode, this bit is set to 1 when a falling edge is detected in the input signal. In order to reset it, a 1 should be written to this location.

- **Note:** Modifying CTR1 (D1 or D0) while the counters are enabled causes unpredictable output from T8/16\_OUT.

#### **CTR2 Counter/Timer 16 Control Register—CTR2(0D)02h**

[Table 13](#) lists and briefly describes the fields for this register.



**Table 13. CTR2(0D)02h: Counter/Timer16 Control Register**

Field	Bit Position		Value	Description	
T16_Enable	7-----	R	0*	Counter Disabled	
			1	Counter Enabled	
		W	0	Stop Counter	
			1	Enable Counter	
Single/Modulo-N	-6-----	R/W	0	Transmit Mode	
			1	Modulo-N	
				Single Pass	
			0	Demodulation Mode	
Time_Out	--5-----	R	0**	T16 Recognizes Edge	
			1	T16 Does Not Recognize Edge	
			W	0	No Counter Timeout
				1	Counter Timeout Occurred
T16_Clock	---43---	R/W	00**	No Effect	
			01	Reset Flag to 0	
			10	SCLK	
			11	SCLK/2	
Capture_INT_Mask	-----2--	R/W	0**	SCLK/4	
			1	SCLK/8	
Counter_INT_Mask	-----1-	R/W	0*	Disable Data Capture Int.	
P35_Out	-----0	R/W	0*	Enable Data Capture Int.	
			1	Disable Timeout Int.	
			0*	Enable Timeout Int.	
			1	P35 as Port Output	
			1	T16 Output on P35	

**Note:**

\*Indicates the value upon Power-On Reset.

\*\* Indicates the value upon Power-On Reset. Not reset with a Stop Mode recovery.

**T16\_Enable**

This field enables T16 when set to 1.

**Single/Modulo-N**

In Transmit Mode, when set to 0, the counter reloads the initial value when it reaches the terminal count. When set to 1, the counter stops when the terminal count is reached.



In Demodulation Mode, when set to 0, T16 captures and reloads on detection of all the edges. When set to 1, T16 captures and detects on the first edge but ignores the subsequent edges. For details, see the description of T16 Demodulation Mode on page 41.

**Time\_Out**

This bit is set when T16 times out (terminal count reached). To reset the bit, write a 1 to this location.

**T16\_Clock**

This bit defines the frequency of the input signal to Counter/Timer16.

**Capture\_INT\_Mask**

This bit is set to allow an interrupt when data is captured into LO16 and HI16.

**Counter\_INT\_Mask**

Set this bit to allow an interrupt when T16 times out.

**P35\_Out**

This bit defines whether P35 is used as a normal output pin or T16 output.

**CTR3 T8/T16 Control Register—CTR3(0D)03h**

Table 14 lists and briefly describes the fields for this register. This register allow the T8 and T16 counters to be synchronized.

**Table 14. CTR3(0D)03h T8/T16 Control Register**

T16_Enable	7-----	R	0*	Counter Disabled
		R	1	Counter Enabled
		W	0	Stop Counter
		W	1	Enable Counter
T8 Enable	-6-----	R/W	0**	Counter Disabled
			1	Counter Enabled
			0	Stop Counter
			1	Enable Counter
Sync Mode	--5-----	R/W	0*	Disable Sync Mode
			1	Enable Sync Mode
Reserved	---43210	R/W	1	Always reads 11111
			x	No Effect

\* Indicates the value upon Power-On Reset.

\*\*\* Indicates the value upon Power-On Reset. Not reset with a Stop Mode recovery.



## Counter/Timer Functional Blocks

### Input Circuit

The edge detector monitors the input signal on P31 or P20. Based on CTR1 D5–D4, a pulse is generated at the Pos Edge or Neg Edge line when an edge is detected. Glitches in the input signal that have a width less than specified (CTR1 D3, D2) are filtered out (see [Figure 15](#)).

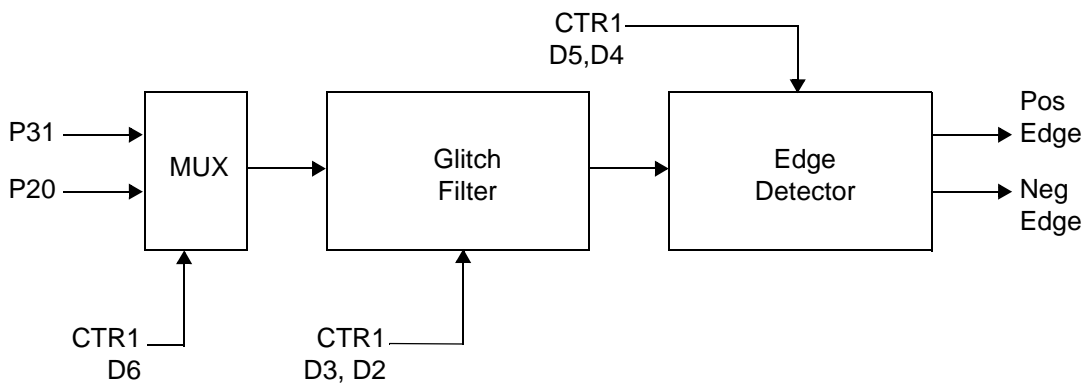

**Figure 15. Glitch Filter Circuitry**

### T8 Transmit Mode

Before T8 is enabled, the output of T8 depends on CTR1, D1. If it is 0, T8\_OUT is 1; if it is 1, T8\_OUT is 0. See [Figure 16](#).

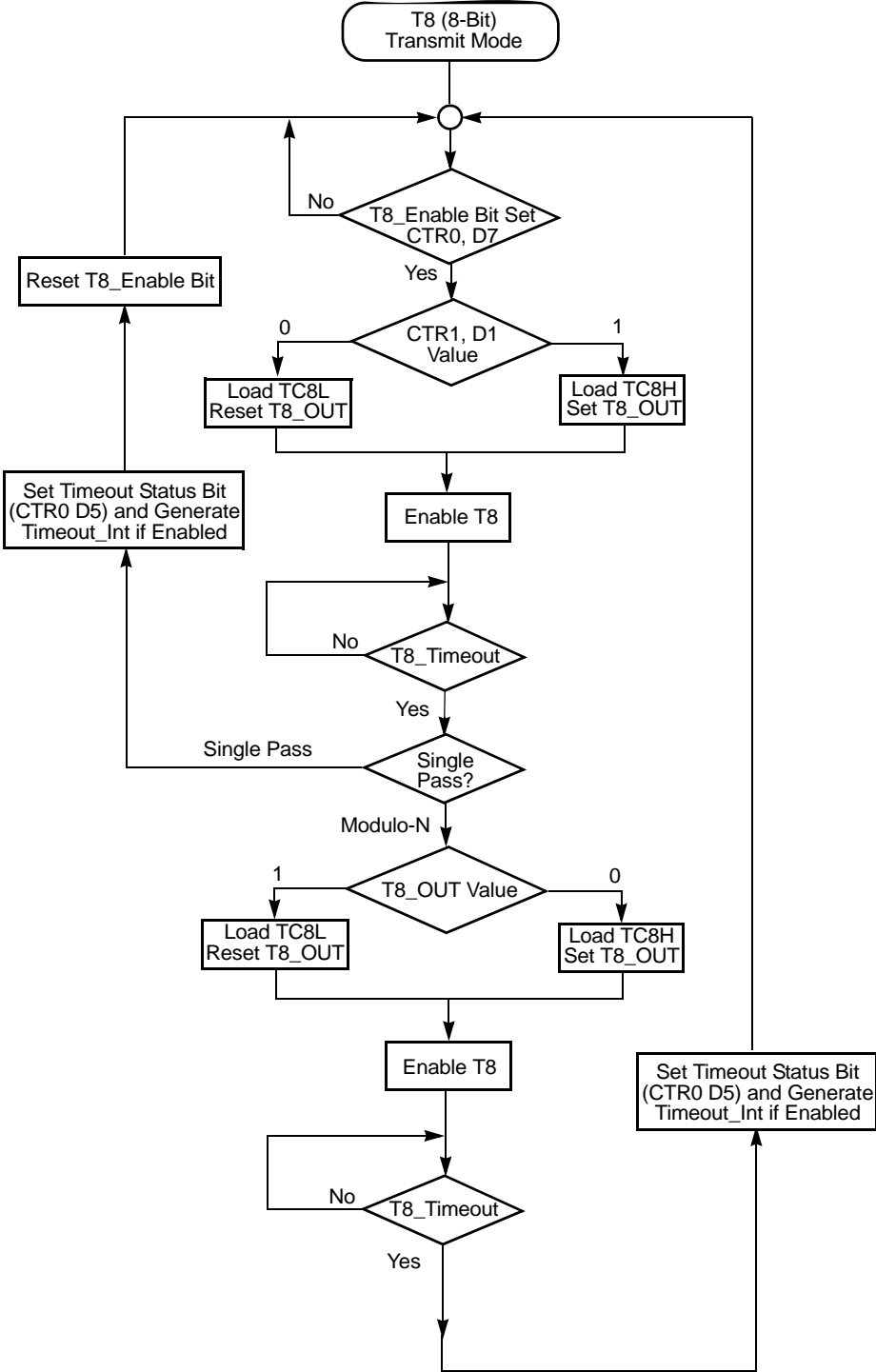

Figure 16. Transmit Mode Flowchart

When T8 is enabled, the output T8\_OUT switches to the initial value (CTR1, D1). If the initial value (CTR1, D1) is 0, TC8L is loaded; otherwise, TC8H is loaded into the counter. In Single-Pass Mode (CTR0, D6), T8 counts down to 0 and stops, T8\_OUT toggles, the timeout status bit (CTR0, D5) is set, and a timeout interrupt can be generated if it is enabled (CTR0, D1). In Modulo-N Mode, upon reaching terminal count, T8\_OUT is toggled, but no interrupt is generated. From that point, T8 loads a new count (if the T8\_OUT level now is 0), TC8L is loaded; if it is 1, TC8H is loaded. T8 counts down to 0, toggles T8\_OUT, and sets the timeout status bit (CTR0, D5), thereby generating an interrupt if enabled (CTR0, D1). One cycle is complete. T8 then loads from TC8H or TC8L according to the T8\_OUT level and repeats the cycle. See Figure 17.

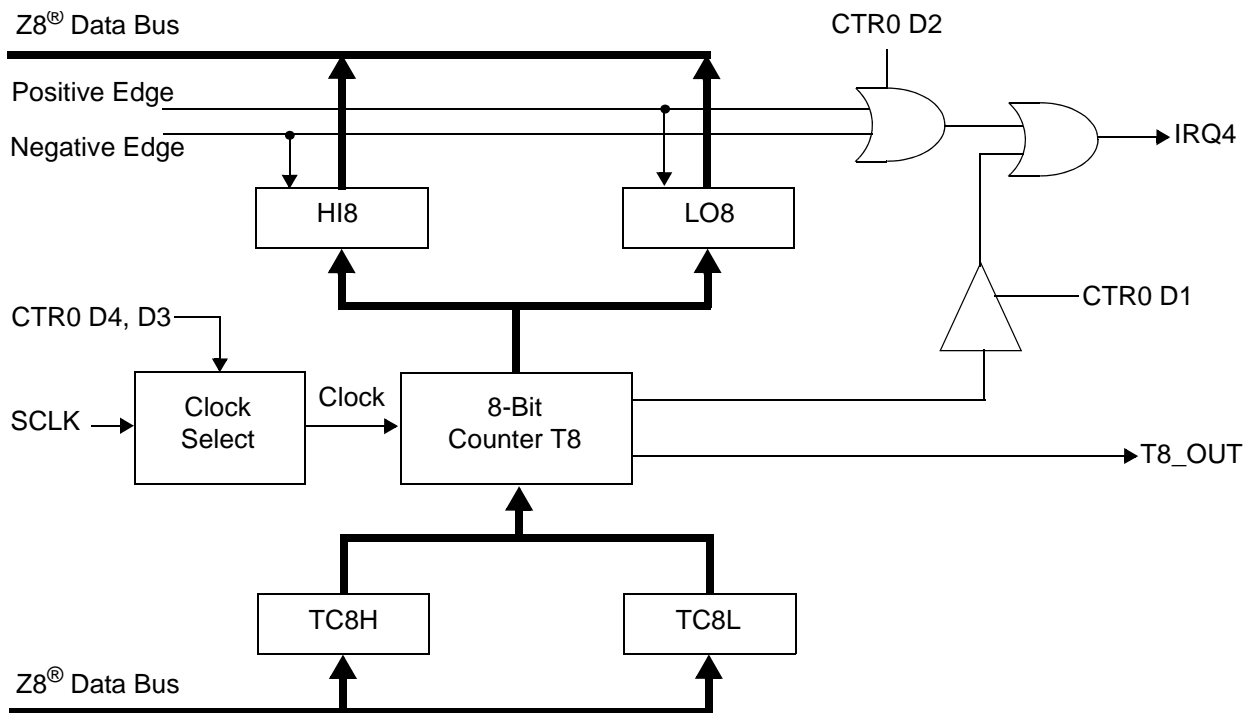

Figure 17. 8-Bit Counter/Timer Circuits

The values in TC8H or TC8L can be modified at any time. The new values take effect when they are loaded.



**Caution:** To ensure known operation do not write these registers at the time the values are to be loaded into the counter/timer. *An initial count of 1 is not allowed (a non-function occurs).* An initial count of 0 causes TC8 to count from 0 to FFh to FEh.

► **Note:** The letter *h* denotes hexadecimal values.

Transition from 0 to FF<sub>h</sub> is not a timeout condition.



**Caution:** Using the same instructions for stopping the counter/timers and setting the status bits is not recommended.

Two successive commands are necessary. First, the counter/timers must be stopped. Second, the status bits must be reset. These commands are required because it takes one counter/timer clock interval for the initiated event to actually occur. See [Figure 18](#) and [Figure 19](#).

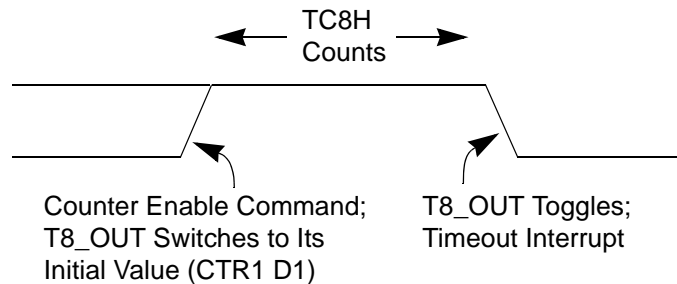

**Figure 18. T8\_OUT in Single-Pass Mode**

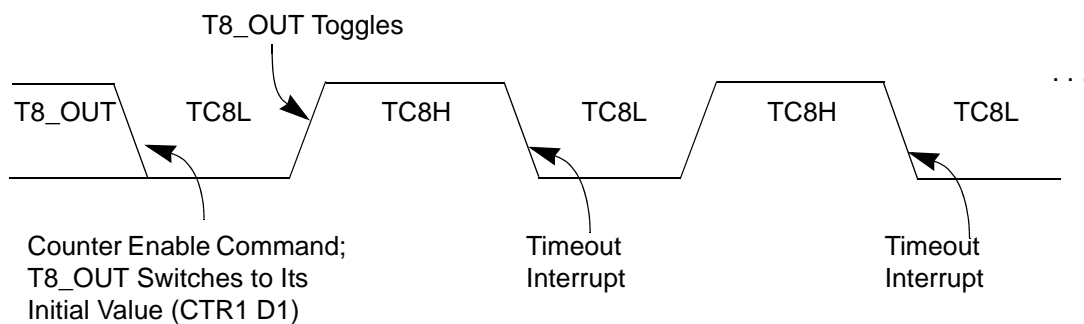

**Figure 19. T8\_OUT in Modulo-N Mode**

### T8 Demodulation Mode

The user must program TC8L and TC8H to FF<sub>h</sub>. After T8 is enabled, when the first edge (rising, falling, or both depending on CTR1, D5; D4) is detected, it starts to count down. When a subsequent edge (rising, falling, or both depending on CTR1, D5; D4) is detected during counting, the current value of T8 is complemented and put into one of the capture registers. If it is a positive edge, data is put into LO8; if it is a negative edge, data is put into HI8. From that point, one of the



edge detect status bits (CTR1, D1; D0) is set, and an interrupt can be generated if enabled (CTR0, D2). Meanwhile, T8 is loaded with FFh and starts counting again. If T8 reaches 0, the timeout status bit (CTR0, D5) is set, and an interrupt can be generated if enabled (CTR0, D1). T8 then continues counting from FFh (see Figures 21 and Figure 21).

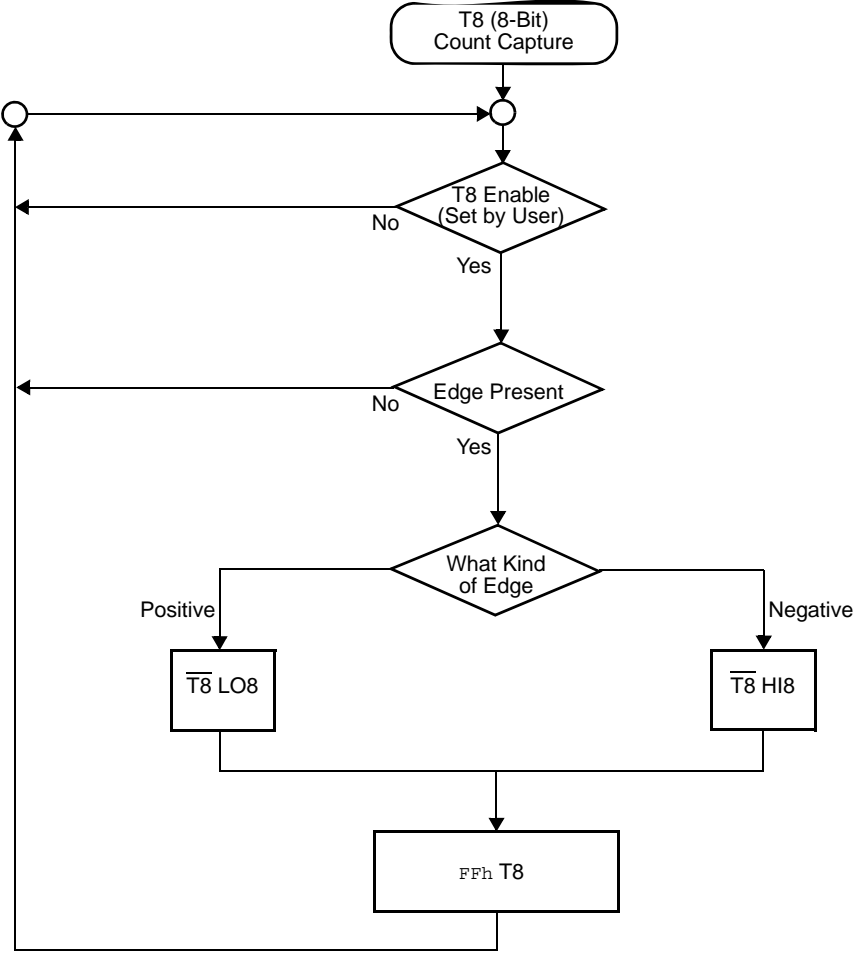

Figure 20. Demodulation Mode Count Capture Flowchart

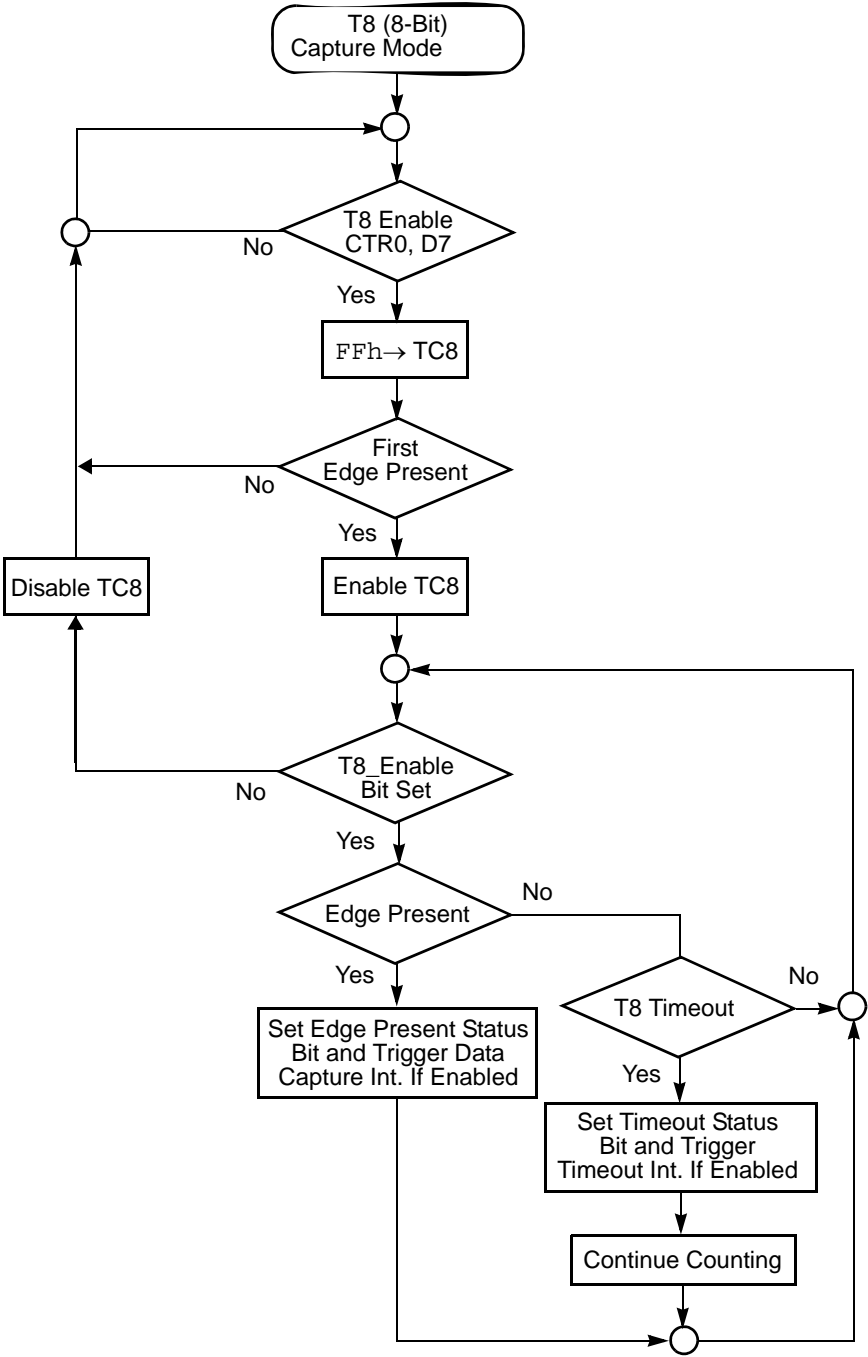

Figure 21. Demodulation Mode Flowchart

### T16 Transmit Mode

In Normal or Ping-Pong mode, the output of T16 when not enabled, is dependent on CTR1, D0. If it is a 0, T16\_OUT is a 1; if it is a 1, T16\_OUT is 0. You can force the output of T16 to either a 0 or 1 whether it is enabled or not by programming CTR1 D3; D2 to a 10 or 11.

When T16 is enabled, TC16H \* 256 + TC16L is loaded, and T16\_OUT is switched to its initial value (CTR1, D0). When T16 counts down to 0, T16\_OUT is toggled (in NORMAL or PING-PONG mode), an interrupt (CTR2, D1) is generated (if enabled), and a status bit (CTR2, D5) is set. See [Figure 22](#).

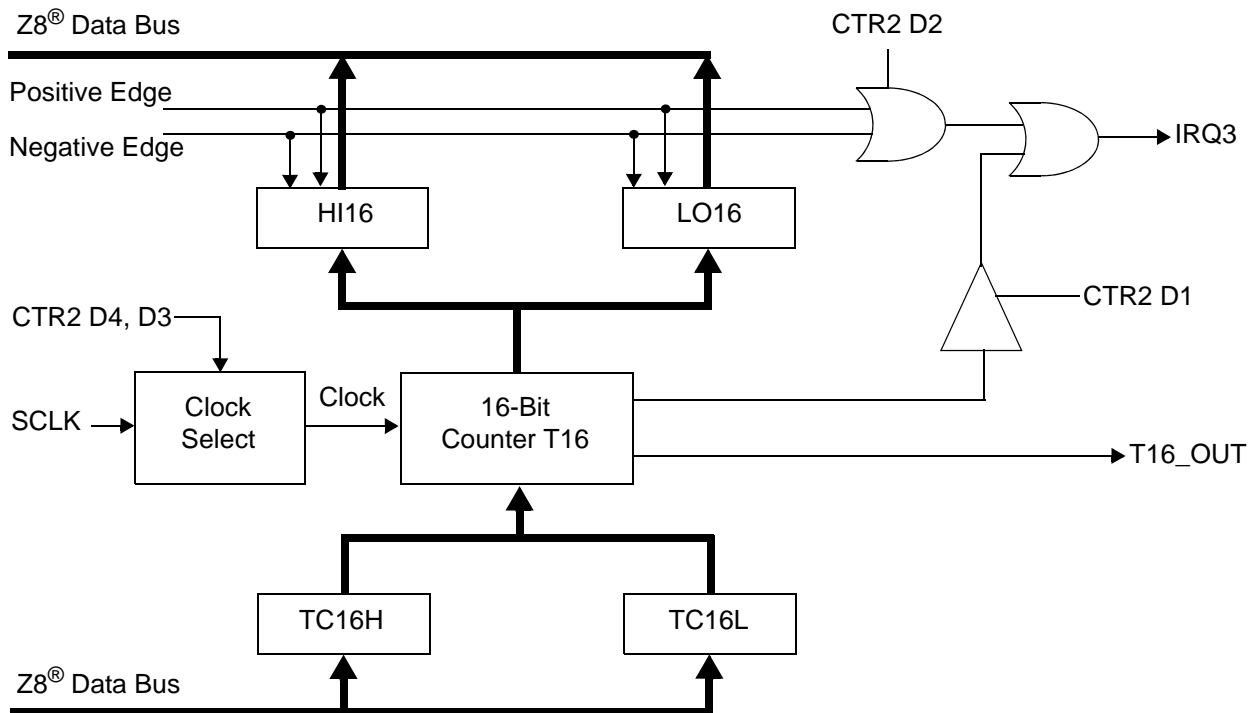

Figure 22. 16-Bit Counter/Timer Circuits

► **Note:** Global interrupts override this function as described in [Interrupts on page 44](#).

If T16 is in Single-Pass mode, it is stopped at this point (see [Figure 23](#)). If it is in Modulo-N Mode, it is loaded with TC16H \* 256 + TC16L, and the counting continues (see [Figure 24](#)).

The values in TC16H and TC16L can be modified at any time. The new values take effect when they are loaded.



**Caution:**

Do not load these registers at the time the values are to be loaded into the counter/timer to ensure known operation. An initial count of 1 is not allowed. An initial count of 0 causes T16 to count from 0 to FFFFh to FFFEh. Transition from 0 to FFFFh is not a timeout condition.

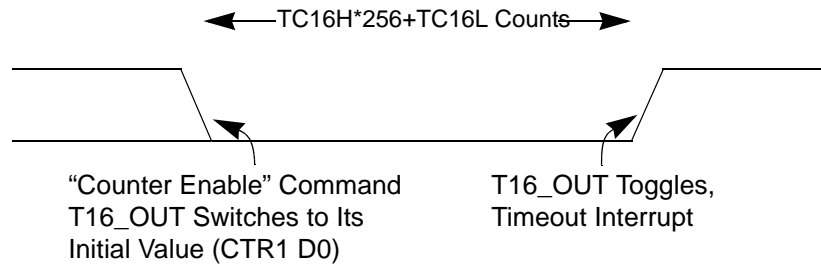

**Figure 23. T16\_OUT in Single-Pass Mode**

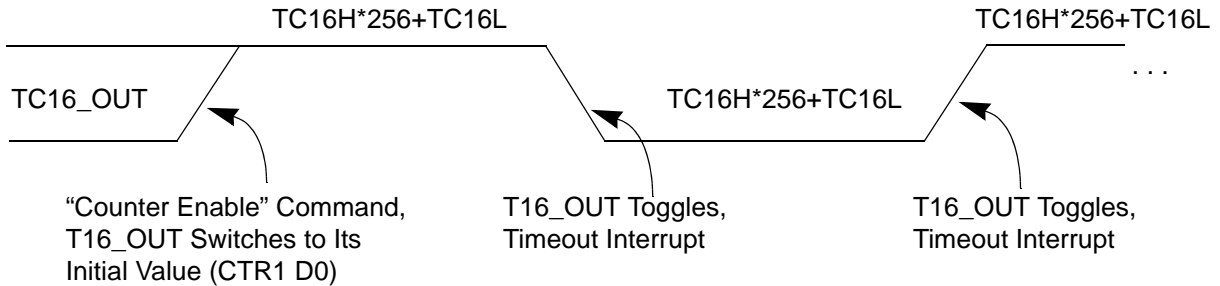

**Figure 24. T16\_OUT in Modulo-N Mode**

**T16 Demodulation Mode**

The user must program TC16L and TC16H to FFh. After T16 is enabled, and the first edge (rising, falling, or both depending on CTR1 D5; D4) is detected, T16 captures HI16 and LO16, reloads, and begins counting.

**If D6 of CTR2 Is 0**

When a subsequent edge (rising, falling, or both depending on CTR1, D5; D4) is detected during counting, the current count in T16 is complemented and put into HI16 and LO16. When data is captured, one of the edge detect status bits (CTR1, D1; D0) is set, and an interrupt is generated if enabled (CTR2, D2). T16 is loaded with FFFFh and starts again.

This T16 mode is generally used to measure space time, the length of time between bursts of carrier signal (marks).





### If D6 of CTR2 Is 1

T16 ignores the subsequent edges in the input signal and continues counting down. A timeout of T8 causes T16 to capture its current value and generate an interrupt if enabled (CTR2, D2). In this case, T16 does not reload and continues counting. If the D6 bit of CTR2 is toggled (by writing a 0 then a 1 to it), T16 captures and reloads on the next edge (rising, falling, or both depending on CTR1, D5; D4), continuing to ignore subsequent edges.

This T16 mode generally measures mark time, the length of an active carrier signal burst.

If T16 reaches 0, T16 continues counting from `FFFFh`. Meanwhile, a status bit (CTR2 D5) is set, and an interrupt timeout can be generated if enabled (CTR2 D1).

### Ping-Pong Mode

This operation mode is only valid in Transmit Mode. T8 and T16 must be programmed in Single-Pass mode (CTR0, D6; CTR2, D6), and Ping-Pong mode must be programmed in CTR1, D3; D2. The user can begin the operation by enabling either T8 or T16 (CTR0, D7 or CTR2, D7). For example, if T8 is enabled, T8\_OUT is set to this initial value (CTR1, D1). According to T8\_OUT's level, TC8H or TC8L is loaded into T8. After the terminal count is reached, T8 is disabled, and T16 is enabled. T16\_OUT then switches to its initial value (CTR1, D0), data from TC16H and TC16L is loaded, and T16 starts to count. After T16 reaches the terminal count, it stops, T8 is enabled again, repeating the entire cycle. Interrupts can be allowed when T8 or T16 reaches terminal control (CTR0, D1; CTR2, D1). To stop the ping-pong operation, write 00 to bits D3 and D2 of CTR1. See [Figure 25](#).

- **Note:** Enabling ping-pong operation while the counter/timers are running might cause intermittent counter/timer function. Disable the counter/timers and reset the status flags before instituting this operation.

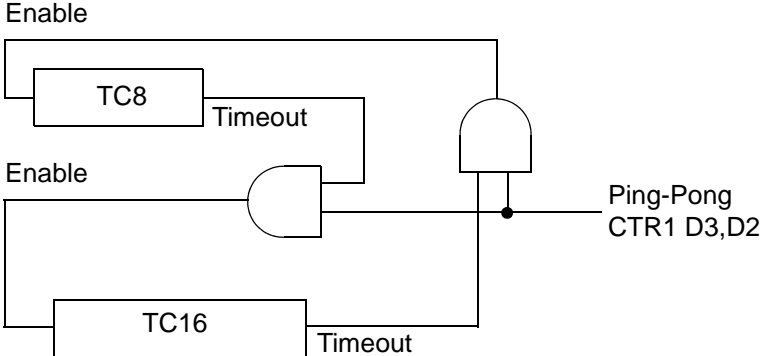

Figure 25. Ping-Pong Mode Diagram

**Initiating Ping-Pong Mode**

First, make sure both counter/timers are not running. Set T8 into Single-Pass mode (CTR0, D6), set T16 into Single-Pass mode (CTR2, D6), and set the Ping-Pong mode (CTR1, D2; D3). These instructions can be in random order. Finally, start Ping-Pong mode by enabling either T8 (CTR0, D7) or T16 (CTR2, D7). See Figure 25.

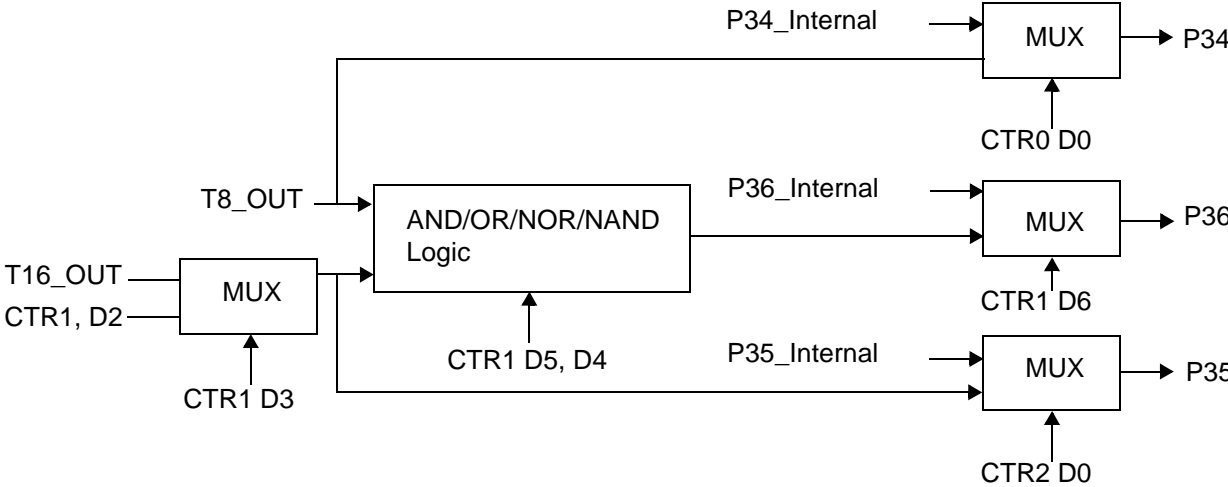

Figure 26. Output Circuit

The initial value of T8 or T16 must not be 1. If you stop the timer and restart the timer, reload the initial value to avoid an unknown previous value.



### During Ping-Pong Mode

The enable bits of T8 and T16 (CTR0, D7; CTR2, D7) are set and cleared alternately by hardware. The timeout bits (CTR0, D5; CTR2, D5) are set every time the counter/timers reach the terminal count.

### Timer Output

The output logic for the timers is illustrated in Figure 26. P34 is used to output T8-OUT when D0 of CTR0 is set. P35 is used to output the value of T16-OUT when D0 of CTR2 is set. When D6 of CTR1 is set, P36 outputs the logic combination of T8-OUT and T16-OUT determined by D5 and D4 of CTR1.

## Interrupts

The Crimzon™ ZLR16300 features six different interrupts ([Table 15](#)). The interrupts are maskable and prioritized ([Figure 27](#)). The six sources are divided as follows: three sources are claimed by Port 3 lines P33–P31, two by the counter/timers ([Table 15](#)) and one for low voltage detection. The Interrupt Mask Register (globally or individually) enables or disables the six interrupt requests.

The source for IRQ is determined by bit 1 of the Port 3 mode register (P3M). When in digital mode, Pin P33 is the source. When in analog mode the output of the Stop Mode Recovery source logic is used as the source for the interrupt. See [Figure 32-Stop Mode Recovery Source on page 53](#).

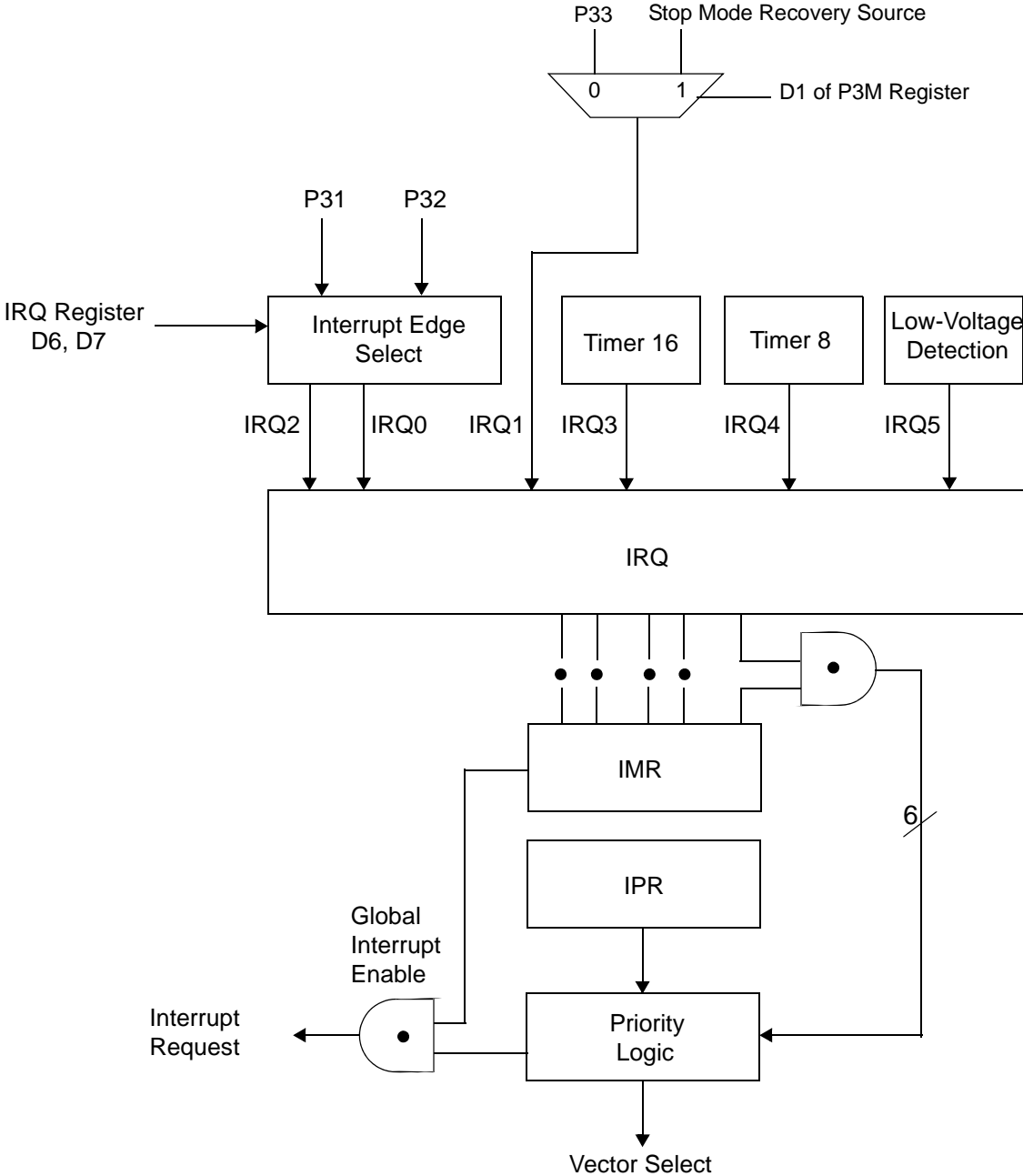

Figure 27. Interrupt Block Diagram



**Table 15. Interrupt Types, Sources, and Vectors**

Name	Source	Vector Location	Comments
IRQ0	P32	0,1	External (P32), Rising, Falling Edge Triggered
IRQ1	P33	2,3	External (P33), Falling Edge Triggered
IRQ2	P31, T <sub>IN</sub>	4,5	External (P31), Rising, Falling Edge Triggered
IRQ3	T16	6,7	Internal
IRQ4	T8	8,9	Internal
IRQ5	LVD	10,11	Internal

When more than one interrupt is pending, priorities are resolved by a programmable priority encoder controlled by the Interrupt Priority Register. An interrupt machine cycle activates when an interrupt request is granted. As a result, all subsequent interrupts are disabled, and the Program Counter and Status Flags are saved. The cycle then branches to the program memory vector location reserved for that interrupt. All Crimzon™ ZLR16300 interrupts are vectored through locations in the program memory. This memory location and the next byte contain the 16-bit address of the interrupt service routine for that particular interrupt request. To accommodate polled interrupt systems, interrupt inputs are masked, and the Interrupt Request register is polled to determine which of the interrupt requests require service.

An interrupt resulting from AN1 is mapped into IRQ2, and an interrupt from AN2 is mapped into IRQ0. Interrupts IRQ2 and IRQ0 can be rising, falling, or both edge triggered. These interrupts are programmable by the user. The software can poll to identify the state of the pin.

Programming bits for the Interrupt Edge Select are located in the IRQ Register (R250), bits D7 and D6. The configuration is indicated in [Table 16](#).

**Table 16. IRQ Register**

IRQ		Interrupt Edge	
D7	D6	IRQ2 (P31)	IRQ0 (P32)
0	0	F	F
0	1	F	R
1	0	R	F
1	1	R/F	R/F

**Note:** F = Falling Edge; R = Rising Edge

## Clock

The device's on-chip oscillator has a high-gain, parallel-resonant amplifier, for connection to a crystal, ceramic resonator, or any suitable external clock source (XTAL1 = Input, XTAL2 = Output). The crystal must be AT cut, 1 MHz to 8 MHz maximum, with a series resistance (RS) less than or equal to 100  $\Omega$ . The on-chip oscillator can be driven with a suitable external clock source.

The crystal must be connected across XTAL1 and XTAL2 using the recommended capacitors from each pin to ground. The typical capacitor value is 10pF for 8MHz. Also check with the crystal supplier for the optimum capacitance.

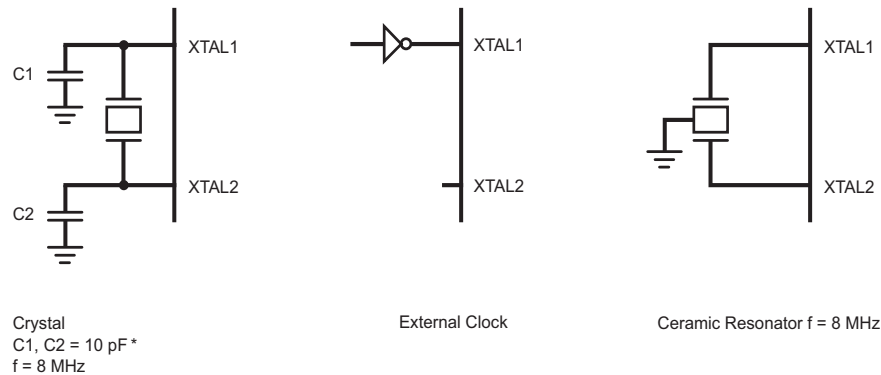

\*Note: preliminary value.

**Figure 28. Oscillator Configuration**

ZiLOG IR MCU supports crystal, resonator, and oscillator. Most resonators have a frequency tolerance of less than  $\pm 0.5\%$ , which is enough for remote control application. Resonator has a very fast startup time, which is around few hundred microseconds. Most crystals have a frequency tolerance of less than 50 ppm ( $\pm 0.005\%$ ). However, crystal needs longer startup time than the resonator. The large loading capacitance slows down the oscillation startup time. ZiLOG suggests not to use more than 10pF loading capacitor for the crystal. If the stray capacitance of the PCB or the crystal is high, the loading capacitance C1 and C2 must be reduced further to ensure stable oscillation before the  $T_{POR}$  (Power-On Reset time is typically 5-6 ms. Refer to [AC Characteristics in Table 9](#)).

For Stop Mode Recovery operation, bit 5 of SMR register allows you to select the STOP mode recovery delay, which is the  $T_{POR}$ . If STOP mode recovery delay is not selected, the MCU executes instruction immediately after it wakes up from the



STOP mode. If resonator or crystal is used as a clock source then STOP mode recovery delay needs to be selected (bit 5 of SMR = 1).

For both resonator and crystal oscillator, the oscillation ground must go directly to the ground pin of the microcontroller. The oscillation ground must use the shortest distance from the microcontroller ground pin and it must be isolated from other connections.

## Power Management

### Power-On Reset

A timer circuit clocked by a dedicated on-board RC-oscillator is used for the Power-On Reset (POR) timer function. The POR time allows  $V_{DD}$  and the oscillator circuit to stabilize before instruction execution begins.

The POR timer circuit is a one-shot timer triggered by one of three conditions:

- Power Fail to Power OK status, including Waking up from  $V_{BO}$  Standby
- Stop-Mode Recovery (if D5 of SMR = 1)
- WDT Timeout

The POR timer is 2.5 ms minimum. Bit 5 of the Stop-Mode Register determines whether the POR timer is bypassed after Stop-Mode Recovery (typical for external clock).

### Halt Mode

This instruction turns off the internal CPU clock, but not the XTAL oscillation. The counter/timers and external interrupts IRQ0, IRQ1, IRQ2, IRQ3, IRQ4, and IRQ5 remain active. The devices are recovered by interrupts, either externally or internally generated. An interrupt request must be executed (enabled) to exit Halt Mode. After the interrupt service routine, the program continues from the instruction after the Halt.

### Stop Mode

This instruction turns off the internal clock and external crystal oscillation, reducing the standby current to 10  $\mu$ A or less. Stop Mode is terminated only by a reset, such as WDT timeout, POR or SMR. This condition causes the processor to restart the application program at address 000Ch. In order to enter Stop (or Halt) mode, first flush the instruction pipeline to avoid suspending execution in mid-instruction. Execute an NOP instruction (Opcode = FFh) immediately before the appropriate sleep instruction, as follows:

```

FF      NOP      ; clear the pipeline
6F      STOP     ; enter Stop Mode

or

FF      NOP      ; clear the pipeline
7F      HALT     ; enter Halt Mode
    
```

## Port Configuration

### Port Configuration Register

The Port Configuration (PCON) register (Figure 29) configures the comparator output on Port 3. It is located in the expanded register file at Bank F, location 00.

PCON (0F) 00H

D7	D6	D5	D4	D3	D2	D1	D0
----	----	----	----	----	----	----	----

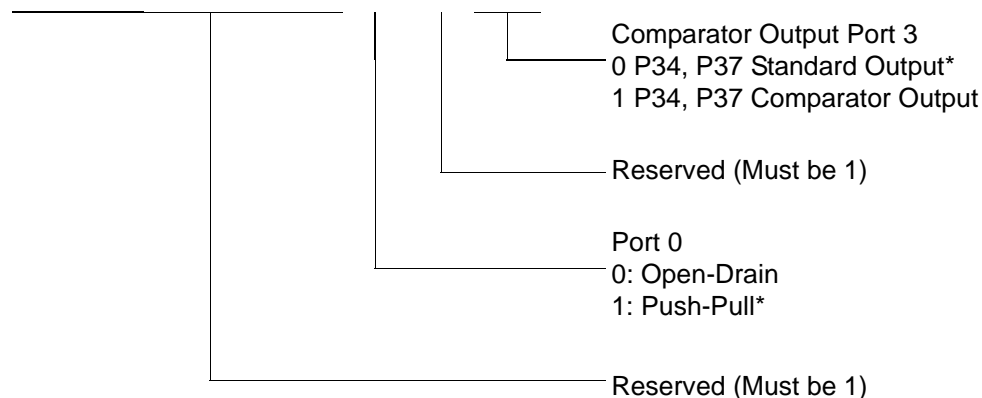

\* Default setting after reset

**Figure 29. Port Configuration Register (PCON) (Write Only)**

### Comparator Output Port 3 (D0)

Bit 0 controls the comparator used in Port 3. A 1 in this location brings the comparator outputs to P34 and P37, and a 0 releases the Port to its standard I/O configuration.

### Port 0 Output Mode (D2)

Bit 2 controls the output mode of port 0. A 1 in this location sets the output to push-pull, and a 0 sets the output to open-drain.





## Stop-Mode Recovery

### Stop-Mode Recovery Register (SMR)

This register selects the clock divide value and determines the mode of Stop Mode Recovery (Figure 30). All bits are write only except bit 7, which is read only. Bit 7 is a flag bit that is hardware set on the condition of Stop recovery and reset by a power-on cycle. Bit 6 controls whether a low level or a high level at the XOR-gate input (Figure 32 on page 53) is required from the recovery source. Bit 5 controls the reset delay after recovery. Bits D2, D3, and D4 of the SMR register specify the source of the Stop-Mode Recovery signal. Bit D0 determines if SCLK/TCLK are divided by 16 or not. The SMR is located in Bank F of the Expanded Register File at address 0Bh.

SMR (0F) 0BH

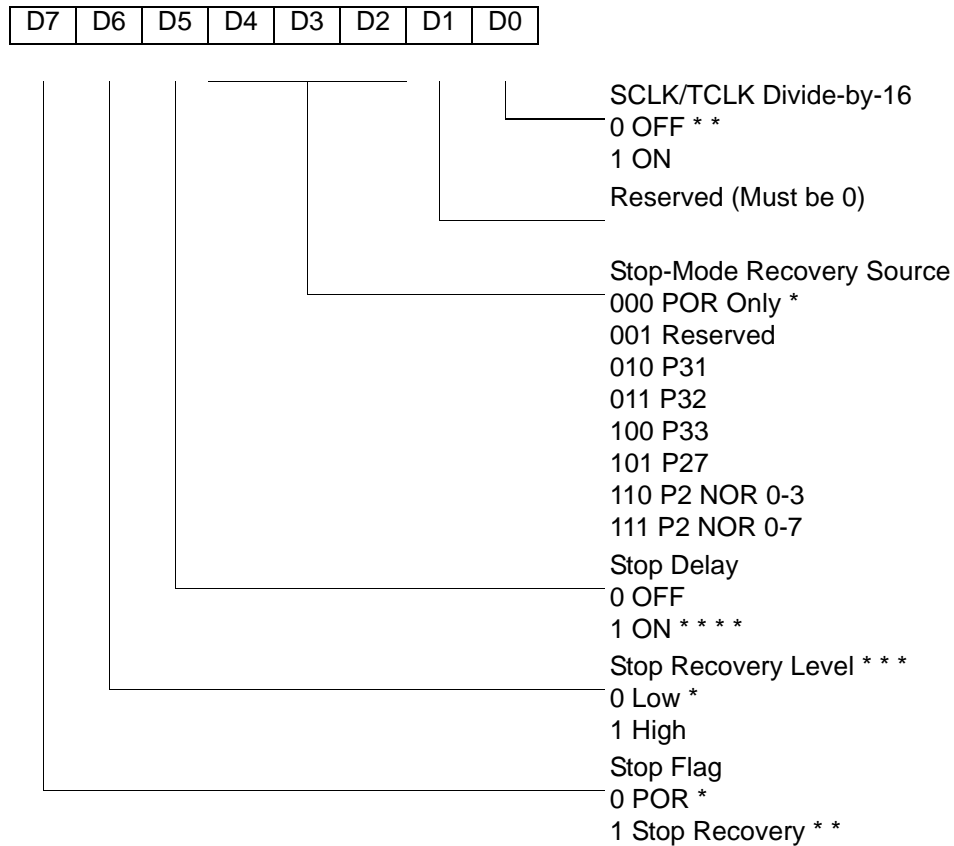

- \* Default after Power On Reset or Watch-Dog Reset
- \*\* Default setting after Reset and Stop Mode Recovery
- \*\*\* At the XOR gate input
- \*\*\*\* Default setting after reset. Must be 1 if using a crystal or resonator clock source.

**Figure 30. Stop Mode Recovery Register**

**SCLK/TCLK Divide-by-16 Select (D0)**

D0 of the SMR controls a divide-by-16 prescaler of SCLK/TCLK (Figure 31). This control selectively reduces device power consumption during normal processor execution (SCLK control) and/or Halt Mode (where TCLK sources interrupt logic). After Stop-Mode Recovery, this bit is set to 0.

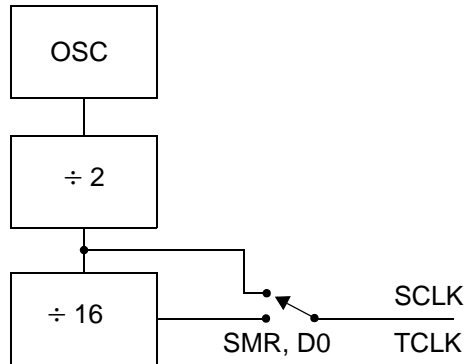

Figure 31. SCLK Circuit

### Stop-Mode Recovery Register 2—SMR2(0F)0DH

Table 17 lists and describes the fields for this register.

Table 17. SMR2(F)0DH: Stop Mode Recovery Register 2\*

Field	Bit Position	Value	Description	
Reserved	7-----	0	Reserved (Must be 0)	
Recovery Level	-6-----	W	0 <sup>†</sup>	Low
			1	High
Reserved	--5-----	0	Reserved (Must be 0)	
Source	---432--	W	000 <sup>†</sup>	A. POR Only
			001	B. NAND of P23–P20
			010	C. NAND of P27–P20
			011	D. NOR of P33–P31
			100	E. NAND of P33–P31
			101	F. NOR of P33–P31, P00, P07
			110	G. NAND of P33–P31, P00, P07
			111	H. NAND of P33–P31, P22–P20
Reserved	-----10	00	Reserved (Must be 0)	

**Notes:**

\* Port pins configured as outputs are ignored as an SMR recovery source.

<sup>†</sup> Indicates the value at Power-On Reset

### Stop-Mode Recovery Source (D2, D3, and D4)

These three bits of the SMR specify the wake-up source of the Stop recovery (Figure 32 and Table 18).

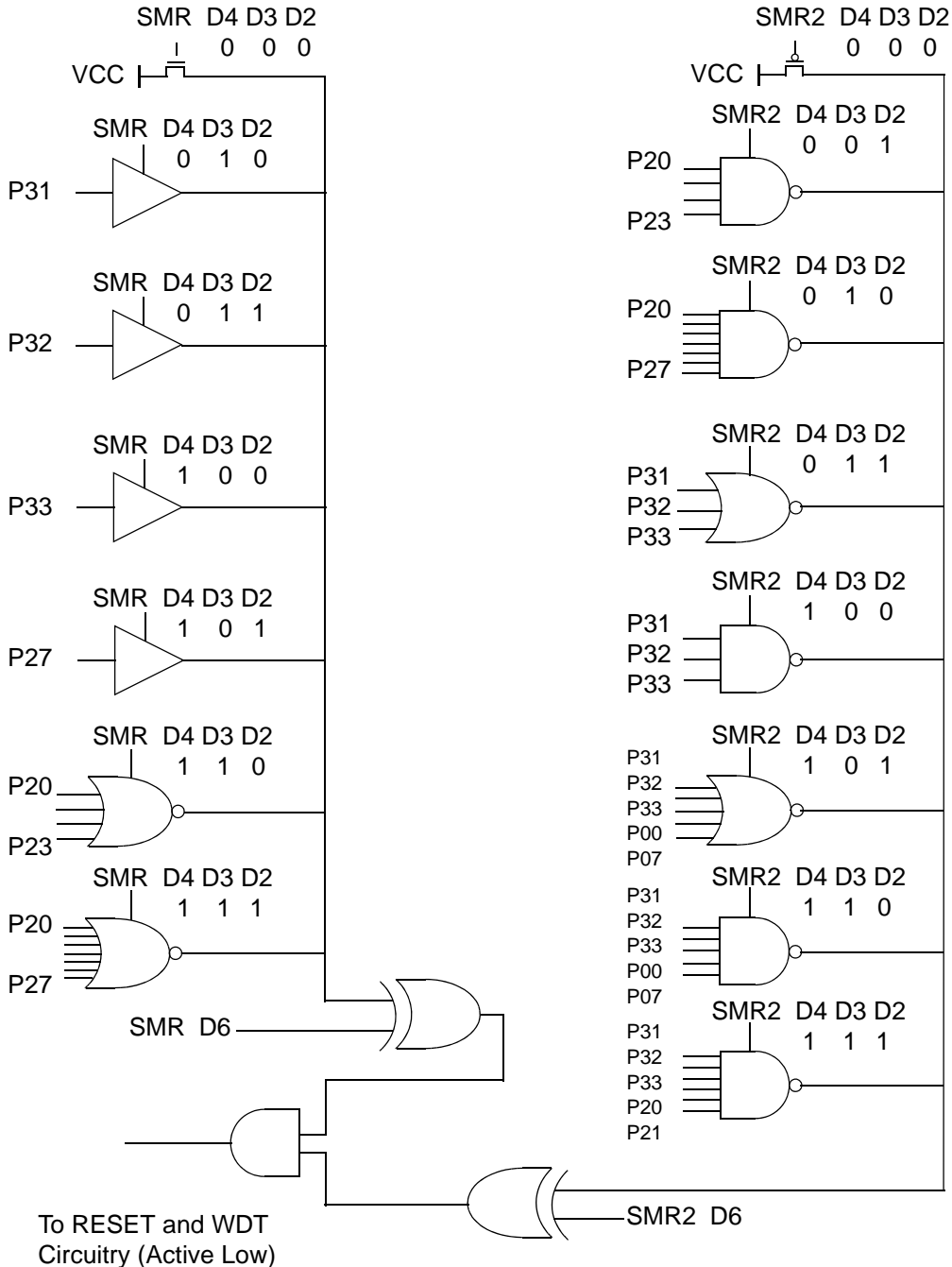

Figure 32. Stop Mode Recovery Source

**Table 18. Stop Mode Recovery Source**

SMR:432			Operation
D4	D3	D2	Description of Action
0	0	0	POR and/or external reset recovery
0	0	1	Reserved
0	1	0	P31 transition
0	1	1	P32 transition
1	0	0	P33 transition
1	0	1	P27 transition
1	1	0	Logical NOR of P20 through P23
1	1	1	Logical NOR of P20 through P27

- **Note:** Any Port 2 bit defined as an output drives the corresponding input to the default state. This condition allows the remaining inputs to control the AND/OR function. Refer to SMR2 register on page 55 for other recover sources.

#### Stop Mode Recovery Delay Select (D5)

This bit, if Low, disables the  $T_{POR}$  delay after Stop Mode Recovery. The default configuration of this bit is 1. If the “fast” wake up is selected, the Stop Mode Recovery source must be kept active for at least 10  $T_{pC}$ .

- **Note:** This bit must be set to 1 if using a crystal or resonator clock source. The  $T_{POR}$  delay allows the clock source to stabilize before executing instructions.

#### Stop Mode Recovery Edge Select (D6)

A 1 in this bit position indicates that a High level on any one of the recovery sources wakes the Crimzon™ ZLR16300 from Stop Mode. A 0 indicates Low level recovery. The default is 0 on POR.

#### Cold or Warm Start (D7)

This bit is read only. It is set to 1 when the device is recovered from Stop Mode. The bit is set to 0 when the device reset is other than Stop Mode Recovery (SMR).



**Stop Mode Recovery Register 2 (SMR2)**

This register determines the mode of Stop Mode Recovery for SMR2 (Figure 33).

SMR2 (0F) DH

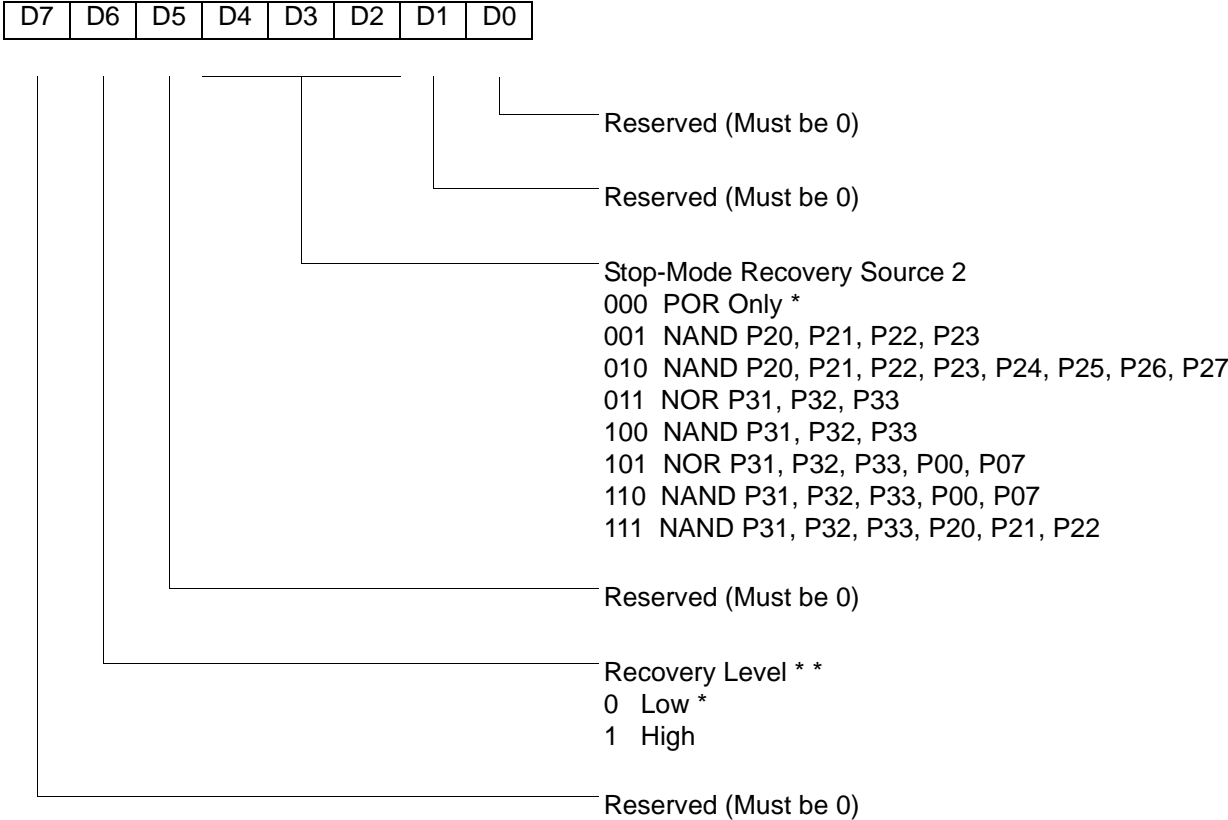

Note: If used in conjunction with SMR, either of the two specified events causes a Stop-Mode Recovery.

\* Default setting after reset

\*\* At the XOR gate input

**Figure 33. Stop Mode Recovery Register 2 ((0F) DH:D2–D4, D6 Write Only)**

If SMR2 is used in conjunction with SMR, either of the specified events causes a Stop Mode Recovery.

► **Note:** Port pins configured as outputs are ignored as an SMR or SMR2 recovery source. For example, if the NAND or P23–P20 is selected as the recovery source and P20 is configured as an output, the remaining SMR pins (P23–P21) form the NAND equation.



## Watchdog Timer Mode

### Watch-Dog Timer Mode Register (WDTMR)

The Watch-Dog Timer (WDT) is a retriggerable one-shot timer that resets the Z8® if it reaches its terminal count. The WDT must initially be enabled by executing the WDT instruction. On subsequent executions of the WDT instruction, the WDT is refreshed. The WDT circuit is driven by an on-board RC-oscillator. The WDT instruction affects the Zero (Z), Sign (S), and Overflow (V) flags.

The POR clock source the internal RC-oscillator. Bits 0 and 1 of the WDT register control a tap circuit that determines the minimum timeout period. Bit 2 determines whether the WDT is active during HALT, and Bit 3 determines WDT activity during STOP. Bits 4 through 7 are reserved (Figure 34). This register is accessible only during the first 60 processor cycles (120 XTAL clocks) from the execution of the first instruction after Power-On-Reset, Watch-Dog Reset, or a Stop-Mode Recovery (Figure 33). After this point, the register cannot be modified by any means (intentional or otherwise). The WDTMR cannot be read. The register is located in Bank F of the Expanded Register File at address location 0Fh. It is organized as illustrated in Figure 34.

WDTMR (0F) 0FH

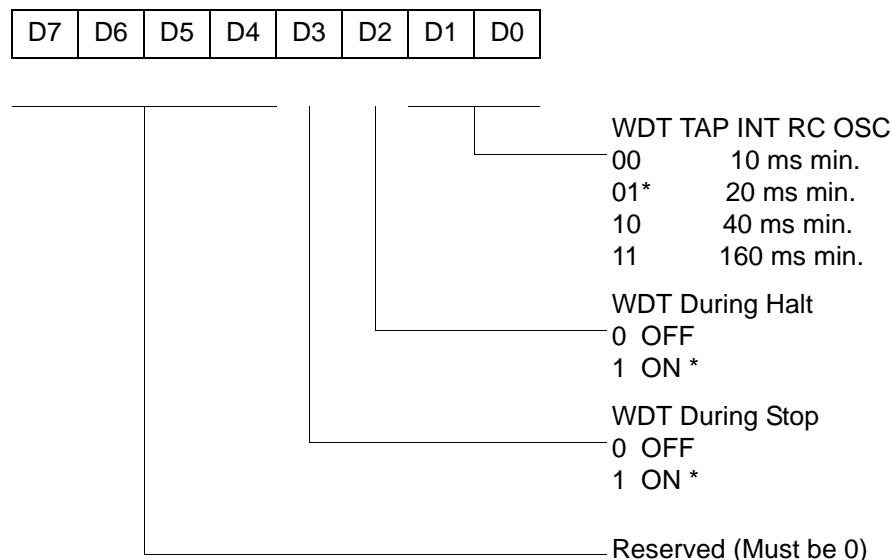

\* Default setting after reset

**Figure 34. Watch-Dog Timer Mode Register (Write Only)**



### WDT Time Select (D0, D1)

This bit selects the WDT time period. It is configured as indicated in [Table 19](#).

**Table 19. Watch-Dog Timer Time Select**

D1	D0	Timeout of Internal RC-Oscillator
0	0	10 ms min.
0	1	20 ms min.
1	0	40 ms min.
1	1	160 ms min.

### WDTMR During Halt (D2)

This bit determines whether or not the WDT is active during Halt Mode. A 1 indicates active during Halt. The default is 1. See [Figure 35](#).



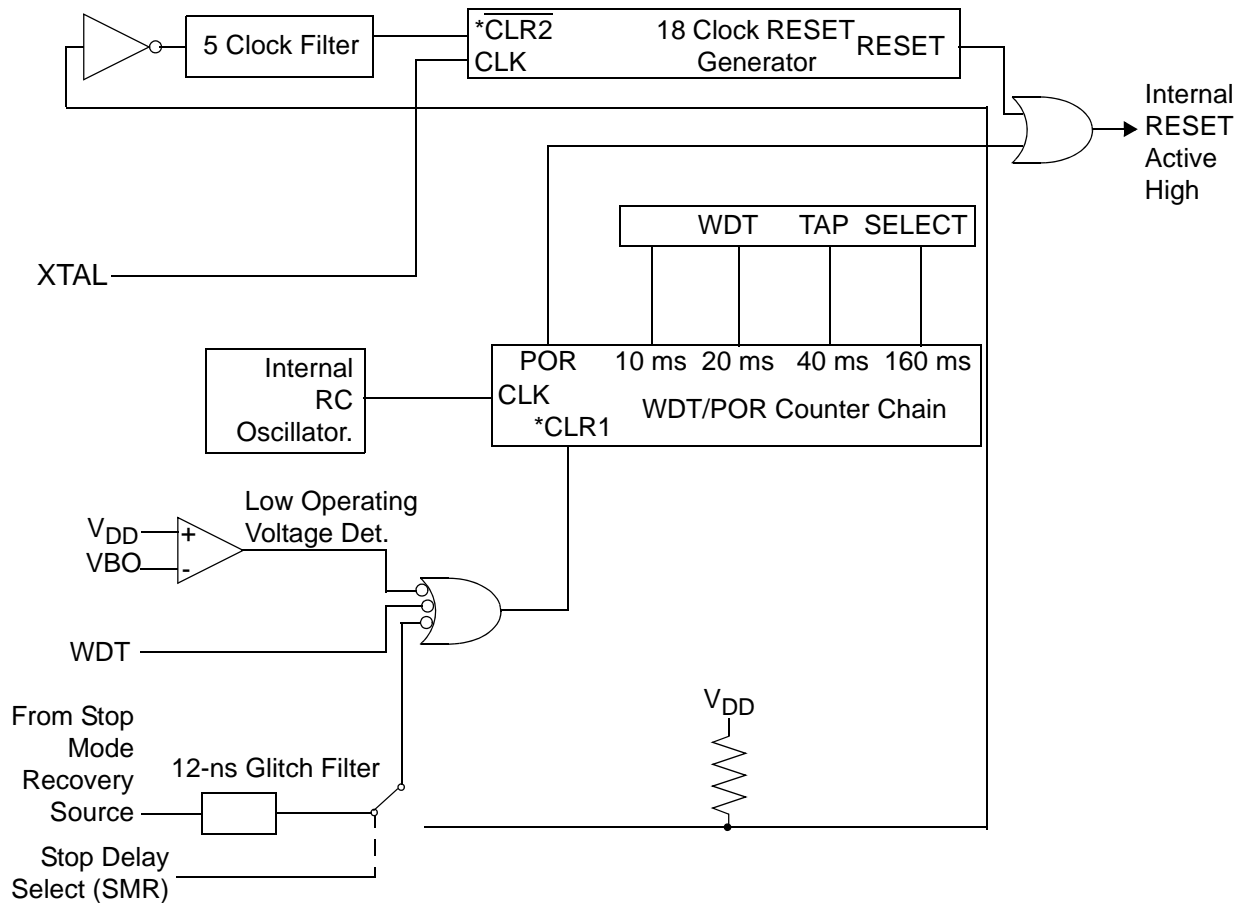

\* CLR1 and  $\overline{\text{CLR2}}$  enable the WDT/POR and 18 Clock Reset timers respectively upon a Low-to-High input translation.

**Figure 35. Resets and WDT**

### WDTMR During Stop (D3)

This bit determines whether or not the WDT is active during Stop Mode. A 1 indicates active during Stop. The default is 1.

### ROM Selectable Options

There are five ROM Selectable Options to choose from based on ROM code requirements. These options are listed in [Table 20](#).



**Table 20. ROM Selectable Options**

Port 00–03 Pull-Ups	On/Off
Port 04–07 Pull-Ups	On/Off
Port 20–27 Pull-Up Port 3 Pull-Ups	On/Off
Port 3 Pull-Ups	On/Off
Watch-Dog Timer at Power-On Reset	On/Off

### Voltage Brown-Out/Standby

An on-chip Voltage Comparator checks that the  $V_{DD}$  is at the required level for correct operation of the device. Reset is globally driven when  $V_{DD}$  falls below  $V_{BO}$ . A small drop in  $V_{DD}$  causes the XTAL1 and XTAL2 circuitry to stop the crystal or resonator clock. If the  $V_{DD}$  is allowed to stay above  $V_{RAM}$ , the RAM content is preserved. When the power level is returned to above  $V_{BO}$ , the device performs a POR and functions normally.

## Low Voltage Detection

### Low-Voltage Detection Register—LVD(0D)0CH

- **Note:** Voltage detection does not work at Stop mode. It must be disabled during Stop mode in order to reduce current.

Field	Bit Position			Description
LVD	765432---			Reserved
	----2	R	1 0*	HVD flag set HVD flag reset
	-----1-	R	1 0*	LVD flag set LVD flag reset
	-----0	R/W	1 0*	Enable VD Disable VD

\*Default after POR



- ▶ **Note:** Do not modify register P01M while checking a low-voltage condition. Switching noise of both ports 0 and 1 together might trigger the LVD flag.

### Voltage Detection and Flags

The Voltage Detection register (LVD, register 0Ch at the expanded register bank 0Dh) offers an option of monitoring the  $V_{CC}$  voltage. The Voltage Detection is enabled when bit 0 of LVD register is set. When Voltage Detection is enabled, the  $V_{CC}$  level is monitored in real time. The flags in the LVD register valid 20uS after Voltage Detection is enabled. The HVD flag (bit 2 of the LVD register) is set only if  $V_{CC}$  is lower than the  $V_{HVD}$ . When Voltage Detection is enabled, the LVD flag also triggers IRQ5. The IRQ bit 5 latches the low voltage condition until it is cleared by instructions or reset. The IRQ5 interrupt is served if it is enabled in the IMR register. Otherwise, bit 5 of IRQ register is latched as a flag only.

- ▶ **Note:** If it is necessary to receive an LVD interrupt upon power-up at an operating voltage lower than the low battery detect threshold, enable interrupts using the Enable Interrupt instruction (EI) prior to enabling the voltage detection.

## Expanded Register File Control Registers (0D)

The expanded register file control registers (0D) are depicted in [Figures 36 through Figure 40](#).



CTR0 (0D) 00H

D7	D6	D5	D4	D3	D2	D1	D0
----	----	----	----	----	----	----	----

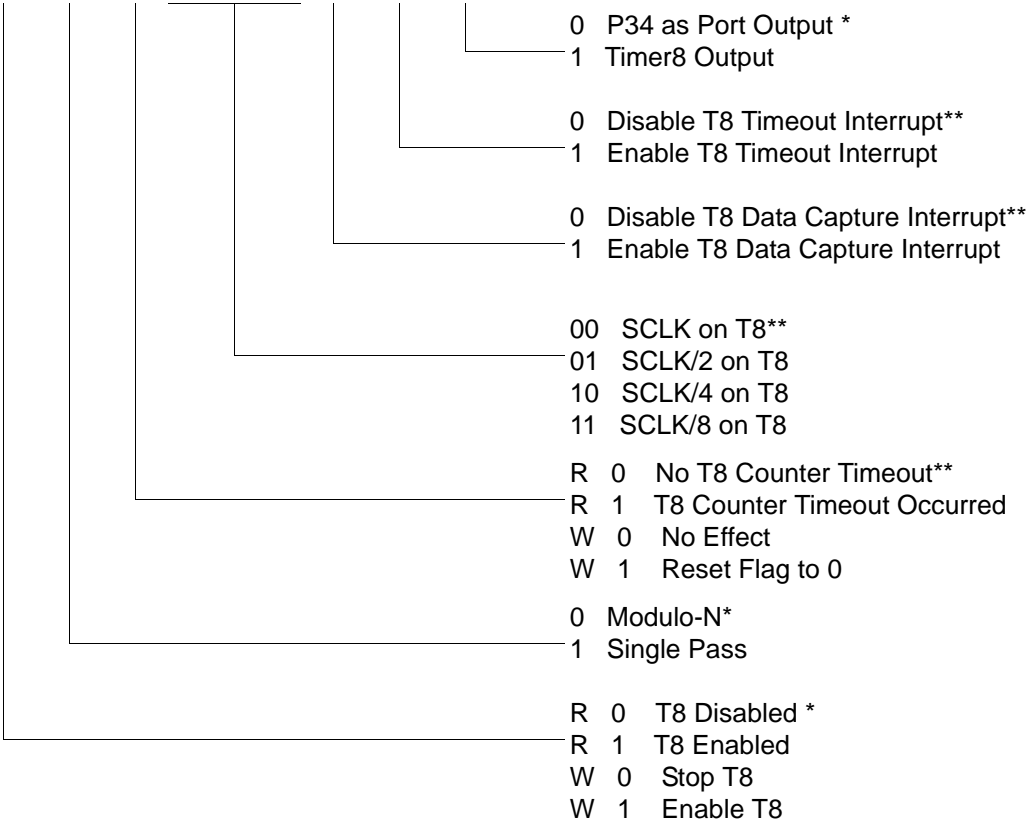

\* Default setting after reset.  
 \*\* Default setting after Reset. Not reset with a Stop Mode recovery

Figure 36. TC8 Control Register ((0D) 00H: Read/Write Except Where Noted)



CTR1 (0D) 01H

D7	D6	D5	D4	D3	D2	D1	D0
----	----	----	----	----	----	----	----

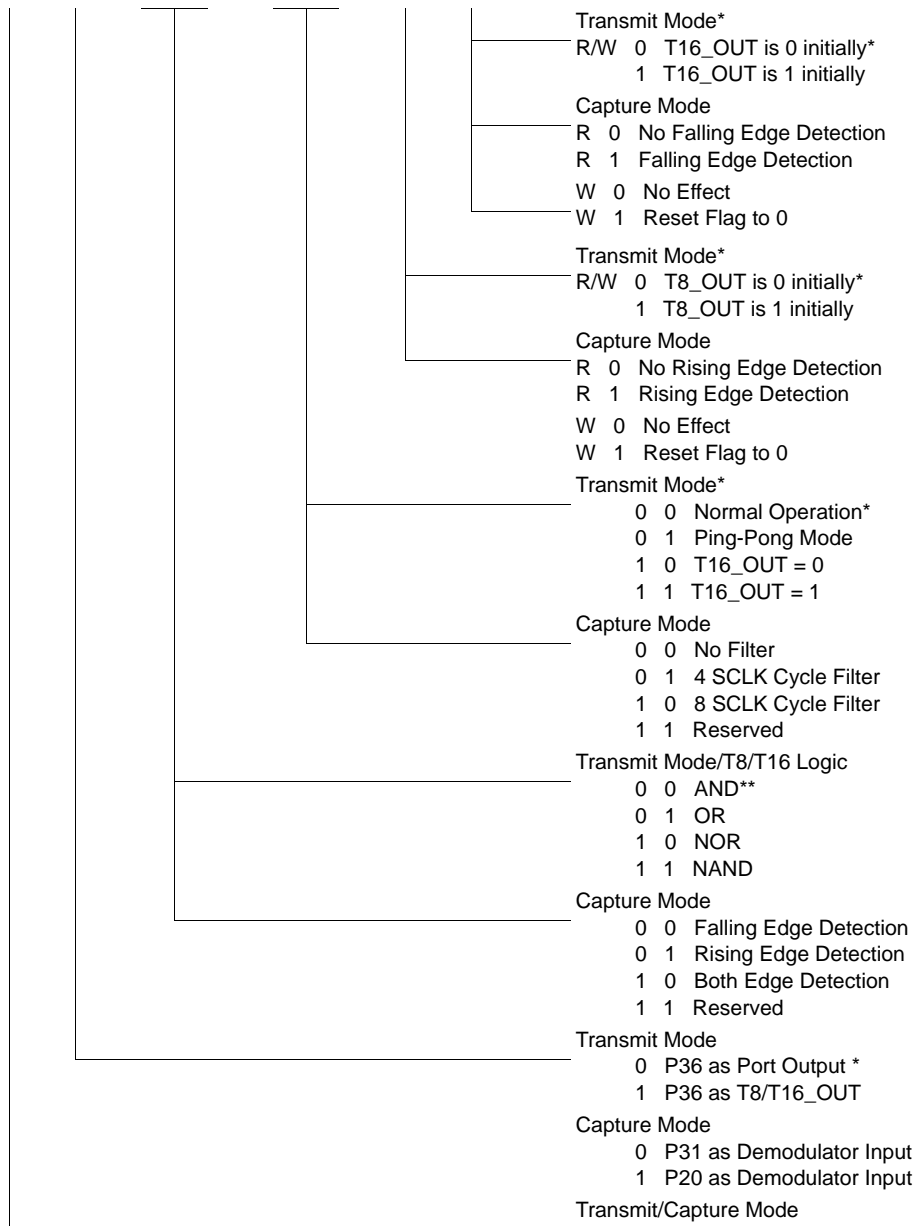

\* Default setting after reset.

\*\* Default setting after Reset. Not reset with a Stop Mode recovery.

Figure 37. T8 and T16 Common Control Functions ((0D) 01H: Read/Write)



- **Notes:** Take care in differentiating the Transmit Mode from Capture Mode. Depending on which of these two modes is operating, the CTR1 bit has different functions.

Changing from one mode to another cannot be performed without disabling the counter/timers.

CTR2 (0D) 02H

D7	D6	D5	D4	D3	D2	D1	D0
----	----	----	----	----	----	----	----

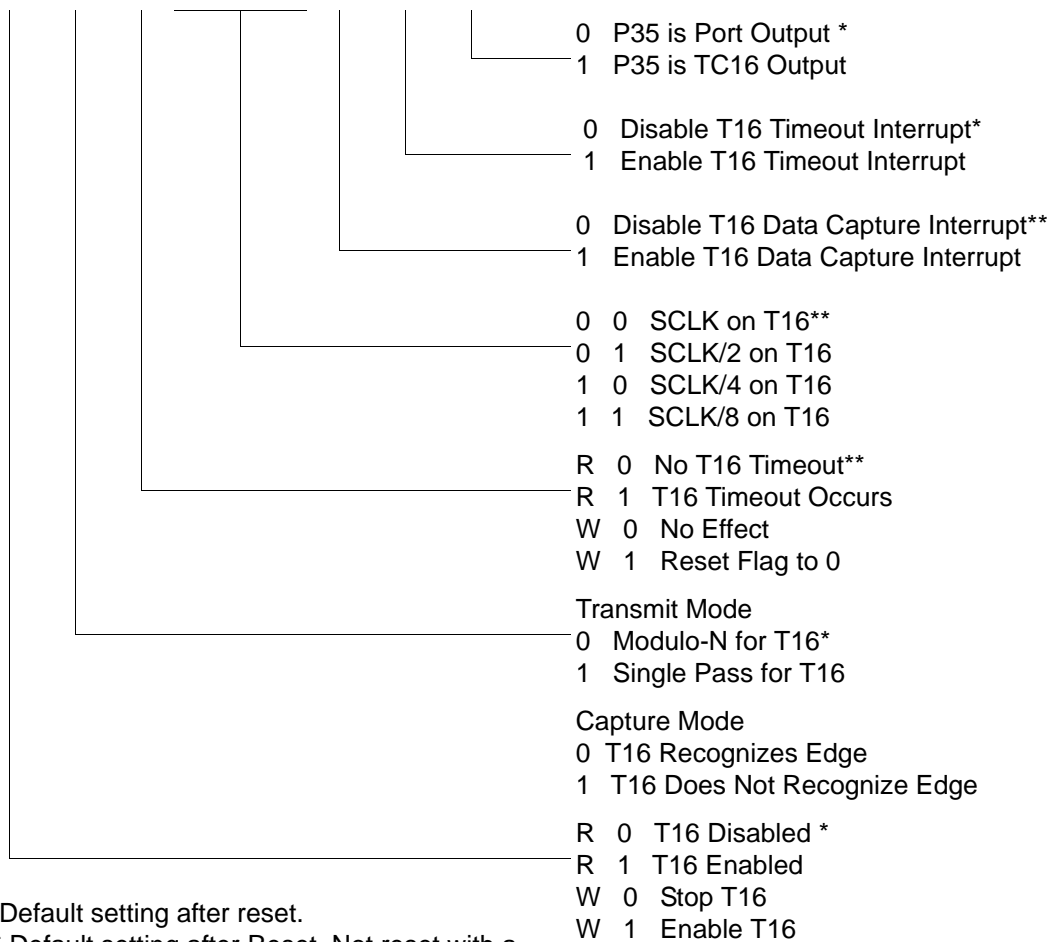

\* Default setting after reset.  
 \*\* Default setting after Reset. Not reset with a Stop Mode recovery.

Figure 38. T16 Control Register ((0D) 02H: Read/Write Except Where Noted)



CTR3 (0D) 03H

D7	D6	D5	D4	D3	D2	D1	D0
----	----	----	----	----	----	----	----

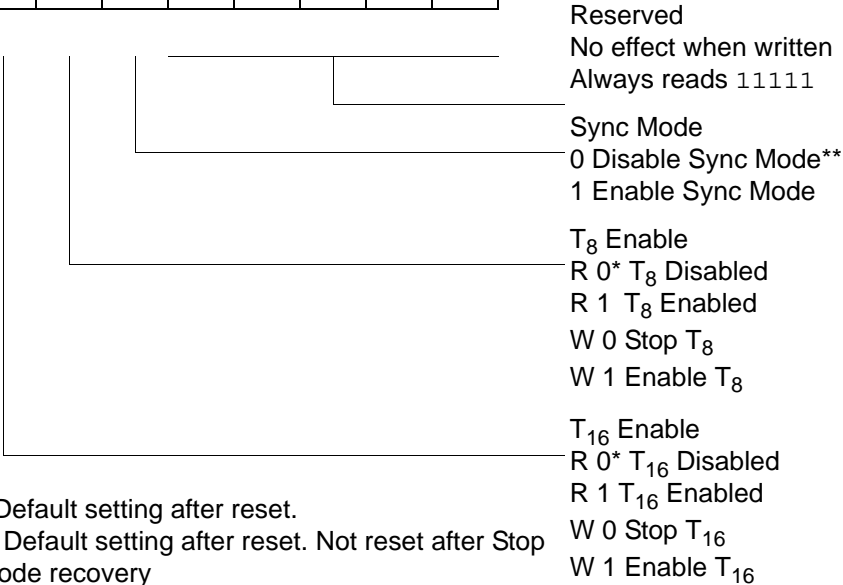

Figure 39. T8/T16 control Register (0D) 03H: Read/Write (Except Where Noted)

► **Note:** If Sync Mode is enabled, the first pulse of T8 (carrier) is always synchronized with T16 (demodulated signal). It can always provide a full carrier pulse.



LVD (0D) 0CH

D7	D6	D5	D4	D3	D2	D1	D0
----	----	----	----	----	----	----	----

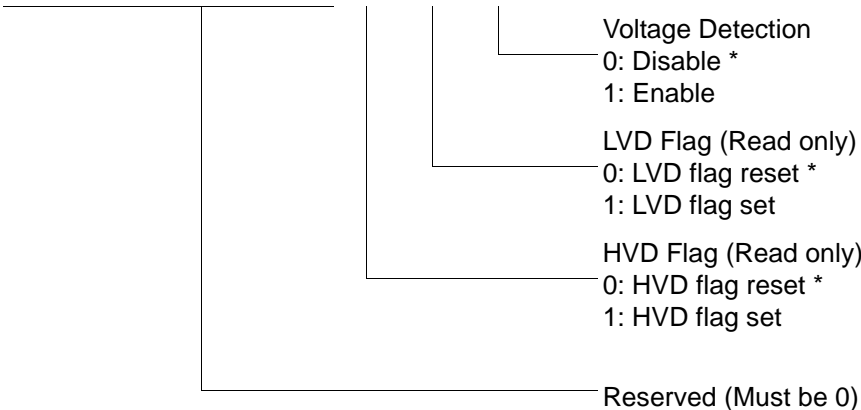

\* Default setting after reset.

Figure 40. Voltage Detection Register

## Expanded Register File Control Registers (0F)

The expanded register file control registers (0F) are depicted in [Figures 41 through Figure 54](#).





PCON (0F) 00H

D7	D6	D5	D4	D3	D2	D1	D0
----	----	----	----	----	----	----	----

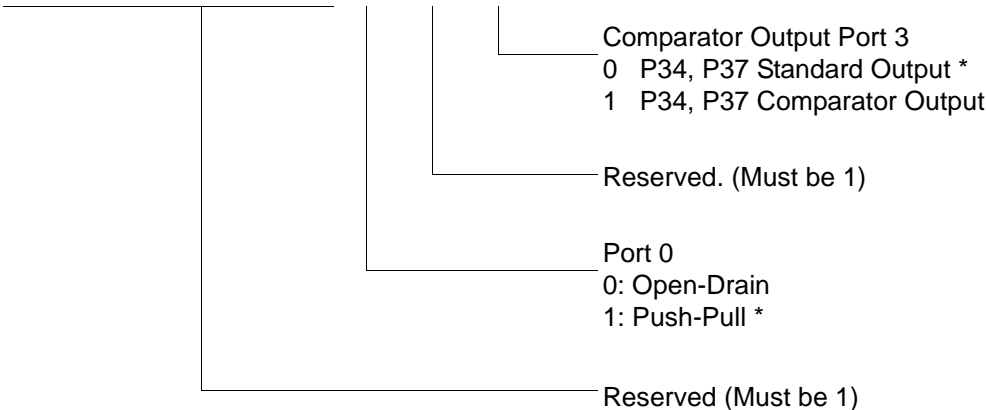

\* Default setting after reset

Figure 41. Port Configuration Register (PCON) ((0F)00H: Write Only)



SMR (0F) 0BH

D7	D6	D5	D4	D3	D2	D1	D0
----	----	----	----	----	----	----	----

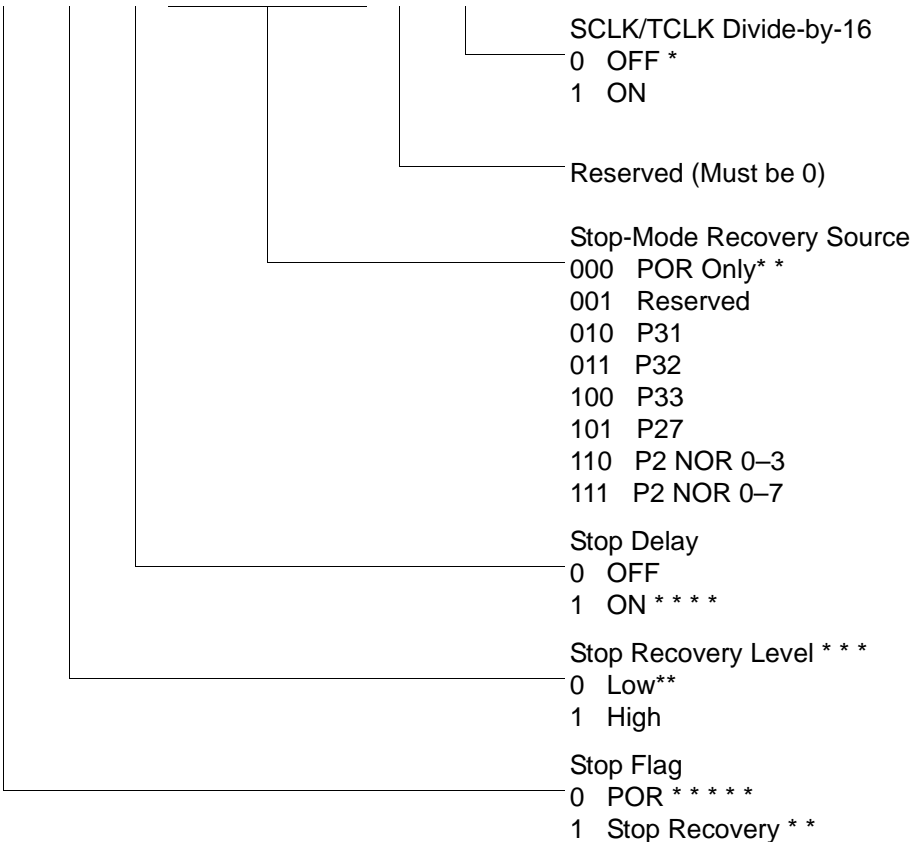

\* Default setting after Reset  
 \* \* Set after STOP Mode Recovery  
 \* \* \* At the XOR gate input  
 \* \* \* \* Default setting after reset. Must be 1 if using a crystal or resonator clock source.  
 Not reset with a Stop Mode recovery.  
 \* \* \* \* \* Default setting after Power On Reset

Figure 42. Stop Mode Recovery Register ((0F) 0BH: D6–D0=Write Only, D7=Read Only)

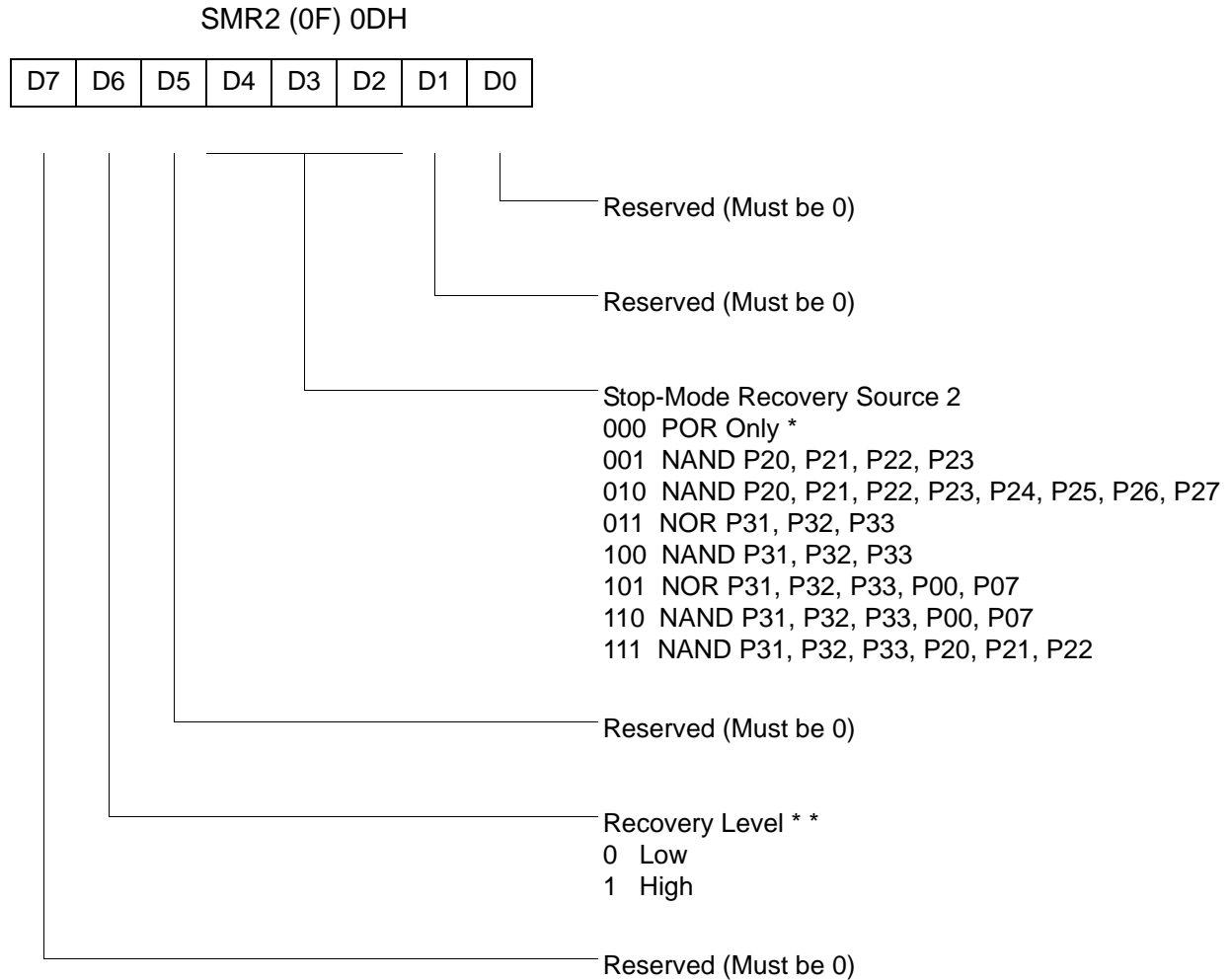

Note: If used in conjunction with SMR, either of the two specified events causes a Stop-Mode Recovery.

\* Default setting after reset. Not reset with a Stop Mode recovery.

\*\* At the XOR gate input

**Figure 43. Stop Mode Recovery Register 2 ((0F) 0DH: D2–D4, D6 Write Only)**

WDTMR (0F) 0FH

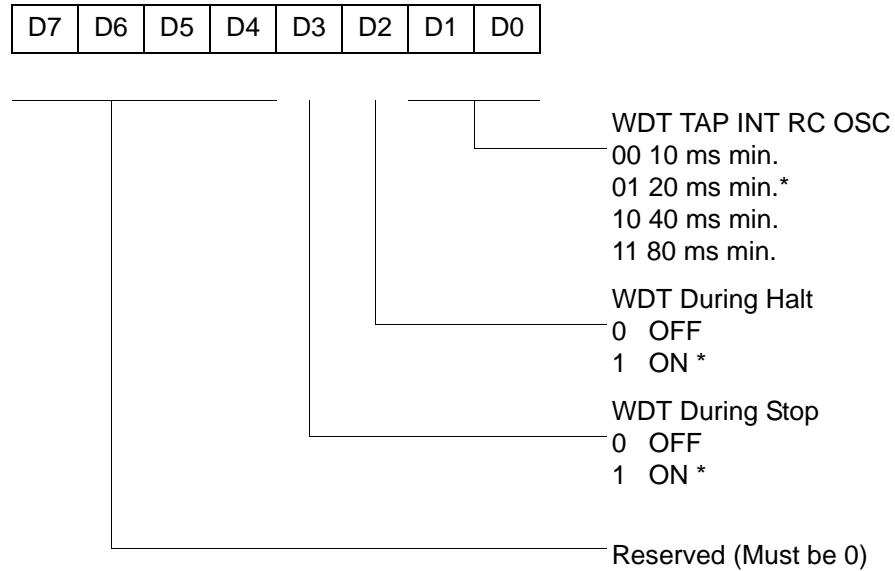

\* Default setting after reset. Not reset with a Stop Mode recovery.

Figure 44. Watch-Dog Timer Register ((0F) 0FH: Write Only)

## Standard Control Registers

R246 P2M (F6H)

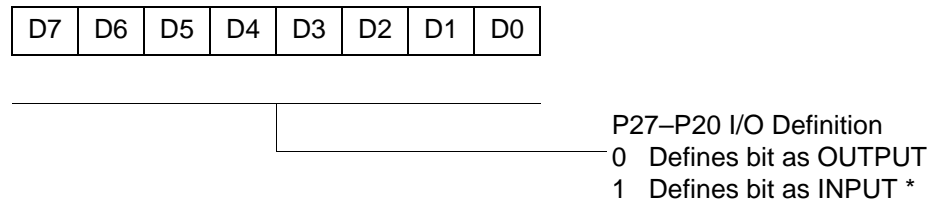

\* Default setting after reset. Not reset with a Stop Mode recovery.

Figure 45. Port 2 Mode Register (F6H: Write Only)



R247 P3M (F7H)

D7	D6	D5	D4	D3	D2	D1	D0
----	----	----	----	----	----	----	----

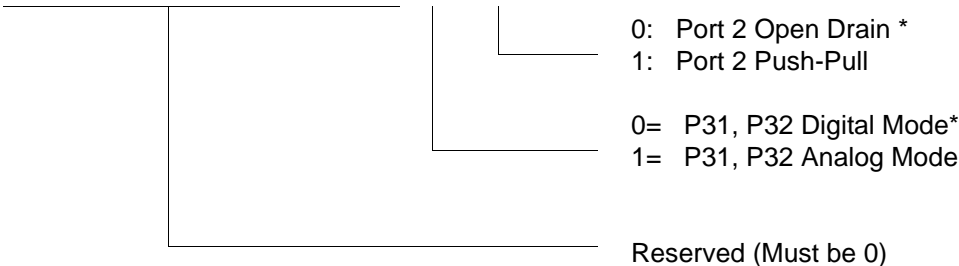

\* Default setting after reset. Not reset with a Stop Mode recovery.

Figure 46. Port 3 Mode Register (F7H: Write Only)



R248 P01M (F8H)

D7	D6	D5	D4	D3	D2	D1	D0
----	----	----	----	----	----	----	----

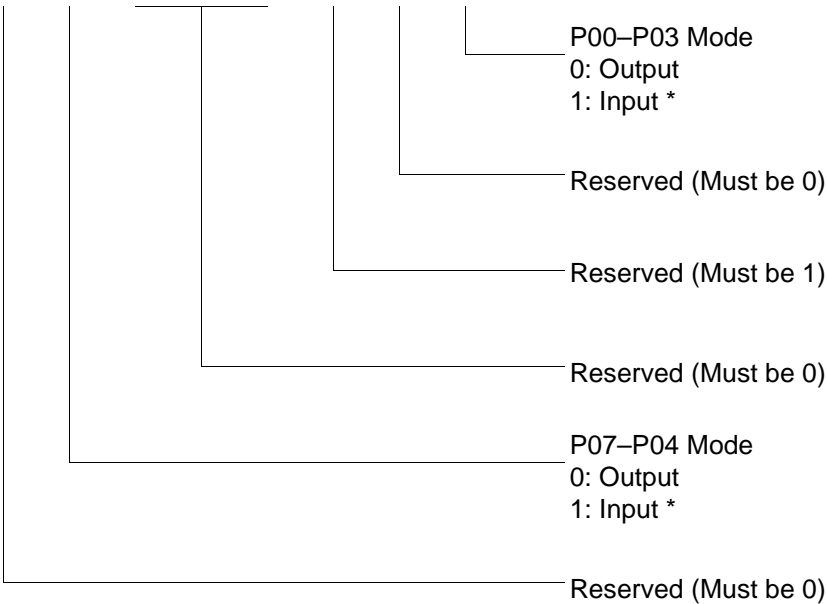

\* Default setting after reset; only P00, P01 and P07 are available on 20-pin configurations.

Figure 47. Port 0 Register (F8H: Write Only)



R249 IPR (F9H)

D7	D6	D5	D4	D3	D2	D1	D0
----	----	----	----	----	----	----	----

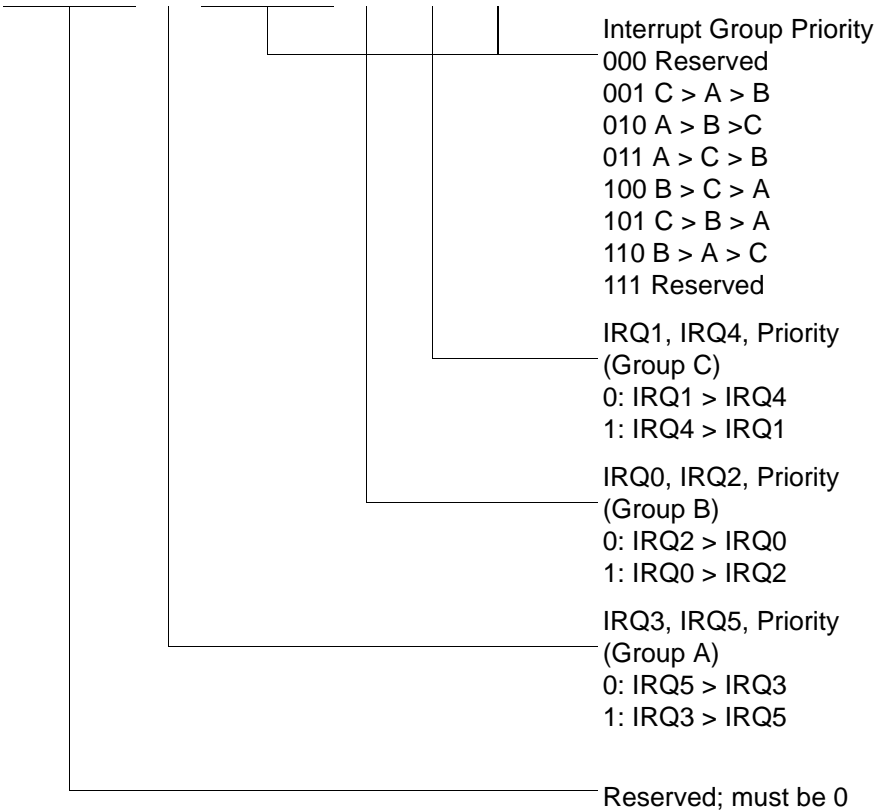

Figure 48. Interrupt Priority Register (F9H: Write Only)



R250 IRQ (FAH)

D7	D6	D5	D4	D3	D2	D1	D0
----	----	----	----	----	----	----	----

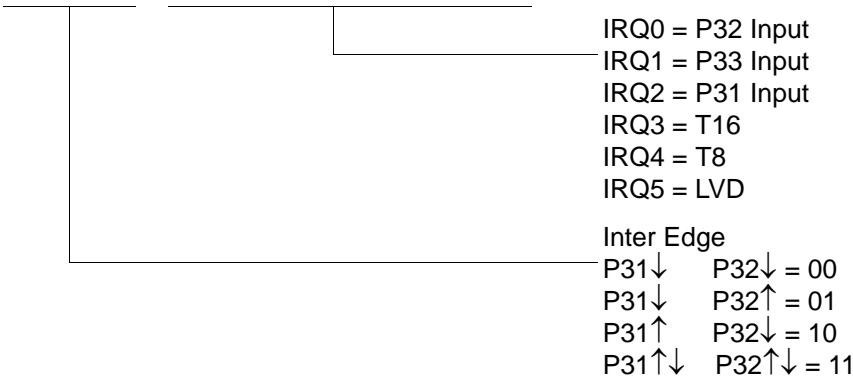
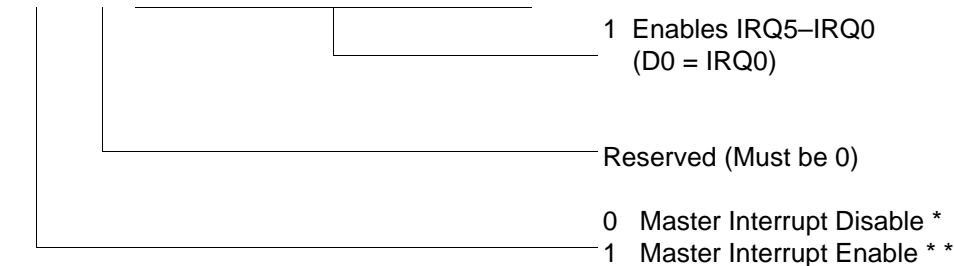

Figure 49. Interrupt Request Register (FAH: Read/Write)

R251 IMR (FBH)

D7	D6	D5	D4	D3	D2	D1	D0
----	----	----	----	----	----	----	----



\* Default setting after reset  
 \*\* Only by using EI, DI instruction; DI is required before changing the IMR register

Figure 50. Interrupt Mask Register (FBH: Read/Write)





R252 Flags (FCH)

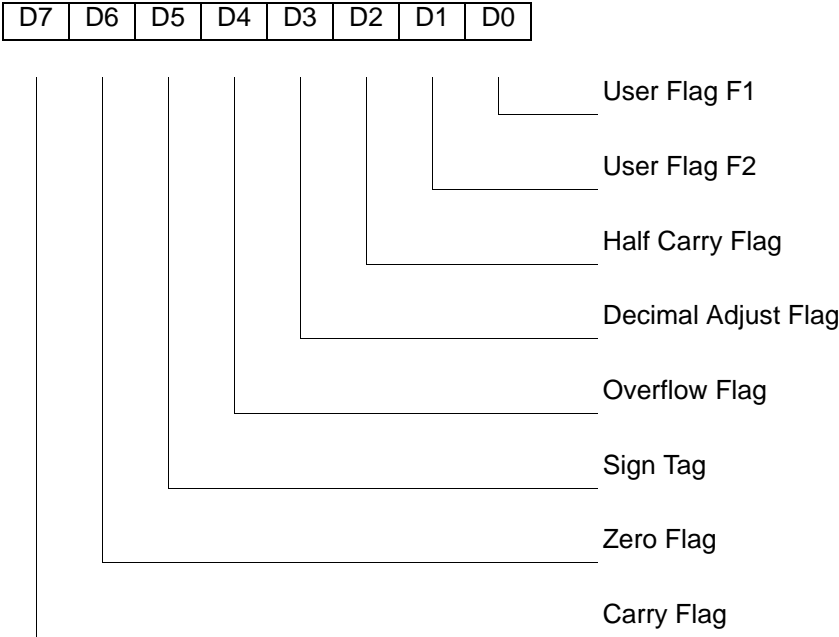
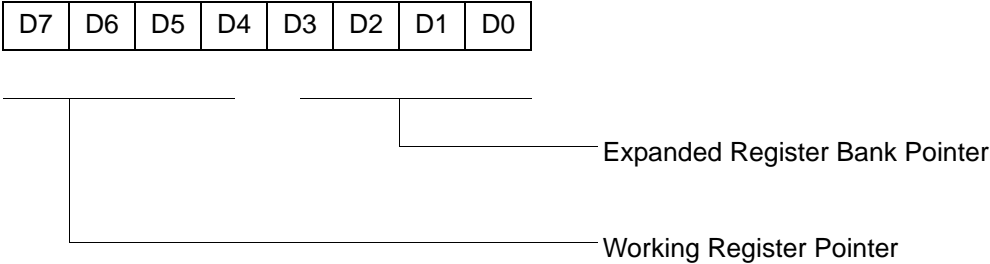

Figure 51. Flag Register (FCH: Read/Write)

R253 RP (FDH)



Default setting after reset = 0000 0000

Figure 52. Register Pointer (FDH: Read/Write)



R254 SPH (FEH)

D7	D6	D5	D4	D3	D2	D1	D0
----	----	----	----	----	----	----	----



Figure 53. Stack Pointer High (FEH: Read/Write)

R255 SPL (FFH)

D7	D6	D5	D4	D3	D2	D1	D0
----	----	----	----	----	----	----	----

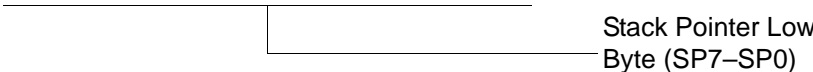
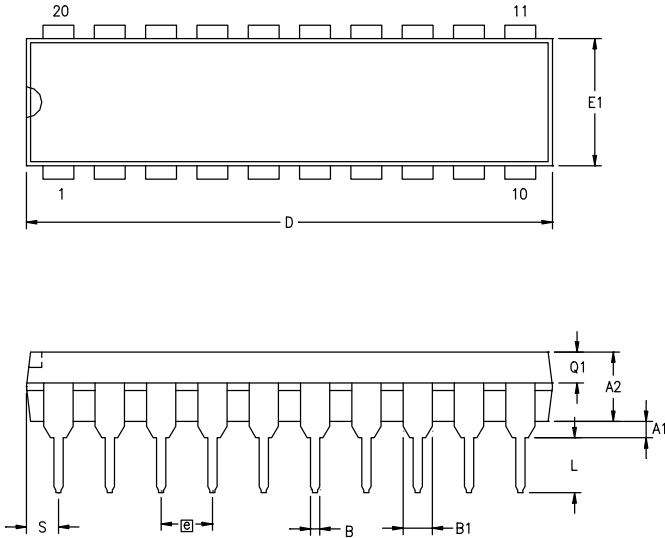

Figure 54. Stack Pointer Low (FFH: Read/Write)

## Package Information

Package information for all device versions of ZGR16300 is depicted in [Figures 55 through Figure 60](#).



SYMBOL	MILLIMETER		INCH	
	MIN	MAX	MIN	MAX
A1	0.38	0.81	.015	.032
A2	3.25	3.68	.128	.145
B	0.41	0.51	.016	.020
B1	1.47	1.57	.058	.062
C	0.20	0.30	.008	.012
D	25.65	26.16	1.010	1.030
E	7.49	8.26	.295	.325
E1	6.10	6.65	.240	.262
[G]	2.54 BSC		.100 BSC	
eA	7.87	9.14	.310	.360
L	3.18	3.43	.125	.135
Q1	1.42	1.65	.056	.065
S	1.52	1.65	.060	.065

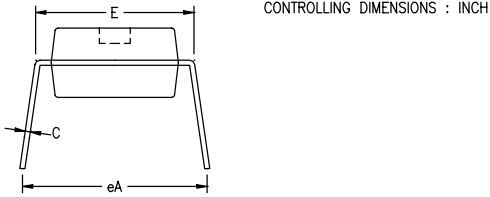
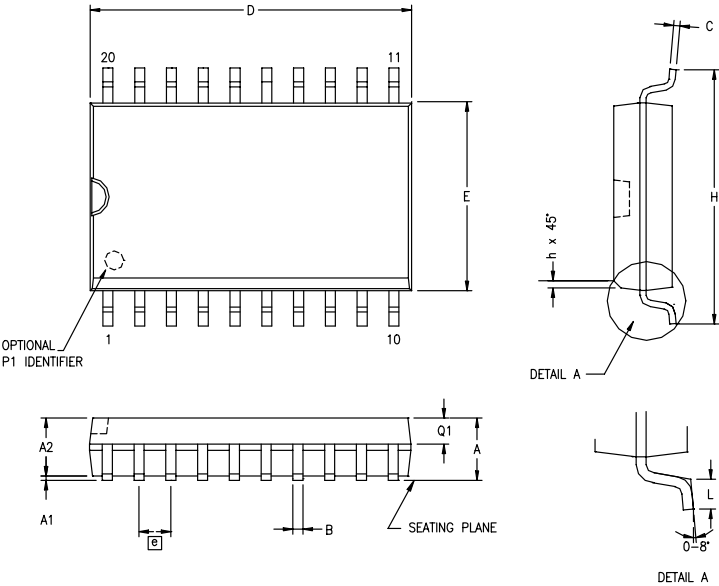

Figure 55. 20-Pin DIP Package Diagram



SYMBOL	MILLIMETER		INCH	
	MIN	MAX	MIN	MAX
A	2.40	2.65	.094	.104
A1	0.10	0.30	.004	.012
A2	2.24	2.44	.088	.096
B	0.36	0.46	.014	.018
C	0.23	0.30	.009	.012
D	12.60	12.95	.496	.510
E	7.40	7.60	.291	.299
[G]	1.27 BSC		.050 BSC	
H	10.00	10.65	.394	.419
h	0.30	0.40	.012	.016
L	0.60	1.00	.024	.039
Q1	0.97	1.07	.038	.042

CONTROLLING DIMENSIONS : MM  
LEADS ARE COPLANAR WITHIN .004 INCH.

Figure 56. 20-Pin SOIC Package Diagram

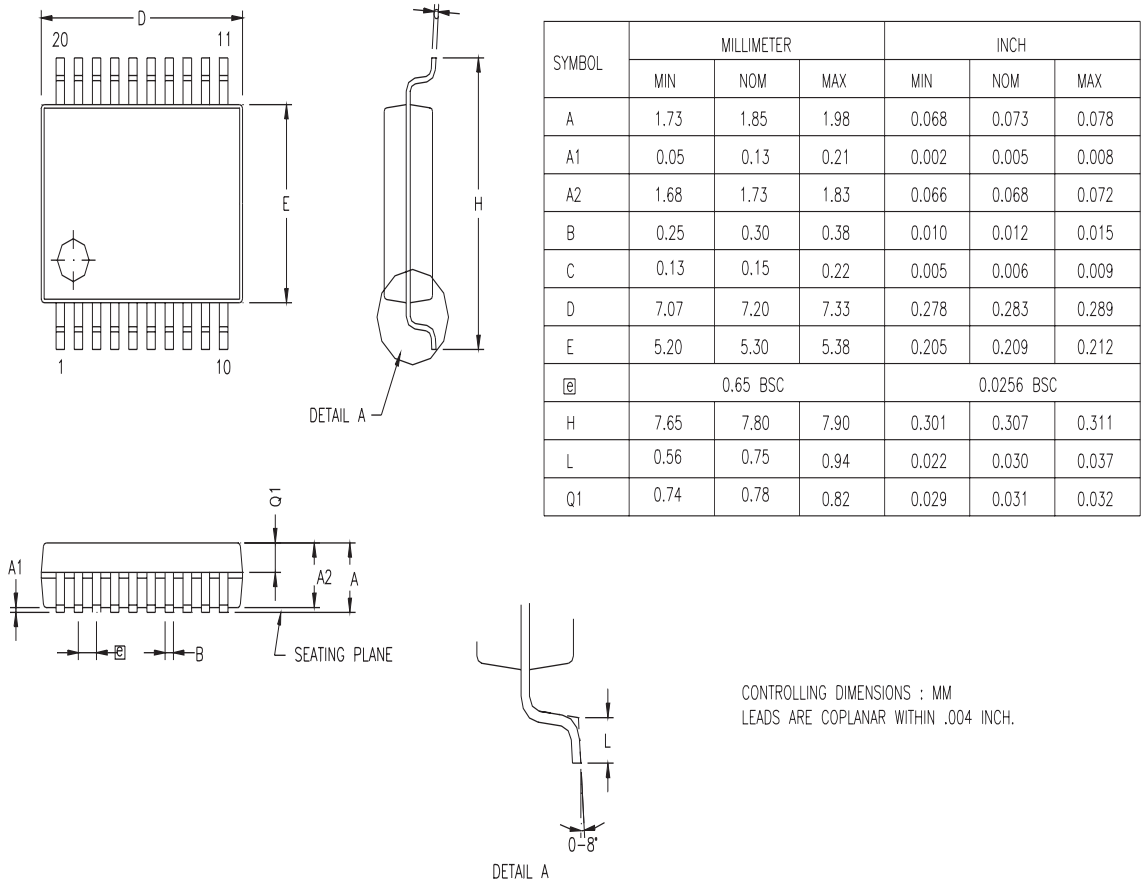
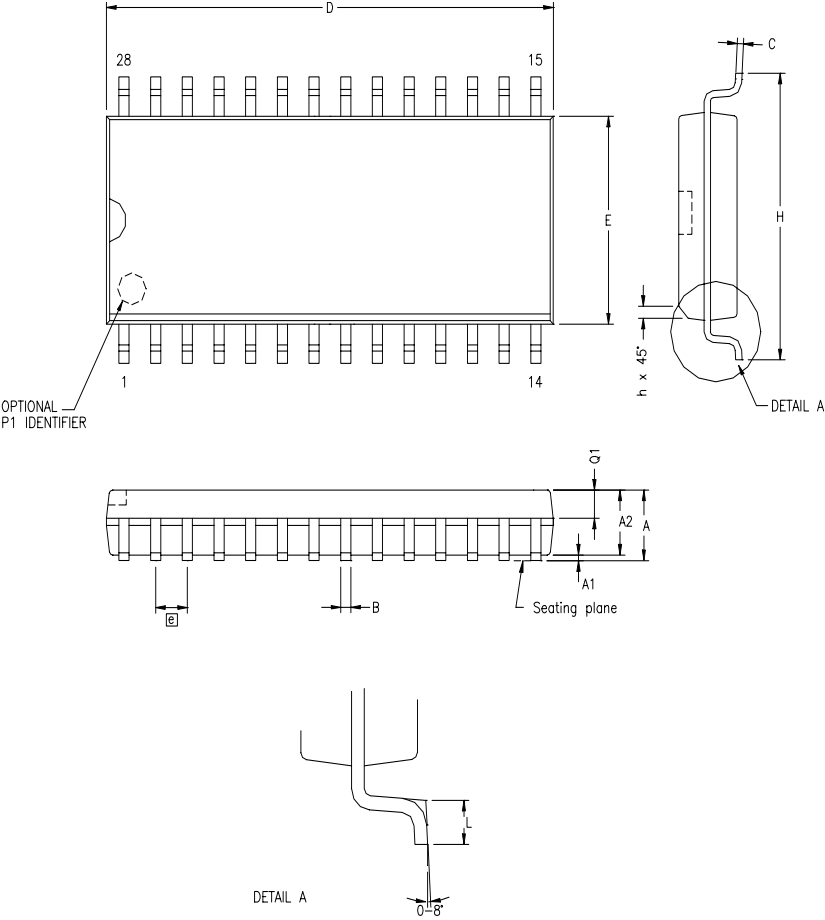

Figure 57. 20-Pin SSOP Package Diagram



SYMBOL	MILLIMETER		INCH	
	MIN	MAX	MIN	MAX
A	2.40	2.64	.094	.104
A1	0.10	0.30	.004	.012
A2	2.24	2.44	.088	.096
B	0.36	0.46	.014	.018
C	0.23	0.30	.009	.012
D	17.78	18.00	.700	.710
E	7.40	7.60	.291	.299
Ⓜ	1.27 BSC		.050 BSC	
H	10.00	10.65	.394	.419
h	0.30	0.71	.012	.028
L	0.61	1.00	.024	.039
Q1	0.97	1.09	.038	.043

CONTROLLING DIMENSIONS : MM  
 LEADS ARE COPLANAR WITHIN .004 INCH.

Figure 58. 28-Pin SOIC Package Diagram

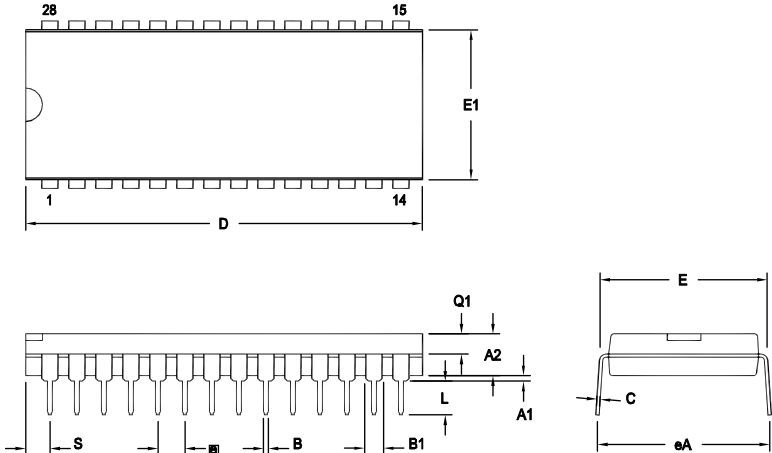

SYMBOL	OPT #	MILLIMETER		INCH	
		MIN	MAX	MIN	MAX
A1		0.38	1.02	.015	.040
A2		3.18	4.19	.125	.165
B		0.38	0.53	.015	.021
B1	01	1.40	1.65	.055	.065
	02	1.14	1.40	.045	.055
C		0.23	0.38	.009	.015
D	01	36.58	37.34	1.440	1.470
	02	35.31	35.94	1.390	1.415
E		15.24	15.75	.600	.620
E1	01	13.59	14.10	.535	.555
	02	12.83	13.08	.505	.515
e		2.54 TYP		.100 BSC	
eA		15.49	16.76	.610	.660
L		3.05	3.81	.120	.150
Q1	01	1.40	1.91	.055	.075
	02	1.40	1.78	.055	.070
S	01	1.52	2.29	.060	.090
	02	1.02	1.52	.040	.060

CONTROLLING DIMENSIONS : INCH

OPTION TABLE	
OPTION #	PACKAGE
01	STANDARD
02	IDF

Note: ZILOG supplies both options for production. Component layout PCB design should cover bigger option 01.

Figure 59. 28-Pin DIP Package Diagram

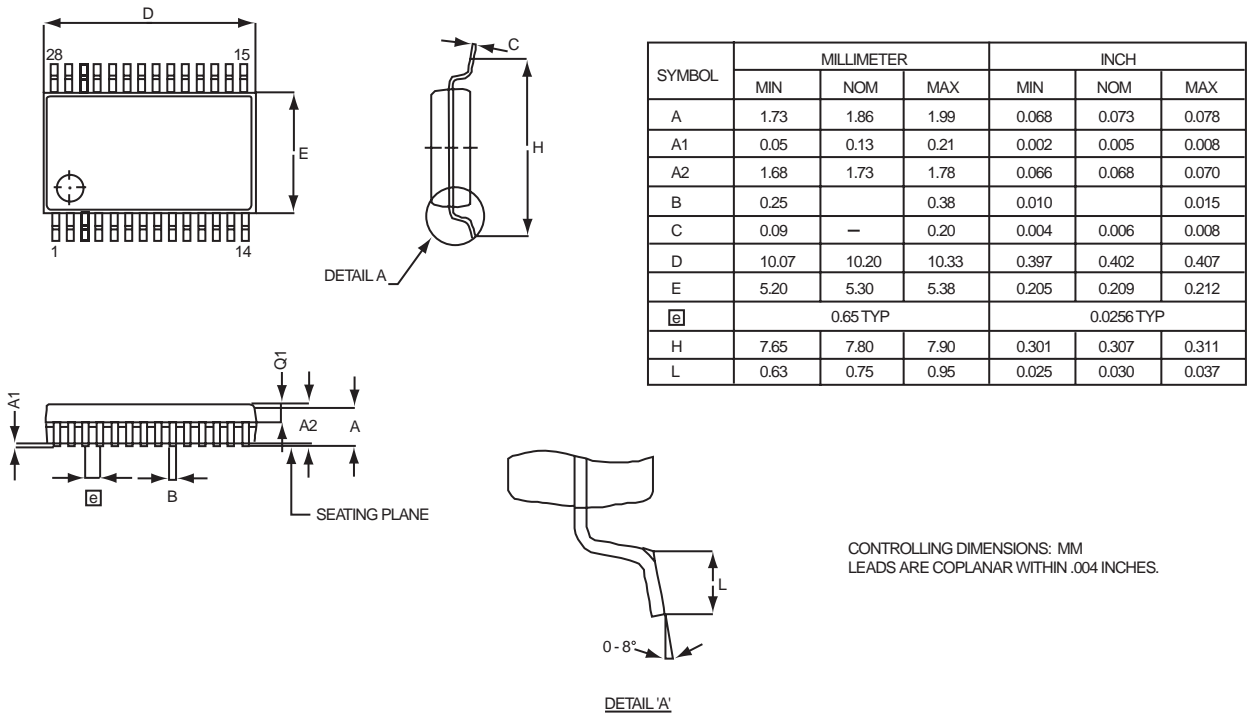

Figure 60. 28-Pin SSOP Package Diagram

► **Note:** Please check with ZiLOG® on the actual bonding diagram and coordinate for chip-on-board assembly.

### Ordering Information

The following table provides ordering information for the ZLR16300 16K, 8K, 4K, 2K, and 1K parts.



Memory Size	Part No.	Description
<b>16K</b>	ZLR16300H2816G	28-pin SSOP 16K ROM
	ZLR16300P2816G	28-pin PDIP 16K ROM
	ZLR16300S2816G	28-pin SOIC 16K ROM
	ZLR16300H2016G	20-pin SSOP 16K ROM
	ZLR16300P2016G	20-pin PDIP 16K ROM
	ZLR16300S2016G	20-pin SOIC 16K ROM
<b>8K</b>	ZLR16300H2808G	28-pin SSOP 8K ROM
	ZLR16300P2808G	28-pin PDIP 8K ROM
	ZLR16300S2808G	28-pin SOIC 8K ROM
	ZLR16300H2008G	20-pin SSOP 8K ROM
	ZLR16300P2008G	20-pin PDIP 8K ROM
	ZLR16300S2008G	20-pin SOIC 8K ROM
<b>4K</b>	ZLR16300H2804G	28-pin SSOP 4K ROM
	ZLR16300P2804G	28-pin PDIP 4K ROM
	ZLR16300S2804G	28-pin SOIC 4K ROM
	ZLR16300H2004G	20-pin SSOP 4K ROM
	ZLR16300P2004G	20-pin PDIP 4K ROM
	ZLR16300S2004G	20-pin SOIC 4K ROM
<b>2K</b>	ZLR16300H2802G	28-pin SSOP 2K ROM
	ZLR16300P2802G	28-pin PDIP 2K ROM
	ZLR16300S2802G	28-pin SOIC 2K ROM
	ZLR16300H2002G	20-pin SSOP 2K ROM
	ZLR16300P2002G	20-pin PDIP 2K ROM
	ZLR16300S2002G	20-pin SOIC 2K ROM
<b>1K</b>	ZLR16300H2801G	28-pin SSOP 1K ROM
	ZLR16300P2801G	28-pin PDIP 1K ROM
	ZLR16300S2801G	28-pin SOIC 1K ROM
	ZLR16300H2001G	20-pin SSOP 1K ROM
	ZLR16300P2001G	20-pin PDIP 1K ROM
	ZLR16300S2001G	20-pin SOIC 1K ROM

ZLP128ICE01ZEM	In-Circuit Emulator
----------------	---------------------

Note: Contact [www.zilog.com](http://www.zilog.com) for the die form.





For fast results, contact your local ZiLOG sales office for assistance in ordering the part desired.

## Part Number Description

ZiLOG part numbers consist of a number of components, as shown in Figure 61. The example part number ZLR16300H2816G is a Crimzon™ masked ROM product in a 28-pin SSOP package, with 16 KB of ROM and built with lead-free solder.

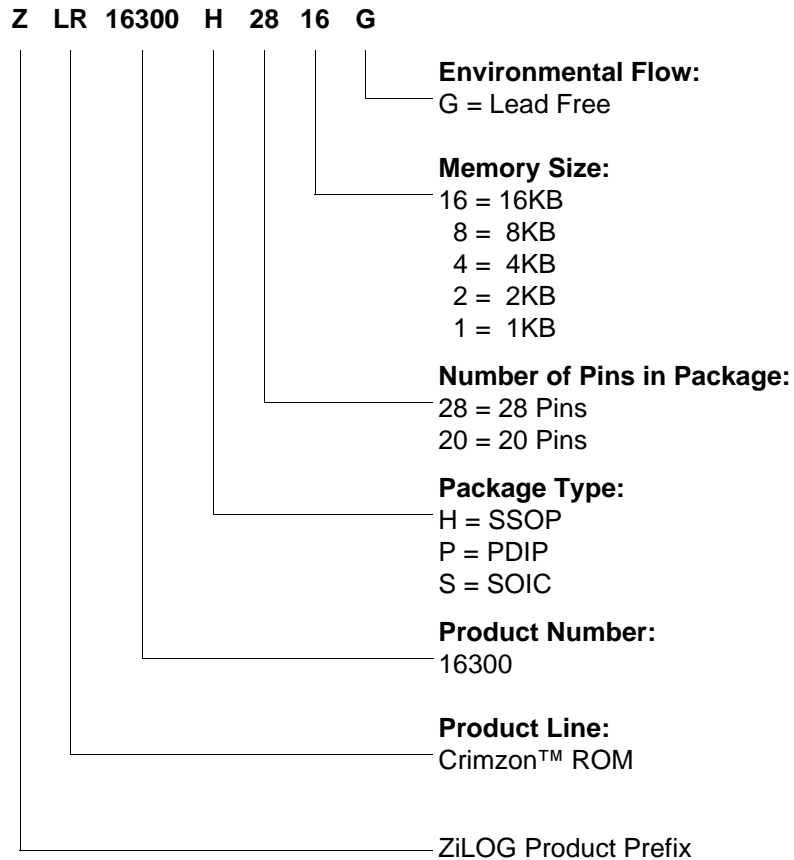

Figure 61. Part Number Description Example



# Index

## Numerics

16-bit counter/timer circuits 40  
20-pin DIP package diagram 76  
20-pin SSOP package diagram 77  
28-pin DIP package diagram 79  
28-pin SOIC package diagram 78  
28-pin SSOP package diagram 80  
8-bit counter/timer circuits 36

## A

absolute maximum ratings 6  
AC  
    characteristics 10  
    timing diagram 10  
address spaces, basic 2  
architecture 2  
    expanded register file 22

## B

basic address spaces 2  
block diagram, ZLR16300 functional 3

## C

capacitance 8  
capture\_INT\_mask 28, 33  
characteristics  
    AC 10  
    DC 8  
clock 47  
comparator inputs/outputs 19  
configuration  
    port 0 14  
    port 2 15  
    port 3 16  
    port 3 counter/timer 18  
counter/timer  
    16-bit circuits 40

8-bit circuits 36  
brown-out voltage/standby 59  
clock 47  
demodulation mode count capture flowchart 38  
demodulation mode flowchart 39  
EPROM selectable options 59  
glitch filter circuitry 34  
halt instruction 48  
input circuit 34  
interrupt block diagram 45  
interrupt types, sources and vectors 46  
oscillator configuration 47  
output circuit 43  
ping-pong mode 42  
port configuration register 49  
resets and WDT 58  
SCLK circuit 52  
stop instruction 48  
stop mode recovery register 51  
stop mode recovery register 2 55  
stop mode recovery source 53  
T16 demodulation mode 41  
T16 transmit mode 40  
T16\_OUT in modulo-N mode 41  
T16\_OUT in single-pass mode 41  
T8 demodulation mode 37  
T8 transmit mode 34  
T8\_OUT in modulo-N mode 37  
T8\_OUT in single-pass mode 37  
transmit mode flowchart 35  
voltage detection and flags 60  
watch-dog timer mode register 56  
watch-dog timer time select 57  
counter/timer functional blocks  
    input circuit 34  
    T8 transmit mode 34  
counter\_INT\_mask 33  
crt3 T8/T16 control register  
    register 33



CTR(D)01h T8 and T16 common functions 29  
CTR1 (0D)01 28  
CTR3 T8/T16 control CTR3(0D)03h 33

## D

DC characteristics 8  
demodulation mode  
    count capture flowchart 38  
    flowchart 39  
    T16 41  
    T8 37  
description  
    functional 19  
    general 2  
    pin 5

## E

EPROM  
    selectable options 59  
expanded register file 21  
expanded register file architecture 22  
expanded register file control registers 65  
    flag 74  
    interrupt mask register 73  
    interrupt priority register 72  
    interrupt request register 73  
    port 0 and 1 mode register 71  
    port 2 configuration register 69  
    port 3 mode register 70  
    port configuration register 69  
    register pointer 74  
    stack pointer high register 75  
    stack pointer low register 75  
    stop-mode recovery register 67  
    stop-mode recovery register 2 68  
    T16 control register 63  
    T8 and T16 common control functions register 62  
    TC8 control register 60  
    watch-dog timer register 69

## F

features  
    standby modes 1  
    ZLR16300 1  
functional description  
    counter/timer functional blocks 34  
    CTR0(0D)00h register 27  
    CTR1(0D)01h register 29  
    CTR2(0D)02h register 31  
    expanded register file 21  
    expanded register file architecture 22  
    HI16(0D)09h register 26  
    HI8(0D)0Bh register 26  
    L08(0D)0Ah register 26  
    L016(0D)08h register 26  
    program memory map 20  
    RAM 19  
    register description 59  
    register file 24  
    register pointer 23  
    register pointer detail 25  
    stack 25  
    TC16H(0D)07h register 26  
    TC16L(0D)06h register 27  
    TC8H(0D)05h register 27  
    TC8L(0D)04h register 27  
    TC8L(D)04h register 27

## G

glitch filter circuitry 34

## H

halt instruction, counter/timer 48

## I

input circuit 34  
interrupt block diagram, counter/timer 45  
interrupt types, sources and vectors 46



## L

low-voltage detection register 59

## M

memory, program 19

modulo-N mode

T16\_OUT 41

T8\_OUT 37

## O

oscillator configuration 47

output circuit, counter/timer 43

## P

P34\_out 28

P35\_out 33

P36\_out/demodulator input 30

package information

20-pin DIP package diagram 76

20-pin SSOP package diagram 77

28-pin DIP package diagram 79

28-pin SOIC package diagram 78

28-pin SSOP package diagram 80

part number format 82

pin configuration

20-pin DIP/SOIC/SSOP 5

28-pin DIP/SOIC/SSOP 6

pin functions

port 0 (P07 - P00) 13

port 0 configuration 14

port 2 (P27 - P20) 14

port 2 (P37 - P30) 15

port 2 configuration 15

port 3 configuration 16

port 3 counter/timer configuration 18

XTAL1 (time-based input) 12

XTAL2 (time-based output) 12

ping-pong mode 42

port 0

configuration 14

pin function 13

port 2

configuration 15

pin function 14

port 3

configuration 16

counter/timer configuration 18

port 3 pin function 15

port configuration register 49

power connections 2

power supply 5

program memory 19

map 20

## R

ratings, absolute maximum 6

register 55

CTR0(0D)00h 27

CTR1 (0D) 01 28

CTR1(0D)01h 29

CTR2(0D)02h 31

flag 74

HI16(0D)09h 26

HI8(0D)0Bh 26

interrupt priority 72

interrupt request 73

interruptmask 73

L016(0D)08h 26

L08(0D)0Ah 26

LVD(D)0Ch 59

pointer 74

port 0 and 1 71

port 2 configuration 69

port 3 mode 70

port configuration 49, 69

stack pointer high 75

stack pointer low 75

stop mode recovery 51

stop mode recovery 2 55

stop-mode recovery 67

stop-mode recovery 2 68

T16 control 63

T8 and T16 common control functions 62



- TC16H(0D)07h 26
- TC16L(0D)06h 27
- TC8 control 60
- TC8H(0D)05h 27
- TC8L(0D)04h 27
- TC8L(D)04h 27
- voltage detection 65
- watch-dog timer 69
- register description
  - counter/timer2 LS-Byte hold 27
  - counter/timer2 MS-Byte hold 26
  - counter/timer8 control 27
  - counter/timer8 High hold 27
  - counter/timer8 Low hold 27
  - CTR2 counter/timer 16 control 31
  - T16\_capture\_LO 26
  - T8 and T16 common functions 29
  - T8\_Capture\_HI 26
  - T8\_capture\_LO 26
- register file 24
  - expanded 21
- register pointer 23
  - detail 25
- resets and WDT 58

## S

- SCLK circuit 52
- single/modulo-N 28, 32
- single-pass mode
  - T16\_OUT 41
  - T8\_OUT 37
- stack 25
- standard test conditions 7
- standby modes 1
- stop instruction, counter/timer 48
- stop mode recovery
  - 2 register 55
  - source 53
- stop mode recovery 2 55
- stop mode recovery register 51

## T

- T 16 clock 33
- T16 enable 32
- T16 initial out/falling edge 31
- T16 transmit mode 40
- T16\_capture\_HI 26
- T8 and T16 common functions 28
- t8 clock 28
- T8 enable 28
- T8 initial out/rising edge 31
- T8 transmit mode 34
- T8/T16\_logic/edge\_detect 31
- T8\_Capture\_HI 26
- test conditions, standard 7
- test load diagram 7
- time\_out 33
- timeout 28
- timers
  - counter/timer2 LS-byte hold 27
  - counter/timer2 MS-byte hold 26
  - counter/timer8 high hold 27
  - counter/timer8 low hold 27
  - CTR0 counter/timer8 control 27
  - T16\_Capture\_HI 26
  - T16\_Capture\_LO 26
  - T8\_Capture\_HI 26
  - T8\_Capture\_LO 26
- timing diagram, AC 10
- transmit mode flowchart 35
- transmit\_submode/glitch filter 31

## V

- VCC 5
- voltage
  - brown-out/standby 59
  - detection and flags 60
  - voltage detection register 65

## W

- watch-dog timer
  - mode registerwatch-dog timer mode regis-



ter 56  
time select 57

## **X**

XTAL1 5  
XTAL1 pin function 12  
XTAL2 5  
XTAL2 pin function 12

## **Z**

ZLR16300 family members 1